

**Making of Roof Flashing – Course: Timberwork techniques. Trainees'
handbook of lessons**

Table of Contents

<u>Making of Roof Flashing – Course: Timberwork techniques. Trainees' handbook of lessons</u>	1
1. <u>Purpose of Roof Flashings</u>	1
2. <u>Types of Roof Flashings</u>	1
3. <u>The Eaves Flashing of Couple Roofs</u>	6
4. <u>The Eaves Flashing of Purlin Roofs</u>	10
5. <u>Structural Design of Purlin Roof Eaves Flashings</u>	11
6. <u>The Suspended Gutter</u>	16

Making of Roof Flashing – Course: Timberwork techniques. Trainees' handbook of lessons

**Institut für berufliche Entwicklung e.V.
Berlin**

Original title:
“Herstellen von Dachüberständen”

Author: Rolf Becher

First Edition © IBE

Institut für berufliche Entwicklung e.V.
Parkstraße 21–23
13187 Berlin

Order No.: 93–35–3603/2

1. Purpose of Roof Flashings

Roof flashings are necessary to protect the top border of the outside walls of buildings from penetrating rain water. In the course of time, penetrated rain water would destroy the upper layers of the containing walls of buildings and render the building unusable.

If the upper layers of containing walls of buildings are soaked with moisture, this may result in efflorescence and dry rot in the brickwork.

Removal of such damage to the building is very expensive in terms of time and money. In addition to the beginning destruction of the brickwork or framework wall, moisture would penetrate into room walls. Room walls thoroughly moistened would annoy the user of the room by bad smells and damage furniture and textiles in the room. Moreover, permanent stay in such rooms with moistened walls is detrimental to the health of the room user.

But roof flashings are also important for the architectural design of the roof structure or required to make the form of the roof match the surrounding roofs.

2. Types of Roof Flashings

There are three types of roof flashings which can already be provided for in the distance of the roof structure or be made in the course of maintenance work of the building.

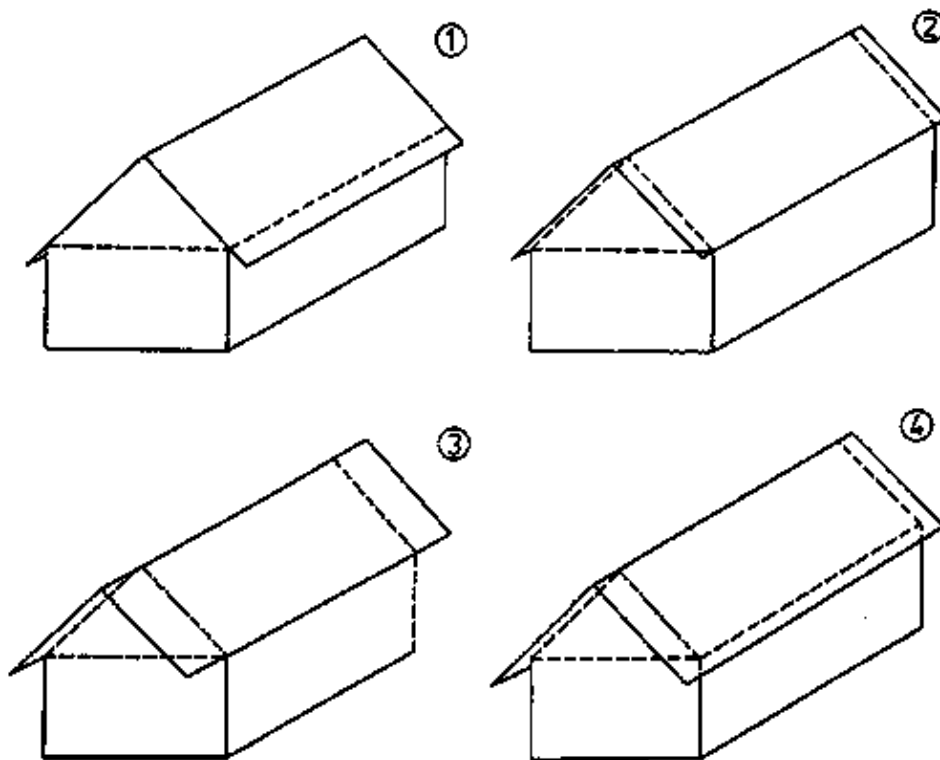

Figure 1

Types of roof flashings

- (1) *eaves flashing*,
- (2) *verge flashing*,
- (3) *extended verge flashing*,
- (4) *extended verge flashing and eaves flashing*

The verge flashing

Verge flashing is the projection of the roof boards or battens of a building the roof faces of which are bordered by verge lines.

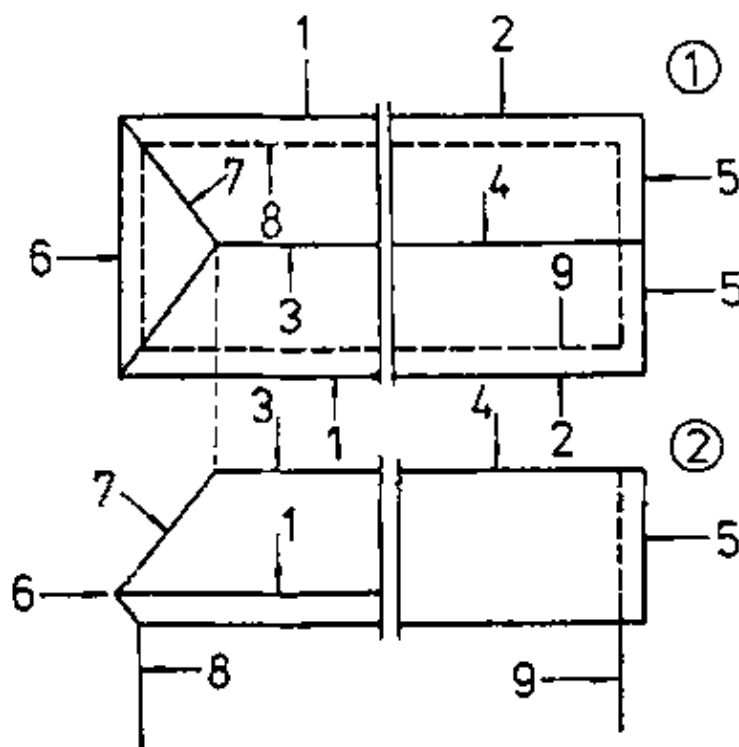

Figure 2

Bordering of roof faces

(1) top view, (2) front view

1 eaves line of main roof (hip roof), 2 eaves line of gable roof, 3 ridge line of hip roof, 4 ridge line of gable roof, 5 verge line of gable roof, 6 eaves line of hip (hip roof), 7 arris line of hip roof, 8 outside edge of containing wall (hip roof), 9 outside edge of containing wall (gable roof)

The projection of the roof boards or battens at the gable of a building should be within 150 mm to 200 mm. If roof boards are used for fixing the roofing (roofing felt, roofing slate, shingles), they are to be stabilized at the verge flashing.

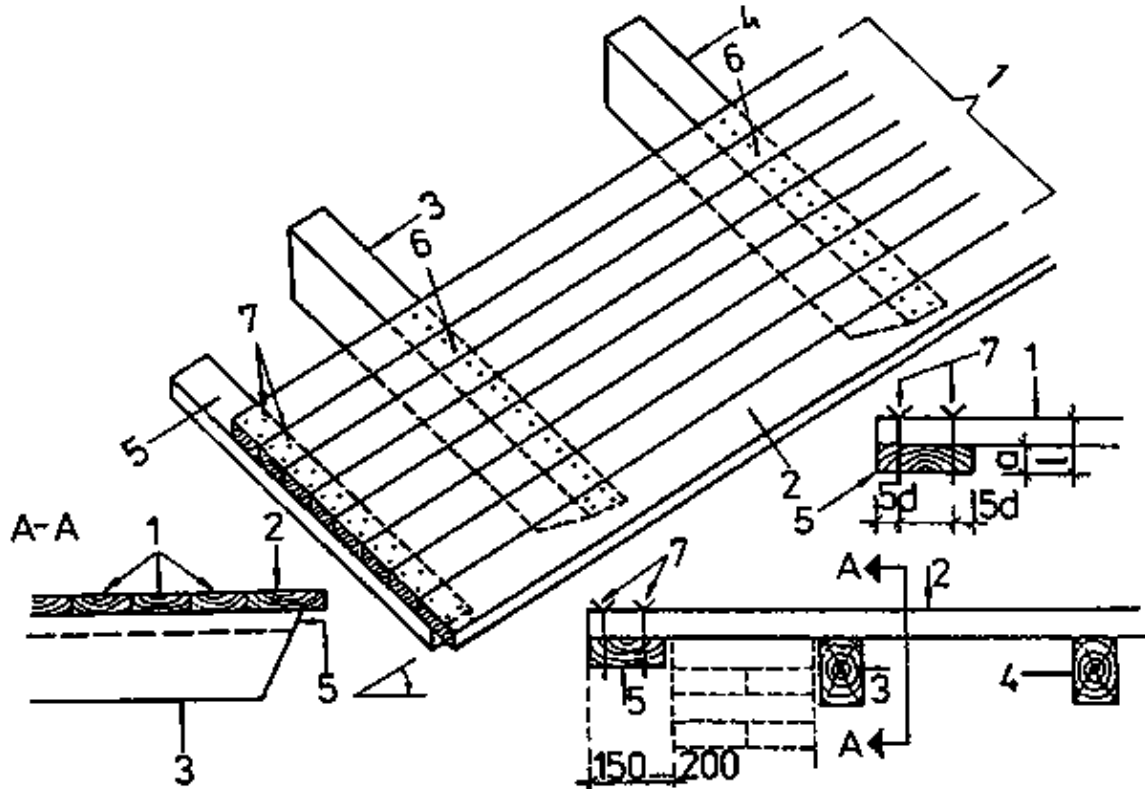

Figure 3

Verge flashing design

1 roof boards, 2 eaves board, 3 verge rafter (roof rafter at the gable), 4 intermediate rafter, 5 verge board, 6 nailing on roof rafter, 7 nailing of verge board a) projecting length of nail, d) diameter of nail shank, l nail length

For stabilization, a board of adequate width (= 120 mm) is nailed under the projecting roof boards. The stabilizing board must be flush at the verge. It is fixed with nails which penetrate the roof boards and the verge board and are at least 5 mm longer. The nails are driven in from above (roof boards) and staggered at an adequate distance from the edge of the verge board.

The nail end penetrating from the verge board is to be clinched with the grain.

Why must the nail be driven in from above?

Why is the penetrating end of the nail clinched with the grain?

Why are the nails driven in staggered arrangement at an adequate distance from the edge of the verge board?

If the verge flashing is not stabilized, the roofing may tear and rain water can penetrate the roofing.

In case of slated roofs the slates may loosen and leave gaps in the roofing.

What will happen when gaps are in the roofing?

To prevent the wind from driving rain water over the verge flashing, which would leave traces of the dirty dripping water on the surface of the gable, a wind plate is fixed along the verge.

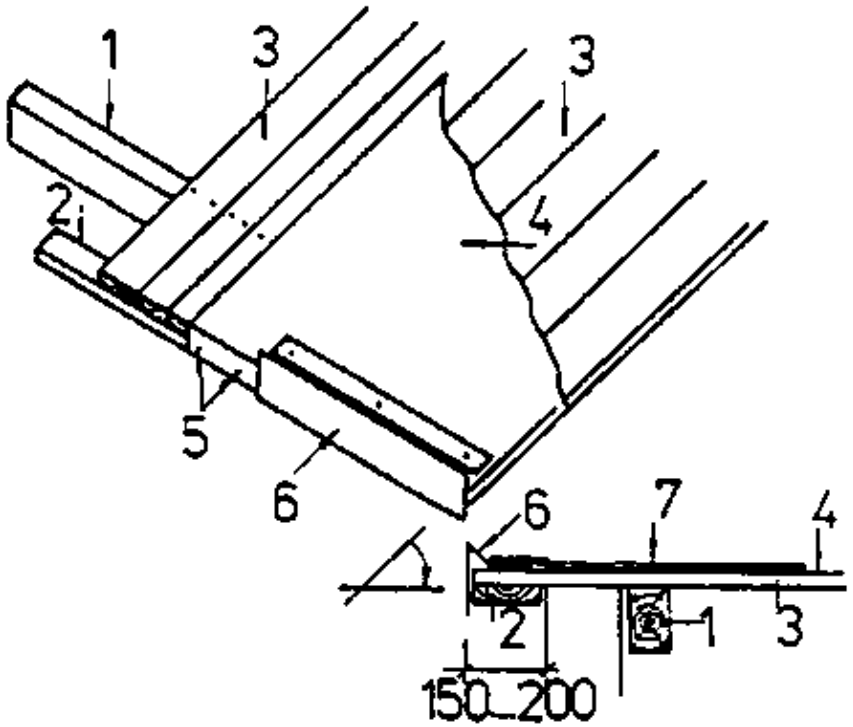

Figure 4

Wind plate at verge flashing

1 verge rafter, 2 verge board, 3 roof boards, 4 roofing felt (first layer), 5 roofing nail, 6 wind plate, 7 roofing felt (second layer, pasted)

The wind plate is nailed on the first layer of roofing felt. It must be made of non-rusting material! If the roofing consists of tiles, the roof battens must also be stabilized at the verge flashing. To prevent the wind from lifting the roofing tiles, the width of the verge board and the projection of the roof battens should be of equal size!

The extended verge flashing

An extended verge flashing can be relatively easy provided for when a new roof structure is to be built.

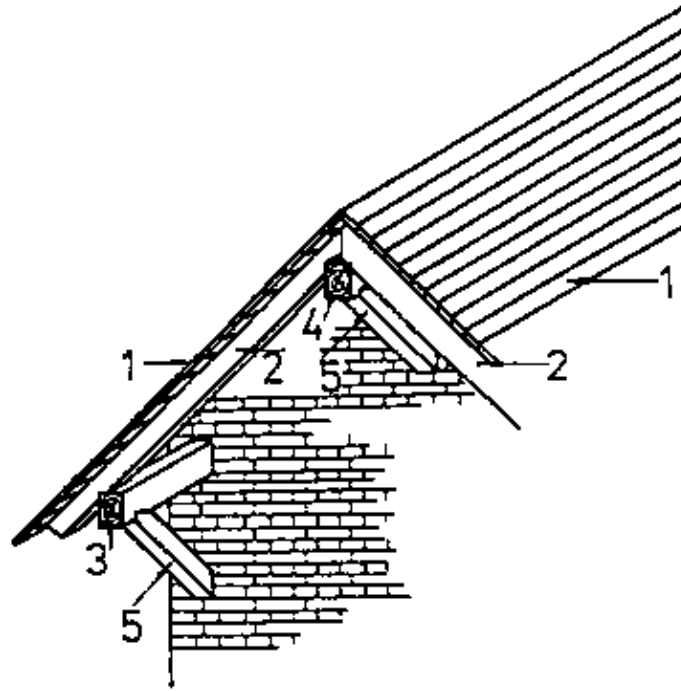

Figure 5

Extended verge flashing with eaves flashing

1 roof boards (roof boarding), 2 verge rafter, 3 inferior purlin, 4 ridge purlin, 5 brace (supporting the cantilever)

It can only be designed with a purlin roof with simple or multiple standing roof truss.

The verge rafters are supported by the purlins which are designed as cantilever and have to be calculated statically. An extended verge flashing to be made in the course of maintenance or reconstruction work would involve a lot of manual work and material.

The eaves flashing

Each roof face must have an eaves flashing.

It can be designed with both the (rafter) couple roof and the purlin roof.

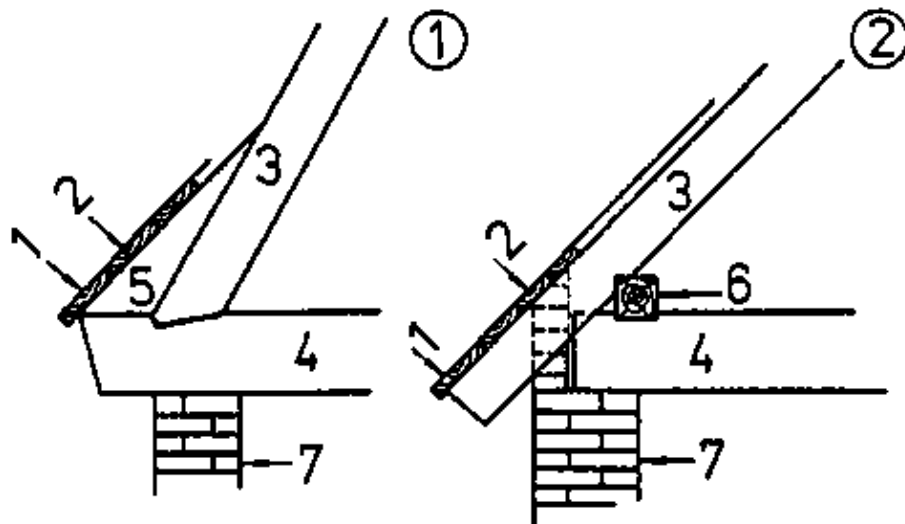

Figure 6

(1) eaves flashing of couple roof (rafter roof)

(2) eaves flashing of purlin roof

1 eaves board, 2 roof boards, 3 roof rafter, 4 wooden beam, 5 chantlate, 6 inferior purlin, 7 beam bearing

The structural design is different. The eaves flashing, if to be designed with new roof structures, can be made with couple or purlin roofs in the course of joining or, if to be designed in the course of maintenance work, with existing purlin roofs. The length of the eaves flashing is limited because of lifting wind forces to be expected. On the other hand, it must also match the architectural design of the roof structure of the building and the roof design of surrounding buildings as well.

A low facade with long eaves flashing, for example, would make a building look compressed and plain.

Also, a long eaves flashing would affect the natural incidence of light through the windows of the rooms and have an unpleasant effect on the atmosphere of the rooms.

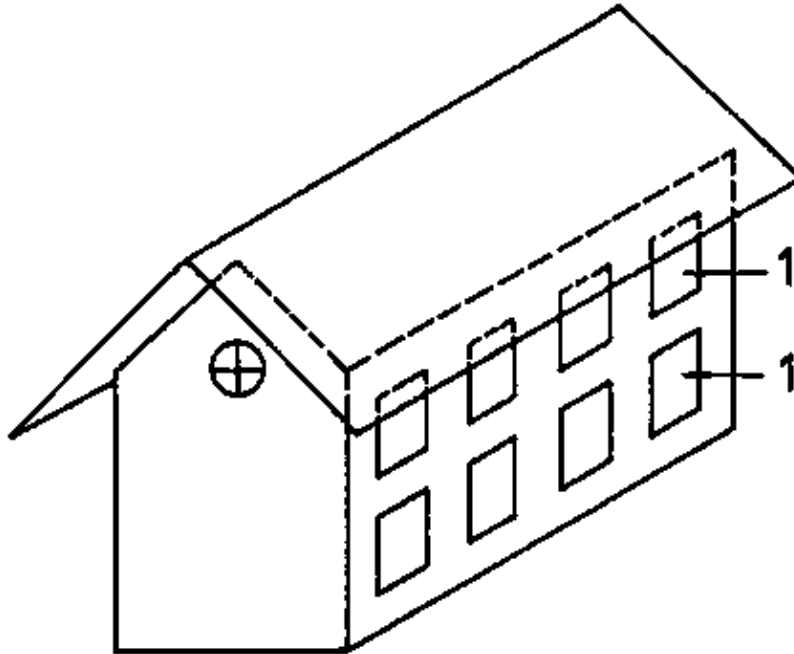

Figure 7

Long eaves flashing
1 windows

3. The Eaves Flashing of Couple Roofs

An eaves flashing of a couple roof can only be made with a roof structure to be newly built which is supported by a wooden beam ceiling.

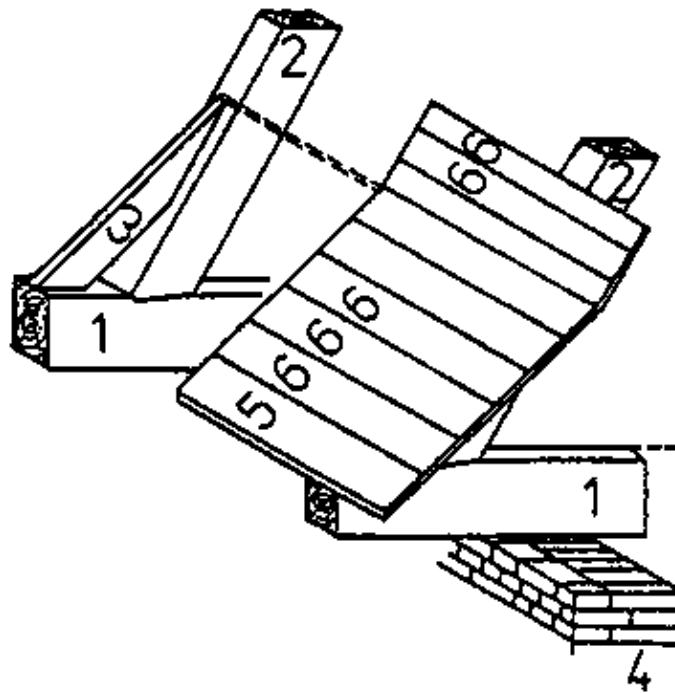

Figure 8

1 wooden beam, 2 roof rafter, 3 chantlate, 4 beam bearing, 5 eaves board, 6 roof boards

The wooden beams projecting over the outside walls can be designed with a profiled beam head or be faced by a roof base facing.

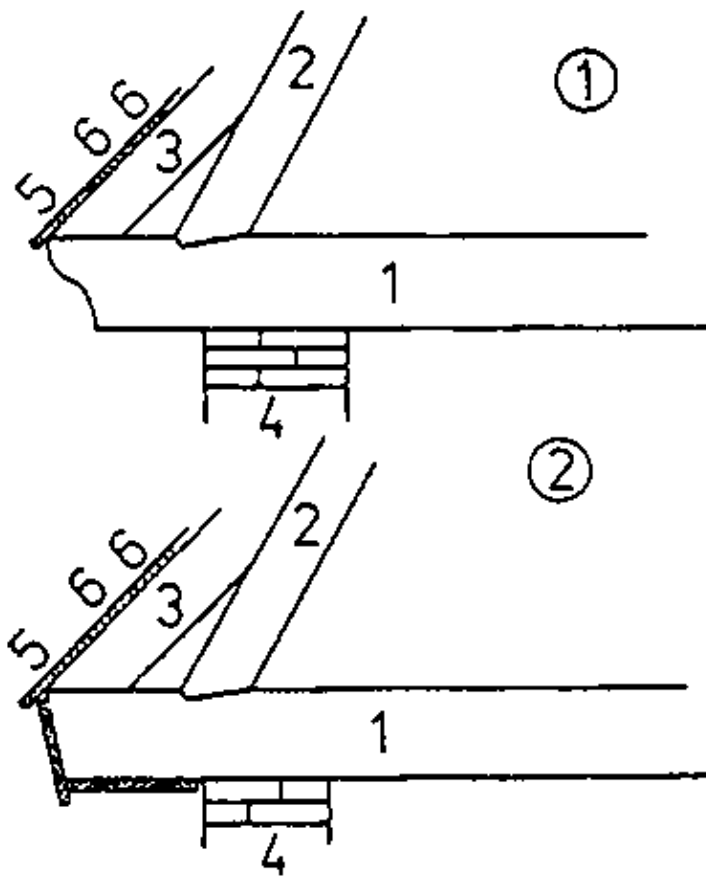

Figure 9

(1) profiled beam head, (2) roof base facing

1 wooden beam, 2 roof rafter, 3 chantlate, 4 beam bearing, 5 eaves board, 6 roof boards

The profile of the beam head is manually sawn out with a frame saw with fret saw blade or with a hand chain saw. If a hand chain saw is used, the wooden beam must be safely supported by the saw horse so that it cannot tilt when the saw is applied.

Why must the wooden beam tilt not or cant when the saw is applied?

If the beam heads are faced by a roof base facing, it is recommended to let the beam project by 300 mm and to provide the cross-grain end with a 50 mm back-off.

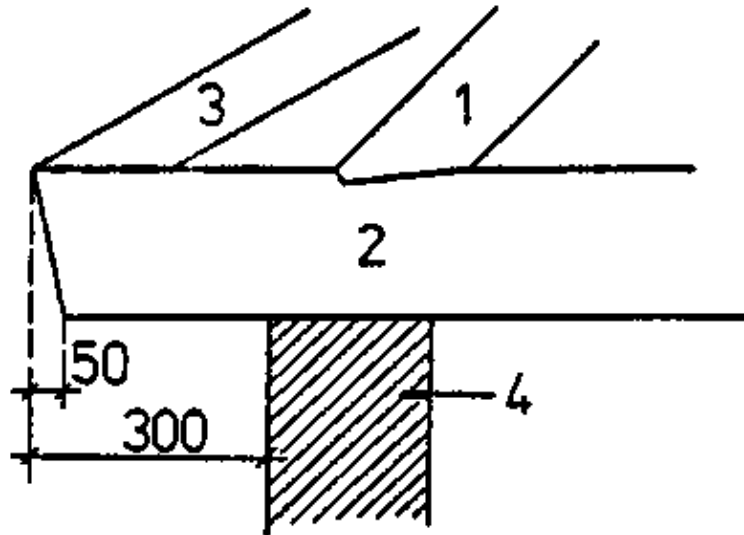

Figure 10

1 roof rafter, 2 wooden beam, 3 chantlate, 4 beam bearing

By backing off the cross-grain ends, the front face of the roof base facing can be inclined so as to make the roof base facing look more elegant.

Tongued and grooved boards of 130 mm width should be used for the roof base facing.

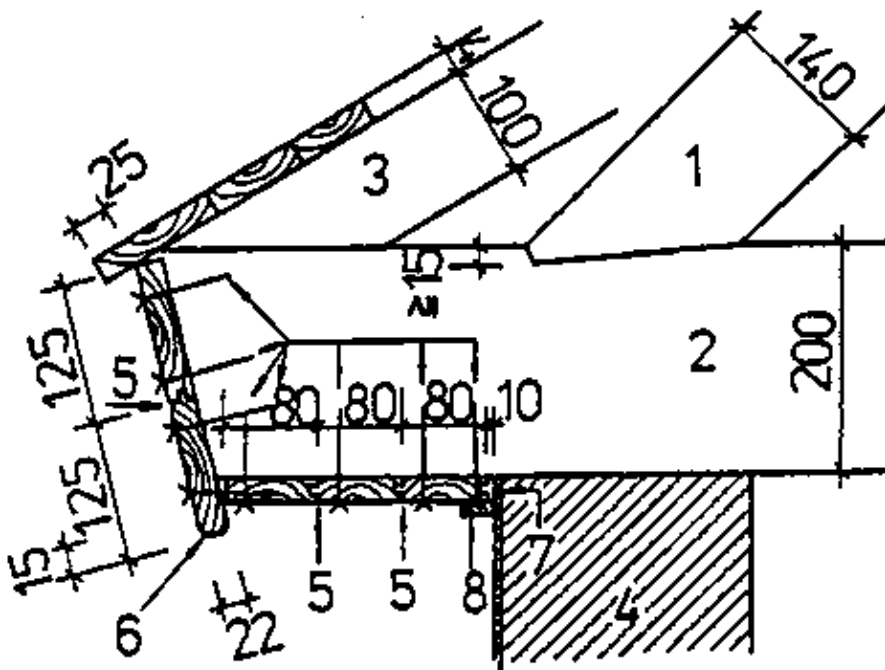

Figure 11

Structural design of roof base facing

1 roof rafter, 2 wooden beam, 3 chantlate, 4 beam bearing, 5 chamfer at the longitudinal sides of the boards, 6 chamfer at both sides of the narrow face of the board, 7 outside edge of outside wall, 8 plasterwork strip

Why should no wider boards be used for the roof base facing?

The roof base facing boards should not be forced together to allow the wood to contract and expand.

The longitudinal sides of the joined boards should be slightly chamfered to make the joint between the facing boards look better when the wood contracts or expands. The tongues of the first bottom board and face board are to be cut off to achieve a good contact with the eaves board and the face board (see. Figure 11).

The lower face board should extend 15 mm below the bottom board. The groove of this board is to be cut off and the narrow face of the board to be provided with a chamfer at both sides. The nails used for fixing the roof base facing boards are to be driven in.

An air gap of about 10 mm is to be left between the outside plasterwork and the bottom board of the roof base facing.

This air gap is covered by a plasterwork strip which is adapted to the existing unevenness of the plaster surface (see Fig. 11).

Why shall the nails be driven in?

If the couple roof is supported by a solid ceiling, the eaves flashing is achieved by a cornice connected to the solid ceiling.

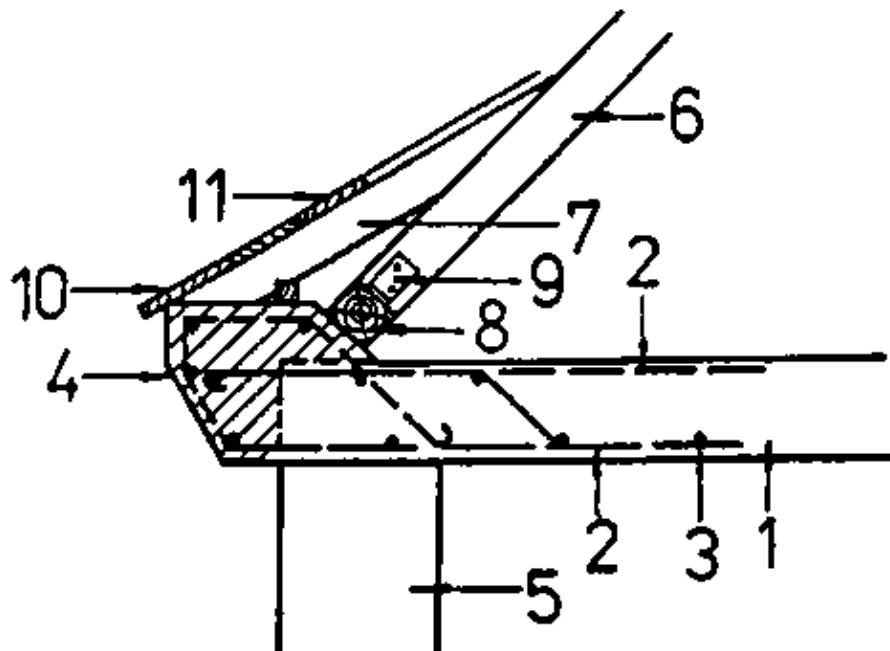

Figure 12

Cornice at solid ceiling

1 solid ceiling, 2 main reinforcement, 3 cross reinforcement, 4 cornice, 5 ceiling bearing, 6 roof rafter, 7 chantlate, 8 sleeper, 9 steel angle, 10 eaves board, 11 roof boards

4. The Eaves Flashing of Purlin Roofs

The eaves flashing of a purlin roof can be achieved by an attached cornice or by displacing the rafter foot beyond the containing wall of the building.

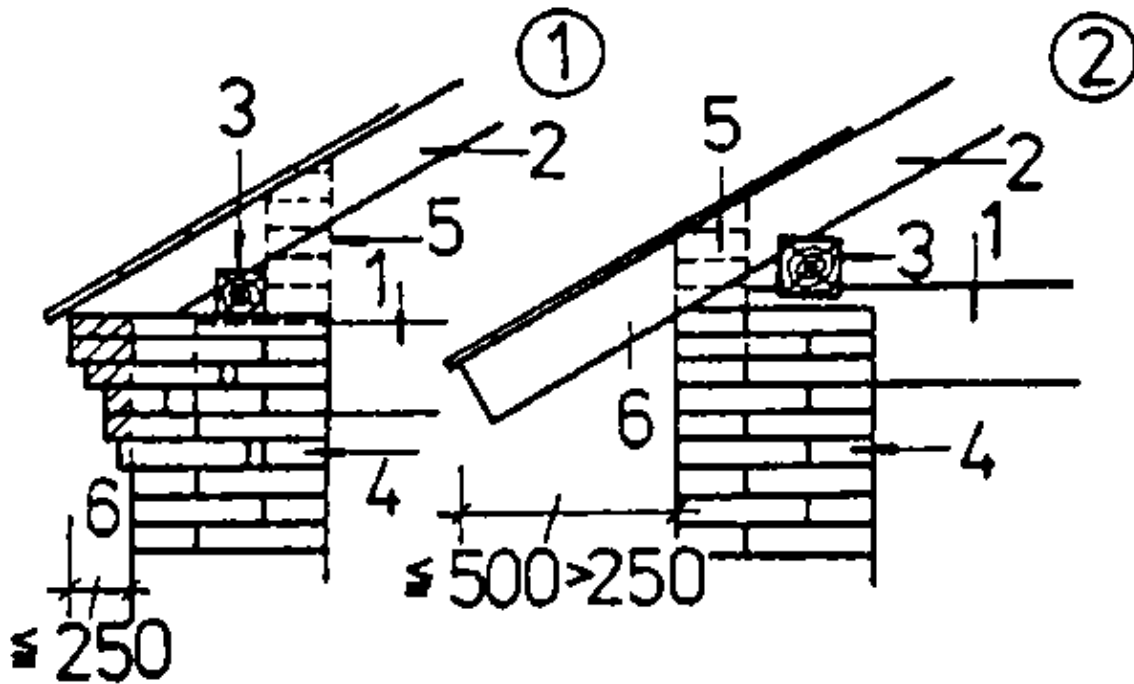

Figure 13

Eaves flashing

(1) by cornice, (2) by displacement of the rafter foot

1 wooden beam, 2 roof rafter, 3 inferior purlin, 4 containing wall, 5 extended brickwork, 6 eaves flashing

It can be designed with roof structures to be built or already existing. However, it is considerably more expensive and complicated to design eaves flashings with roof structures already existing. It is, therefore, recommended to design it only if necessary for maintaining existing buildings. The size of the eaves flashing is to be adapted to the roof form. It should not exceed 500 mm.

Why should the eaves flashing not exceed 500 mm?

The rafter foot can be rough, planed on three sides, profiled or covered by a roof base facing.

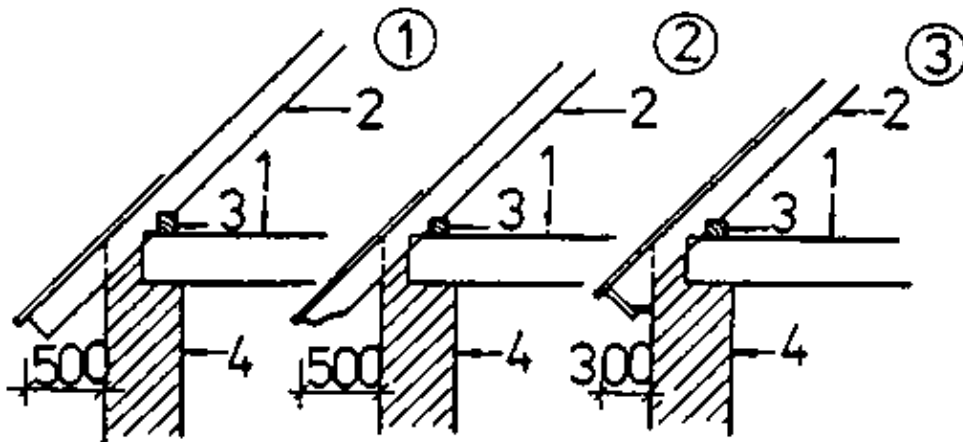

Figure 14

(1) non-profiled eaves flashing, (2) profiled eaves flashing, (3) eaves flashing with roof base facing
 1 wooden beam, 2 roof rafter, 3 inferior purlin, 4 containing wall

If the rafter feet are faced by a roof base facing, it is recommended that the horizontal distance of the flashing does not exceed 300 mm (see Fig. 14 (3)).

The bottom boards of the roof base facing should be arranged horizontally because this will make the base facing look better.

5. Structural Design of Purlin Roof Eaves Flashings

When an eaves flashing of a purlin roof is to be designed, there is a difference in designing it for a roof structure to be built or for a roof structure already existing and to be provided with a flashing in the course of maintenance of the building.

Eaves flashing of a roof structure to be built

In this case it is relatively easy to provide an eaves flashing because rafters can be used which are extended by the size of the eaves flashing. The size of the eaves flashing, however, is to be measured from the outside face of the containing wall!

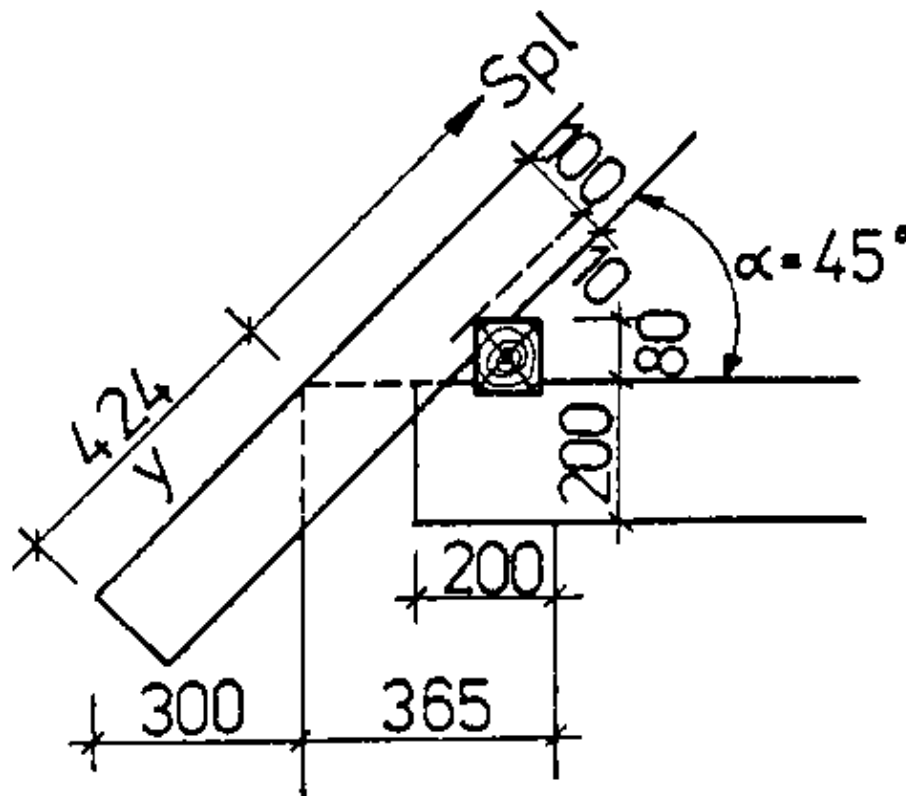

Figure 15

Laid-out eaves flashing
 Spl roof rafter length, y roof rafter extension

The difference (y) can be taken from a detail drawing in the scale 1:1 or be laid out in the scale 1:1. It is also possible to calculate the eaves flashing.

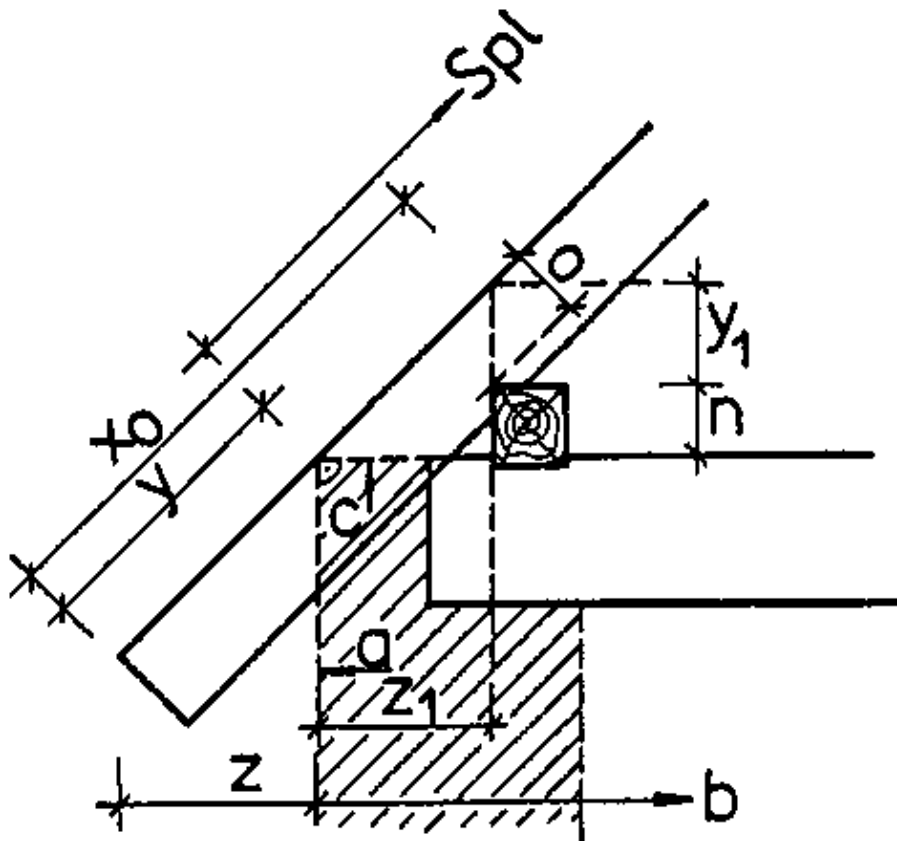

Figure 16

When the surface of the attic beam and the front face of the outside wall are square to each other and have a joint point of intersection with the surface of the roof rafter, the calculation is based on the following:

$$y = \frac{Spl_R \cdot z}{b}$$

$$x_0 = \frac{Spl_R(z + z_1)}{b}$$

y – extension of roof rafter length

z – horizontal distance of eaves flashing

b – half the width of building

z₁ – secondary size (auxiliary size)

x₀ – joining size (length from inferior purlin line to roof rafter foot)

Spl_R – roof rafter length from calculation

a – surface of attic beam

c – front face of outside wall

$$Spl = Spl_R + y$$

$$Spl_R = b^2 + h^2$$

Spl – real rafter length

h – roof height

$$z_1 = \frac{b(y_1 + n)}{h}$$

y_1 – perpendicular attachment timber
 n – height of inferior purlin above surface of attic beam

$$y = \frac{Spl_R \cdot o}{b}$$

o – square attachment timber

Eaves flashing for an existing roof structure

This structural design is mainly used in connexion with maintenance of existing buildings. For example, if a dilapidated cornice is broken involving the danger of falling down, proofing of the building can be achieved again by an extending rafter foot.

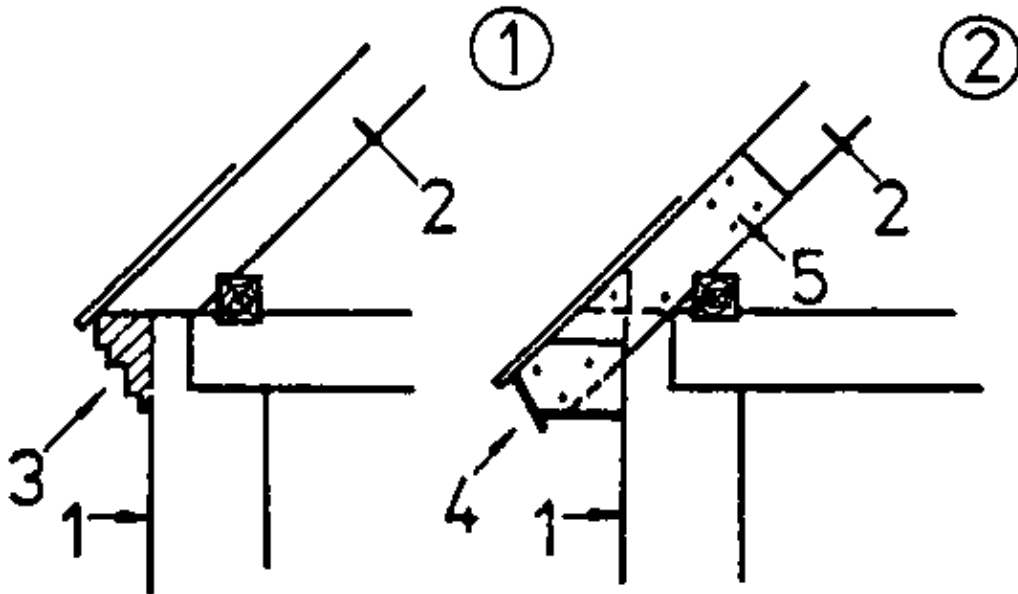

Figure 17

(1) dilapidated cornice, (2) new eaves flashing
 1 containing wall, 2 roof rafter, 3 cornice, 4 roof base facing, 5 nailed cover strap

Proofing of the building can also be achieved by displacement of the rafter foot.

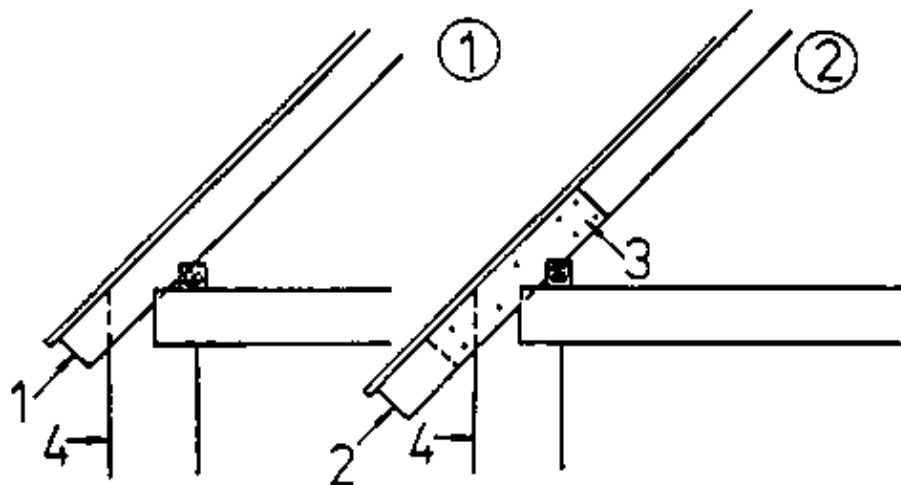

Figure 18

Re-proofing of buildings

(1) former eaves flashing, (2) new eaves flashing
 1 rafter foot, 2 displaced rafter foot, 3 nailed cover strap, 4 containing wall

In both cases displacement of the rafter foot can be implemented by nailing cover straps laterally onto the roof rafter. It is recommended to cover the eaves flashing by a roof base facing.

Why is a roof base facing to be recommended?

The cover straps to be nailed on must be sufficiently long and be birdsmouthed to the inferior purlin.

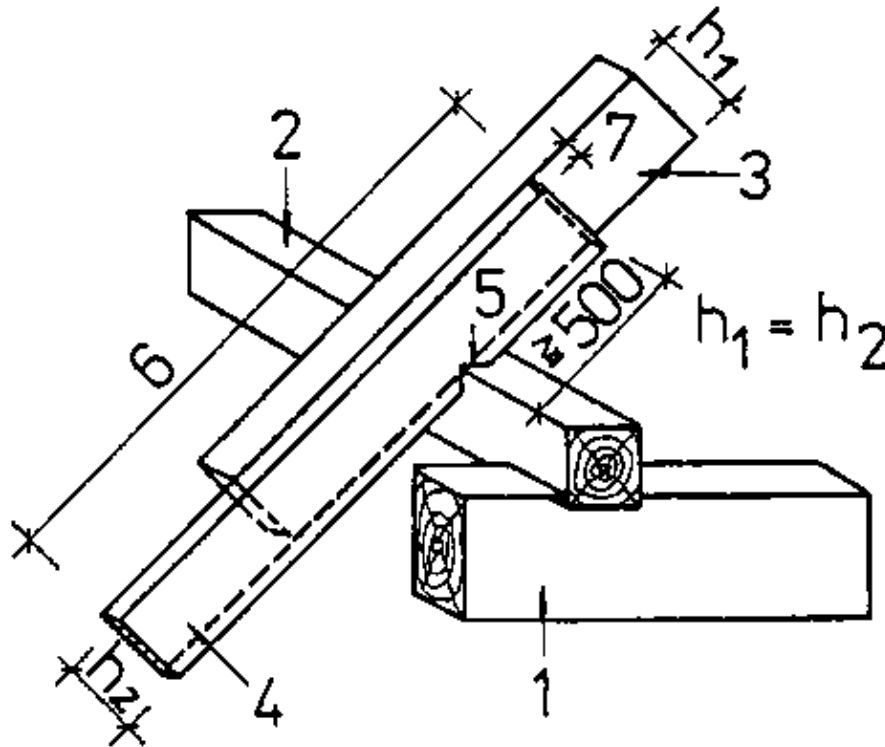

Figure 19

1 wooden beam, 2 inferior purlin, 3 roof rafter, 4 cover strap, 5 birdsmouth, 6 length of cover strap, 7 thickness of cover strap,
 h height of roof

The width of the cover strap must be equal to the roof rafter height and the thickness should be 40 mm to 50 mm. The length of the nails to be used for nailing the cover strap to the roof rafter should be equal to or greater than the thickness of the cover strap. Keeping an adequate distance of the nails, groups of at least four nails each should be driven-in above and below the inferior purlin.

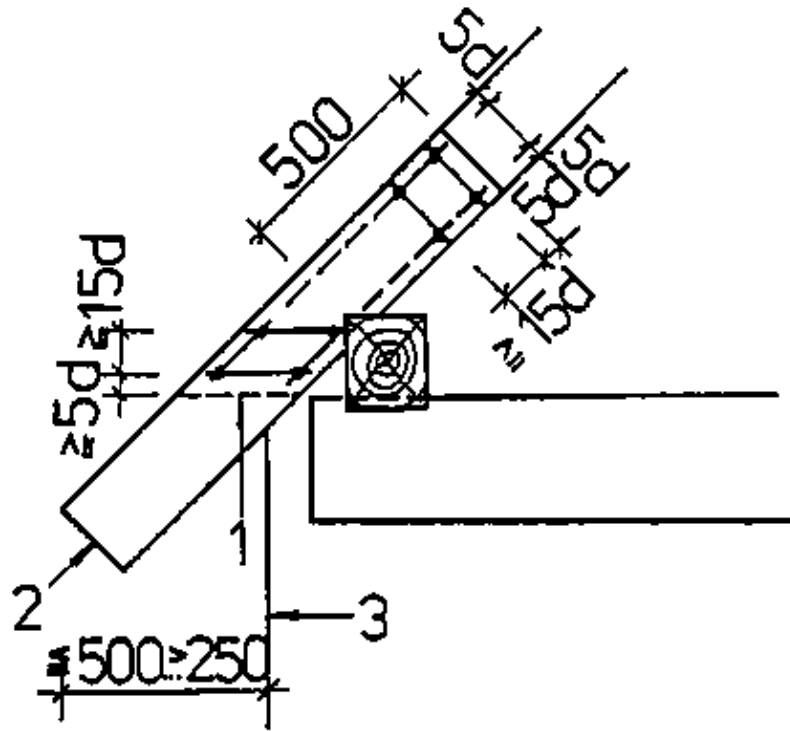

Figure 20

Arrangement of nail groups

1 former rafter foot, 2 extended rafter foot, 3 front face of outside wall
d diameter of nail shank

In order to be able to fix the boards for the roof base facing, cleats complying with the profile of the roof base facing are to be nailed to the cover straps.

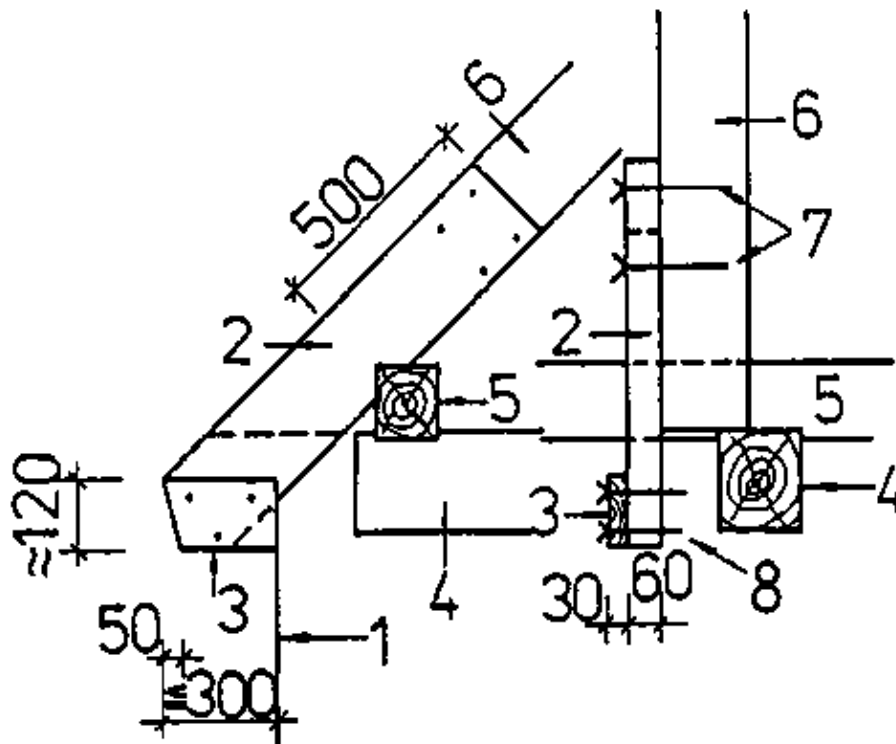

Figure 21

1 front face of outside wall, 2 cover strap, 3 cleat, 4 wooden beam, 5 inferior purlin, 6 roof rafter, 7 nails for cover straps, 8 nails for cleats

For this purpose, nails are to be used which are long enough to penetrate the two timbers and can be clinched with the grain of the wood.

Why must the nails be clinched?

The two gable sides of the roof base facing are to be closed. For this purpose, pieces of boards complying with the profile of the roof base facing are to be inserted and nailed.

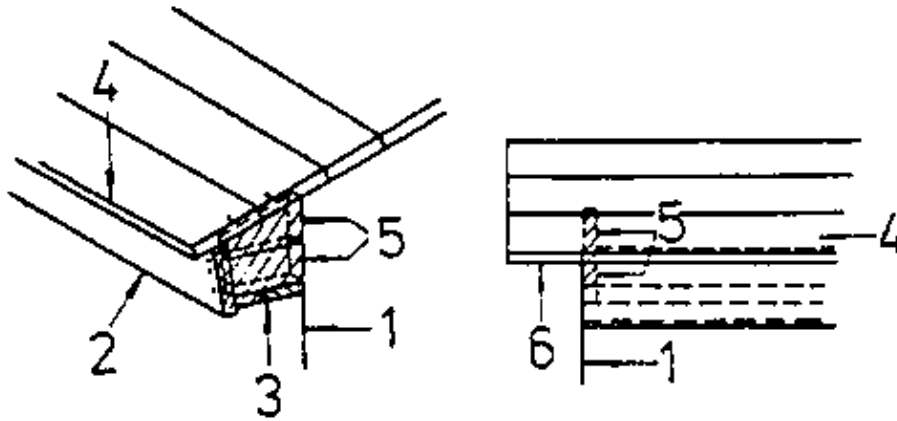

Figure 22

Closing of the roof base facing

1 front face of outside wall. 2 face of roof base facing, 3 bottom of roof base facing, 4 eaves board, 5 inserted board pieces, 6 verge flashing

Why must the two gable sides be closed?

6. The Suspended Gutter

To prevent the rain water from flowing down the eaves flashing, a gutter is suspended from the eaves.

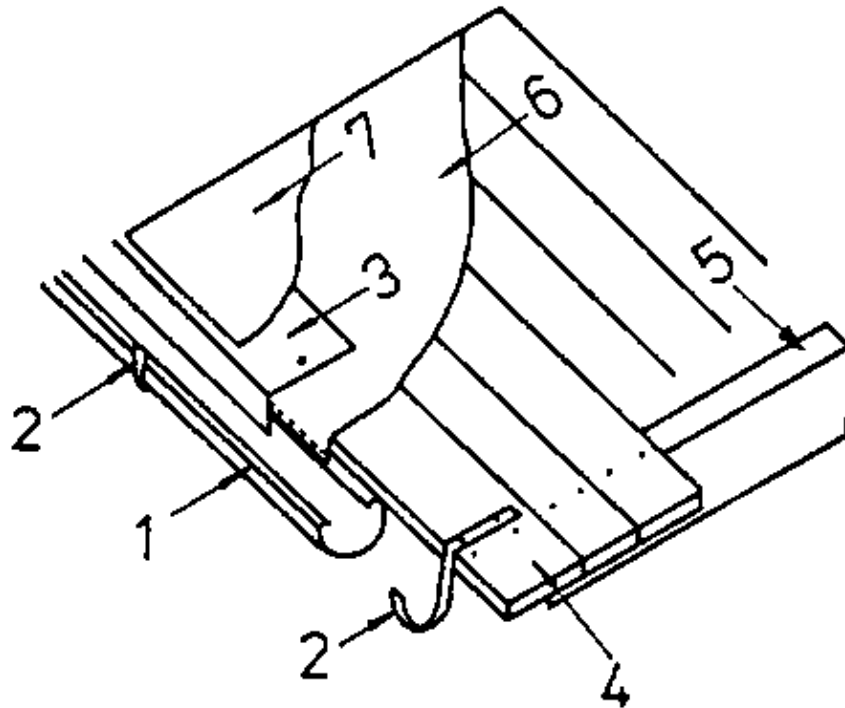

Figure 23

Suspended gutter

1 gutter, 2 gutter bracket, 3 cover plate, 4 eaves board, 5 roof rafter, 6 first layer of roofing felt (nailed), 7 second layer of roofing felt (pasted)

The gutter brackets to hold the gutter are sunk in into the eaves board and screwed to it.

The covering plate is nailed to the first layer of roofing felt. It extends into the gutter to prevent rain water from running down between the cover plate and gutter.

The gutter brackets, the gutter and the cover plate must be made of non-rusting material.

The second layer of roofing felt is not nailed but pasted with bitumen on the first layer. It ends on the covering plate.

