

Sawing – Course: Manual woodworking techniques. Instruction examples for practical vocational training

Table of Contents

<u>Sawing – Course: Manual woodworking techniques. Instruction examples for practical vocational training</u>	1
<u>Preliminary Remarks</u>	1
<u>Instruction Example 2.1. Cutting to Length of a Board</u>	1
<u>Instruction Example 2.2. Cutting to Length of Strips (Frame Strips)</u>	3
<u>Instruction Example 2.3. Overlapping Joint</u>	5
<u>Instruction Example 2.4. Cutting of Plies</u>	7
<u>Instruction Example 2.5. Curves</u>	9

Sawing – Course: Manual woodworking techniques. Instruction examples for practical vocational training

**Institut für berufliche Entwicklung e.V.
Berlin**

Original title:
Lehrbeispiele für die berufspraktische Ausbildung
“Sägen”

Author: Fritz Dienemann

First edition © IBE

Institut für berufliche Entwicklung e.V.
Parkstraße 23
13187 Berlin

Order No.: 93–33–3302/2

Preliminary Remarks

The present booklet includes five selected instruction examples to practise the sawing techniques like sawing across the grain, sawing with the grain, sawing of curves, sawing of panels and manufacturing of connecting elements. The applied material is sawn wood and plies.

The necessary precision reaches from cutting to length with working allowances for further working steps to sawing to final size with high precision.

To help with the preparation and realization of the work, the necessary materials, tools and auxiliary accessories are indicated for each instruction example. Necessary basic knowledge of scribing is also mentioned and should be repeated before starting with sawing.

The sequence of operations specified for each instruction example includes the steps necessary to manufacture the relevant workpiece. This sequence is to be followed if a good quality is to be achieved.

To each instruction example a working drawing is added showing the required shapes and dimensions of the workpieces.

The results of the instruction examples are single parts which, after further working steps like planing, can be used to manufacture fillings for different purposes.

Instruction Example 2.1. Cutting to Length of a Board

A raw board shall be cut to length by separating cuts across the grain.

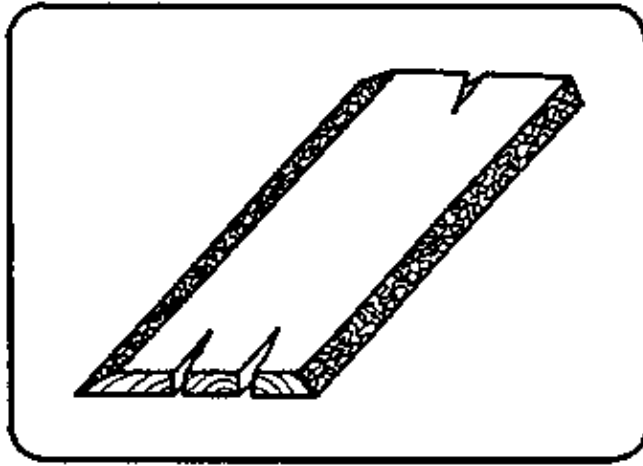

Material

A raw board of hard wood or soft wood

Thickness: 30 mm

Width: at least 150 mm

Length: at least 1250 mm

Tools, measuring and testing means

Folding rule, pencil, try square, frame saw (cross-cut saw), cutting angle = 120°

Auxiliary accessories

Saw horses, bench (carpenter's bench)

Necessary previous knowledge

Measuring, scribing, reading of drawings

Explanations to the working drawing

1 – required length

Sequence of operations	Comments
1. Prepare the working place.	Check for completeness.
2. Place the material on the saw horses or clamp the material in the carpenter's bench.	The number of the saw horses depends on the length of the board.
3. Scribe the board according to the drawing, mark the cutting line nearly square to the grain with a pencil.	Ask for the sizes of the required length; consider the length allowance; check the scribed line with the try square.
4. Select and check the fram saw.	Cuts across the grain require push-and-pull cutting, check the sharpness of the saw.

5. Cut off the board's end. Guide the sawing tool in an acute angle to the surface of the workpiece.

6. Cut the board to length.

Prevent tilting over of the board standing out.

7. Check the result.

The boards cut to length are used for the second instruction example.

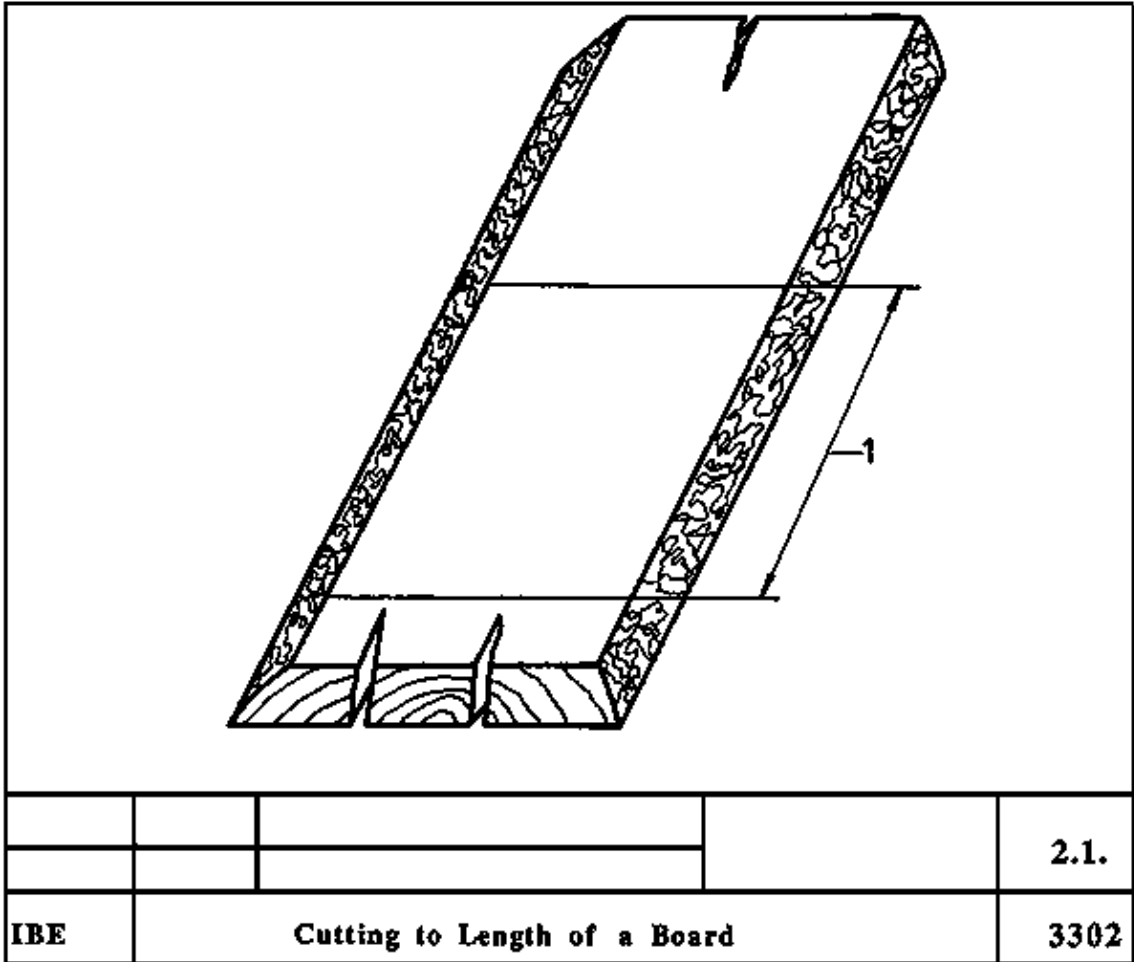

Instruction Example 2.2. Cutting to Length of Strips (Frame Strips)

Strips shall be manufactured from the board cut to length acc. to instruction example 2.1.

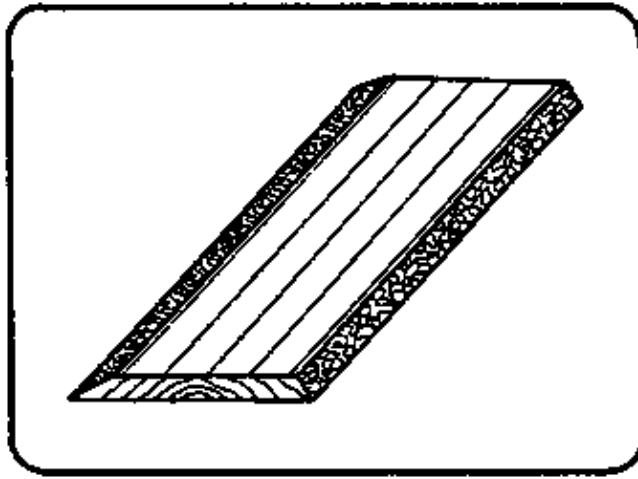

Material

A board cut to length as per instruction example 2.1.

Tools, measuring and testing means

Folding rule, pencil, try square, straightedge, frame saw (ripping saw), pad saw, cutting angle = 90°

Auxiliary accessories

Saw horses, carpenter's bench

Necessary previous knowledge

Measuring, scribing, reading of drawings

Sequence of operations	Comments
1. Prepare the working place.	Check for completeness.
2. Place the material on the bench.	
3. Scribe the side line on the natural bevel and the width lines of the strips.	Consider the width allowance and the cuts.
4. Clamp the workpiece in such a way that the cutting line runs parallel to the bench's edge.	When cutting to length with the grain <i>push-type cutting teeth</i> are required; check the sharpness of the saw.
5. Select and check the saw.	
6. Cut off the natural bevel (edging).	
7. Clamp the workpiece again.	

8. Cut off the strips.

Repeat until the required number of strips is produced.

9. Check the result.

The produced strips are used for the instruction example 2.3.

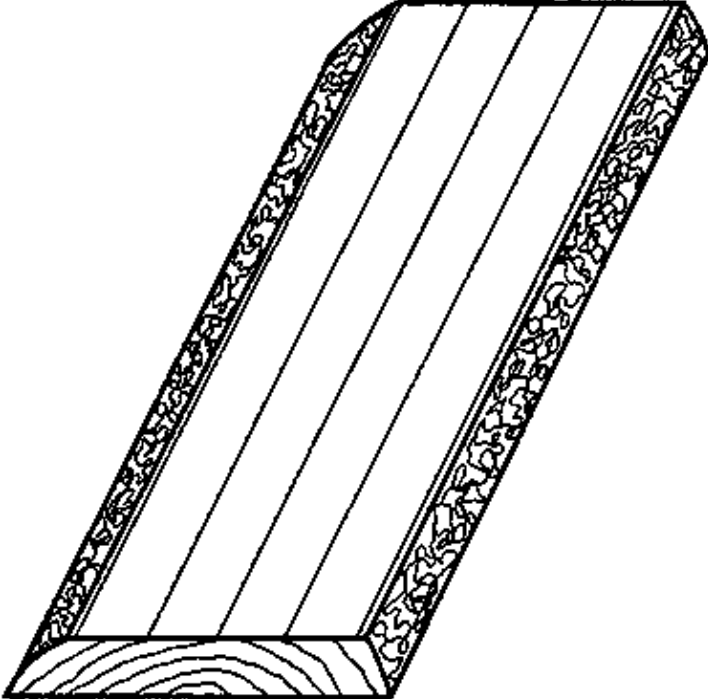

				2.2.
IBE	Cutting to Length of Strips (Frame Strips)			3302

Instruction Example 2.3. Overlapping Joint

The strips produced in the previous instruction example are now worked after an intermediate operation (planing). Now fine cuts with the grain and across the grain shall follow to manufacture wood connections.

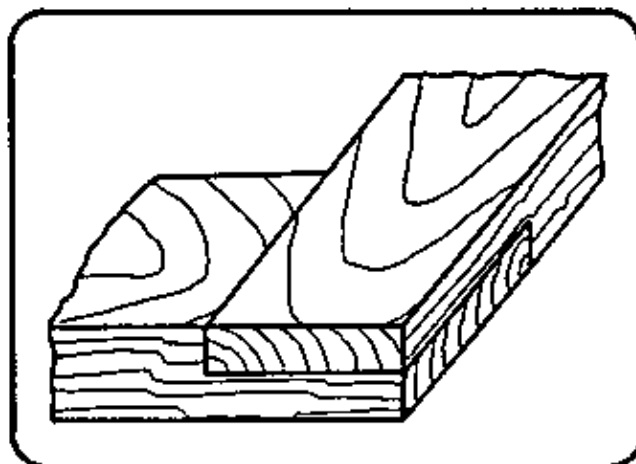

Material

Cut to length and planed out strips from the instruction example 2.2.

Tools, measuring and testing means

Folding rule, pencil, try square, marking gauge, slitting saw, fine tooth wood saw

Auxiliary accessories

Carpenter's bench

Necessary previous knowledge

Measuring, scribing, reading of drawings

	Sequence of operations	Comments
1.	Prepare the working place.	Check for completeness.
2.	Draw the frame strips together.	The best side of the frame strips shows in-wards; mark as datum edge.
3.	Scribe all length sizes (length of the frame wood and of the overlapping wood).	Clamp and scribe parallel strips together.
4.	Scribe the working sizes along the thickness of the workpiece.	With a workpiece thickness of "a" the thickness of the half joint should be "a/2".
5.	Clamp the frame strips vertically.	
6.	Check the slitting saw.	
7.	Saw with the grain.	Guide the saw horizontally and steadily; leave half of the scribed line.
8.	Clamp the frame strips horizontally.	
9.	Check the fine tooth wood saw.	
10.	Cut the steps of the half joint.	A precise cut is necessary for the tightness of the joints.
11.	Check the result.	

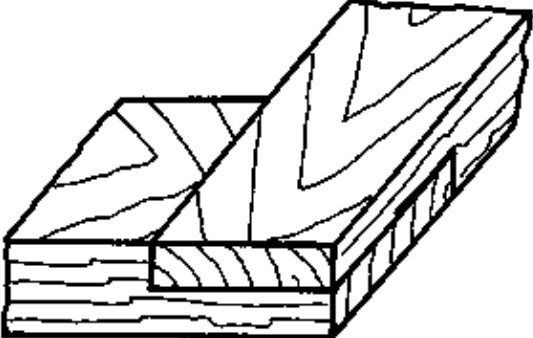
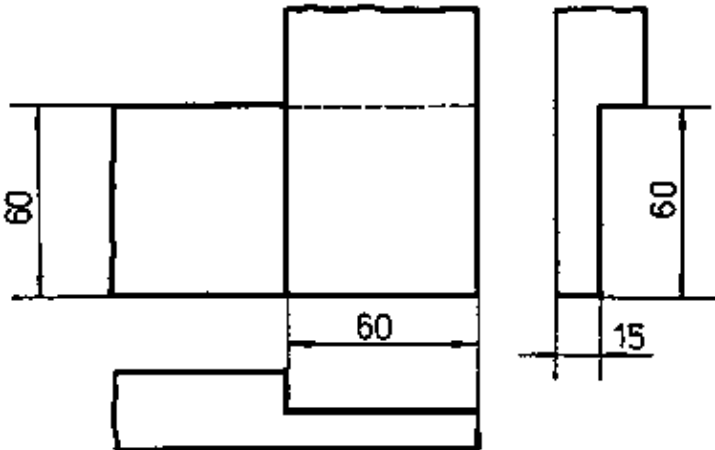
			
			
			2.3.
IBE	Overlapping Joint		3302

Instruction Example 2.4. Cutting of Plies

The cutting of panels shall be practised on chipboards, fibreboards and plies.

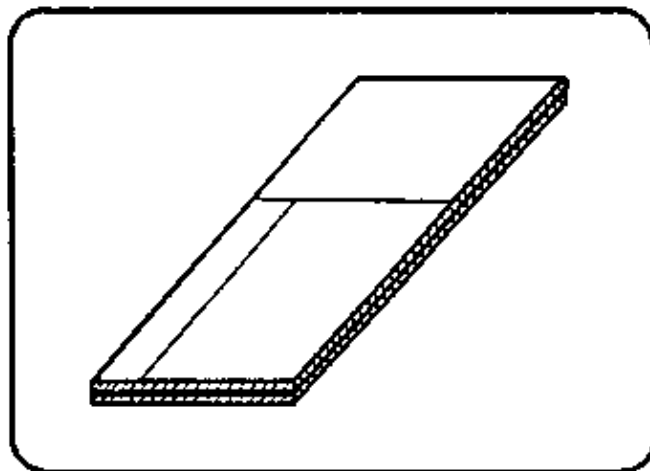

Material

A ply

Thickness: 4 mm

Tools, measuring and testing means

Folding rule, pencil, try square, straightedge, frame saw and pad saw (push-and-pull type cutting teeth)

Auxiliary accessories

Saw horses, carpenter's bench

Necessary previous knowledge

Structure of a ply, measuring, scribing, reading of drawings

Sequence of operation	Comments
1. Prepare the working place.	Check for completeness.
2. Place the ply on the bench.	
3. Select and mark the datum edge.	It should be straight and undamaged.
4. Scribe the width of the workpiece.	Take into account the working allowance and mark the cutting line with the straightedge.
5. Select and check the saw.	Select a frame saw or a pad saw depending on the accessibility of the cutting line.
6. Cut off.	
7. Scribe the cross cuts by means of the try square.	Take into account the working allowance.
8. Perform crosscutting.	Attention with the end of the cut – prevent splintering!
9. Check the result.	The panel can be used to fill the frame from the instruction example 2.3.

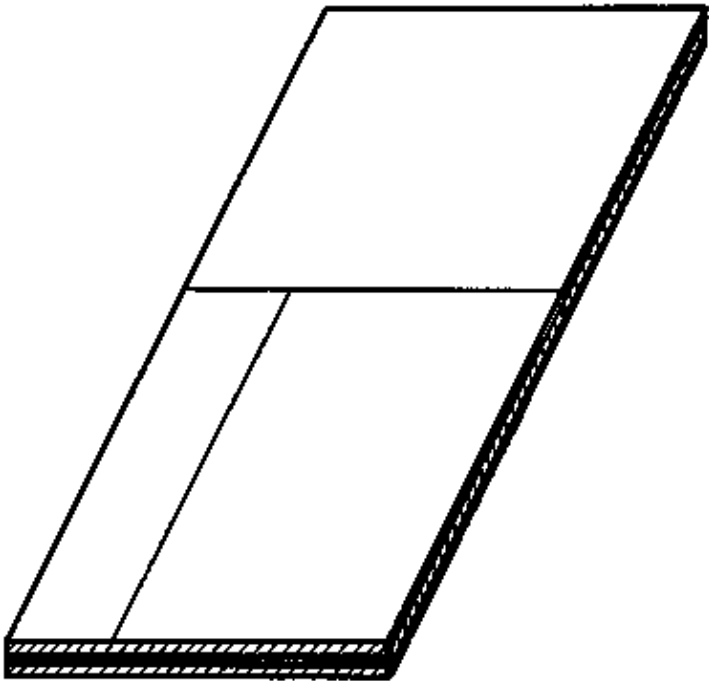
			
			2.4.
IBE	Cutting of Plies		3302

Instruction Example 2.5. Curves

Practising of curve-shaped cuts on solid wood and on panel material made of wood

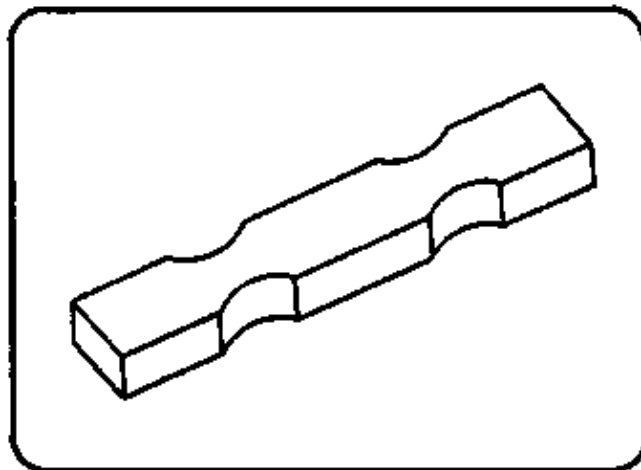

Material

Planed boards

Length: 1000 mm

Width: 100 mm

Thickness: 20 mm

Tools, measuring and testing means

Folding rule, pencil, try square, stencil, fret saw

Auxiliary accessories

Carpenter's bench

Necessary previous knowledge

Measuring, scribing, handling of stencils, sawing with the grain and sawing across the grain

Sequence of operations	Comments
1. Prepare the working place.	Check for completeness.
2. Place the material on the bench.	
3. Scribe the curves.	Measure the position of the curves and mark the cutting line with the help of the stencil, take into account the working allowance.
4. Clamp the workpiece vertically.	
5. Check the fret saw.	Set the saw blade angle.
6. Cut out the curves.	Hold the board at the free end with the left hand.
7. Clamp the workpiece again.	
8. Cut out the rest of the curves.	
9. Check the result.	

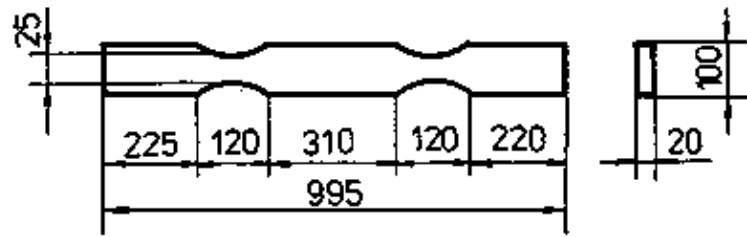
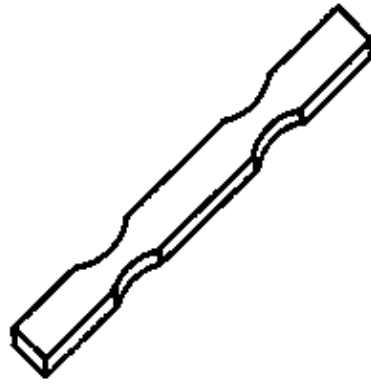

				2.5.
IBE	Curves			3302

