

**Operations on Band and Circular Sawing Machines – Course:
Mechanical woodworking techniques. Trainees' handbook of lessons**

Table of Contents

<u>Operations on Band and Circular Sawing Machines – Course: Mechanical woodworking techniques. Trainees' handbook of lessons</u>	1
<u>1. Purpose of Circular Sawing Operations</u>	1
<u>2. Assembly of a Table Circular Sawing Machine</u>	2
<u>3. Tools</u>	4
<u>4. Mode of Operation of a Circular Sawing Machine</u>	7
<u>5. Circular Sawing Technology</u>	7
<u>5.1. Oblong cuts</u>	7
<u>5.2. Cross and Angular Cuts</u>	9
<u>6. Purpose of Band Sawing Operations</u>	11
<u>7. Assembly of a Band Sawing Machine</u>	11
<u>8. Tools</u>	15
<u>9. Mode of operation of a band sawing machine</u>	16
<u>10. Band Sawing Technology</u>	17
<u>10.1. Oblong and Cross-cuts</u>	17
<u>10.2. Curved Cuts</u>	17

Operations on Band and Circular Sawing Machines – Course: Mechanical woodworking techniques. Trainees' handbook of lessons

Institut für berufliche Entwicklung e.V.
Berlin

Original title:

Arbeitsmaterial für den Lernenden
"Arbeiten an Band- und Kreissägemaschinen"

Author: Johannes Schollbach

First edition © IBE

Institut für berufliche Entwicklung e.V.
Parkstraße 23
13187 Berlin

Order No.: 93–35–3401/2

1. Purpose of Circular Sawing Operations

Circular sawing machines are used for sawing straight-line oblong, cross and angular cuts in solid wood and sheet material.

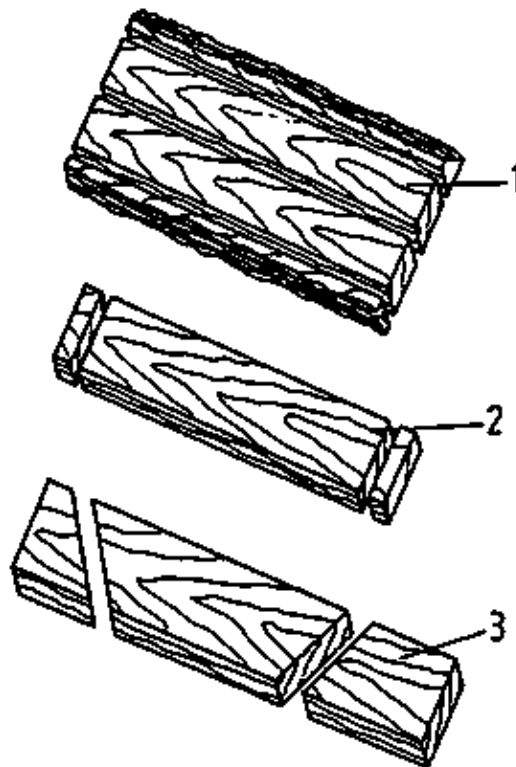

Figure 1 Circular saw machine operations 1 oblong cut, 2 cross-cut, 3 angle cut

Solid woods are seamed and sheet material cut down to width through oblong cuts. Solid woods and sheet material are cut to length through cross and angular cuts.

Which cut varieties are possible on circular sawing machines?

Different types of circular sawing machines are used in wood workshops, for example:

– table circular sawing machine:

is used for straight–line oblong, cross and angular cuts as the most common circular sawing machine

– double–format circular sawing machine:

is used for straight–line and parallel form cuts, particularly of sheet material, is in furniture construction

– hand circular saw:

used for oblong and cross cuts of solid wood and sheet material on building sites and during assembly work.

2. Assembly of a Table Circular Sawing Machine

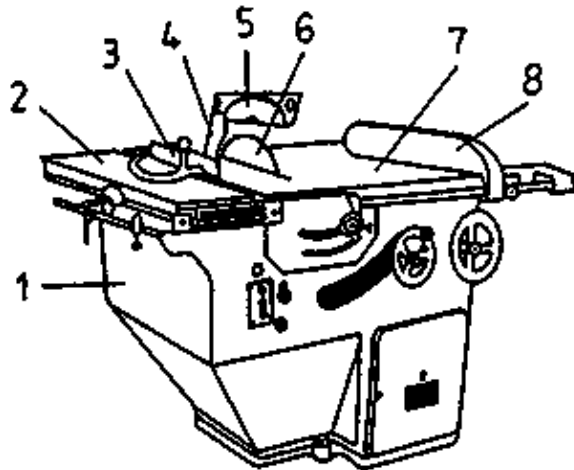

Figure 2 Assembly of a table circular sawing machine 1 stand, 2 receding table, 3 stop for cross and angle cuts, 4 splitting wedge, 5 guard hood, 6 saw blade, 7 machine table, 8 stop rule

Stand

The stand bears the machine table and movable receding table and also houses the height–adjustable motor.

Machine table

The machine table is directly attached to the stand and serves to direct the workpieces to the saw blade.

A stop rule which is adjustable and parallel to the saw blade is on the machine table – to the right of the saw blade. This stop rule serves to set the width of oblong cut workpieces.

Receding table

This is positioned in a movable manner vis-a-vis the stand and serves to undertake cross and angular cuts whose angle setting can ensue by means of a stop.

Motor, motor shaft and saw blade

Motor and motor shaft can be adjusted up to an angle of 45° by means of hand wheels. The saw blade is attached to the saw shaft by means of two flanges and a chucking nut.

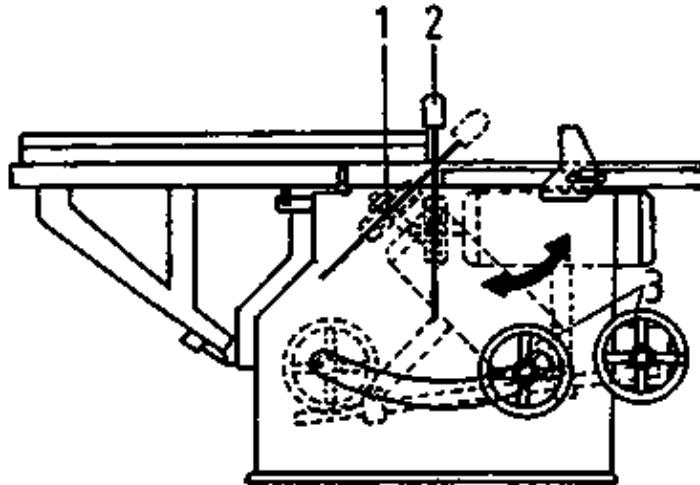

Figure 3 Adjusting the saw blade 1 saw blade at maximum angle setting at 45° – motor swiveling, 2 saw blade in vertical position with motor in horizontal position, 3 hand wheels to adjust the motor

The table edges close to the saw blade and the machinable material are interchangeable.

The distance between saw blade and table edges must not be greater than 3 mm in order to prevent the drawing in of narrow wood pans!

Protective facilities

Splitting wedge and guard hood are protective devices of the circular sawing machine. The machine shall not be used without these protective facilities, otherwise considerable accident risk!

The splitting wedge is adjustable and aligned to the curve of the saw blade whereby the distance from saw blade shall not exceed 10 mm!

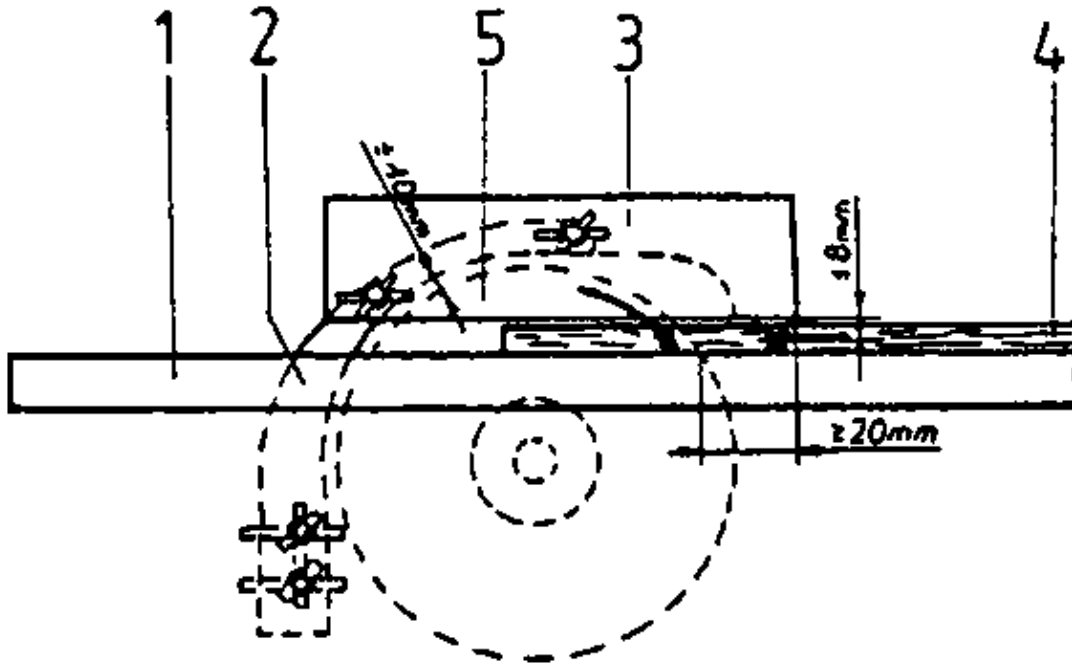

Figure 4 Required protective distances 1 machine table, 2 splitting wedge, 3 guard hood, 4 workpiece, 5 saw blade

The splitting wedge is safeguarded from slipping, adjusting or moving upwards and shall keep apart the separated workpieces thereby ruling out upward and backward sliding of the workpiece. The guard hood is attached to the splitting wedge and consists of machinable material. The saw blade is thus covered up from above. Chips arising are deflected through an escape slot.

The guard hood must protrude 20 mm above the cutting circle of the saw blade feed in the machine table!

Distance of guard hood to workpiece surface shall not exceed 8 mm in rest position!

During the cutting operation the guard hood shall only expose the saw blade section required for cutting. After the cutting operation is over the saw blade must be completely concealed.

If these hints are not observed serious accidents may result!

What is the purpose of the splitting wedge?

What is the purpose of the receding table?

What is the stop rule employed?

3. Tools

The circular saw blades are the tools of the circular sawing machine. These saw blades are circular-shaped steel disks with spikes which may be differently shaped.

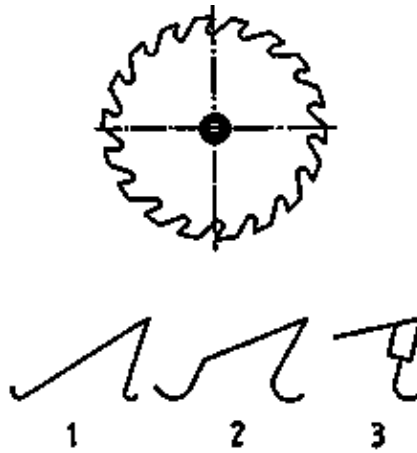

Figure 5 Teeth shapes of circular saw blades 1 acute–angled tooth (normal tooth), 2 gullet tooth, 3 tooth with hard metal tips

These saw blades are suitable for the following applications given normal strain in hand feed operation:

- saw blade with sharp–angled tooth (normal tooth): oblong and cross cuts of hard wood, soft wood and sheet material
- saw blade with gullet tooth: oblong cuts of hard wood, moist and dry soft wood
- saw blade with hard metal tool tips: oblong and cross cuts of hard and compact wood varieties, chip– and fibreboards, plastic materials

Circular saw blades with sharp and gullet teeth are usually saw set whereby the teeth may be bent to the right or left (setting width of 0.3 to 1.0 mm).

In the case of circular saw blades with hard metal tool tips the cutting tip of the cutting edge is wider than the backing material of the saw blade.

In order to prevent the saw blades from jamming in the kerf and to avoid frictional saw blade heating, the saw blades must cut "freely".

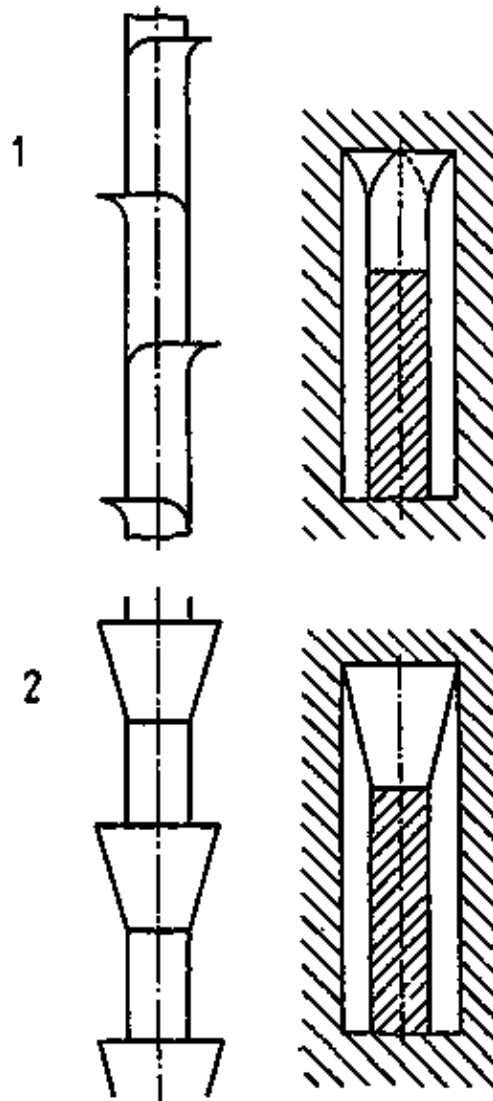

Figure 6 Free cut of saw blades 1 setting of normal teeth, 2 relief grinding for hard metal cutting tips

The following hints are to be taken into consideration:

Check condition of circular saw blade before using!

Do not use cracked, deformed, wobbling and unbalanced saw blades!

Do not exceed the top speed indicated on the saw blades!

Blunt and resined saw blades must be replaced.

In the case of reground hard metal tipped circular saw blades the cutting tip thickness must be at least 2 mm.

Hard metal tipped saw blades with successively impaired cutters or cutters more than 10 per cent worn shall no longer be used.

Which saw blades are used for cutting hard wood, soft wood and sheet material?

How can unimpeded cutting of various circular saw blades be guaranteed?

4. Mode of Operation of a Circular Sawing Machine

The saw blade brought into play by an electric motor separates solid wood and sheet material longitudinally and crosswise to grain direction.

Stop rule and receding table facilities permit the cutting of size-accurate workpieces. This results in a rough cutting edge which must be further processed.

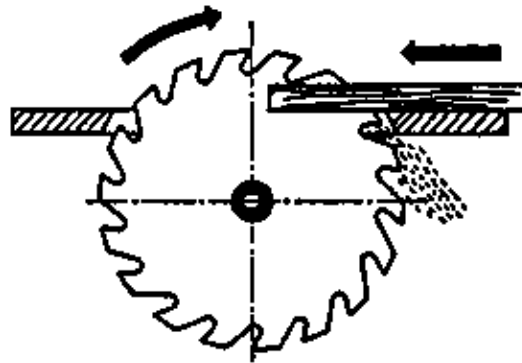

Figure 7 Mode of operation of circular sawing

5. Circular Sawing Technology

5.1. Oblong cuts

Marking the workpiece:

Marking ensues with pencil and straight edge in line with the sizes cited in the technical drawing or the widths of the unseamed plank edges. The seam cut is so marked that the uneven, rind-covered narrow face falls down after cutting and the board has rectangular outer edges.

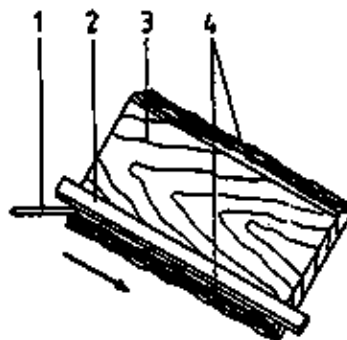

Figure 8 Marking the hem cut 1 pencil, 2 straight edge, 3 plank face, 4 seam edges

Setting up the circular saw:

The saw blade with the desired tooth form is chucked in line with the material being processed whereas the projection depends on the workpiece thickness. Subsequently splitting wedge and guard hood are set.

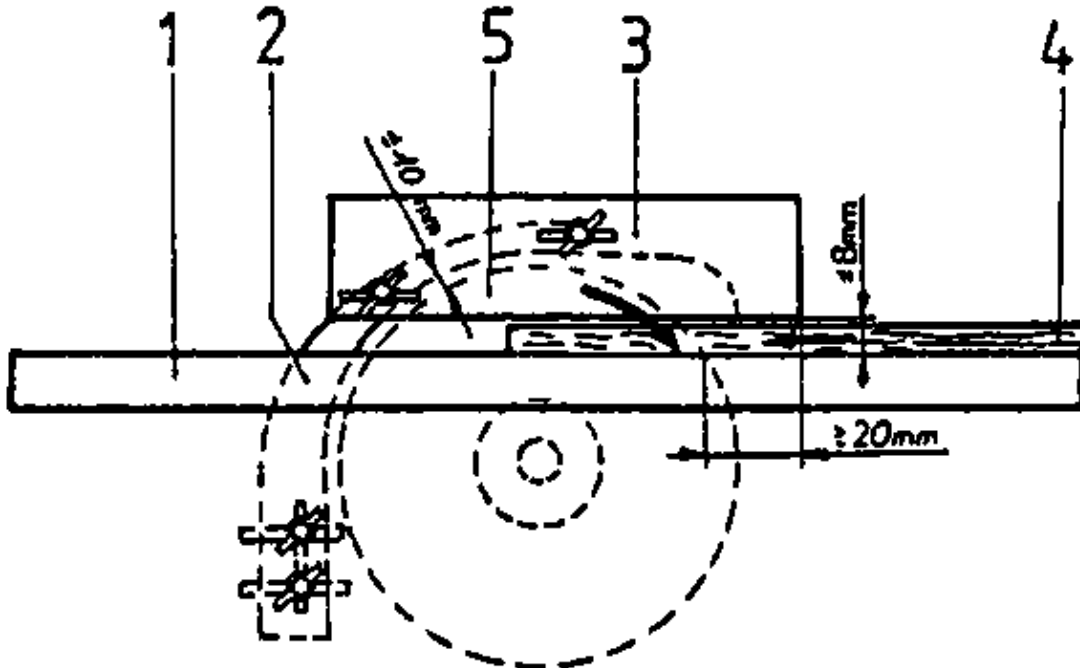

Figure 9 Setting up the circular saw 1 machine table, 2 splitting wedge, 3 guard hood, 4 workpiece, 5 saw blade

Saw cut execution:

The machine is switched on. Check saw blade for smooth running.

Unseamed planks are sawn freehand according to marking. Grip and guide the plank to the side of the marking.

Following the seam cut, the stop rule is set to the desired board width. By means of the feed strip the board at the stop rule is pushed through the saw blade.

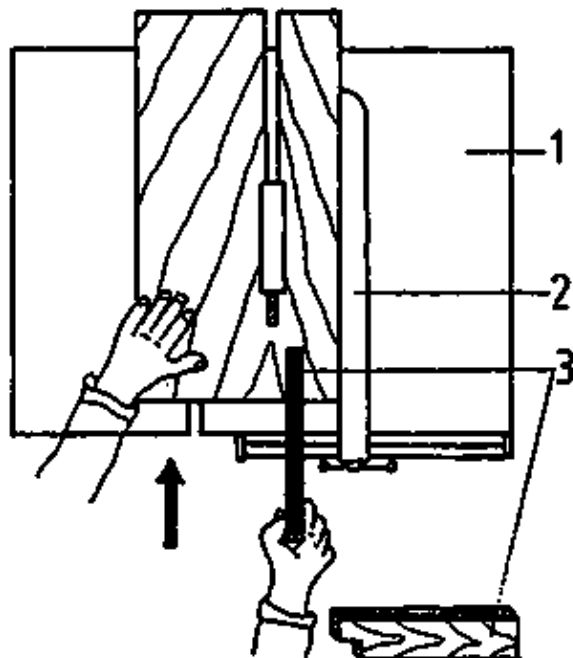

Figure 10 Sawing oblong cuts 1 machine table, 2 stop rule, 3 feed strip

Employ noise reduction means!

Check the saw cuts:

Size control ensues by means of the folding rule. The evenness of the cut edges is checked using the straight edge or visually.

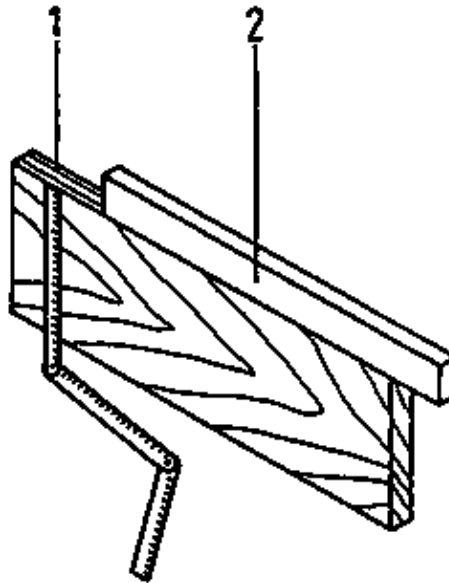

Figure 11 Controlling saw cuts *1 size control with folding rule, 2 evenness control with straight edge*

Reset the stop rule if board width inaccuracies arise. After sawing, switch off the machine and remove saw chippings to prevent stumbling.

How is the seam cut marked?

What must be heeded when setting up the circular saw?

Why must a feed strip be used?

5.2. Cross and Angular Cuts

Producing a reference edge:

The board is cut laterally or at the required angle on one end face. Commensurately, set the stop on the receding table to which the board is positioned during sawing. The cross-cut is so marked that minimal cut-back results.

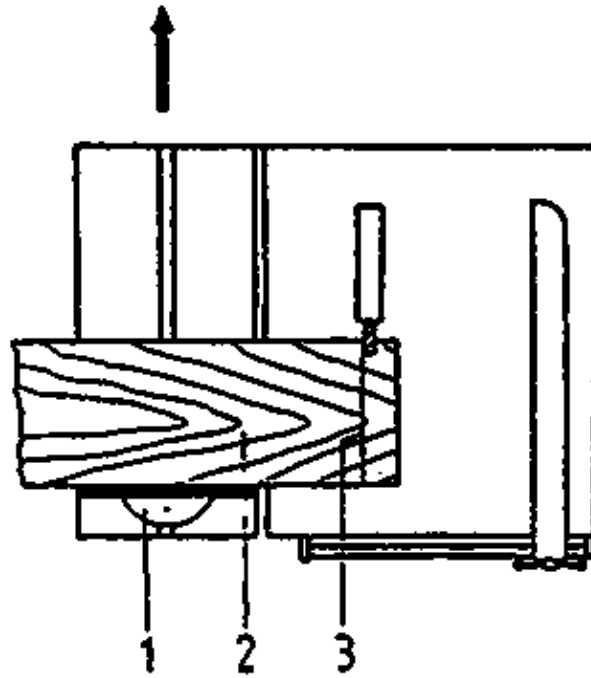

Figure 12 Producing a reference edge 1 stop on machine table, 2 workpiece, 3 mark

Marking the length:

The required length is marked at the other board end or at the stop of the receding table in line with the lateral or angle cut.

Sawn kerf execution:

The plank with the receding table is fed slowly through the saw blade.

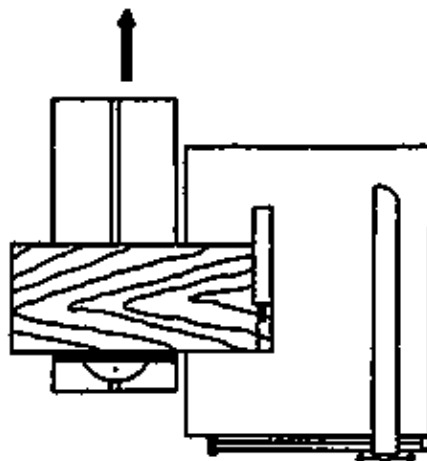

Figure 13 Saw cut with the receding table

Checking size consistency:

The size consistency of lengths is checked by means of the folding rule. Rectangular cross-cuts are checked using the try square. Mitre cuts of 45° are checked by means of a mitre angle of 45° or 135° whilst an angle measuring device is used for other angles.

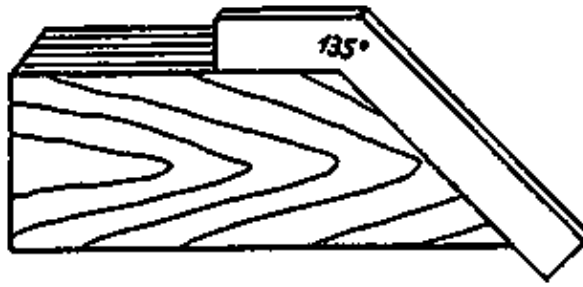

Figure 14 Checking mitre angle

How can angle cuts be accurately attained?

Which operation precedes marking the precise length of a workpiece?

6. Purpose of Band Sawing Operations

Band sawing machines are used for sawing straight-line oblong, cross and angle cuts, equally for curved cuts (curves) of solid wood and sheet material.

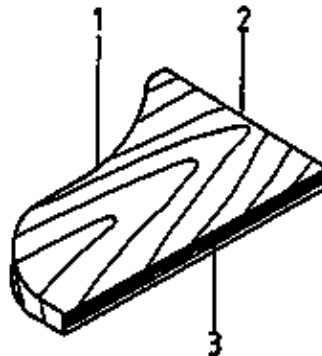

Figure 15 Band sawing machine operations *1 curved cut, 2 cross-cut, 3 oblong cut*

Which main difference is there between using a band sawing machine and a circular sawing machine?

7. Assembly of a Band Sawing Machine

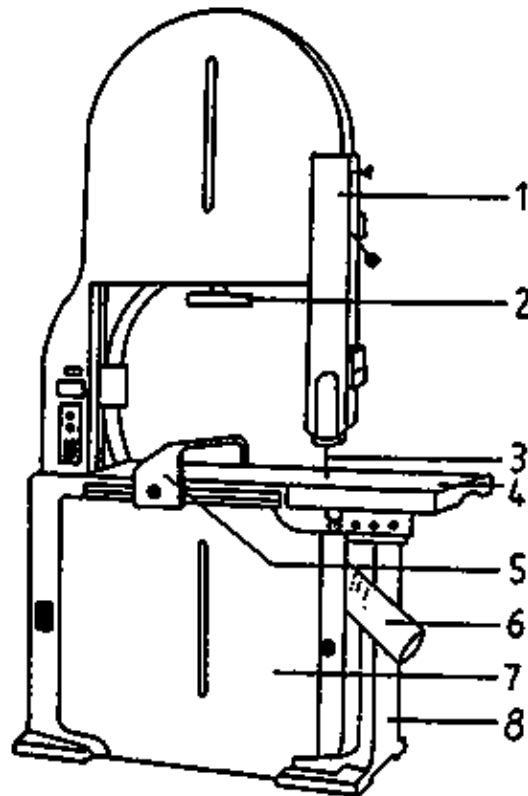

Figure 16 Assembly of a band sawing machine 1 adjustable saw blade sheathing, 2 hand wheel to chuck the saw blade, 3 saw blade, 4 machine table, 5 stop rule, 6 contact/or exhaust facility, 7 casing with lower saw band roll and motor, 8 stand

Stand:

The cast iron stand bears the upper and lower band roll, the machine table and the drive motor of the lower band roll.

Machine table:

The machine table is adjustably supported for undertaking angle cuts. The machine table features an adjustable and pivoted stop rule for parallel cuts.

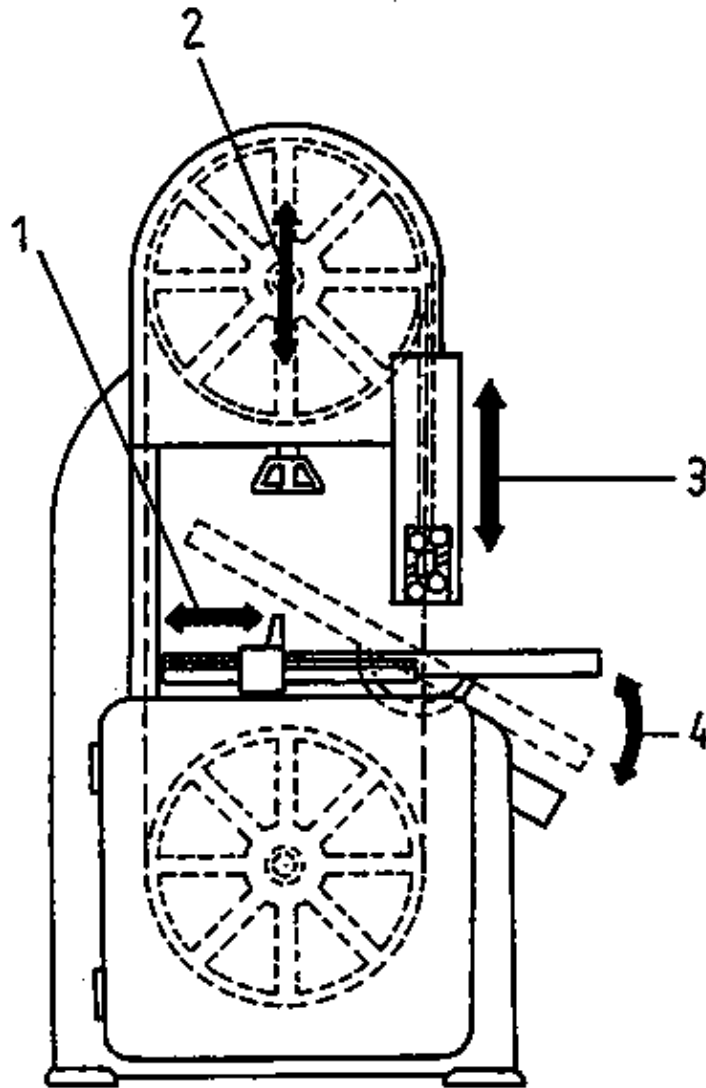

Figure 17 Adjustability of facilities *1 shifting the stop rule, 2 chucking the saw blade, 3 shifting the saw blade sheathing. 4 tilting the machine table*

Band rolls:

The lower band roll is firmly pivoted and driven by a motor.

The top band roll is positioned vertically above the lower band roll. It can be adjusted by means of a hand wheel for chucking the saw blade heightwise.

The shaft of the top band roll is inclined towards the running setting of the band saw blade.

The band rolls have rubber bandages for improved adhesive power of the saw blade.

Check that rubber bandages are clean and not damaged or worn!

Saw blade sheathing:

Both band rolls and the band saw blade section not required for cutting are sheathed. The adjustable saw blade sheathing can be set to the thickness of the material to be cut.

Saw blade guidance:

The top saw blade guidance above the table can be set heightwise to material thickness. The guidance positioned below the machine table is rigid. The saw blade guidance consists of lateral and back guide rolls which absorb the feed pressure of the workpiece.

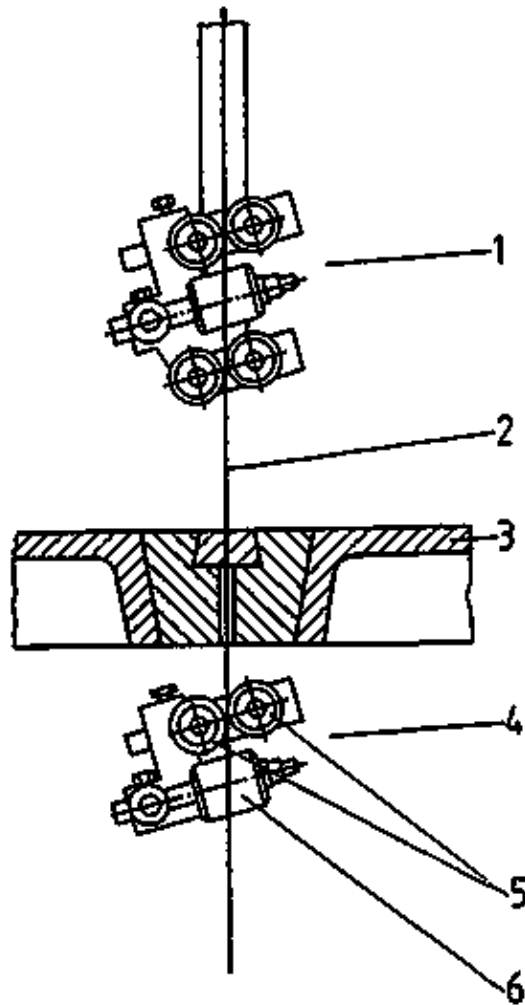

Figure 18 Assembly of saw blade guidance 1 top saw blade guidance, 2 band saw blade, 3 machine table, 4 lower saw blade guidance, 5 lateral guide rolls, 6 rear guide rolls

The saw blade teeth must protrude beyond the guide rolls so that the saw blade slides easily through the guide rolls.

The band saw blade is properly set when the unstressed saw blade extends 2 mm plus tooth height above the lateral guide rolls and is then 1 mm away from the back guide roll.

Regulating the top saw blade guide should be possible without any danger whilst the machine is running!

Saw blade guides must guarantee smooth saw blade running. The saw blade sections not used for sawing should be sheathed until they are shortly beyond the workpiece surface.

The saw blade run of the machine table must not exceed 3 mm in width!

The correct setting of the guide rolls must be constantly checked!

Relieve the saw blade during longer machine standstill periods.

Why is the machine table adjustable?

Why is the top band roll movably pivoted?

Why do the band rolls have rubber bandages?

How shall the saw blade guidance be set?

What must be done during longer machine standstill periods?

8. Tools

The tools of band sawing machines are the band saw blades. They are, in point, saw blades combined into an endless band by means of hard soldering or welding, which may be differently arranged in widths, tooth division and height.

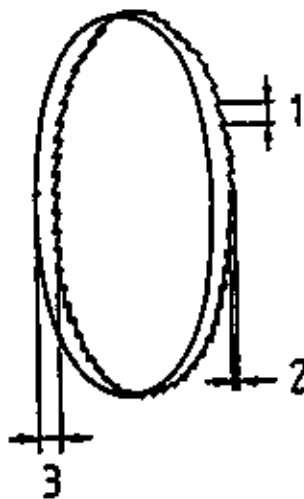

Figure 19 Band saw blade 1 teeth division, 2 teeth height, 3 band width

Generally speaking acute-angled teeth are used. Saw blades with a rough teeth division (8–10 mm) are used for sawing soft wood whilst for hard wood and sheet material saw blades with a smaller teeth division (6–8 mm) are employed. The free cutting of the saw blades is ensured through teeth displacement, less frequently also through linear contraction.

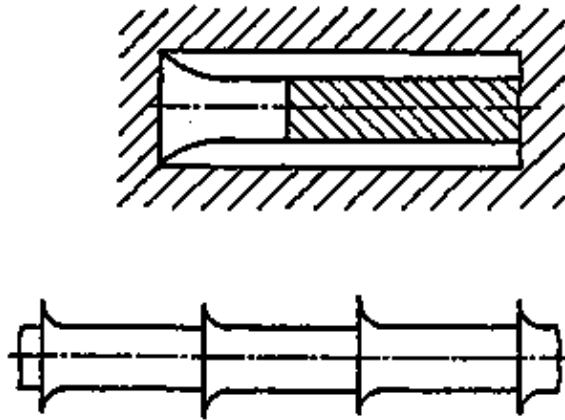

Figure 20 Free cut through saw blade linear contraction

Repairs:

Tom saw bands must be resoldered or rewelded prior to sharpening. The free ends are cut rectangularly, cleaned and inclined to lengths between 10 and 15 mm.

- When the ends are soldered together they must be so positioned to one another that the blade backs at the point of connection are not bent and the original teal division is adhered to. The solder point should re-anneal and only cool off gradually; it is hammered, cleanly filed on both sides and ground to normal blade cross-cut.

- The ends are positioned bluntly to one another, welded and subsequently the welding crust is removed during saw blade welding.

New, freshly soldered or welded saw blades operate idle running for five minutes prior to first actual operations!

Saw blades are stored hung up with the teeth to the wall!

9. Mode of operation of a band sawing machine

The endless saw blade running above the two band rolls separates through chip removal solid wood and sheet material. The small blade width makes possible curved cuts with various fret radii. Parallel, straight-line oblong or cross-cuts can be undertaken at the stop rule. This results in a rough cutting edge which requires further processing.

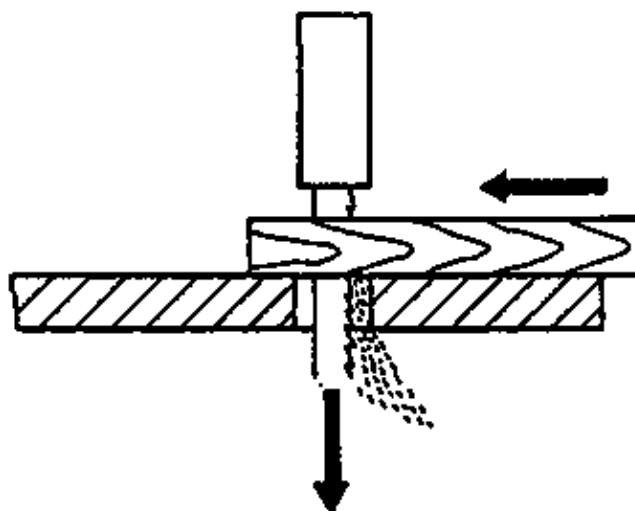

Figure 21 Mode of operation of band sawing

10. Band Sawing Technology

10.1. Oblong and Cross-cuts

Setting up the machine:

A band saw blade is positioned in the desired width according to the material being processed. The guard devices and roll sheathing are opened and the saw blade is chucked. The band sequence is so regulated by setting the batter of the top band roll so that the saw blade teeth are positioned in front of the bandage.

Thereby the band rolls are manipulated manually. The guide rolls above and below the table should be so set that the teeth are positioned in front of the rolls and the blade glides easily between the rolls. There remains an air fissure of one mm between the rear and band rolls. The guard devices and roll sheathing must be ground prior to undertaking a trial run.

Marking the workpiece:

The workpiece is pencil-marked according to the size data of the technical drawing. Given simple, straight cuts the width can be set directly on the stop rule on the machine table.

Saw cutting:

Switch on the machine and ensure smooth saw blade running. Position the workpiece securely in front of the saw band. Use both hands to guide the workpiece and push it slowly through the saw band. An untrue cut may arise through the following shortcomings:

- a too narrow saw blade
- irregular teeth setting
- insufficient saw blade chucking
- a too blunt saw blade
- idle running in the soft annual rings through too great rate of speed

Controlling size consistency:

The sizes are determined by commensurate measuring means.

Which band saw blade is chucked for straight oblong and cross-cuts?

Why must the workpiece not be pushed through at a high rate of speed?

10.2. Curved Cuts

Setting up the machine:

Select the saw band according to the type of material and curve radii:

- narrow saw band for small radii
- wide saw band for wide radii

Commensurately, as already described, set up the machine accordingly.

Marking the workpiece:

Mark the kerf outline on the workpiece surface employing suitable marking means or aids.

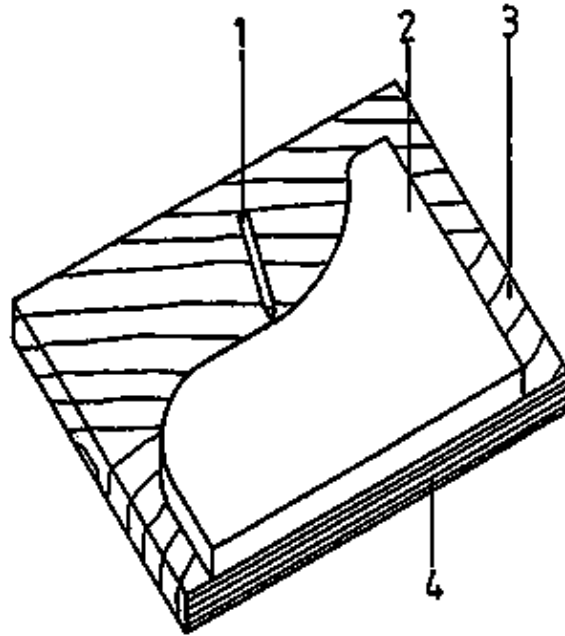

Figure 22 Marking curved cuts with templet 1 pencil, 2 templet, 3 plant, 4 reference edge

Saw cutting:

Hold and guide the workpiece with both hands. It is cut freely at the marked points.

- Always keep hands away from the sawing area!
- Select a slow speed rate!

Checking size consistency:

Check the sizes and curved forms by means of a templet or suitable measuring means.

Which band saw blade is chucked for small radii?

How is a curved kerf attained?
