

[Home](#) > [ar.cn.de.en.es.fr.id.it.ph.po.ru.sw](#)

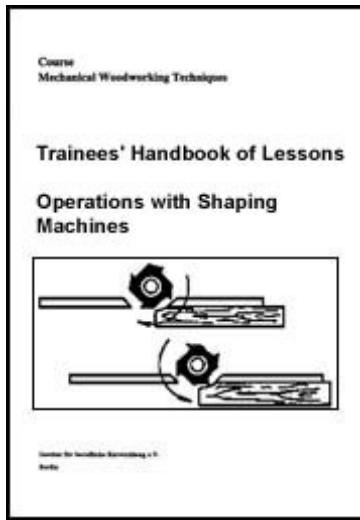

➔ **Operations with Shaping Machines - Course: Mechanical woodworking techniques. Trainees' handbook of lessons (Institut fr Berufliche Entwicklung, 18 p.)**

(introduction...)

1. Purpose of Shaping Machine Operations

2. Construction of a Shaping Machine

3. Tools of a Shaping Machine

4. Mode of Operation of a Shaping Machine

5. Servicing and Looking After the Machine

6. Labour Safety Measures



[Home](#) > [ar.cn.de.en.es.fr.id.it.ph.po.ru.sw](#)

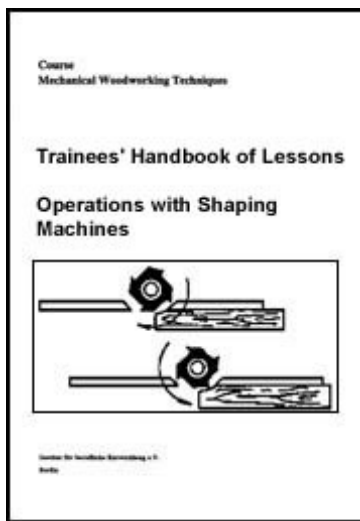

Operations with Shaping Machines - Course: Mechanical woodworking techniques. Trainees' handbook of lessons (Institut fr Berufliche Entwicklung, 18 p.)

➔ **(introduction...)**

1. Purpose of Shaping Machine Operations

2. Construction of a Shaping Machine

3. Tools of a Shaping Machine

4. Mode of Operation of a Shaping Machine

5. Servicing and Looking After the Machine

6. Labour Safety Measures

**Institut fr berufliche Entwicklung e.V.
Berlin**

**Original title:
Arbeitsmaterial fr den Lernenden
"Arbeiten an Unterfrsmaschinen"**

Author: Gnter Hanisch

First edition © IBE

**Institut fr berufliche Entwicklung e.V.
Parkstrae 23
13187 Berlin**

Order No.: 93-35-3404/2



[Home](#) > [ar.cn.de.en.es.fr.id.it.ph.po.ru.sw](#)

 **Operations with Shaping Machines - Course: Mechanical
woodworking techniques. Trainees' handbook of lessons
(Institut fr Berufliche Entwicklung, 18 p.)**

 **(introduction...)**

-   **1. Purpose of Shaping Machine Operations**
-  **2. Construction of a Shaping Machine**
-  **3. Tools of a Shaping Machine**

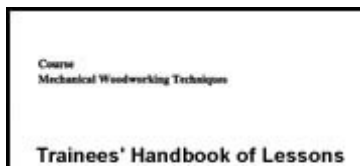

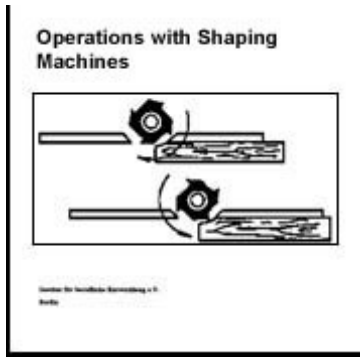

- 4. Mode of Operation of a Shaping Machine
- 5. Servicing and Looking After the Machine
- 6. Labour Safety Measures

1. Purpose of Shaping Machine Operations

Shaping machines are wood-working devices used mainly for chip-forming cutting of workpieces (narrow faces). Milling results in workpiece profiles.

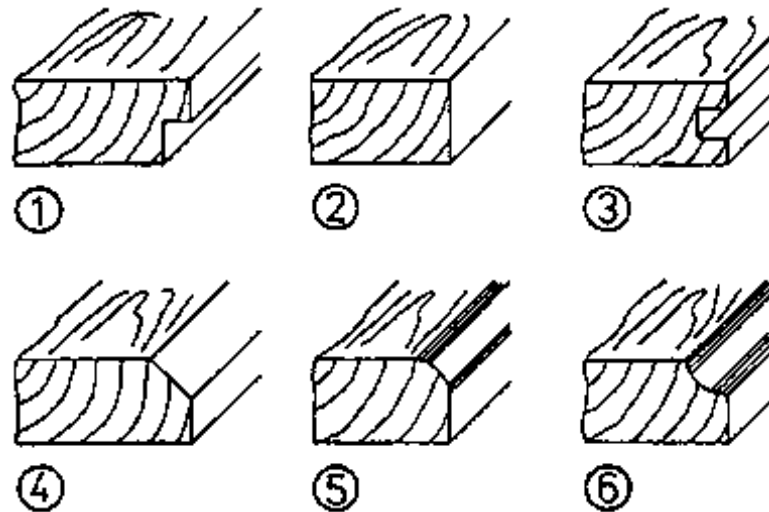

Figure 1 - Simple workpiece profile forms

(1) fold, (2) plane, (3) slot, (4) grain, (5) quarter round, (6) quarter chamfer

A combination of various basic profiles can also be realised.

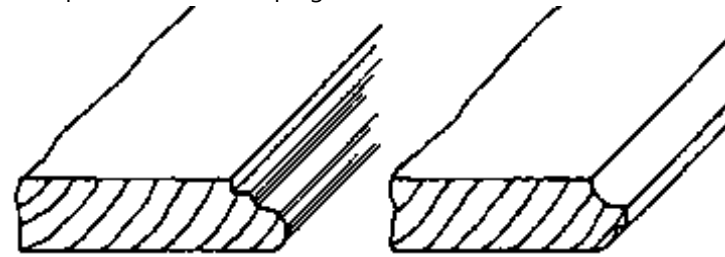

Figure 2 - Profile combinations

The combination of profiled faces ensues in various wood connections in furniture construction (tables, cupboards) and when making doors and windows.

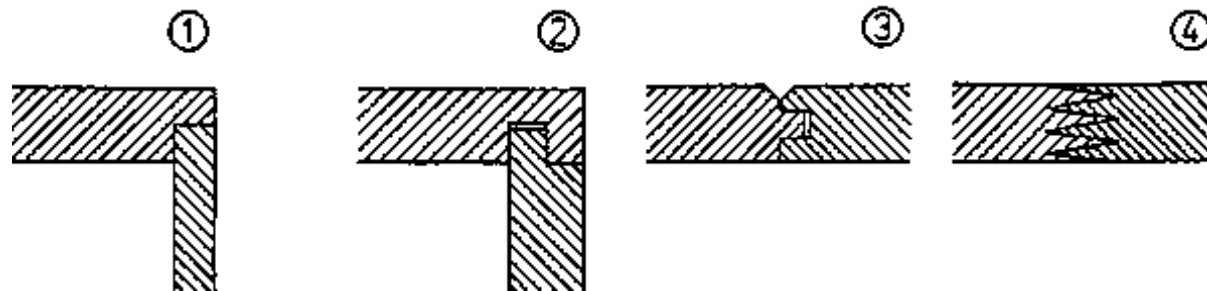

Figure 3 - Examples of wood connections (joints)

(1), (2) face corner joints, (3), (4) lateral joints

What is the purpose of milling?



[Home](#) > [ar](#).[cn](#).[de](#).[en](#).[es](#).[fr](#).[id](#).[it](#).[ph](#).[po](#).[ru](#).[sw](#)

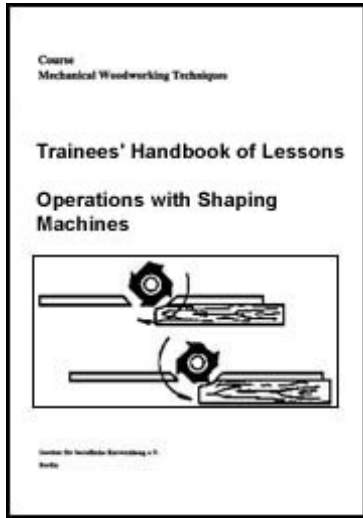

 **woodworking techniques. Trainees' handbook of lessons (Institut für Berufliche Entwicklung, 18 p.)**

 **(introduction...)**

 **1. Purpose of Shaping Machine Operations**

 **➔ 2. Construction of a Shaping Machine**

 **3. Tools of a Shaping Machine**

 **4. Mode of Operation of a Shaping Machine**

 **5. Servicing and Looking After the Machine**

 **6. Labour Safety Measures**

2. Construction of a Shaping Machine

A shaping machine consists in the main of a machine frame with a stationary resp. movable machine table, the milling support, cutter arbor, guide rule with exhaust cap, drive facilities with operating elements and labour safety provisions.

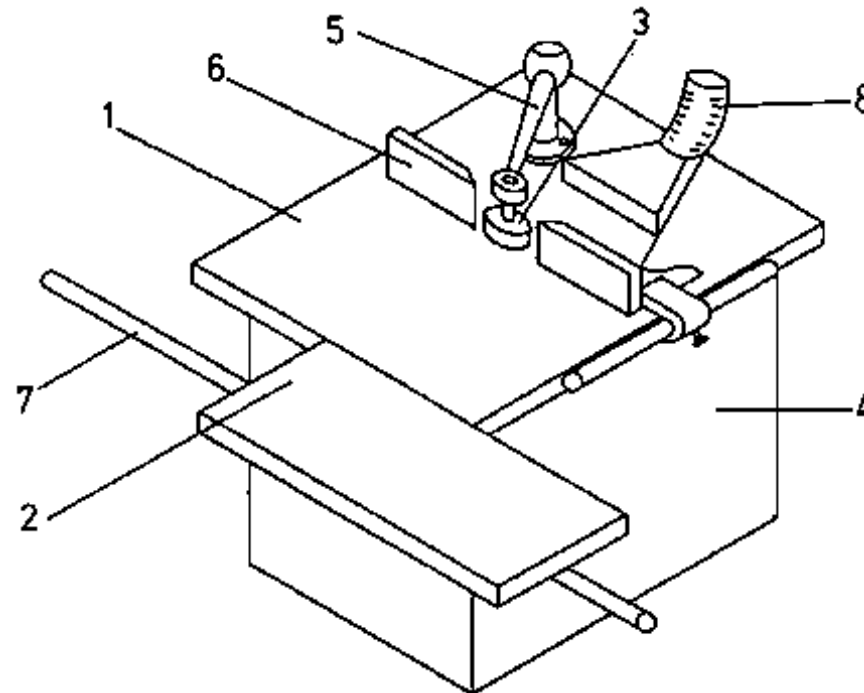

Figure 4 - Shaping machine

1 machine table, 2 movable table, 3 cutter arbor with tool, 4 machine frame, 5 top bearing support with top bearing, 6 guide rule with stop faces, 7 guide tube, 8 exhaust facility

The machine table is plane and smooth and features a circular shaped opening to absorb the cutter arbor. The opening has a diameter of 260 mm and is aligned to the processing job in hand by means of table spacers. The machine table also features throughgoing tap holes for attaching additional aids.

The movable section of the table makes it possible to chuck on bigger workpieces to the table.

This improve work safety, particularly when larger tools are used, for instance when

undertaking tenon milling. A boom for the top bearing can be mounted onto the stationary section of the table. This is, moreover, essential when using heavy tools on a cutter arbor with top bearing tenon. The top bearing protects the cutter arbor and spindle from damage through overloading.

Milling support

This consists in the main of a milling spindle, a guide facility for adjusting the height of the milling spindle and operating elements for the height adjustment. The milling spindle has precision running in bearings. Felt spacers prevent the penetration of dust into the bearings. The top section of the spindle, the spindle neck, features a coned bore.

No dirt must enter this bore whilst the cutter arbor is changed. Otherwise the fitting is destroyed and the cutter arbor does not run centrally.

The spindle neck has an external thread and features a sleeve nut for attaching the cutter arbor. Two belt pulleys are attached to the lower end of the milling spindle for the selective setting of two speed variants.

Cutter arbor

Cutter arbors with a shaft diameter of between 25 and 30 mm are used for normal shaping machine operations. Cutter arbors with or without top bearing tenons are used depending on the size of tools employed and rotational speed load.

Cutter arbors with top bearing tenons may only be used with top bearings!

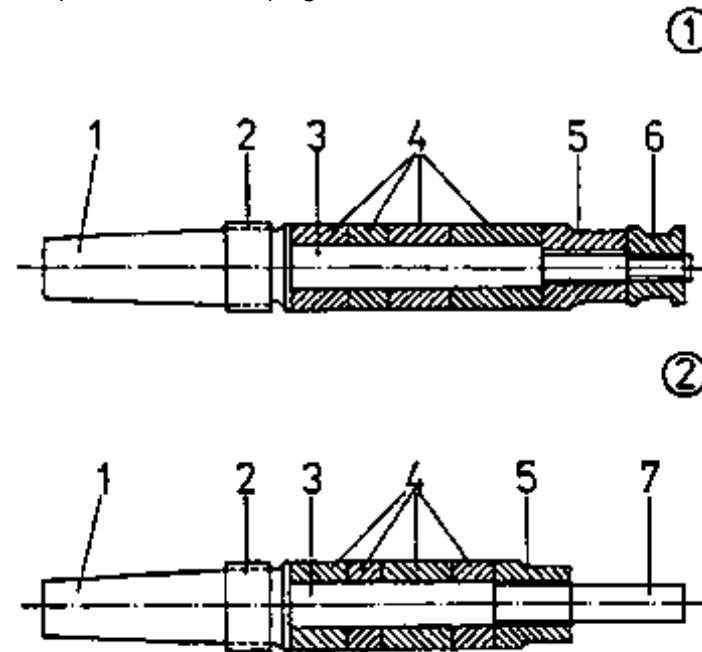

Figure 5 - Cutter arbors

- (1) cutter arbor without top bearing tenons,
(2) cutter arbor with top bearing tenons**

***1 morse taper, 2 differential thread, 3 cutter arbor shaft, 4 cutter arbor spacers,
5 cutter arbor nuts, 6 safety nut, 7 top bearing tenon***

The cutter arbor is securely connected to the spindle by means of the Morse taper and differential nut thread. The spindle thread features a lesser increment than the cutter arbor thread (difference = one mm). Ensure when tightening the differential nut that already slight wrench tightening gives rise to considerable chucking stress in the Morse taper fitting. For that reason a wrench extension should not be used when tightening the cutter arbor nut. The inserted cutter arbor must clearly feature two thread leads above the differential nut.

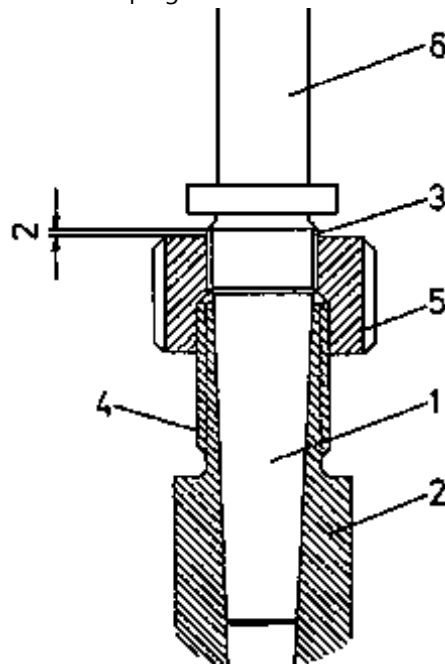

Figure 6 - Spindle neck with assembled cutter arbor

1 morse taper, 2 spindle neck, 3 differential thread (cutter arbor), 4 differential thread (spindle neck), 5 differential nut, 6 cutter arbor shaft

The cutter arbor spacers of differing thicknesses permit the mounting of milling tools of varying strengths. Try to ensure that the tool attached to the cutter arbors without top bearing tenons is positioned in the lower shaft area.

Minimal unbalance of the tool and uneven processing forces are consequently more easily compensated for by the milling spindle.

The cutter arbor nut with the complete thread engaged is required for tightly chucking the tool. This requirement can be met through a proper selection of the differing cutter arbor spacers.

Where cutter arbors have a shaft diameter of 25 mm the cutter arbor spacers have a height respectively of 5, 8, 10, 16 and 25 mm. The cutter arbor nut has a thread of M24 x 2 or M30 x 2. If (in exceptional cases) the spindle is operated in clockwise rotation with a cutter arbor without top bearing tenons, a safety nut must be counteracted against the cutter arbor nut.

The safety nut has a M16 x 1.5 left thread!

Ensure that the cutter arbor nut is only slightly tightened. On no account extend the wrench, otherwise the cutter arbor will be stressed unduly.

Given anti-clockwise running of the spindle, the moments of inertia of the tool and the cutting forces exert a tightening effect on the cutter arbor nut.

After the cutter arbor nuts have been tightened the locating pin must be removed from the lower section of the milling spindle.

The drive motor can be seriously damaged if the machine is switched on whilst the spindle is arrested!

Why are cutter arbor spacers of differing thicknesses used to attach the tool?

Why must a safety nut with left thread be used additionally on cutter arbors without top bearing tenons given clockwise rotation of the machine?

Drive

The drive motor is a pole-changeable three-phase synchronous motor. Its performance level is geared to the machine size. The motor can be switched to two varying speeds.

Motor speed 1 = 1450 min⁻¹

Motor speed 2 = 2880 min⁻¹

Thus, four spindle speeds can be set if the driving belt is selectively aligned to one of the two belt pulley pairs.

Switch position:

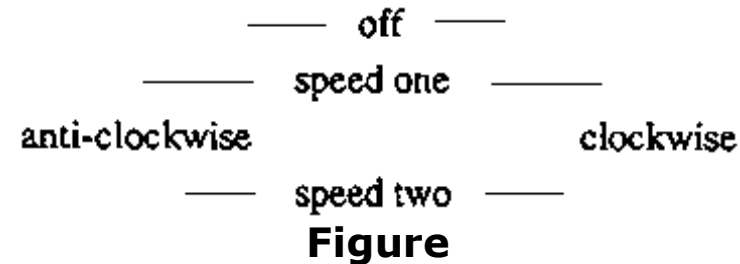

Rotational speed settings:

Pulley setting	Switch setting	Spindle rotational speed (min⁻¹)
I	1	3000
I	2	6000
II	1	4500
II	2	9000

Provided the spindle rotational speed is properly selected, a favourable cutting speed conforming to the material being processed can be attained for each tool diameter.

Survey 1

Cutting speed in $\text{m} \cdot \text{s}^{-1}$

1 tool of quick cutting steel,

2 tool with hard metal cutters,

3 soft wood,

4 hard wood,

5 chipboard,

6 hard board,

7 plywood,

8 thermoplast,

9 phenoplast

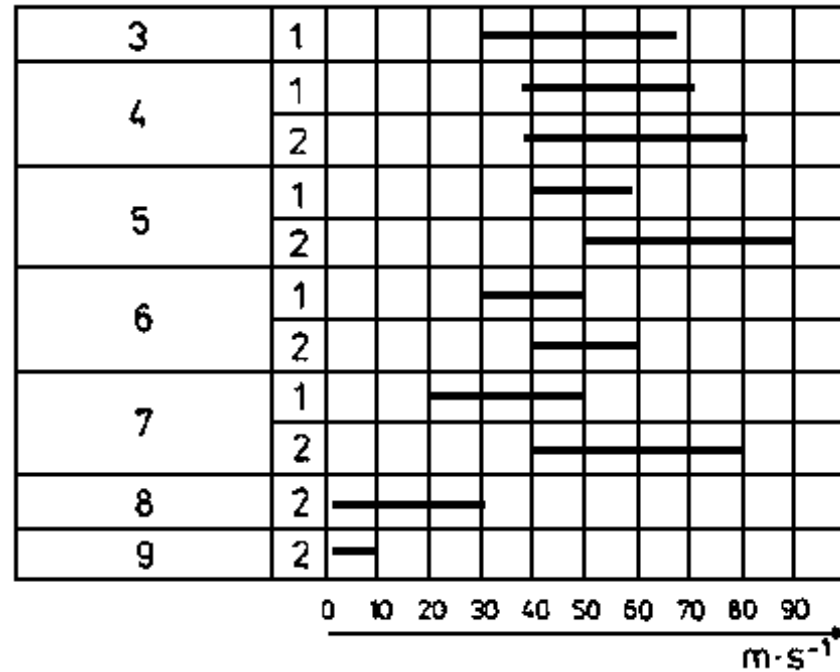
**Figure**

The required spindle rotational speed can be determined from the formula

$$n = \frac{v}{d \cdot \pi}$$

n = rotational speed of the machine spindles min^{-1}

v = cutting speed $\text{m} \cdot \text{s}^{-1}$

π = constant = 3.14....

d = knife cutting circle m

Example:

In order to mill a slot a cylindrical cutter with a knife cutting circle diameter of $d = 125$ mm tool steel shall be used. The workpiece is of soft wood.

According to data in survey I the lowest cutting speed for soft wood shall be $v = 30 \text{ m} \cdot \text{s}^{-1}$. The required spindle rotational speed is unknown.

Solution:

given:

$$d = 125 \text{ mm} = 0.125 \text{ m}$$

$$v = 30 \text{ m} \cdot \text{s}^{-1}$$

$$\pi = 3.14$$

unknown: = n

$$n = \frac{v}{d \cdot \pi}$$

$$n = \frac{30 \text{ m} \cdot 60}{\text{s} \cdot 60 \cdot 0.125 \text{ m} \cdot 3.14} \text{ for } 60 \text{ s} = \text{one min}$$

$$n = \frac{30 \text{ m} \cdot 60}{\text{min} \cdot 0.125 \cdot 3.14}$$

$$n = \frac{1800}{\text{min} \cdot 0.3925}$$

$$n = 4585.99 \text{ min}^{-1}$$

Select a spindle rotational speed of 4500 min⁻¹.

Guide rule

The guide rule ensures a sound support and accurate workpiece guidance in the tool working area. The guide rule distance to the cutter arbor can be adjusted on the table surface.

The two stop rules can be adjusted to one another and, thereby, make possible an alignment to the knife cutting circle of the utilised tool.

The distance between the knife cutting circle and the edges of the stop rule must not exceed 3 mm (see also Figure 14)

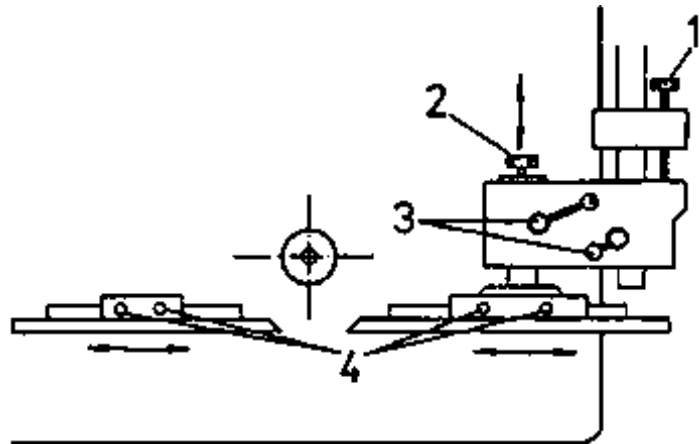

Figure 7 - Guide rule with adjusting device

1 rough setting, 2 fine setting, 3 arrest for rough and fine setting, 4 setting device for the stop rules

The guide rule features an attachment means for a chip exhaust device.

Additional stops, guidance facilities and labour safety devices can be attached to the stop faces.

For example: stop strips, stop block, spring-loaded comb and steel strip deflector. It is not permissible to utilise clamps with quick chucking mechanism or impact clamps to attach such items. Such clamps can loosen through vibrations thereby causing serious accidents.

Warming up spacers can be employed instead of the guide rule when processing workpiece faces which are not straight. Such warming up spacers are mainly used for positioning to a model. By means of milling tools the workpiece can then be aligned to the model shape. Powerwise the warming up spacer has been decoupled from the cutter arbor.

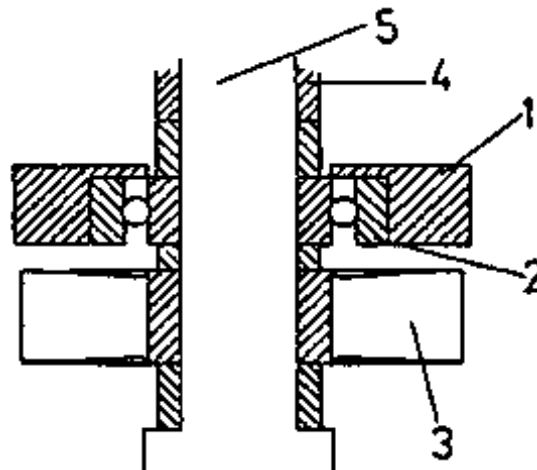

Figure 8 - Cutter arbor with tool and warming up spacer

1 warming up spacer, 2 ball bearing, 3 tool, 4 cutter arbor spacer, 5 cutter arbor

The guide rule can be replaced by a stop board for undertaking deep cutting operations (slits).

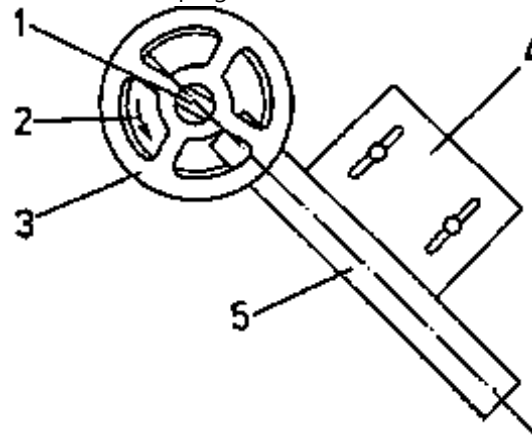

Figure 9 - Stop board mounting

1 cutter arbor, 2 tool, 3 guard spacer, 4 stop board, 5 workpiece

When processing workpieces with unfavourable dimensions job safety can be increased by means of additional devices, for instance a guidance facility for offsetting when turning out a tenon.

Why should no clamps be used to attach additional stops to the guide rule?



[Home](#) > [ar](#).[cn](#).[de](#).[en](#).[es](#).[fr](#).[id](#).[it](#).[ph](#).[po](#).[ru](#).[sw](#)

 **Operations with Shaping Machines - Course: Mechanical woodworking techniques. Trainees' handbook of lessons (Institut fr Berufliche Entwicklung, 18 p.)**

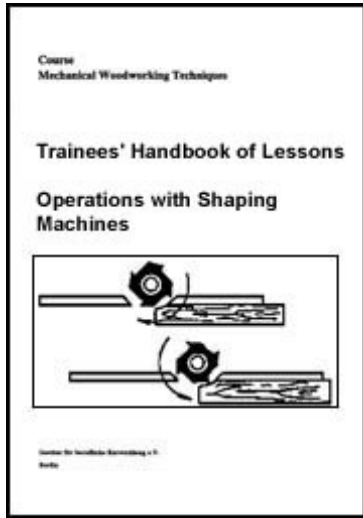

 **(introduction...)**

 **1. Purpose of Shaping Machine Operations**

 **2. Construction of a Shaping Machine**

 **3. Tools of a Shaping Machine**

 **4. Mode of Operation of a Shaping Machine**

 **5. Servicing and Looking After the Machine**

 **6. Labour Safety Measures**

3. Tools of a Shaping Machine

The shaping machine tools are subdivided into three tool categories depending on their concrete tasks and commensurate differing constructions, namely

- cylindrical cutter
- cutter heads
- milling combinations

Cylindrical cutter

The are milling tools whose basic shape resembles a disk.

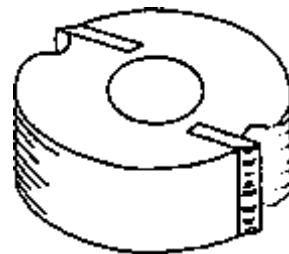

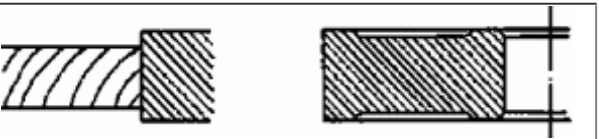



Figure 10 - Milling tool (cylindrical cutter)

The milling tools feature a central bore for attachment to the tool bearer. The tool cutters have been arranged so as to form the knife cutting circle at the tool periphery. Cylindrical cutters of tool steel are used for processing wood. These miller cutters have been hardened.

Mainly millin tools with hard metal cutters are used for processing hard materials such as chip- and fibre-boards. Such tools have a long life but can only be sharpened by means of special grinding disks.

bersicht 2

Frequently used cylindrical cutters

flat miller (cutter)	
rebating cutter	
grain cutter	
groove cutter	
quarter round cutter	

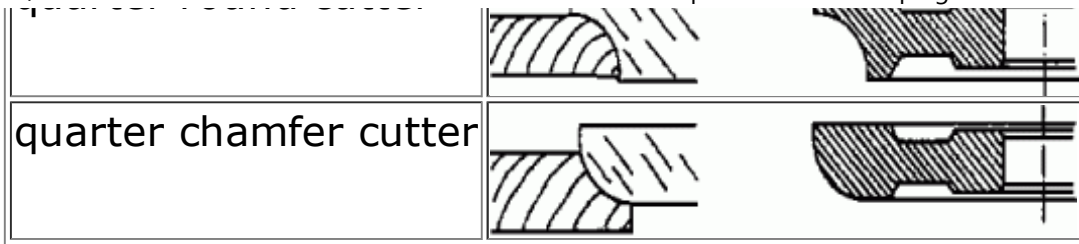

Cutter heads and milling disks

These are tools whose essential body has been constructed so as to incorporate interchangeable tool cutters.

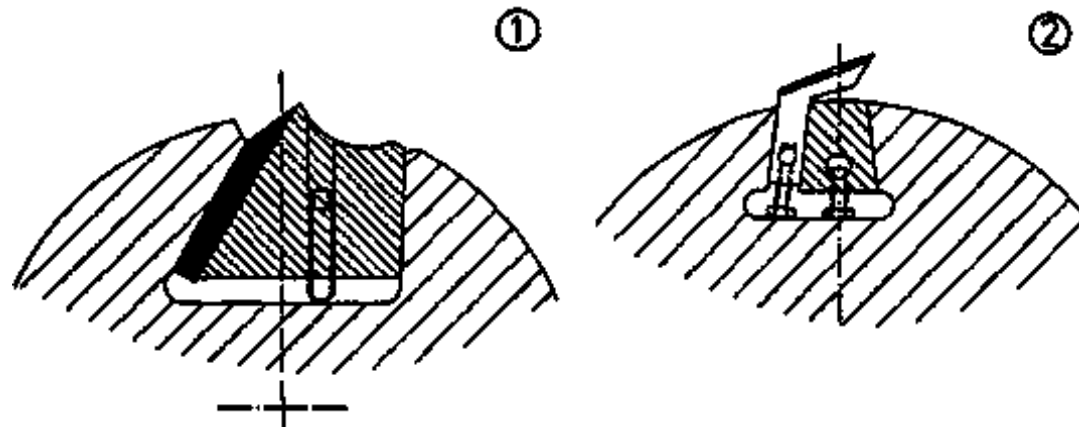

Figure 11 - Cutter heads and milling disks

- (1) gib strip tension of a cutter head,
- (2) compression taper tension of a milling disk

Multi-part milling gear is only envisaged for limited speeds. Cutter heads can only be used up to 6000 min^{-1} whilst the permissible greatest rotational speed has been imprinted onto milling disks. Exceeding these top rotational speeds can result in both tool and machine destruction through centrifugal forces.

There is furthermore a considerable risk of accidents.

Milling combinations

These are made up of various single millers. However, they can also be utilised as a set of several identical and similarly sized single millers with distance resp. chucking elements. By means of milling combinations several operations can be undertaken at the same time by the machine.

bersicht 3

Tool combinations

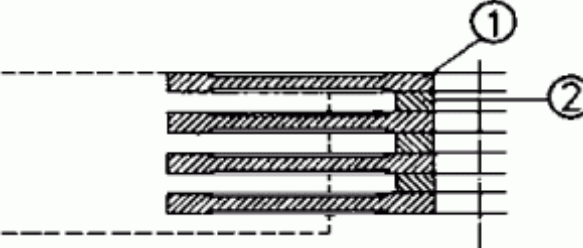
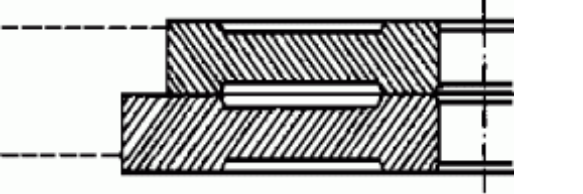
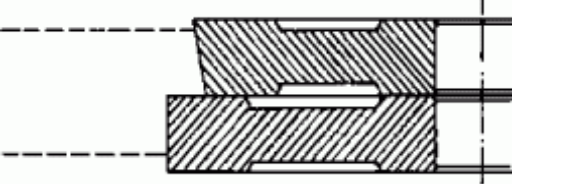
milling set for finger prongs (1) groove cutter, (2) spacer ring	
door fold milling combination	
milling combination for window wooden parts	



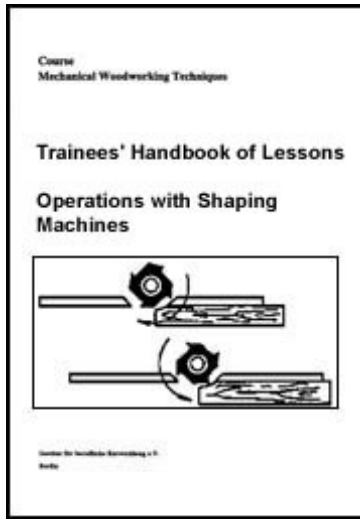

 **Operations with Shaping Machines - Course: Mechanical woodworking techniques. Trainees' handbook of lessons (Institut für Berufliche Entwicklung, 18 p.)**

 **(introduction...)**

 **1. Purpose of Shaping Machine Operations**

 **2. Construction of a Shaping Machine**

 **3. Tools of a Shaping Machine**

 **4. Mode of Operation of a Shaping Machine**

 **5. Servicing and Looking After the Machine**

 **6. Labour Safety Measures**

4. Mode of Operation of a Shaping Machine

Arc-like chipping ensues through milling with a shaping machine, moreover in a similar manner to level milling, thickness milling and circular sawing. Thereby one differentiates between climb-feed and counter-rotational cutting in line with the chipping direction vis-a-vis the direction of feed.

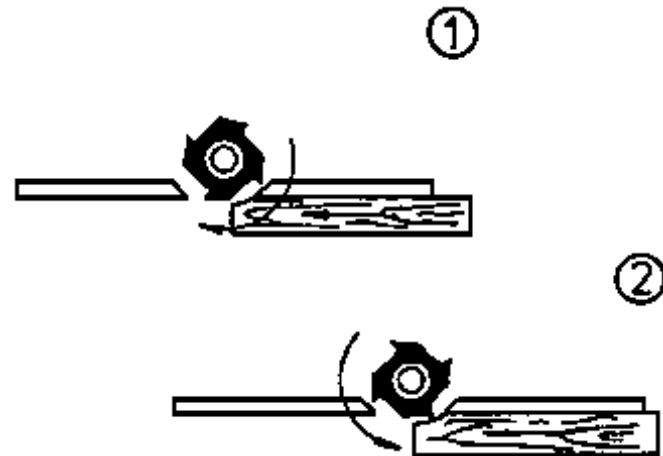

Figure 12 - Types of tension

- (1) climbfeed cutting,**
- (2) counter-rotational cutting**

Given climbfeed cutting the cutting elements along with the feed force motivate in the same direction. The processed faces are extremely clean, however given manual feed the workpiece can be pulled away from the hands.

Given manual feed, climbfeed cutting is forbidden because of the considerable accident risk!

In the case of counter-rotations cutting the cutting forces operate against the feed force. Consequently safe manual feed becomes possible. Chipped edges along the processed surfaces of slotted and milled cuts may result during counter-rotational milling. This occurs because of the unfavourable cut direction of the tool cutters vis--vis the grain direction of the work-piece.

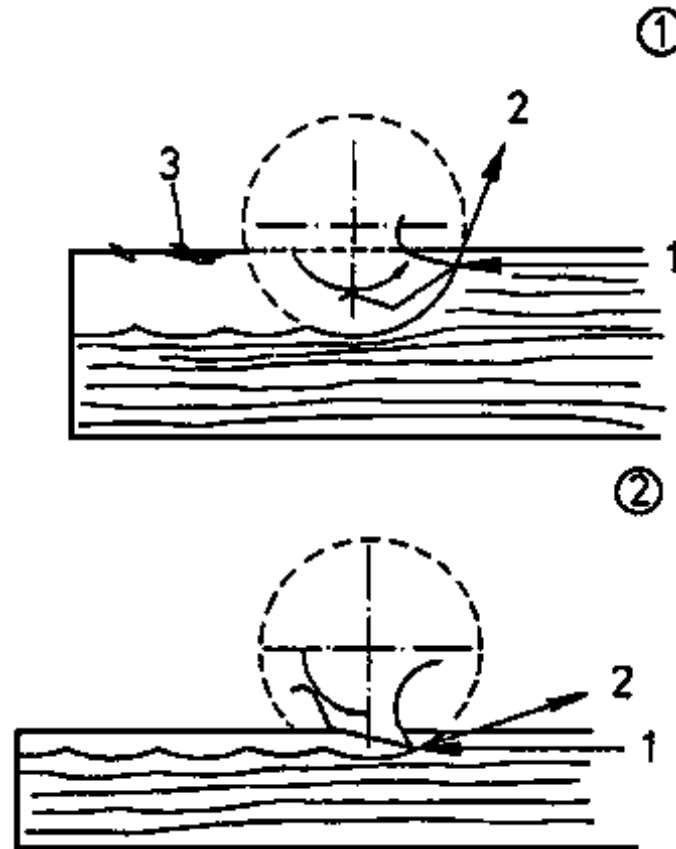

Figure 13 - Cutting force

(1) cutting force at great cutting depth

(2) cutting force at small cutting depth

1 feed force, 2 cutting force, 3 chipped edges

Why is climbfeed cutting so prone to accidents?

The tool cutters been arranged in a knife cutting circle. As cutting ensues, given an even workpiece feed, a wavy processed surface results. These waves are known as cutter blows. The nature of the waves, resp. the cutter blow depth, depends on:

- the number of tool cutters
- the tool diameter
- the rotational speed of the tool spindle
- the rate of feed of the workpiece

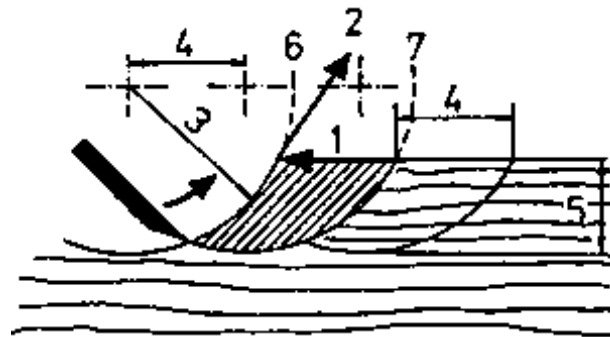

Figure 14 - Chip formation through milling

1 direction of feed, 2 cutting direction, 3 tool radius, 4 cutter feed, 5 engagement size, 6 knife cutting circle of cutting edge one, 7 knife cutting circle of cutting edge two

In order to ensure sound cutting it is necessary that all the cutters of a tool rotate through the same knife cutting circle, that is to say equidistant from the tool axis. This requirement should be especially heeded during tool maintenance. An extremely wavy or carelessly milled workpiece face can prove a hindrance during subsequent top surface processing and precondition extensive reworking.

What is the effect of using blunt tools for million operations?



[Home](#) > [ar](#).[cn](#).[de](#).[en](#).[es](#).[fr](#).[id](#).[it](#).[ph](#).[po](#).[ru](#).[sw](#)

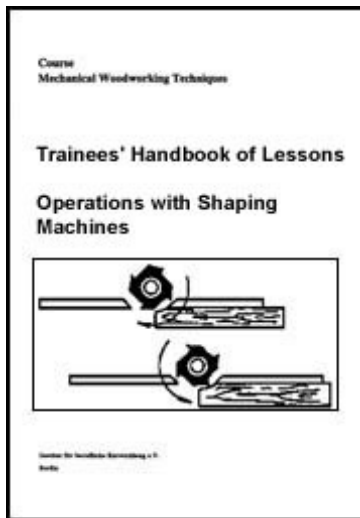

Operations with Shaping Machines - Course: Mechanical woodworking techniques. Trainees' handbook of lessons (Institut fr Berufliche Entwicklung, 18 p.)

(introduction...)

1. Purpose of Shaping Machine Operations

2. Construction of a Shaping Machine

3. Tools of a Shaping Machine

4. Mode of Operation of a Shaping Machine

5. Servicing and Looking After the Machine

6. Labour Safety Measures

5. Servicing and Looking After the Machine

Regular and proper servicing and maintenance of the machine is to a marked extent a guarantee for proper functioning and, as a result, equally for considerable job safety. Dirt should be removed daily from the table and support surfaces. The throughgoing bores and locator grooves of the machine table become soiled extremely quickly. All adjustment facilities of the guide rule and the spindle must be cleaned after machine and lightly greased at regular intervals.

The roller guide of the movable table must always be kept free from dust. Soilage can hamper the forward movement of the movable table and, thus, lead to accidents.

Every machine has an operating manual and a lubrication plan. These documents indicate:

- where and how lubrication of the machine should be undertaken, similarly also the lubrication points,**
- which lubricants should be used,**
- the necessary lubrication quantities,**
- the lubrication intervals for the various positions.**

These stipulations, which vary according to machine types, must be adhered to strictly.

The passage of air to the motor must not be impeded by fallen chips. Motor damage through overheating can result from defective air cooling of the drive machine. There is, moreover, also a great risk of fire!

The drive belt, as power-transmitting machine element, must always have the prescribed pulley tension.

The belt may loosen through wear and tear, in which case full power transmission is no longer possible. This state of affair can be discerned by a reduced spindle rotational speed as the machine is taxed. Consequently, a belt tightening facility has been positioned near to the motor attachment. Thus, the belt can be tightened, respectively relieved as it is switched to the other belt pulley pair. (This is necessary when switching to another rotational speed category).

The drive belt should not, however, be too tight. A belt which is too tight can result in:

- losses in power transmission through greater power requirements in the belt gears,
- excessive strain of the motor and spindle bearings and
- a more rapid wear of the drive belt



[Home](#) > [ar](#).[cn](#).[de](#).[en](#).[es](#).[fr](#).[id](#).[it](#).[ph](#).[po](#).[ru](#).[sw](#)

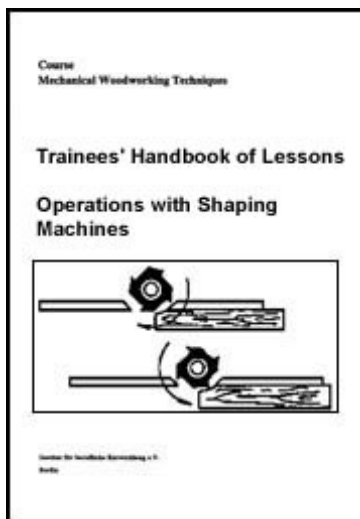

 **Operations with Shaping Machines - Course: Mechanical woodworking techniques. Trainees' handbook of lessons (Institut fr Berufliche Entwicklung, 18 p.)**

 **(*introduction...*)**

 **1. Purpose of Shaping Machine Operations**

 **2. Construction of a Shaping Machine**

 **3. Tools of a Shaping Machine**

 **4. Mode of Operation of a Shaping Machine**

 **5. Servicing and Looking After the Machine**

  **6. Labour Safety Measures**

6. Labour Safety Measures

Shaping machine operate at high rotational speeds. This denotes, apart from a greater strain on tools and the rotating machine parts, also a greater risk of accidents.

If the machine is not properly handled and the accident-prevention stipulations remain

unheeded, two serious of accidents can ensue:

- **injuries through loosening tool parts, tools or parts of the tool chucking facilities,**
- **cuts of the hands by touching rotating tools.**

The machine must not be operated without sufficient knowledge of commensurate labour safety measures!

In order to avoid industrial accidents the following labour safety hints must be strictly observed.

- **cutter arbors with top bearing tenons can only be utilised along with top bearings,**
- **the tool should be positioned as close as possible to the spacer nut on cutter arbors without top bearing tenons,**
- **the maximum rotational speed cited on multi-part and heavy tools must not be exceeded, otherwise the centrifugal forces within the tool could lead to its destruction,**
- **the tools must be exactly set and all cutters shall only operate within their commensurate knife cutting circles,**
- **tools with broken off cutters or with removed tool parts are no longer dynamically balanced. Vibrations can ensue given high rotational speeds. These in turn result in irregular blows on the workpiece and damage to the machine. Considerable accident risk.**
- **the tool bore must conform to the shaft diameter. Turned gauge rings may be used on small cylindrical cutters to compensate for a bigger tool bore on the cutter arbor shaft.,**

- **the machine has a braking device to attain spindle standstill within 10 s of switching off the motor,**
- **the guide rule must not feature any defects**
- **no screw or impact clamps should be used to attach additional devices to the machine table or guide rule as the cited clamps can easily loosen through vibrations and cause accidents,**
- **given hand feed, only counter-rotational cutting is possible!**
- **do not use any blunt tools for they exert a considerable cutting force and, then, the workpiece can only be held and guided manually with great difficulty,**
- **stop blocks must be placed alongside the stop faces of the guide rule if surface milling takes place. This prevents back movement of the workpiece.**

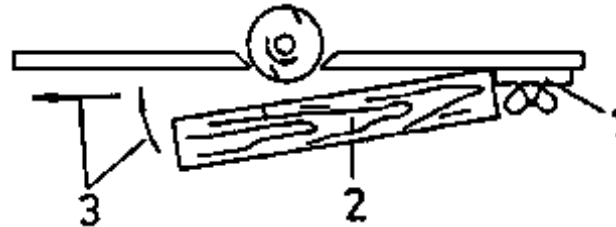

Figure 15 - Guide rule stop for surface million operations

1 stop block, 2 workpiece, 3 sequence of movement

Additional guides and blocks can, if required, be attached to the machine table. This is ensured by the throughgoing bores with internal thread in the table surface. Steel strip deflectors, protective caps and guard spacers are frequently employed to ensure that the hands do not come into contact with tools. The guard spacer should always be

greater than the tool diameter. It is envisaged for milling operations on starting-up spacers, that is to say where no guide rule can be employed. The guard spacer is of light alloy and has rounded edges. Hand contact with the guard spacer can ensue and may even be painful, however cut injuries through the tool are prevented. Where possible the guard spacer should be set up a little distance away from the tool. If the distance between machine table and tool top edge is more than 30 mm the guard spacer no longer serves its envisaged purpose. In such a case a different protective device should be employed.

The guard cap is attached to the radial arm. As applies to the guard spacer, the guard cap too is envisaged for cutting operations without a guide rule. The guard cap cannot be used in conjunction with a cutter arbor with top bearing. Generally speaking, because of the partial view hindrance, the utilisation of a guard cap makes necessary additional stops or guide facilities. A guard cap is also handy in preventing cut injuries. The guard cap should also be greater than the tool diameter.

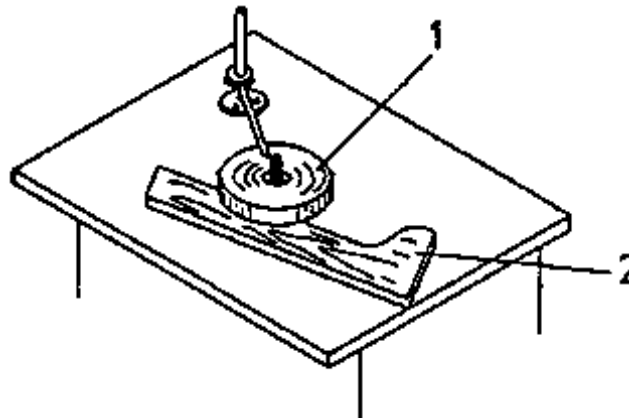

Figure 16 - Utilising the guard cap

1 guard cap, 2 workpiece

The steel strip deflector is an elastic steel belt with two holders which are used to place

the steel strip deflector into two bores of the top narrow faces of the guide rule. The height is set so that its lower edge is not more than 8 mm away from the workpiece top edge. The elastic steel belt, given a favourable selection of bores in the stop rule, permits an arc-like shielding of the tool working area.

Pressure combs can be attached to the machine table and guide rule for improving tool handling capacity and preventing a backwards movement of the workpiece. A pressure comb ensures a partial covering of the tool.

Pressure combs are not standard machine equipment and must be made in the workshop.

What is the function of the “pressure comb” as an aid and labour safety facility?

Why is only counter-rotational milling permissible for manual feed milling operations?

Cleanliness and proper order are essential preconditions for accident-free operations!

