

Attic Completion Work – Course: Timberwork techniques. Instruction examples for practical vocational training

Table of Contents

<u>Attic Completion Work – Course: Timberwork techniques. Instruction examples for practical vocational training</u>	1
<u>Preliminary Remarks</u>	1
<u>Instruction Example 2.1.: Making Openings for Roof Superstructures in Existing Roofing</u>	1
<u>Instruction Example 2.2.: Making a Rafter Trimming</u>	4
<u>Instruction Example 2.3.: Making the Opening for the Roof Window to be Built in</u>	8
<u>Instruction Example 2.4.: Joining of the Parapet Transom</u>	11
<u>Instruction Example 2.5.: Joining of the Window Posts</u>	14
<u>Instruction Example 2.6.: Joining of the Lintel Transom</u>	17
<u>Instruction Example 2.7.: Joining of the String Transoms and Roof Rafters</u>	20

Attic Completion Work – Course: Timberwork techniques. Instruction examples for practical vocational training

Institut für berufliche Entwicklung e.V.
Berlin

Original title:

Lehrbeispiele für die berufspraktische Ausbildung
"Herstellen von Dachausbauten"

Author: Rolf Becher

First Edition © IBE

Institut für berufliche Entwicklung e.V.
Parkstraße 21–23
13187 Berlin

Order No.: 93–33–3602/2

Preliminary Remarks

The present booklet contains 7 selected instruction examples to show the manual skills a carpenter must have and logical considerations he must make to meet the requirements of this trade.

The individual instruction examples have been selected so that they can be separately practised and carried out.

The Instruction Examples 2.3. to 2.7. are successively based on each other with the whole complex representing the entire technological flow for joining an upright window roofed with lean-to dormer.

The working drawings show the cross sections and lengths of timbers to be used by the trainees for the relevant steps of work.

Instruction Example 2.7. clearly explains how to calculate the real timber lengths and the recess sizes in the event of different roof pitches.

The logical sequence of the necessary steps of work is given in each instruction example and shown in the respective working drawings.

The hand tools, measuring and testing means, auxiliary accessories, as well as previous knowledge required are also mentioned.

Instruction Example 2.1.: Making Openings for Roof Superstructures in Existing Roofing

This instruction example explains how to saw out the openings for the roof window to be built in the existing roofing.

Constructional details

- Gable roof as purlin roof with triple upright truss.
- Eaves angle: 45 degrees.
- Rafter distance: 800 mm.
- Roofing consisting of 24 mm thick boards with slating.

– Scaffolding is available at the facade.

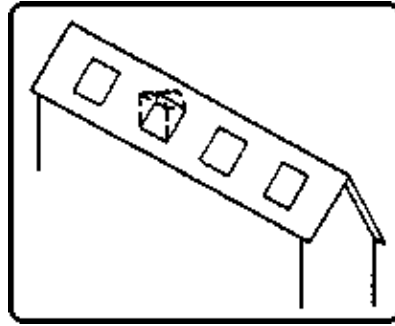

Hand tools

Hammer, hand saw, compass saw, pad saw, bit brace, insert bit of 20 mm diameter, carpenter's pincers

Measuring and testing means

Folding rule

Auxiliary accessories

Marking pencil, roofers' scaffolding, facade scaffolding, safety belt with catch rope

Necessary previous knowledge

Measuring, scribing, boring, sawing, functions of angles, reading of tabular values, reading of drawings

Explanations to the working drawing

1 = area where the roofing is to be removed

Sequence of operations

1. Determine the sizes for the openings to be saw out and draw a hand sketch.
2. Check facade scaffolding for completeness and stability.
3. Measure-in and scribe on the existing roof face the lower horizontal limitation for removing the roof slates.
4. Measure-in and scribe the lateral limitation of the roof window opening.
5. Remove the roof slates above the lower limitation line.
6. Mount the roofer's scaffolding on the slate roof surface.
7. Measure-in and scribe the upper horizontal limitation for removing the roof slates.

Comments

- See working drawing!
- Check covering of uprights for support.
Check anchoring and bracing.
- Take the sizes from the hand sketch. Scribe with the marking pencil at one window only, starting from the centre of the roof window.
Draw the scribed line at both sides beyond the trimmer rafters.
- Measure from the centre of the roof window. Start scribing about 100 mm below the lower horizontal limitation and continue until about 300 mm upwards.
- Remove the roof slates so that they can be used again.
The outer edge of the trimmer rafter must be free of slates.
- Use scaffolding trestles with brushes.
- Work on the roofer's scaffolding with safety belt only.
Fix catch rope to ladder hooks. Draw scribed line at both sides beyond the trimmer rafters (see working drawing for sizes).

- | | |
|--|---|
| 8. Remove the slates up to the upper horizontal limitation of the opening. | Laterally the opening is limited by the trimmer rafters. |
| 9. Produce a borehole at the inside of the trimmer rafters below the upper limitation line. | Use a 20 mm diameter bit to enable the compass saw to start. If possible, bore near a roof board joint. |
| 10. Saw out the first board with the compass saw. | Guide the compass saw blade along the inside face of the trimmer rafter.
Don't let the sawn-out board fall into the attic – danger of accidents! |
| 11. Saw out the roof boards up to the lower horizontal limitation using a pad saw and then a hand saw. | Guide the saw blade along the inside face of the trimmer rafter. |
| 12. Remove the roofers' scaffolding. | |
| 13. Measure-in and scribe the limitation for the next opening. | Measure from the centre of the first roof window.
Repeat steps 3. through 12. |

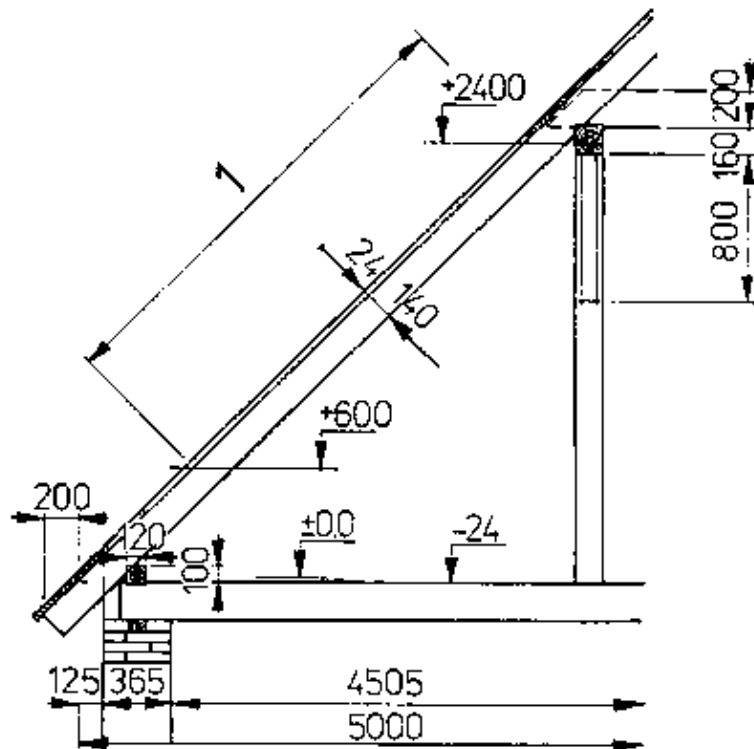
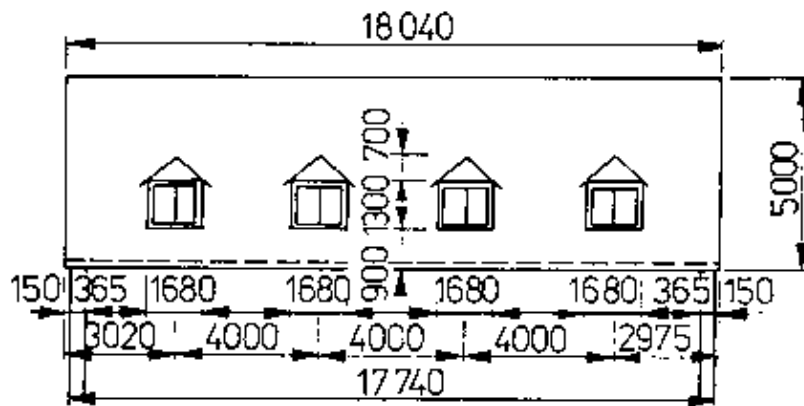

				2.1.
IBE	Roof Superstructures			3602

Roof Superstructures

Instruction Example 2.2.: Making a Rafter Trimming

This example teaches how to saw out the rafters of the main roof and build in the parapet trimmings in the area of the existing openings for upright roof windows to be built in, in order to make use of the attic.

Constructional details

- Gable roof as purlin roof.
- Eaves angle: 45 degrees.
- Rafter distance: 800 mm.
- Parapet trimming to be joined with steel squares and hexagon–head wood screws. Tail rafter to be joined with mortise–and–tenon joint.
- Steel squares and hexagon–head wood screws to be supplied.

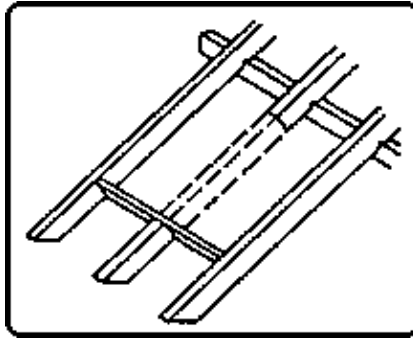

Hand tools

Hammer, hatchet, bit brace, insert bits of 6.2 mm and 3 mm, wrench with 10 mm opening, mortise chisel 24 mm, planing chisel 35 mm, beating wood

Measuring and testing means

Folding rule, engineer's square, water–level

Auxiliary accessories

Pencil, trestles, batten of 2200 mm length, cover strap of 700 mm length, 40 mm thickness and 120 mm width, cover strap of 700 mm length, 24 mm thickness and 120 mm width, 3.1/70 nails, 10/40 hexagon–head wood screws of diameter 6, clamp iron

Necessary previous knowledge

Measuring, plumbing, scribing, boring, mortising, planing (smoothing), reading of drawings

Explanations to the working drawing

The identification figures allocated to the arrows correspond to the numbers of the working steps in the working drawing.

Sequence of operations

1. Store the tools, auxiliary accessories and parapet trimmings in the attic.
2. Erect the trestles and put on the rafter trimmings.
3. Check the parapet trimmings, decide on the joining side and mark with marking–out mark.
4. Measure the clearance between the trimmer rafters.

Comments

- Do not store them in the immediate working area – danger of accidents!
- Ensure stability of the trestles!
- The joining side is the surface of the roof rafters. Use the slight camber of the timber as joining side!

- | | |
|--|---|
| 5. Measure the clearance between the trimmer rafters and tail rafters to be produced. | |
| 6. Scribe section at left end of parapet trimming and mark with marking-out mark. | Use a sharp pencil and the engineer's square. |
| 7. Measure-in, scribe and mark clearance between trimmer rafters, starting from the scribed section line towards the right. | Place folding rule in parallel with parapet trimming and let folding rule tongues engage properly. |
| 8. Measure-in and scribe measured size between trimmer rafters and tail rafters, starting from the left scribed section line towards the right. | Scribe a thin line and place the engineer's square! |
| 9. Measure-in and scribe mortise length from scribed line 8. towards the right. | |
| 10. Measure-in and scribe mortise width. | Measure from the joining side! |
| 11. Transfer the scribed section lines at both ends of parapet transom onto all timber faces. | The scribed section lines must be congruent! |
| 12. Place parapet transom on trestles so that face "1" is on top and then make the mortise. | Ensure firm support on the trestles!
Select the trestle distance so as to prevent tilting-up of the parapet transom during mortising, otherwise there is the danger of accidents! |
| 13. Saw parapet trimming to length. | Saw exactly along the scribed pencil line! |
| 14. Place steel square on both sawn ends of parapet transom, scribe borehole of square and take off square. | Scribe one side first and then the other one.
Place water-level for alignment on cross-grain end of parapet transom and locate steel square flush.
Place water-level with flat side not perpendicular.
When placing water-level ensure complete contact! |
| 15. Pre-bore holes of 3 mm diameter for screwing in the hexagon-head wood screws. | Place bit on centre of scribed holes! |
| 16. Put on steel square, place hexagon-head wood screw and screw it in by wrench. | Do not overturn the hexagon-head wood screw when tightening it, otherwise the steel square will not fit snugly.
Place water-level for alignment of steel square before finally tightening the screws. |
| 17. Place folding rule perpendicularly on tail rafter to be produced and scribe 600 mm size. | Scribe-mark exactly on bottom side of rafter! |
| 18. Scribe section. | Use engineer's square and scribe thin line! |
| 19. Scribe tenon length and mark with marking-out mark. | Tenon length – engineer's square width, measure towards roof ridge! |
| 20. Measure-in and scribe tenon thickness. | Measure from surface of rafter downwards! |
| 21. Nail cleat for stiffening of rafter to bottom side. | Saw off cleat of approx. 200 mm length from cover strap (24 mm thick)!
Nail cleat so as to avoid interference when working the tenon! Drive in three 3.1/70 nails! |
| 22. Determine and scribe inclination of cover strap (50 mm thick) for stiffening of rafter and tack cover strap (24 mm thick) with its end face. | Inclination of about 55 degrees is equal to a ratio of 1 (horizontal) : 1.33 (vertical).
Do not nail but just tack the cover strap (24 mm thick)! |
| 23. Place cover strap for stiffening, scribe face and length and prepare cover strap. | |

24. Place the prepared cover strap (50 mm thick) under the rafter with one end to contact the cleat and the faced end on the floor. Loosen the tacked cover strap (24 mm thick), shift it to the faced end, drive it towards the eaves angle and nail it on.
25. Nail 24 mm cover strap firmly.
26. Place the 2200 mm batten perpendicularly on the floor contacting the rafter on top. Plumb the batten and scribe the height line on the rafter.
27. Continue the height–line scribing horizontally up to the lower edge of the rafter.
28. Scribe the section line and mark it with marking–out mark.
29. Saw out the rafter.
30. Produce tenon on tail rafter.
31. Plug on parapet trimming with mortise on tenon of tail rafter, hammer and secure it against turning off.
32. Align parapet trimming and bore holes through boreholes in screwed–on steel square into one of the two trimmer rafters for screwing–in of hexagon–head wood screws.
33. Place hexagon–head wood screws and screw them in by means of wrench.
34. Bore holes in the other trimmer rafter, place hexagon–head wood screws and screw them in by means of wrench.
35. Complete stiffening of roof rafter, nail cover straps completely, clear working place and prepare for next roof superstructure, place hexagon–head wood screws and screw them in by means of wrench.
- Do not pull out the tack–nail off the cover strap!
Put one foot on the cover strap when driving so that it cannot spring back!
Do not hammer over the cover strap when driving –danger of injury!
- Drive in three 3.1 mm diameter nails, 70 mm shank length (nails 3.1/70).
- Use a water–level!
- Use the engineer's square for scribing!
Transfer the section line to all four faces of the rafter!
- Saw through on top at first strictly following the scribed line! When the lower end is being sawn through, it is absolutely necessary that a second worker secures the rafter piece to be sawn out against turning off, otherwise there is a great danger of accidents.
- Secure by means of clamp iron. Do not fully drive in clamp iron jaws into the wood to avoid splitting of wood!
- Use 3 mm diameter bits!
- Do not overturn hexagon–head wood screws when tightening
- Before boring, press parapet trimming again towards eaves angle and keep pressing when boring.
- Repeat steps 2. through 34!

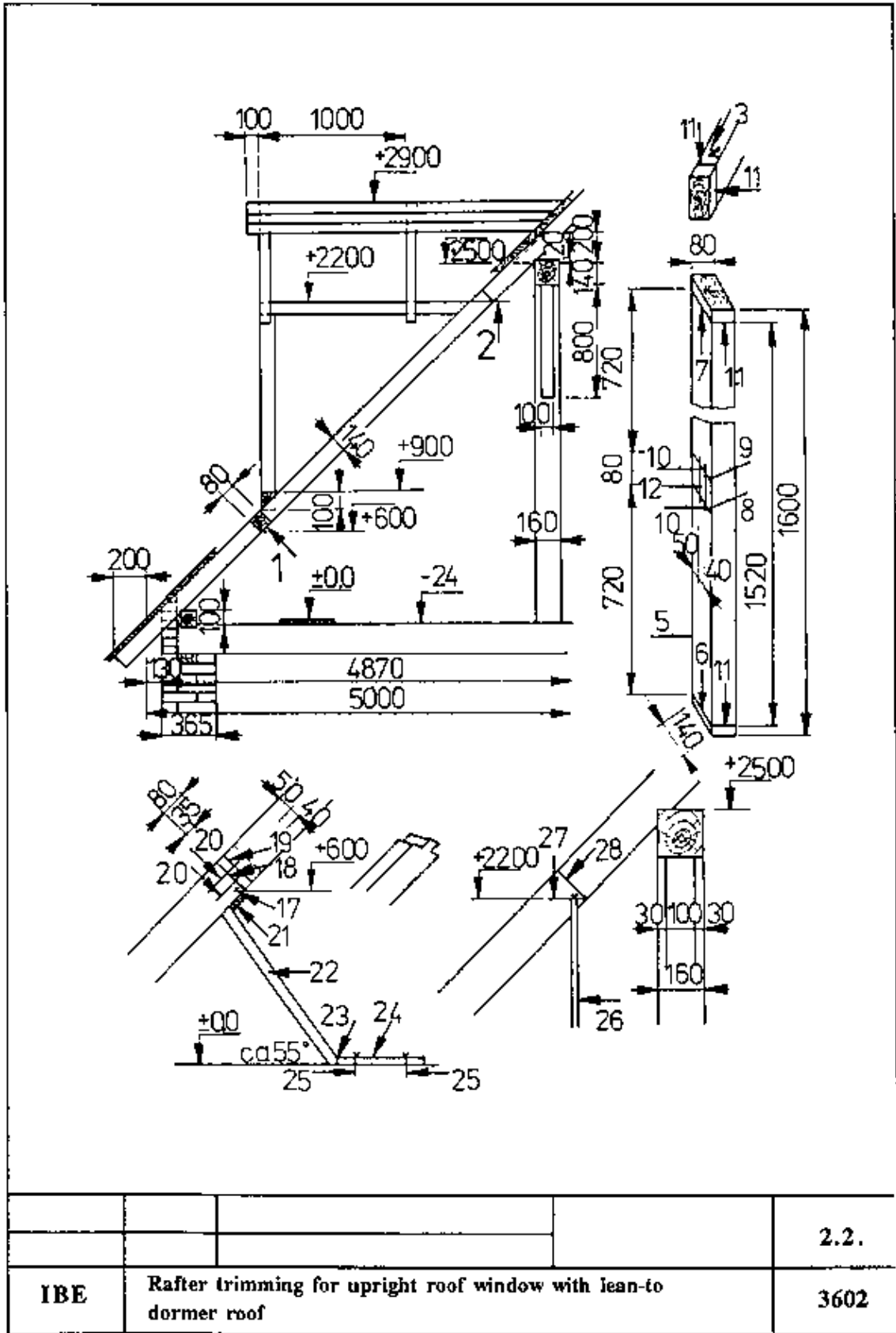

Rafter trimming for upright roof window with lean-to dormer roof

Instruction Example 2.3.: Making the Opening for the Roof Window to be Built in

This instruction example teaches how to make the opening in the existing roofing for the upright roof window with lean-to dormer roof to be built in.

Constructional details

- Gable roof as valley–beam (collar–beam) roof.
- Eaves angle: 45 degrees.
- Rafter distance: 820 mm.
- Upper edge of head rail: 2200 mm.
- Roofing consisting of 24 mm thick roof boards and two layers of roofing felt.
- Scaffolding is available at the facade.

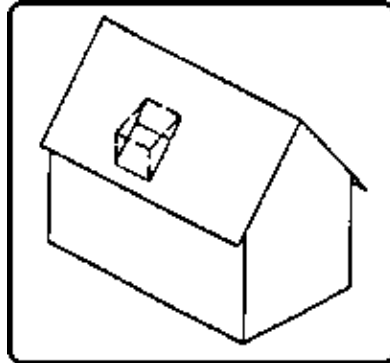

Hand tools

Hammer, hand saw, compass saw, pad saw, bit brace, insert bit of 20 mm diameter, carpenter's pincers, knife

Measuring and testing means

Folding rule, water–level

Auxiliary accessories

Marking pencil, battens of about 800 mm and 2300 mm length, straight–edge, safety belt with catch rope, 3.1/70 nails, ladder battens – 10 pcs.

Necessary previous knowledge

Measuring, plumbing, scribing, boring, sawing, reading of drawings

Sequence of operations

1. Make available the necessary tools and materials.
2. Saw to length short batten to 750 mm and long batten to 2200 mm.
3. Find out in the attic the rafters where to build in the roof superstructure.
4. Place short batten perpendicularly on the floor leaning to the rafter on top and shift it towards the eaves angle.
5. Scribe marking–out line on roof boarding.
6. Scribe height line on opposite rafter.
7. Place nail on scribed line and drive it through the roofing from the inside to the outside.

Comments

- Secure tools and materials against falling down from the roof.
- Saw the two battens at right angles!
- Take size from the drawing!
- Use water–level! Place water–level to ensure perpendicularity when shifting the batten towards the eaves angle! Shift batten up to the roof bearding!
- Repeat steps 4. and 5!
- Make sure that the nail is long enough to penetrate at the outside roofing!
Place nail as close at the rafter as possible.
Repeat this at the neighbouring rafter.
- Similarly to steps 4. through 7.

- | | |
|--|--|
| 8. Place long batten perpendicularly on the floor and scribe upper limitation of the opening. | |
| 9. Check facade scaffolding including safety measures for completeness and stability. | Check anchoring or bracing and upright covering support. Check safety fence, particularly for foot board! |
| 10. Locate straight-edge at driven-through nails and scribe lower limitation of opening. | Locate the straight-edge so as to scribe the limitation of the opening greater by the straightedge width. Use marking pencil. |
| 11. Locate straight-edge for lateral limitation at the driven-through nails and drive in tack-nail. | Drive in tack-nail to prevent the straight-edge from slipping off! Do not drive in the nail completely because it has to be pulled out again! |
| 12. Nail ladder battens onto roofing at a distance of about 500 mm. | Nail on ladder battens outside the opening to be made at a distance of about 100 mm from the tacked straight-edge!
Nail length should equal at least 2 times the thickness of the ladder batten!
Use the safety belt and fix the catch rope to the ladder hooks! |
| 13. Scribe lateral limitation of the opening. | Scribe greater by the straight-edge width! |
| 14. Loosen and remove straight-edge. | Pull out nail with hammer pane!
Pull out nail just as much as to permit the straightedge to be removed! |
| 15. Locate straight-edge at opposite side and scribe lateral limitation. | Proceed similarly to steps 11. through 14. |
| 16. Drive nails for opening limitation back. | Just drive back nails, do not pull them out! |
| 17. Loosen and remove roofing felt between the scribed marking-out lines. | Guide the knife along the scribed lines and cut the roofing felt through!
Pull out with pincers any felt nails left in the roof boarding!
Do not throw the removed roofing felt from the scaffolding! |
| 18. Bore a hole at the inside of the roof rafter below the upper limitation nail. | Use 20 mm diameter bit to enable the compass saw to start!
Bore close to a roof board joint, if possible!
Do not bore into the driven-in nail! Use the safety belt! |
| 19. Bore a hole at the neighbouring roof rafter. | Repeat step 18.! |
| 20. Saw out the first board using the compass saw. | Guide compass saw blade along the inside face of the rafter!
Do not let the sawn-out board fall into the attic! |
| 21. Saw out the roof boards up to the lower horizontal limitation of the opening using a pad saw and hand saw. | Guide the saw blade along the inside face of the rafter!
Do not let the boards fall into the attic! |
| 22. Clear the working place. | Store the sawn-out boards in the attic. Pull out driven-in or left roofing felt nails!
Remove the cut out roofing felt from the scaffolding but do not throw it off!
Do not remove the ladder battens, they can be used for building in the upright roof window! |

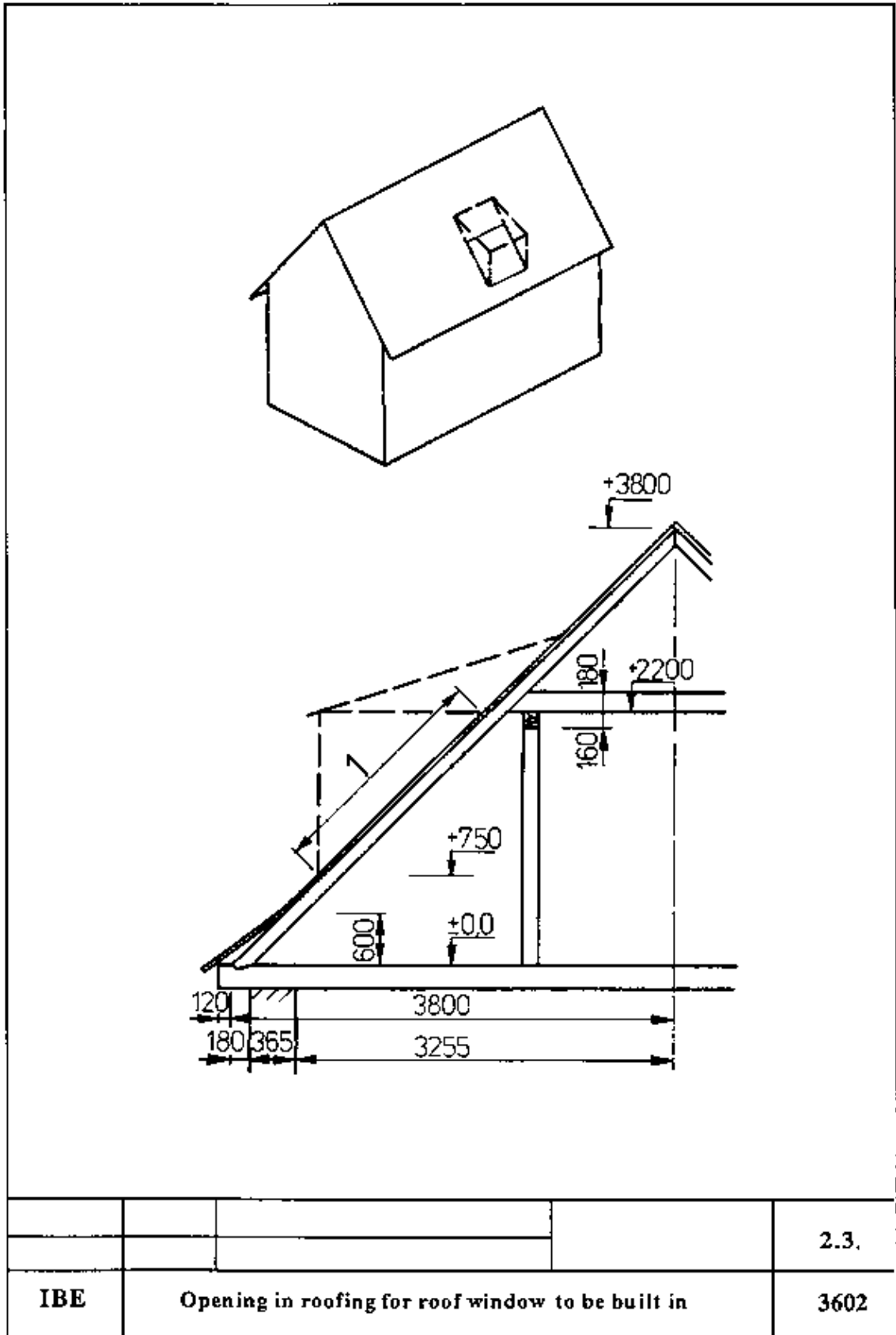

Opening in roof window to be built in

Instruction Example 2.4.: Joining of the Parapet Transom

This instruction example teaches how to join the parapet transom for an upright roof window with lean-to dormer roof.

Constructional details

- The opening in the roofing has already been made.
- Window posts are to be joined with a corner tenon.
- Cross sections of timbers are shown in the workshop drawing on page 7.
- Parapet transom is just cut to the length of 950 mm.

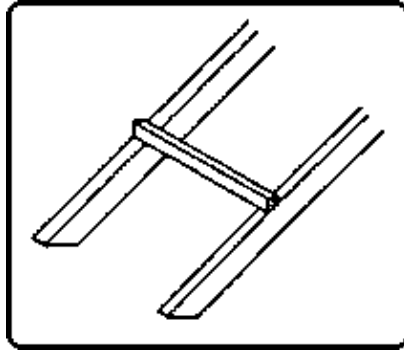

Hand tools

Hammer, engineer's square

Measuring and testing means

Folding rule

Auxiliary accessories

Trestles (one ell), pencil, marking gauge, workshop drawing

Necessary previous knowledge

Measuring, scribing, angling, use of marking-out marks, reading of drawings

Explanations to the working drawing

(D sectional view A–A, (2) upright roof window – front view.

The figures 1 to 12 represent the steps as per sequence of operations.

Sequence of operations

1. Manufacture a marking gauge.
2. Erect the trestles and prepare the working place.
3. Put the parapet transom on the trestles, decide on the joining side and mark it.
4. Scribe the section line at the left end of the parapet transom and mark with marking-out mark.
5. Measure-in and scribe parapet transom length, starting from the section line and measuring to the right, mark with marking-out mark.

Comments

- See working drawing point VII.
Make sure that the recess sizes (35 mm, 70 mm) are sawn out at right angles!
- Ensure firm standing and stability of the trestles!
Store timbers, which are not required, outside the working area!
- Joining side III shall have a flat face!
If the timber is slightly cambered, take that camber on top (VI)!
- Go only as far to the right as to permit a right-angle section to be produced!
Use engineer's square and scribe a thin line!
- Use engineer's square and scribe a thin line!

- | | |
|--|---|
| 6. Measure–in and scribe at left and right section the window post width towards the centre. | Use engineer's square. |
| 7. Measure–in and scribe the comer tenon width from the two scribed lines towards the two ends of the parapet transom. | Use engineer's square and don't scribe over the total timber width! |
| 8. Scribe the tenon thickness. | Use marking gauge and scribe with sharp pencil exactly at marking gauge end face (VIII)!
Do not cant marking gauge when scribing! |
| 9. Scribe section line on all four sides at the two ends of the parapet transom and mark with marking–out mark. | Use engineer's square. The scribed section lines of all timber sides must be congruent!
If section lines are not congruent, find out the reasons:
– Engineer's square not correctly placed.
– Faulty square. |
| 10. Scribe roof rafter inclination of main roof and mark with marking–out mark. | Place square legs for scribing and exactly scribe the diagonal. |
| 11. Measure–in, scribe and mark with marking–out mark the rafter width of the main roof on the side (V) opposite the joining side. | Use engineer's square and place it exactly! |
| 12. Transfer rafter width line to bottom side (IV) and mark with marking–out mark. | Place engineer's square exactly. |
| 13. Work parapet transom accordingly, take it off the trestles and store it outside the working area. | |

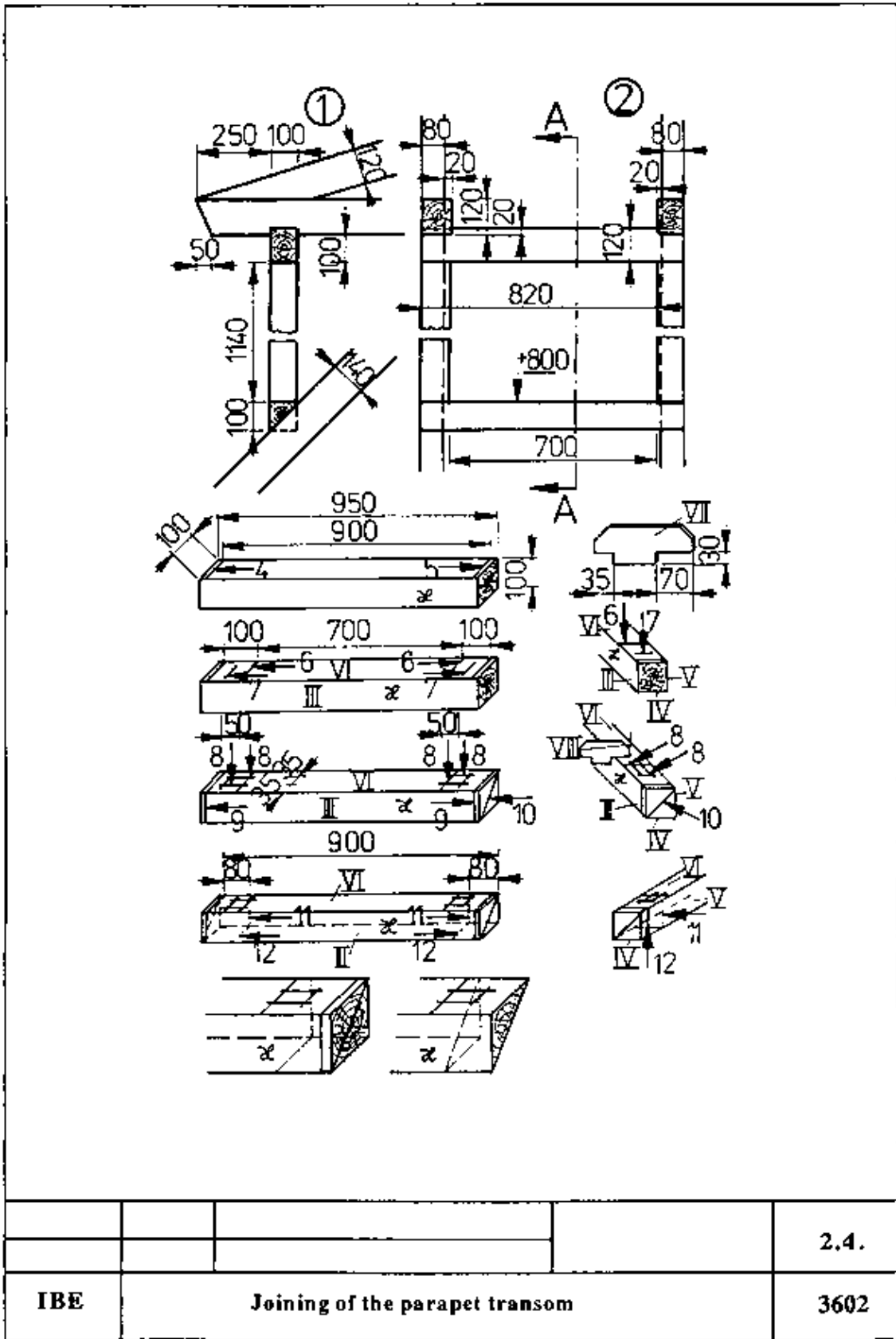

Joining of the parapet transom

Instruction Example 2.5.: Joining of the Window Posts

This instruction example teaches how to join the window posts for an upright roof window with lean-to dormer roof.

Constructional details

- The opening in the roofing has already been made.
- Window posts are to be joined with corner tenons.
- Cross sections of timbers are shown in the workshop drawing on page 7.
- Window posts are cut to a length of 1250 mm.

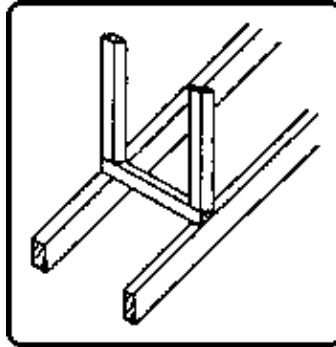

Hand tools

Hammer, engineer's square

Measuring and testing means

Folding rule

Auxiliary accessories

Trestles (one ell), pencil, marking gauge, workshop drawing

Necessary previous knowledge

Measuring, scribing, angling, use of marking-out marks, reading of drawings

Explanations to the working drawing

The figures 2 to 14 represent the steps as per sequence of operations

Sequence of operations

1. Prepare the working place, erect the trestles with the correct distance.
2. Inspect the window posts, decide on the joining side and mark with marking-out mark.
3. Put the window posts closely together on the trestles.
4. Scribe section lines at left ends of window posts and mark with marking-out mark.
5. Angle the section line at both joining sides, scribe and mark-out.
6. Measure-in and scribe window post length, starting from the section line and measuring to the right, and

Comments

- Check the trestles for firm standing and stability!
- Joining side "I" shall have an even face!
Any slight camber is to be used as outside face of the window post and to be marked with "II".
- Put them so that the face marked with "II" is visible from above!
Place the joining sides so that they remain visible (see V)!
Hammer with gentle hammer blows so that the left ends of the timbers are about flush!
- Go only as far to the right as to permit a right-angle section to be produced!
- Use engineer's square!
- Window post length = clear window height plus two tenon lengths!

mark with the marking-out mark.

Use engineer's square and place it exactly!
Clear window height is shown in Instruction
Example 2.4!

7. Angle the section line at right ends of window posts at the joining sides, scribe and mark-out.

Use engineer's square!

8. Measure-in and scribe the corner tenon length at both section ends on timber face "II", measuring towards the centre.

Scribed line must be in parallel with scribed line of steps 4. and 6. above!

9. Angle and scribe corner tenon length at the two joining sides.

Place engineer's square exactly and scribe thin line!

10. Move the window posts apart because now each of them is to be separately scribed.

Select the distance so that scribing between the timber faces marked with "III" is possible without hindrance!

11. Scribe the corner tenon thickness at the left ends of the window posts.

Place sharp pencil exactly at marking gauge end face and scribe from the joining side! Do not cant the marking gauge when scribing!

12. Scribe the corner tenon thickness at the right ends of the window posts.

See step 11. above!

13. Measure-in and scribe corner tenon width.

Scribed line must be in parallel with timber face "II"!

14. Mark wood to be sawn out at all four corner tenons.

Scribe crossing diagonal lines!

15. Angle the section lines at both ends of the window posts onto the timber faces "III" and "IV", scribe and mark with marking-out mark.

16. Work the window posts.

17. Take the worked window posts off the trestles and store them outside the working area.

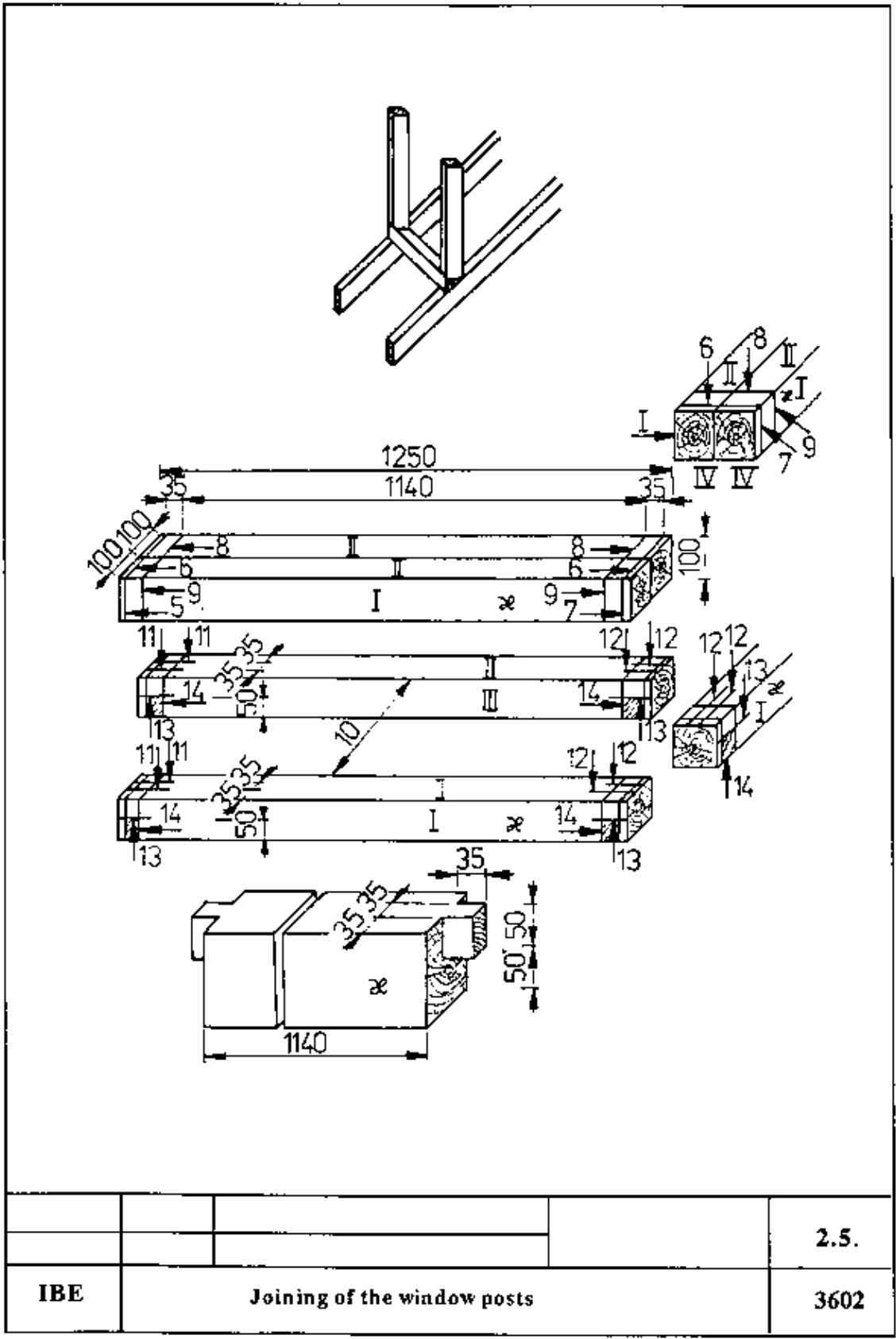

Joining of the window post

Instruction Example 2.6.: Joining of the Lintel Transom

This instruction example teaches how to join the lintel transom for an upright roof window with lean-to dormer roof.

Constructional details

- The opening in the roofing has already been made.
- Window posts are to be joined with a corner tenon.
- Cross sections of timbers are shown in the workshop drawing on page 7.
- Lintel transom is cut to a length of 950 mm.

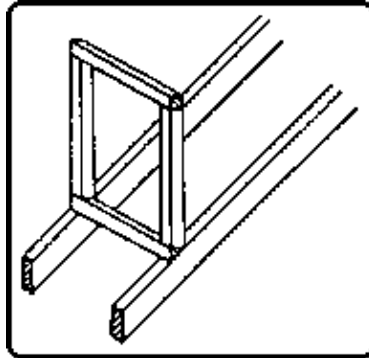

Hand tools

Hammer

Measuring and testing means

Folding rule

Auxiliary accessories

Trestles (one ell), pencil, marking gauge, workshop drawing, engineer's square

Necessary previous knowledge

Measuring, scribing, angling, use of marking-out marks, reading of drawings

Explanations to the working drawing

The figures 2 to 7 represent the steps as per sequence of operations.

I joining side, II bottom side of lintel transom. III side opposite to joining side, IV top side of lintel transom

Sequence of operations

1. Prepare the working place, erect the trestles with the correct distance.

2. Put lintel transom on trestles, decide on joining side and mark with marking-out mark.

3. Scribe section line at left end of lintel transom, angle onto all four faces and mark with marking-out mark.

4. Measure-in length of lintel transom from section line towards the right, angle onto all four faces and mark with marking-out mark.

5. Measure-in and scribe window post width, starting from left and right section line and measuring towards the centre.

Comments

Check the trestles for firm standing and stability!
Store timbers to be joined, which are not used now, outside the working area.

Joining side "I" shall have an even face!
Any slight camber is to be used as top side of the lintel transom and to be marked with "IV"!

Go only as far to the right as to permit a right-angle section to be produced! Use engineer's square for scribing! Place lintel transom so that face marked "II" is on top again!

Place folding rule exactly and in parallel! Use engineer's square for scribing!

For window post widths see Instruction Example 2.4.!

6. Measure-in and scribe the corner tenon width from the two scribed lines towards the ends of the lintel transom.

7. Scribe corner tenon.

8. Chisel out the mortise, cut lintel transom to length, take it off the trestles and store it outside the working area.

Scribed line must be in parallel with scribed line of step 5. above!

Use marking gauge and place sharp pencil exactly at marking gauge end face! Do not cant marking gauge when scribing!

Pass marking gauge along joining side for the two scribed lines!

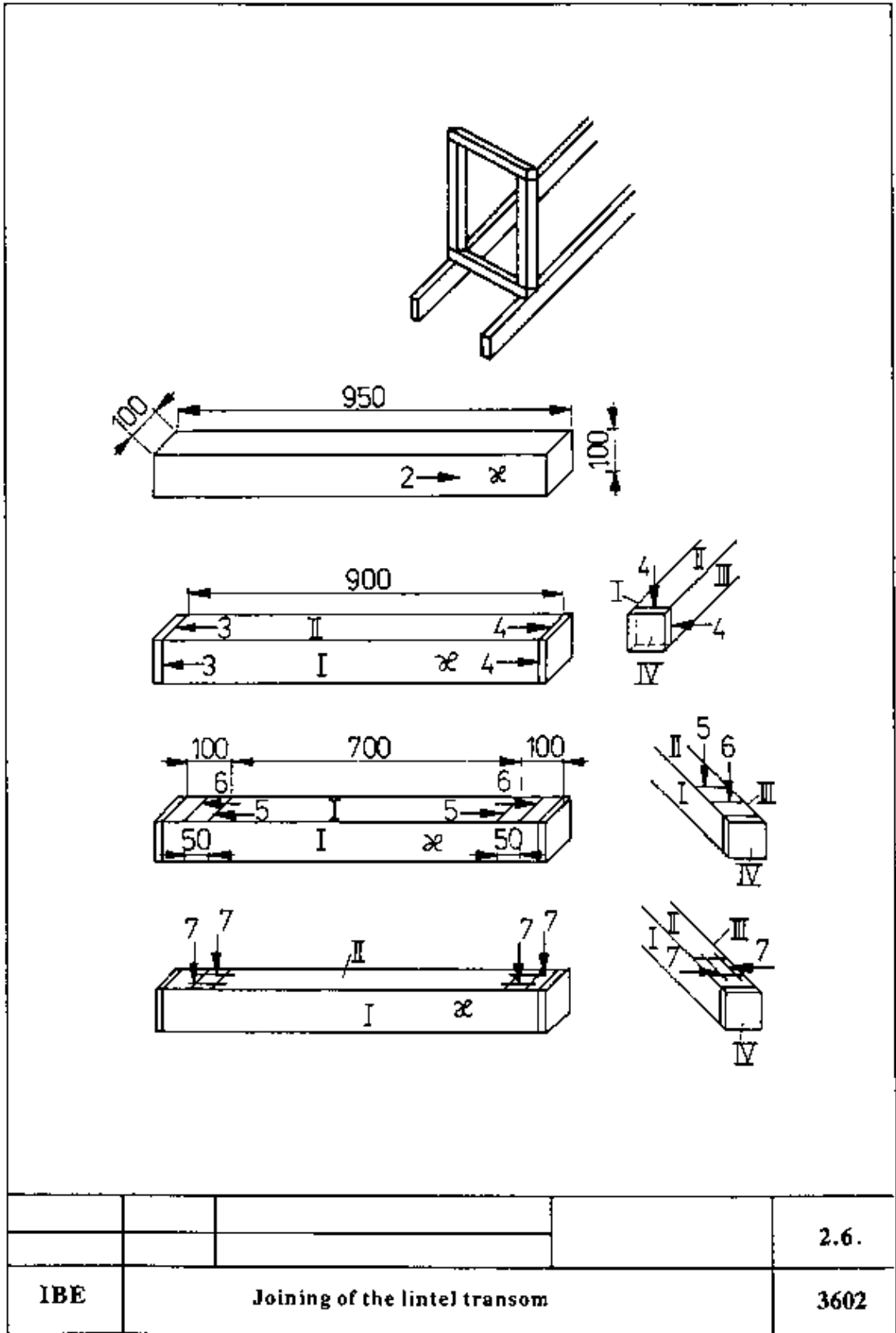

Joining of the lintel transom

Instruction Example 2.7.: Joining of the String Transoms and Roof Rafters

This instruction example teaches how to join the string transoms and roof rafters for an upright roof window with lean-to dormer roof to be built in.

Constructional details

- String transoms are to be supported on main roof rafters and cogged in the lintel transom.
- Roof rafters are to be supported on rafters of the main roof and on the string transoms.
- Cross sections of timbers are shown in the working drawing of Instruction Example 2.4.
- String transoms are cut to a length of 1750 mm and roof rafters are cut to a length of 2750 mm.

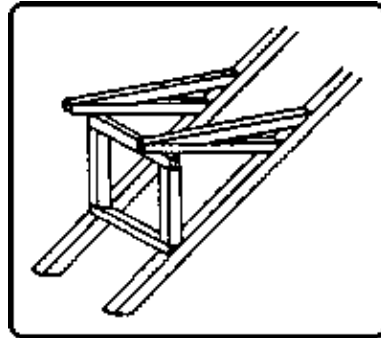

Hand tools

Hammer

Measuring and testing means

Folding rule

Auxiliary accessories

Workshop and detail drawings, trestles (one ell), pencil, hand sketch, engineer's square

Necessary previous knowledge

Measuring, scribing, angling, use of marking-out marks, reading of drawings, reading of tabular values

Sequence of operations

1. Study workshop and detail drawings and draw hand sketch for determination of timber lengths.
2. Calculate the timber lengths for string transoms and roof rafters and the recess sizes for scribing.

Calculation method:

Length of string transom (V)

$$V = (250 + 1134 + 120) \text{ mm} = 1710 \text{ mm}$$

V chosen = 1750 mm

Length of roof rafter (Vl_0)

$$\begin{aligned} Vl_0 &= X^2 + V^2 \\ &= 840^2 \text{ mm}^2 + (250 + 1340 + 960)^2 \text{ mm}^2 \end{aligned}$$

$$Vl_0 = 2684.8 \text{ mm, chosen} = 2750 \text{ mm}$$

Recess sizes (Vl_1 , Vl_2)

$$Vl_1 : V = X : VII$$

$$Vl_1 = \frac{V \cdot VIII}{X}$$

Comments

See working drawings 3 and 7 and calculation method below!

$$Vl_2 = \frac{VIII}{\tan_2} = \frac{120 \text{ mm}}{0.5045}$$

$$Vl_2 = 237.9 \text{ mm}$$

$$= \frac{2550 \text{ mm} \cdot 120 \text{ mm}}{840 \text{ mm}}$$

$$\alpha_2 = 180 \text{ degrees} - (135 \text{ degrees} + 18.23 \text{ degrees})$$

$$\alpha_2 = 26.77 \text{ degrees}$$

$$\tan \alpha = \tan 26.77 \text{ degrees} = 0.5045$$

3. Prepare working place, erect trestles with correct distance.

Check trestles for firm standing and stability!

4. Put string transoms on trestles, decide on joining side and mark with marking-out mark.

Joining side "I" shall have an even face! Use any camber of timbers for top face of string transoms and mark with "IV"!

5. Put string transoms closely together on trestles.

Place string transoms so that face marked with "II" is visible from above! The left ends of string transoms to be about flush, hammer with gentle hammer blows to make them flush, if necessary!

6. Scribe section line at left ends of string transoms and mark with marking-out mark.

Go only as far to the right as to permit a right-angle section to be produced!

7. Angle section line at both joining sides, scribe and mark with marking-out mark.

Place engineer's square exactly!

8. Measure-in maximum length at right ends of string transoms, scribe section line and mark with marking-out mark.

For maximum length of string transoms see calculation method! Measure from section line 6. towards the right, place folding rule in parallel with timber edge, place exactly at section. Let folding rule tongues engage correctly!

9. Angle section line at the joining sides at the right ends of string transoms, scribe and mark with marking-out mark.

Place engineer's square exactly!

10. Measure-in recess sizes from the section lines of the left and right ends of string transoms towards the centre, scribe and mark with marking-out marks.

Do not mix up the recess sizes! The string transoms cannot be interchanged because they are to be cogged in the lintel transom!

11. Measure-in the inclination of the rafters of the main roof at the left ends of the string transoms, scribe and mark with marking-out mark.

Use leg of square for scribing, place it exactly! Scribe inclination on both joining sides! For recess sizes see working drawing 4!

12. Measure-in inclination of cornice at the right ends of the string transoms, scribe and mark with marking-out mark.

Use leg of square for scribing, place it exactly! Sizes see working drawing 4!

13. Measuring-in and scribe the front edge of the lintel transom from the right section line of the string transoms towards the left.

Scribe thin line and use engineer's square.

14. Measure-in to the left and scribe the lintel transom width.

For width see working drawing 4!

15. Angle scribed lines of 13. and 14. at the joining sides and scribe.

Do not scribe the lines over the total timber width!

16. Measure-in and scribe cog depth.

For cog depth see working drawing 4!

17. Mark wood to be removed for cog recess.

Mark with diagonal lines!

- | | |
|--|---|
| 18. Put string transoms apart, scribe on inner faces and mark. | Scribe all lines as on the joining side! |
| 19. Work string transoms, take them off the trestles and store them outside the working area. | Use supports when storing them! |
| 20. Put roof rafters on trestles, decide on joining side and mark with marking-out mark. | Joining side "I" to have an even face!
In the event of any slight camber, mark such faces with "IV" and put them on the trestles with the faces down! |
| 21. Put roof rafters closely together on trestles. | Shown on page 12 but not identified by figures.
Place timbers so that faces marked "II" are visible from above and left ends of roof rafters are about flush, to be made flush by gentle hammer blows, if necessary. |
| 22. Scribe section line at left ends of roof rafters and mark with marking-out mark. | Go only as far to the right as necessary to produce a right-angle section! |
| 23. Angle section lines at the joining sides, scribe and mark with marking-out mark. | Use engineer's square, place it exactly and scribe thin line! |
| 24. Measure-in, scribe and mark with marking-out mark the roof rafter length. | |
| 25. Angle right-end section line of roof rafter length, scribe and mark with marking-out mark. | |
| 26. Measure-in the recess size (VI_1) at the left ends of the roof rafters, scribe and mark with marking-out mark. | Place folding rule exactly at section line and scribe exact size VI_1 , otherwise the roof rafter of the lean-to dormer roof will not be supported on the rafter of the main roof! |
| 27. Scribe roof pitch (inclination) of main roof on joining sides and mark with marking-out marks. | Use leg of square for scribing and place it exactly at the lines! |
| 28. Measure-in the recess size at the right ends of the roof rafters, scribe and mark with marking-out mark. | Place folding rule exactly, otherwise the foot bevel will not fit on the string transom! |
| 29. Scribe rafter foot bevels and mark with marking-out mark. | Use leg of square for scribing and scribe exactly! |
| 30. Put roof rafters apart and scribe on inner faces (III). | Scribe all lines as on the joining sides!
The roof rafters may be placed with the joining sides on the trestles when scribing! |
| 31. Work the roof rafters, take them off the trestles and store them outside the working area. | Use supports for storing them! |
| 32. Clear the working place. | |

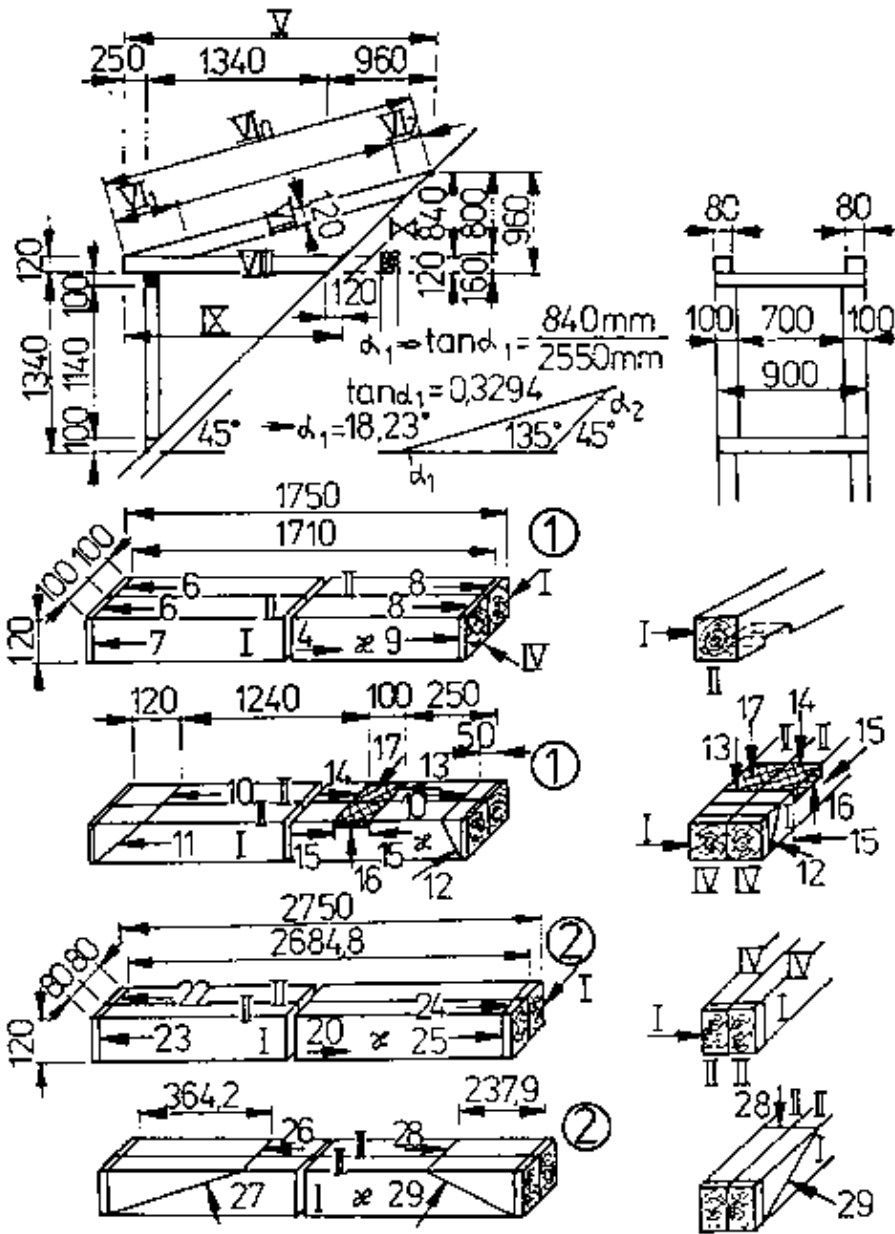

			2.7.
IBE	Joining of the string transoms and roof rafters		3602

Joining of the string transoms and roof rafters

**Attic Completion Work – Course: Timberwork techniques. Trainees'
handbook of lessons**

Table of Contents

<u>Attic Completion Work – Course: Timberwork techniques. Trainees' handbook of lessons</u>	1
<u>1. Purpose of Attic Completion Work</u>	1
<u>2. Types of Roof Superstructures</u>	2
<u>3. Building-in of Roof Superstructures</u>	3
<u>3.1. Building-in of Roof Superstructures in a Couple Roof</u>	3
<u>3.2. Partition of Rooms in the Attic</u>	8
<u>3.3. Covering of Visible Roof Rafters in the Room and of the Roof Superstructure</u>	11

Attic Completion Work – Course: Timberwork techniques. Trainees' handbook of lessons

Institut für berufliche Entwicklung e.V.
Berlin

Original title:
Arbeitsmaterial für den Lernenden
"Herstellen von Dachausbauten"

Author: Rolf Becher

First Edition © IBE

Institut für berufliche Entwicklung e.V.
Parkstraße 21–23
13187 Berlin

Order No.: 93–35–3602/2

1. Purpose of Attic Completion Work

Attic completion work is necessary when the existing space under the roof (attic) shall be used for housing or storing purposes.

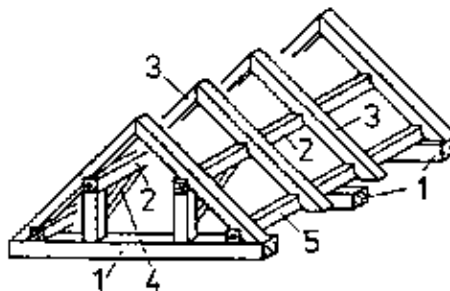

Figure 1 Available space under the roof (attic)

1 attic floor beams, 2 trussed purlin, 3 roof rafter, 4 space under the roof, 5 interior purlin

The constructional details to be taken into account for attics to be used for housing purposes differ from those to be considered for attics intended for storing use.

The use of attics for housing purposes, in any case, necessitates natural lighting and adequate lighting as well as adequate ventilation. This can be achieved by building-in suitable roof superstructures.

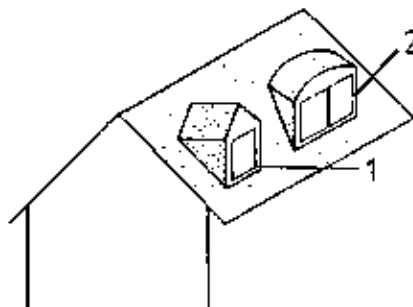

Figure 2 Roof superstructures

1 upright roof window roofed with gable roof, 2 upright roof window roofed with arched lean-to dormer roof

For attics intended for storing use, the insertion of prefabricated lying roof windows in the roofing will do. Roof superstructures for adequate ventilation and natural lighting can already be provided for when a new roof structure is being built.

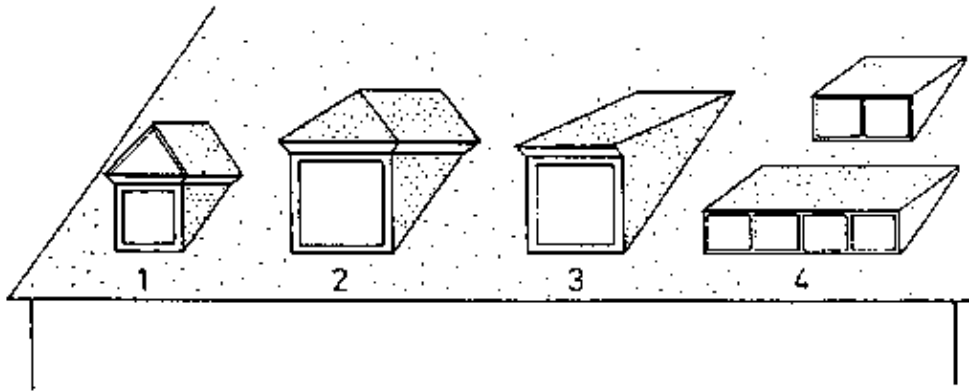

Figure 3 Upright roof windows

1 roofed with gable roof, 2 roofed with hip roof, 3 roofed with lean-to dormer roof, 4 series windows roofed with lean-to dormer roof

The present booklet deals with completion of attics to be used for housing purposes only.

2. Types of Roof Superstructures

Roof superstructures for housing purposes are normally designed as roofed upright windows. For roofs having a roof pitch of less than 50 degrees, upright windows with lean-to dormer or with hip roof are recommended.

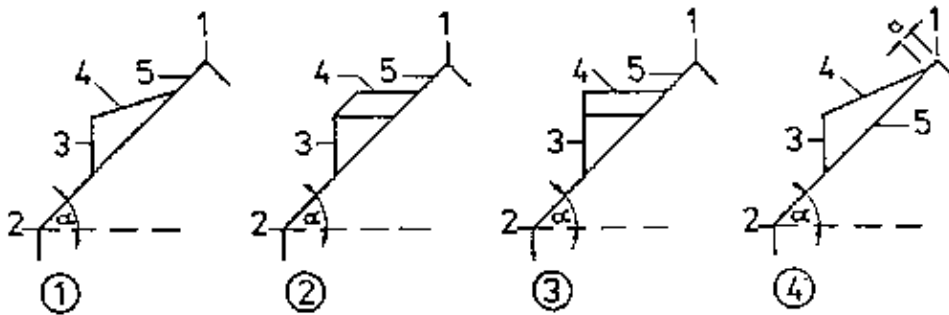

Figure 4 Roof pitch of less than 50 degrees

- (1) Lean-to dormer roof, good solution
- (2) Hip roof, good solution
- (3) Gable roof, bad solution, (4) Lean-to dormer roof, bad solution

1 ridge (main roof), 2 eaves (main roof), 3 roof superstructure, 4 window roof (roof superstructure), 5 rafter (main roof), ? – eaves angle (main roof) α – bonding-in length in the roofing

For the lean-to dormer it is important that the bonding-in in the roofing is not too near to the roof ridge. If upright roof windows of roofs having such pitches are roofed with gable roofs, they make a poor impression. The ridge of the window roof appears too long – see Fig. 4.

For roof pitches of more than 50 degrees, an upright roof window roofed with gable roof is recommended.

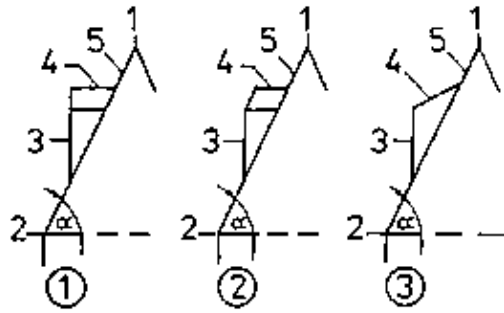

Figure 5 Roof pitch of more than 50 degrees

(1) Gable roof, good solution (2) Hip roof, bad solution (3) Lean-to dormer roof, bad solution

1 ridge (main roof), 2 eaves (main roof), 3 roof superstructure, 4 window roof (roof superstructure), 5 rafter (main roof), ? – eaves angle (main roof) a – bonding-in length in the roofing

If in this case the window is roofed with a lean-to dormer or hip roof, it makes a bad appearance because the ridge line appears too short (see Fig. 5).

Why does attic completion work also call for roof superstructures?

Why should the roof superstructure be suited to the existing roof pitch?

3. Building-in of Roof Superstructures

3.1. Building-in of Roof Superstructures in a Couple Roof

If the attics shall be used for housing purposes, roof windows are to be built in for natural lighting and ventilation of the living space.

The width of roof windows is limited by the rafter distance.

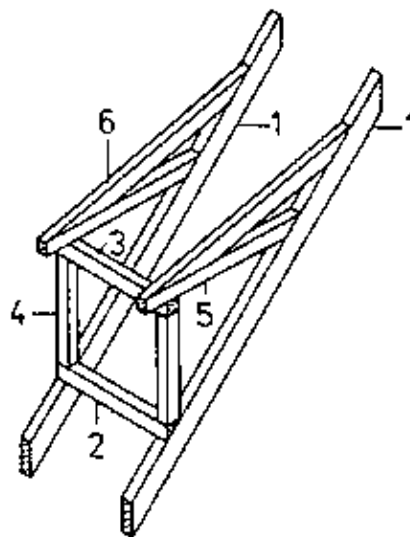

Figure 6 Roof window in the clearance between the roof rafters (rafter distance)

1 rafter of main roof, 2 parapet trimming, 3 lintel transom, 4 window post, 5 string transom, 6 rafter of lean-to dormer roof of window

This is of special importance for couple roofs because the couples support each other at the ridge and the acting supporting forces in the roof rafter are carried off to the end cogging.

Too low supporting forces in the roof rafters involve the danger of collapse!

In this respect, it does not matter whether the roof structure is supported by a wooden beam or solid ceiling.

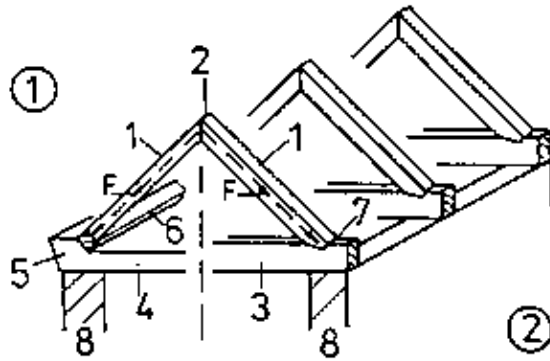

Figure 7 Direction of forces in a couple roof

- (1) Solid ceiling
- (2) Wooden beam ceiling

1 rafter, 2 ridge, 3 wooden beam, 4 solid ceiling, 5 cornice, 6 inferior runner, 7 end cogging, 8 ceiling support

In the couple roof, the width of the roof window is dictated by the clearance between the roof rafters.

If roof windows of greater width than the clearance between the rafters are to be built into a purlin roof, the rafters must be interrupted by a rafter trimming to be inserted.

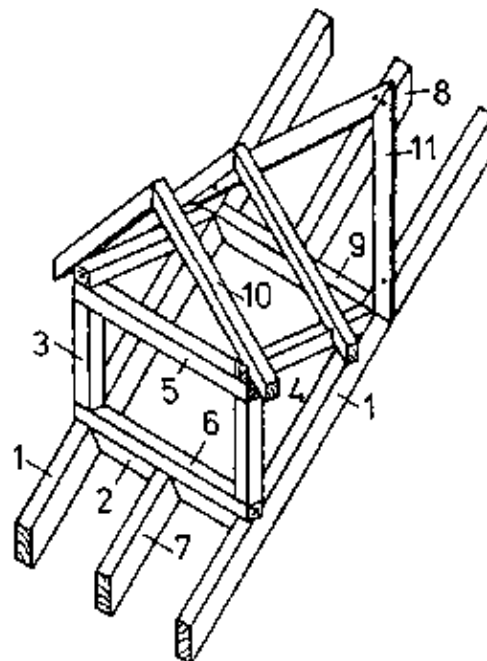

Figure 8 Roof window with interrupted rafters

1 trimmer rafter, 2 parapet trimming, 3 window post, 4 string transom, 5 lintel transom, 6 parapet transom, 7 lower tail rafter, 8 upper tail rafter, 9 rafter trimming, 10 rafter for gable roof of window, 11 valley board

Insertion of a rafter trimming, however, means to change the direction of forces of the supporting structure!

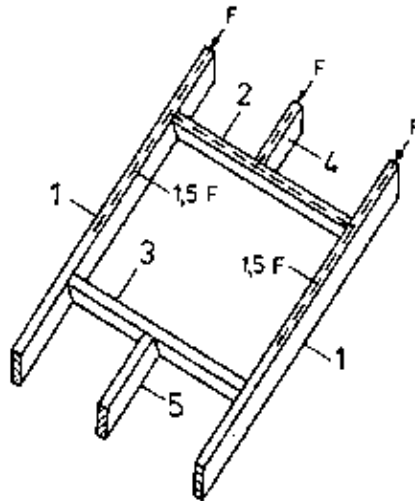

Figure 9 Change of direction of forces

F – acting force

1 trimmer rafter, 2 rafter trimming, 3 parapet trimming,
4 upper tail rafter, 5 lower tail rafter

In a couple roof it is not possible to interrupt the rafters for windows of greater width!

Why is it not possible to interrupt the rafter in a couple roof for windows of greater width?

Without static verification it is not allowed to interrupt more than one rafter in a purlin roof.

If several roof windows are required for natural lighting of the living space, it is to be made sure that one trimmer rafter must only support one lower and one upper rafter trimming.

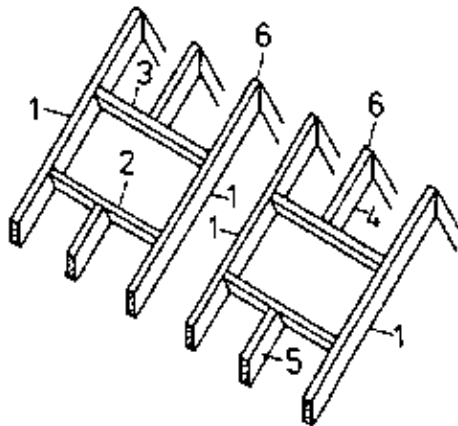

Figure 10 Lower and upper rafter trimming

1 trimmer rafter, 2 parapet trimming, 3 rafter trimming, 4 upper tail rafter, 5 lower tail rafter, 6 ridge

Why must a trimmer rafter not support a rafter trimming at both sides?

In order to support the two tail rafters, rafter trimmings are inserted.

The parapet trimming should be inserted at a height allowing a parapet transom to be built in.

The surface of the parapet transom should not exceed the perpendicular size of 900 mm.

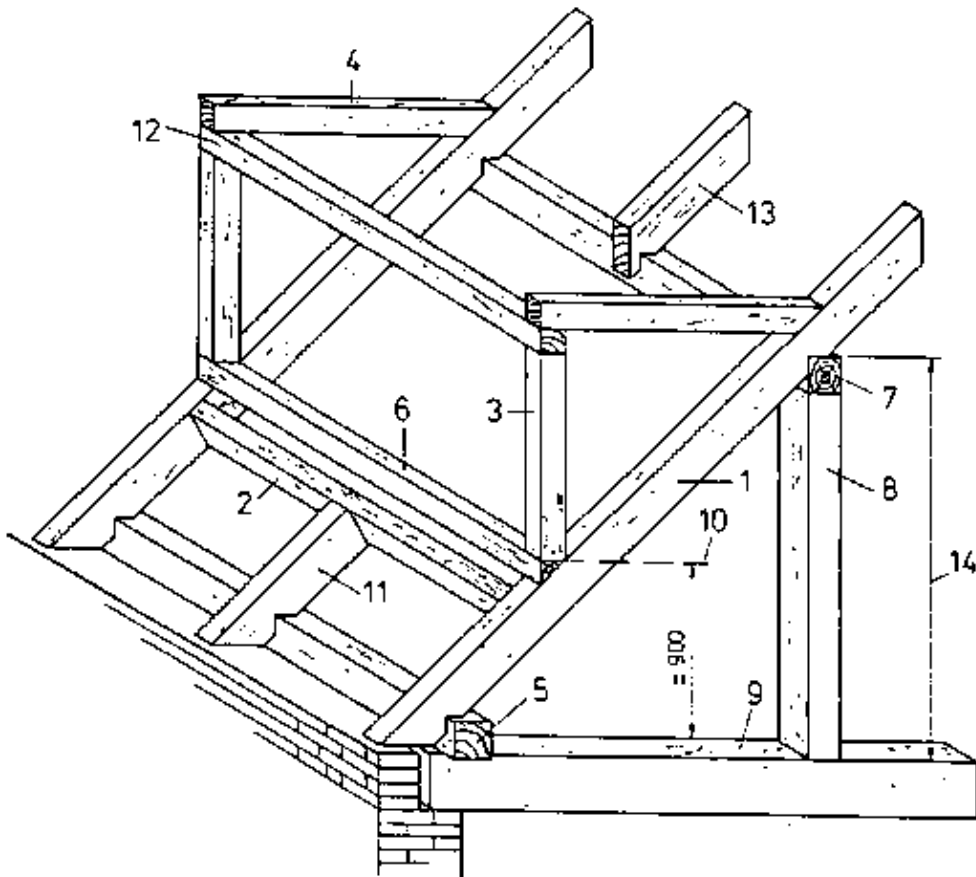

Figure 11 Roof window height limitation

1 trimmer rafter, 2 parapet trimming, 3 window post, 4 string transom, 5 inferior purlin, 6 parapet transom, 7 trussed purlin, 8 king post, 9 attic beam, 10 parapet height, 11 lower tail rafter, 12 intel transom, 13 upper tail rafter, 14 surface of trussed purlin

The upper rafter trimming can be omitted if the upper tail rafter rests on a trussed purlin.

The height of windows in purlin roofs with double upright truss is limited by the trussed purlin.

It is advantageous when the surfaces of the trussed purlin and lintel transom are located at equal height which provides for a uniform room height when fixing the subceiling.

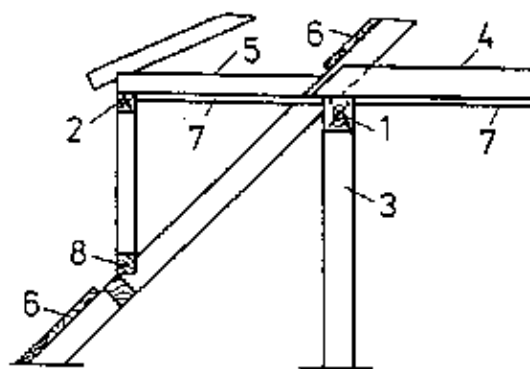

Figure 12 Limitation of roof window height

1 trussed purlin, 2 lintel transom, 3 king post, 4 valley beam, 5 string transom, 6 roof boards (roofing), 7 subceiling, 8 parapet transom

The visible part of the trussed purlin in the subceiling can be ground and painted or covered (faced).

Conclusions:

- For purlin roofs it is recommended to insert windows fitting into the clearance of the rafters.
- If a window of greater width is necessary, no more than one rafter must be interrupted unless static verification is available.
- It is a must that one trimmer rafter only supports one rafter trimming at one side.
- The number of adjacent rafters that can be interrupted is limited.
- Constructional details.

The opening in the roofing must only be as big as to allow the subceiling or protection against trickling matter to be provided in the roof superstructure (see also Fig. 12).

The timberwork of the roof superstructure to be built in is to be joined.

Though, normally, rafter trimmings and tail rafters are joined by mortise-and-tenon joints, for attic completion work for housing purposes it is recommended to use screw-on squares to provide greater stability.

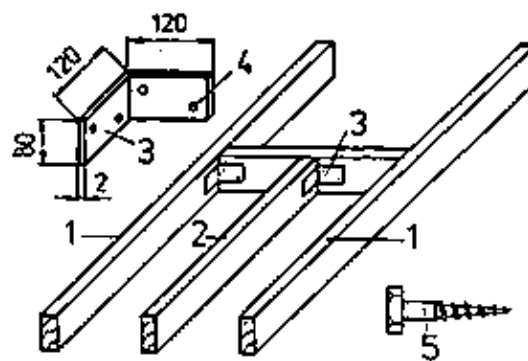

Figure 13 Joining of structural parts

1 trimmer rafter, 2 tail rafter, 3 steel square, 4 borehole, 5 hexagon-head wood screw

Reasons:

Because of the change of direction of acting forces, there is greater load on the trimmer rafter than before. The cross section of the rafter would be additionally weakened by the mortise.

What effect would the weakened cross section of the trimmer rafter have on its bearing capacity?

The window post has not necessarily to be the corner post but it may be placed inwards depending on the width of the window.

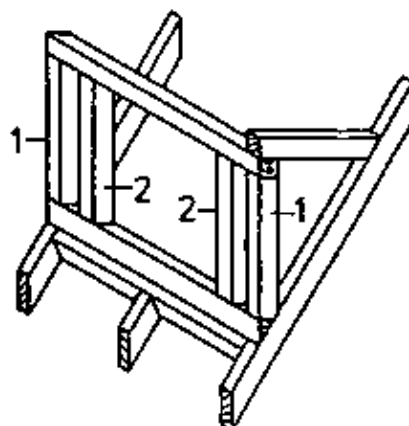

Figure 14 Arrangement of window and corner posts

1 corner post, 2 window post

A profiled batten for fixing the window frame can be fixed to the window post and lintel transom.

The roof rafters of the lean-to dormer roof of the window are supported on the roof rafters of the main roof with oblique notch. The roof rafters of the gable roof of the window are joined with the string transom by a triangular notch (birdsmouth).

The parapet transom and string transom are supported on the roof rafter or trimmer rafter and not sunk in into the roof rafter.

Why should the parapet transom not be sunk in into the roof rafter?

For hip roofs of windows, a packing piece is to be placed on the lintel transom to birdsmouth the jack rafters.

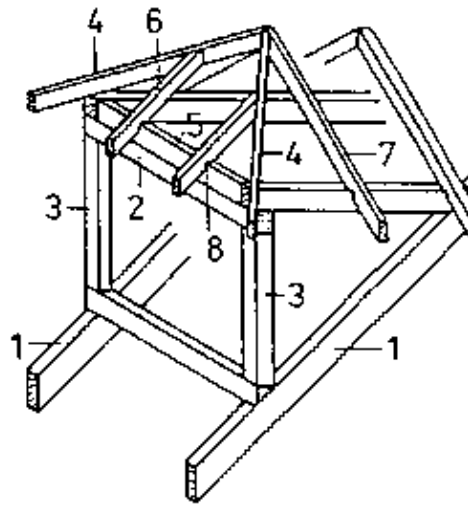

Figure 15 Hip roof of window

1 trimmer rafter, 2 lintel transom, 3 window post, 4 hip rafter of window roof, 5 packing piece, 6 jack rafter, 7 rafter of window roof, 8 triangular notch (birdsmouth)

The valley boards are to be nailed onto the roof rafters. The width and height of the rafter trimmings are to be suited to the existing roof rafters.

A cross section of $100 \cdot 100 \text{ mm}^2$ or $120 \cdot 120 \text{ mm}^2$ is recommended for posts and transoms.

The rafter cross section of gable or hip roofs of windows should be $60 \cdot 120 \text{ mm}^2$ and of lean-to dormer roofs of windows $80 \cdot 140 \text{ mm}^2$.

Before interrupting a roof rafter, the rafter to be interrupted is to be underpropped. The prop is to be placed on the attic beam and to be secured against displacement or slipping off!

The diameter of the prop should be big enough to avoid collapse of the prop and accidents caused thereby!

The top end of the prop should at least have a diameter of 100 mm.

3.2. Partition of Rooms in the Attic

The rooms to be built into the existing space under the roof (attic) must be limited in their floor space and height. With a purlin roof, the length, width and height of the rooms are not optional but depend on the supporting structure of the roof.

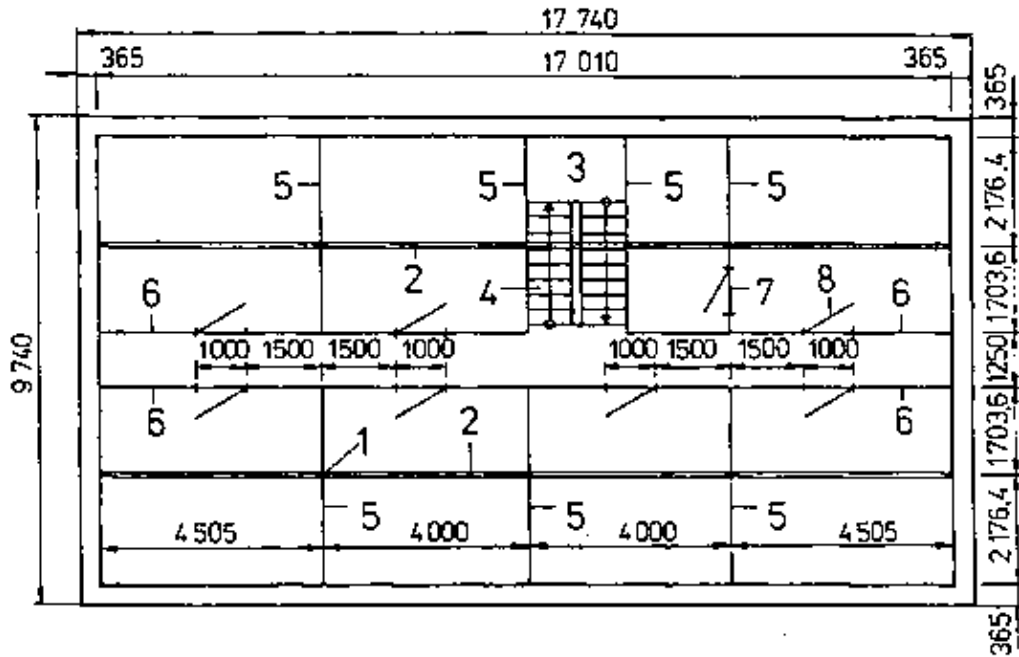

Figure 16 Partition of rooms in the attic

1 king post, 2 trussed purlin, 3 stair landing, 4 staircase, 5 partition walls of rooms, 6 partition wall for attic walkway, 7 door to be built in, 8 opening direction of door

Any king posts and struts in the attic are fixed points for the partition of rooms since supporting structural parts must not be removed or interrupted.

Existing angle braces can be covered or included in the partition of rooms.

Why must supporting structural parts not be removed or interrupted?

Upper limitation of rooms

If purlin roofs have no valley beams, wooden beams must be built in for fixing of the subceiling. The wooden beams are to be placed and fixed on the trussed purlin.

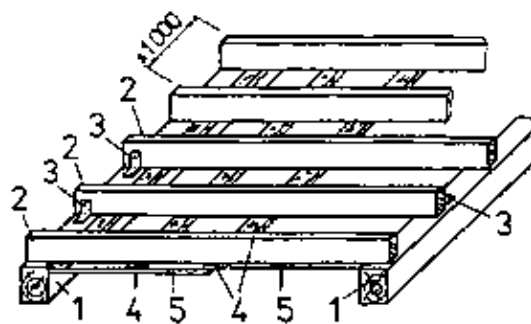

Figure 17 Fixing of wooden beams

1 Trussed purlin, 2 wooden beam, 3 steel square, 4 additional rafters, 5 protection against trickling matter (faced particle boards)

Steel squares with boreholes are recommended for fixing the wooden beams to the trussed purlins by means of hexagon-head wood screws.

Fixing to the trussed purling is necessary to prevent any displacement of the wooden beams or lift-off when the subceiling is nailed from below.

The distance of the wooden beams to be built in must not exceed 1000 mm.

The cross section of the wooden beams depends on the span between the trussed purlins.

With a wooden beam distance of 1000 mm, a span between the trussed purlins of 4000 mm and no top ceiling, a beam cross section of at least 100 cm² will be required.

If the spans between the trussed purlins are greater or if a top ceiling is to be provided in order to make use of the room above, a top beam can be built in to reduce the span. Otherwise the cross sections of the wooden beams must be statically verified.

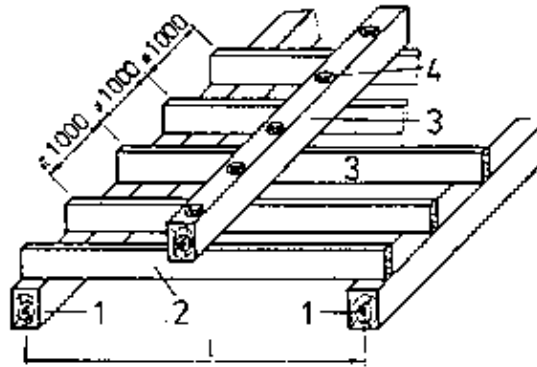

Figure 18 Built-in top beam

1 trussed purlin, 2 wooden beam, 3 top beam, 4 machine bolt | span between purlins

The wooden beams and the top beam are to be connected with machine bolts.

For safety reasons, static calculations are also required for the top beam!

In order to make the subceiling as light as possible, it is recommended to use faced particle boards.

Whether the particle boards can be directly fixed to the existing valley beams or built-in wooden beams or whether additional rafters will be required, depends on the working/processing instructions for the particle boards used.

Wood-wool slabs are not recommended because they need to be plastered which would result in additional load on the wooden beams. If sound or heat-insulating measures are required, insulating mats are to be placed on the particle boards or other types of protection against trickling matter used.

At the existing valley beams or built-in wooden beams the insulating mats are to be placed upwards and to be fixed with wooden strips.

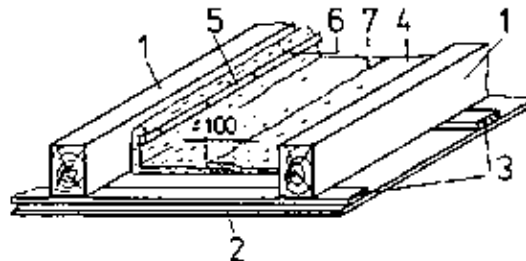

Figure 19 Mounting of sound-insulating mats

1 wooden beam or valley beam, 2 protection against trickling matter, 3 additional rafters, 4 sound-insulating mat, 5 lath, 6 nail, 7 longitudinal side of insulating mat

If the mats are not wide enough, they are to be placed so as to overlap at their longitudinal sides by at least 100 mm, thus avoiding sound or thermal bridges.

Lateral limitation of rooms

Laterally the rooms can be limited by partition walls with king posts and struts being fixed points.

The king posts can be used for stabilization of the partition walls by fixing the wall covering (facing) directly to them. Between the king posts a framework will be required to hold the wall covering.

The thickness of the partition wall depends on the dimensions of the king posts.

Door openings are to be provided in the partition walls for access to the living rooms in the partitioned attic.

The partition walls inserted to permit use of the attic for housing purposes must, in any case, have sound insulation.

Why must the living rooms in the attic have sound insulation?

For sound insulation the partition walls are to be provided with sound-insulating material. Textile fibre mats, mineral wool mats or glass wool mats are recommended as sound-insulating material. When mounting the sound-insulating mats it is to be made sure that no sound bridges are produced.

Why must no sound bridges be produced when mounting the sound-insulating mats?

To avoid sound bridges, the sound-insulating mats are to be placed so as to overlap at the heading and framing timbers of the framework for the wall covering and are to be fixed with laths.

When mounting the sound-insulating mats, special care is required at the top connection in the area of the ceiling. Here, too, it is indispensable to fix the insulating mats with laths at the transom of the framework, at the trussed purlin, if used, at the valley beam or built-in wooden beams.

Neglect of fixing to the timberwork would result in a waste of material, money and labour employed in the entire sound-proofing measure.

When mounting the wall covering, it is to be made sure that no openings are left to provide access for animals who prefer to live in textile insulating materials and would destroy the insulating mats, thus making the sound insulation ineffective.

3.3. Covering of Visible Roof Rafters in the Room and of the Roof Superstructure

If the rooms in the attic are to be used for housing purposes, the visible roof rafters are to be covered, too. For this purpose, the same material should be used as for the partition wall.

Whether or not additional rafters are to be applied to the roof rafters, depends on the material used and on the working/processing instructions for such material.

In the event of wood covering, the covering can be directly nailed to the roof rafters with hidden nails or be screwed with visible screws.

In any case, the cavity between the roofing and wall covering is to be sound-insulated using the same material. The covering should be connected with the timbering in the same way as for the partition walls.

Before mounting the sound-insulating material, the area of the eaves angle and rafter foot should be particularly checked for access by animals.

But the necessary ventilation for the roof structure is to be ensured to avoid infestation of wood with animal pests which would destroy the roof structure over the years.

When joining the roof superstructure, the necessary covering of the timberwork should already be taken into account to avoid necessary or additional timbers to be included at a later stage.

The same material as used for the wall covering should be used for covering the rafters. When mounting the sound-insulating mats, sound bridges should be avoided by any means.

Manufacture of Ceilings – Course: Timberwork techniques. Instruction examples for practical vocational training

Table of Contents

<u>Manufacture of Ceilings – Course: Timberwork techniques. Instruction examples for practical vocational training</u>	1
<u>Preliminary Remarks</u>	1
<u>Instruction Example 4.1.: Calculation of Cross Sections of Wooden Beams</u>	1
<u>Instruction Example 4.2.: Determination of the Pitch Size</u>	4
<u>Instruction Example 4.3.: Preparation of a List of Timber</u>	7
<u>Instruction Example 4.4.: Preparation of the Wall Plate Bearing</u>	12
<u>Instruction Example 4.5.: Placing of Wall Plates</u>	14
<u>Instruction Example 4.6.: Preparation of the Wooden Beam Framing</u>	17

Manufacture of Ceilings – Course: Timberwork techniques. Instruction examples for practical vocational training

Institut für berufliche Entwicklung e.V.
Berlin

Original title:
Lehrbeispiele für die berufspraktische Ausbildung
“Herstellen von Deckenkonstruktionen”

Author: Rolf Becher

First Edition © IBE

Institut für berufliche Entwicklung e.V.
Parkstraße 21/23
13187 Berlin

Order No.: 93–33–3604/2

Preliminary Remarks

The present booklet contains 6 selected instruction examples to practise and consolidate knowledge and skill in the manufacture of ceilings.

The instruction examples have been selected so that the individual exercises can be practised separately or successively, one based on the previous one.

For the instruction examples 4 to 6, the necessary hand tools, measuring and testing means and auxiliary accessories are specified to facilitate the preparation and execution of the work. Moreover, the previous knowledge, which is necessary in addition to knowledge of the technique of “manufacture of ceilings”, is also stated for each instruction example and should be recapitulated at the beginning.

Perspective and working drawings showing the required shapes and dimensions are attached to the instruction examples.

Instruction Example 4.1.: Calculation of Cross Sections of Wooden Beams

This example shall serve to practise the use of tables and the application of formulas for the calculation of wooden beam sections.

The cross sections of wooden beams for a ceiling of a warehouse building shall be calculated.

The wooden beam framing will be provided with a 30 mm thick flooring.

If the beam sections shown in the table are not available, other cross sections are to be proposed.

Auxiliary accessories

Paper, pencil, table No. 3 from the “Trainees’ Handbook of Lessons”, slide rule or calculator/computer

Necessary previous knowledge

Reading of tables, multiplication, division, raising to a power, extraction of roots

Sequence of operations	Comments
------------------------	----------

<p>1. Determine the beam section for a room of 3125 mm clear width.</p>	<p>Find out T_{zul} $T_{zul} = 1000 \text{ mm}$ Look for the size 3125 mm in column "w" of the table. If the size is not shown in the table, <u>round off to the next full decimetre.</u> Go to the right in line 3200 mm and read the beam section in the column "1000 mm".</p>
<p>2. Write down the reading of the beam section.</p>	<p>14/18 cm²</p>
<p>3. Determine the beam section for a room of 4635 mm.</p>	<p>Look for the size 4700 mm in column "w" of the table. Go to the right in line 4700 mm and read the beam section in the column "1000 mm".</p>
<p>4. Write down the beam section read.</p>	<p>22/22 cm²</p>
<p>5. Determine the beam sections for "replacement beams" – for 14/18 cm² beam section.</p>	<p>Formula $W_x = (b \cdot h^2) / 6$ and $\text{formulah} = \sqrt{\frac{6 W_x}{b}}$ to be applied assuming a width of 100 mm and 120 mm.</p>
<p>Required: W_x $W_x = (b \cdot h^2) / 6$</p>	
<p>$W_x = \frac{14 \text{ cm} \cdot 18^2 \text{ cm}^2}{6}$ Known: $b = 14 \text{ cm}$ $h = 18 \text{ cm}$ $W_x = 756 \text{ cm}^3$</p>	<p>This section modulus is to be maintained!</p>
<p>Required: h</p> <p>$h = \sqrt{\frac{6 \cdot W_x}{b}}$</p>	
<p>$h = \sqrt{\frac{6 \cdot 756 \text{ cm}^3}{10 \text{ cm}}}$ Known: $W = 756 \text{ cm}^3$ $b = 10 \text{ cm}$ $h = 21.2 \text{ cm}$</p>	
<p>Beam section <u>10/22 cm²</u></p>	
<p>Required: h ($b = 120 \text{ mm}$)</p>	
<p>$h = \sqrt{\frac{6 \cdot 756 \text{ cm}^3}{12 \text{ cm}}}$ Known: $W = 756 \text{ cm}^3$ $b = 12 \text{ cm}$ $h = 19.4 \text{ cm}$</p>	
<p>Beam section <u>12/20 cm²</u></p>	
<p>– Beam section 22/22 cm²</p>	
<p>Required: W</p> <p>$W_x = \frac{b \cdot h^2}{6}$</p>	

$W_x = \frac{22 \text{ cm} \cdot 222 \text{ cm}^2}{6}$ <p>Known: $b = 22 \text{ cm}$ $h = 22 \text{ cm}$ $W_x = 1774.7 \text{ cm}^3$</p>	<p>assuming a width of 160 mm, 180 mm and 200 mm</p>
<p>Required: h</p> $h = \sqrt{\frac{6 \cdot W_x}{b}}$	
<p>Known: $W_x = 1774.7 \text{ cm}^3$</p> $h = \sqrt{\frac{6 \cdot 1774.7 \text{ cm}^3}{16 \text{ cm}}}$ <p>$b = 16 \text{ cm}$ $h = 25.7 \text{ cm}$</p>	
<p>Beam section <u>16/26 cm²</u></p>	
<p>Required: $h_{(b = 18 \text{ cm})}$</p>	
<p>Known: $W_x = 1774.7 \text{ cm}^3$</p> $h = \sqrt{\frac{6 \cdot 1774.7 \text{ cm}^3}{18 \text{ cm}}}$ <p>$b = 18 \text{ cm}$ $h = 24.3 \text{ cm}$</p>	
<p>Beam section <u>18/26 cm²</u></p>	
<p>Required: $h_{(b = 20 \text{ cm})}$</p>	
<p>Known: $W_x = 1774.7 \text{ cm}^3$</p> $h = \sqrt{\frac{6 \cdot 1774.7 \text{ cm}^3}{20 \text{ cm}}}$ <p>$b = 20 \text{ cm}$ $h = 23.07 \text{ cm}$</p>	
<p>Beam section <u>20/24 cm²</u></p>	

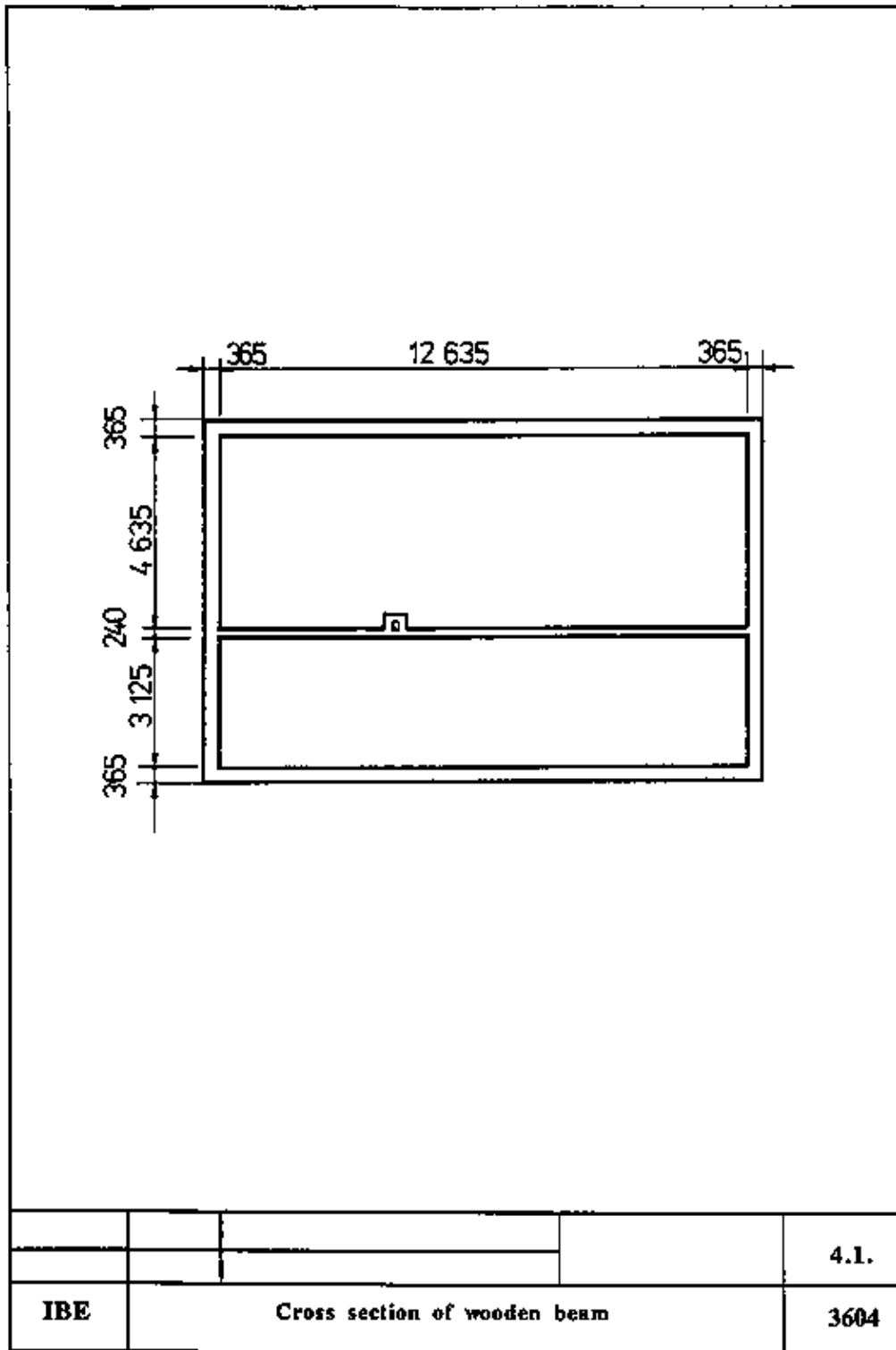

Cross section of wooden beam

Instruction Example 4.2.: Determination of the Pitch Size

The pitch size between the fixed joining beams for the roof framing shall be determined.

Assumed to be known:

- Beam section 180/180 cm²
- $T_{zul} = 800$ mm
- Joining beam distance = 4000 mm

Auxiliary accessories

Paper, pencil, slide rule or calculator/computer

Necessary previous knowledge

Addition, subtraction, multiplication, division

Sequence of operations	Comments
1. Determine the pitch size for the distance 1602.5 mm	
$T = \frac{L_r}{n'_F}$ Requ.: T	
$L_r = L - \frac{b_1 + b_2}{2}$ Known:	
$n_F = \frac{L_r}{T_{zul}}$	
$L = B - c$	
$b_1 = b_2 = 0 \text{ mm}$	
$T_{zul} = 800 \text{ mm}$	Between gable and joining beam because the size extends up to the front edge of the joining beam.
$B = 1602.5 \text{ mm}$	
$c = 20 \text{ mm}$	
$L = 1602.5 \text{ mm} - 20 \text{ mm}$ $L = 1582.5 \text{ mm}$	
$L_r = 1582.5 \text{ mm} - 0.0 \text{ mm}$ $L_r = 1582.5 \text{ mm}$	
$n_F = \frac{1582.5 \text{ mm}}{800.0 \text{ mm}} = 1.9 n'_F = 2$	
$T = \frac{1582.5 \text{ mm}}{2}$ $T = 791.25 \text{ mm}$	
2. Determine the pitch size for the distance 4000 mm	
$T = \frac{L_r}{n'_F}$ Requ.: T	
Known: $L_r = 4000 \text{ mm}$	Size extends from the front edge of the joining beam up to the front edge of the joining beam!
$n_F = \frac{L_r}{T_{zul}}$	

$T_{zul} = 800 \text{ mm}$	
$n_F = \frac{4000 \text{ mm}}{800 \text{ mm}} = 5 \quad n'_F = 5$	
$T = \frac{4000 \text{ mm}}{5}$ $T = 800 \text{ mm}$	
3. Determine the pitch size for the distance 1782.5 mm	
Requ.: T $T = \frac{L_r}{n'_F}$	
Known: $L_r = L - b_2$	$b_1 = 0.0 \text{ mm}$ because b_1 is within the distance. The size extends from the front edge of the joining beam up to the gable wall.
$n_F = \frac{L_r}{T_{zul}}$	
$L = B - c$	
$b_2 = 180 \text{ mm}$	The size extends from the front edge of the joining beam up to the gable wall.
$T_{zul} = 800 \text{ mm}$	
$B = 1782.5 \text{ mm}; c = 20 \text{ mm}$	
$L = 1182.5 \text{ mm} - 20 \text{ mm}$ $L = 1162.5 \text{ mm}$	
$L_r = 1162.5 \text{ mm} - 180 \text{ mm}$ $L_r = 982.5 \text{ mm}$	
$n_F = \frac{982.5 \text{ mm}}{800.0 \text{ mm}} = 1.228 \quad n'_F = 2$	
$T = \frac{982.5 \text{ mm}}{2}$	
$T = 491.25 \text{ mm}$	

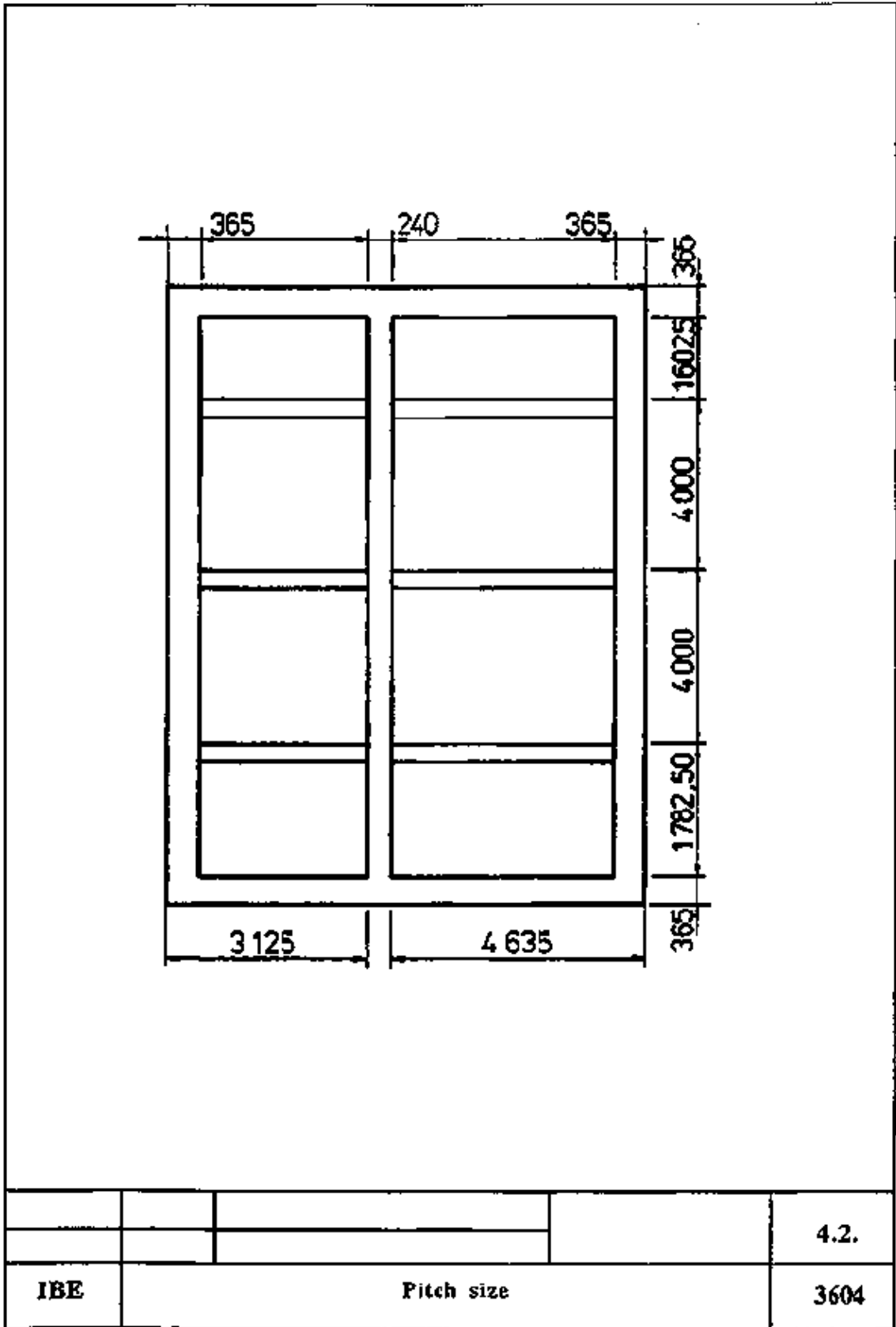

Pitch size

Instruction Example 4.3.: Preparation of a List of Timber

A list of timber for ordering wooden beams for the 2nd floor ceiling of a building of 10,990 mm length and 7,865 mm width shall be prepared.

Assumed to be known:

- Trimmer beam: 180/200 mm²
- Beam trimming: 180/200 mm²
- Filling timbers: 80/200 mm²

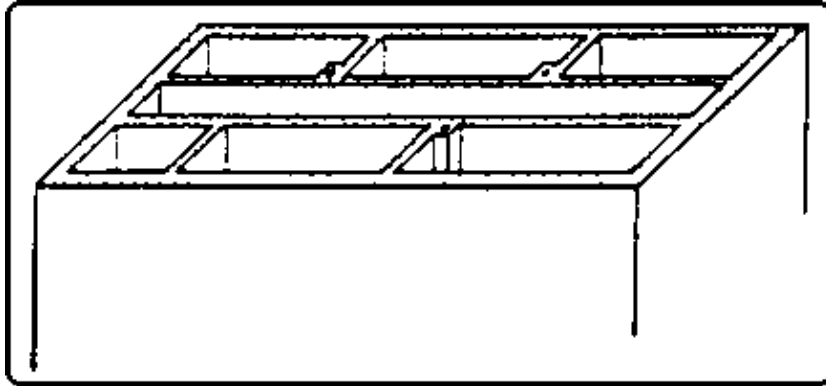

Auxiliary accessories

Form of list of timber, working drawing, paper, pencil, calculator/computer

Necessary previous knowledge

Reading of drawings, addition, subtraction, multiplication

Explanations to the form of list of timber

1 serial number, 2 quantity (pieces), 3 designation, 4 cross section in cm/cm, 5 individual length in mm, 6 m according to cross section of timber, 7 total length in m, 8 waste in %, 9 total length and waste, 10 volume in m³, 11 total volume in m³

Instruction Example 4.4.: Preparation of the Wall Plate Bearing

The bearing to support the wall plate shall be made.

Assumed to be known:

- Height of the metre mark as per drawing 1450 mm
- Cross section of the wall plate timber 80/60 mm²
- Thickness of outer wall 365 mm
- Plaster base: 25 mm thick wood-wool board

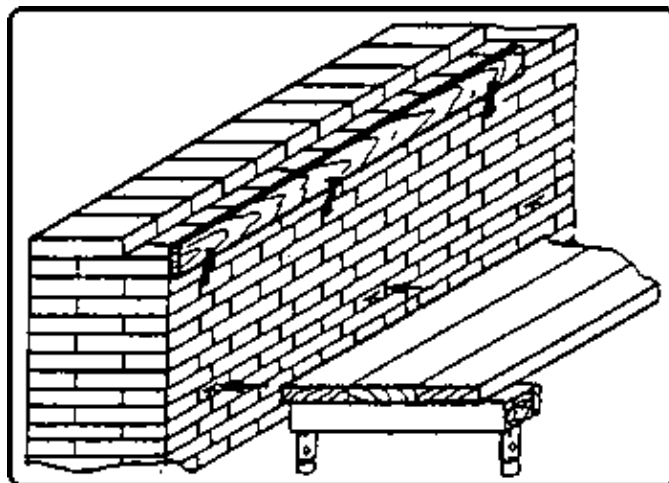

Hand tools

Hammer, trowel, float

Measuring and testing means

Folding rule, water level, measuring rod 1450 mm long

Auxiliary accessories

Levelling board, pencil, brackets, mortar, scaffolding

Necessary previous knowledge

Reading of drawings, measuring, levelling

Explanations to the working drawing

1 metre mark, 2 levelling board, 3 bracket, 4 scaffolding, 5 bearing for wall plates

Sequence of operations	Comments
1 Check the bearing height starting from the metre marks.	Scribe the measured size with pencil on the wall. Check on both outer walls.
2. Compare the biggest gauge size with the drawing for the respective building.	Find out any difference (starting from the biggest gauge size). If the brickwork is too high, remove one layer.

3. Hold the upper side of the levelling board flush with the bearing level and fix it to the wall by means of brackets.	Use measuring rod. Put on water level for checking.
4. Apply mortar up to the upper side of the levelling board.	The consistency of the mortar is important. (It should be easy to distribute but also set quickly)
5. Distribute the mortar.	Make sure that it is flush with the upper side of the levelling board.
6. Remove the brackets, take off the levelling board and reset it.	Take off the levelling board downwards! (Damage to the surface)
7. Repeat operations 4–6 above.	

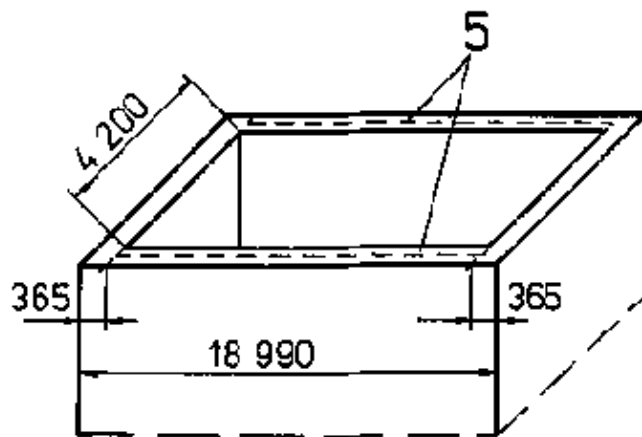
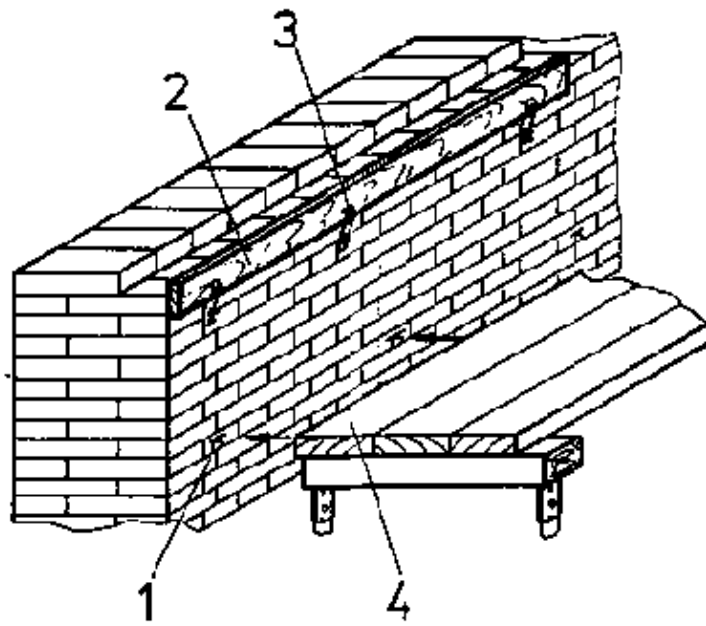

			4.4.
IBE	Wall plates		3604

Wall plates

Instruction Example 4.5.: Placing of Wall Plates

The wall plates for the wooden beam ceiling are to be prepared and placed.

Assumed to be known:

- Length of building = 18,990 mm
- Thickness of outer wall = 365 mm
- Wall plate section: 80/60 mm²
- Timber lengths for wall plates: 4000 mm
- Wooden beams are to be secured with pin connection

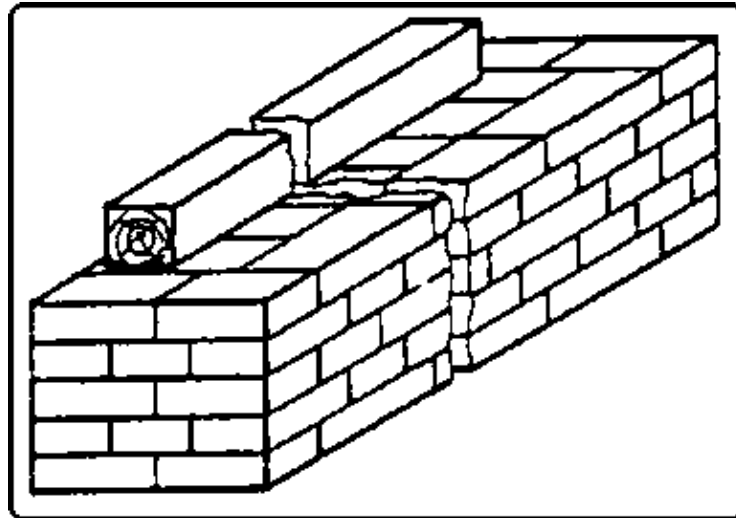

Hand tools

Hammer, hand saw, mortise chisel 20 mm, planing chisel 35 mm, axe

Measuring and testing means

Folding rule, water level, square, bricklayer's line, measuring tape

Auxiliary accessories

Pencil, inside scaffolding (at working level), trestles, barrier cardboard (building paper), nails 3.1/70

Necessary previous knowledge

Reading of drawings, measuring, scribing, sawing, mortising, plastering, aligning

Explanations to the working drawing

1 wall plates

Sequence of operations	Comments
1. Measure the clear width between the gables.	Use a measuring tape.
2. Determine the number of wall plates required for one side.	18,260 mm: 4000 mm = 4.5 which means: 5 wall plates for one side = totally 10 wall plates.
3. Place the trestles on the floor ceiling and put on 6 wall plates.	Inspect the wall plates and put slight camber at top.
4. Scribe half joints at both sides and prepare the wall plates.	Pay attention to jointing side. Use a square.
5. Remove the wall plates from the trestles and store them at the side.	Make sure that there is enough room to move (danger of accidents)!
6. Put the remaining 4 wall plates on the trestles and scribe and prepare half joints at one side.	Pay attention to camber and jointing side.

7. Cut strips of barrier card-board and put them on the bearing.	Strips must not project at the inside of the outer wall.
8. Place wall plates on one outer wall, join them and drive a nail into the halved joint.	Use correct nail length. One wall plate with half joint at one side and three wall plates with half joint at both sides.
9. Measure the difference at the bearing, transfer and scribe such size on the wall plate, saw off the wall plate.	Check the position of the wall plate at the other end! Place the wall plate flush with the inner wall of the gable.
10. Put on, join and nail the sawn off wall plate.	Drive in one nail.
11. Fix the line at both ends of the joined wall plates, tension it and align the wall plates.	Do not drive the line. Take into account the thickness of the plaster base.
12. Drive a second nail into the halved joints.	
13. Mount the wall plate at the opposite outer wall.	Repeat operations 7 to 12 above.

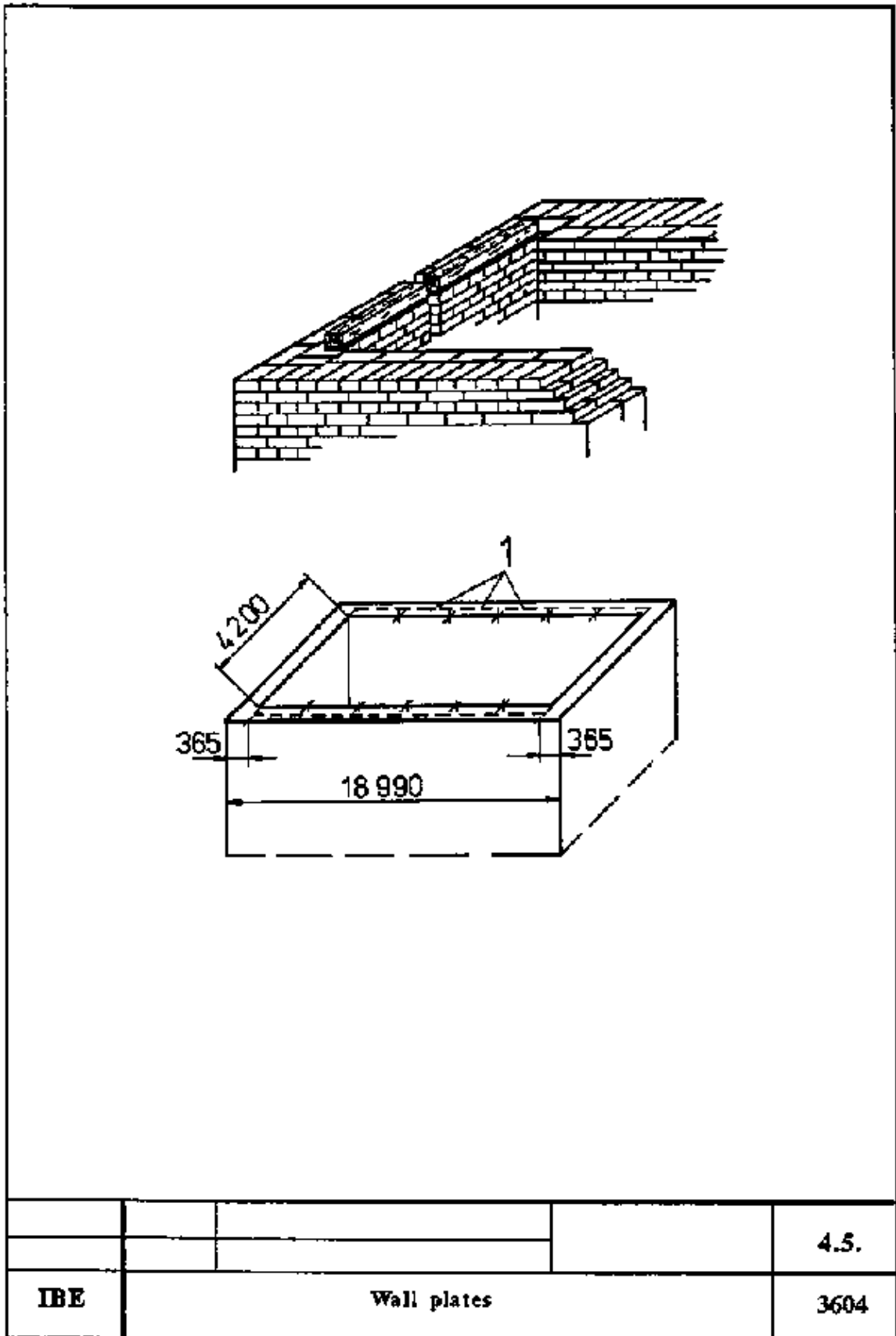

Wall plates

Instruction Example 4.6.: Preparation of the Wooden Beam Framing

A wooden beam framing shall be prepared over a room with a clear width of 12,635 mm.

Assumed to be known:

- 20 mm thick batten floor
- Wooden beam section: 120/200 mm²
- Wall plate section: 80/60 mm²
- Outer wall thickness: 365 mm
- Wooden beams are to be secured with a cogging at one end
- The bearing for the wall plates is already prepared

Hand tools

Hammer, hand saw, mortise chisel 24 mm, planing chisel 35 mm, axe

Measuring and testing means

Folding rule, measuring tape, square

Auxiliary accessories

Pencil, piece of board approx. 200 mm long and 120 mm wide (wooden beam width), approx. 4000 mm long lath, approx. 4750 mm long lath, trestles

Necessary previous knowledge

Measuring, scribing, sawing, mortising, plastering

Sequence of operations	Comments
1. Determine the pitch size.	$n'_F = 21$; $T = 594.0$ mm
2. Scribe pitch size on 4000 mm long lath.	Use a measuring tape. Add up the pitch size for scribing (e.g. 594 – 1188 – 1782 – 2376 – 2970 – 3564 (mm)). Scribe square lines.
3. Put four wall plates (quantity for one outer wall) on trestles, scribe a half joint at each end and prepare the half joints, remove the wall plates from the trestles and store them.	Take camber on top. Determine and mark the jointing side. Use a square. Make sure that there is enough room to move.
4. Put four wall plates on trestles and scribe a half joint at one end only, prepare the half joints.	Camber on top. Determine and mark the jointing side. Use a square.
5. Take two wall plates from the trestles and put on and number two of the wall plates worked at first.	I and IV: the wall plates with one half joint each, II and III: the wall plates with two half joints each. Number at the left-hand end.
6. Scribe wall marking on wall plate marked with I.	Scribe at the end with no half joint.
7. Put the lath with scribed pitch size on the wall plate, transfer the pitch size, scribe square lines and provide with jointing mark.	Scribe square lines from front edge to centre of wall plate only.
8. Leave lath on first wall plate, transfer scribed half joint to lath and mark with "1".	Put lath on top side of wall plate. Check faying at wall marking.
9. Scribe beam width on the first wall plate.	Use 120 mm wide piece of board, put it to the square and scribe from front edge to centre of wall plate.

10. Put lath on second wall plate, transfer pitch size, scribe square lines and provide with jointing mark.	Put lath on top side. Pay attention to “1” mark at half joint!
11. Leave lath on wall plate, scribe–mark half joint on lath and mark with “2”.	Check exact faying.
12. Scribe beam width on the second wall plate.	
13. Scribe wall plates III and IV.	Same sequence as per operations 9 to 11.
14. Transfer beam width from front edge of wall plate with square lines downwards and scribe cogging depth on surface of cogging width.	Scribe lines approx. 20 mm long only. Cogging depth approx. 2 cm.
15. Take wall plate from trestles and store it, put on the wall plates for the second outer wall and number them.	V an VIII: wall plates with one half joint each, VI and VII: wall plates with two half joints each.
16. Scribe wall plate similar to the first four ones.	Remove the “1”, “2”, “3” marks from the lath for the pitch size first.
17. Mortise the coggings on all wall plates.	Any order. Make sure that there is enough room to move.
18. Prepare lath (4750 mm long) for scribing of beam lines.	Cut lath to length. Lath length = 2 bearing lengths + clear width of room $L = 2 \cdot 200 \text{ mm} + 4200 \text{ mm}$ <u>$L = 4600 \text{ mm}$</u>
– Scribe length on lath. – Measure–in and scribe bearing length (inner edge of wall).	Mark scribed lines with “section mark”. Measure from “section mark” line to centre of lath. Mark lines with “iew”.
– Measure–in and scribe thickness of plaster base (rear edge of wall plate).	Measure from “iew” line to the end of the lath and mark with “rew” Mark “iew” with void marks!
– Measure–in and scribe wall plate width (front edge of wall plate).	Measure from “rew” line to lath end and mark with “few”.
– Measure–in and scribe cogging width (cogging line).	Measure from “few” line to centre of lath and mark with “cl”. Mark “few” with void mark. Pay attention to cogging width on wall plate.
19. Put five wooden beams on trestles, provide with jointing mark and number them.	Camber to be <u>at bottom!</u> Number at the same beam sides.
20. Put the beams so as to be approximately flush at one end and close together with the longitudinal sides.	Make sure that the jointing marks have the same direction.
21. Scribe square lines over all five beams at the left–hand end and mark with “section mark”.	Scribe section line inwards only as much as to provide all beams with a square section line.
22. Put lath on outer beam and scribe beam section and cogging.	Put lath flush with “section” line. Scribe all valid lines (“rew” and “cl”) of the lath on all five beams. Use a square.

23. Put lath on opposite outer beam and check scribed lines.	Put lath flush with “section” line for checking!
24. Measure–in, angle and scribe cogging depth at both beam sides.	Use a square. Cogging depth approx. 2 cm.
25. Work out the cogging.	
26. Remove beams from the trestles and store them.	Make sure that there is enough room to move!
27. Scribe and prepare the remaining beams, one after the other, according to operations 19. to 26.	Number from VI to XXII.

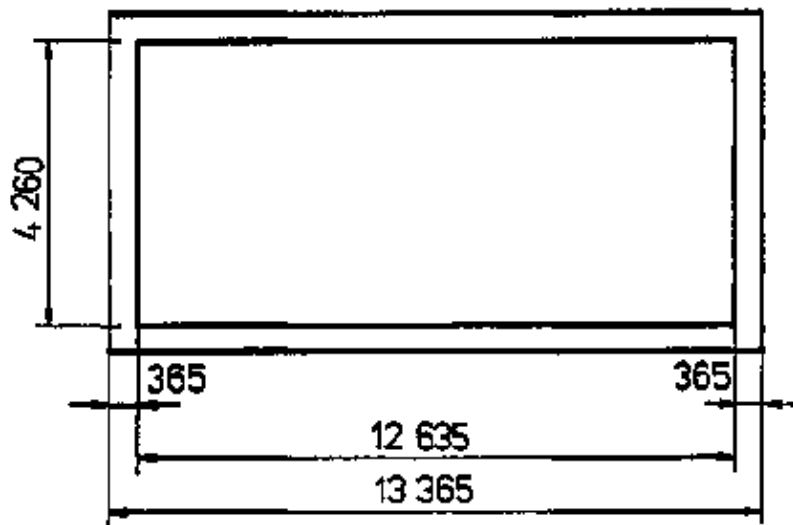
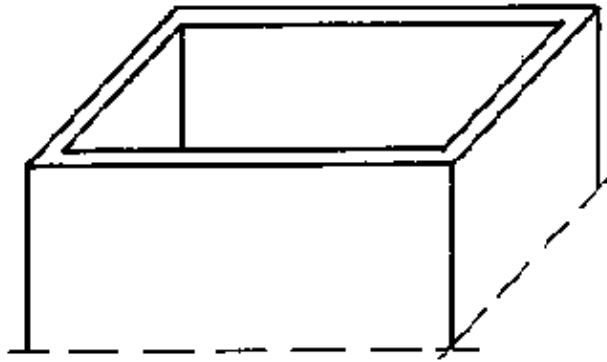

				4.6.
IBE	Wooden beam framing			3604

Wooden beam framing

**Manufacture of Ceilings – Course: Timberwork techniques. Trainees'
handbook of lessons**

Table of Contents

<u>Manufacture of Ceilings – Course: Timberwork techniques. Trainees' handbook of lessons</u>	1
1. <u>Purpose of Ceilings</u>	1
2. <u>The Wooden Beam Ceiling</u>	2
3. <u>The Framing</u>	4
4. <u>The Attic and Collar–beam Framing</u>	9
5. <u>The Pitch Size</u>	11
6. <u>Load on Wooden Beams</u>	13
7. <u>The List of Timber</u>	16
8. <u>The Wall Plate</u>	17
9. <u>Flooring Sleepers</u>	17
10. <u>Special Constructional Recommendations</u>	20

Manufacture of Ceilings – Course: Timberwork techniques. Trainees' handbook of lessons

Institut für berufliche Entwicklung e.V.
Berlin

Original title:
Arbeitsmaterial für den Lernenden
"Herstellen von Deckenkonstruktionen"

Author: Rolf Becher

First Edition © IBE

Institut für berufliche Entwicklung e.V.
Parkstraße 21/23
13187 Berlin

Order No.: 93–35–3604/2

1. Purpose of Ceilings

Ceilings serve architectonic, physical and statical purposes.

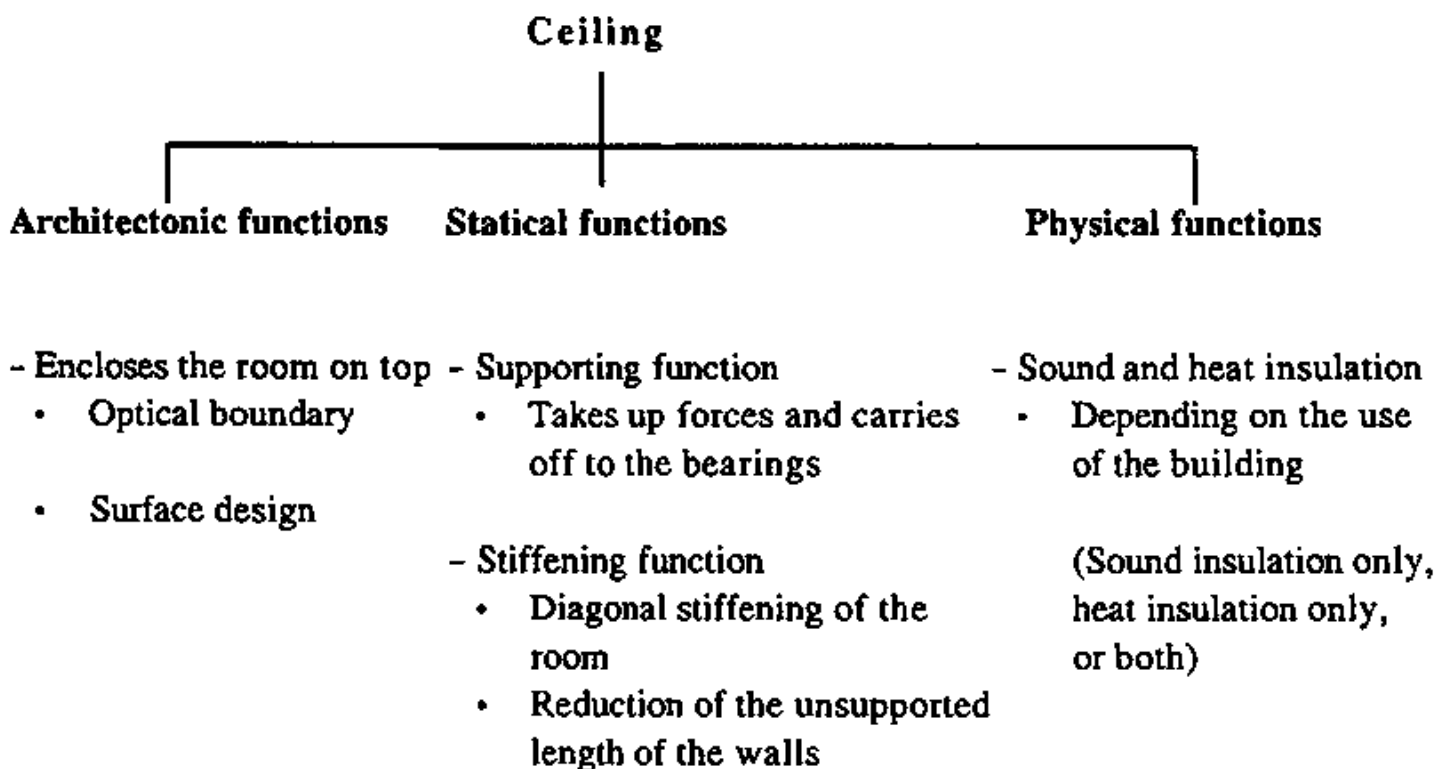

Table 1: Purpose of ceilings

In addition to statical functions, such as stiffening of the building or room and taking up of loads, they should also meet fire-resisting, sound-insulating and heat-insulating requirements. They must withstand the air humidity and, depending on the use of the building, be protected against penetration of moisture.

Basically the construction of a ceiling features three components:

- bare ceiling (supporting and stiffening structure of the ceiling)
- top ceiling (floor construction on the bare ceiling)

– subceiling (covering the bottom side of the bare ceiling).

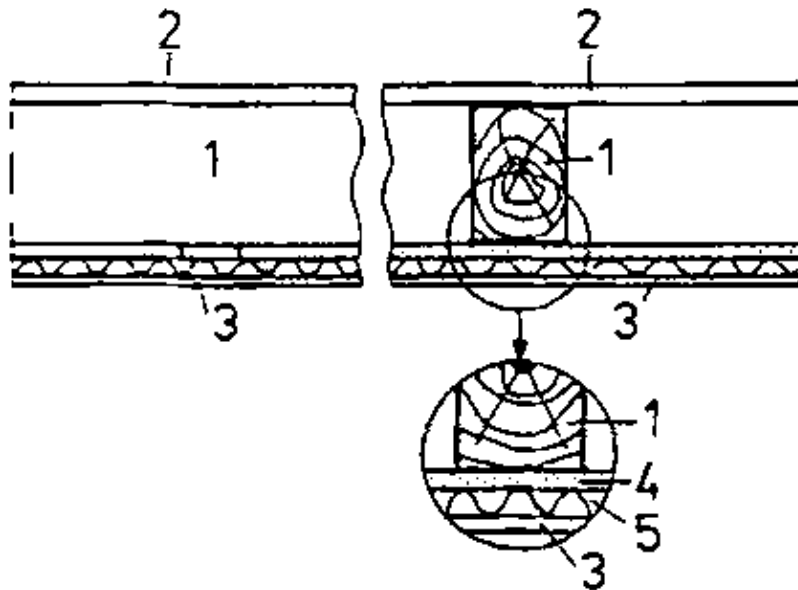

Figure 1

Basic construction of a ceiling

1 bare ceiling (supporting structure), 2 top ceiling, 3 subceiling, 4 additional rafters or thatched ceiling, 5 plaster base (wood-wool boards or woven reed)

The supporting structure of a ceiling may be designed as solid ceiling or as beam (joist) ceiling, depending on the load. The subceiling may also be fixed to the bare ceiling as false ceiling.

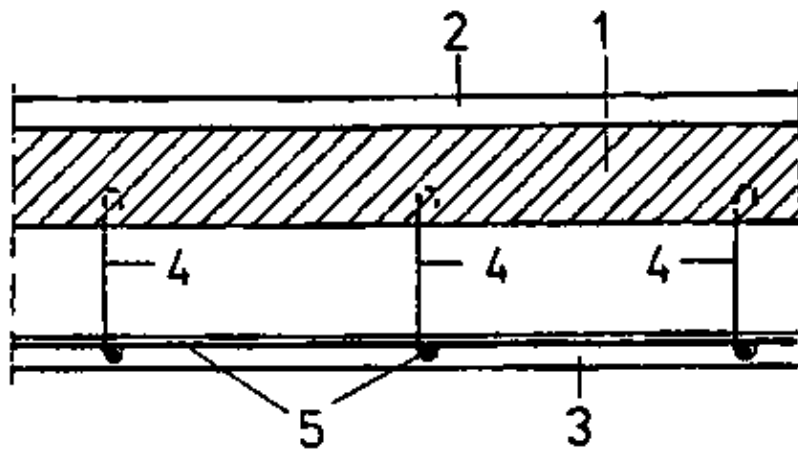

Figure 2

Construction of a false ceiling

1 bare ceiling, 2 top ceiling, 3 false ceiling (stucco ceiling), 4 non-corrosive round steel bars as suspension bars, 5 non-corrosive reinforcing steel bars

2. The Wooden Beam Ceiling

The wooden beam ceiling is a typical beam ceiling.

The supporting structure (the bare ceiling) consists of wooden beams (or joists) placed over a room with a calculated pitch size (spacing).

The infilling (strut members) between the wooden beams depends on the purpose of the building.

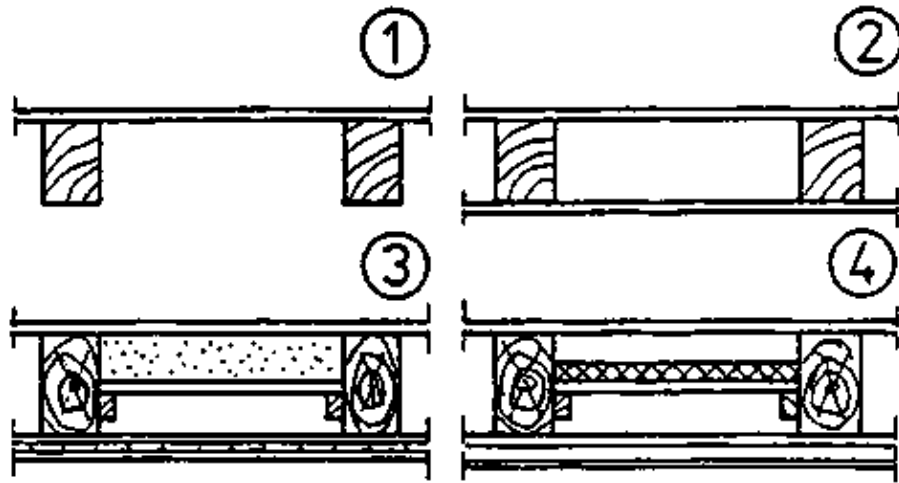

Figure 3

Construction of a wooden beam ceiling, depending on the use of the building

- (1) wooden beam ceiling with top ceiling only
- (2) wooden beam ceiling with top ceiling and subceiling (protection against trickling matter)
- (3) wooden beam ceiling with sound and heat insulation
- (4) wooden beam ceiling with heat insulation only

The infilling of a heat-insulating wooden beam ceiling differs from that of a sound-insulating ceiling.

A wooden beam ceiling, which shall neither be heat-insulating nor sound-insulating, has no infilling at all.

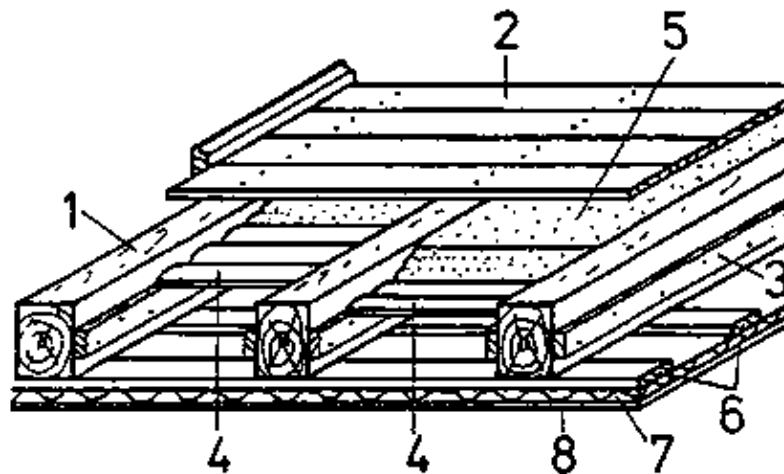

Figure 4

Components of a wooden beam ceiling with infilling

1 wooden beam, 2 (open-nail) flooring, 3 beam strip, 4 dead floor – laggings – (peeled, trimmed slabs; joints filled with clay), 5 slag (sound and heat insulation), 6 additional rafters (distance about 500 mm), 7 woodwool board, 8 ceiling plaster

Figure 4 shows the infilling of a sound-insulating and heat-insulating wooden beam ceiling.

The structural components of bare ceiling, top ceiling and subceiling described therein need not exist with any wooden beam ceiling.

Why need any wooden beam ceiling not consist of such structural components?

Which structural components must any wooden beam ceiling consist of?

If a wooden beam ceiling is to be protected against trickling matter only, the subceiling (protection against trickling matter) may be made of boards planed on one side, of particle board or other material.

Which rooms require protection against trickling matter?

3. The Framing

The wooden beams placed over a room are called (wooden beam) framing. (See Fig. 8)

For easy identification of the individual wooden beams of a framing for a building, they are provided with a "floor mark" and "jointing mark" and numbered with Roman numerals.

Numbering of timbers

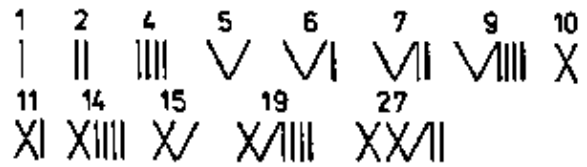

Floor marks

(1st, 2nd, 3rd, 4th... = floor)



Jointing marks

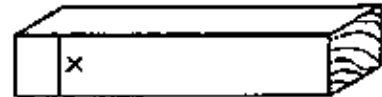

Marking-out mark



centre mark



wall mark



section mark



void mark



meter mark

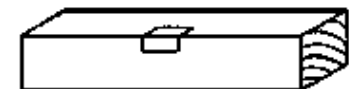

simple cogging

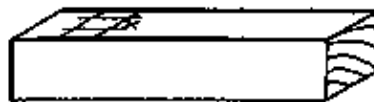

straight

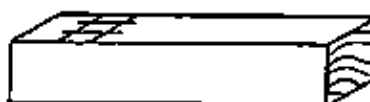

angular tenon

Table 2: Carpenter's marks

The beam marks are cut in by a mortise chisel or done with a pencil.

Marking is always done from the left to the right and from the bottom to the top.

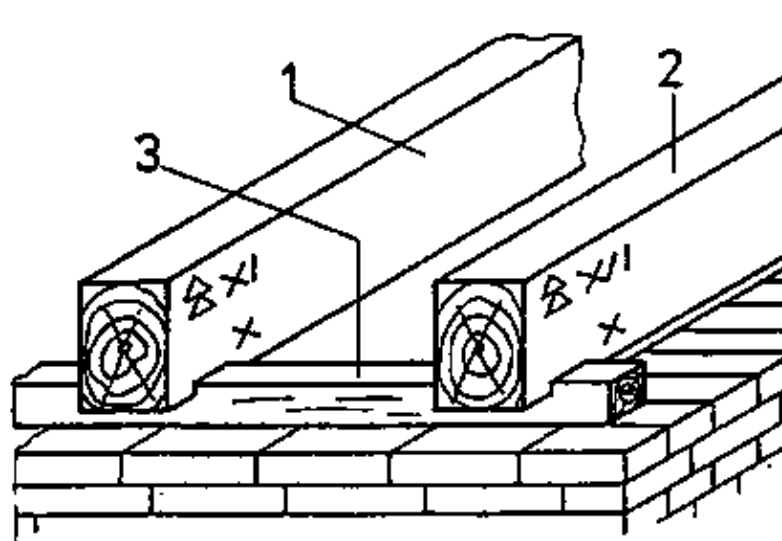

Figure 5

Marking of wooden beams

1 intermediate beam No. 15 in the 2nd floor ceiling,
2 intermediate beam No. 16 in the 2nd floor ceiling,
3 wall plate

The left-hand side always means looking from the front of the building in the plan view.

The wooden beams of one framing may have different widths but they should all have the same height to avoid levelling for the flooring to be provided.

If the beams of one framing are not loaded by concentrated loads (such as a joining beam of an attic framing), they should be placed at equal spacing.

If a wooden beam ceiling is interrupted by openings (such as stairs, chimneys, ventilation ducts), which cannot be located between the clear distances of the beams, a beam trimming will be necessary.

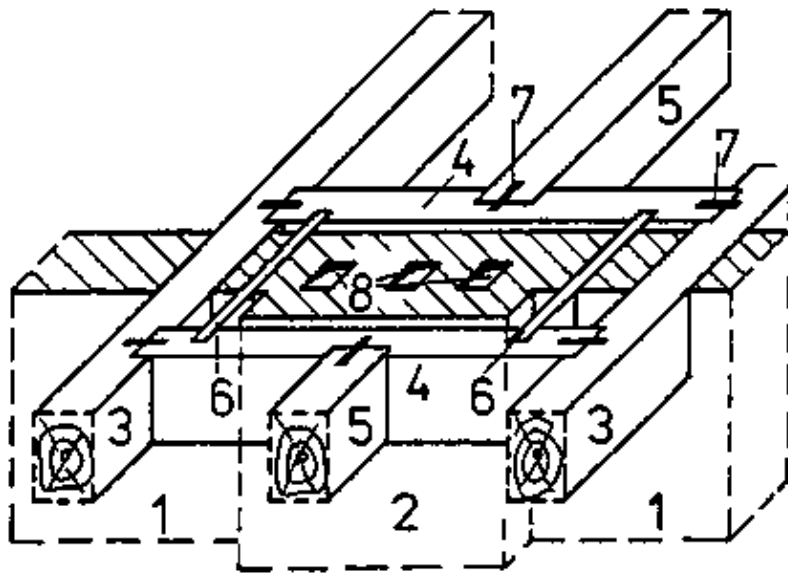

Figure 6

Chimney beam trimming

1 brickwork (centre wall), 2 chimney (three tubes), 3 trimmer beam, 4 beam trimming, 5 tail beam, 6 filling timber, 7 cramp, 8 smoke tube

For chimney beam trimmings a certain distance of the beams from the inner edge of the flue (smoke tube) is to be kept!

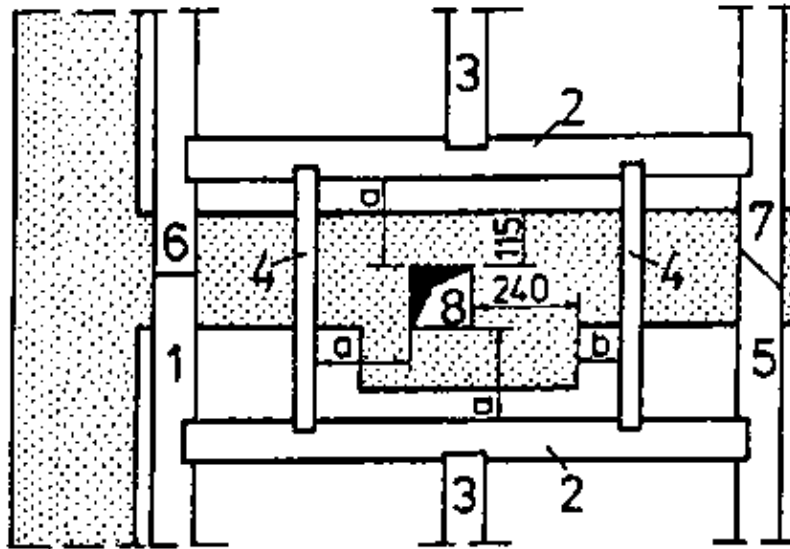

Figure 7

Minimum distances of the beams from the smoke tube

1 passing tail beam, 2 beam trimming, 3 tail beam, 4 filling timber, 5 trimmer beam, 6 joining of timbers by straight joint, 7 joining of timbers by angular joint, 8 smoke tube

a = 200 mm or more

b = 60 mm or more

Why must a certain distance from the smoke tube be kept for chimney trimmings?

Why should all beams of one framing have the same height?

Which distance from the smoke tube must the beams of a chimney trimming have?

The designation of the beams is derived from their location within the framing. From the designation the carpenter tells where to place the respective beam in the framing of the building.

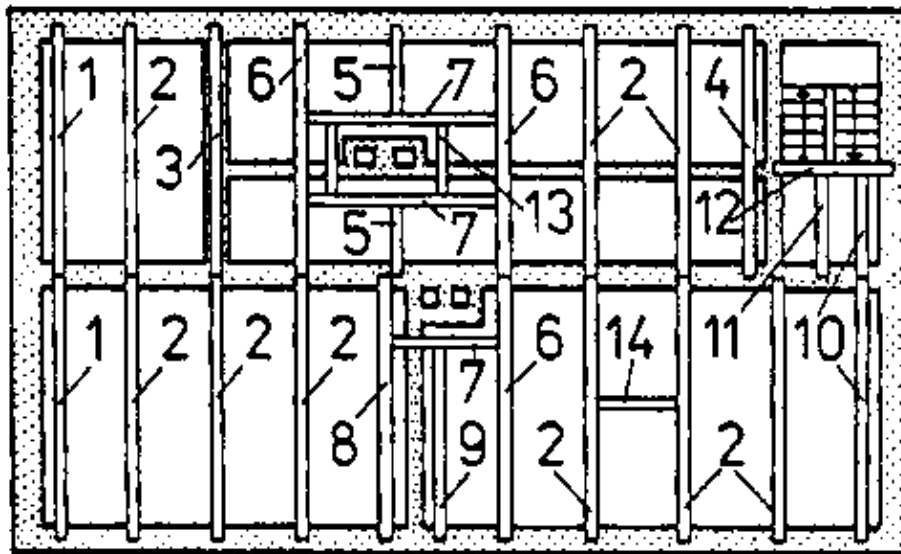

Figure 8

1 Verge or gable beam

- at a distance of 20 mm from the wall and parallel to the gable wall.

2 Intermediate beam

- any beam between the listed beams (1) to (13).

3 Wall beam

- immediately above a wall that is parallel to the straining direction of the beams.

4 Passing beam

- at a distance of 20 mm from a wall which is parallel to the straining direction of the beams.
(The beam is passing along the wall)

5 Tail beam

- parallel to the straining direction of the beams and ending in a beam trimming.
(The beam is tailed into the beam trimming)

6 Trimmer beam

- parallel to the straining direction of the beams and accommodating a beam trimming.

7 Beam trimming

- square to the straining direction of the beams and either ending in a trimmer beam at both ends or resting on a wall at both ends or ending in a trimmer beam at one end and resting on a wall at the other end.

8 Passing trimmer beam

- at a distance of 20 mm from a partition wall and accommodating a beam trimming.

9 Passing tail beam

- at a distance of 20 mm from and parallel to a partition wall and ending in a beam trimming.

10 Verge tail beam for stair landings

- like (1) above, ending in the stair apron.

11 Tail beam for stair landings

- parallel to the straining direction of the beams and ending in the stair apron.

12 Stair apron

- square to the straining direction of the beams and accommodating the tail beams for the stair landing.

13 Filling timber

- square to the beam trimmings and accommodating the flooring within the area of a ceiling opening.

14 Lustre filling timber

- between two beams and square to them, serves for accommodation of a heavy ceiling fitting (lustre).

At which wall must the verge beam be placed?

Which distance from the wall must the passing beam or the verge (gable) beam have?

What is the purpose of the filling timber in a framing?

In order to place the beams of one framing at equal spacing (pitch), the pitch size is to be calculated first.

According to this size, guiding marks are then scribed on the wall plate or directly on the wall and provided with the jointing mark. (See Fig. 10 and Fig. 11).

Working "off the jointing mark" should be given preference over the other two possibilities because the jointing mark remains visible for checking.

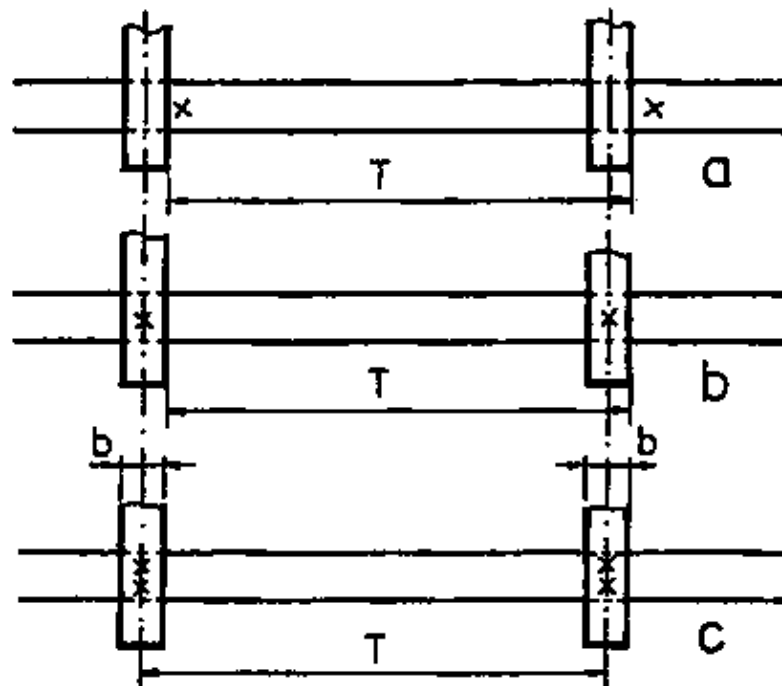

Figure 9

Working with jointing marks

- a** working "off the jointing mark",
- b** width of wooden beam, **c** working "from centre to centre",
- b** working "on the jointing mark", **T** pitch size

Why does the jointing mark remain visible?

What does the term "guiding mark" mean?

4. The Attic and Collar-beam Framing

The attic framing is the top framing.

It supports the roof structure.

All partition walls and the centre wall are ending beneath the attic framing. Fire walls, however, extend until beneath the roofing.

Because the attic framing supports the roof structure, the wooden beams of this framing may have different widths. They all should, however, have the same height!

Why should all wooden beams of the attic framing have the same height?

For equidistant distribution of the beams it is important that the joining beams should not exceed a distance of 4000 mm.

What purpose do the joining beams serve in the attic framing?

It is recommended to fix the location of the joining beams and then to calculate the pitch size for the intermediate beams between them.

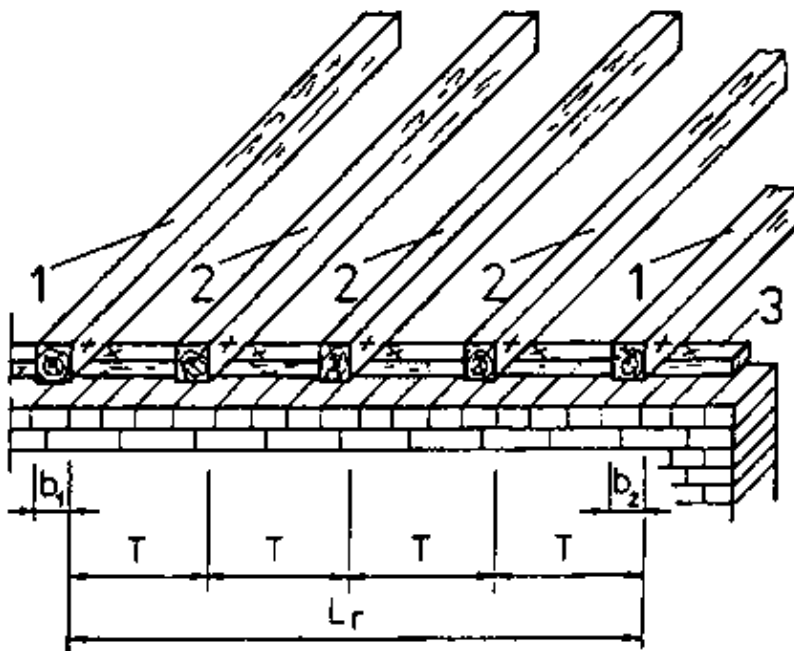

Figure 10

Pitch size between joining beams

1 joining beam, 2 intermediate beam, 3 wall plate, b_1 , b_2 width of wooden beams, T pitch size, L_r arithmetical length for pitch size calculation

The pitch size can be calculated to formula (1) in section 5 hereof. In addition to the floor mark and a number, the joining beams also have a marking-out mark.

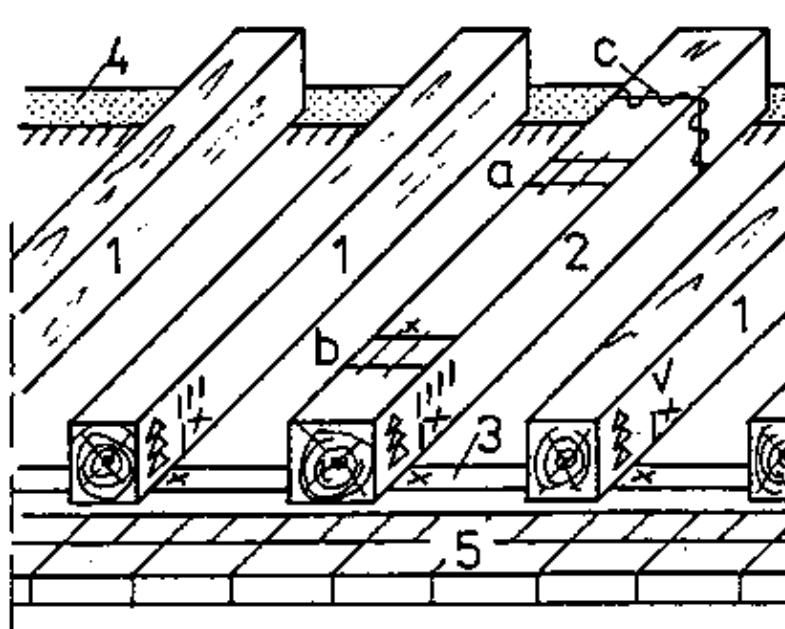

Figure 11

Wooden beams marked with floor mark, jointing mark, number and marking-out marks

*1 intermediate beam, 2 joining beam, 3 wall plate, 4 inner or centre wall, 5 outer wall
a marking-out mark for straight tenons, b marking-out mark for angular tenons, c void mark*

Why do the wooden beams of a framing have a number and a floor mark?

What are marking-out marks?

The collar-beam framing is no typical wooden beam framing. It is mainly applied in a rafter roof. The purpose of the collar beams is to stiffen the rafter pair of a rafter roof.

But collar beams may also be built into a purlin roof when the roof room is very high and shall be used effectively.

5. The Pitch Size

The wooden beams of a wooden beam ceiling should be placed at equal distances so as to equally distribute the load on all beams.

If the distances between the wooden beams are not shown in the drawing, the pitch size is to be calculated.

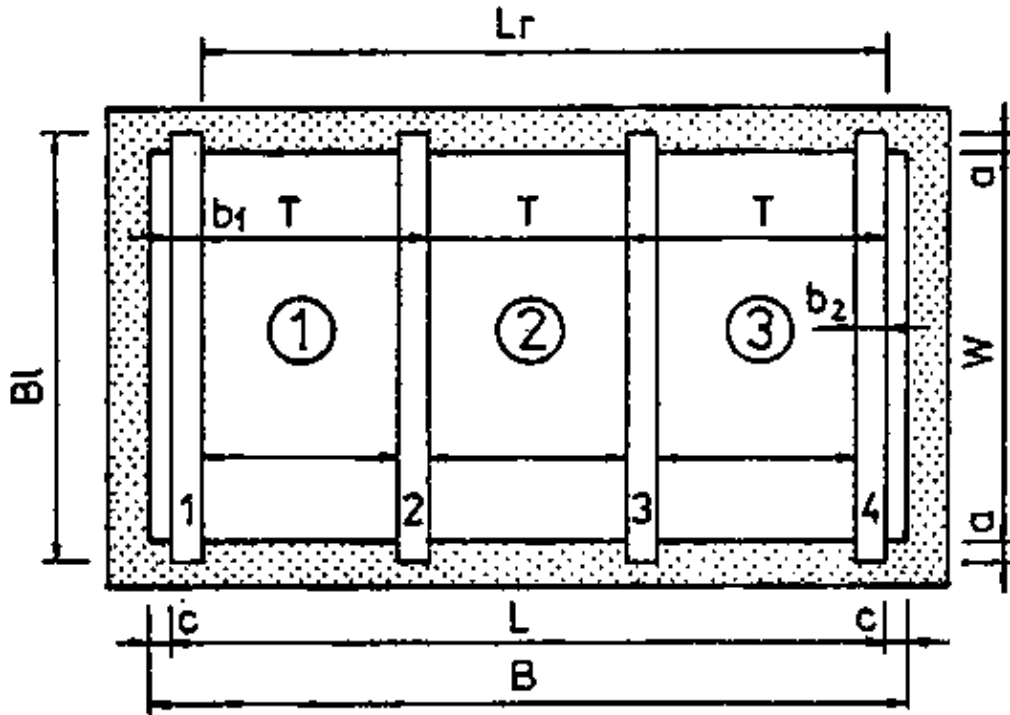

Figure 12

Determination of the pitch size

(1) bay 1, (2) bay 2, (3) bay 3

L_r length required for the calculation, BL length of wooden beam, T pitch size (beam spacing), B clear width of the room, L length to be distributed, a bearing length, b_1, b_2 width of wooden beams, c minimum distance of wooden beams from the wall, 1, 2, 3, 4 wooden beams

The pitch size depends on the thickness of the flooring and is calculated to formula (1).

$$T = \frac{L_r}{n'_F} \quad (1)$$

T = pitch size (distance of wooden beams)
 L_r = length required for the calculation
 n'_F = number of bays

The number of bays is determined by means of formula (2).

$$nF = \frac{L_r}{T_{zul}} \quad (2)$$

T_{zul} = pitch size depending on the thickness of the flooring

20 mm thick flooring – – – pitch size $T_{zul} = 600$ mm

24 mm thick flooring – – – pitch size $T_{zul} = 800$ mm

30 mm thick flooring – – – pitch size $T_{zul} = 1000$ mm

If the resulting n_F is a decimal fraction, it is to be rounded off to bring it up to the next integer number.

The rounded-off number of bays is provided with a superscript mark for identification.

For example: $n_F = 6.4$; $n'_F = 7$

The length to be distributed is determined by deducting the wooden beams' minimum distance from the wall at both ends from the clear width of the room.

$$L = B - 2c \quad (3)$$

L = length to be distributed

B = clear width of the room

c = minimum distance of the wooden beams from the wall, normally 20 mm

For the calculation of the pitch size, the arithmetical length is required. It results from formula (4):

$$L_r = L - \frac{b_1 + b_2}{2} \quad (4)$$

b = wooden beam width

Formula (5) gives the number of wooden beams to be placed over a calculated distance:

$$n_B = n'_F + 1 \quad (5)$$

The length of the wooden beams is calculated to formula (6):

$$BL = w + 2a \quad (6)$$

BL = length of wooden beam

w = clear width of the room

(in straining direction of the beams)

a = bearing length

(a = at least 150 mm)

Why should the wooden beams have equal distances?

Why should the wooden beams have equal distances?

Why must the wooden beams have a distance of a least 20 mm from the wall?

What does the formula $n_B = n'_F + 1$ say?

Why must n_F be rounded off to the next integer number?

6. Load on Wooden Beams

The wooden beams of one framing cannot be loaded by loads of any quantity.

Why can the wooden beams not be loaded by loads of any quantity?

For the loading of such ceilings a continuous surface load is assumed. The basis in housing construction is a working load of 2.0 kN/m².

Such load is reached in exceptional cases only. It would mean that about 48 persons would stay at the same time on a wooden beam ceiling of a room with an area of 16 m² (about 0.75 kN/person).

When the wooden beam ceiling is loaded, the wooden beams deflect. Such deflection will always occur with loads but it must not exceed 1/300 of the span.

The uniformly distributed, allowable (safe) load on a wooden beam ceiling, with due consideration to the deflection of the wooden beams, is determined through the moment of inertia.

The table for cross sections of wooden beams shows sections for coniferous wood (NH) of grade II (Gk II) for clear widths of rooms (w) from 2.0 m to 5.0 m as well as for distances of wooden beams of 600 mm, 800 mm and 1000 mm.

The sections of the wooden beams refer to a total load (dead load and working load of the wooden beam ceiling) of 4.0 kN/m².

Table 3: Table for cross sections of wooden beams

This table shows cross sections of wooden beams (NH, Gk II) for a load of 4.0 kN/m². (dead load = 2.0 kN/m², working load = 2.0 kN/m²)

The dead load of the wooden beam ceiling corresponds to that of a heat and sound-insulating ceiling.

Clear width of room	Distances of wooden beams		
	600 mm	800 mm	1000 mm
in mm w	b/h in cm ²	b/h in cm ²	b/h in cm ²
2000	6/12	8/12	10/12
2100	8/12	10/12	12/12
2200	8/12	10/12	10/14
2300	10/12	12/12	10/14
2400	12/12	8/14	12/14
2500	12/12	10/14	14/14
2600	10/14	10/14	14/14
2700	10/14	12/14	12/16
2800	12/14	12/14	12/16
2900	12/14	14/14	14/16
3000	14/14	10/16	16/16
3100	10/16	12/16	16/16
3200	12/16	14/16	14/18
3300	12/16	14/16	14/18

3400	14/16	16/16	16/18
3500	14/16	16/16	16/18
3600	16/16	14/18	18/18
3700	16/16	14/18	14/20
3800	14/18	16/18	16/20
3900	14/18	16/18	14/22
4000	16/18	18/18	14/22
4100	16/18	18/18	16/22
4200	12/20	14/20	16/22
4300	14/20	16/20	18/22
4400	14/20	18/20	18/22
4500	16/20	18/20	18/22
4600	16/20	20/20	20/22
4700	14/22	20/20	22/22
4800	14/22	16/22	18/24
4900	16/22	18/22	^0/24
5000	16/22	18/22	20/24

Coniferous wood (NH), such as spruce, pine wood grade II (Gk II) means:

- wood free from wood pest,
- wood with knots having a diameter of less than 1/3 of the wood width but not exceeding 70 mm,
- the sum of all knot diameters over 150 mm wood length per area of cut must not exceed 2/3 of the wood width.

If the cross sections of wooden beams shown in the table are not in stock, other sections may be used.

Other cross sections, however, would mean to calculate them through the section modulus.

Assuming that wooden beams are mainly used with rectangular section, the small face is always used as bearing surface.

If the width of the beam shall be changed, the height of the beam must be changed, too.

The section modulus for wooden beam sections is calculated by means of the formula:

$$W_x = \frac{b \cdot h^2}{6}$$

W = section modulus referred to the x axis
b = width of the wooden beam
h = height of the wooden beam

If the height of the beam shall remain unchanged, the formula is to be converted to give b as follows:

$$b = \frac{6W_x}{h^2}$$

If the width of the beam shall remain unchanged, the formula is to be converted to give **h** as follows:

$$h = \sqrt{\frac{6W_x}{b}}$$

If the result is a decimal fraction, it is to be rounded off to the next greater size of wooden beams.

For example:

b = 13.4 cm --- b = 14 cm
 b = 14.1 cm --- b = 16 cm
 h = 21.5 cm --- h = 22 cm
 h = 20.5 cm --- h = 22 cm

7. The List of Timber

The wooden beams of one wooden beam framing must be ordered and supplied exactly to the wooden beam section and wooden beam length.

Why can the wooden beams not be ordered and supplied in m³?

For better clearness of the order, a list of timber is used. (See Table 4)

Table 4: Example for a list of timber for the 2nd floor framing

No.	Pos.	Designation	Cross section mm/mm	Individual length mm	m ace. to cross section			
					100	120	140	160
1	2	verge beam	140/200	5400			10.80	
2	10	intermediate beam	160/200	5400				54.00
3	2	passing beam	120/200	5400		10.80		
4	2	tail beam	160/200	2310				4.62
5	2	beam trimming	160/200	1600				3.20
6	1	filling timber	100/200	800	0.80			
Total length in m 3 % waste					0.80	10.80	10.80	61.82
					0.02	0.32	0.32	1.85
Total length and waste					0.82	11.12	11.12	63.82
Volume in m ³					0.02	0.27	0.32	2.04
Total volume in m ³						2.65		

8. The Wall Plate

Actually the wall plate is not a plate but a rectangular timber. The purpose of the wall plate is to accommodate the wooden beams of a framing, to ensure a uniform bearing height and to better distribute the bearing force over the bearing.

A rectangular timber with a cross section of $b/h = 100/80 \text{ mm}^2$ or $80/60 \text{ mm}^2$ is used as wall plate.

Is the wide or small face of the rectangular timber used as bearing surface of the wall plate?

In order to prevent axial or lateral displacement of the wooden beams, the beams are cogged in the wall plate or are secured by means of a pin connection.

The wall plate is mainly necessary in brickwork construction. On a 240 mm thick wall, the wall plate is to be mounted flush with the inner wall line.

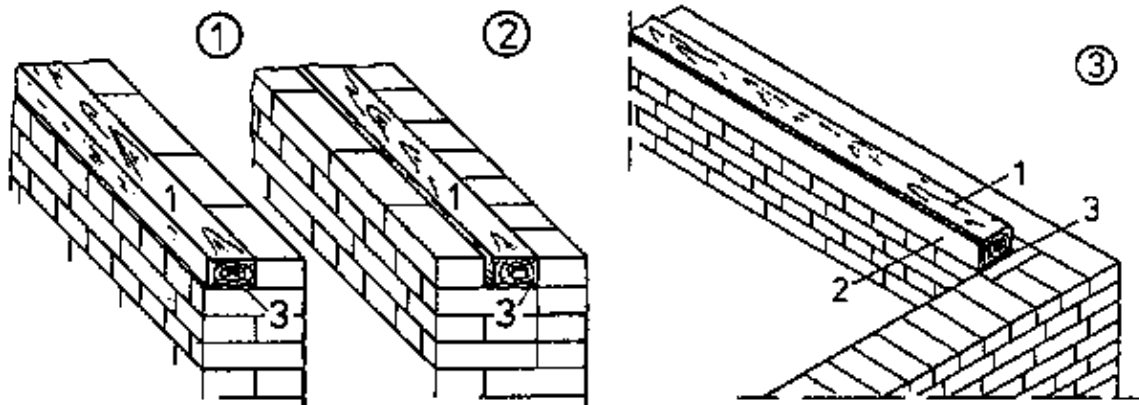

Figure 13

- (1) wall plate mounted flush with the inner wall line
 - (2) wall plate displaced to the centre of the wall
 - (3) wall plate mounted flush with the inner wall line and provided with plaster base
- 1 wall plate, 2 plaster base (wood-wool board), 3 barrier layer under the wall plate

Why is the wall plate to be mounted flush with the wall line?

On a 365 mm thick or thicker wall, the wall plate may be displaced towards the centre of the wall, i. e. it is to be displaced inwards as much as to leave enough room for the wall plate to be faced with a plaster base.

Why must the wall plate be faced with a plaster base?

Sling fabric or Rabitz fabric may be used as plaster base for flush-mounted wall plates. A strip of woodwool wall board may be used as plaster base for non-flush wall plates.

9. Flooring Sleepers

If a solid ceiling is to be provided with batten floor as top ceiling, flooring sleepers are required for fixing the battens.

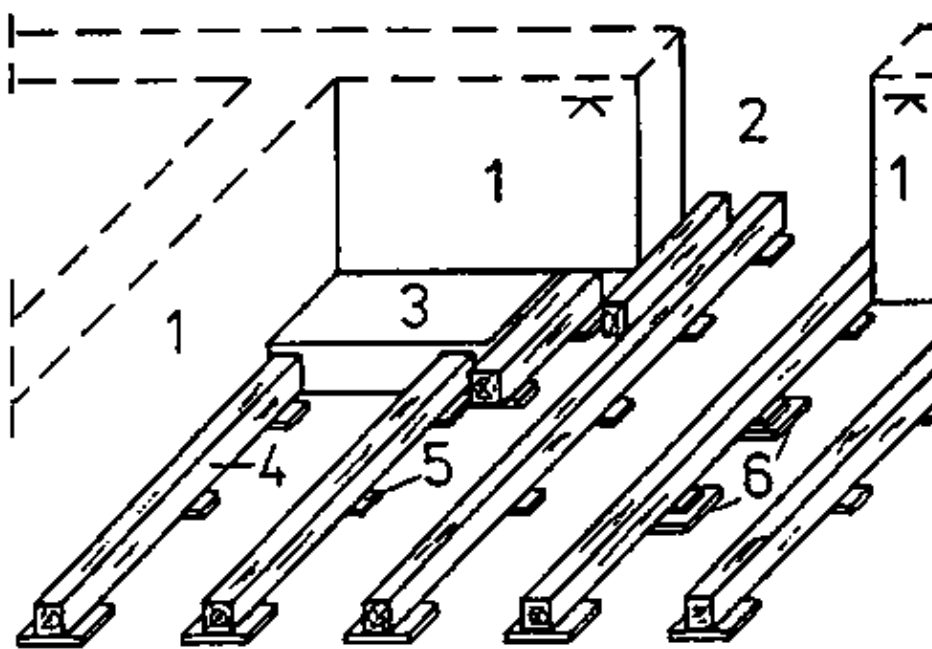

Figure 14

Flooring sleepers on solid ceiling

1 brickwork with metre mark, 2 door opening, 3 stove foundation, 4 flooring sleeper, 5 packing at the bottom (substructure), 6 barrier cardboard

The flooring sleepers take over the function of the wooden beams and are also placed according to the pitch size.

Why must the wooden beams or flooring sleepers be placed according to a calculated pitch size?

The timbers used as flooring sleepers should be sound, peeled, parallel trimmed at two sides, preferably treated with wood preservative and have a height of at least 100 mm.

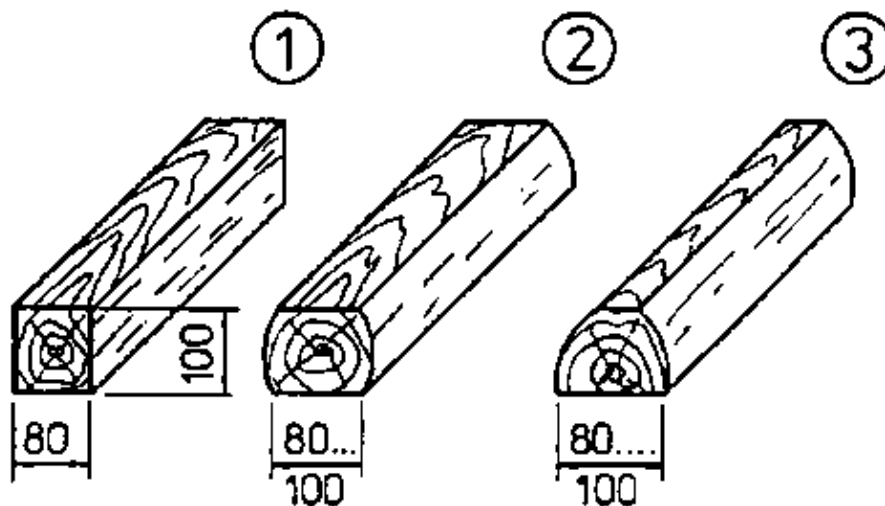

Figure 15

Cross sections of flooring sleepers

- (1) square sleeper
- (2) sleeper parallel cut at two sides, symmetrical
- (3) sleeper parallel cut at two sides, asymmetrical

The wide face of the flooring sleepers is to be used as bearing surface so as to ensure good and immovable bearing. This is of special importance if slag is to be placed between the flooring sleepers as sound and heat-insulating material.

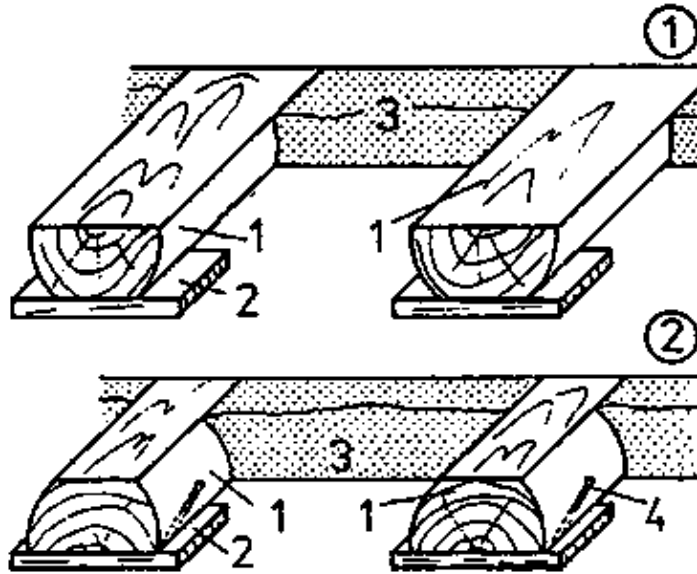

Figure 16

Functional position of flooring sleepers

- (1) wrong position
- (2) correct position

1 sleepers, 2 substructure (packing at bottom), 3 slag, 4 pin nail

What would happen to the flooring sleepers when the slag is placed and compacted, if this is not taken into account?

The substructure (packing at the bottom) of the sleepers consists of hardwood wedges or other material.

The top surface of the sleepers is to be exactly levelled by means of a level board.

The substructure is to be secured against displacement by pins. A barrier layer (barrier cardboard) is to be placed between the solid ceiling and sleepers or wooden substructure, respectively.

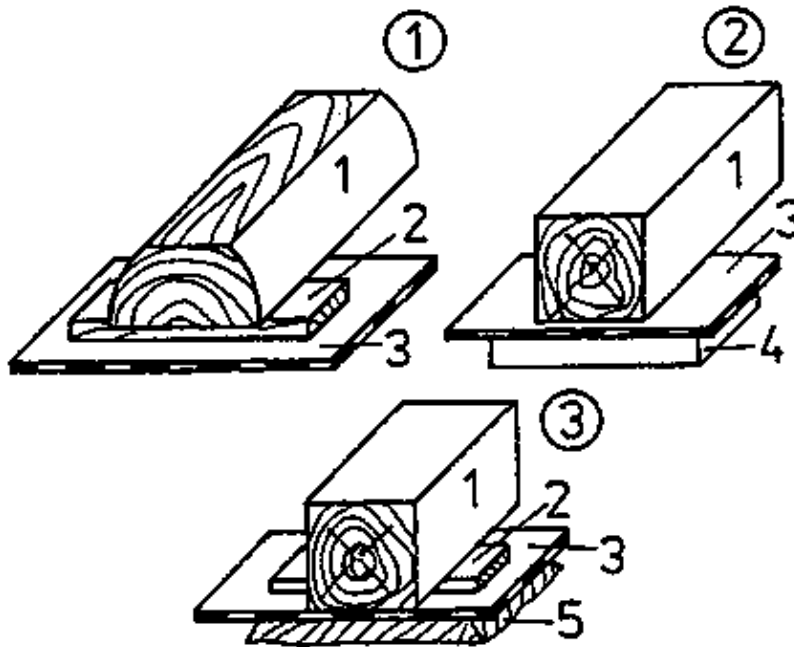

Figure 17

Substructure of flooring sleepers

- (1) wooden packing
- (2) stone-slab packing
- (3) packing by even bed of mortar

Why is a barrier layer to be placed?

10. Special Constructional Recommendations

Sound and heat insulation in ceilings

- If ceilings are to be provided with sound or heat insulation or both, the hollow space between verge (gable) beam and gable wall or between passing beam and partition wall, respectively, is to be filled with moisture-resistant material.
- The gap between the jamb of flue and filling timber or beam trimming, respectively, is to be filled with non-flammable material.
- If mineral wool mats or textile fibre mats are used, they are to be fixed to the wooden beams by wooden strips.
- If insulating mats are to be joined, they must be overlapped sufficiently.

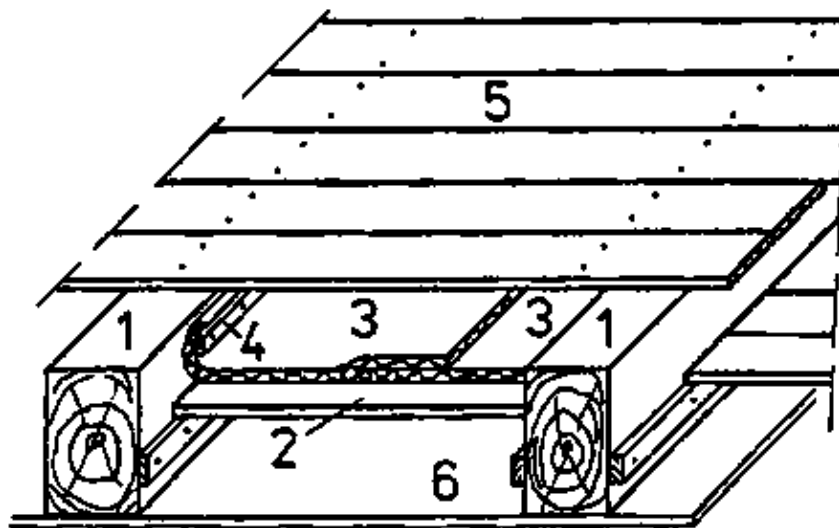

Figure 18

Wooden beam ceiling with heat insulation only

1 wooden beams, 2 dead floor (laggings), 3 heat-insulating mat, 4 wooden strip to fix the insulating mats, 5 flooring, 6 protection against trickling matter (particle board)

- If slag is used for footfall sound insulation, the slag is to be placed as high as to provide good supporting contact for the blind side of the floor battens.
- Dry material only must be used for sound and heat insulation.
- If heat insulation is required for the outside wall, heat-insulating material is to be placed at the respective crossgrained end of the wooden beam.

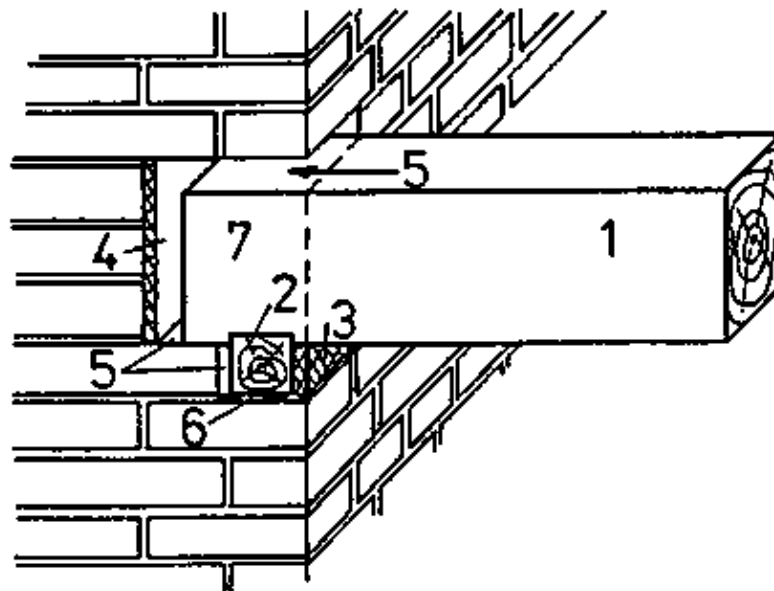

Figure 19

Heat insulation in the area of the beam head

1 wooden beam, 2 wall plate, 3 plaster base, 4 heat-insulating material, 5 air gap, 6 barrier layer, 7 beam head

Connection between brickwork and wood

- All wooden parts, which are fixed in the wall, must be protected against the moisture in the brickwork.

- The wall plate is fixed in the wall “dry”, i. e. the bricks are laid without mortar in a distance of 1 cm from the wall plate.

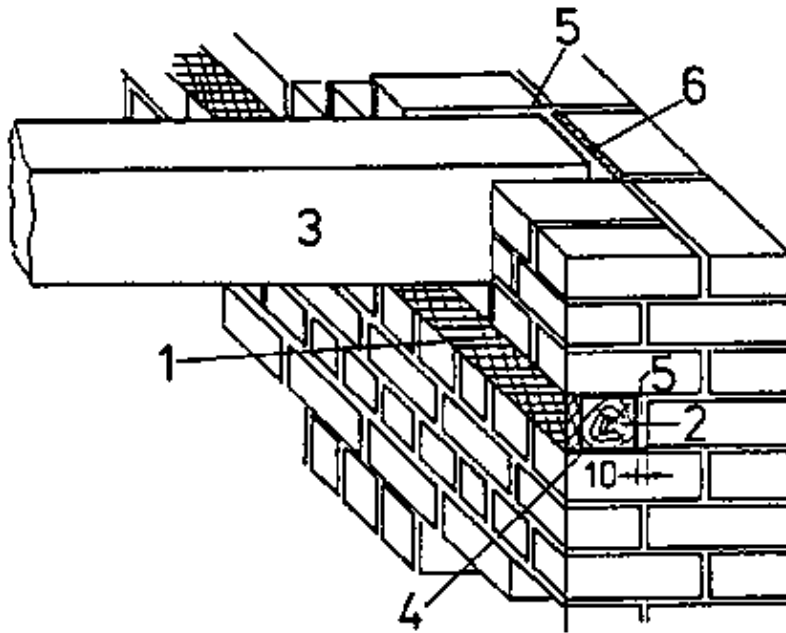

Figure 20

Wall plate fixed in the wall

1 plaster base, 2 wall plate (fixed dry), 3 wooden beam, 4 barrier layer, 5 air gap, 6 heat-insulating material

- An air gap of about 1 cm is to be left around the head of the beam.
- At the face end of the head of the beam, an air gap of 2 cm is to be left (See Fig. 19).
- On the wall plate and on the head of the beam, the bricks are to be laid without mortar (dry).
- The air gap around the head of the beam must not be filled with plaster mortar.

Tieing of the wooden beams

Ceilings must stiffen the building or room.

For this purpose the wooden beams are tied to the outer walls.

In the longitudinal walls (walls accomodating the wooden beams) every third wooden beam is provided with a beam tie.

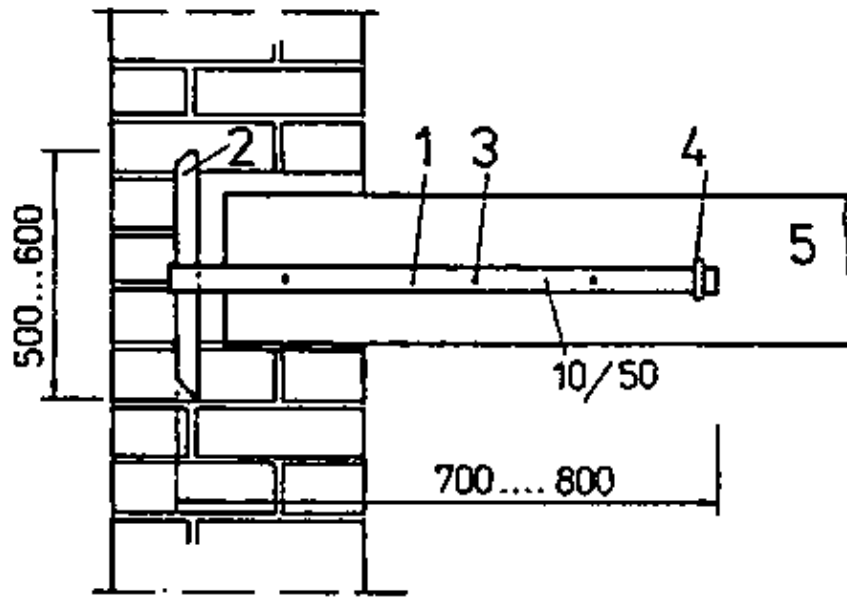

Figure 21

Beam tie as head tie

1 beam tie, 2 cotter pin, 3 screw or forged nail, 4 clamp, 5 wooden beam

The gable walls are secured by gable ties.

Gable ties must extend over at least three wooden beams.

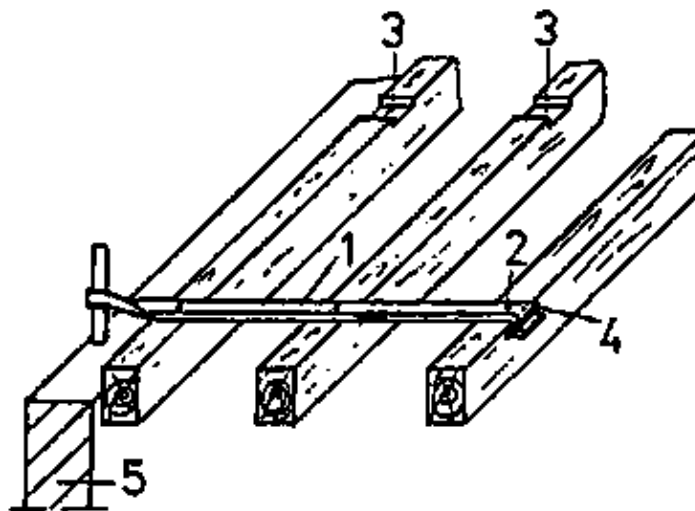

Figure 22

Beam tie as gable tie

1 gable tie, 2 screw or forged nail, 3 recess for gable tie, 4 clamp, 5 brickwork

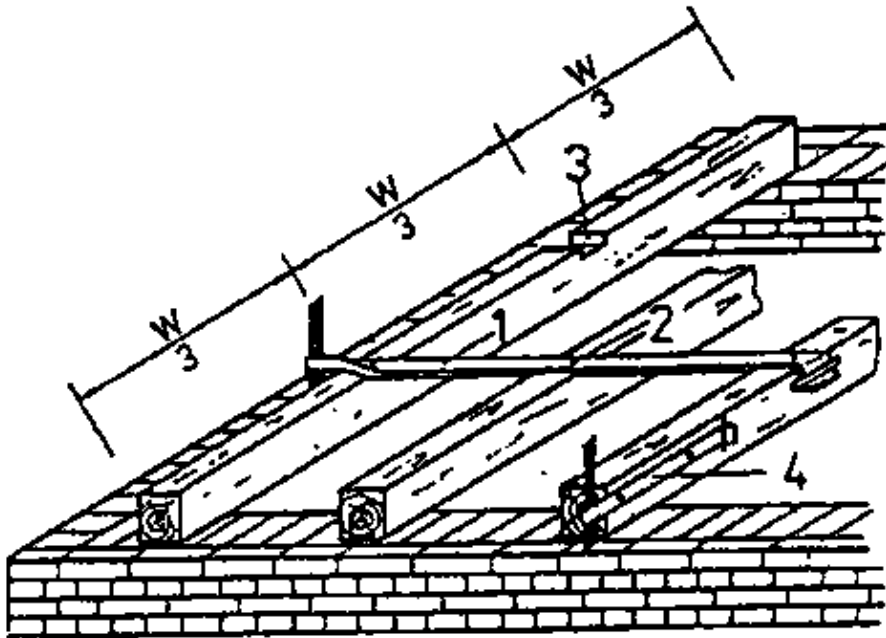

Figure 23

Distribution of gable ties

1 gable tie, 2 screw, 3 recess, 4 head tie, w clear width of the room

They are arranged in the third points of the wooden beams.

The inner edge of the cotter pin should have a distance of 240 mm to the inner edge of the wall.

The gable ties should be placed in a recess in the wooden beams. Screws or forged nails are to be used for fixing the beam ties or gable ties!

Additionally they are to be secured by cramps to be placed before the upward edge-bend.

Making of Floors – Course: Timberwork techniques. Instruction examples for practical vocational training

Table of Contents

<u>Making of Floors – Course: Timberwork techniques. Instruction examples for practical vocational training</u>	1
<u>Preliminary Remarks</u>	1
<u>Instruction Example 6.1.: Checking and Levelling of the Beams</u>	1
<u>Instruction Example 6.2.: Laying of Mated Surfaced Deals</u>	5
<u>Instruction Example 6.3.: Laying of Matched Surfaced Deals</u>	9
<u>Instruction Example 6.4.: Fixing of Skirting Boards</u>	12

Making of Floors – Course: Timberwork techniques. Instruction examples for practical vocational training

Institut für berufliche Entwicklung e.V.
Berlin

Original title:
Lehrbeispiele für die berufspraktische Ausbildung
“Herstellen von Fußböden”

Author: Horst Hofmann

First Edition © IBE

Institut für berufliche Entwicklung e.V.
Parkstraße 21/23
13187 Berlin

Order No.: 93–33–3606/2

Preliminary Remarks

The present material includes 4 selected instruction examples on the basis of which the essential sequences of operations with the laying of surfaced deals can be demonstrated with increasing degree of difficulty.

Skills as sawing, nailing, chopping, cutting and planing are explained.

It is recommended to begin with simple mated boarding in secondary buildings. Here, the required knowledge can be acquired and extended and consolidated later when other types of wooden floors are dealt with.

In order to facilitate the preparation and carrying out of the work, the required materials, tools and auxiliary accessories are indicated for each instruction example.

Furthermore, the basic knowledge is mentioned which is required for laying surfaced boards and which had already been imparted before.

It is recommended to repeat this previously acquired knowledge before starting the work. The process of working and the quality of work has to be constantly supervised and controlled by the instructor.

To each instruction example a working drawing is attached which will contribute to a better understanding of some techniques and auxiliary means, as well as of the sequence of operations.

Instruction Example 6.1.: Checking and Levelling of the Beams

In the course of this exercise the beams are checked for equal height and horizontal position, and uneven surfaces are smoothed.

Material

– Boards

Thickness: 1–15 mm, also with wedge-shaped ends
Width: Same as the beams

– Nails

Length: approximately 40 – 60 mm

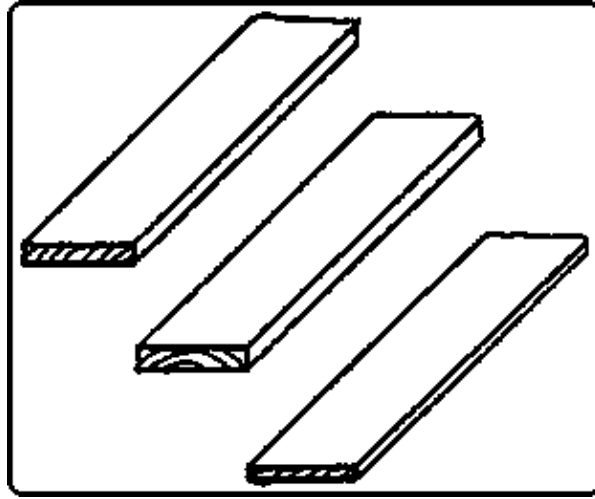

Tools

Hand saw, hammer, axe, plane

Measuring and testing means

Folding rule, water-level, level board (a straight, parallel, long plank)

Auxiliary accessories

Trestles for supporting the material during working

Required basic knowledge

Testing, measuring, sawing, chopping, planing, nailing

Sequence of operations	Comments
1. Arranging the workshop place, preparing materials and tools.	Check the tools for their completeness and serviceability.
2. Putting the level board across the beams along the wall, checking the beams as to equal height and, by using the water-level, to horizontal position.	Test the accuracy of the water-level before.
3. If the height is equal and the beams are horizontal, putting the level board lengthwise on a wall beam and checking horizontal position.	Make sure that the level board rests completely on the beam over its total length, if necessary, remove cuttings and the like.
4. If this horizontal line is guaranteed, too, putting the level board along the other wall across the beams and checking. If all beams are in horizontal position and of equal height, laying of the deals can be started.	If the beams were laid accurately, levelling of them before laying wooden floors is hardly necessary.
5. If the layer of beams is uneven, finding out the highest beam. Examining it in longitudinal direction and, if required, levelling it horizontally.	
6. Transmitting the height of this beam to the beams along the wall, levelling these horizontally according to the given height.	The heighest point may also be a wall beam; in this case level this and transmit its height to the opposite wall beam.
7. Then putting level board across the beams which are now horizontal and levelling the height of all beams in between.	Levelling is made by nailing boards on the beams the thickness of which equalizes the difference.

	<p>The beams are adapted in height over their full surface. Chop the boards to the required thickness – also with wedge-shaped ends – plane them or cut them with the help of a circular saw bench.</p>
8. Final checking.	

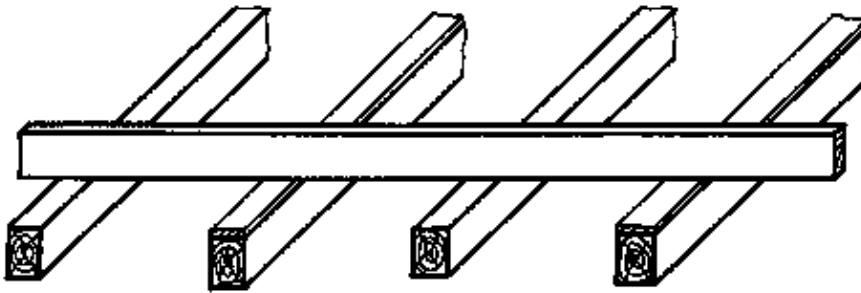
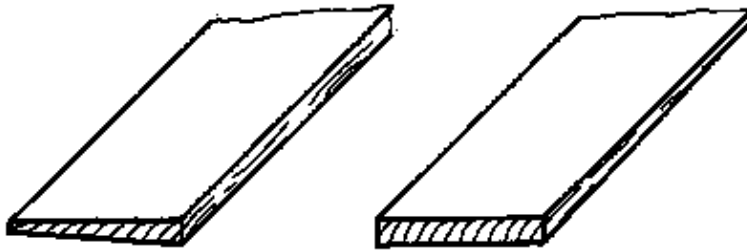
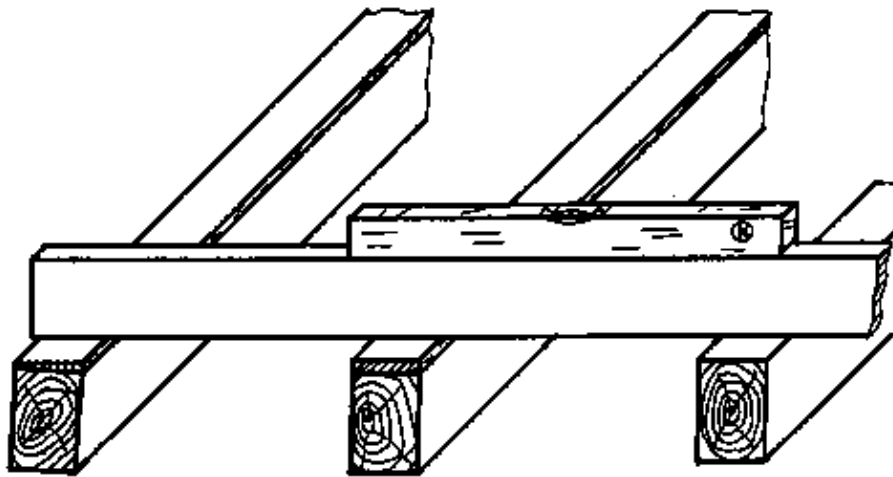

				6.1.
IBE	Beams (naked flooring)			3606

Beams (naked flooring)

Instruction Example 6.2.: Laying of Mated Surfaced Deals

In this instruction example the laying of mated surfaced deals is practised – a technique which is applied in buildings of secondary importance, such as sheds, lofts etc.

Material

– Surfaced deals, mated

Thickness: 24 mm
Width: 120–160 mm
Length: 4000 mm

– Countersunk head nails

Thickness: 3.1 mm
Length: 70 mm

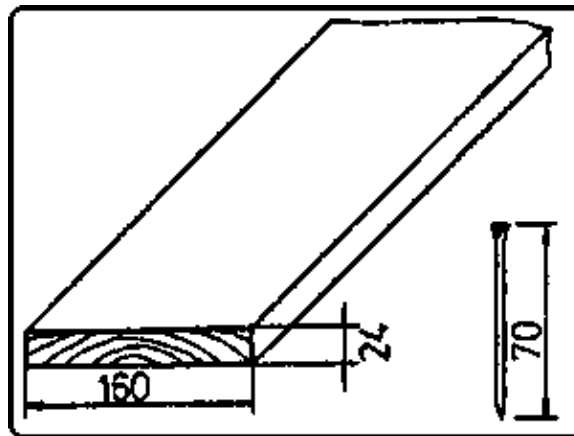

Tools

Hand saw with a tooth form suited for cross cuts, hammer, axe, plane, chisel, nail punch

Measuring and testing means

Folding rule, pencil, flat or try square

Auxiliary accessories

Trestles approximately 600 mm high, deal cramps or steel cramps, wooden wedges and pieces of planks

Required basic knowledge

Measuring, sawing, chopping, planing, nailing

Sequence of operations	Comments
1. Arranging the workshop place, putting the trestles for supporting the deals in place, preparing materials and tools.	Check the tools for completeness, test the keenness of the cutting tools.–
2. Measuring the room at several points across the beams.	Check whether or not all the lengths measured are the same.
3. Transmitting the determined length, less 10 –15 mm for an edge strip, on the deals.	If the deals have. the length of the room, 10–15 mm are deducted from the left and right end each for edge strips.

<p>4. Putting a square to the marking of the length, scribing and sawing to length with the hand saw.</p>	<p>If a number of deals shall be cut to the same length, they may also be put one upon the other and sawn at a time. The square can be put on the pile of deals and an additional vertical marking-out line be drawn.</p>
<p>5. Laying the first deal 10 – 15 mm distant from the wall and nailing it with two nails on each beam.</p>	
<p>6. Starting from the fixed deal five to six deals are put closely together.</p>	<p>The number depends also on the quality of the boards.</p>
<p>7. Driving a steel cramp in two to three beams at a distance of 100 – 150 mm from the deals laid, putting a piece of a plank and two wooden wedges between the deals and each cramp, tightening the wedges alternatively and evenly with the hammer this way pressing the deals together.</p>	<p>Wooden wedges are put one above the other only by their tips.</p>
<p>8. Drawing a thin line with lead pencil on the deals – middle of the beam – and nailing the deals from the front – cramps – to the rear.</p>	<p>Do not use a copying-pencil. The steps of work from point 6 to point 8 have to be done repeatedly.</p>
<p>9. For laying the last three deals measuring the space between the deals already laid and the wall, deducting the width of two deals and 15 mm for an edge strip from this measure, preparing the third deal according to the required size, then putting the deals in place. Pressing them together by driving wooden wedges between deal and wall and nailing them.</p>	<p>The last deal must be sawn off or chopped according to the required width and planed. In order to protect the plaster of the wall against damages, put a piece of a plank between the wooden wedge and the wall.</p>
<p>10. Driving in all nails two to three mm into the surface of the deals with a nail punch.</p>	
<p>11. Cleaning the deals and removing superfluous material from butts or joints with a plane.</p>	<p>Before planing make sure that all nails are counter-sunk. By smoothing a uniform and even surface is achieved.</p>
<p>12. Final checking.</p>	

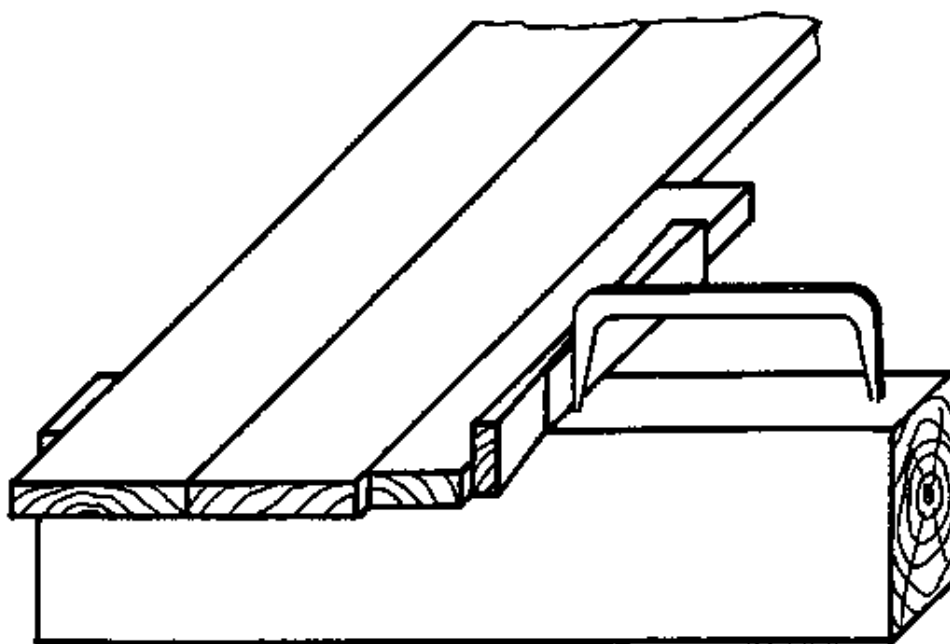
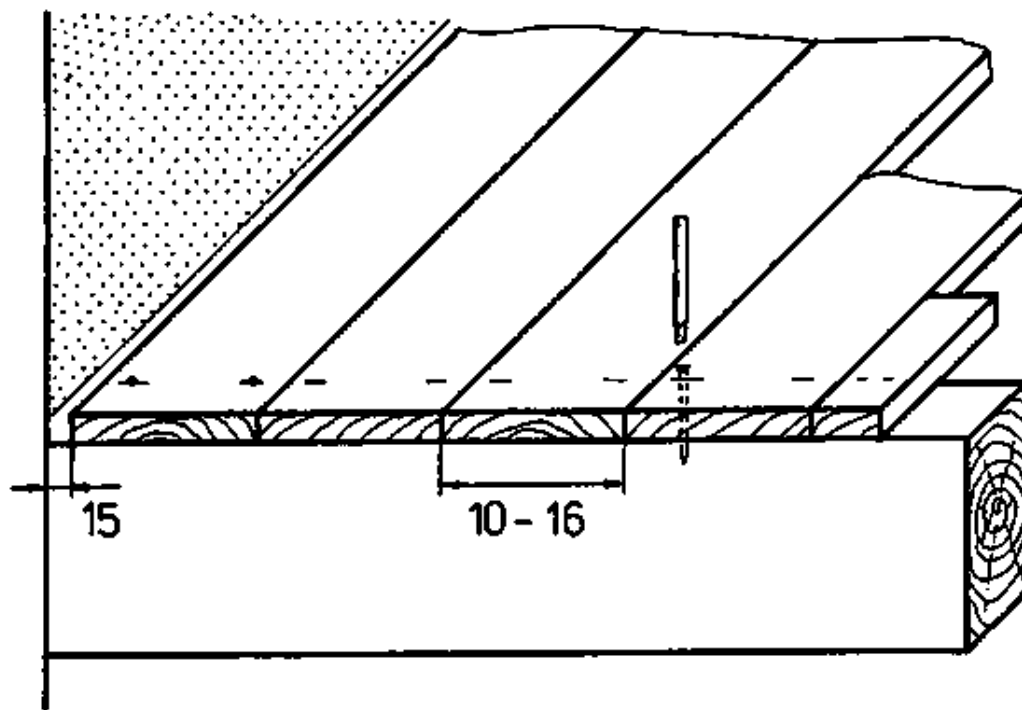

				6.2.
IBE	Mated surfaced deals			3606 ⁸

Instruction Example 6.3.: Laying of Matched Surfaced Deals

This instruction example is a practising exercise of laying matched surfaced deals.

Material

– Surfaced deals, matched

Thickness: 24 mm

Width: 120 mm

Length: 4000 mm

– Countersunk head nails

Thickness: 3.1 mm

Length: 70 mm

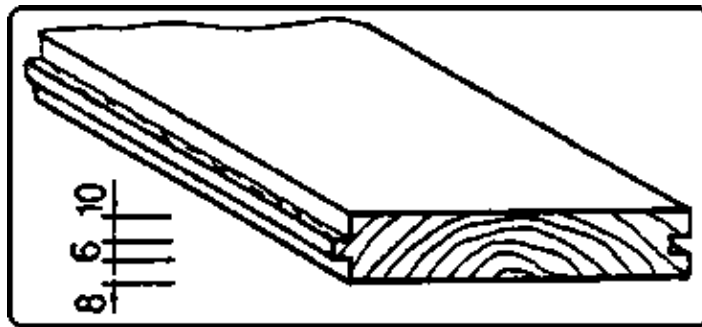

Tools

Hand saw with a tooth form suitable for cross cuts, hammer, axe, plane, chisel, nail punch

Measuring and testing means

Folding rule, flat or try square

Auxiliary accessories

Trestles approximately 600 mm high, deal cramps or steel cramps, wooden wedges and pieces of planks

Sequence of operations	Comments
1. Preparing the workshop place.	Check materials and tools for completeness, trestles for supporting the boards.
2. Measuring the room at several points.	Find out whether or not the length is the same over all distances measured.
3. Transmitting the determined length to the deals less 10–15 mm for an edge strip.	If the length of the deals is the same as that of the room, 10 to 15 mm for edge strips are deducted left and right.
4. Applying a square to the marking of the length, scribing and sawing the boards off accordingly with a hand saw.	If a number of deals of equal length are required, they may be put one upon the other and sawn at a time. A square is applied to the pile of boards and an

	additional vertical marking is made.
5. With open nailing, removing the tongue from the first deal. With covered nailing removing the rabbet from the first deal by sawing, chopping or planing.	Rabbet is not so easily damaged when the deals are driven together. With covered nailing the nails are driven obliquely into the tongue.
6. Laying the first deal 10 – 15 mm distant from the wall – edge strip – and nailing it with two nails on each beam.	With covered nailing fix the first deal with one nail driven in vertically and one nail driven obliquely into the tongue.
7. Putting five to six deals loosely in front of the fixed deal and driving them together one by one.	In doing so, use a piece of a board or plank to protect the deals against damages.
8. Driving a steel cramp in two to three beams –according to the length of the deals – at a distance of 100 – 150 mm and putting a piece of a plank and two wooden wedges between the deal and each cramp. Tightening the wooden wedges evenly and alternately with the hammer.	The wooden wedges are put one above the other only by their tips (20 – 30 mm).
9. Drawing with the pencil a thin nailing line on the deals – middle of the beams – nailing the deals from the front – cramps – to the rear.	The working steps of point 7 to point 9 are repeated.
10. With covered nailing, pressing the deals together one by one and fixing them on each beam with a nail which is driven in the tongue obliquely.	By the oblique nailing the deals are drawn together once again.
11. Putting the last deals in – open nailing – laying two to three deals starting from the wall and nailing them.	In doing so, the exact width of two, better four, deals must remain free between these deals and those already fixed. The clearance must be given short measure, so that the boards are closely together.
12. Inserting the deals from above in an inclined way, putting a board across them and pressing them down.	
13. With covered nailing driving wooden wedges between the last deal and the wall and pressing the deals tightly together.	Put a piece of a plank between the wooden wedges and the wall, in order to prevent the wall plaster from being damaged.
14. With open as well as with covered nailing let the nails project 1–2 mm, put the nail punch on each nail and drive it in completely, so that it is driven in 1 – 3 mm in the surface of the board.	The nail punch is used so that the surface and front edge of the tongue are not damaged. Then the holes over the nails are puttied up.
15. Cleaning the floor and removing with a plane superfluous wood that might be projecting at butts and joints.	Once again make sure that all nails are driven in correctly.
16. Final checking.	

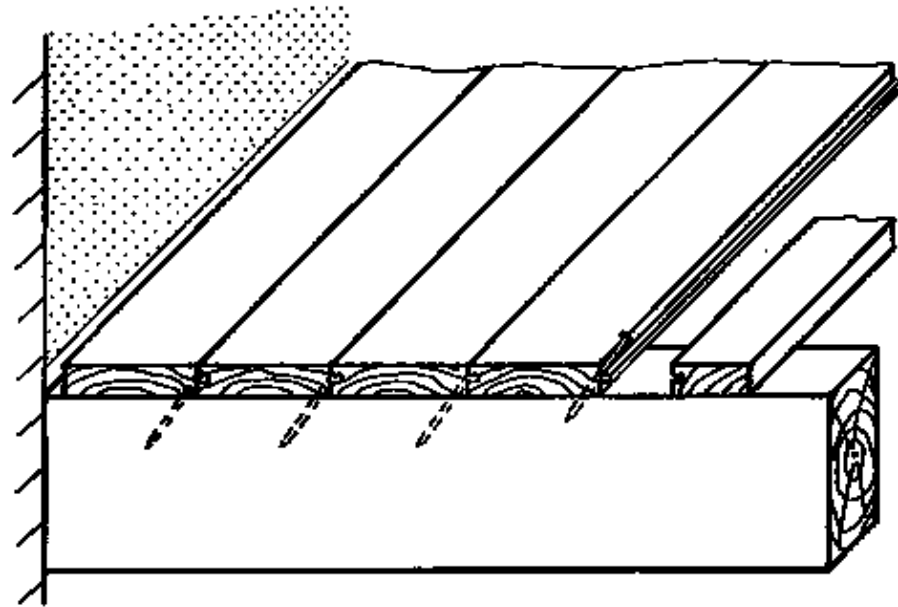
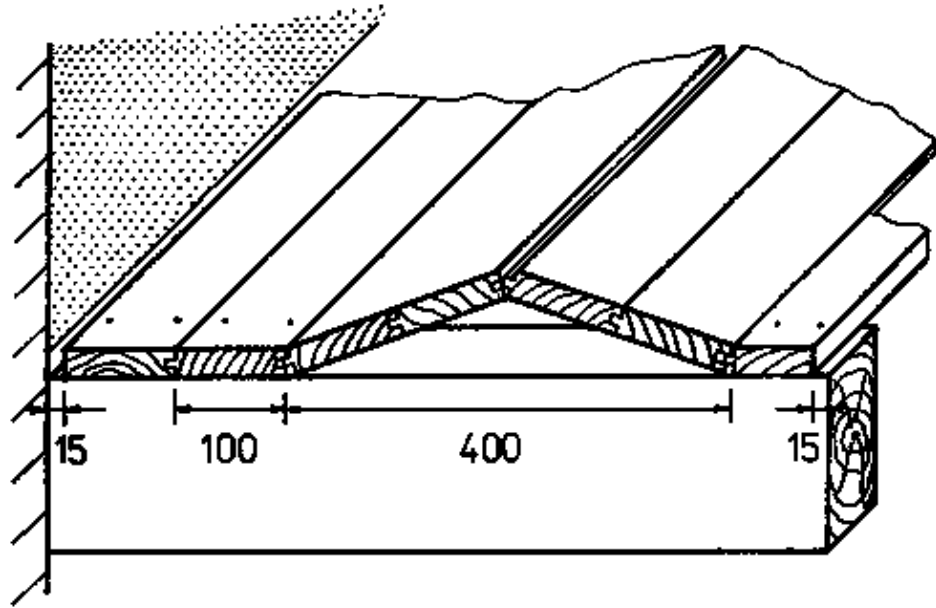

				6.3.
IBE	Matched surfaced deals			3606

Matched surfaced deals

Instruction Example 6.4.: Fixing of Skirting Boards

This instruction example shows how skirting boards up to 50 mm in height are nailed on the deals. The skirting boards may have different profiles according to the requirements.

Material

– Skirting boards

Height: 45 mm
Thickness: 24 mm
Length: 200–400 mm

– Countersunk head nails

Thickness: 3.1 mm
Length: 70 mm

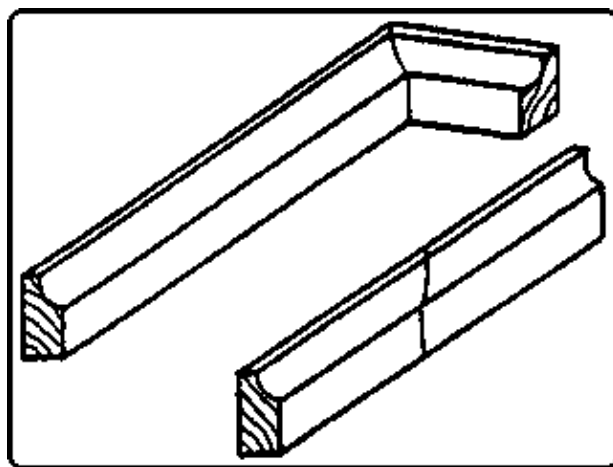

Tools

Hand saw, hammer, chisel, nail punch

Measuring and testing means

Folding rule, try square

Auxiliary accessories

Trestles approximately 600 mm high, mitre box

Required basic knowledge

Measuring, scribing, sawing, nailing, cutting

Sequence of operations	Comments
1. Preparing the workshop place.	
2. Starting work always in reentrant corners, putting the skirting board in the mitre box, cutting mitre inwards with hand saw.	Butt-join the skirting board in the middle of the wall, approximately.
3. Cutting the mitre inwards on the opposite end of the skirting board, too.	
4. Pressing the skirting board firmly to the wall, applying the nail obliquely and nailing the skirting board on the deals.	Skirting boards are fixed at distances of approximately 500–600 mm.

5. Cutting the mitre inwards in the next skirting board for the opposite corner.	
6. Putting the skirting board on the wall, exactly scribing the butt, then cutting mitre outwards and nailing the skirting board on the deals.	
7. With projecting corners cut the reentrant corner first, put the skirting board in place, then scribe the projecting corner and cut the mitre outwards.	If the corners are not accurately right-angled, rework the cut or change the mitre cut. The operations are repeated until the work is finished.
8. Possibly making ventilation slots in the skirting board.	Ventilation of the beam layer with rooms that do not have a cellar.
9. Final checking.	

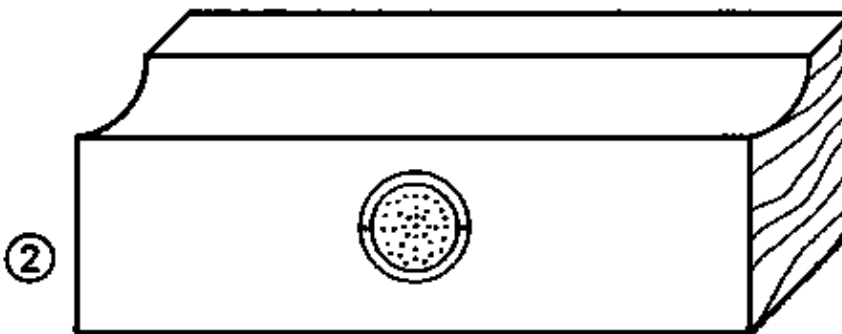
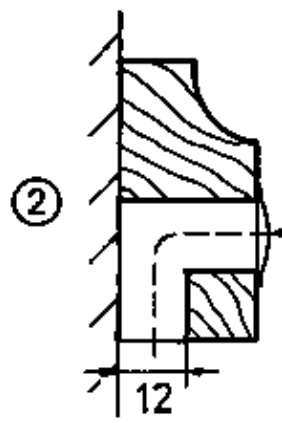
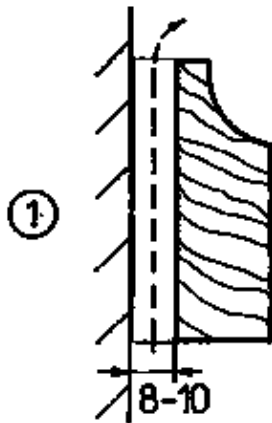
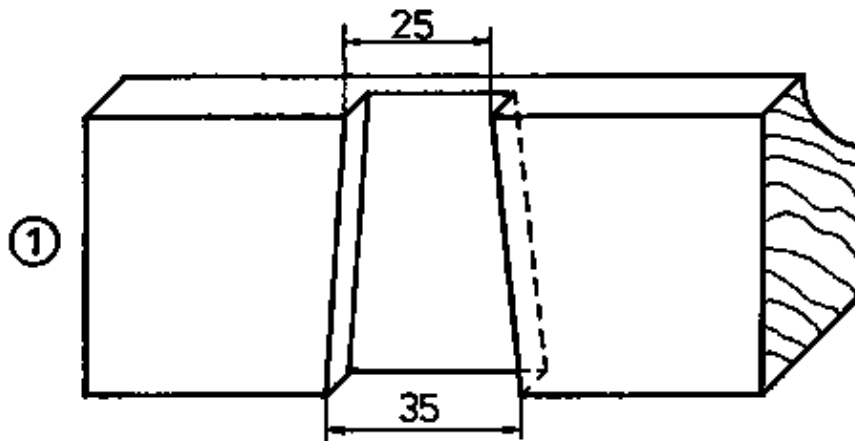

				6.4.
IBE	Skirting boards			3606

Skirting boards

**Making of Floors – Course: Timberwork techniques. Trainees'
handbook of lessons**

Table of Contents

<u>Making of Floors – Course: Timberwork techniques. Trainees' handbook of lessons</u>	1
1. <u>Task and Quality of Wooden Floors</u>	1
2. <u>Constructive Connections of Surfaced Boards</u>	1
3. <u>Nailing of Surfaced Boards</u>	3
4. <u>Tools and Equipment for Laying Surfaced Boards</u>	4
5. <u>Preparations for Laying Surfaced Boards</u>	4
6. <u>Laying of Surfaced Boards</u>	5
7. <u>Fixing the Skirting Boards</u>	7

Making of Floors – Course: Timberwork techniques. Trainees' handbook of lessons

Institut für berufliche Entwicklung e.V.
Berlin

Original title:
Arbeitsmaterial für den Lernenden
"Herstellen von Fußböden"

Author: Horst Hofmann

First Edition © IBE

Institut für berufliche Entwicklung e.V.
Parkstraße 21/23
13187 Berlin

Order No.: 93–35–3606/2

1. Task and Quality of Wooden Floors

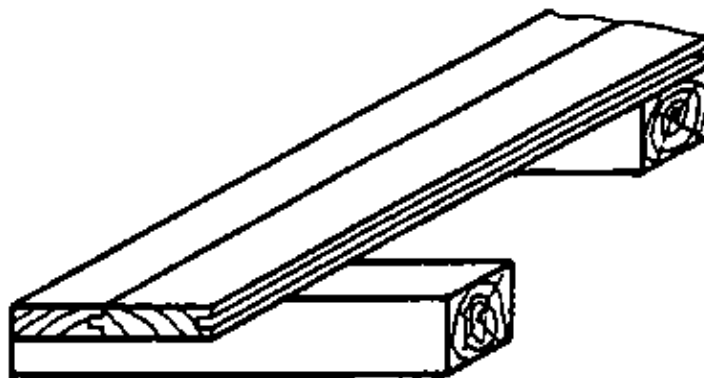

Figure 1

Wooden floors are made from surfaced boards. These shall bridge the spaces between the floor beams or fillets. The surfaced boards form a self-contained horizontal surface which can be well walked on, receive loads and transmit them to the subconstruction.

Surfaced boards shall be of equal thickness, as far as possible of equal parallel width, free from knots and surfaced on one side. They consist of soft wood or hardwood suited for that purpose. They shall be 120 to 160 mm broad and – in surfaced condition – 20 to 24 mm thick. Wooden floors have little dead weight, are relatively elastic and foot-warm. On the other hand, they may be subject to deformation, because wood contracts and expands due to reception of moisture or drying. Wooden floors are easily inflammable, they rot under the influence of moisture and they are susceptible to destructive insects.

What disadvantages do wood floors have?

2. Constructive Connections of Surfaced Boards

– Joint boarding

The boards are connected by straight or inclined joints.

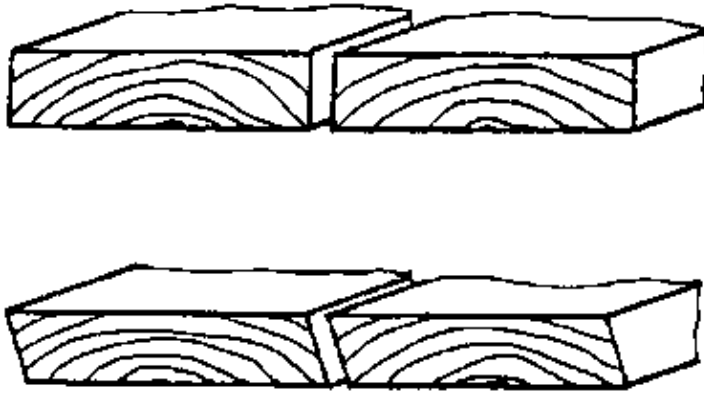

Figure 2

Nailing is open (visible).
Joint boards are used in buildings of less importance.

– Rebated boarding
The boards mate by rebates.

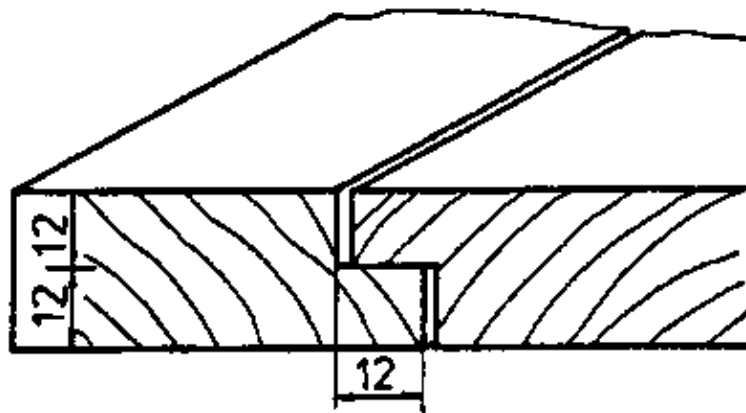

Figure 3

Nailing is open.
Rebated boards are used in buildings of less importance, too.

– Tongued boarding
The boards get grooves on both longitudinal sides in which tongues from wood – hardwood is recommended – or flat irons are shoved.

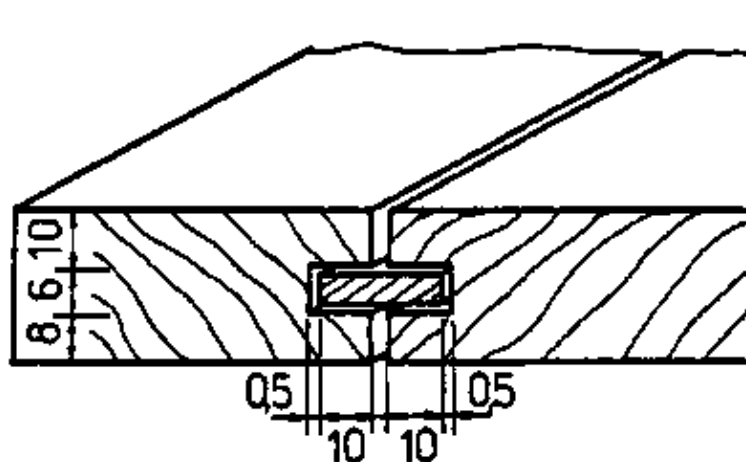
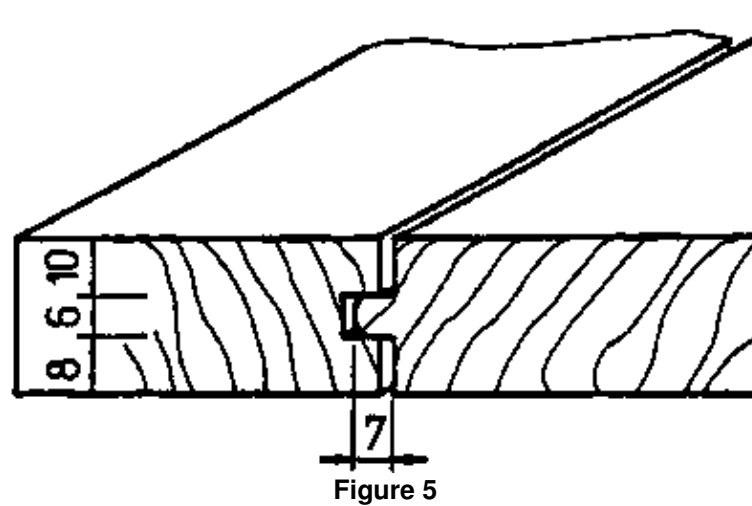

Figure 4

Open nailing is preferred. Covered nailing is possible only in some cases. Tongued boarding can be used in buildings of less importance and in flats.

- Matched boarding
The boards are connected by tongue and groove joints.



This technique provides a solid and dense floor serving many purposes. Open and covered nailing is possible.

Which kind of boarding is the most recommendable one?

3. Nailing of Surfaced Boards

For nailing surfaced boards countersunk head nails should be used. These nails are easier to flush with the surface of the wood. The length of the nails should amount to the triple thickness of the boards, approximately.

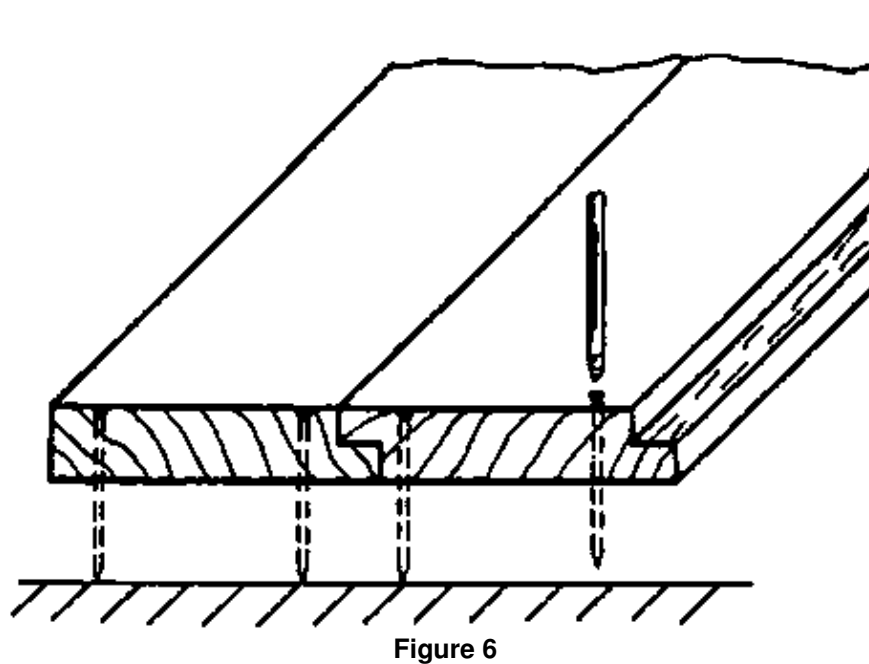

With open nailing – visible – each board is fixed by two nails on each beam.

For covered nailing only matched boarding is suited.

Here, one nail is driven obliquely in the groove and tongue.

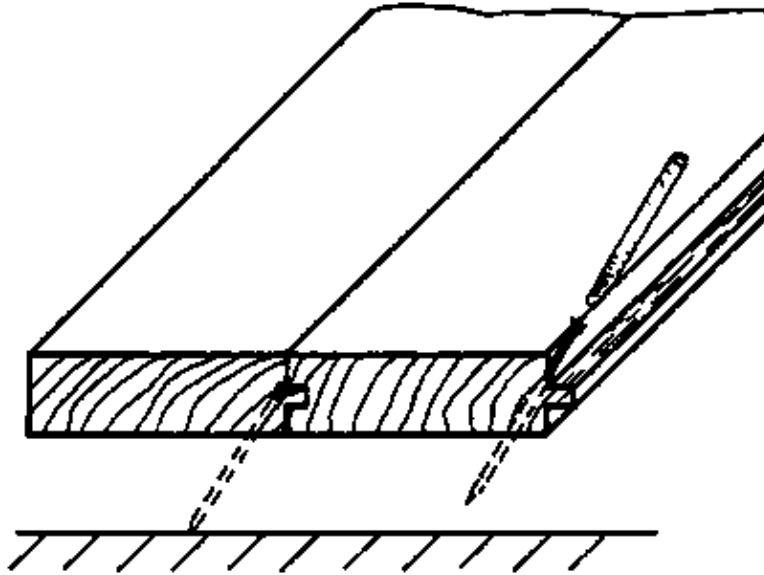

Figure 7

With open, as well as with covered nailing the nails are not completely driven in. Otherwise there is the risk that the surface or, with covered nailing, the groove and tongue and the front edge of the boarding are damaged. The nails are allowed to project 1 to 2 mm; then they are driven in with the help of the nail punch. The hollows in the surface of the boards left by this technique can be puttied up.

When can the technique of covered nailing be used?

4. Tools and Equipment for Laying Surfaced Boards

The following working means are employed:

- Tools
Hand saw, hammer, nail tongs, plane, axe, nail punch.
- Measuring and testing means
Folding rule, iron square, water-level, level board (a plane parallel board).
- Auxiliary accessories
Trestles for supporting the boards, steel clamps for the boards, wedges and pieces of planks.

5. Preparations for Laying Surfaced Boards

The beam systems must be prepared in such way that their surface is plane and horizontal and completely levelled before the boards are laid.

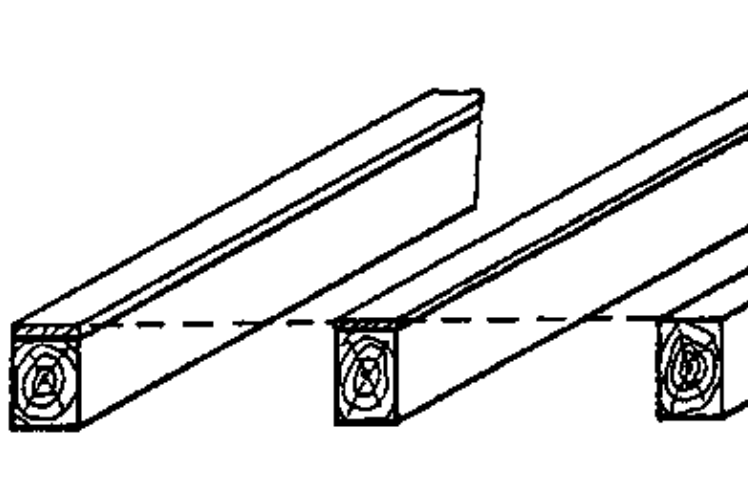

Figure 8

If supporting laths are placed on solid floors, strips of bituminous felt are laid under the laths for protection against moisture.

The supporting laths, too, are laid horizontally. Here, adjustment is achieved by putting short pieces of planks, bituminous felt or other suitable material under them. These backings are closely spaced and across the supporting laths in order to avoid that the laths deflect. Before being laid the supporting laths must be impregnated with a timber preservative for protection against rot.

What has to be considered, if boarding shall be laid on an already existing old layer of beams?

6. Laying of Surfaced Boards

After the preparations are completed and material, tools, measuring and testing means are ready, the following operations have to be started:

- Measuring of the space across the beams.

The determined length, less 20 – 30 mm, if the boards are not butt-jointed, is marked on the boards.

A square is applied to the length marking, the marking is scribed reactangularly and the board is sawn off.

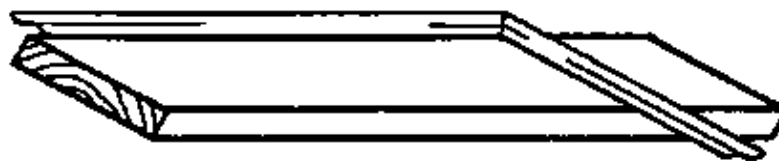

Figure 9

Attention!

Between surfaced boards and abutting fixed parts of a building such as walls or pillars a strip of 10 –15 mm in width has to be left open, which, after the boards are laid, is covered with skirting boards.

Due to the skirting board the wood can better contract and expand. If the boarding absorbs moisture and rises it is not squeezed by the beams.

If matched boards are laid, the tongue is removed from the first board or – with covered nailing – the groove or – in case of rebated boards – the rabbet.

It can be sawn off, chopped off or jacked down. After this, the first board is laid 10–15 mm off the wall and nailed.

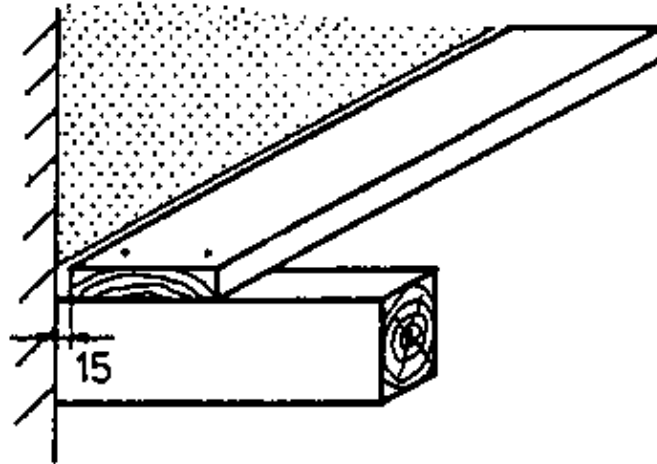

Figure 10

– In front of the first fixed board, another five to six boards are laid loosely and one by one driven together by slight hammer blows. In doing so, a piece of a plank or, which is even better, a piece of a board is placed between the hammer and the respective board to prevent it from being damaged.

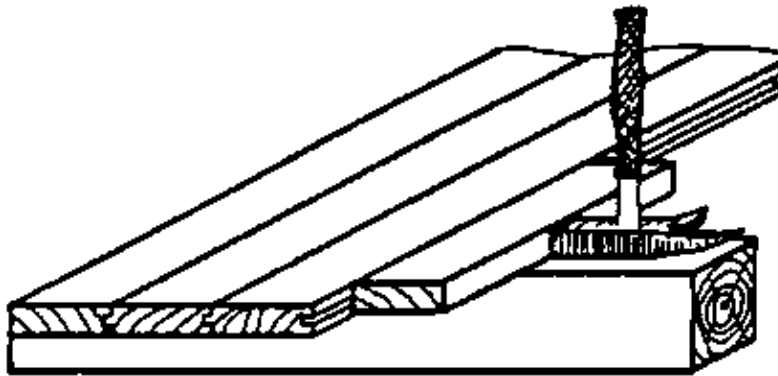

Figure 11

– Next to these deals, deal cramps are fixed on the beams which press the deals closely together. If no such cramps are available, steel cramps – according to the length of the deals – are driven into the beams. A piece of a plank and two wooden wedges are put between the deals and each cramp. Now the wedges are equally fastened with the hammer and thus the deals pressed together closely.

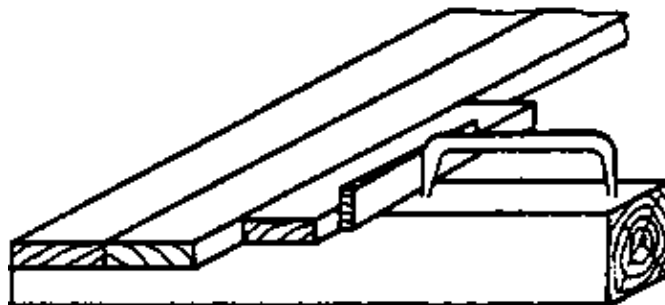

Figure 12

With a pencil a thin nailing line is scribed, and the deals are nailed along this line.

Attention!

With covered nailing, each deal must be driven to the neighbouring one and be nailed immediately. If the deals are butt-jointed, the joint has to be staggered at an interval of 1000

mm, approximately. This helps to distribute loads and vibrations over several beams.

When laying planed boards, the beams have to be covered with planks, so that safe working is possible.

– Putting the last deals in.

With open nailing two to three deals are laid starting from the wall and nailed.

Between these deals and those already laid before, the exact width of two or better four deals must remain free.

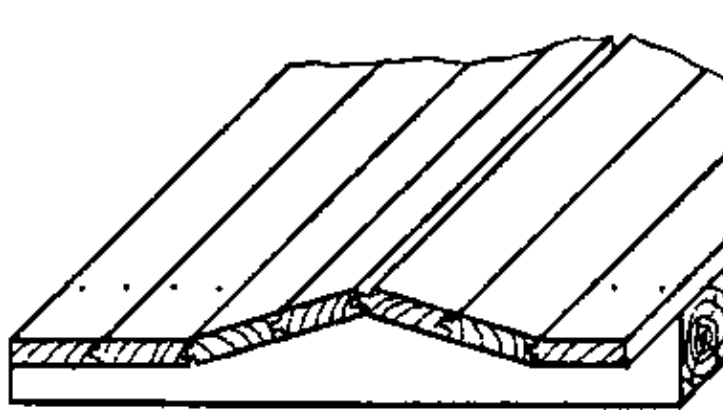

Figure 13

In this interspace the deals to be completed are put in an inclined position from above, so that they show upwards at an obtuse angle. Then, a plank is placed across these deals and one steps on the plank forcing the deals into the interspace by one's weight. With covered nailing, wooden wedges are driven between the last board and the wall until they are close together.

– Levelling of the surface

After all nails are driven in and the deals are cleaned, wood which may be projecting at butt-joints or other places is smoothed with a plane. This way an even, plane surface is reached.

How are deals pressed tightly together?

7. Fixing the Skirting Boards

It is the task of the skirting boards to cover the strip between planed boards and walls. Furthermore, they shall protect the plaster of the walls, the wall paper or painting against damages that might be caused when the floor is cleaned.

Skirting boards are manufactured 40 to 80 mm high and 20 to 30 mm thick and with different profiles according to the requirements.

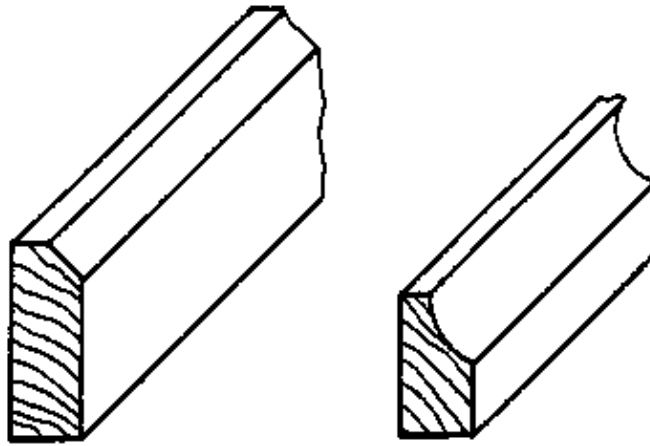

Figure 14

When the skirting boards are fixed, they are butt-joined with a mitre cut (normally 45°) in the reentrant and projecting corners as well as in longitudinal direction.

For these cuts a mitre box is used, which one can make by oneself.

Skirting boards up to 50 mm in height can be nailed on the deals or fixed on the wall with steel nails.

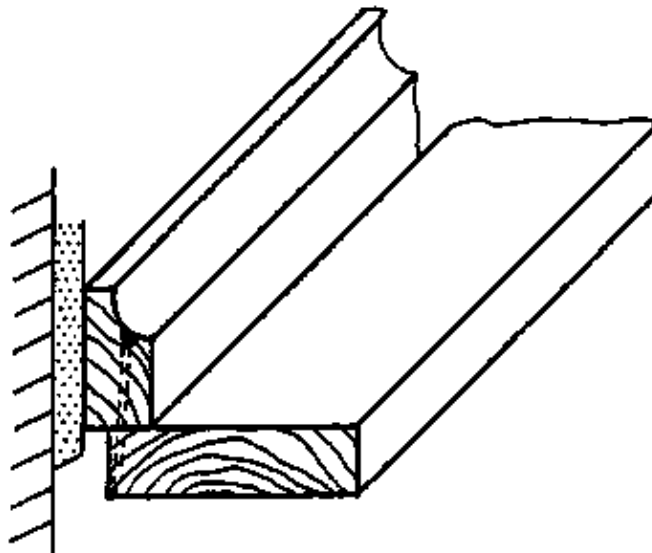

Figure 15

Skirting boards of more than 50 mm in height are fixed on the wall with steel nails or are screwed to previously set plugs or expansion dowels.

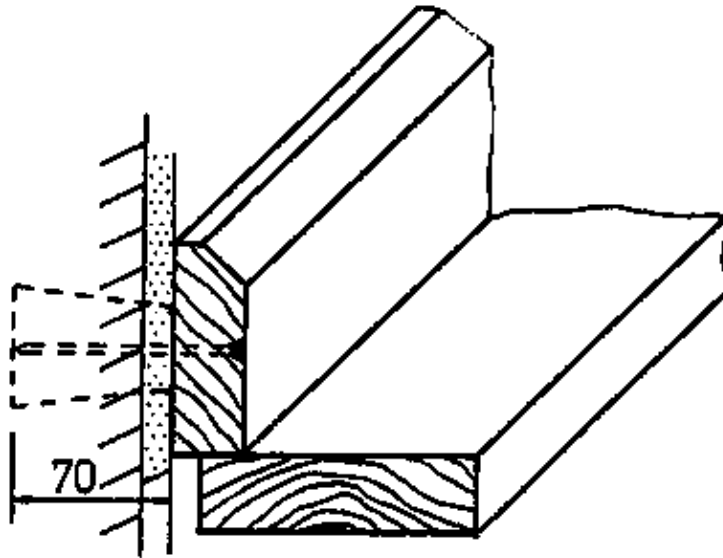

Figure 16

Attention!

The cavities between the beams and/or supporting laths must be ventilated through holes in the cover strips. In rooms without basement good ventilation is absolutely necessary in order to avoid rot at all wooden parts.

How is the skirting board joined in an angular corner?

What must be provided for if there is no cellar under the floor?

What is the last operation after all deals are nailed?

**Formwork Making – Course: Timberwork techniques. Instruction
examples for practical vocational training**

Table of Contents

<u>Formwork Making – Course: Timberwork techniques. Instruction examples for practical vocational training</u>	1
<u>Preliminary Remarks</u>	1
<u>Instruction Example 1.1. Prefabrication of Formwork Panels</u>	1
<u>Instruction Example 1.2. Ceiling Formwork Making</u>	3
<u>Instruction Example 1.3. Strip Foundation Formwork Making</u>	6
<u>Instruction Example 1.4. Beam Formwork Making</u>	8
<u>Instruction Example 1.5. Column Formwork Making</u>	11

Formwork Making – Course: Timberwork techniques. Instruction examples for practical vocational training

**Institut für berufliche Entwicklung e. V.
Berlin**

Original title:

Lehrbeispiele für die berufspraktische Ausbildung
"Herstellen von Schalungen"

Author: Peter Wehrmann

First edition © IBE

Institut für berufliche Entwicklung e.V.
Parkstraße 23
13187 Berlin

Order No.: 93–33–3601/2

Preliminary Remarks

The present booklet contains 5 selected instruction examples to practise making of different types of form-work.

The first example serves for practising the prefabrication of formwork panels.

Prefabricated formwork panels are indispensable for beam and column formworks. Prefabricated formwork panels, however, are also recommended for series production of foundation and ceiling formworks.

In that case the construction of the panels differs from that of panels for beam and column formworks but the technology of prefabrication is the same.

The construction of a multi-use formwork panel for beam and column formwork is explained and shown in the Trainees' Handbook of Lessons.

Thus example 1.1. represents direct or possible preparations for the other four examples and, therefore, there is a close technological connexion between them. The examples 1.2. to 1.5. explain how to produce the four most common types of formwork.

The required materials, tools and auxiliary accessories are specified for each example.

Moreover, the necessary previous knowledge is stated which is the basis for independent practising by the trainee.

The order of working steps of the relevant sequence of operations for the individual examples has been established by experience. If it is strictly followed, no faults would normally occur.

The examples selected can be modified to suit the relevant site conditions. Specific modifications ordered, however, may require changes to the sequence of operations.

Instruction Example 1.1. Prefabrication of Formwork Panels

This example serves for practising the prefabrication of formwork panels for beam and column formworks, in particular the prefabrication of a bottom panel for beam formwork.

Material

Formwork boards – 25 mm thick
nails – 40 mm and 70 mm long

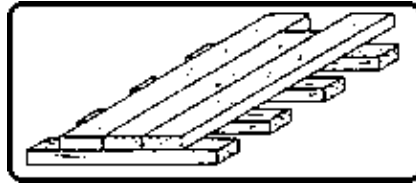

Hand tools and machines

Circular saw, hand saw, hammer, wrecking bar with claw

Measuring and testing means

Folding rule, try square, measuring rods

Auxiliary accessories

Pencil, paper

Necessary previous knowledge

Handling of length measuring tools, scribing, working with the circular saw and manual sawing

Explanations to the working drawing

1 formwork bottom, 2 cover strap projection, 3 sheeting thickness, 4 cover strap thickness 25 mm, 5 thrust-board width 100 mm

Sequence of operations

1. Prepare the work.
2. Enter all sizes required into the working drawing.
3. Cut up the boards.
4. Cut the stiffening cover straps to length.
5. Put the cover straps on the arranged boards according to the size distribution made.
6. Nail the cover straps on the board-panel.
7. Nail the cover straps on the boards from the opposite side.
8. Clinch the nail tips.

Comments

- Make available the tools and materials. A work table is to be manufactured (See Fig. 10 in the Trainees' Handbook).
- Derive the sizes from the dimensions of the beam for which the formwork is to be made. Prepare the size distribution of the cover straps in particular.
- The board width should not exceeded 140 mm. Do not place the rough edge of the board to the inside of the formwork!
- Cover straps to have a width of approx. 55 mm with 25 mm projection for corner joints!
- Use measuring rod, if necessary!
- It is provisional nailing with short nails (40 mm). Use as many nails as necessary to make the panel stable in itself.
- Turn over the provisionally nailed board-panel and nail it with 70 mm long nails. Two nails per board are to be diagonally arranged at the cover strap joint!
- Turn over the panel again and clinch the penetrated nail tips!

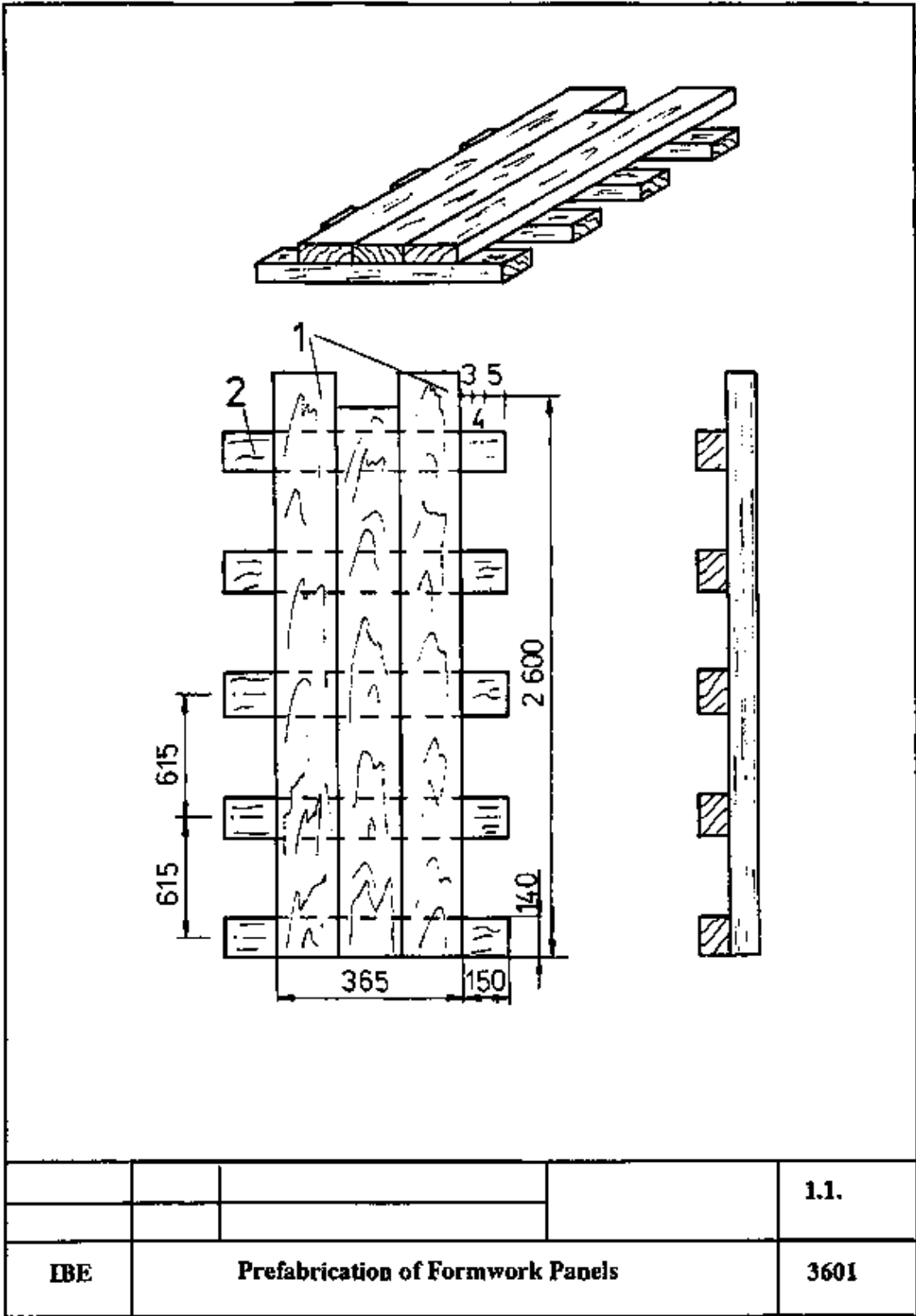

Prefabrication of Formwork Panels

Instruction Example 1.2. Ceiling Formwork Making

This example serves to practise making of a ceiling formwork in a room of given dimensions.

Material

Formwork boards 25 mm thick
 squared timbers 120 mm x 100 mm
 round timbers of 150 mm diameter
 various wooden wedges
 nails of different sizes

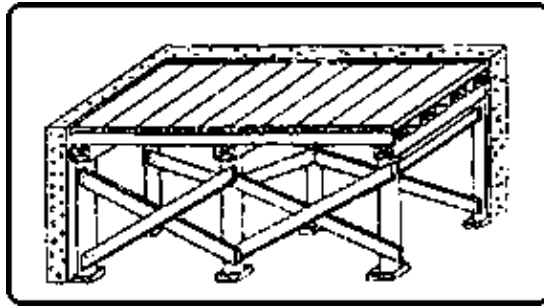

Hand tools and machines

Circular saw, hand saw, hammer, wrecking bar with claw, nail pincers

Measuring and testing means

Folding rule, try square, water level, measuring rod

Auxiliary accessories

Paper, pencil

Necessary previous knowledge

Manual sawing, working with the circular saw, measuring , scribing, nailing, sketching

Explanations to the working drawing

1 walling, 2 trestle timber, 3 formwork bearer, 4 sheeting boards, 5 diagonal (cross) bracing

Sequence of operations

Comments

- | | |
|---|---|
| 1. Study the formwork project and/or prepare a formwork sketch. | Dimensions in the instruction example are guidelines only! |
| 2. Make available the required tools and materials. | Use sharpened sawing tools only! |
| 3. Determine the column height and cut up the column. | Six columns are to be produced; the height depends on the height of the room (see Trainees' Handbook)! Cleats for fixing are to be provided at the sides of the columns! |
| 4. Cut the trestle timbers to length. | For an assumed narrow side of the room of 3.5 m three trestle timbers are to be produced! |
| 5. Fix the trestle timbers, cut up and nail diagonal bracing and erect the trestle. | Fix the trestle timbers through the cleats to the columns. Lean the right and left trestles and one side of the centre trestle against the wall! The trestles are to be put to the floor for nailing. |
| 6. Secure the trestles provisionally. | Erect the trestles and drive wedges between the wall and end face of the trestle timbers. 3 persons are required for this work! |
| 7. Level the trestles. | Use water level and levelling board for levelling. Adjust the height of the columns by means of packing wedges. Columns must be exactly perpendicular. |

8. Fix the formwork bearers on the trestles.

Cut formwork bearers to length and put them on the trestles at certain intervals (60 to 70 cm). Ensure parallelism! Use nail pins for fixing.

9. Nail on the sheeting boards.

Cut sheeting boards to length and nail them onto formwork bearers. In view of later stripping, do not use nails which are longer than 50 mm!

10. Check the formwork for accuracy to size and for strength.

Make corrections in case of deviations. For bigger rooms place more columns under the trestles.

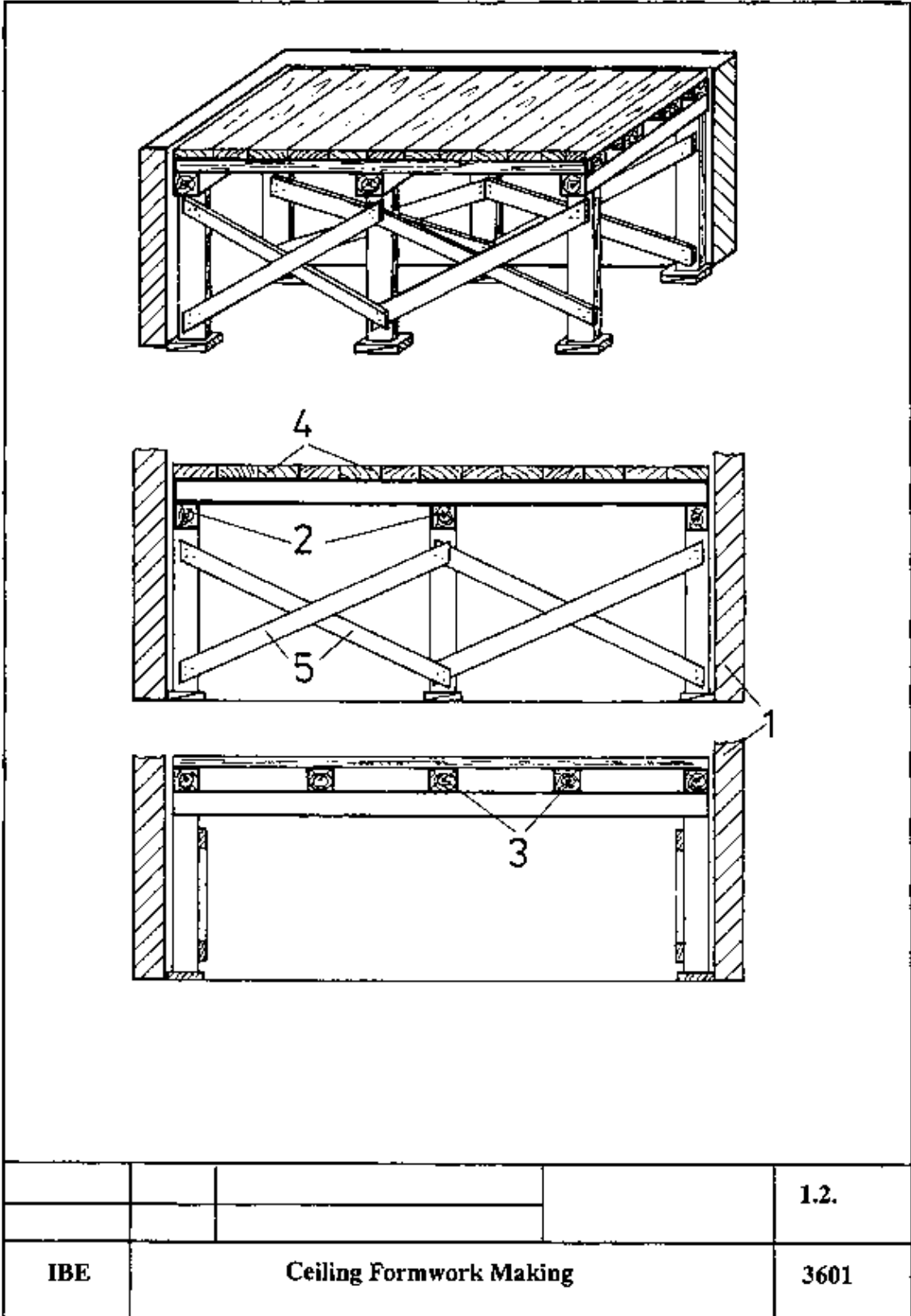

Ceiling Formwork Making

Instruction Example 1.3. Strip Foundation Formwork Making

This example serves to practise making of a strip foundation formwork to given dimensions of a drawing (without lateral border).

Material

Formwork boards
square timbers
nails of different sizes
tie wire
steel nails

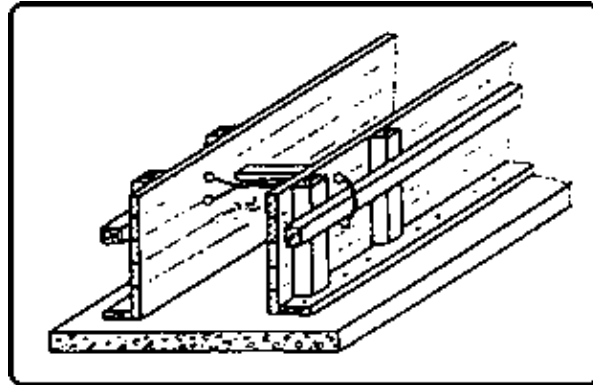

Hand tools and machines

Circular saw, hand saw, hammer, wrecking bar with claw, nail pincers, bit, bit brace

Measuring and testing means

Folding rule, try square, water level, measuring rods

Auxiliary accessories

Paper, pencil, line

Necessary previous knowledge

Handling of length measuring tools, scribing, manual sawing and working with the circular saw

Explanations to the working drawing

1 stull, 2 formwork sheeting, 3 post, 4 waler, 5 width of foundation, 6 steel rod for tying of the tie wire, 7 tie wire

Sequence of operations

1. Study the formwork project.
2. Stretch the alignment lines.
3. Nail a formwork bottom board onto the foundation.

Comments

Under the strip foundation to be erected there must be a horizontal layer of concrete (approx. 100 mm)!

The upper edges of the foundation determine the points of alignment of the lines. Use line supports or other measuring point aids!

Nail on the formwork bottom board with steel nails exactly in alignment.

- | | |
|--|---|
| <p>4. Erect the vertical post timbers</p> <ul style="list-style-type: none"> - Distances between the post timbers: 600 mm - Length of the post timbers depending on the foundation height. | <p>After erection of the post timbers fix them with nail pins. On top the post timbers are to be stabilize by stulls to be nailed on!</p> |
| <p>5. Fixing of the sheeting boards to the post timbers by nailing.</p> | <p>Start nailing from the bottom!</p> |
| <p>6. Fixing of horizontal walers (both sides) to the post timbers by nail pins.</p> | <p>The distance of the walers from the formwork bottom boards depends on the height of the foundation and is approximately 1000 mm.</p> |
| <p>7. Place steel reinforcement, if provided for.</p> | |
| <p>8. Nail stulls on top of the side walls near the places of tying (by tie wire).</p> | <p>The stulls must only slightly project over the formwork sheeting!</p> |
| <p>9. Tie the formwork from waler to waler at distances of 600 mm by means of tie wire.</p> | <p>Wire to be guided through previously bored holes in the formwork sheeting (see working drawing).</p> |
| <p>10. Check the whole formwork again for alignment and accuracy to size and stabilize it laterally by diagonal bracing to the subsoil.</p> | <p>Make corrections in case of dimensional deviations!</p> |

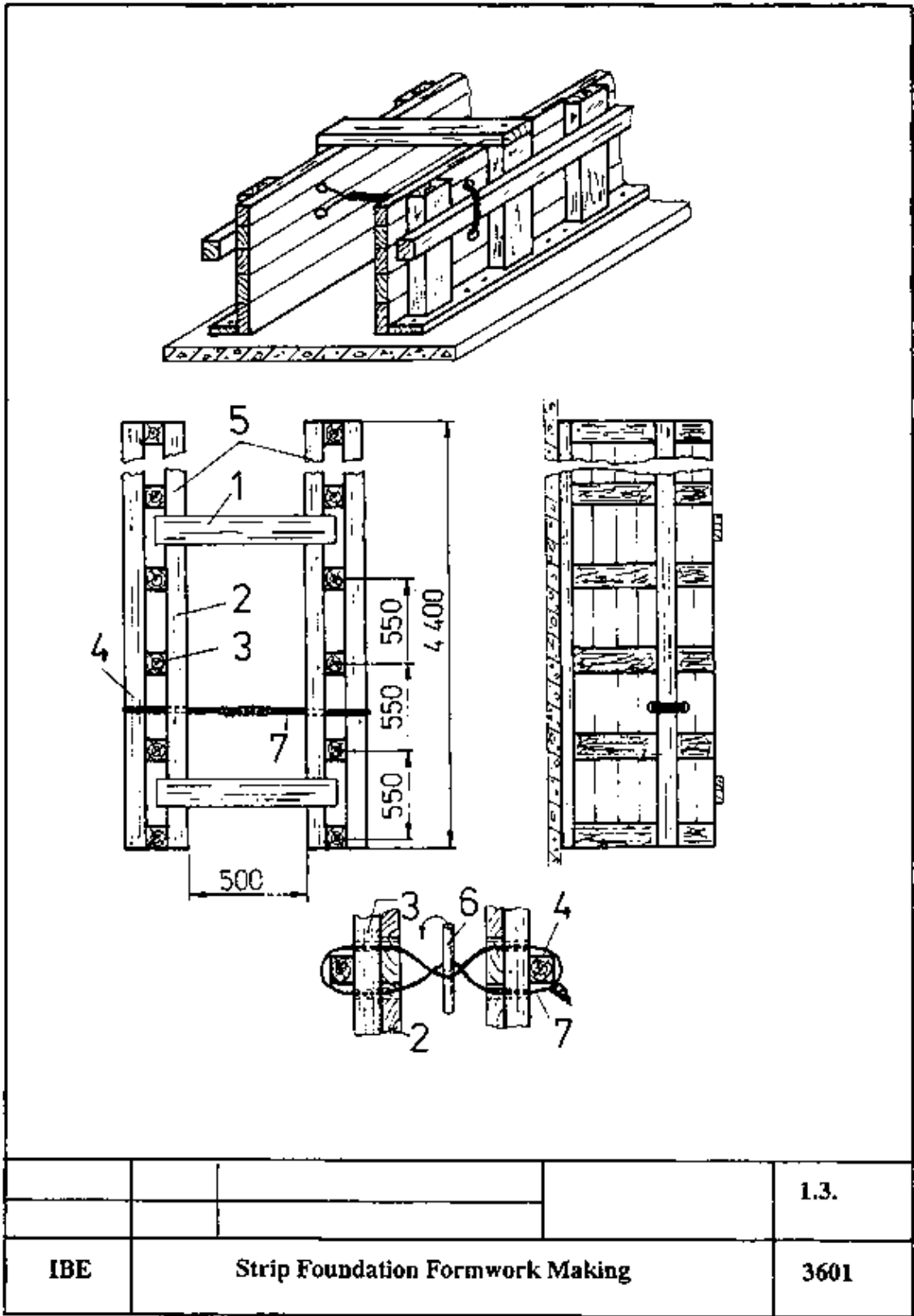

Strip Foundation Formwork Making

Instruction Example 1.4. Beam Formwork Making

This example serves to practise making of a beam formwork for a brickwork wall coping to given sizes.

Material

Formwork boards
 squared timbers
 nails of different sizes
 tie wire

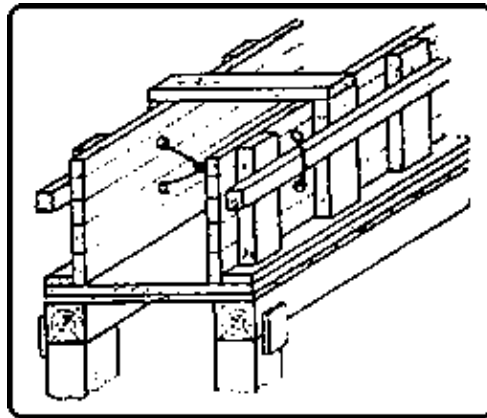

Hand tools and machines

Circular saw, hand saw, hammer, wrecking bar with claw, nail pincers, bit, bit brace

Measuring and testing means

Folding rule, try square, water level, measuring rods

Auxiliary accessories

Paper, pencil

Necessary previous knowledge

See ceiling formwork

Explanations to the working drawing

1 brickwork, 2 brickwork support, 3 stull, 4 formwork side panel, 5 cover straps, 6 waler, 7 formwork bottom panel

Sequence of operations

1. Study the formwork project. Prepare the work.
2. Make two trestles (columns connected with trestle timber through cleats) for the longitudinal front of the wall.
3. Erect the trestles and secure them laterally by wedges.
4. Nail on two board-connectors at the left and right of the beam wall support.
5. Fix the diagonal bracings to the columns.
6. Make the formwork bottom (See instruction example 1.1.):
7. Put the prefabricated side panels on the cover strap projection at the left and right sides and

Comments

- Make available the tools and materials.
- Dimension the height of the columns so as to allow for two packing wedges, the formwork sheeting (sheeting boards)!
- Trestles to stand exactly at the outside wall lines!
- The 200 mm distance to the wall must correspond with the cover strap dimensions. Upper edge of formwork sheeting is equal to lower edge of beam!
- Nail bracings longitudinally and transversely to the wall!
- Do not cut the cover straps flush but make allowance at both sides at least for formwork sheeting thickness, cover strap thickness and thrust-board width!
- According to the brickwork support openings of the beam, the length of the side panels is to be dimensioned

- connect them with stulls on the upper edges. so as to permit that the supports are enclosed by the formwork at both sides!
8. Nail on a thrust-board at the lateral foot of the formwork panels. Nail on from both sides!
9. Fix walers at the sides of formwork panels (upper end). Fix walers laterally with nail pins!
10. Tie the formwork with tie wire at the walers. The walers must also cover the brickwork support openings. The tie-wire tying is to be provided immediately near the stulls!
11. Check the formwork again for alignment and accuracy to size. Make corrections, if necessary.

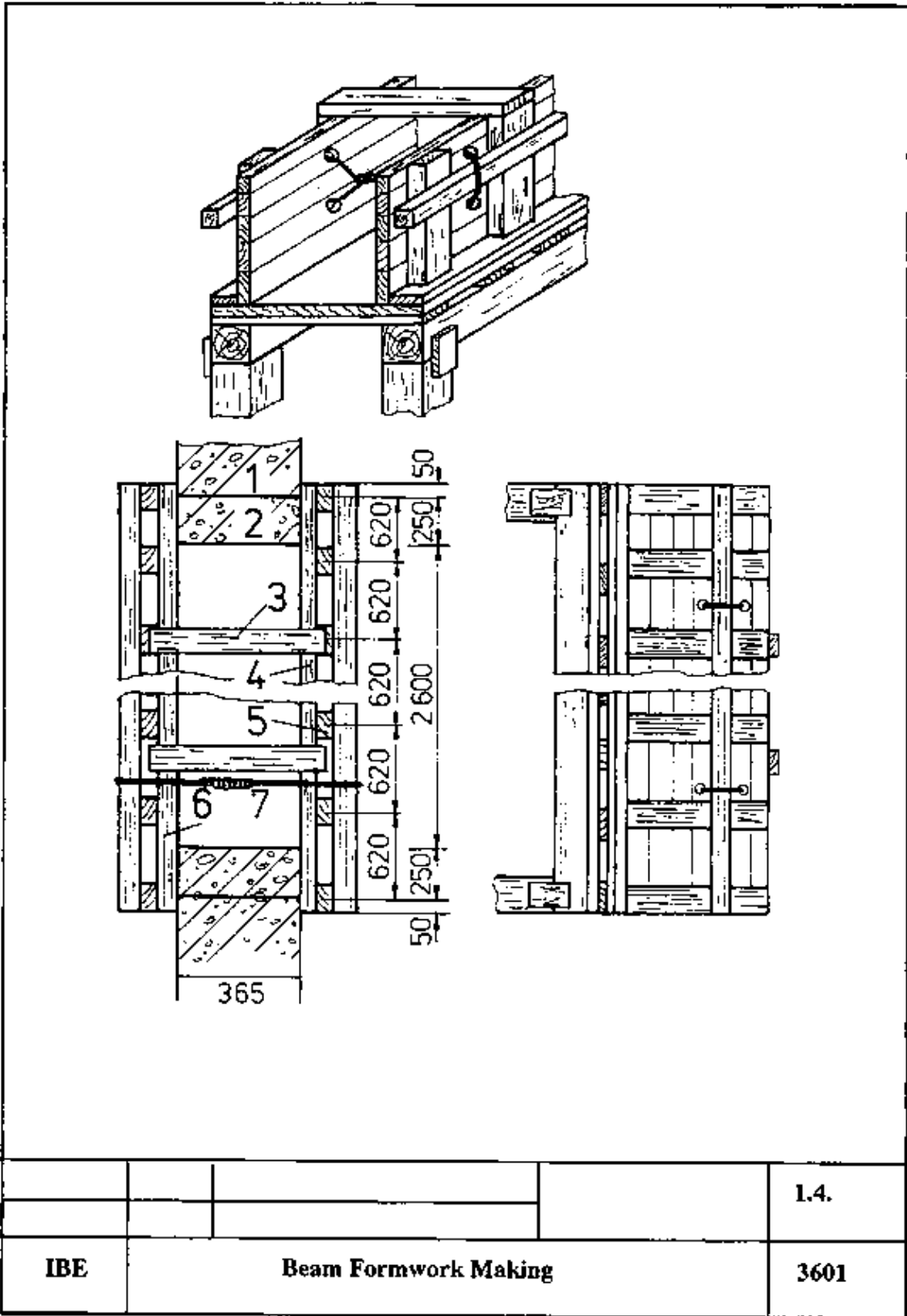

Beam Formwork Making

Instruction Example 1.5. Column Formwork Making

This example serves to practise making of a column formwork to given sizes.

Material

Formwork boards
squared timbers
nails of different sizes

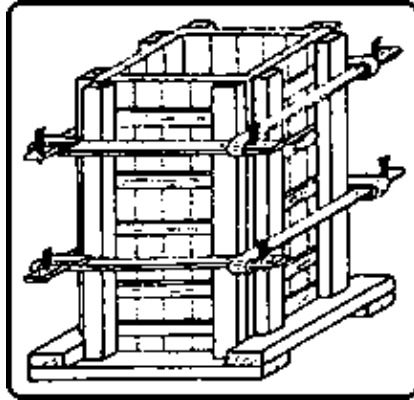

Hand tools and machines

Circular saw, hand saw, hammer wrecking bar with claw, nail pincers, column clamps of steel with steel wedges

Measuring and testing means

Folding rule, try square, water level, plump

Auxiliary accessories

Paper, pencil

Necessary previous knowledge

See ceiling form work

Explanations to the working drawing

1 arch timber, 2 formwork sheeting, 3 steel clamps, 4 steel wedge, 5 cover straps of formwork sheeting panel, 6 foot rim, 7 nailing, 8 steel nails

Sequence of operations Comments

- | | |
|--|--|
| 1. Study the formwork project. | Make available the tools and materials. |
| 2. Scribe the size of the column on the concrete bottom. | If steel reinforcements project from the concrete bottom, they are to be connected with the column reinforcement! |
| 3. Nail the column rim on the concrete. | The inside dimensions of the column rim must allow for 25 mm sheeting thickness per side. The column rim is to be prefabricated from boards! |
| 4. Erect one column comer. | Alternately insert two prefabricated panels in the column rim to form a comer and nail them together. If necessary, support them diagonally by boards! |
| 5. Place the reinforcing steel. | |
| 6. Erect the second column comer. | Insert the remaining two panels in the column rim and nail them alternately! One panel must have a cleaning hole at the foot! |
| 7. Erect the arch timbers. | Erect and fix with nails two arch timbers (100 mm x 100 mm) at both sides of each corner! Make sure that the column formwork is perpendicular! |

8. Tie the column formwork.

Wrap column clamps of flat steel around the arch timbers and tighten them with steel wedges. The vertical distance between the column clamps should be approximately 700 mm. If no steel clamps are available, use wooden rims!

9. Check the alignment and accuracy to size.

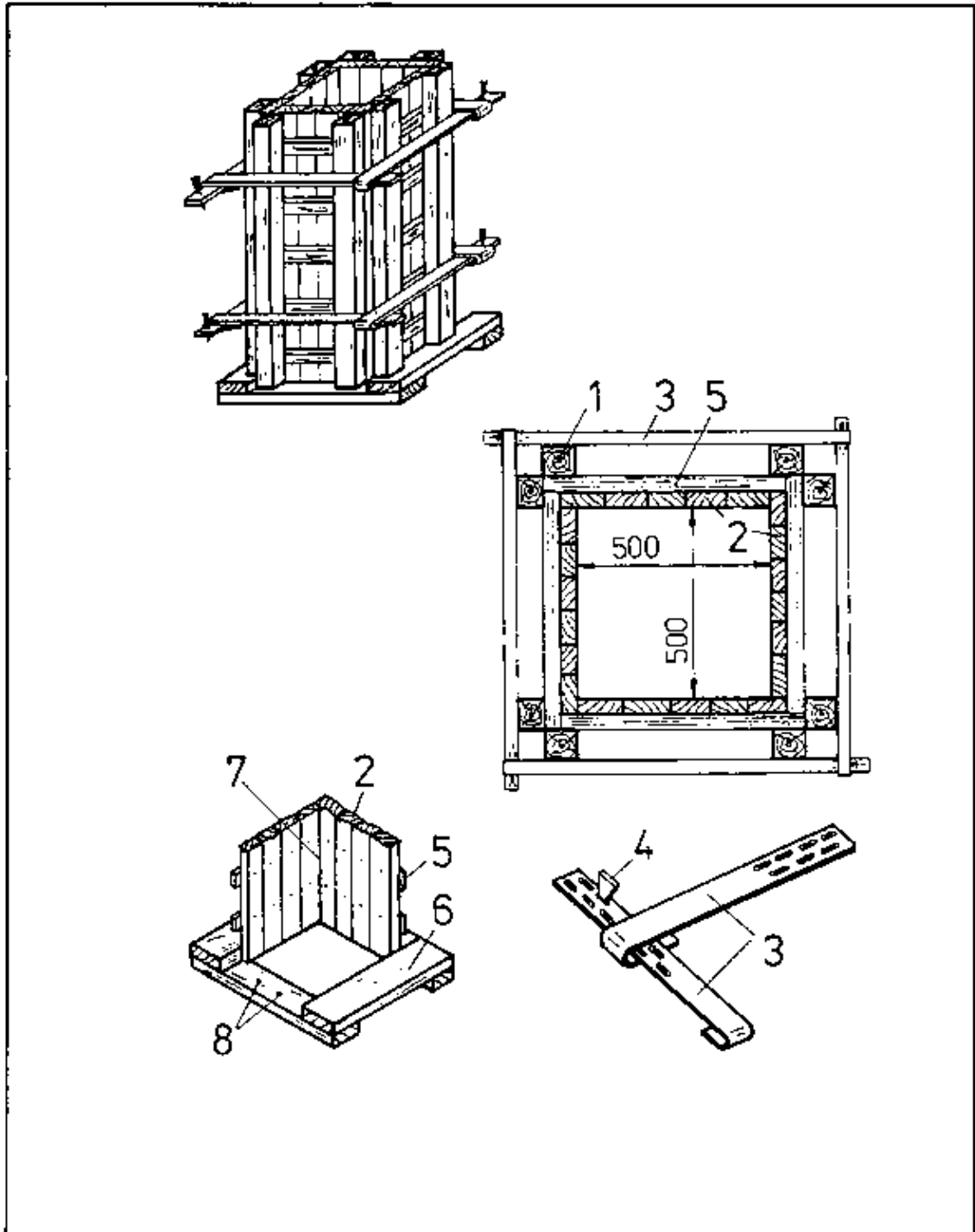

			1.5.
IBE	Column Formwork Making		3601

Column Formwork Making

**Formwork Making – Course: Timberwork techniques. Trainees'
handbook of lessons**

Table of Contents

<u>Formwork Making – Course: Timberwork techniques. Trainees' handbook of lessons</u>	1
<u>1. Purpose and Use of Formwork</u>	1
<u>2. Functional and Load Requirements of Formwork</u>	2
<u>3. General Construction of Formwork</u>	4
<u>4. Types of Formwork</u>	6
<u>5. Preparation and Aftertreatment of Formwork</u>	10

Formwork Making – Course: Timberwork techniques. Trainees' handbook of lessons

Institut für berufliche Entwicklung e.V.
Berlin

Original title:

Arbeitsmaterial für den Lernenden
"Herstellen von Schalungen"

Author: Peter Wehrmann

First edition © IBE

Institut für berufliche Entwicklung e.V.
Parkstraße 23
13187 Berlin

Order No.: 93–35–3601/2

1. Purpose and Use of Formwork

The formwork serves as mould for concrete structural components unless such mould is provided by the soil, other structural components, etc. It moulds the placed fresh concrete, which in this stage normally is viscous, to the shape specified in the drawing.

Consequently, the formwork must already be available when the necessary steel reinforcement and concrete mix are placed. Proper making of formwork decides on the accuracy to size, strength and surface finish of the concrete components. Formwork is required wherever monolithic concrete and reinforced concrete structures or structural components are constructed, such as for

- solid structures (foundations, columns...),
- structures with special functions (containers, chimneys, hydraulic structures ...),
- structures to meet great static requirements (bridges, towers...),
- reconstruction of structures,
- public buildings and structures of irregular arrangement.

Generally, each formwork is of provisional nature and is to be removed after hardening of the concrete placed. The formwork is not to be built as strong as possible but as strong as necessary only!

Therefore, formwork stripping must always be kept in mind when erecting the formwork.

To avoid unnecessary difficulties of work and prevent damage from formwork parts, the following recommendations should be followed:

- Do not drive in too many nails.
- Use only as many timbers, braces, tie wires, etc. as necessary.
- Consider, which board, panel or squared timber is to be stripped first, to fix them so as to permit easy removal in the proper sequence.

Formwork making guaranteeing the necessary strength but also considering aspects of economical use of material and easy formwork stripping calls for extensive specialized knowledge of the direction of forces when placing the concrete mix.

Improperly made formwork, which gives way or breaks when the concrete is placed, results in heavy material damage or, in the worst case, may cause serious injury of persons.

On the other hand, an excessively strong formwork requires high physical efforts of the persons stripping the formwork and normally results in the complete destruction of the formwork parts.

2. Functional and Load Requirements of Formwork

Formwork functions

The formwork is the main means of work in the moulding process of the concrete. Basically the process of formwork making has to meet the following requirements:

- The structural component to be produced is to be moulded with the projected dimensions keeping the admissible tolerances.
- The dead loads of the fresh concrete and of the reinforcement as well as the temporary load of persons and working tools must be safely resisted and carried off to the soil or supporting members of the structure.
- The concrete must be protected against too high or too low temperatures as well as vibrations.
- The thin concrete mix must not flow out of the formwork.
- The future concrete component must have a surface finish meeting the required quality after stripping.
- The placement of necessary steel reinforcements must be easily possible during the erection of the formwork.
- Stripping of the concrete components produced must be uncomplicated.

What are the basic principles of formwork making?

Loading of vertical formwork

Vertical formwork is used for strip foundations, concrete walls and columns.

Immediately after placement in the formwork until achievement of its inherent stability, the concrete mix, under the effect of its own load and of compaction by vibration, exerts lateral pressure on the formwork which is called lateral pressure of the concrete mix.

The lateral pressure of the concrete mix depends on the following factors:

- Composition and properties of the concrete mix (density, type of cement, quality of concrete),
- concrete placing technology (concreting speed, compaction, vibration depth, total height of the concrete mix)
- ambient conditions (temperature, air humidity).

Tie wires (tie rods) are used to take up the lateral pressure of the concrete mix. They are to be included in the formwork project.

The maximum lateral load with external vibration occurs at the foot of the formwork and with internal vibration above the foot.

In addition to the lateral pressure of the concrete mix, the concrete mix also produces buoyant forces which may cause lifting of the formwork. This can be the case particularly with foundation formwork. To avoid this,

the formwork is to be anchored in the subsoil.

Another way is loading the formwork by means of concrete parts.

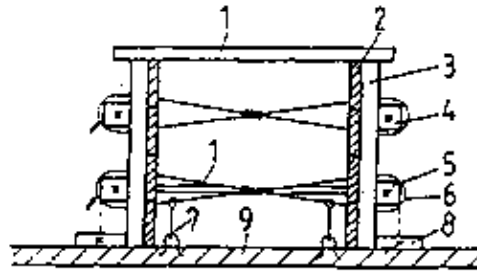

Figure 1 Formwork tying in the subsoil by means of tie wires

1 stulls, 2 sheeting boards, 3 post, 4 upper waler, 5 lower waler (additionally supported) 6 tie wire, 7 tying in the concrete bottom (tie wire), 8 thrust-board, 9 concrete bottom

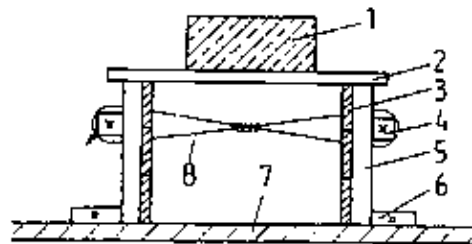

Figure 2 Formwork tying by loads on the formwork

1 concrete sheeting, 2 formwork bearer, 3 main bearer, 4 columns, 5 formwork pressure (surface pressure), 6 carrying off to the columns (linear)

What does the terms "lateral pressure of the concrete mix" mean?

Loading of horizontal formwork

Horizontal formwork is used for ceilings and beams. Horizontal formwork is subjects to vertical loads which are to be carried off to solid subsoils through formwork bearers and main bearers as well as columns.

Vertical loads are produced by

- the concrete mix weight in the specified height,
- reinforcements,
- concrete cones on the concrete pouring spot,
- concrete pouring impact on the formwork,
- persons and working tools,
- dead load of the formwork.

In addition to vertical loads, there are also horizontal loads which are produced by:

- wind effects
- inclined position of columns,
- backing up, etc.

The horizontal forces are taken up by auxiliary structures, such as braces and struts, or rigid connection to existing structural components, such as walls and columns.

Formwork walls and columns are to be backed up from all sides!

Through which components are vertical loads carried off?

3. General Construction of Formwork

The formwork sheeting (also called formwork shell)

The formwork sheeting is in direct contact with the concrete and can be considered as mirror image of the concrete components to be produced.

It is the moulding element of the formwork and has the greatest influence on the quality of the concrete surface.

The formwork sheeting has to resist heavy stress. It takes up surface pressure and carries it off to lineary acting supports.

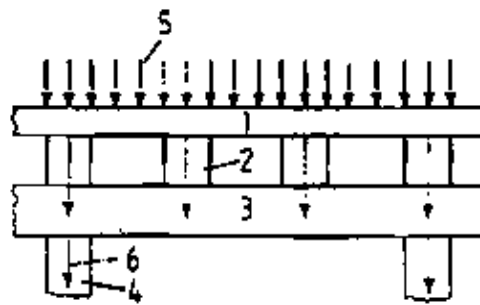

Figure 3 Formwork pressure distribution

1 formwork sheeting, 2 formwork bearer, 3 main bearer, 4 columns, 5 formwork pressure (surface pressure), 6 carrying off to the columns (linear)

It is typical of the formwork sheeting that, because of the heavy stress and direct contact with the concrete, it is the part of the formwork to wear first.

Sheeting boards and prefabricated wooden panels can be used as sheeting material.

Formwork sheeting of individual boards normally consists of 25 mm thick and approximately 140 mm wide boards. The heartwood side must always lie towards the concrete. Sheetting boards have great advantages because of their easy workability, such as by sawing, planing, boring and nailing.

Disadvantages are:

- the high expenditure of working time required for formwork making,
- the short service life,
- loss by waste wood.

In the event of repeated use of formwork of the same design, such as for foundation strips, sheetting panels can be prefabricated from individual boards using squared timbers as frame.

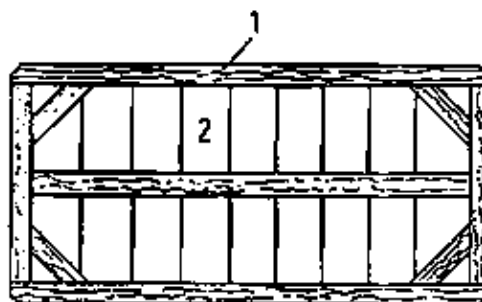

Figure 4 Sheetting panel for repeated use

1 sheeting panel frame, 2 holes for steel wedges

The sheeting panels are prefabricated in a workshop. The advantage of sheeting panels is that they considerably reduce the time required for the erection of the formwork on site.

The disadvantages of sheeting panels in terms of service life are similar to those of sheeting boards.

Normally both types of formwork sheeting are used on site in a combined manner.

What are the common types of formwork sheeting?

The formwork bearers

The formwork bearers directly support formwork sheeting. They carry off the forces through falsework structures to supporting members, the soil and formwork ties. The formwork bearers normally consist of squared timbers. The cross sections of the beams depend on the loads to be resisted. Because of their good workability, wooden beams have a wide field of application. In addition to wooden beams, prefabricated steel parts (steel beams, clamps etc.) are also used. Clamps are mainly used for column formwork.

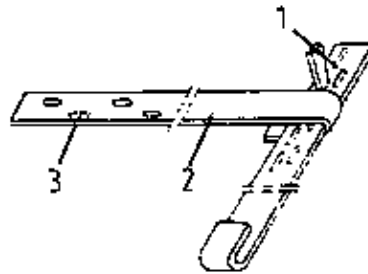

Figure 5 Steel clamp corner point for column formwork

1 steel wedge, 2 clamp, 3 holes for steel wedges

The formwork ties

With vertical formwork, the horizontally acting formwork pressure is mostly taken up by tying the two form-work faces to each other by formwork ties. It is done by slinging a steel wire (3.1 mm to 4.2 mm, annealed) around the formwork bearers, guiding it through boreholes in the formwork sheeting and tightening it by twisting. Immediately near the tie wire a stull (of wood or concrete) is to be mounted to maintain the necessary width of formwork.

When placing the concrete, the stull (if made of wood) is to be removed because the concrete mix assumes the bracing function (pressure) (See Fig. 1 and Fig. 2).

Another way of bracing is screwing by means of steel screws.

The elements of falsework structures

Falsework structures are those parts of the formwork which take up and carry off the load from the formwork sheeting and formwork bearers.

The main elements of such formwork structures are columns and main bearers.

The column takes up the load directly from the formwork bearer and carries it off.

Round timber braces and specially made metal tube structures adjustable in height may be used as columns.

In the case of round timber columns, double wedges are to be placed at the foot to prevent lowering of the formwork when stripping.



Figure 6 Column foot with wedge support

1 column, 2 wedge support

Other falsework elements are the main bearers which are horizontally arranged. One main bearer takes up the load from several formwork bearers and carries it off to the columns. Main bearers can be made of amply dimensioned squared timbers. But they may as well consist of metal tube structures of lattice type.

Lattice-type metal tube structures are indispensable for big widths where columns cannot be laced at close intervals.

Further falsework elements are bracing members which are required for both vertical and horizontal form-work. They ensure that the admissible unsupported length of columns is kept and secure the formwork against displacement and canting.

Their arrangement and fixing according to the project is decisive for the stability of the formwork.

Bracing members may be:

- boards, squared timbers and round timbers,
- metal tube structures, steel ropes and steel sections.

How is dimensional inaccuracy by compression of the formwork prevented by means of tie wires?

What is a falsework structure?

4. Types of Formwork

4.1. Foundation Formwork

Foundation formworks can be designed in various ways. Basically there is a difference between formwork for individual foundations, normally designed as socket foundations, and formwork for strip foundations. The type of design is dictated by the size, mainly by the height of the foundation formwork.

The formwork for individual foundations is similar to column formwork and the formwork for strip foundations is similar to the formwork.

Normally sheeting panels with formwork bearers in the form of walers are used for foundation formwork. Individual foundations are also secured by means of walers but of rim type.

Bracing is by squared and round timbers as well as boards diagonally arranged. Tie wires as well as metal screws are used as formwork ties.

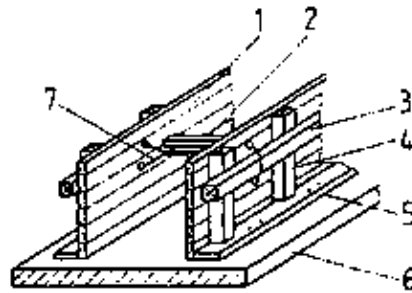

Figure 7 Foundation formwork

1 formwork sheeting, 2 sill, 3 waler, 4 post, 5 thrust-board, 6 concrete bottom, 7 tie wire

How is lifting of a foundation formwork prevented?

4.2. Wall Formwork

Wall formwork consists of vertically arranged upright timbers (formwork bearers) to which sheeting boards are nailed at the concrete side. The upright timbers are diagonally braced by means of boards at both sides.

On cleats situated at every third upright timber, there are horizontally arranged walers. The opposite walers are tied at specified distances.

Prefabricated sheeting panels may also be used instead of sheeting boards.

Cleaning holes are to be provided at the foot of the formwork.

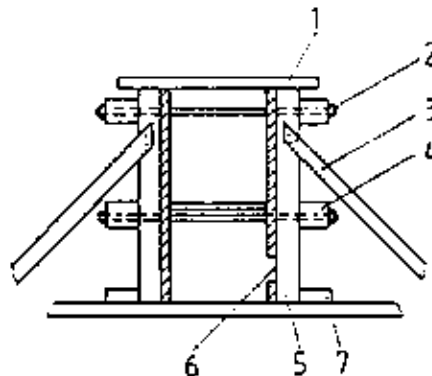

Figure 8 Wall formwork (vertical section)

1 sill, 2 screw tie, 3 bracing, 4 waler 5 post, 6 cleaning hole, 7 thrust-board

4.3. Ceiling Formwork

Ceiling formwork is the type of formwork mostly found in structures/buildings.

The formwork sheeting may consist of sheeting boards or prefabricated sheeting panels. The formwork sheeting lies on squared timber formwork bearers which are arranged on main bearers carrying off the forces to round timber columns. With smaller rooms, the main bearer together with two columns form a trestle. Diagonal board bracings are provided to take up horizontally acting forces. The round timber columns are placed on double wedges which serve as stripping aid and correction device.

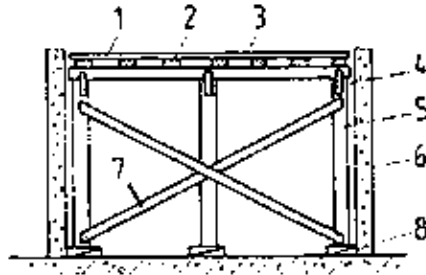

Figure 9 Ceiling formwork (vertical section)

1 formwork sheeting, 2 formwork bearer, 3 main bearer, 4 cleat, 5 column, 6 wall, 7 bracing, 8 support wedges

Which auxiliary means is used to facilitate stripping of the columns?

4.4. Beam Formwork

Beam formwork has prefabricated formwork sheeting parts (sheeting bottom and side sheeting panels). Such individual parts are manufactured based on the beam dimensions specified in the project. For prefabrication of the formwork sheeting parts, a special preparation table must be manufactured on site.

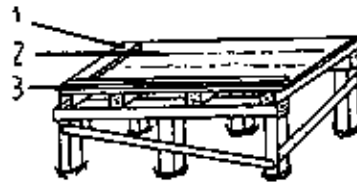

Figure 10 Preparation table

1 square strip, 2 post, 3 stop rail

The sheeting bottom and the side panels consists of sheeting boards nailed together by means of cover straps. Depending on the size of the beam, the width of the sheeting bottom is dimensioned so as to accept, at both sides of the width of the reinforced concrete column, the thickness of the sheeting and cover straps and the width of a thrust-board (approximately 100 mm).

The sheeting bottom can be placed on a pedestal support (a trestle formed by a waler connected with two columns by means of cleats) or on a round timber column also supporting a waler with cleat connection. In the latter case, the round timber column is located under the centre of the beam. By diagonal board bracing the round timber column and the waler above it, a composite triangle is formed. The side sheeting is erected on the sheeting bottom and held by a thrust-board.

At the upper edge of the side sheeting a waler is mounted at both sides holding together the formwork by wire or spindle ties.

A stull-batten is to be nailed on the formwork immediately above the ties to ensure that the projected beam width is kept when tying the formwork.

The waler and the columns are additionally braced by diagonal boards.

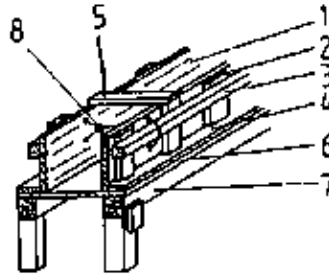

Figure 11 Beam formwork

1 side panel, 2 cover strap, 3 waler, 4 thrust-board, 5 stull, 6 formwork bottom, 7 trestle, 8 tie wire

What is the minimum width a sheeting bottom of beam formwork must have?

4.5. Column Formwork

Similar to beam formworks, the sheeting of column formworks is prefabricated according to the column dimensions from sheeting boards connected by cover straps.

The sheeting panels are placed in a foot rim which is anchored in the soil by steel bolts.

The foot rim consists of double-nailed boards. The foot rim must be exactly measured-in because it is decisive for the exact location of the column. It has the same functions as the thrust-board for foundation or beam formwork.

When the sheeting panels have been inserted in the foot rim, vertical arch timbers are placed to take up the forces from the cover straps of the formwork sheeting.

Around the arch timbers, which have the function of walers, column clamps of flat steel are clamped with wedges or a rim of boards is arranged similar to the foot rim. Additional formwork tying by tie wires or steel screws is not necessary.

The distances of the clamps are specified in the formwork project. Normally they are approximately 700 mm.

The column in the formwork is laterally tied by diagonal board braces.

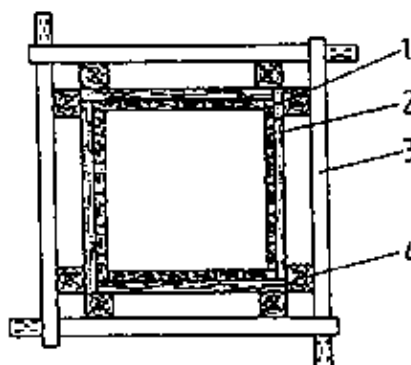

Figure 12 Column formwork (horizontal section)

1 formwork sheeting, 2 cover strap, 3 clamp, 4 arch timber

A lateral cleaning hole is to be provided at the foot of the formwork for removal of any impurities in the form-work before the concrete is placed.

If a steel reinforcement is to be erected in the column formwork, two sides of the column only are to be provided with formwork first to permit easy erection of the reinforcement. After erection of the reinforcement, the remaining two sides of the column formwork can be mounted.

The two sides mounted first are to be arranged cornerwise to ensure provisional stability.

How can impurities in the column formwork be removed?

5. Preparation and Aftertreatment of Formwork

Before placing the concrete, the formwork is to be cleaned and checked again for proper execution.

After cleaning, the cleaning holes of wall and column formworks are to be tightly closed since the maximum pressure of the concrete mix is occurring at the foot of the formwork where the cleaning holes are situated. For this purpose, the sheeting pieces of the cleaning holes are always to be put against the thrust-board and against formwork bearers. If necessary, additional formwork bearers are to be mounted. Immediately before concreting, the formwork is to be thoroughly wetted with water because thereby less water will be extracted from the concrete mix and later stripping will be facilitated. When placing the concrete, it is to be made sure that no changes take place with the formwork.

Stripping of the formwork must not be started unless the site engineer in charge has given the respective express instructions. Too early removal of the formwork parts may cause heavy damage to the structure and/or injury of persons.

Stripping is to be done very carefully. Neither the concrete nor the formwork timbers must be damaged. Emergency columns are the last to be removed. When stripping, greatest attention is to be attached to the structural direction of forces of the formwork. All nails are to be removed from the stripped formwork timbers, and the stripped timbers are to be cleaned and overly stacked. The strict observance of labour safety regulations is of special importance for stripping work because of the danger of falling-down formwork parts.

Making of Parquetry – Course: Timberwork techniques. Instruction examples for practical vocational training

Table of Contents

<u>Making of Parquetry – Course: Timberwork techniques. Instruction examples for practical vocational training</u>	1
<u>Preliminary Remarks</u>	1
<u>Instruction Example 7.1.: Determining the Material Requirement of Single Parts of Parquetry for a Given Room</u>	1
<u>Instruction Example 7.2.: Laying of Mosaic Parquetry</u>	6
<u>Instruction Example 7.3.: Laying of Parquetry – Technique: pasted on solid ceiling, belt or ship’s bottom pattern, parquetry–fillet with fixed tongue</u>	10
<u>Instruction Example 7.4.: Laying of Parquetry – Technique: nailed on planed boarded floor, belt or ship’s bottom pattern, parquetry–fillets with movable tongues</u>	14
<u>Instruction Example 7.5.: Finishing and Sealing of Parquetry</u>	17

Making of Parquetry – Course: Timberwork techniques. Instruction examples for practical vocational training

Institut für berufliche Entwicklung e.V.
Berlin

Original title:
Lehrbeispiele für die berufspraktische Ausbildung
“Herstellen von Parketts”

Author: Peter Wehrmann

First Edition © IBE

Institut für berufliche Entwicklung e.V.
Parkstraße 21/23
13187 Berlin

Order No.: 93–33–3607/2

Preliminary Remarks

The present material includes 5 selected instruction examples on the basis of which the laying of parquetry can be practised.

The instruction examples are organized in such way that by solving the tasks of the first example the material in the form of parquetry–fillets required for the second, third and fourth examples is determined.

In the course of the instruction examples 2–4, the various operations of laying of parquetry are carried out.

Instruction Example 7.5. deals with the finishing of parquetry.

In order to facilitate the preparation and carrying out of the respective operations, the materials, tools, measuring and testing means as well as auxiliary accessories required for each instruction example are indicated.

Furthermore, the basic knowledge is mentioned which is required besides mastering the technique “Making of Parquetry”. It is recommended to repeat this basic knowledge before starting the exercises.

Observing the given sequence of operations will result in a good quality of work.

A working drawing is attached to each instruction example, that will facilitate the technological approach.

The fixing of the skirting board is not explained in the present instruction examples. Information on this can be taken from the material on “Making of Floors”.

Instruction Example 7.1.: Determining the Material Requirement of Single Parts of Parquetry for a Given Room

Practising material calculations for determining the required number of single parts of parquetry.

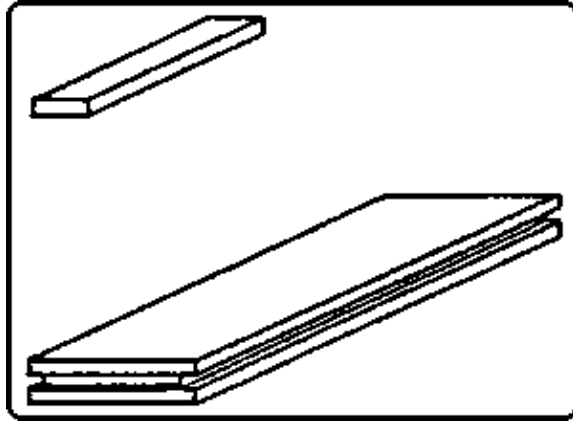

Measuring and testing means

Folding rule, steel tape measure

Auxiliary accessories

Pocket calculator, paper, pencil

Required basic knowledge

Using length measuring instruments, mastering fundamental operations such as multiplying and dividing

Explanations to the working drawing

- 1 Mosaic parquetry–fillet
- 2 Parquetry–fillet
- 3 Surface of the room to be calculated

Sequence of operations	Comments
1. Preparing writing paper, pencil and measuring equipment.	Taking this equipment to the room that shall be measured.
2. Measuring the dimensions of the room and writing them down on a hand drawing.	Making the free–hand sketch in the room itself (“on the spot”).
3. Calculating the surface of the room	The calculations should be made at a working table with seats. Using a pocket calculator is recommended.
<u>given:</u> – dimensions of the room – dimensions of the surfaces of the parquetry–fillets	
<u>to be determined:</u> – required number of mosaic parquetry–fillets – required number of parquetry–fillets	
$F_1 = a \cdot b$ $F_1 = 5030 \text{ mm} \cdot 5500 \text{ mm}$ $F_1 = 27\,650\,000 \text{ mm}^2$	$F_1 =$ surface without recess (total)
$F_2 = a \cdot b$ $F_2 = 2100 \text{ mm} \cdot 2600 \text{ mm}$ $F_2 = 5\,460\,000 \text{ mm}^2$	$F_2 =$ surface of the recess
$F_R = F_1 - F_2$ $F_R = 27\,650\,000 \text{ mm}^2 - 5\,460\,000 \text{ mm}^2$ $F_R = 22\,190\,000 \text{ mm}^2$	$F_R =$ surface of the room (real)

4. Calculation of the surface of the given mosaic parquetry–fillet	
$F_{MP} = b \cdot l$ $F_{MP} = 20 \text{ mm} \cdot 120 \text{ mm}$ $F_{MP} = 2\,400 \text{ mm}^2$	F_{MP} = surface of the mosaic parquetry–fillet
5. Calculation of the surface of the given parquetry–fillet	
$F_{SP} = b \cdot l$ $F_{SP} = 60 \text{ mm} \cdot 400 \text{ mm}$ $F_{SP} = 24\,000 \text{ mm}^2$	F_{SP} = surface of the parquetry–fillet
6. Calculation of the required number of mosaic parquetry–fillets	
$MP = F_R : F_{MP}$ $MP = (22\,205\,000 \text{ mm}^2) / (2\,400 \text{ mm}^2)$ $MP = \underline{9252.08}$	MP = mosaic parquetry–fillet
9300 mosaic parquetry–fillets are required.	Rounding the number up is necessary because waste material must be considered.
7. Calculation of the required number of parquetry–fillets	
$SP = F_R : F_{SP}$ $SP = (22\,205\,000 \text{ mm}^2) / (24\,000 \text{ mm}^2)$ $SP \underline{925.21}$	SP = parquetry–fillet
950 parquetry–fillets are required.	

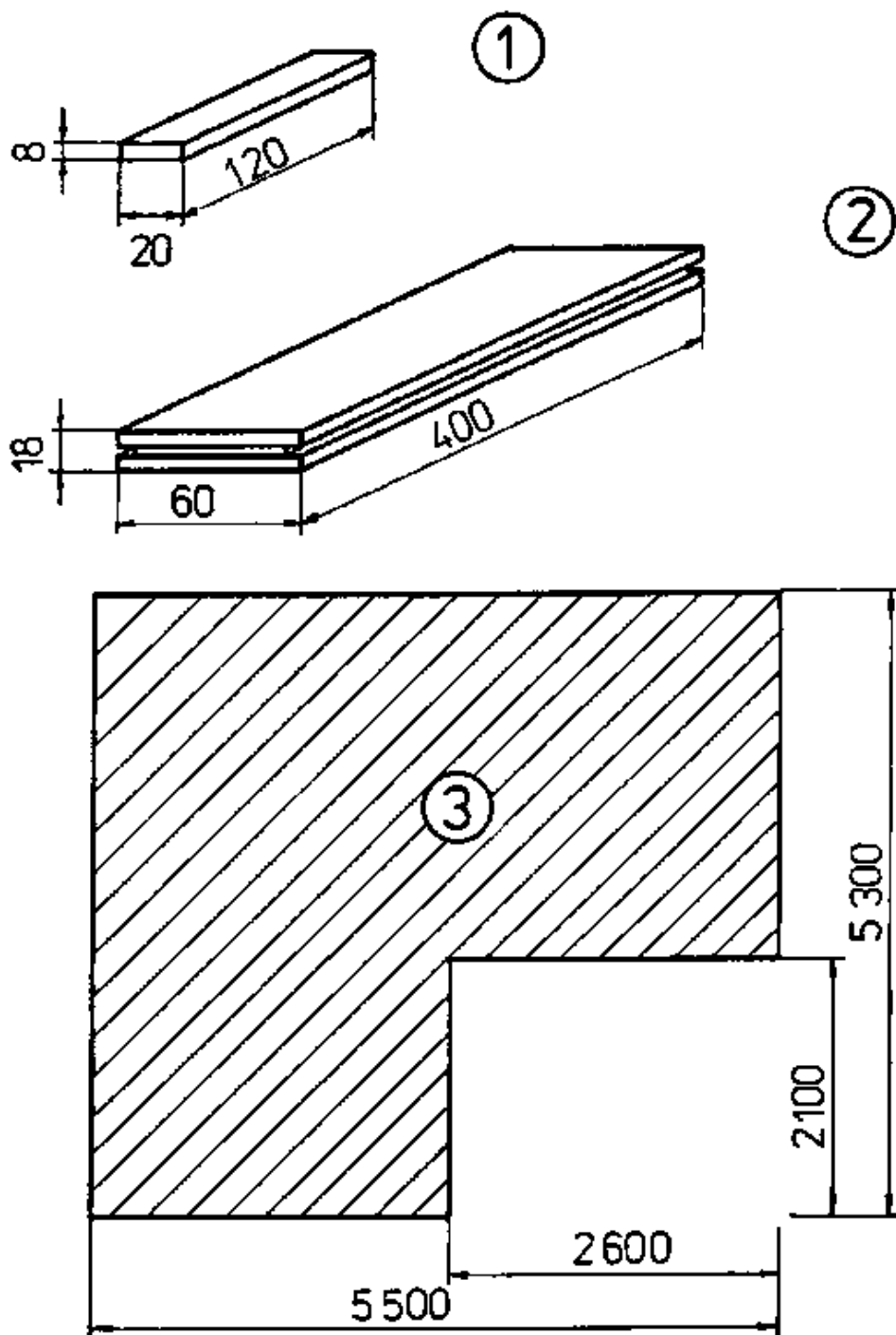

				7.1.
FBE	Single parts of parquetry			3607

Instruction Example 7.2.: Laying of Mosaic Parquetry

Technique: pasted on solid ceiling

Practising of mosaic parquetry laying

Material

Mosaic parquetry–fillets, parquetry adhesive, adhesive thinner

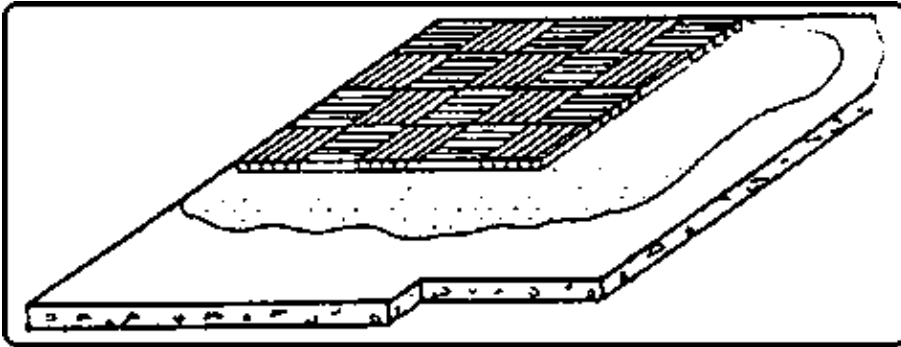

Tools

Hand saw, hammer, plane, broom, pushing and drawing scrapers

Measuring and testing means

Try square, flat square, folding rule, pencil, water–level, pipe–level

Auxiliary accessories

Bucket, string, steel bolts, knee pad

Required basic knowledge

Scribing, sawing, adhesive processing, laying of building components along a string, jointing

Explanations to the working drawing

1 subfloor, 2 adhesive bed, 3 mosaic parquetry, 4 string, 5 distance to the wall, 6 steel bolt, 7 1st laying direction, 8 2nd laying direction

Sequence of operations	Comments
1. Checking the subfloor for strength, moisture content and horizontal surface.	Subfloor must be free of cracks, firm, retain a constant volume and be <u>dry</u> . The horizontal surface has to be checked with the help of a pipe–level, straight–edge or water–level.
2. Taking small parquetry–fillets, as many as required (vis. instruction example 1), and transporting them to the place of use,	Faulty fillets are sorted out, processing losses have to be considered.

3. Drawing off adhesive and thinner and transporting them to the place of use.	Attention! Pay attention to the instructions of the manufacturer – often toxic or injurious to health.
4. Preparing tools and auxiliary accessories and arranging the working place.	Make sure that the equipment is complete.
5. Cleaning the subfloor with broom, if necessary with pushing scraper; removing the dirt.	
6. Preparing primary coat and spreading it.	Primary coat is made from thinned adhesive and is applied by sectors, evenly and over the entire surface of each sector by a drawing scraper. Observe regulations on health protection: Knee-pad, risk of splashing in the eyes, of acid skin burn, of poisonous and sometimes inflammable vapours.
7. Distributing the small parquet-fillets and putting up a string for alignment. (Vis. working drawing)	Pay attention to the angles and to parallelism.
8. Spreading the adhesive with the drawing scraper and putting the small parquet-fillets on the adhesive coat by sectors. Pressing the fillets on firmly and accurately along the string and fixing them by slight hammer blows.	When laying the fillets, observe the intended pattern. Be absolutely accurate along the alignment string. Replace faulty fillets, consider colour and grain deviations.
9. Cleaning the working place.	Remove replaced fillets etc., clean the tools, close vessels and take all this out of the room. Let the parquet set for at least 2 days.

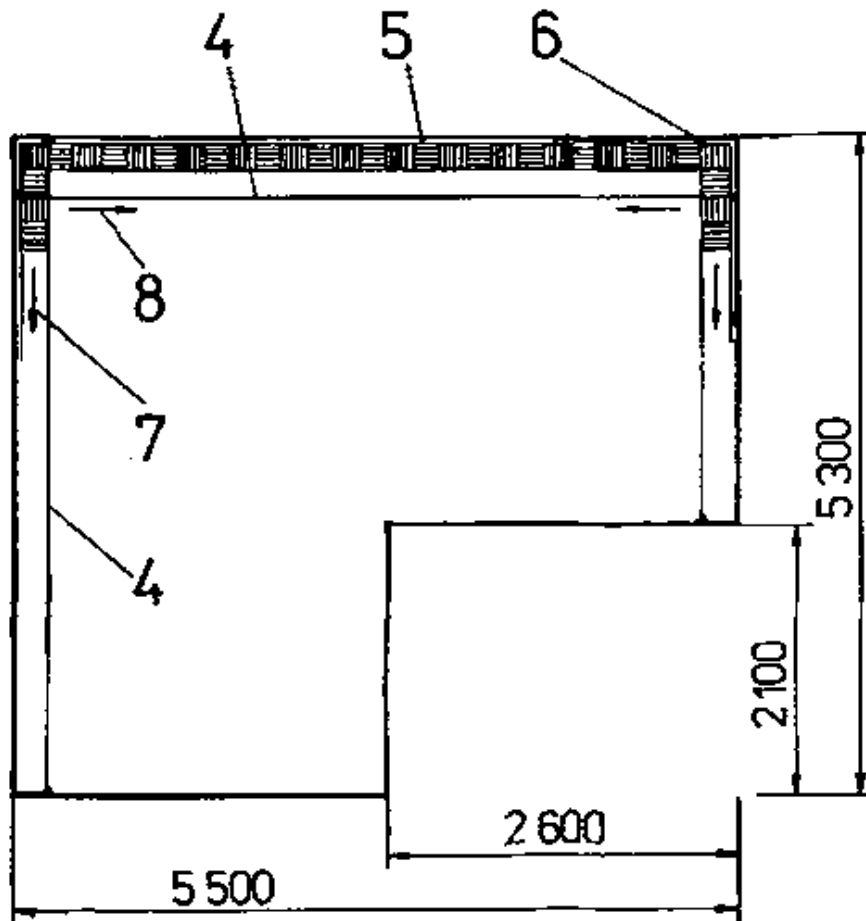
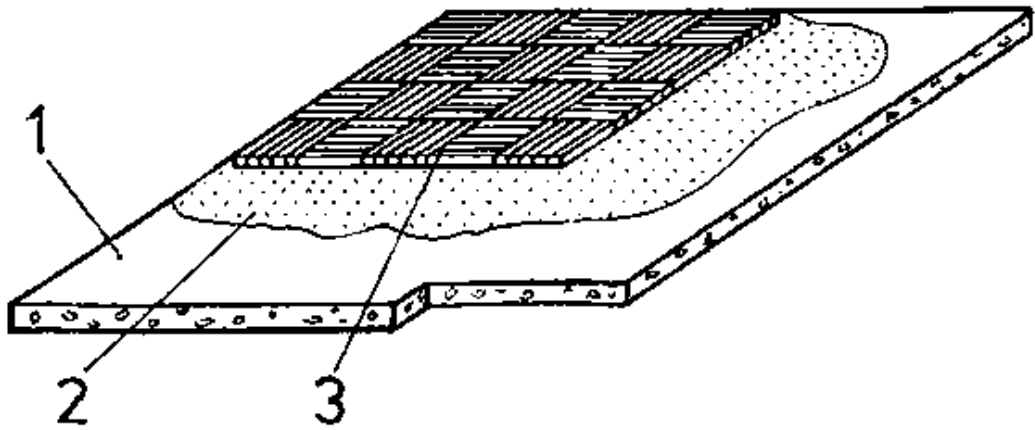

			7.2.
FBE	Mosaic parquetry-fillets		3607

Instruction Example 7.3.: Laying of Parquetry – Technique: pasted on solid ceiling, belt or ship’s bottom pattern, parquetry–fillet with fixed tongue

Practising of parquetry laying according to the above mentioned technique.

Material

Parquetry–fillets, parquetry adhesive, adhesive thinner, sealing cardboard such as bituminous felt, bare, cold glue for wood.

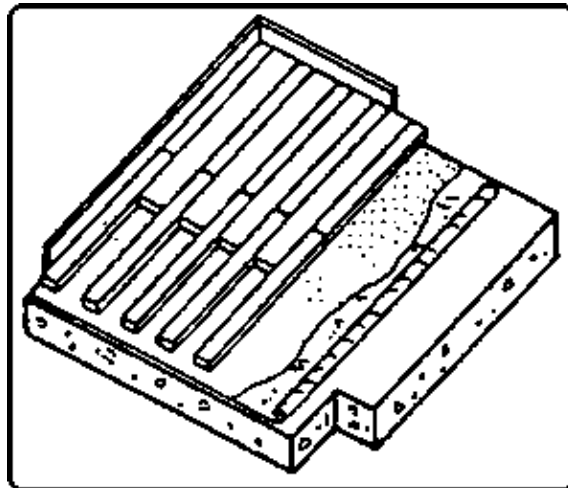

Tools

Hans saw, circular saw bench, hammer, plane, tow hook, broom, pushing scraper, drawing scraper

Measuring and testing means

Try square, flat square, folding rule, pencil, water–level, pipe–level

Auxiliary accessories

Bucket, string, steel bolt, knee pad

Required basic knowledge

Scribing, sawing, glue processing, laying of construction elements along the string, jointing

Explanations to the working drawing

1 parquetry, 2 skirting board, 3 glue bed, 4 bituminous felt, 5 subfloor, 6 string, 7 distance to the wall, 8 steel bolt, 9 bituminous felt webs, 10 1st laying direction, 11 2nd laying direction

Sequence of operations	Comments
1. Checking the subfloor of the parquetry.	
2. Cleaning the subfloor carefully with hair broom and pushing scraper.	All foreign parts that can be made loose must be carefully removed.

3. Filling the glue in a bucket and transporting it to the working site together with the sealing cardboard.	Be careful when using glue, pay attention to the instructions of the manufacturer.
4. Unwinding sealing cardboard and cutting it to length.	The length of the webs must correspond to the dimensions of the room.
5. Laying of the cut webs with the lateral seams edge to edge, and fitted to recesses and projections.	The webs must not overlap in any place.
6. Rolling the unwound webs back to the middle of the respective web and – after the primary coat has been applied according to Instruction Example 7.2. – spreading the glue with the drawing scraper, rolling the webs in place again, pressing them on and rubbing them into the glue.	On the opposite end of the webs the sequence of operations is analogous.
7. Putting up the string for the first two fillet rows on the steel nails driven in before, joining approximately 1 m of the length of the fillet row with the laying hammer (dry), putting the prepared piece under the string into the bed of glue, pressing it on and aligning it with the help of the string.	The string must be put up angularly and parallel to the room. Leave an air gap of 20 mm along the wall.
8. At the end of the two rows marking top cut, cutting with saw and laying with tow hook.	Before that, the last 3 fillets must get a cold glue coating on the head end.
9. Further laying of the parquetry rows along the string and by analogy to the first two rows.	Aligning the laid parquetry fillets in the direction of the wall – check for horizontal position!
10. Remaining space to be covered with parquetry: If required, scribing longitudinal cut, cutting with circular saw bench and laying with tow hook.	Coat the last 3 fillets with cold glue on the longitudinal sides before.
11. Cleaning the working site.	

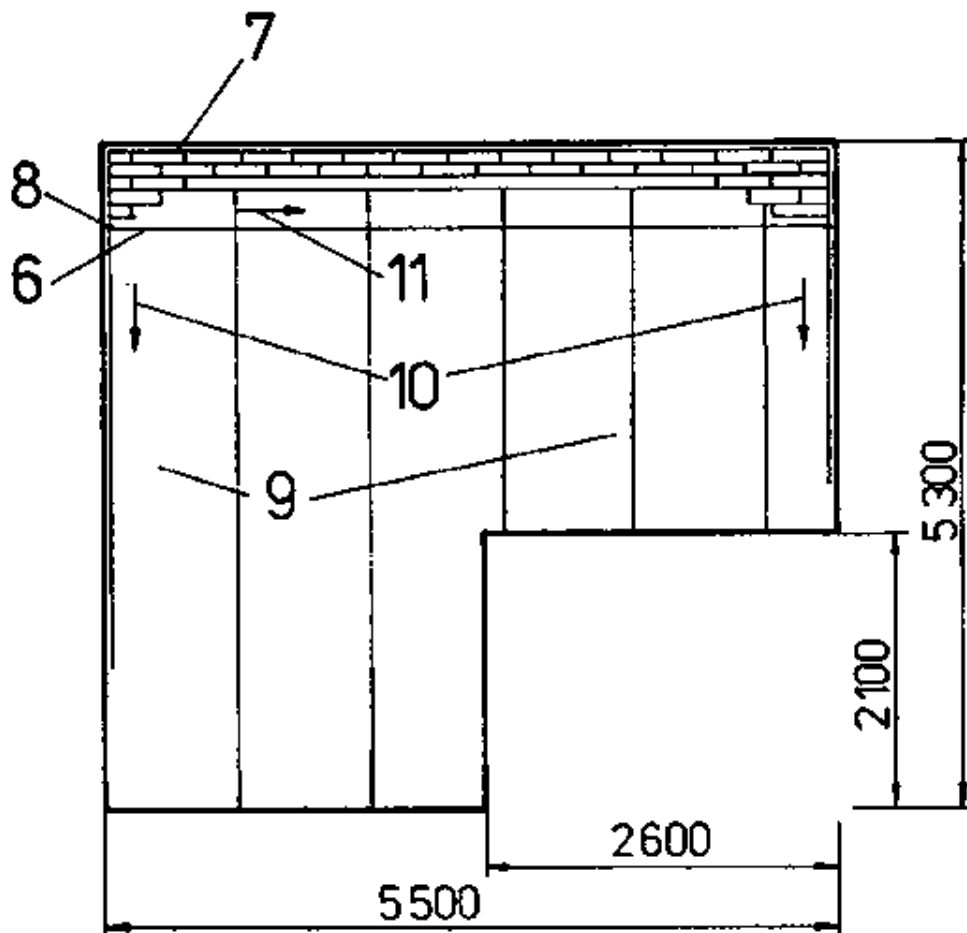
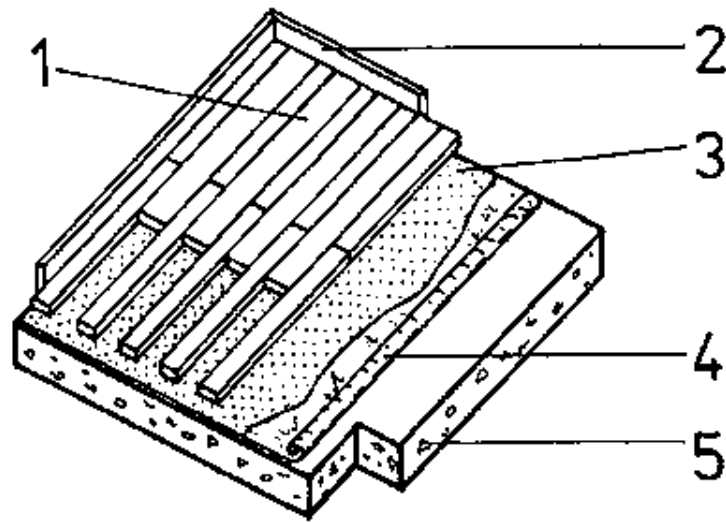

			7.3.
¹³ IBE	Parquetry-fillets (pasted)		3607

Instruction Example 7.4.: Laying of Parquetry – Technique: nailed on planed boarded floor, belt or ship’s bottom pattern, parquetry–fillets with movable tongues

Practising of parquetry laying according to the above technique.

Material

Parquetry–fillets with tongues, countersunk nails
(2 pieces per fillet)

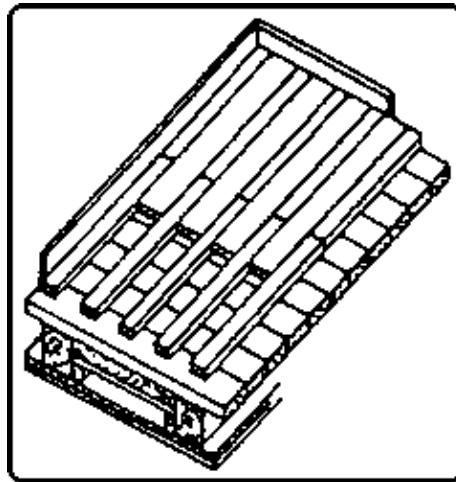

Tools

Hand saw, circular saw bench, hammer, nail tongs, plane, tow hook, nail punch, broom

Measuring and testing means

Try square, flat square, folding rule, pencil, water–level, pipe–level

Auxiliary accessories

String, steel bolts, knee pad

Required basic knowledge

Scribing, sawing, laying of building components along the string, jointing

Explanations to the working drawing

1 Skirting board, 2 parquetry, 3 planed deals, 4 timber beam, 5 ceiling structure, 6 string, 7 planed boarding, 8 steel bolt, 9 1st laying direction, 10 2nd laying direction, 11 1st layer of parquetry–fillets, 12 nailing of two sides (1st layer)

Sequence of operations	Comments
1. Testing the wooden subfloor as to strength, moisture and vermin infestation.	The deals must be firmly nailed, must not project or be moist and must be free of vermin.
2. Sweeping the subfloor clean and removing the dust.	

3. Fixing the middle row and putting up the string along the middle row stretching it with the help of the steel bolts.	String must be angular and parallel to the wall.
4. Distributing the parquetry–fillets and putting in the tongues on one head end.	Sort out faulty parquetry–fillets when distributing them.
5. Laying the middle row of parquetry–fillets along the string and nailing them on the subfloor on both sides with two nails per fillet, scribing the head–end cut, sawing it and laying it with the help of the tow hook, coating the last three head ends with cold glue before.	The nails are driven obliquely into the rabbet. The nails are countersunk with the nail punch, so that in the rabbet no nail is in the way when the tongue is put in.
6. Distributing the required parquetry–fillets on the left and right sides of the middle row and putting the tongues in the fillets.	One tongue in one head end and longitudinal side, each.
7. Removing the string from the middle row and continuing to lay parquetry–fillets along the middle row, nailing each external end with 2 nails on the subfloor.	
8. Cut final row, if required, longitudinally; therefore scribing, cutting to length and laying with tow hook. Coating the sides of the last row with cold glue before.	Leaving an air gap of 20 mm along the wall.
9. Cleaning the working place.	

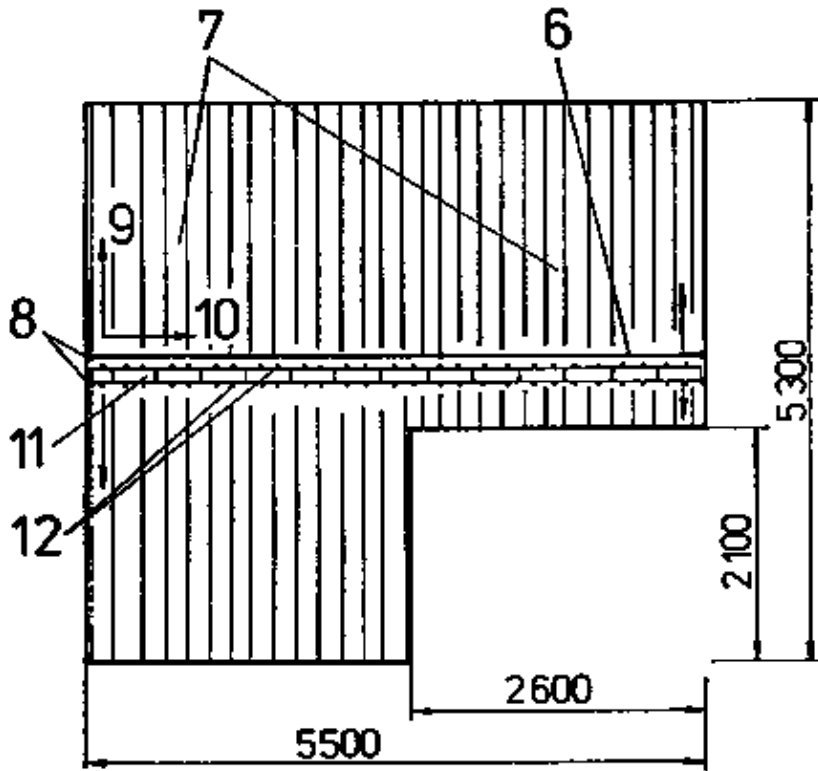
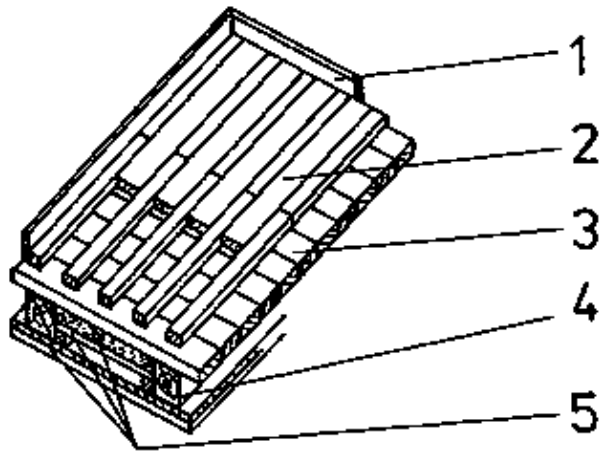

				7.4.
IBE	Parquetry-fillets (nailed)			3607

Parquetry-fillets (nailed)

Instruction Example 7.5.: Finishing and Sealing of Parquetry

Practising of parquetry finishing and sealing irrespective of the type of parquetry

Material

Parquetry sealing lacquer, thinner, joiner's putty

Tools

Broom, brush, paint roller, abrasive paper, sandpaper block, pushing scraper, grinder

Auxiliary accessories

Bucket, can

Required basic knowledge

Handling a grinder, working with parquetry sealing lacquers and knowledge of their properties, coating methods

Sequence of operations	Comments
1. Once again cleaning parquetry thoroughly with broom, detecting small faults.	
2. Reworking faulty spots, such as cracks, knots and defective edges with the help of scraper and joiner's putty.	If – in spite of the careful selection of the parquetry–fillets – there should be deeper holes or defects, the joiner's putty is applied in layers.
3. Smoothing the floor with the grinder in circular motions until an even and plane surface is achieved.	When grinding, make sure that no corrugations appear.
4. Sweeping smoothed floor carefully.	Do only walk with soft and clean shoes on smoothed floor.
5. Putting on the first layer of the sealing lacquer – along the edges with brush, in the middle with paint roller.	When applying the lacquer coat make sure that no foreign bodies, such as shavings or rough particles of dust, are left under the lacquer coat.
6. After the first coating has dried, smoothing minor imperfections such as wood fibres that were put upright by fine–grained abrasive paper. Removing grinding dust carefully.	First coat will have dried after approximately 24 hours.
7. Applying two other coats of sealing lacquer at the appropriate intervals.	If required, unevennesses can be smoothed again here and there.
8. Cleaning the working place.	Painting tools are washed in thinner.

**Making of Parquetry – Course: Timberwork techniques. Trainees'
handbook of lessons**

Table of Contents

<u>Making of Parquetry – Course: Timberwork techniques. Trainees' handbook of lessons</u>	1
<u>1. Purpose and Importance of Parquet Floor</u>	1
<u>2. Tools for Laying Parquet Floor</u>	2
<u>3. Types of Parquetry, Use of Materials and Hints on Design</u>	3
<u>4. Advice for and Rules with Making Parquet Floors</u>	7
<u>4.1. Preparation of the Subfloor</u>	8
<u>4.2. Laying of Parquet</u>	10
<u>4.3. Dressing</u>	11

Making of Parquetry – Course: Timberwork techniques. Trainees' handbook of lessons

Institut für berufliche Entwicklung e.V.
Berlin

Original title:
Arbeitsmaterial für den Lernenden
"Herstellen von Parketts"

Author: Peter Wehrmann

First Edition © IBE

Institut für berufliche Entwicklung e.V.
Parkstraße 21/23
13187 Berlin

Order No.: 93–35–3607/2

1. Purpose and Importance of Parquet Floor

Parquetry belongs to the category of floor covering, like, for instance, planed boarding, plastic coverings, fleximer flooring and ceramic flooring.

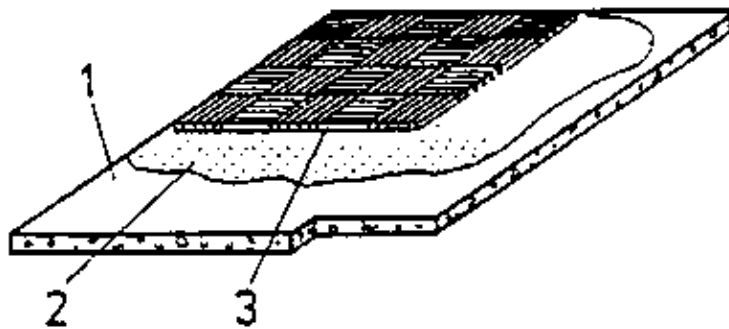

Figure 1

Parquetry

1 subfloor, 2 adhesive bed, 3 mosaic fillet

It is the immediately utilized layer of the floor. The selection of the flooring to be laid is determined by the various demands the future use of the floor will make. The most important requirements on floorings and the qualities of parquetry are mentioned below:

Technical demands

(Compressive and flexural strength as well as wear resistance)

In this respect, parquetry shows the best properties and greatest resistance to wear. Its service life, for example in a living-room, hotel room or office lasts for more than 60 years.

Physical demands as to construction engineering

(Thermal and sound insulation, protection against moisture)

Here, too, parquetry proves to be the best possible solution, with its properties, as a rule, being far better than those of any other types of flooring, except moisture protection.

Technological demands

(Time of manufacture, time of drying, period of time till the floor can be used)

Here the properties of parquetry are unfavourable. Parquet laying requires a complicated sequence of operations:

It must be prepared on special machines, and the laying and entire trimming of it again requires much time. Another and rather long period must pass till the floor can be used. This waiting period is longer than with other types of flooring.

Economic demands

(Parquetry is the most expensive flooring as to material and manufacture)

The wood used for this purpose must meet great requirements with respect to strength and aesthetical qualities.

Premanufacture as well as laying require much time and labour.

Demands on design

(Appearance, total easthetical effect on the design of the room)

Here, parquetry meets highest standards. By suitable patterns and selected kinds of wood, parquet floor can have and excellent effect on the design and atmosphere of a room.

Fields of application of parquetry

Parquetry may be used in housing and social construction as well as in industrial building, for instance in

- gymnasias
- restaurants
- arts centres
- flats
- production rooms in light industry, etc.

What are the essential qualities of parquet floor?

How long does the service life of a parquet floor last with normal utilization?

2. Tools for Laying Parquet Floor

The below mentioned tools relate to the laying of premanufactured parquetry only.

The making of parquetry–fillets, elements, etc. requires special wood processing machines.

The following working means are required for laying different kinds of parquet floors:

Measuring, marking and testing instruments

- Folding rule, pencil
- Flat and try squares
- Pipe–level
- Water–level
- String

Tools for parquet laying

- Hand saws
- Hammers
- Nail tongs
- Plane
- Nail punch
- Mallet
- Abrasive paper
- Files
- Tow hooks

Tools for preparing the subfloor, as well as for applying the adhesive and the sealer coat

- Broom
- Putty knife (pushing) Putty knife (drawing)
- Brush
- Paint roller

Other equipment

- Grinding machine
- Cans and buckets for adhesive and sealer coat storage and processing
- Carpenter's bench
- Protective clothing (knee protection)

3. Types of Parquetry, Use of Materials and Hints on Design

The **types of parquetry** are categorized as follows:

Parquet floor

It consists of parquetry–fillets. The parquetry–fillets are pieces of wood made from raw slats, rectangular, with key and slot and with plane–parallel top and bottom surfaces.

The minimum thickness is 16 mm.

It is distinguished between:

Parquetry–fillet with fixed key

Parquetry–fillet having a key at two of its narrow surfaces and a slot in the other two narrow surfaces.

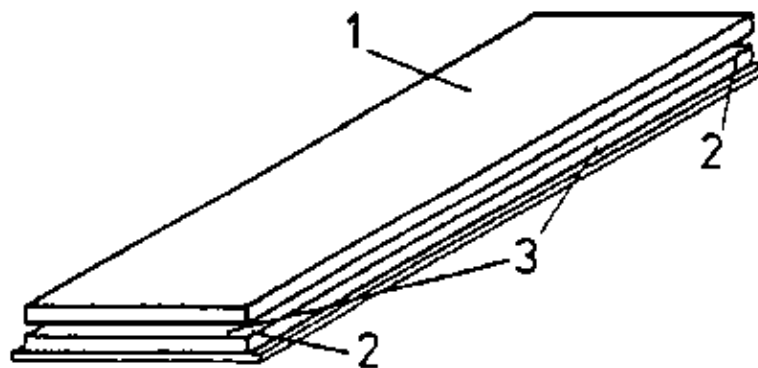

Parquetry–fillet with fixed tongue

1 wear layer, 2 groove, 3 tongue

Parquetry–fillet with loose key

Parquetry–fillet in which a slot is cut in all its narrow surfaces to receive loose keys.

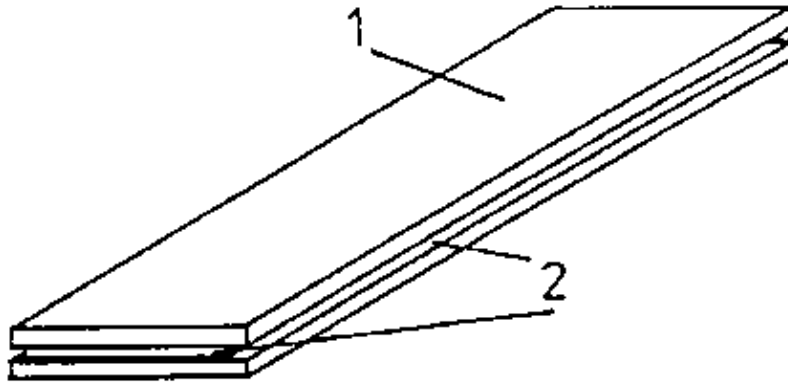

Figure 3

Parquetry–fillet with loose tongue

1 wear layer, 2 groove

Parquetry elements

Premanufactured wood element, large and mostly self–supporting, consisting of several layers which are glued to one another, and showing profiled narrow surfaces.

It is distinguished between:

Parquet board

Element of parquetry of a rectangular shape the third layer of which mostly consists of mosaic parquetry.

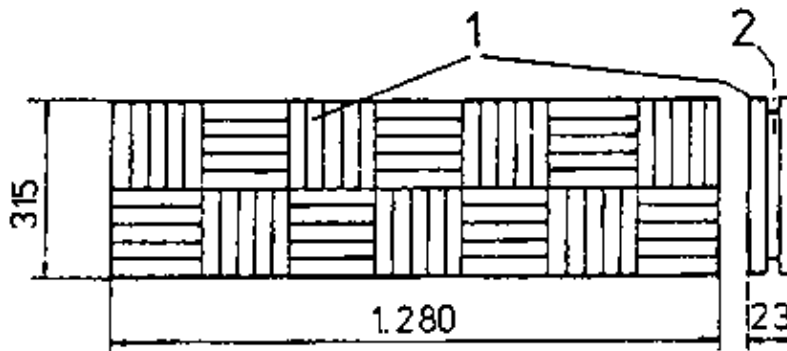

Figure 4

Parquet deal

1 wear layer from mosaic fillets, 2 groove

Parquet panel

Element of parquetry of a square shape, the third layer of which mostly consists of mosaic parquetry.

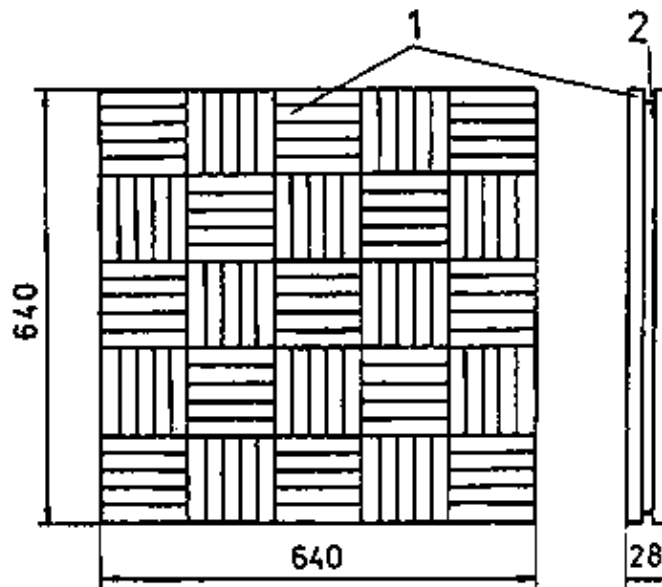

Figure 5

Parquet panel

1 wear layer from mosaic fillets, 2 groove

Mosaic parquetry

A part of parquetry made from mosaic parquetry–fillets of one or several kinds of wood and laid according to a pattern. Mosaic parquetry is mostly premanufactured in the form of parquetry elements but it may also be composed of single pieces.

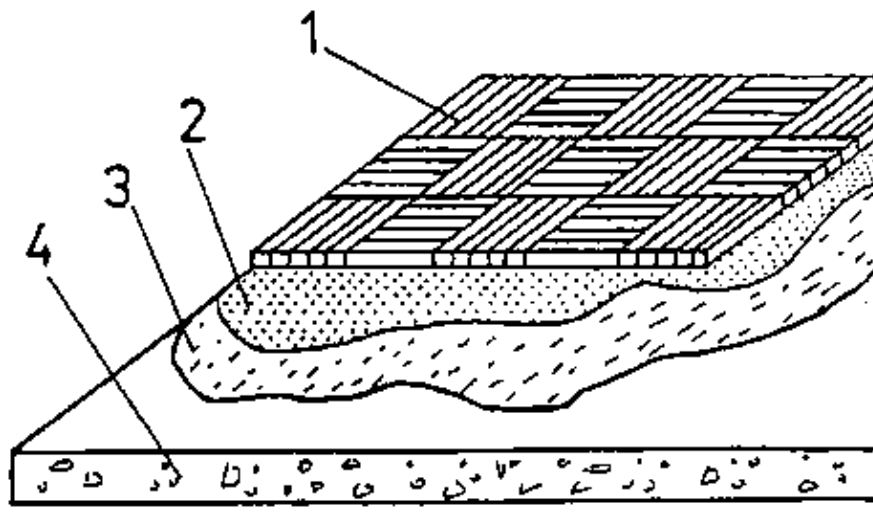

Figure 6

Mosaic fillet parquetry

1 mosaic fillet, 2 adhesive, 3 pre-coating, 4 solid subfloor

What types of parquetry are there?

The kinds of wood used for the above mentioned parts of parquetry must be hard, must have no knots or off-colours, no 'bark bags', no infestation, only very few capillary cracks and absolutely no working faults.

Parquetry is the aesthetically most effective flooring. Therefore, great importance has to be attached to its design.

This depends mainly on the size of the room as well as on its future use.

This holds good for the size of the individual parts of parquetry as well as for its design.

Kinds of parquetry patterns in use are:

Herring-bone pattern

The laying is very complicated and time-consuming. A frieze strip must be laid along the edges for calming.

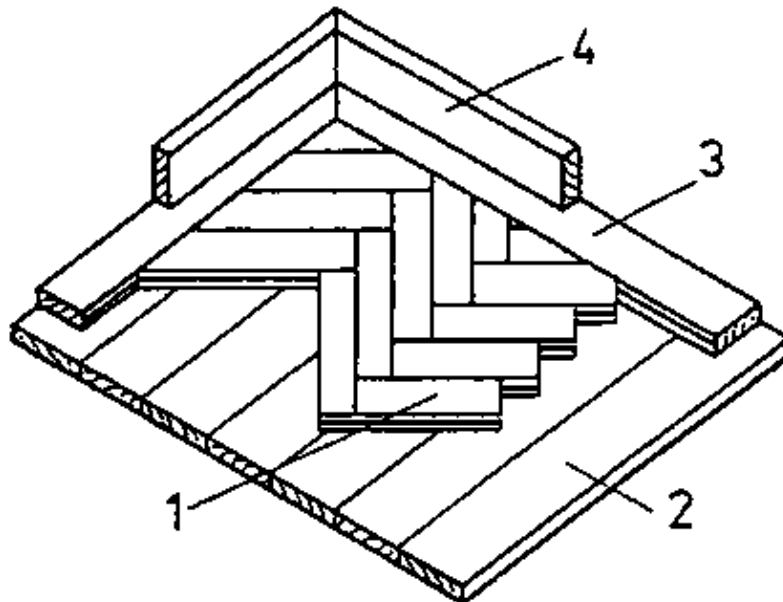

Figure 7

Parquetry – herring-bone pattern

1 parquetry-fillet, 2 planed boarding, 3 frieze strip, 4 skirting board

Belt or ship's bottom pattern

Laying is easier. The pattern can be continued right to under the skirting board.

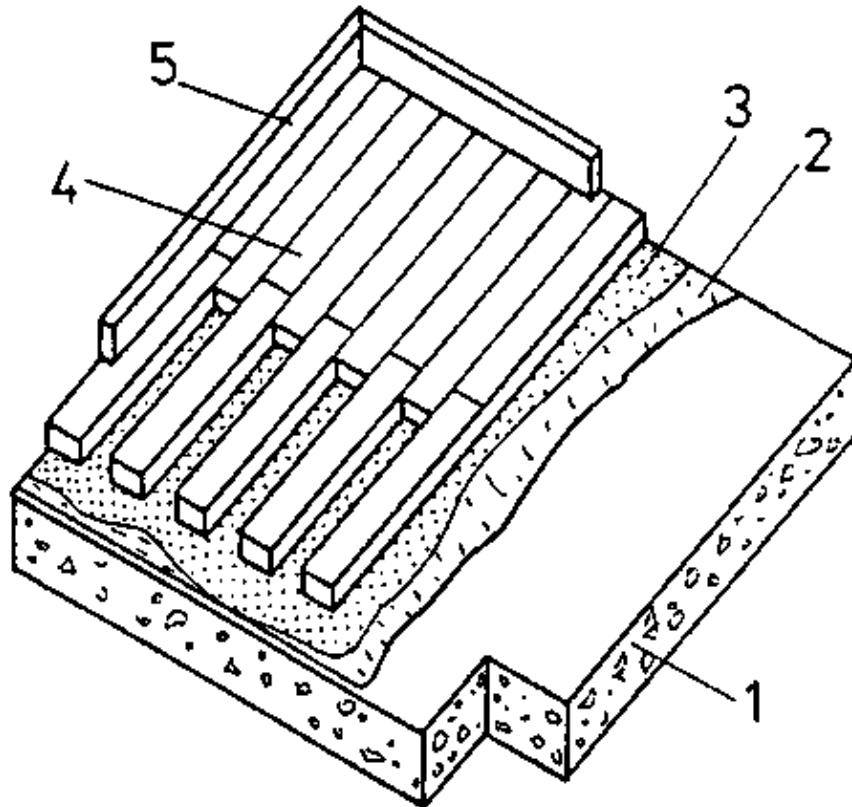

Figure 8

Parquetry – belt or ship’s bottom pattern

1 solid subfloor, 2 precoat/adhesive, 3 bituminous felt/adhesive, 4 parquets–fillets, 5 skirting board

For the top layers of parquetry elements mainly mosaic pattern and combined forms – mosaic fillets and wood panels – are used.

The following should be considered with the organization of a parquet–covered surface:

- The entire surface must keep its uniform appearance.
- Accentuations in one direction may cause optical illusions. They should therefore be applied carefully.
- Illusory spatial effects as caused by certain arrangements of shapes and distribution of brightness have to be avoided.
- Individual forms organizing the surface must be in harmonic correspondence with the size of the total surface.

Belt or ship’s bottom pattern appears as balanced due to its uniform surface, though it is animated by the structure of the wood.

With the herring–bone pattern the direction and counter–direction of the individual pieces almost neutralize each other. The frieze strip running along the border creates a harmonious transition to the skirting board and the wall surface.

4. Advice for and Rules with Making Parquet Floors

4.1. Preparation of the Subfloor

Subfloors are made in the following forms:

- Timber beam floor
- Solid floor
- Solid floor with rooms without basement

In the case of a timber beam floor, the following has to be done:

- The inherent stability of the boards is checked. If necessary, they are renailed, replaced or turned.
- The timber is checked for pest infestation and, if required, single pieces are replaced.
- If the boarding floor is no longer able to support load, the boards are taken off and replaced by a 24 mm thick layer of blind boards which are nailed on the timber beams.
- If the 'new' floor level must not be higher than the 'old' one, the boards are inserted between the timber beams and fixed to laterally screwed-on laths. No spiral-grained wood or wood with falling-off knots must be used for the laths. Wooden floors must not be covered with bituminous or tar-saturated felt. The parquet layer can be nailed on the prepared surface.

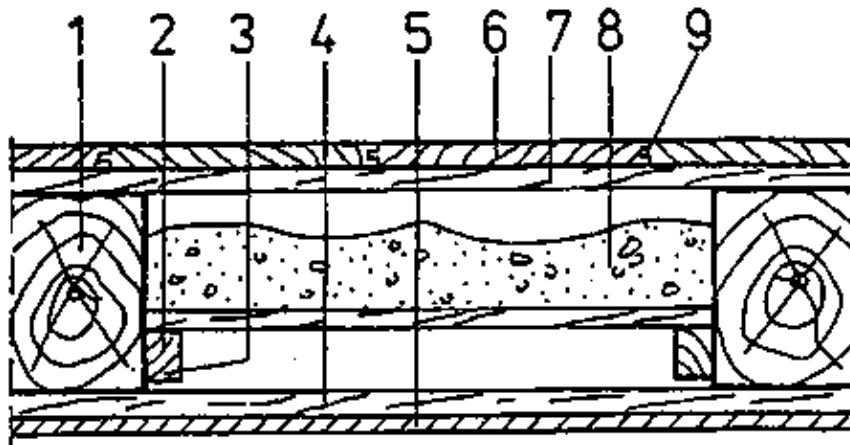

Figure 9

Parquetry elements on planed boarding

1 floor beam, 2 inserted timber, 3 laths, 4 timbering, 5 lathwork/plaster, 6 parquet deals, 7 planed boarding, 8 filler, 9 tongue

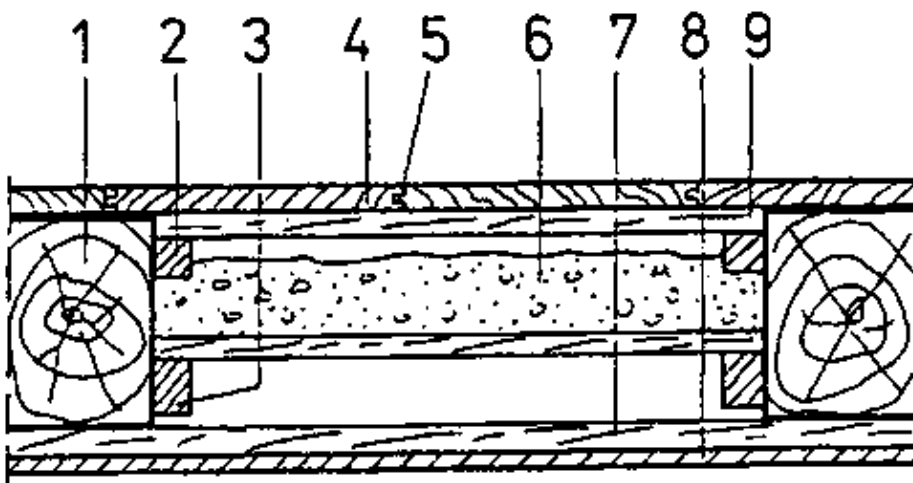

Figure 10

Parquetry elements on planed boarding laid on a lower level between the beams

1 beam, 2 supporting laths, 3 laths, 4 parquet deals, 5 tongue, 6 filler, 7 timbering, 8 lathwork/plaster, 9 planed boarding fitted between the beams

With solid ceilings and solid floors, respectively, the following sequence of operations is to be adhered to:

- Shall the parquetry be laid on a solid floor, make sure that there is a proper thermally insulating and moisture-proofing layer. If required, it has to be supplied additionally.
- First of all, the solid ceiling or floor, respectively, is carefully cleaned. In doing so, all loose parts are removed.
- The solid ceiling or floor must not release any sand or show any kind of greater unevennesses in its surface. Possibly it must be repaired or reworked.
- When using parquetry-fillets and/or parquetry elements, a layer of bare bituminous felt, pasted edge to edge, must be laid under the parquetry.
Attention! – not with mosaic parquetry!
- Another technique is the laying of supporting beams, if height is no problem. These supporting beams can be covered with a false floor.

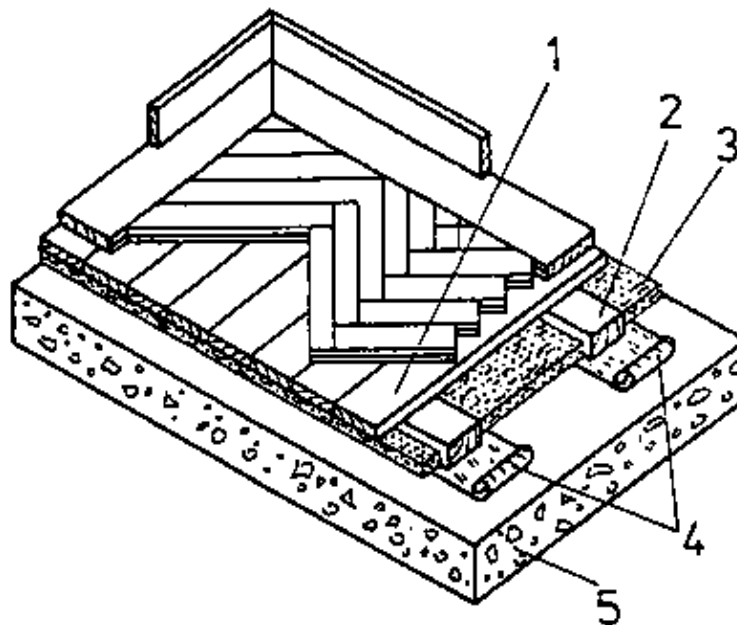

Figure 11

Parquetry-fillets with false floor and beam layer on solid subfloor

1 false floor, 2 beam layer, 3 insulating material, 4 bituminous felt strips, 5 solid substructure

In this case, an essential improvement in thermal insulation and sound proofing can be achieved. With this kind of subfloor, parquetry is nailed.

What kinds of subfloors are in use?

When is tar-saturated or bituminous felt laid as the immediate base of parquetry?

How can the insulation properties of a solid floor be improved in connection with parquet laying?

4.2. Laying of Parquet

Parquet can be nailed or pasted.

Fillets of mosaic parquetry are always pasted due to their small dimensions.

The most commonly used dimensions of mosaic parquetry–fillets, as well as parquetry–fillets are given in the below survey:

Survey 1: Current dimensions of mosaic parquetry–fillets and parquetry–fillets

Mosaic parquetry–fillets

	Thickness	Width	Length
Tolerances (mm)	± 0.3	–	± 0.1
Dimensions (mm)	8	20...	120
		27	130
			150
			160

Parquetry–fillets

	Thickness	Width	Length	
Tolerances (mm)	± 0.4	± 0.5 %	± 0.2	
			Short fillet	Long fillet
Dimensions (mm)	16,18	40,50	200	600
	20,22	60,70	250	700
		80,90	300	800
		100	350	1000
			400	
			450	
			500	

Adhesive for laying parquetry

This is a bituminous solution or other suitable product which is typical of the respective country. Its properties must be elastic and plastic ones. As pre-coating, diluted adhesive is used.

Nails for laying parquetry

For this purpose, the below mentioned nails are to be used preferably:

- With 22 mm thick parquet floor – 45 mm or 50 mm long countersunk head nails.
- With thinner parquet floor – 40 mm long countersunk head nails.
- With parquet elements – 50 mm long countersunk head nails.

Before parquetry is laid, all the other constructional and interior work must be completed.

The room temperature with parquet laying must be at least 15 centigrade, and the relative air humidity must be between 45 and 65 %.

Laying of parquetry–fillets on wooden floors

After the careful cleaning of the wooden subfloor, the parquetry–fillets are laid – not parallel to the longitudinal direction of the boards of the false floor or of the deals. The parquetry–fillets are fixed by covered nailing through the narrow surface. With 200 – 400 mm long fillets use one nail, and with 400 – 500 mm long fillets use two nails. Connections with other kinds of floor covering are made with the help of metal strips as splicing pieces.

Laying parquetry–fillets on solid subfloors

After careful cleaning parquetry adhesive is spread with a drawing scraper over the entire surface of the subfloor.

On this a layer of bare bituminous felt – butt–joined – is pasted – not with mosaic parquetry.

On this layer parquetry adhesive is spread in such way that the parquetry–fillets lie in the bed of adhesive by at least 2/3 of their base surfaces.

With parquetry–fillets designed for loose keys the cross–grain keys have to be distributed evenly over at least 50 % of the entire length of the slots.

Laying of parquetry–fillets on supporting beams with or without false floor

The process is the same as with laying parquetry–fillets on wooden floors, vis. Fig. 11.

Laying of mosaic parquet

After careful cleaning of the solid subfloor a precoating of thinned adhesive is made.

Then the parquet adhesive is spread over the subfloor and the mosaic parquet is pressed firmly into the adhesive film.

How can parquetry be connected with the surface under it?

How must parquetry–fillets be nailed on?

4.3. Dressing

After the parquetry has been laid and the adhesive has aged, which takes at least two days, the floor is mechanically ground and sealed three times afterwards. After each sealing a technical waiting time of 24 hours has to be kept.

Sealers:

The sealer fills the pores of the floor, forms a well–adherent and wear–resistant film which protects the parquet against wear and moisture.

- The following sealers are used for parquet floors:
- Oil and synthetic resin sealers
- Acid–hardening sealers
- Sealers consisting of several components

- Polyurethane sealers
- Epoxide resin sealers

– Combination cellulose nitrate sealers

The sealers show various properties. Therefore, their specific use depends on the future purpose. Greatest hardness is achieved by multicomponent sealers.

Parquetry work has to be integrated in the entire building process in such way that no bricklaying or installation work must be done after the parquetry has been laid.

As a rule, parquetry should be laid even after painting.

How long is the technological waiting period after sealing?

Why should parquetry be laid always at the end of all building work?

What kinds of sealers are there?

Which sealers give the greatest hardness?

How is parquetry finished?

Partition Wall Making – Course: Timberwork techniques. Instruction examples for practical vocational training

Table of Contents

<u>Partition Wall Making – Course: Timberwork techniques. Instruction examples for practical vocational training</u>	1
<u>Preliminary Remarks</u>	1
<u>Instruction Example 5.1.: Calculation of the Pitch Size</u>	4
<u>Instruction Example 5.2.: Scribing of the Runners</u>	6
<u>Instruction Example 5.3.: Scribing of the Posts</u>	11
<u>Instruction Example 5.4.: Scribing of the Stiffening Transoms</u>	16
<u>Instruction Example 5.5.: Scribing of the Door Framework</u>	20
<u>Instruction Example 5.6.: Assembly and Erection of the Partition Wall</u>	22

Partition Wall Making – Course: Timberwork techniques. Instruction examples for practical vocational training

Institut für berufliche Entwicklung e.V.
Berlin

Original title:
Lehrbeispiele für die berufspraktische Ausbildung
“Herstellen von Zwischenwänden”

Author: Rolf Becher

First Edition © IBE

Institut für berufliche Entwicklung e.V.
Parkstraße 21/23
13187 Berlin

Order No.: 93–33–3605/2

Preliminary Remarks

The present booklet contains 6 selected instruction examples. They have been selected so that the individual exercises can be practised separately or successively, one based on the previous one.

They all refer to the partition wall to be made which is shown in the detailed drawing on page 5 in the scale of 1: 100. The sizes in the detailed drawing have been freely selected to provide feasible sequences of operations in the instruction examples.

The room limitation in the detailed drawing indicates that a corner post will be required for the partition wall to be made and that the new room has to be made accessible.

The partition wall is to be built between wooden beam ceilings with wall (1) at right angles and wall (2) parallel to the straining direction of the wooden beams.

The instruction examples include the sequence of operations and necessary comments. For instruction examples 2. to 5., working drawings are attached. The individual instruction examples also include information as to the required hand tools, measuring and testing means, auxiliary accessories and the necessary previous knowledge.

Layout of the building with partition wall to be made (scale 1:100)

Instruction Example 5.1.: Calculation of the Pitch Size

The pitch sizes for the partition wall shown in the detailed drawing are to be determined.

Known:

Room height: 2500 mm

Length of surface covering material: 2500 mm

$a_{adm} = 600$ mm

The runners are cut from 50 mm thick and 4000 mm long boards

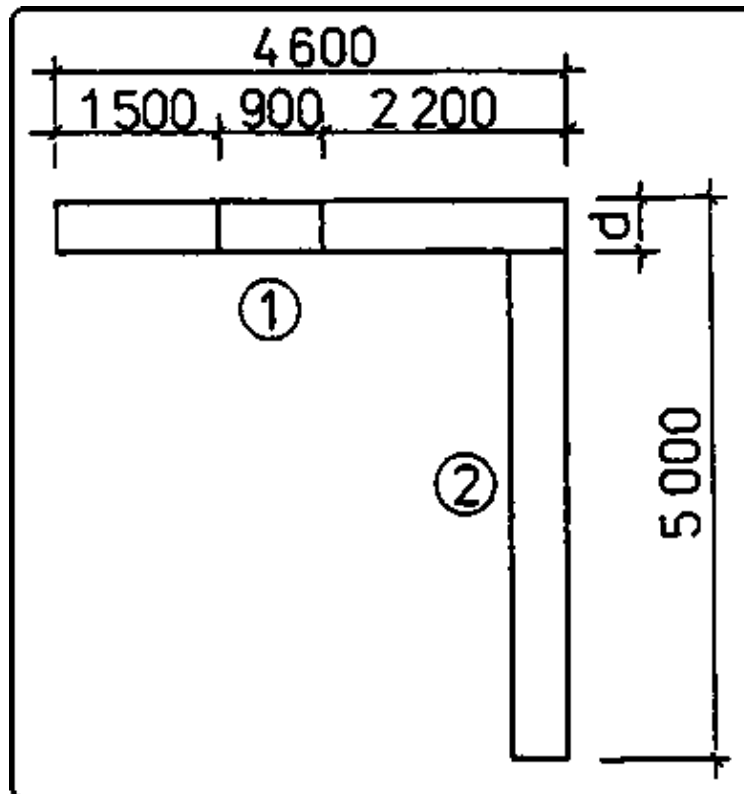

Hand tools

None

Measuring and testing means

None

Auxiliary accessories

Paper for calculations, pencil, possibly calculator

Necessary previous knowledge

Fundamental operations, reading of drawings

Sequence of operations	Comments
1. Determine the cross section of timbers for the posts.	<ul style="list-style-type: none"> - Read cross section in table 1. - Select: $b = 60$ mm, $d = 75$ mm.

	<ul style="list-style-type: none"> – Use squared timbers of 60/80 mm². – d for the runner thickness = 80 mm – b for the post width = 60 mm
2. Calculate the pitch size for wall (1).	
$a_1 = a = \frac{L_t - \frac{b}{2}}{n_{Fa}}$ Requ.:	
$L_t = \frac{G1}{n_{Ta}}$ Known:	(2) $L_t = \frac{4600\text{mm}}{2}$
b = 60 mm	Lt = 2300 mm
$n_{Fa} = \frac{L_t - \frac{b}{2}}{a_{adm}}$	(3) $n_F = \frac{2300\text{mm} - \frac{60\text{mm}}{2}}{600\text{mm}} = 3.7$
G1 = 4600 mm	$n_{Fa} = 4$
$n_{Ta} = \frac{G1}{M1}$	$n_{Ta} = \frac{4600\text{mm}}{2500\text{mm}} = 1.8$
a _{adm} = 600 mm	n _{Ta} = 2
M1 = 2500 mm	(4) $a_1 = \frac{2300\text{mm} - \frac{60\text{mm}}{2}}{4}$
	$a_1 = 567.5 \text{ mm}$
	() indicates the steps of calculation.
3. Calculate the pitch size for wall (2)	<ul style="list-style-type: none"> – Since the partition walls meet at right angles, G1 for wall (2) is not 5000 mm! The thickness d = 80 mm (runner thickness) is to be subtracted from G1 = 5000 mm!
$a_2 = a = \frac{L_t - \frac{b}{2}}{n_{Fa}}$ Requ.:	
$L_t = \frac{G1}{n_{Ta}}$ Known:	– Follow steps of solution exactly!
b = 60 mm	
$n_{Fa} = \frac{L_t - \frac{b}{2}}{a_{adm}}$	
G1 = 5000 mm – d	

$n_{Ta} = \frac{G1}{M1}$	
$a_{adm} = 600 \text{ mm}$	
$d = 80 \text{ mm}$	(1) $G1 = 5000 \text{ mm} - 80 \text{ mm}$
$M1 = 2500 \text{ mm}$	$G1 = 4920 \text{ mm}$
	(2) $n_T = \frac{4920\text{mm}}{2500\text{mm}} = 1.9$
	$n_{Ta} = 2$
	(3) $Lt = \frac{4920\text{mm}}{2} = 2460\text{mm}$
	(4) $n_F = \frac{2460\text{mm} - \frac{60\text{mm}}{2}}{600\text{mm}} = 4.05!$
	$n_{Fa} = 5!$
	(5) $a_2 = \frac{2460\text{mm} - \frac{60\text{mm}}{2}}{5}$
	$a_2 = 486 \text{ mm}$

Instruction Example 5.2.: Scribing of the Runners

The foot and head runners for the partition wall shown in the detailed drawing are to be scribed.

Known:

Runner thickness: 80 mm

Runner height: 50 mm

Post width: 50 mm

Joint post width: 80 mm

Door size: 900/200 mm²

Pitch size for

wall (1) = 567.5 mm

wall (2) = 468 mm

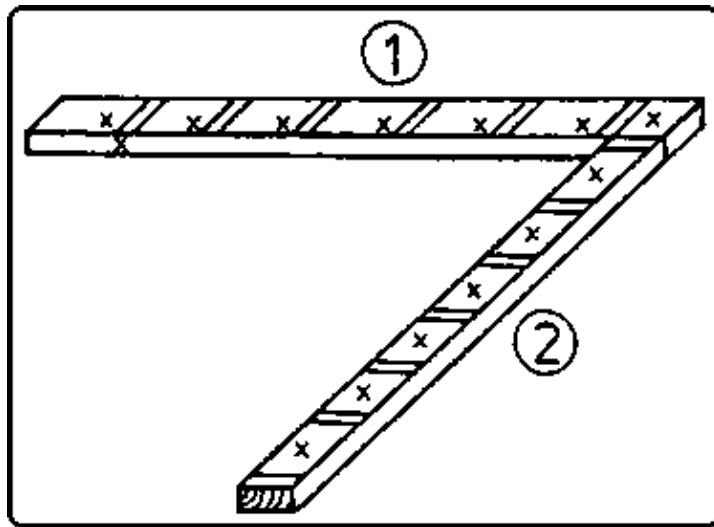

Hand tools

Hammer

Measuring and testing means

Folding rule, carpenter's square

Auxiliary accessories

Pencil, template for post width, marking gauge, abrasive paper, one-ell trestles

Necessary previous knowledge

Reading of drawings, scribing, measuring, angling

Remarks to the working drawing

A head, B foot

Sequence of operations	Comments
1. Decide on the joining side of the runners.	
2. Put runners for wall (2) on the trestles.	<ul style="list-style-type: none"> - Mind position of joining side. (See Fig. 18 in Trainees' Handbook of lessons.) - Put runners closely together. - Put runners about flush at left ends. - Select distance of trestles so that runners cannot tilt up when scribing.
3. Scribe shortening at left ends of runners and mark with section mark.	<ul style="list-style-type: none"> - Go to the right only as far as necessary to produce a right-angle section. - Place long leg of square at the longitudinal side of the runner at the front. Scribe a thin line only.
4. Measure-in the pitch size.	<ul style="list-style-type: none"> - Mark only at the front edge of the runner at the front. - Measure cumulatively. - Check the total length. (If markings do not fit into total length, find measuring error and make correction!) - Remove or delete wrong markings.

5. Scribe pitch size and mark with jointing mark.	<ul style="list-style-type: none"> – Use the square. – Make sure that the square is placed correctly. – Mark with jointing mark at the correct side of scribed line! (work from jointing)
6. Scribe the post width.	<ul style="list-style-type: none"> – Use a template (piece of board having the exact width of the post). – Scribe from jointing!
7. Measuring–in the posts for the door, scribe and mark with “T”.	<ul style="list-style-type: none"> – The sizes given in the detailed drawing are all finished sizes! – The clear size for the door opening is to be scribed bigger at both sides because the door reveal will be provided with panelling (lining)!
8. Measure–in and scribe the additional post.	<ul style="list-style-type: none"> – Measure the thickness of the surface material for the wall covering plus post width from the foot runner of wall (2) to the left!
9. Scribe the mortise width.	<ul style="list-style-type: none"> – Use a marking gauge. – Scribe from the joining side of the runners!
10. Scribe the corner tenons.	<ul style="list-style-type: none"> – Corner tenons are to be provided at <ul style="list-style-type: none"> • wall posts, • corner posts, • door post, • door fixing post.
11. Delete scribed post lines on the foot runner which are not needed.	<ul style="list-style-type: none"> – Posts in the area of the door opening. – Delete with wavy line or abrase by means of abrasive paper.
12. Put runner for wall (2) on the trestles and scribe.	<ul style="list-style-type: none"> – Repeat steps 2., 3., 4., 5., 6., 9. and 10. accordingly! If door openings are required in a partition wall to be built, the mortises are to be numbered on the head runner starting from the left. The numbers are to be marked on the side opposite the jointing mark.

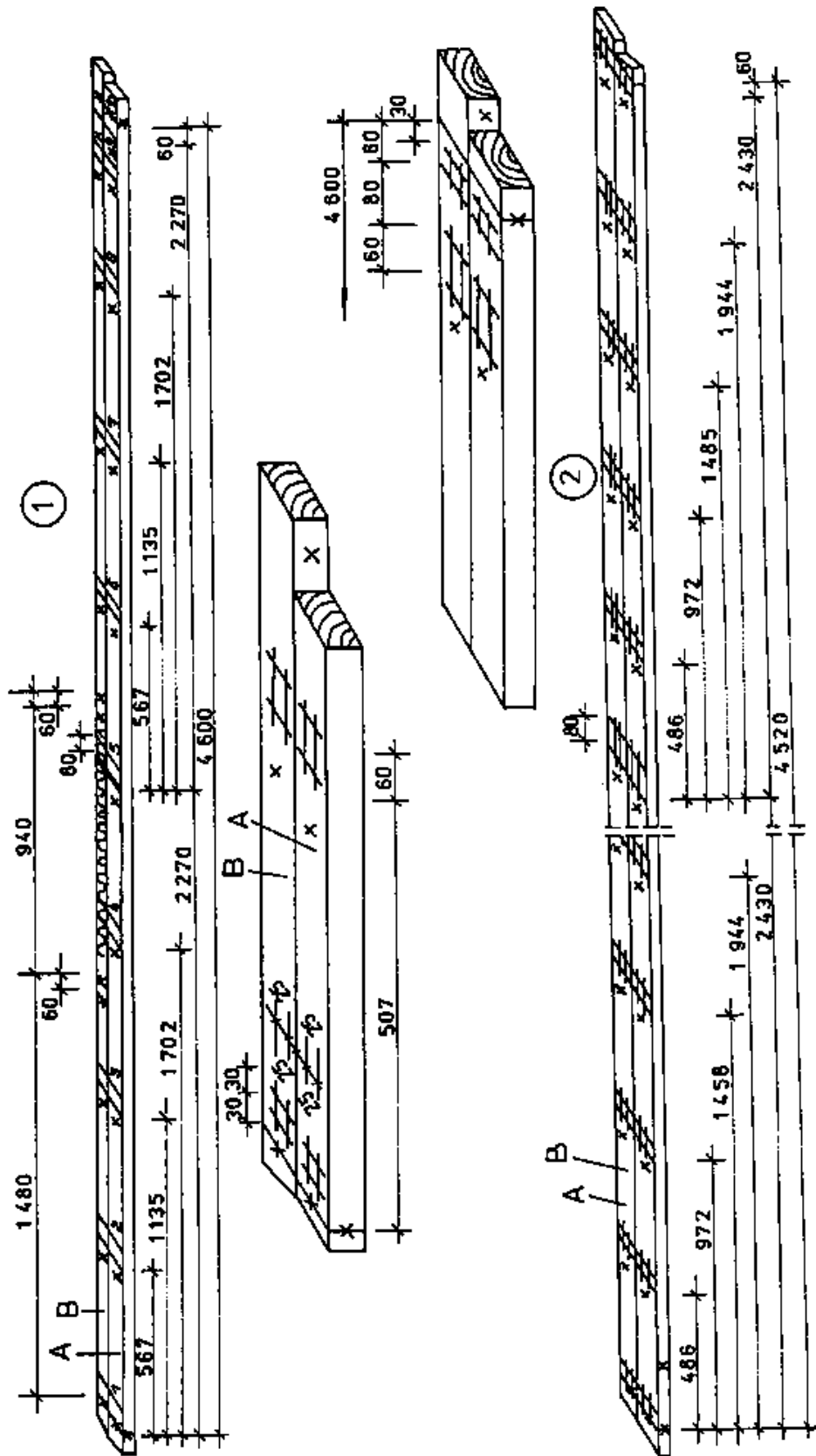

			5.2.
IBE	Scribing of the foot and head runners		10 3605

Instruction Example 5.3.: Scribing of the Posts

The posts for the partition wall shown in the detailed drawing are to be scribed.

Known:

Joint post: $b = 80 \text{ mm}$, $d = 80 \text{ mm}$

Posts: $b = 60 \text{ mm}$, $d = 80 \text{ mm}$

Stiffening transoms: $b = 50 \text{ mm}$, $d = 80 \text{ mm}$

Runner height = 50 mm

Room height = 2500 mm

The number of the posts is taken from the foot runners.

Wall (1): 10 posts

Wall (2): 10 posts

1 joint post

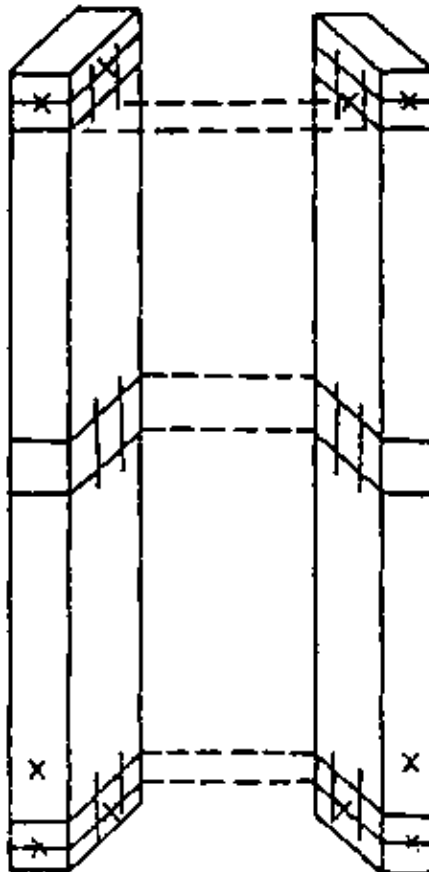

Hand tools

Hammer

Measuring and testing means

Folding rule, carpenter's square

Auxiliary accessories

Pencil, marking gauge, abrasive paper, one–ell trestless

Necessary previous knowledge

Reading of drawings, measuring, angling, scribing

Remarks: The joint tail post in wall (1) is dealt with in Instruction Example 5.5.!

Sequence of operations	Comments
1. Decide on the joining side of the posts and mark it.	
2. Put the posts on the trestles.	<ul style="list-style-type: none"> – Do not put on more than 5 posts. – Place the posts with the joining side on top. – Put the posts closely together and about flush at the left ends. – Include joint post, door post and corner post.
3. Scribe shortening at left ends of the posts and mark with section mark.	<ul style="list-style-type: none"> – Go to the right only as far as necessary to produce a right–angle section.
4. Measure–in and mark the tenon length, measure–in and mark the lower edge of stiffening transom, measure–in and mark the upper edge of stiffening transom, measure–in and mark the tenon length.	<ul style="list-style-type: none"> – Measure cumulatively! (20 – 1195 – 1245 – 2420 – 2440 mm). – Check the two outer markings with the total length. – Total length: room height minus two runner heights plus two tenon lengths (2500 – 2 • 50 + 2 • 20) mm = 2440 mm. – If the sizes (total length and the two outer marking) do not correspond, find the measuring error and make correction. – Abrase wrong markings to avoid scribing errors!
5. Scribe all markings over the posts put on the trestles.	<ul style="list-style-type: none"> – Scribe thin lines. – Place long leg of carpenter’s square at the post put at the front. – Mark the sections at both ends.
6. Check the scribed lines.	<ul style="list-style-type: none"> – Place the post from the front at the post at the rear and check the scribed lines.
7. Scribe the tenon parapets.	<ul style="list-style-type: none"> – Move the posts apart so that the marking gauge can be used for scribing without hindrance. – Scribe from the joining side. – Do not cant the marking gauge. – Scribe at the left ends of the posts all front parapets (at jointing) first, then all rear parapets and then scribe all parapets at the right ends.
8. Scribe the stiffening	<ul style="list-style-type: none"> – Angle at both sides the scribed lines for stiffening transoms on posts. – Put long leg of square on joining side. – Scribe thin lines.
9. Scribe the mortises for stiffenings transoms.	<ul style="list-style-type: none"> – Use marking gauge. – Scribe from the joining side. – First scribe all front parapets at both sides, then all rear parapets at both sides. – Do not cant the marking gauge.

10. Scribe the corner tenons.	<ul style="list-style-type: none"> – Scribe only wall posts and corner posts. – Mind the joining side and, in particular, mirror image of corner tenons.
11. Remove the scribed posts from the trestles and put on the next ones for scribing.	<ul style="list-style-type: none"> – Do <u>not</u> take off the post at the front! – It is used as template for the posts to be scribed. – Do not exceed the maximum number to be put on. – Joining side to be on top! – Put the posts closely together and about flush at the left ends.
12. Scribe the posts.	<ul style="list-style-type: none"> – Place the scribed post (template) and transfer all scribed lines onto the posts put on the trestles. – Place exactly. – Check the scribed lines. – Repeat steps 7., 8. and 9. above, accordingly. <p>If more posts are required, steps 11. and 12. above are to be repeated always using the same post as template.</p>
13. Number the posts for wall (1).	<ul style="list-style-type: none"> – Take numbering from head runner. – Number at lower end of posts. – Start numbering from the left. – Mind right-hand corner post (to be provided with last number). – While the door posts have been scribed, they are not to be numbered.

Instruction Example 5.4.: Scribing of the Stiffening Transoms

The stiffening transoms for the partition wall shown in the detailed drawing are to be scribed.

Known:

- One transom in the wall at half height of room.
- Transom timber height: 50 mm
- Transom timber thickness: 80 mm
- Transom timber length: 5000 mm

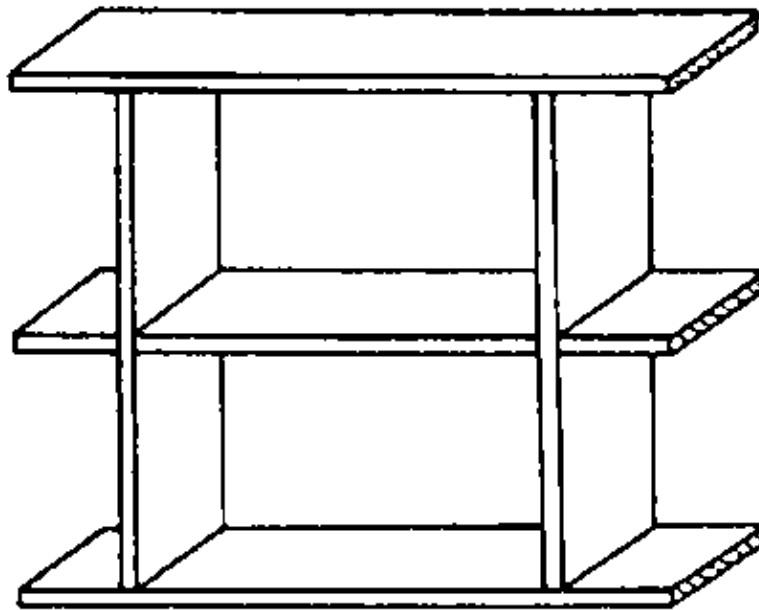

Hand tools

Hammer

Measuring and testing means

Folding rule, carpenter's square

Auxiliary accessories

Pencil, marking gauge, abrasive paper, one-ell trestles

Necessary previous knowledge

Reading of drawings, measuring, angling, scribing

Sequence of operations	Comments
1. Put transom timber and foot runner for wall (1) on the trestles.	– Put the two timbers closely together and about flush at the left ends.
2. Scribe the stiffening transom lengths.	– Use the foot runner as template. – Place the long leg of carpenter's square at foot runner and transfer all scribed lines (except for section lines) onto transom timber.

	<ul style="list-style-type: none"> – Include door posts. – Provide each scribed stiffening transom with jointing mark at the transom height.
3. Measure–in and scribe the tenon length.	<ul style="list-style-type: none"> – Start at the right scribed line of the left corner post and measure–in and scribe to the left. – Mark the scribed line with section mark. – On the second to eighth post, scribe from the left scribed line to the right and from the right scribed line to the left and mark with section mark. – Do not scribe tenon length between the door posts.
4. Scribe the tenon parapets.	<ul style="list-style-type: none"> – Remove the foot runner to provide freedom to move for scribing. – Start from the joining side, scribe all front parapets and then all rear parapets. Use marking gauge and do not cant it when scribing.
5. Angle at the sides and scribe the necessary lines.	<ul style="list-style-type: none"> – Put long leg of square on the transom timber and scribe downwards at both sides. – Mark the section lines.
6. Put the transom timber and foot runner for wall (2) on the trestles.	<ul style="list-style-type: none"> – Proceed as with step 1. above.
7. Scribe the stiffening transom.	<ul style="list-style-type: none"> – Repeat steps 2., 3., 4. and 5. above, accordingly.

Instruction Example 5.5.: Scribing of the Door Framework

The door framework for the partition wall (1) is to be scribed.

Known:

- Door height: 2000 mm
- Door width: 900 mm
- Door posts are already scribed.
- Door lintel transom size

$$d = 80 \text{ mm}, h = 50 \text{ mm}, l = 1800 \text{ mm}$$

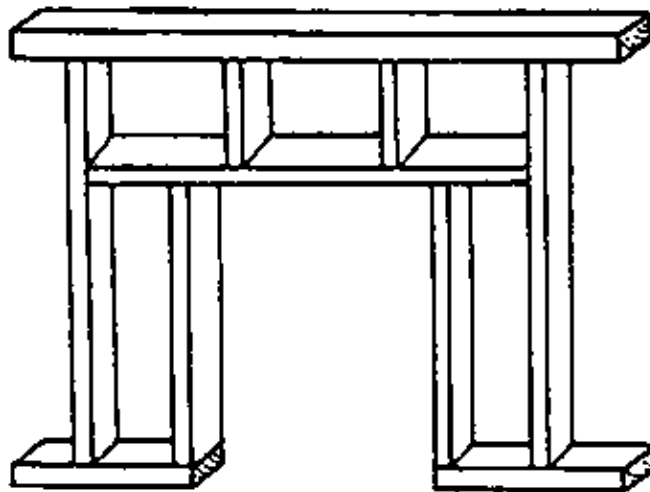

Hand tools

Hammer

Measuring and testing means

Folding rule, carpenter's square

Auxiliary accessories

Pencil, marking gauge, abrasive paper, one-ell trestles

Necessary previous knowledge

Measuring, angling, scribing, reading of drawings

Sequence of operations	Comments
1. Put posts 3 and 6, as well as door posts "4" and "5" on the trestles.	– Place the scribed lines flush. – Jointing marks to be at the left and on top. – Sequence is important! Start at front: Post 3 door post "4" door post "5" post 6.

2. Measure—in position of door lintel transom, scribe and mark.	<ul style="list-style-type: none"> – Measure from surface of floor. Scribing size: clear door height minus foot runner plus 20 mm allowance for jamb lining (2000 mm – 50 mm + 20 mm = <u>1970 mm</u>) – Measure—in the size on the post at the front, place the square and scribe.
3. Take out the door posts and move posts 3 and 6 closely together.	<ul style="list-style-type: none"> – Leave the door posts on the trestles. – Do not change the jointing marks. – Put the scribed lines of posts 3 and 6 flush. – Post 3 to remain at the front!
4. Measure—in and scribe the lintel transom height.	<ul style="list-style-type: none"> – Use the square.
5. Scribe the mortises.	<ul style="list-style-type: none"> – Scribe from the joining side. – Scribe only on the front side of post 3 and onto the rear side of post 6. – Use the marking gauge; do not cant it.
6. Scribe and mark the tenon length on the door posts.	<ul style="list-style-type: none"> – Measure and scribe from the scribed door lintel transom line towards the head runner. – Mark the scribed line with section mark.
7. Scribe the tenon parapets.	<ul style="list-style-type: none"> – Scribe the front and rear parapets from the joining side. – Delete or abrase the scribed mortise lines for the stiffening transoms on the side opposite the corner tenon.
8. Put the door lintel transom on the trestles and mark with jointing mark.	<ul style="list-style-type: none"> – Scribe the joining side at door lintel transom height
9. Scribe the shortening and mark with section mark.	<ul style="list-style-type: none"> – Go only as far as necessary to produce a right–angle section.
10. Measure—in and scribe the tenon length and door lintel transom length.	<ul style="list-style-type: none"> – Measure—in and scribe the tenon length at the left end. – Measure—in and scribe the door lintel transom lengths (Take the length from the head runner! Clear size between the posts 3 and 6). – Measure—in the tenon length at the right end, scribe and mark with section mark.
11. Scribe the tenon parapets.	<ul style="list-style-type: none"> – Scribe the front and rear parapets from the joining side.
12. Scribe the mortises for the tail posts.	<ul style="list-style-type: none"> – Scribe on the top face of the door lintel transom!!! – Take the sizes from the head runner. (Place batten to contact post 3 and transfer scribed lines onto batten). – Scribe tenon parapet and mortise width from the joining side. – Use the marking gauge and do not cant it.
13. Scribe the mortises for the door posts.	<ul style="list-style-type: none"> – Scribe on the bottom face of the door lintel transom! – Take the sizes from the foot runner. (Place batten to contact post 3 and transfer scribed lines onto batten). – Scribe the tenon parapet and mortise width from the joining side. – Use the marking gauge.
14. Scribe the tail posts.	<ul style="list-style-type: none"> – Use the sections of the door posts. – Take the size from post 3 and transfer it to the tail post. – For the joint tail post, a cover strap of 20 mm thickness is to be nailed on the erected partition wall at the side of the joint tail post opposite the jointing mark.

			5.5.
IBE	Scribing of the door framework		3605

Scribing of the door framework

Instruction Example 5.6.: Assembly and Erection of the Partition Wall

The partition wall shown in the detailed drawing shall be built-in.

It is assumed that:

- all structural components have been provided with the necessary wood joints,
- all structural components have been made available in the existing room, where the partition wall is to be built in, in assorted stacks.

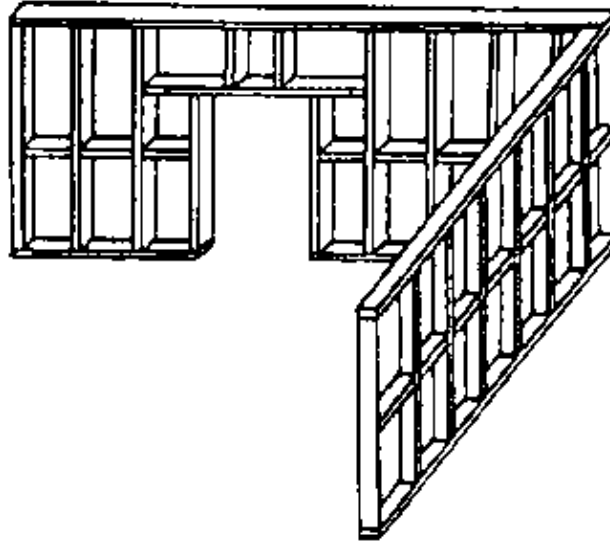

Hand tools

Hammer, hand saw, firmer chisel

Measuring and testing means

Folding rule, carpenter's square, water-level

Auxiliary accessories

Pencil, 3.4/80 nails, wooden wedges, cover strap 80 mm wide, 20 mm thick and 450 mm long, scaffolding material (two one-ell trestles, scaffolding boards 200 mm wide, 4000 mm long, 5 pcs.), cleats, drawing

Necessary previous knowledge

Aligning of timberwork

Sequence of operations	Comments
1. Scribe alignment lines on the floor.	<ul style="list-style-type: none"> – Lay out the foot runners. – Mind the joining side of runner (1) (door size is fixed). – Read the sizes for the position of the walls in the drawing and set the runners accordingly. – Scribe along the runners at the joining side and provide scribed lines with mark (bird's-mouth). – Decide on the wall to be erected first based on how the foot runners meet and on the existing building clearance (see drawing)!
2. Put the foot runner (1) on the floor near the scribed line.	<ul style="list-style-type: none"> – Think of door size! – In this example the joining side lies on the floor.
3. Mount wall post in foot runner.	<ul style="list-style-type: none"> – Pay attention to joining side and jointing mark of post. – Plug tenon into mortise and, if necessary, hammer in gently. – When hammering put cleat on tenon parapet. – Do not forcefully hammer the post into the mortise to avoid splitting of the wood! – If tenon does not fit in spite of gentle hammering, re-work tenon or mortise by means of firmer chisel.
4. Mount stiffening transom in wall post.	<ul style="list-style-type: none"> – Pay attention to the joining side. – See comments on step 3 above!
5. Mount post 2 in foot runner.	

	<ul style="list-style-type: none"> – Plug tenon of stiffening transom into mortise of post. – See step 3.
6. Mount stiffening transom in post 2.	
7. Mount post 3.	
8. Mount door post and door fixing post in foot runner.	
9. Mount door lintel transom.	– Pay attention to joining side!
10. Mount posts and stiffening transoms successively up to corner post.	– See comments on step 3.
11. Mount tail posts in door lintel transom.	<ul style="list-style-type: none"> – Pay attention to joining side. – Plug mortises on tenons from the left end of the runner and hammer–on the runner. – Underlay cleat when hammering. – Hammer sensitively, otherwise joints may part again. – Slightly enter all tenons into mortises successively first and then hammer–on the runner tightly.
13. Nail the tenons.	<ul style="list-style-type: none"> – Check the joint for close fit, press together again, if necessary. – Drive–in the nail in oblique but horizontal position. <p>(There must be sufficient wood at the joining side but the nail must still penetrate the tenon!)</p>
14. Erect the wall (1).	<ul style="list-style-type: none"> – Press the wall upwards at both sides. – Ensure equal pressure at the corner post and wall post! The nailed joints must not loosen again.
15. Align wall (1) to alignment line and perpendicularly.	<ul style="list-style-type: none"> – Move foot runner according to scribed marking on the floor (hammer gently, if necessary). – Joining side must be flush with scribed line on the floor. – Use water–level for perpendicular alignment.
16. Wedge the erected wall.	<ul style="list-style-type: none"> – Drive–in wooden wedges between ceiling and head runner. – Do not shorten wedges yet.
17. Put foot runner of wall (2) on the floor near the scribed line.	– Pay attention to joining side.
18. Mount the corner post.	<ul style="list-style-type: none"> – Pay attention to jointing mark. – See comments on the assembly of wall (1)!
19. Mount posts and stiffening transoms successively up to wall post.	– Pay attention to joining side and jointing mark.
20. Nail the tenons.	– Place nails in oblique position.
21. Align wall (2) to alignment line on the floor and perpendicularly.	<ul style="list-style-type: none"> – If necessary, drive wall (1) a little outwards at the corner post so that wall (2) can be driven in. Then drive wall (1) to wall (2) again.
22. Wedge the two walls between ceiling and head runner.	<ul style="list-style-type: none"> – Work from trestle scaffolding. – Slightly hammer the wedges and scribe the runner edge. – Successively loosen, saw–off and drive–in again the wedges, one after another. – For tightening, use a wooden section to be put on the cross–grained wood of the wedge. – Do not drive in the wedges forcefully. – Wedge at both sides of the head runner.

**Partition Wall Making – Course: Timberwork techniques. Trainees'
handbook of lessons**

Table of Contents

<u>Partition Wall Making – Course: Timberwork techniques. Trainees' handbook of lessons</u>	1
1. <u>Necessity of Partition Walls</u>	1
2. <u>Limitation of Rooms</u>	2
3. <u>Surface Covering</u>	6
4. <u>Framework of the Partition Wall</u>	6
5. <u>Calculation of the Pitch Size</u>	11
6. <u>Scribing of the Structural Components</u>	17
7. <u>Erection of the Partition Wall</u>	20
8. <u>Constructional Recommendations</u>	21

Partition Wall Making – Course: Timberwork techniques. Trainees' handbook of lessons

Institut für berufliche Entwicklung e.V.
Berlin

Original title:
Herstellen von Zwischenwänden

Author: Rolf Becher

First Edition © IBE

Institut für berufliche Entwicklung e.V.
Parkstraße 21/23
13187 Berlin

Order No.: 93–35–3605/2

1. Necessity of Partition Walls

Partition walls are necessary wherever big rooms shall be partitioned into smaller ones. The partitioning of rooms into smaller rooms depends on the use of the rooms. For example, the goods to be stored may dictate the size of the rooms and the necessity for partitioning of rooms.

But the use of a cold roof attic for housing purposes also necessitates partitioning of rooms. The use of rooms calls for specific constructional requirements to be met by the partition wall.

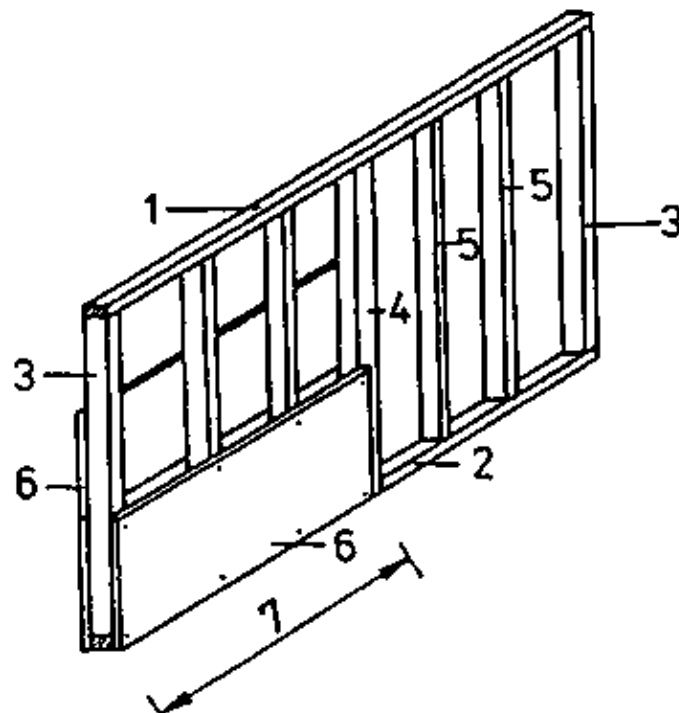

Figure 1

Partition wall without sound insulation

1 head runner, 2 foot runner, 3 wall post, 4 joint post, 5 post, 6 wall covering, 7 length of surface covering material

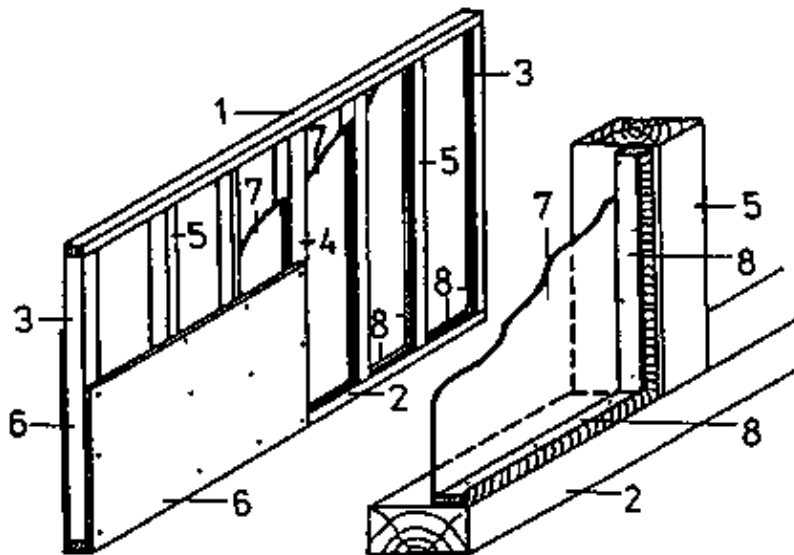

Figure 2

Partition wall with sound insulation

1 head runner, 2 foot runner, 3 wall post, 4 joint post, 5 post, 6 wall covering, 7 sound-insulating mat, 8 wooden strip

So, the design of a partition wall for housing purposes differs from that for storing purposes of temperature-insensitive or temperature-sensitive goods.

In any case, partition walls for housing purposes call for sound insulation (sound-proofing). Sometimes heat insulation will also be required. The surface finish of the partition walls also depends on the use of the room.

Rooms intended for housing purposes call for partition walls with a surface of aesthetic appearance.

This is not required when the room shall be used for storing purposes.

2. Limitation of Rooms

The partition of existing rooms and the limitation of rooms to be built by the erection of partition walls are governed by various criteria:

The rooms must be accessible.

- Existing doors are to be used.
- Existing walls can be broken through for door openings.
- Doors can also be built into partition walls.

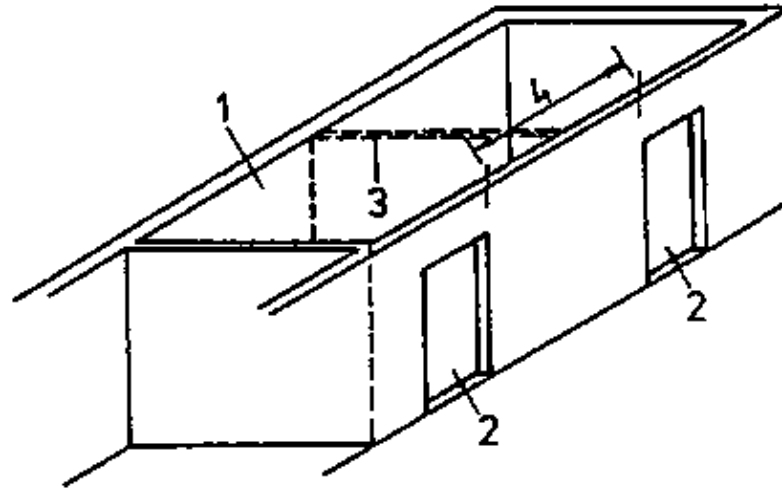

Figure 3

1 room to be partitioned, 2 existing door, 3 partition wall to be built, 4 building-in range of partition wall

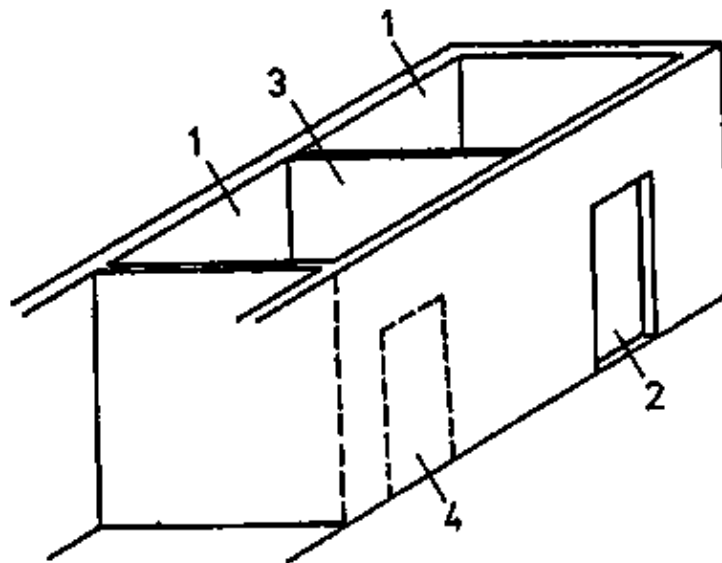

Figure 4

1 partitioned rooms, 2 existing door, 3 partition wall built in, 4 door to be made

The rooms must have ventilation facilities. Existing windows can be fixed points for partitioning of rooms.

King posts and angle braces in attics are to be taken into account for limitation of rooms. The floor space of the rooms to be built is limited by the roof structure

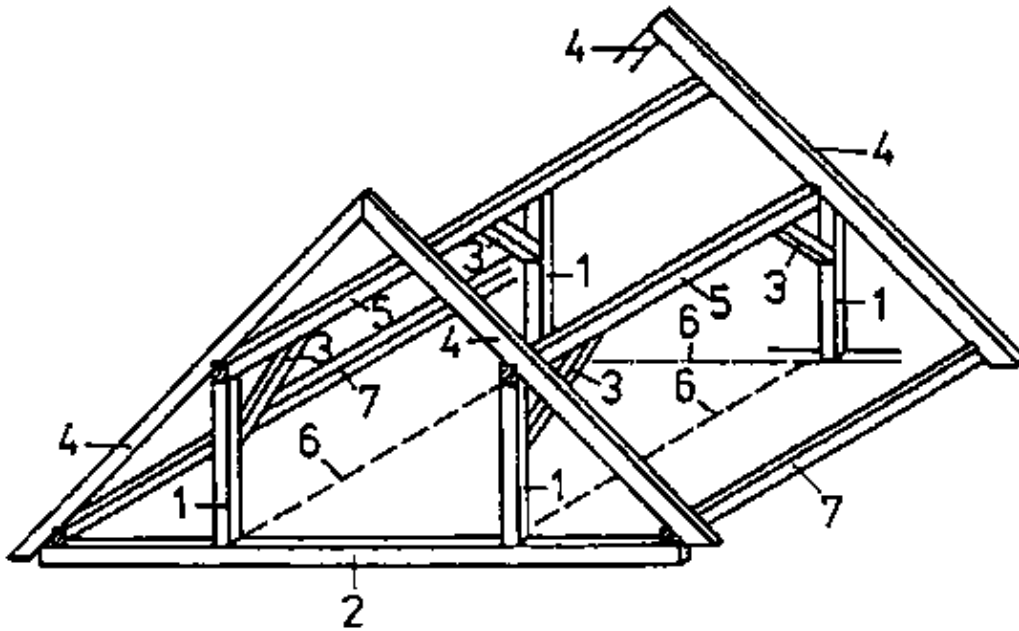

Figure 5

1 king post, 2 attic beam, 3 angle brace, 4 roof rafter, 5 trussed purlin, 6 room limitation by king posts, 7 inferior purlin

Trussed purlins in attics are fixed points for height limitation.

They limit the height of the rooms to be built.

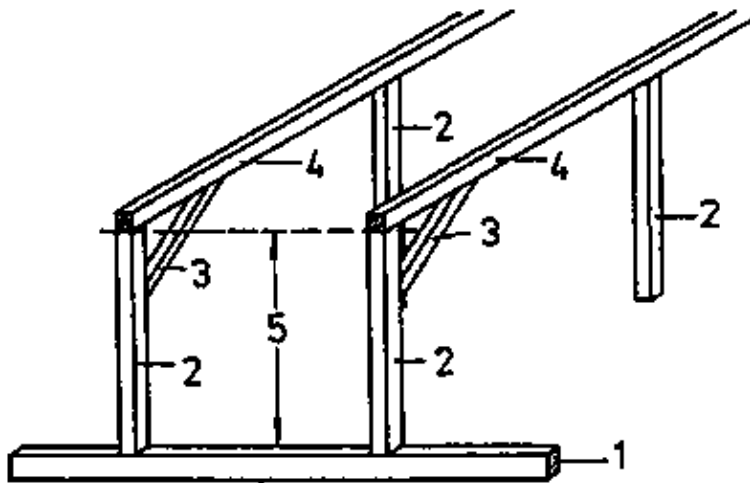

Figure 6

1 attic beam, 2 king post, 3 angle brace, 4 trussed purlin, 5 height limitation by trussed purlin

The location of the wooden beams of a wooden beam ceiling may have influence on the floor space dimensions of the rooms to be built.

The location and straining direction of wooden beams can be concluded from uncovered nailing.

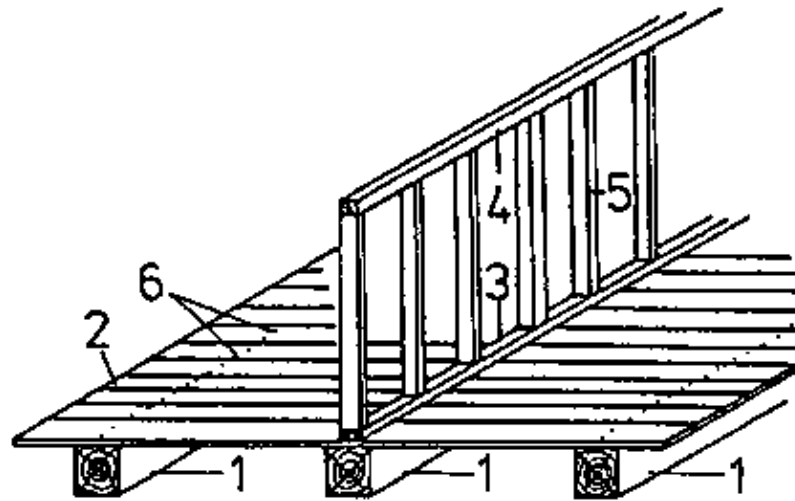

Figure 7

1 wooden beam, 2 straining direction of boarding, 3 foot runner, 4 head runner, 5 post, 6 uncovered nailing of boarding

Partition walls must not be erected between the wooden beams of boarded floors.

If this cannot be avoided because of the distribution of rooms, the runner must be statically verified and be supported by the walls bearing the wooden beams.

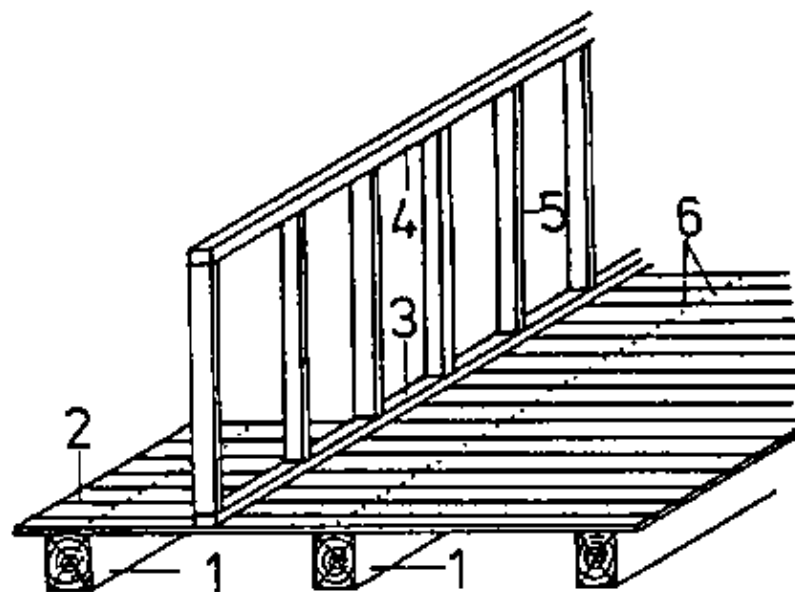

Figure 8

1 wooden beam, 1 straining direction of boarding, 3 foot runner, 4 head runner, 5 post, 6 uncovered nailing of boarding

Partition walls on wooden beam ceilings must be designed as light-weight walls. The light-weight wall comprises the wooden framework with surface covering (see Fig. 1 and Fig. 2).

Why do king posts of a roof structure limit the floor space of the rooms to be built?

What is the effect of trussed purlins?

Partition walls must not be erected between the wooden beams of boarded floors. Give reasons for this statement!

3. Surface Covering

The material of surface coverings depends on the use of the rooms.

The material applied for rooms to be used as living rooms, for example, should have a surface with no open pores or which can be subsequently refined (faced).

Suitable materials for surface coverings are:

- Plaster cardboard slabs

The surface is finished.

- Hardboard slabs

The surface is smooth and finished.

- Particle board slabs

The surface can be puttied.

- Wood–wool slabs

The surface can be faced by plastering.

The surface covering should ensure a pleasant atmosphere to live in.

A surface covering of plywood or planed boards cannot be recommended for all walls of a room but such covering on one of the four walls is conducive to a cosy atmosphere to live in.

For rooms intended for storing purposes, the sensitivity of the materials to be stored is to be considered for the wall covering which may be made of:

- plywood,
- solid wood (planed or unplaned),
- wood–wool slabs (plastered or unplastered),
- particle board slabs (puttied or unputtied).

4. Framework of the Partition Wall

The framework of the partition wall consists of the two runners with the mortised posts and their stiffening transoms. (See Fig. 12)

The width and thickness (d) of the runners and stiffening transoms must be suited to the posts.

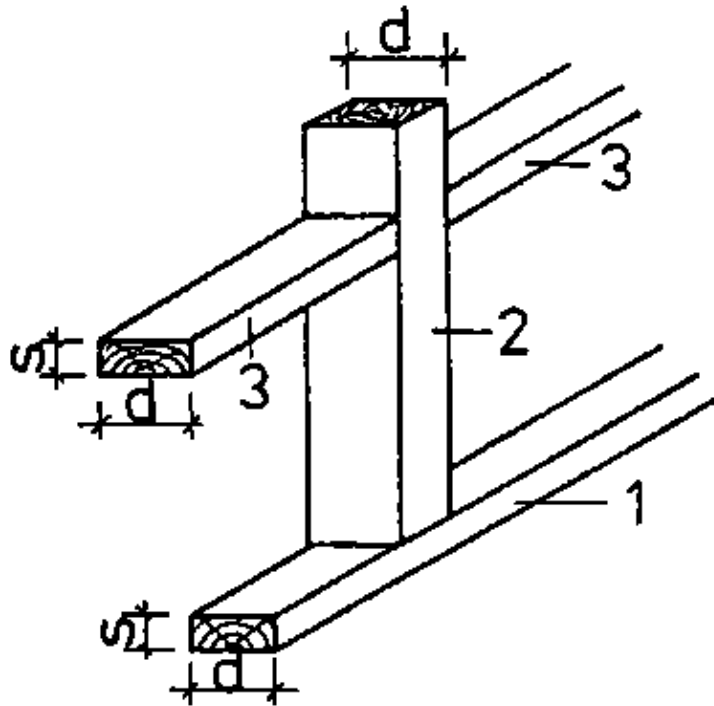

Figure 9

1 foot runner, 2 post, 3 stiffening transom

Why must the width of the runners and transoms be suited to the posts?

The runner height (s) and the height of the stiffening transoms should be 50 mm.

The posts must be sufficiently dimensioned to resist any acting horizontal forces and existing vibrations.

The dimensions of the posts depend on the room height and are shown in table 1.

Table 1: Dimensions of the posts

Room height H mm	Wx_{req} cm^3	b	d	b	d	b	d	b	d	b	d	b	d
		all sizes in mm											
1750	33	25	85	30	80	35	75	40	70	45	65	50	60
2000	38	30	87	35	81	40	75	45	72	50	67	55	64
2250	43	40	80	45	76	50	72	55	68	60	66	65	63
2500	47	50	75	55	71	60	68	65	65	70	63	75	61
2750	52	50	78	55	75	60	72	65	69	70	66	75	64
3000	57	60	76	65	72	70	69	75	67	80	65	85	63
3250	61	65	75	70	72	75	69	80	67	85	65	90	63
3500	66	65	78	70	75	75	72	80	70	85	68	90	66
3750	71	70	78	75	75	80	73	85	71	90	69	95	67
4000	74	75	77	80	75	85	73	90	71	95	69	100	67

Dimensions refer to a load of 750 N in the centre of the room height

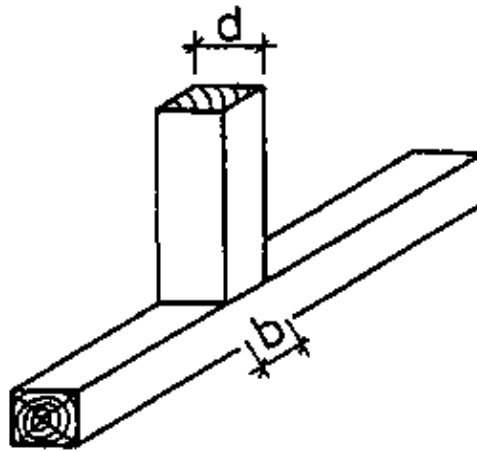

Horizontal forces may be produced in the event of accidental pushes against the wall or of collisions by objects falling off. The distances of the joint posts depend on whether the material used for the surface covering is directly fixed to the post or to additional rafters.

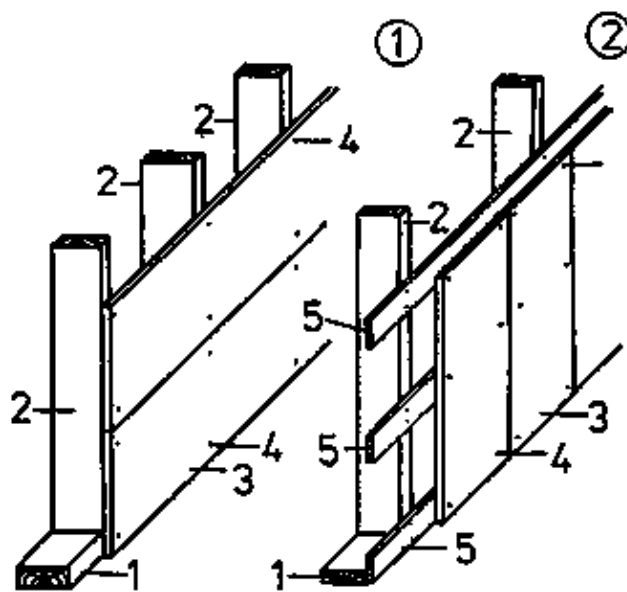

Figure 10

Fixing of the surface covering material

- (1) surface covering material directly fixed to the post
 - (2) surface covering material fixed to additional rafters
- 1 foot runner, 2 post, 3 covering material, 4 fixing means, 5 additional rafters*

If the surface covering material is directly fixed to the posts, the lengths of the material dictate the distances of the joint posts. With partition walls for rooms intended for housing purposes and where the joints are not subjected to further working, the distances of the joint posts should be symmetrical.

In such case the length of the covering material is to be shortened.

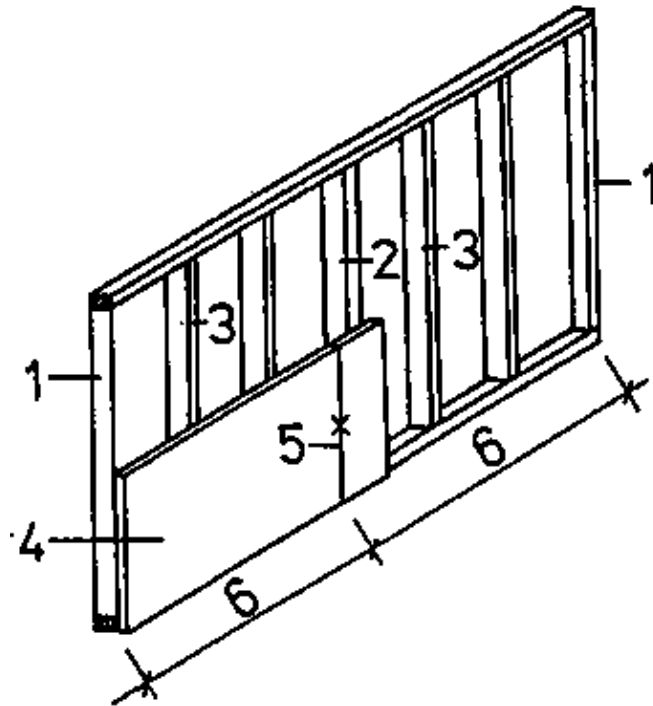

Figure 11

Symmetrical arrangement of the posts

1 wall post, 2 joint post, 3 post, 4 surface covering material, 5 shortening of surface covering material, 6 section

If the surface covering material is fixed to additional rafters, the distances of the joint posts do not matter. The symmetry of the covering can be ensured by the material used.

Irrespective of the dimensions shown in table 1, the joint posts should have a width of at least 80 mm.

Why should the joint posts have a width of at least 80 mm?

If possible, the posts between the joint posts should have equal distances so as to subject each post to equal load. Equidistant arrangement of the posts between the joint posts is all the more important if the fixing means (screws, nails) for the surface covering remain visible, otherwise the visible nail or wood screw heads would disturb the appearance of the surface covering.

The distance of the posts between the joint posts depends on the stability of the covering material. This also applies to the distance of the additional rafters.

The distance of the stiffening transoms should not exceed 1250 mm. If the height of partition walls requires several stiffening transoms, they should have equal distances.

If a door is necessary in the partition wall, it is to be included irrespective of the distribution of the posts.

For this purpose, a trimming is to be made to include the door post and door fixing post. The trimming also serves as door lintel transom.

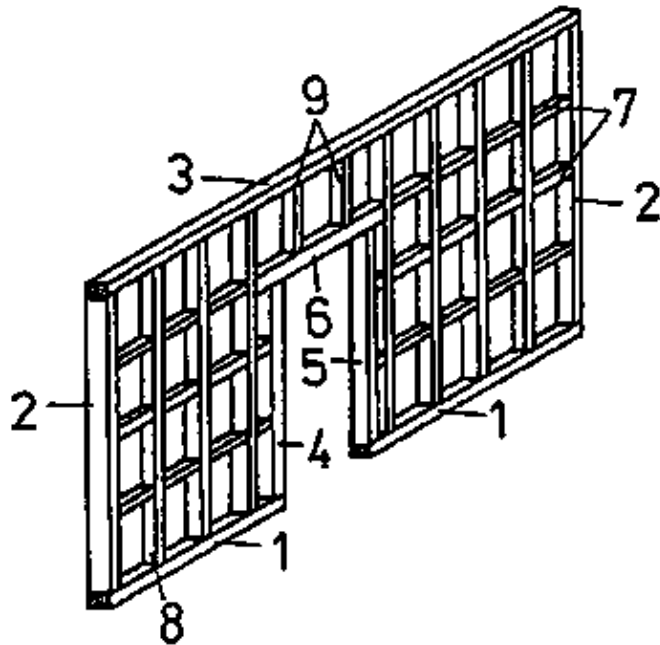

Figure 12

Inclusion of the door in the partition wall

1 foot runner, 2 wall post, 3 head runner, 4 door post, 5 door fixing post, 6 door lintel transom, 7 stiffening transom, 8 post, 9 tail post

It may also be necessary to arrange a partition wall at right angles to the wooden beam framing.

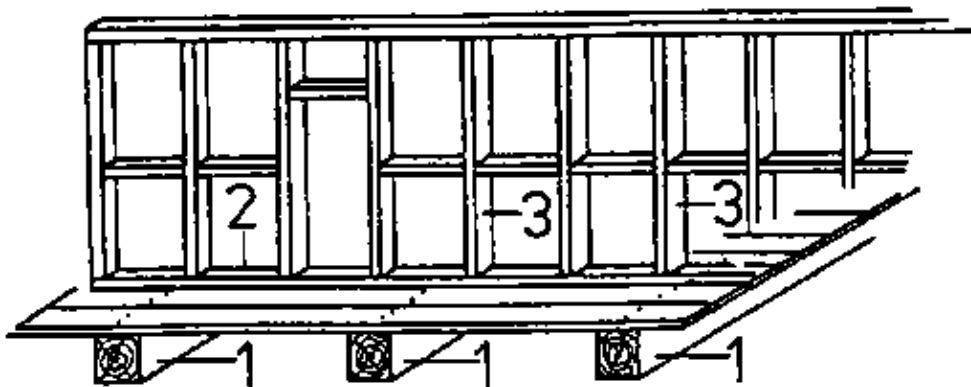

Figure 13

1 wooden beam, 2 foot runner, 3 post

If partition walls meet at right angles to each other, a corner post and an additional post are necessary in the continuous partition wall.

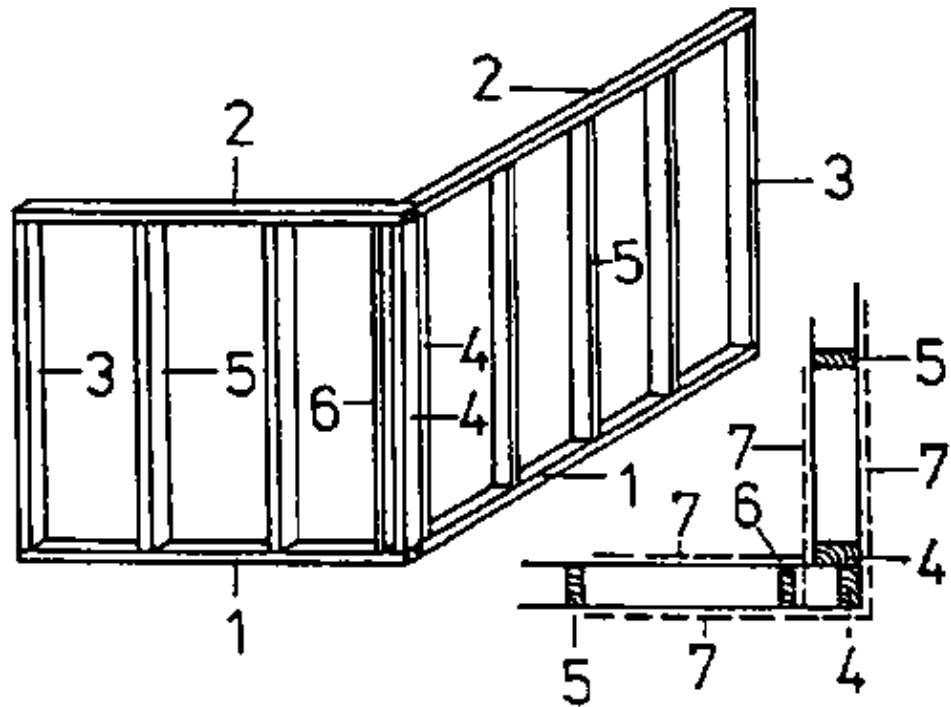

Figure 14

1 foot runner, 2 head runner, 3 wall post, 4 joint post, 5 post, 6 additional post, 7 surface covering

The additional post is not taken into account when calculating the pitch size. It serves for holding the surface covering and must be offset accordingly. The corner posts and the additional post have the same dimensions as the corner posts.

5. Calculation of the Pitch Size

Before you can start to calculate the pitch size, you have to check the perpendicularity of the walls, the horizontal of the ceiling and of the floor, the squareness of ceiling and wall and of floor and wall.

Any deviations are to be considered in the calculation of the pitch size.

For example, the distance between the wall post and the following or preceding post may be different at the head runner or foot runner.

The post at the right hand of the left wall post and the post at the left hand of the right wall post must be perpendicular.

The joint post should have a width (b) of at least 80 mm to provide a sufficient bearing surface for the surface covering material.

The width of the joint post is not taken into account when calculating the pitch size (distance of the posts from jointing to jointing). The difference of the joint post width is determined when scribing on the runners.

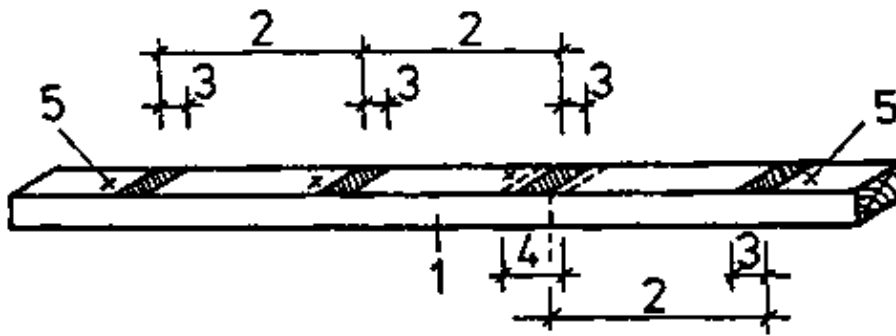

Figure 15

1 runner, 2 pitch size, 3 post width, 4 compensated joint post width, 5 jointing mark

The calculation of the pitch size is based on a symmetrical arrangement of the framework of the partition wall and is done as follows:

In the event of one joint post between the wall posts or between the wall post and the corner post:

– Read the dimensions for the posts to be used to know the width (b) of the post for the calculation!

(If posts of other width are used, take that width for the calculation).

– Divide the total length of the partition wall (G1) by the length of the covering material to be used (M1)!

The result gives the number of sections (n_T).

Formula:

$$n_T = \frac{G1}{M1}$$

If n_T is a decimal fraction, round up to the next integer number!

Subindex “a” is then added to n_T (n_{Ta})!

– Divide the total length (G1) by the rounded-up number of sections (n_{Ta})!

The result gives the length of one section (Lt).

Formula:

$$Lt = \frac{G1}{m_{Ta}}$$

– Subtract half the width ($b/2$) of the post to be used from the length of the section (Lt) and divide by the admissible distance of the post (a_{adm})!

The result gives the number of divisions of one section (n_F).

Formula:

$$n_F = \frac{Lt - \frac{b}{2}}{n_{adm}}$$

If n_F is a decimal fraction, round up to the next integer number!

Subindex "a" is then added to n_F (n_{Fa})

– Divide the length $L_t - b/2$ by the rounded-up number of divisions (n_{Fa})!

The result gives the distance of the posts (a) between the wall post and joint post or wall post and corner post.

Formula:

$$a = \frac{L_t - \frac{b}{2}}{n_{Fa}}$$

If "a" includes tenths of a millimetre, they are compensated when scribing!

Several joint posts in the framework of the partition wall

If several joint posts are required between the wall posts or between the wall and corner posts, then do not subtract half the width of the post from the section as explained in step 5 above!

Formula:

$$a = \frac{L_t}{n_{Fa}}$$

Example 1:

It is assumed that the partition wall to be built has a total length of 4000 mm and the height of the room is 2750 mm. The length of the covering material is 2200 mm. The distance of the posts must not exceed 500 mm!

What pitch size is to be scribed on the runners?

Solution:

1. Reading of the dimensions of the posts in table 1.

$b = 50$ mm, $d = 78$ mm or $b = 55$ mm, $d = 75$ mm or
 $b = 60$ mm, $d = 72$ mm or $b = 65$ mm, $d = 69$ mm or
 $b = 70$ mm, $d = 63$ mm or $b = 75$ mm, $d = 61$ mm

Decision in favour of $b = 50$ mm, $d = 78$ mm.

2. Calculation of the number of sections.

$$\text{Requ.: } n_T = \frac{G1}{M1}$$

Known: $G1 = 4000$ mm

$M1 = 2200$ mm

$$n_T = \frac{4000\text{mm}}{2200\text{mm}} = 1.08$$

$$\underline{n_{Ta} = 2}$$

3. Calculation of the number of sections.

$$L_t = \frac{G1}{n_{Ta}}$$

Requ.: L_t

Known: $G1 = 4000 \text{ mm}$

$$n_{Ta} = 2$$

$$L_t = (4000 \text{ mm})/2$$

$$\underline{L_t = 2000 \text{ mm}}$$

4. Calculation of the number of divisions: "Two sections" means one joint post!

$$n_F = \frac{L_t - \frac{b}{2}}{n_{adm}}$$

Requ.: n

Known: $L_t = 2000 \text{ mm}$

$$b = 50 \text{ mm}$$

$$n_{adm} = 500 \text{ mm}$$

$$n_F = \frac{2000\text{mm} - \frac{50\text{mm}}{2}}{500\text{mm}} = 3.9$$

$$\underline{n_{Fa} = 4}$$

5. Calculation of the pitch size:

$$a = \frac{L_t - \frac{b}{2}}{n_{Fa}}$$

Requ.: a

Known: $L_t = 2000 \text{ mm}$

$$b = 50 \text{ mm}$$

$$n_{Fa} = 4$$

$$a = \frac{2000\text{mm} - \frac{50\text{mm}}{2}}{4}$$

$$\underline{a = 493.75 \text{ mm}}$$

Result:

The pitch size to be scribed on the runners for the posts to be mortised amounts to 493.75 mm from jointing to jointing.

When scribing the pitch size on the runners, the folding rule is to be placed so as to permit continuous scribing:

$$\underline{493.75} (+493.75 =) \underline{987.5} (+493.75 =) \underline{1481.25} (+493.75 =) \underline{1975}$$

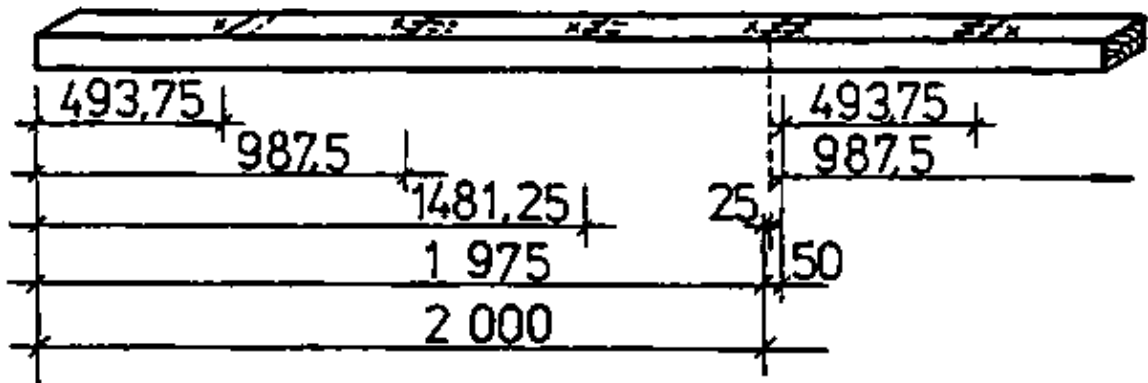

Figure 16

Example 2:

It is assumed that the partition wall to be built has a total length of 7860 mm. The room height is 2500 mm.

The distance between the posts must not exceed 400 mm.

The covering material has a length of 2000 mm.

What pitch sizes are to be scribed on the runners?

Solution:

1. Reading of the dimensions of the posts in table 1:

$$\text{Selected: } b = 60 \text{ mm, } d = 68 \text{ mm}$$

2. Calculation of the number of sections:

$$\text{Requ.: } n_T = \frac{G1}{M1}$$

$$\text{Known: } G1 = 7860 \text{ mm}$$

$$M1 = 2000 \text{ mm}$$

$$n_T = \frac{7860\text{mm}}{2000\text{mm}} = 3.9$$

$$\underline{n_{Ta} = 4}$$

3. Calculation of the section length:

$$\text{Requ.: } Lt = \frac{G1}{n_{Ta}}$$

$$\text{Known: } G1 = 7860 \text{ mm}$$

$$n_{Ta} = 4$$

$$Lt = (7860 \text{ mm})/4$$

$$\underline{Lt = 1965 \text{ mm}}$$

4. Calculation of the number of division:

$$n_F = \frac{Lt - \frac{b}{2}}{a_{adm}}$$

Requ.: n

Known: Lt = 1965 mm

$$b = 60 \text{ mm}$$

$$a_{adm} = 400 \text{ mm}$$

$$n_F = \frac{1965 \text{ mm} - \frac{60 \text{ mm}}{2}}{400 \text{ mm}} = 4.8$$

$$\underline{n_{Fa} = 5}$$

5. Calculation of the pitch sizes:

For section A – D

$$a = \frac{Lt - \frac{b}{2}}{n_{Fa}}$$

Requ.: a

Known: Lt = 1965 mm

$$b = 60 \text{ mm}$$

$$n_{Fa} = 5$$

$$a = \frac{1965 \text{ mm} - \frac{60 \text{ mm}}{2}}{5}$$

$$\underline{a = 387 \text{ mm}}$$

For section B – C

$$a = \frac{Lt}{n_{Fa}}$$

Requ.: a

Known: Lt = 1965 mm

$$n_{Fa} = 5$$

$$a = \frac{1965 \text{ mm}}{5}$$

$$\underline{a = 393 \text{ mm}}$$

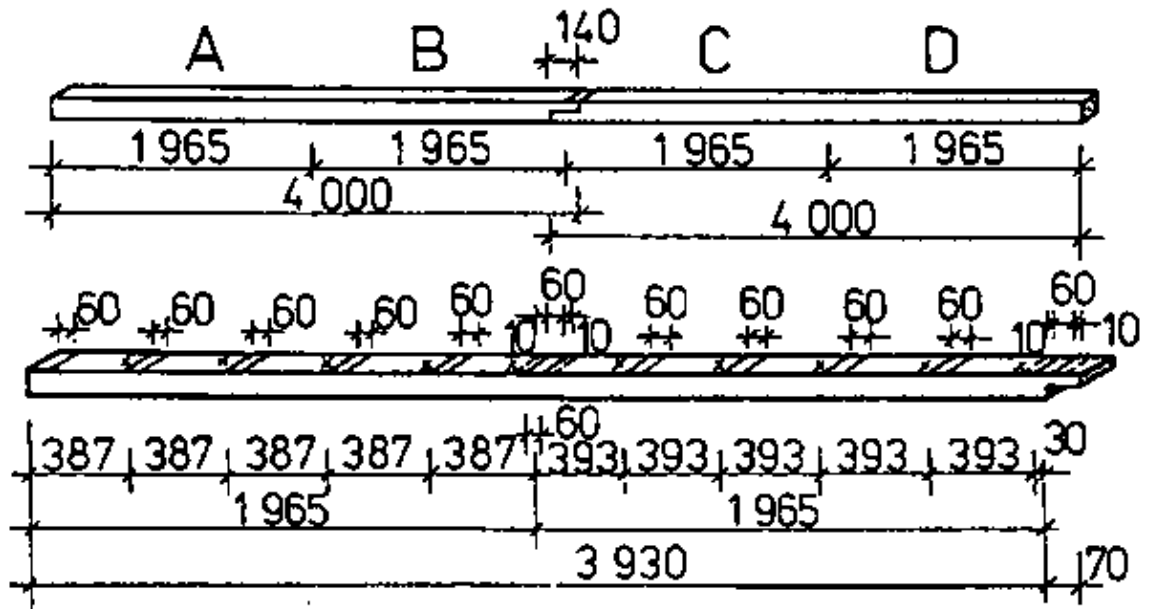

Figure 17

6. Scribing of the Structural Components

The present booklet only deals with scribing of the structural components and not with working of the necessary wood joints.

Scribing of the runners

When the pitch size for the sections has been calculated, the head and foot runners are to be inspected and the joining sides to be marked with a jointing mark.

For more efficient scribing, the runners are to be put on two one-ell trestles.

The runners are to be put on the trestles so as to ensure that the joining sides of the head runner and foot runner are facing each other, that the runners lie closely together and parallel to each other and that their left ends are flush!

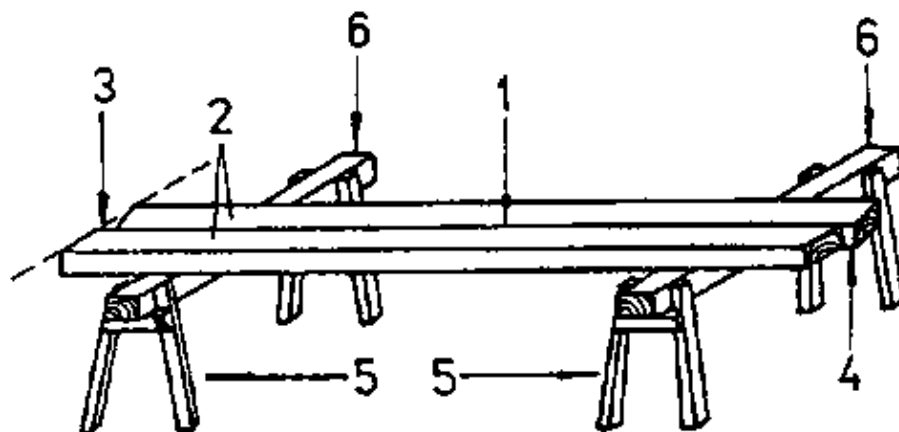

Figure 18

Runners put on the trestles

1 closely together, 2 parallel to each other, 3 about flush at the left end, 4 jointing mark, 5 one-ell trestles, 6 saddle timber (of trestle)

Why must the joining sides face each other?

By putting the runners to one another, they can be scribed together to ensure parallelism of the posts to be erected.

The following steps are recommended for scribing of the runners:

1. Scribe the shortening at the left ends and mark with section mark!
Go to the right only as far as necessary to produce a right-angle section.

2. Scribe the pitch size and mark the joining side!
The pitch size of each section is to be scribed cumulatively.¹⁾
See Fig. 16)

¹⁾ cumulative = increasing steadily in amount by one addition after another

3. Measure-in and scribe the post width!
A template is to be used having the width of the posts.
(template = master board)

4. Measure-in and scribe the joint post width!
The difference between post and joint post is to be equally distributed at both sides.
(See Fig. 17)

5. Scribe the tenon parapet and mortise width!
A commercial or self-made marking gauge is to be used for this purpose.
Do not adjust the marking gauge! It is to be used again for marking the posts and stiffening transoms!

6. Scribe the longitudinal half joints at the right ends of the runners!
Think of the fact that the upper half-joint accommodates the tenon.
(This steps may not be required in any case).

Scribing of the posts

Before the posts can be scribed, the room height and runner height (s) must be known. The runner height should be between 40 mm and 50 mm.

To determine the post length, deduct two runner heights (s) from the room height and add two tenon lengths!

A tenon length of 20 mm is sufficient.

After determining the length of the posts, inspect the posts, decide on the joining side and mark with jointing mark. The joining side should always be a side guaranteeing the evenness of the partition wall to be built.

For scribing of the posts, no more than five posts should be put on two one-ell trestles. It is important to put the posts on the trestles so that their left ends are about flush, parallel to each other and closely together and with their joining sides on top.

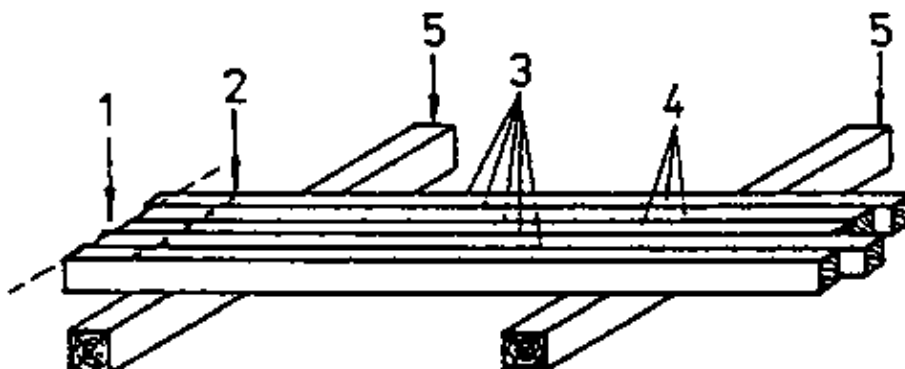

Figure 19

1 about flush, 2 jointing mark on top, 3 put closely together, 4 parallel to each other, 5 saddle timber

Proceed with scribing as follows:

1. Scribe the shortening at the left end on the front edge of the post at the front, place the square with the long leg and scribe the section line over all posts put on the trestles. (Go to the right only as far as necessary to produce a right-angle section on all posts).
2. Measure—in the tenon length, the post length and the second tenon length at the front edge of the post at the front, starting from the left section line towards the right. (Just mark the measured sizes).
3. Place the square with the leg at the post at the last right-hand marking, scribe the section line over all posts put on the trestles and mark it.
4. Check the size between the sections.
- (If the sizes are not identical, find the reason and make the necessary corrections).
5. Scribe over all posts put on the trestles all marking made at the front edge of the post placed at the front. (Make sure that the long leg of the square is placed correctly).
6. Scribe the tenon parapets.
For this purpose, the posts are to be moved apart to enable the marking gauge to be handled between them.
Starting from the joining side, the front parapet is scribed first and then the rear parapet is scribed at the left ends of the posts in the same manner.
The work flow is shown in Fig. 20 and Fig. 21.

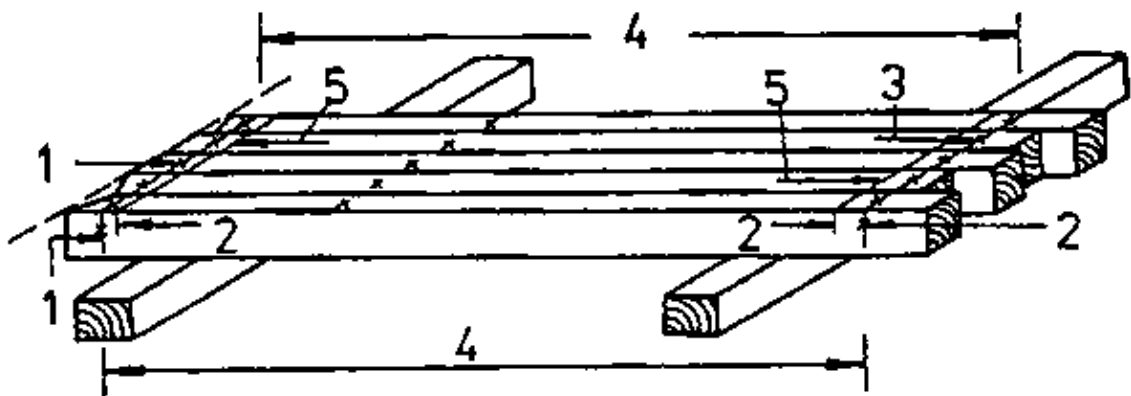

Figure 20

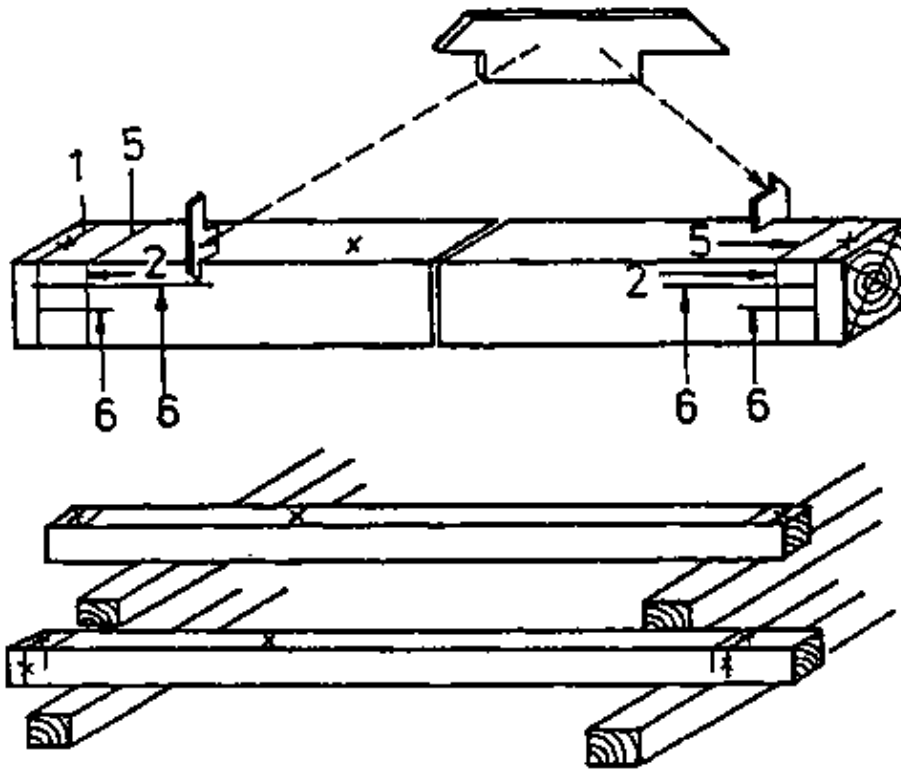

Figure 21

If more posts than those placed on the trestles are to be scribed, the post placed at the front is to be used as template!

Why is the post at the front to be used as template?

Scribing of the stiffening transoms

Scribing of the stiffening transoms is to be done in the same manner as scribing of the posts but with different length sizes. Tenon lengths of 15 mm are sufficient so as not to weaken the cross section of the posts excessively.

7. Erection of the Partition Wall

Before the partition wall is erected, the alignment is drawn on the floor. For this purpose, a line is stretched and the alignment marked at about 1000 mm intervals. The marked line is marked with marking-out mark (bird's-mouth). Since the tenons of the posts are accommodated in the mortises of the foot and head runners and the stiffening transoms are also provided with tenons, the whole partition wall is to be assembled before it is erected.

Assembling is done either flat on the floor or in inclined position supported by an auxiliary structure.

The foot runner is to be placed in parallel with and as closely as possible to the alignment. The aligned partition wall is to be moved as a whole.

When the partition wall has been erected according to the scribed markings, it is to be secured against falling off. This can be achieved by wedges to be driven in between the wall post and the wall.

When the partition wall has been secured against falling off, holes are to be bored into the foot and head runners for anchoring them.

The diameter of the holes depends on the shank diameter of the hexagon-head wood screws used for anchoring.

The distance of the holes should not exceed 1000 mm.

When placing the hexagon-head wood screws, the washers must not be forgotten.

When the screw is tightened by means of an open-jawed or ring wrench, it is to be made sure that the washer penetrates the wood of the runner together with the screw head.

8. Constructional Recommendations

- If existing walls, which the wall post is to be placed to, are not perpendicular or are bulging, the wall post may be displaced inwards. The difference of such displacement is to be taken into account when calculating the pitch size.
- If partition walls are erected between two wall posts, the sizes measured for the length of the foot and head runners should be used for the calculation of the pitch size about 20 mm smaller to avoid pressing of the framework of the wall when erecting it.
- If sound insulation is required for the partition wall to be built, all joints between the wall and the wall posts, between the ceiling and the head runner, as well as between the floor and the foot runner are to be sealed with sound-insulating material.
- Sound bridges must be avoided, otherwise it would mean a waste of the finance and material employed.
- If doors are to be included in the partition wall to be built, the door posts, door fixing posts, door lintel transom and tail posts with the respective sizes are to be scribed in the same manner as the posts (see page 17 hereof).
- If partition walls with corner posts are required, the meeting of the walls and the existing building clearance are decisive for the wall to be erected first.
- If partition walls are erected at right angles to the wooden beam ceiling, the distances of the holes for fixing the runners depend on the distances of the wooden beams.
- If foot runners are interrupted by door opening, the foot runner is to be cut only at the place of mounting so that it can be used, if in alignment, for scribing on the floor (of alignment)!
- For stabilizing the door opening on the floor, the foot runner can be held by a metal square to be additionally mounted. The leg of the square to be screwed to the floor must not be longer than the thickness of jamb lining to be provided! Long nails (4.2/100) may be used for fixing the leg of the square to the cross-grained wood of the runner.
- If partition walls are erected between solid ceilings, the runners are to be placed according to the alignment lines and the holes in the runners for fixing to ceiling and floor are to be scribed. The size is to be measured from the joining side of the runner to the centre of the hole on that side of the runner which will contact the floor or the ceiling when the partition wall is erected. This is necessary to enable dowels to be inserted or holes for straddling dowels to be bored and dowels to be driven in for fixing the runners prior to the erection.

Making of Roof Flashing – Course: Timberwork techniques. Instruction examples for practical vocational training

Table of Contents

<u>Making of Roof Flashing – Course: Timberwork techniques. Instruction examples for practical vocational training</u>	1
<u>Preliminary Remarks</u>	1
<u>Instruction Example 3.1.: Working of Boards for a Roof Base Facing</u>	1
<u>Instruction Example 3.2.: Making of a Roof Base Facing</u>	6
<u>Instruction Example 3.3.: Template Making for a Rafter Foot</u>	10
<u>Instruction Example 3.4.: Re-proofing of Buildings</u>	14

Making of Roof Flashing – Course: Timberwork techniques. Instruction examples for practical vocational training

**Institut für berufliche Entwicklung e.V.
Berlin**

Original title:

Lehrbeispiele für die berufspraktische Ausbildung
"Herstellen von Dachüberständen"

Author: Rolf Becher

First Edition © IBE

Institut für berufliche Entwicklung e.V.
Parkstraße 21–23
13187 Berlin

Order No.: 93–33–3603/2

Preliminary Remarks

The present booklet contains 4 selected instruction examples which are exclusively related to eaves flashings. Making of eaves flashings requires work on site and in the workshop as well.

The Instruction Examples 3.1. and 3.2. have been selected so that practising of the examples can be done separately or successively, one based on the other one.

Instruction Example 3.3. includes the calculations necessary for making the templates required for an eaves flashing to be made on a roof structure to be built.

Example 3.4. explains the sequence of operations in template making for re-proofing of buildings.

The necessary materials, machines, hand tools, measuring and testing means and auxiliary accessories are specified for each example to facilitate the preparation and execution of the work. Moreover, the previous knowledge, which is necessary in addition to knowledge of the technique Making of Roof Flashings, is also stated for each example and should be recapitulated at the beginning.

The order of working steps given in the sequence of operations is to be followed, in order to achieve good quality of work.

A working drawing showing the required shapes and dimensions is also attached to each example.

The working drawings 3.1. and 3.2. are required for the first two examples.

Instruction Example 3.1.: Working of Boards for a Roof Base Facing

The face and bottom boards for a couple roof base facing are to be worked.

Material

Boards with tongue and groove planed on one side, board lengths between 3000 mm and 4100 mm

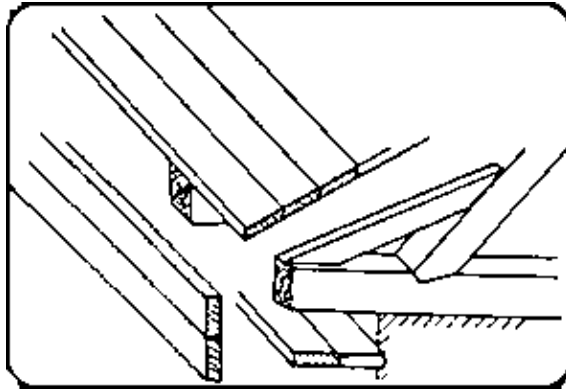

Hand tools and machines

Smoothing plane, circular saw bench

Measuring and testing means

Folding rule, measuring tape (if necessary)

Auxiliary accessories

Pencil, work bench (working table)

Necessary previous knowledge

Reading of drawings, measuring and testing, planing, operation of the circular sawing machine, fundamental arithmetic operations

Sequence of operations

1. Determine the board length.
 – 4100 mm long boards cover 5 bays
 $5 \cdot 803 \text{ mm} = 4015 \text{ mm}$

– 20 bays would be 4 board lengths
 $4 \cdot 4015 \text{ mm} = 16060 \text{ mm}$.

– Initial board

$$3 \cdot 803 \text{ mm} + \frac{160 \text{ mm}}{2} + 20 \text{ mm}$$

365 mm = 2874 mm
 Length selected: 3000 mm

– Intermediate board $5 \cdot 803 \text{ mm} = 4015 \text{ mm}$
 Length selected: 4100 mm

Final board $2 \cdot 803 \text{ mm} + \frac{160 \text{ mm}}{2} +$

–
 $20 \text{ mm} + 365 \text{ mm} = 2071 \text{ mm}$
 Length selected: 3000 mm

2. Determine the board width.
 – Lay out eaves flashing in scale 1:1, determine and measure the width:
 face boards: 120 mm width
 bottom boards: 130 mm width

Comments

Use attic framing drawing!

Roof base facing must cover the total length of the building.
 Length of building = 16990 mm.
 4 board lengths are not feasible!

Use attic framing drawing!
 Initial board over 3 bays. Beam distance from centre to centre!

over 5 bays,
 three joints = 15 bays

over 2 bays, since $3 + 15 + 2 = 20$ bays
 The difference of 929 mm is required for closing the roof base facing.

Consider maximum board width.
 See drawing of Instruction Example 3.2.
 Add about 10 mm for tongue and groove to be cut off.

3. Determine the number of boards.

- Face boards: 120 mm wide
2 • 2 = 4 boards 3000 mm long
3 • 2 = 6 boards 4100 mm long

- Bottom boards: 130 mm wide
2 • 2 = 4 boards 3000 mm long
3 • 2 = 6 boards 4100 mm long

– List of boards:

- 8 boards of 3.0 m length and 12 cm width
- 12 boards of 4.1 m length and 12 cm width
- 8 boards of 3.0 m length and 13 cm width
- 12 boards of 4.1 m length and 13 cm width.

4. Select boards of adequate length and width in timber yard.

5. Store boards according to width at the side of the circular saw bench.

6. Saw boards to width.

Board (1) 120 mm

Board (2) 120 mm + tongue length

Board (3) 111 mm + tongue length

Board (4) 110 mm

7. Chamfer boards

- Chamfer boards (1) and (4) at the groove side.
- Chamfer board (2) at the tongue side.
- Chamfer board (3) at three sides and smooth visible projection.

8. Store boards for transportation.

Use laid-out eaves flashing and determination of step 1 above.

Roof base facing is to be provided at both sides of the couple roof.

Consider surface quality, too!

Make sure that there is enough freedom to move!

Use laid-out eaves flashing.

(See drawing of Instruction Example 3.2.).

Think of tongue length.

Use stop at circular saw bench!

1 mm on board 3 is needed for smoothing of the surface.

(See drawing of Instruction Example 3.2.)

Put board flat on work bench.

Maximum chamfer 3 mm. Planed side to be on top.

Clamp board edgewise on work bench and plane off to 110 mm. Lay board flat and chamfer at tongue and groove sides.

Turn board over (rough side on top) and smooth visible areas.

Protect stored boards against possible damage during storage!

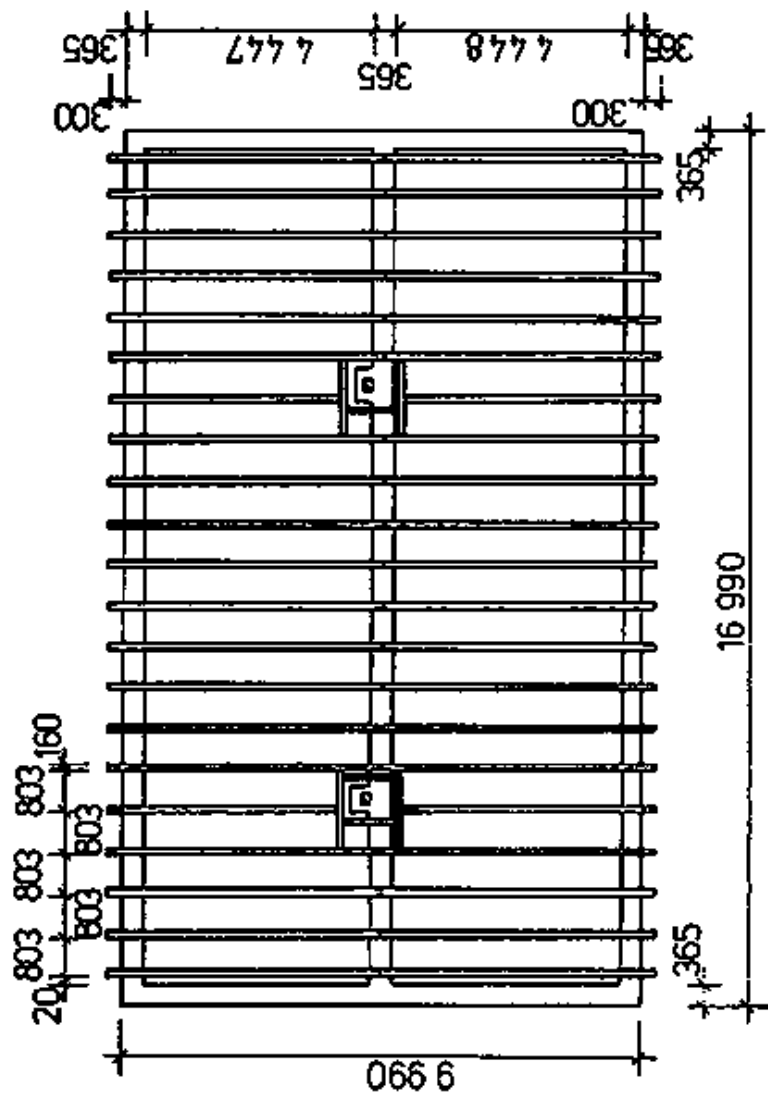

				3.1.
IBE	Attic Framing			3603

Instruction Example 3.2.: Making of a Roof Base Facing

The wooden beam heads projecting by 300 mm are to be covered by a roof base facing.

Material

Prepared face and bottom boards

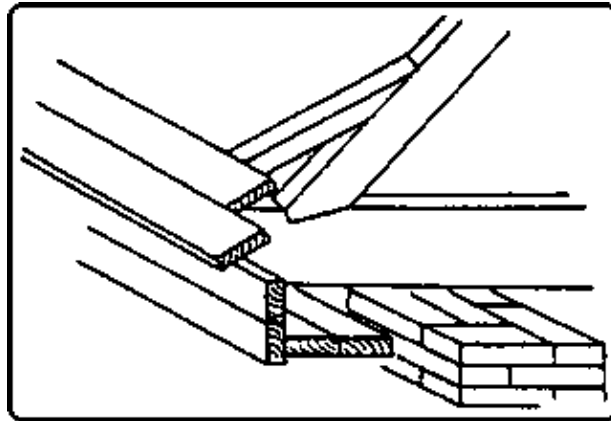

Hand tools

Hammer, frame saw, wrecking bar with claw, nail punch

Measuring and testing means

Folding rule, bevel protractor

Auxiliary accessories

Pencil, measuring rod 4015 mm long, cleat, nails 3.1/80, 2.8/70

Necessary previous knowledge

Reading of drawings, measuring and testing, sawing, scribing, nailing, nail punching.

Sequence of operations

1. Check the scaffolding.
2. Store boards on scaffolding.
Store face and bottom board, as well as different lengths separately.
3. Cut square initial board (1) at right end.
4. Place and fasten provisionally board (1).

Comments

Working direction from left to right.
Stability, bracing, covering of uprights, guard rail.

Ensure freedom of movement!

Use try square.
Saw off only as much as necessary to produce a square section.

Place right end of board centrally at 4th beam head.
Place cleat as stop at cross-grained end of beam head.
Fasten board provisionally on beam heads 1 and 3.
Use nails 2.8/70. Drive nails in only as deep as to

- | | |
|--|--|
| 5. Scribe initial board. | permit their removal later on! |
| 6. Take off initial board and scribe angular line. | Align over gable wall and scribe–mark.
Use a try square.
Don't remove provisionally fastened nails!
(Nail holes in beam heads and nails in board guarantee exact fit!) |
| 7. Saw initial board to length. | Saw square! |
| 8. Place measuring rod at initial board (1) and transfer size. | Do it exactly! |
| 9. Nail initial board (1). | Locate points of nails in the board in nail holes in the beam head and drive in the nails.
Do not completely drive in the nail at the groove side of the board to permit insertion of the tongue of board (2). |
| 10. Scribe and saw to length initial boards (2), (3) and (4). | Measuring rod to be placed flush.
Use try square.
Saw exactly square! |
| 11. Nail initial board (2). | Insert tongue in groove of board (1) and press it in with lever pressure.
Place cleat at plasterwork. Exert gentle pressure with wrecking bar.
Drive in two 2.8/70 nails per beam head.
Make sure it is flush with board (1). |
| 12. Nail initial boards (3) and (4). | Insert tongue in groove of boards and place boards.
Set marking gauge for projection (15 mm) and adjust board (3).
Make sure it is flush with board (1).
Drive in two 3.1/80 nails per beam head. |
| 13. Place measuring rod of 4015 mm length over the next beam heads and check the size. | Place it from centre to centre of beam heads.
Check over the entire facade. |
| 14. Scribe and saw to length all four boards for the other joints of the roof base facing according to the checked size. | Use a try square.
Saw exactly square. |
| 15. Nail roof base facing boards. | Nail the boards joint by joint proceeding similarly as with the first joint (initial boards). |
| 16. Saw square at left end and fasten provisionally final board (1). | Use a try square.
Do not drive in nails completely. |
| 17. Scribe length of board. | Align over gable wall and scribe size. |
| 18. Take off, scribe and saw to length final board (1). | Use a try square. |
| 19. Place measuring rod at final board and transfer length. | Place flush at one end.
Place measuring rod parallel. |
| 20. Scribe and saw to length final boards (2), (3) and (4) according to size taken. | Place measuring rod exactly.
Use a try square.
Do not let the cuttings break off when sawing off!
(Cuttings are to be used for closing the roof base facing) |
| 21. Nail final boards. | 09 Consider type of nails! |
| 22. Close roof base facing at both ends. | |

Use the cuttings.
Place, scribe, saw and insert the board pieces individually.
Use 2.8/70 nails.

23. Nail the roof base facing.

Nail in the centre of the beam bays
– through board (3) in board (1)
– through eaves board in board (4).
Use 2.8/70 nails.

24. Clean the work place.

Pick up wooden cuttings and clean scaffolding.

Instruction Example 3.3.: Template Making for a Rafter Foot

The template for the rafter foot of a purlin roof to be built shall be made and the real rafter length be determined.

Dimensions

Width of building: 8000 mm

Height of roof: 3000 mm

Cross section of rafter: 80/140 mm²

z (horizontal distance of eaves flashing) = 500 mm

n (height of inferior purlin above surface of attic beam) = 80 mm

o (square attachment timber) = 100 mm

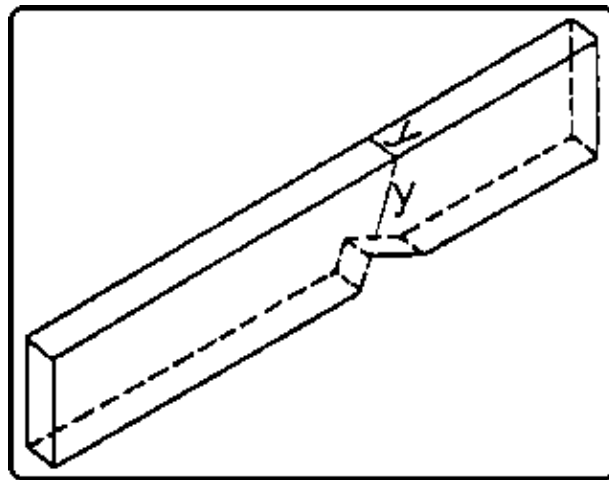

Hand tools

Frame saw

Measuring and testing means

Folding rule, carpenter's steel square

Auxiliary accessories

Paper, pencil, hand sketch, abrasive paper, board approx. 1600 mm long and 140 mm wide

Necessary previous knowledge

Reading of drawings, measuring and testing, scribing, sawing, smoothing

Sequence of operations

1. Determine real rafter length.

Req.: Spl

Known: Spl_R = b² + h²

$$y = \frac{Spl_R \cdot z}{b}$$

Comments

Formula: Spl = Spl_R + y
(See also Fig. 16 in "Trainees' Handbook of Lessons")

$$y = \frac{8000\text{mm}}{2} = 4000\text{mm}$$

$$h = 3000 \text{ mm}$$

$$z = 500 \text{ mm}$$

$$\text{Spl}_R = (4^2 + 3^2) \text{ m}^2$$

$$\text{Spl}_R = 5000 \text{ mm}$$

$$y = \frac{5000\text{mm} \cdot 500\text{mm}}{4000\text{mm}}$$

$$y = 625 \text{ mm}$$

$$\text{Spl} = 5000 \text{ mm} + 625 \text{ mm}$$

$$\text{Spl} = 5625 \text{ mm}$$

2. Determine x_0

Req.: x_0

Known: $\text{Spl}_R = 5000 \text{ mm}$

$z = 500 \text{ mm}$

$$z_1 = \frac{b(y_1 + n)}{h}$$

$$b = 4000 \text{ mm}$$

$$y_1 = \frac{\text{Spl}_R \cdot o}{b}$$

$$n = 80 \text{ mm}$$

$$h = 3000 \text{ mm}$$

$$o = 100 \text{ mm}$$

$$y_1 = \frac{5000\text{mm} \cdot 100\text{mm}}{4000\text{mm}}$$

$$y_1 = 125 \text{ mm}$$

$$z_1 = \frac{4000\text{mm}(125\text{mm} + 80\text{mm})}{3000\text{mm}}$$

$$z_1 = 273.3 \text{ mm}$$

$$x_0 = \frac{5000\text{mm}(500\text{mm} + 273.3\text{mm})}{4000\text{mm}}$$

$$x_0 = 966.6 \text{ mm}$$

3. Put straight board of approx. 1600 mm length on work bench.

x_0 is the size from the inferior purlin line up to the rafter foot, **not the length for the template!**

(See also Fig. 16 in "Trainees' Handbook of Lessons")

Formula:

$$x_0 = \frac{\text{Spl}_R(z + z_1)}{b}$$

Board width to comply exactly with rafter height.

- | | |
|--|---|
| 4. Scribe angular line at left end and mark with section mark. | Use steel square.
Go to the right only as far as to produce a square cut. |
| 5. Measure in and mark the size x_0 from the angular line. | Scribe only thin and short line. |
| 6. Measure in and scribe square attachment timber. | Do not scribe over the entire length but only scribe thin line in the area of the rafter foot line. |
| 7. Mark the size y_1 on the long leg of the square. | Scribe thin line.
Mark it at the outside of the square. |
| 8. Place square with marked size y_1 at x_0 mark and swivel the square until point of intersection with square attachment timber is reached. | Place it exactly! |
| 9. Scribe surface of inferior purlin and front face of inferior purlin. | Scribe a thicker line at the short leg of the square and a thin line at the long leg. |
| 10. Scribe front face of inferior purlin. | Place long leg of square at thin line and scribe bird's mouth depth. |
| 11. Scribe template length. | Measure from x_0 line. Use a square.
Use maximum length but at least 500 mm! |
| 12. Saw out template. | Saw exactly and perfectly square.
Special care is required for sawing the bird's mouth! |
| 13. Smooth cut surfaces with abrasive paper. | Use fine-grained abrasive paper!
Smooth very gently – no chamfers must be produced! |
| 14. Transfer scribed lines of bird's mouth to upper narrow side of template. | Scribe thin line. |

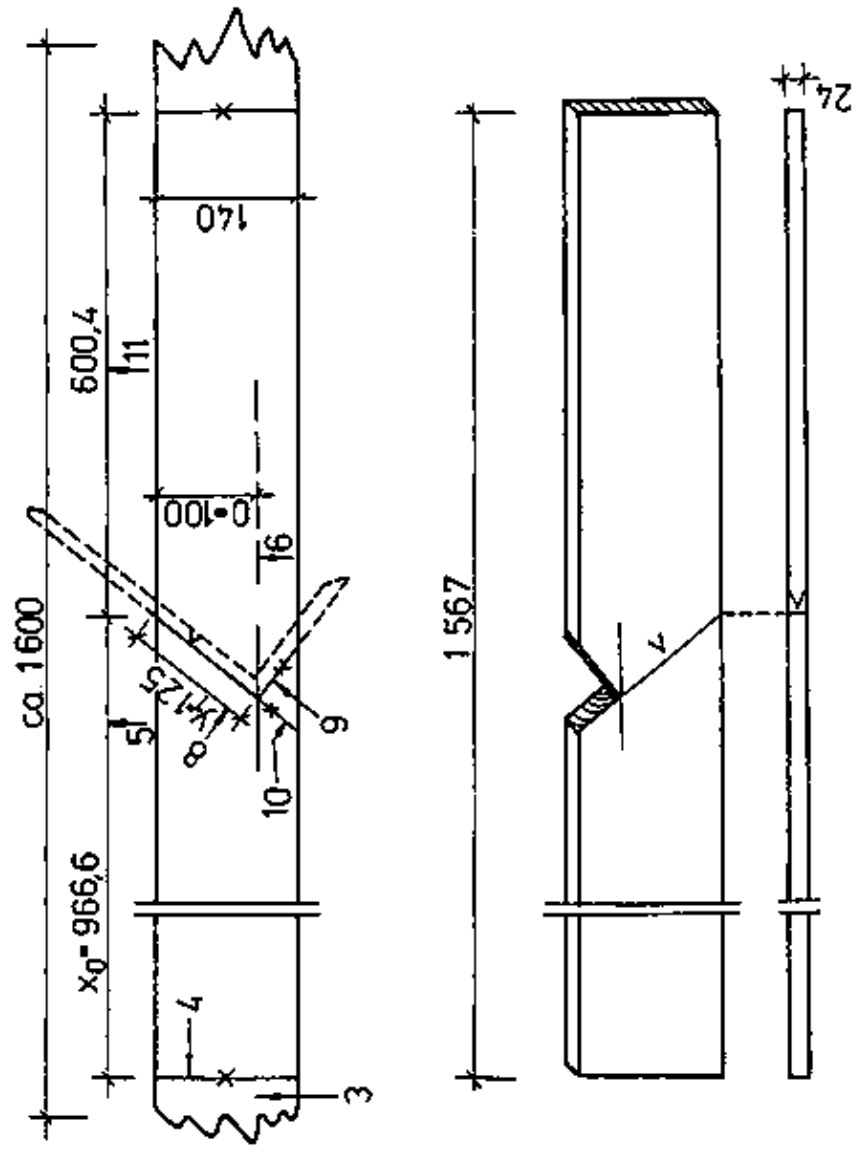

			3.3.
IBE	Template for a Rafter Foot		3603

Instruction Example 3.4.: Re-roofing of Buildings

The cover straps shall be produced for re-roofing a building by displacement of the rafter foot of a purlin roof.

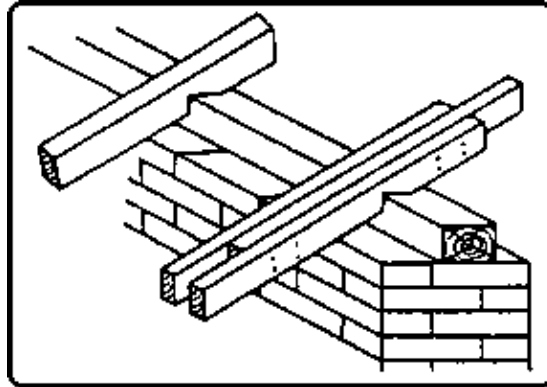

Dimensions

Cross section of roof rafter: 80/140 mm²
Thickness of cover straps: 40 mm
Horizontal distance of eaves flashing: 500 mm

Hand tools and machines

Frame saw, hand plane, bevel protractor, band saw

Measuring and testing means

Folding rule, carpenter's steel square, water level

Auxiliary accessories

Straightedge 2000 mm long, pencil, abrasive paper, board of 140 mm width and 2000 mm length

Necessary previous knowledge

Reading of drawings, measuring and testing, plumbing (perpendicularity), scribing, sawing, curving, planing, smoothing

- (1) scribed straightedge
- (2) board for template
- (3) curve of rafter foot

Sequence of operations

Steps 1 to 6 are to be carried out at the building!

1. Check the scaffolding.
2. Insert the straightedge between the roof boards and the inferior purlin and press it against the roof rafter.
3. Transfer the front face of the outside wall onto the straightedge by scribing the perpendicular line.

Comments

- Stability, bracing, covering of uprights, guard rail.
- Insert it approx. 1000 mm. Make sure that it contacts the roof boards and the roof rafter.
- Use a water level.
Check changing of water level. Mark

<p>4. Transfer front face of inferior purlin onto straightedge.</p> <p>5. Remove straightedge and insert it at several roof rafters to check the scribed lines.</p> <p>6. Count the roof rafters.</p>	<p>scribing perpendicular line with "PERPENDICULAR".</p> <p>Mark only!</p> <p>Is necessary for the number of cover straps required.</p>
<p>All other steps are to be carried out in the workshop</p>	
<p>7. Take perpendicular line from straightedge by means of bevel protractor.</p>	<p>Working direction from left to right! Set bevel protractor tongue exactly and firmly tighten the wing nut!</p>
<p>8. Put board for template (approx. 2 m long) on work bench and scribe on it square attachment timber.</p>	<p>Scribe a thin line.</p>
<p>9. Scribe angular line at right end of board and mark the section to be cut off.</p>	<p>Go only as far as necessary to produce a rectangular cut.</p>
<p>10. Measure in and mark 500 mm from angular line to the left.</p>	<p>Measure on 8.</p>
<p>11. Scribe perpendicular line through marking.</p>	<p>Use bevel protractor. Perpendicular line is front face of inferior purlin.</p>
<p>12. Scribe surface of inferior purlin.</p>	<p>Place square leg at perpendicular line so as to have point of intersection with 8.!</p>
<p>13. Take from straightedge, measure in on template and mark the size up to front face of outside wall.</p>	<p>Measure on 8.! Mark only!</p>
<p>14. Scribe perpendicular line through marking and mark with "FW".</p>	<p>"FW" means front face of outside wall.</p>
<p>15. Mark horizontal distance of eaves flashing (500 mm) at long leg of square.</p>	<p>Apply only thin marking.</p>
<p>16. Place tongue of bevel protractor at perpendicular line, displace short leg of square at tongue so as to have point of intersection at upper edge of template board!</p>	<p>Place square and bevel protractor tongue exactly. Do not squeeze the tongue of the bevel protractor! Apply only thin marking.</p>
<p>17. Scribe template length and mark the section to be cut off.</p>	<p>Use a square.</p>
<p>18. Profiling.</p>	<p>Scribe the curve so that it can be easily sawn out with the band saw!</p>
<p>19. Saw out the template.</p>	<p>Saw it out at exact angles.</p>
<p>20. Smooth the template with abrasive paper.</p>	<p>Use fine-grained abrasive paper. No chamfers must be ground!</p>
<p>21. Measure length of cover straps and select timber for cover straps in the timber yard.</p>	<p>Number of cover straps has been counted on site.</p>
<p>22. Transport the timber to the work bench and store it.</p>	<p>Ensure freedom of movement.</p>
<p>23. Put template successively on the timber for the cover straps to be produced and scribe cover straps.</p>	<p>Scribe cover straps on one side only. Place upper edges of template and cover strap flush with each other!</p>
<p>24. Saw out the cover straps.</p>	<p>Saw the curve exactly on the band saw! Observe the safety regulations for work on</p>

25. Plane the visible sides of the cover strap foot.

26. Smooth curve with abrasive paper.

27. Store cover straps for transportation.

the band saw!

Use a hand plane.
Just smooth-plane, remove small chip.

Use coarse-grained abrasive paper.

Store cover straps so that they cannot be
damaged or get dirty.

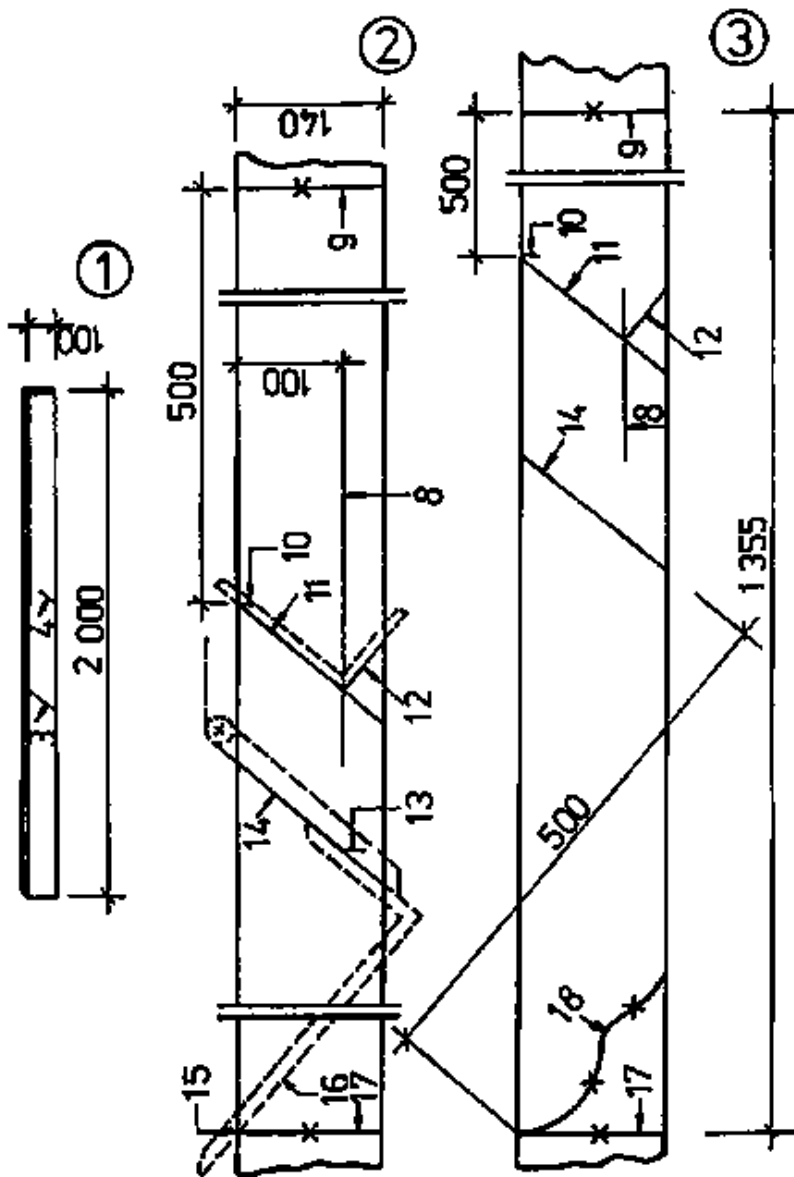

			3.4.
IBE	Re-proofing of Buildings		3603

Re-proofing of Buildings

**Making of Roof Flashing – Course: Timberwork techniques. Trainees'
handbook of lessons**

Table of Contents

<u>Making of Roof Flashing – Course: Timberwork techniques. Trainees' handbook of lessons</u>	1
1. <u>Purpose of Roof Flashings</u>	1
2. <u>Types of Roof Flashings</u>	1
3. <u>The Eaves Flashing of Couple Roofs</u>	6
4. <u>The Eaves Flashing of Purlin Roofs</u>	10
5. <u>Structural Design of Purlin Roof Eaves Flashings</u>	11
6. <u>The Suspended Gutter</u>	16

Making of Roof Flashing – Course: Timberwork techniques. Trainees' handbook of lessons

**Institut für berufliche Entwicklung e.V.
Berlin**

Original title:
“Herstellen von Dachüberständen”

Author: Rolf Becher

First Edition © IBE

Institut für berufliche Entwicklung e.V.
Parkstraße 21–23
13187 Berlin

Order No.: 93–35–3603/2

1. Purpose of Roof Flashings

Roof flashings are necessary to protect the top border of the outside walls of buildings from penetrating rain water. In the course of time, penetrated rain water would destroy the upper layers of the containing walls of buildings and render the building unusable.

If the upper layers of containing walls of buildings are soaked with moisture, this may result in efflorescence and dry rot in the brickwork.

Removal of such damage to the building is very expensive in terms of time and money. In addition to the beginning destruction of the brickwork or framework wall, moisture would penetrate into room walls. Room walls thoroughly moistened would annoy the user of the room by bad smells and damage furniture and textiles in the room. Moreover, permanent stay in such rooms with moistened walls is detrimental to the health of the room user.

But roof flashings are also important for the architectural design of the roof structure or required to make the form of the roof match the surrounding roofs.

2. Types of Roof Flashings

There are three types of roof flashings which can already be provided for in the distance of the roof structure or be made in the course of maintenance work of the building.

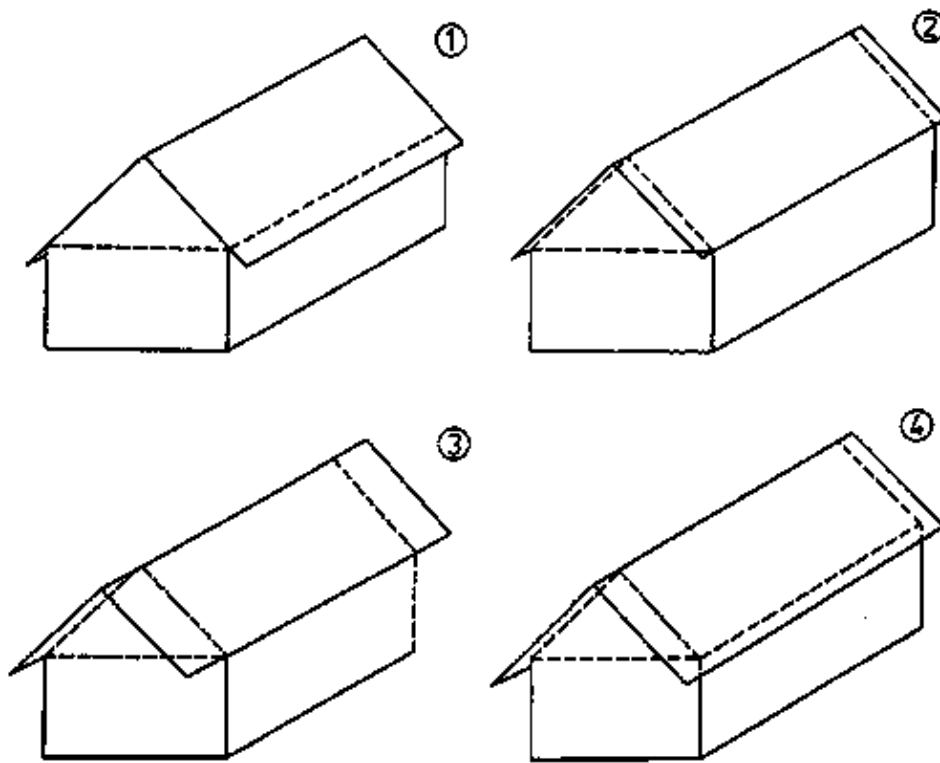

Figure 1

Types of roof flashings

- (1) eaves flashing,
- (2) verge flashing,
- (3) extended verge flashing,
- (4) extended verge flashing and eaves flashing

The verge flashing

Verge flashing is the projection of the roof boards or battens of a building the roof faces of which are bordered by verge lines.

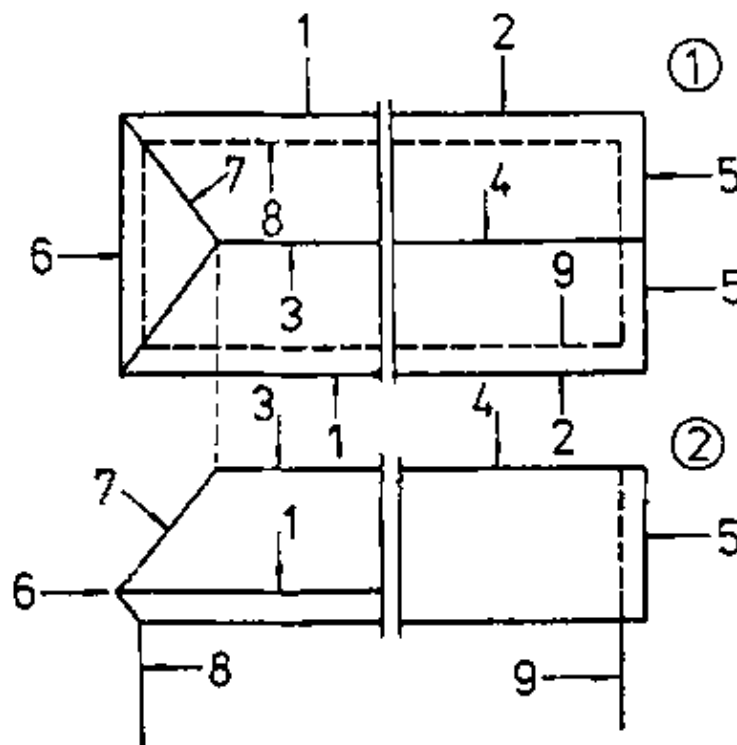

Figure 2

Bordering of roof faces

(1) top view, (2) front view

1 eaves line of main roof (hip roof), 2 eaves line of gable roof, 3 ridge line of hip roof, 4 ridge line of gable roof, 5 verge line of gable roof, 6 eaves line of hip (hip roof), 7 arris line of hip roof, 8 outside edge of containing wall (hip roof), 9 outside edge of containing wall (gable roof)

The projection of the roof boards or battens at the gable of a building should be within 150 mm to 200 mm. If roof boards are used for fixing the roofing (roofing felt, roofing slate, shingles), they are to be stabilized at the verge flashing.

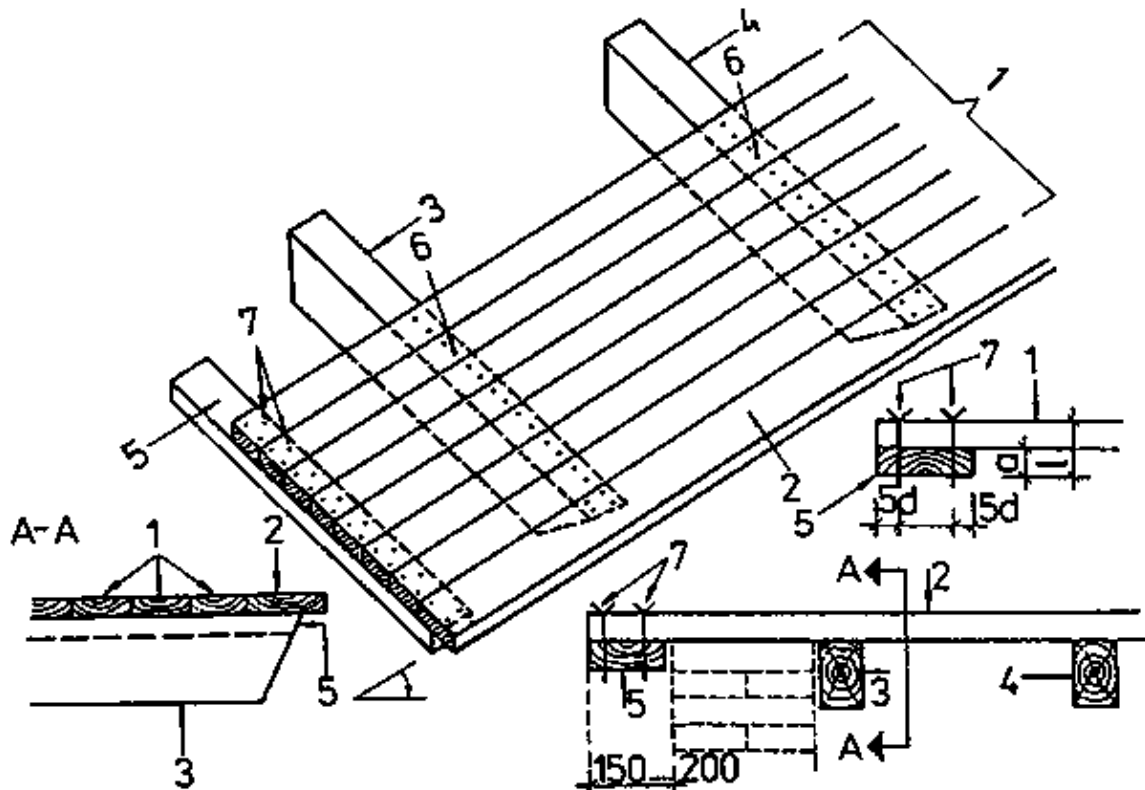

Figure 3

Verge flashing design

1 roof boards, 2 eaves board, 3 verge rafter (roof rafter at the gable), 4 intermediate rafter, 5 verge board, 6 nailing on roof rafter, 7 nailing of verge board a) projecting length of nail, d) diameter of nail shank, 1 nail length

For stabilization, a board of adequate width (= 120 mm) is nailed under the projecting roof boards. The stabilizing board must be flush at the verge. It is fixed with nails which penetrate the roof boards and the verge board and are at least 5 mm longer. The nails are driven in from above (roof boards) and staggered at an adequate distance from the edge of the verge board.

The nail end penetrating from the verge board is to be clinched with the grain.

Why must the nail be driven in from above?

Why is the penetrating end of the nail clinched with the grain?

Why are the nails driven in staggered arrangement at an adequate distance from the edge of the verge board?

If the verge flashing is not stabilized, the roofing may tear and rain water can penetrate the roofing.

In case of slated roofs the slates may loosen and leave gaps in the roofing.

What will happen when gaps are in the roofing?

To prevent the wind from driving rain water over the verge flashing, which would leave traces of the dirty dripping water on the surface of the gable, a wind plate is fixed along the verge.

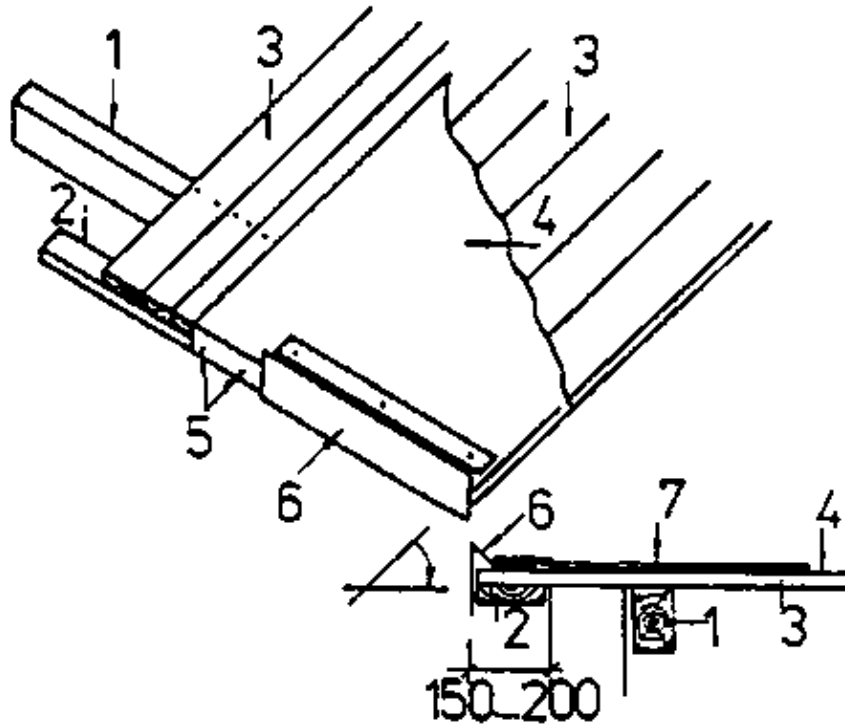

Figure 4

Wind plate at verge flashing

1 verge rafter, 2 verge board, 3 roof boards, 4 roofing felt (first layer), 5 roofing nail, 6 wind plate, 7 roofing felt (second layer, pasted)

The wind plate is nailed on the first layer of roofing felt. It must be made of non-rusting material! If the roofing consists of tiles, the roof battens must also be stabilized at the verge flashing. To prevent the wind from lifting the roofing tiles, the width of the verge board and the projection of the roof battens should be of equal size!

The extended verge flashing

An extended verge flashing can be relatively easy provided for when a new roof structure is to be built.

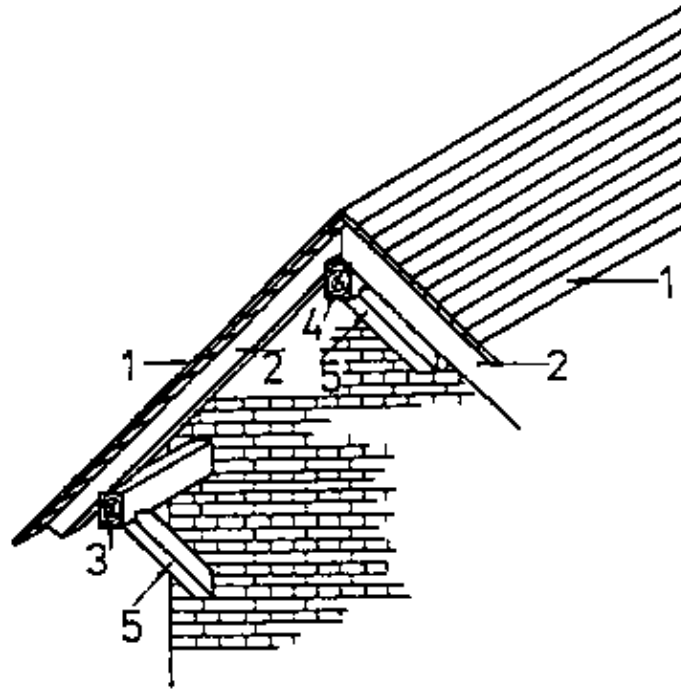

Figure 5

Extended verge flashing with eaves flashing

1 roof boards (roof boarding), 2 verge rafter, 3 inferior purlin, 4 ridge purlin, 5 brace (supporting the cantilever)

It can only be designed with a purlin roof with simple or multiple standing roof truss.

The verge rafters are supported by the purlins which are designed as cantilever and have to be calculated statically. An extended verge flashing to be made in the course of maintenance or reconstruction work would involve a lot of manual work and material.

The eaves flashing

Each roof face must have an eaves flashing.

It can be designed with both the (rafter) couple roof and the purlin roof.

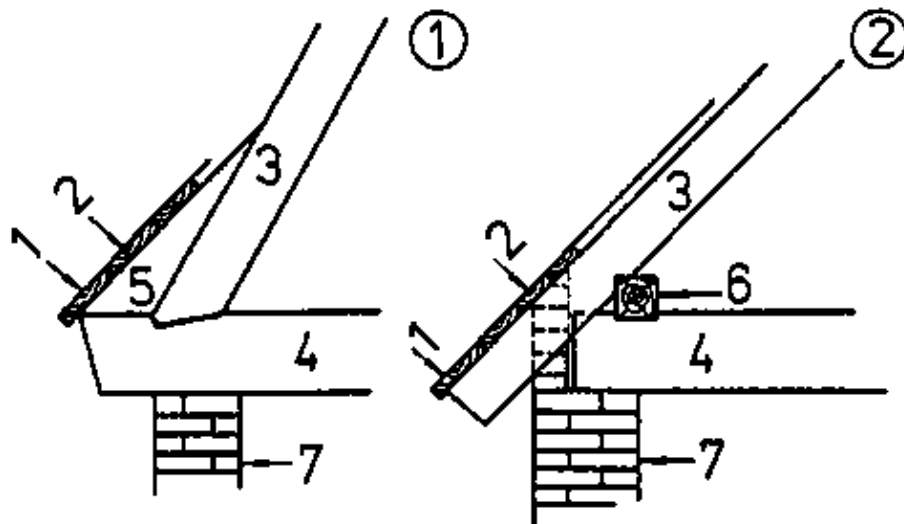

Figure 6

(1) eaves flashing of couple roof (rafter roof)

(2) eaves flashing of purlin roof

1 eaves board, 2 roof boards, 3 roof rafter, 4 wooden beam, 5 chantlate, 6 inferior purlin, 7 beam bearing

The structural design is different. The eaves flashing, if to be designed with new roof structures, can be made with couple or purlin roofs in the course of joining or, if to be designed in the course of maintenance work, with existing purlin roofs. The length of the eaves flashing is limited because of lifting wind forces to be expected. On the other hand, it must also match the architectural design of the roof structure of the building and the roof design of surrounding buildings as well.

A low facade with long eaves flashing, for example, would make a building look compressed and plain.

Also, a long eaves flashing would affect the natural incidence of light through the windows of the rooms and have an unpleasant effect on the atmosphere of the rooms.

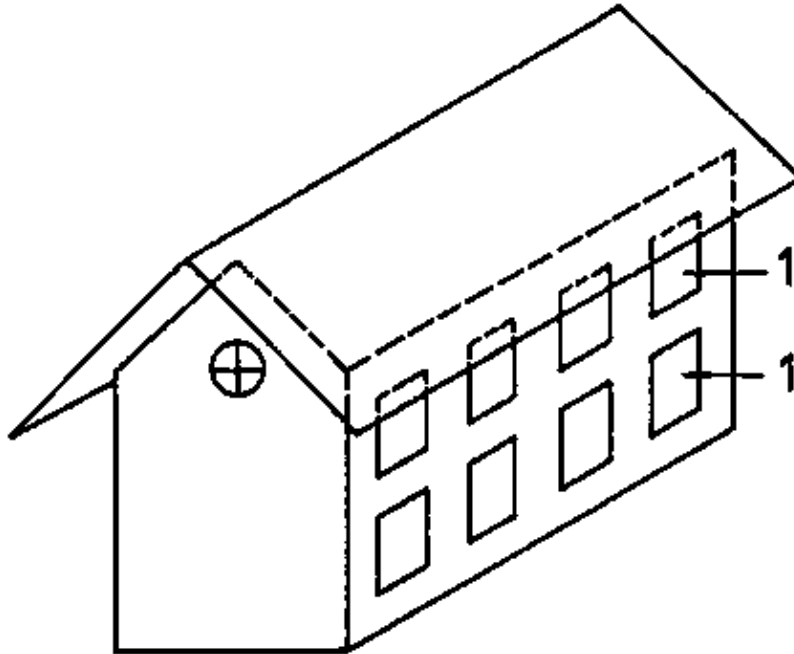

Figure 7

Long eaves flashing
1 windows

3. The Eaves Flashing of Couple Roofs

An eaves flashing of a couple roof can only be made with a roof structure to be newly built which is supported by a wooden beam ceiling.

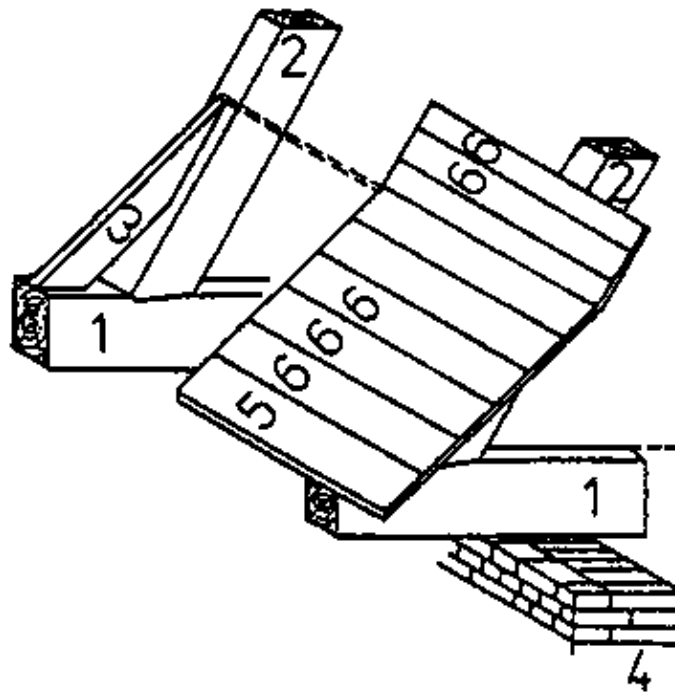

Figure 8

1 wooden beam, 2 roof rafter, 3 chantlate, 4 beam bearing, 5 eaves board, 6 roof boards

The wooden beams projecting over the outside walls can be designed with a profiled beam head or be faced by a roof base facing.

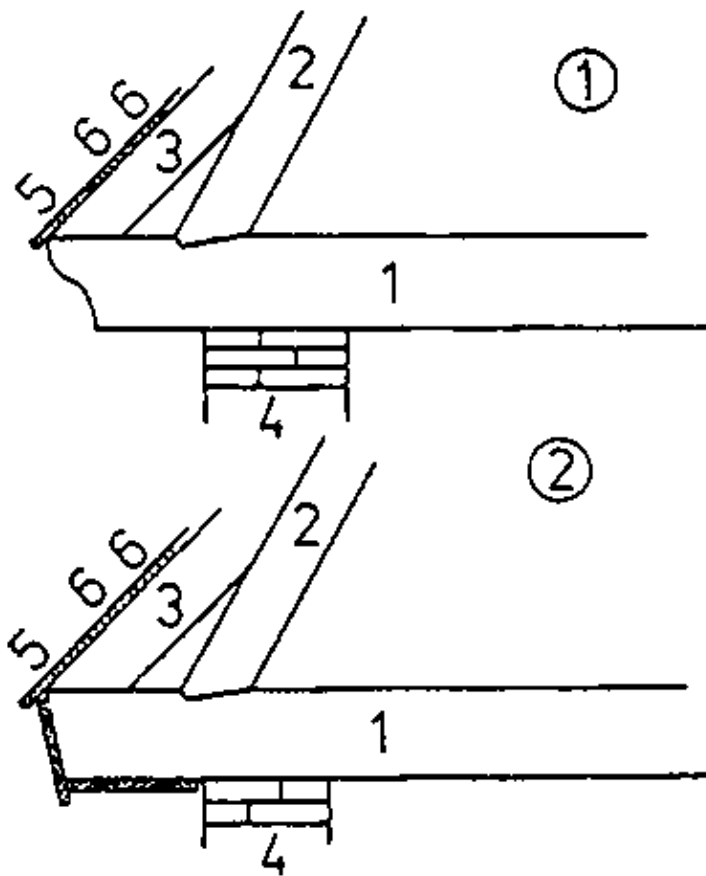

Figure 9

(1) profiled beam head, (2) roof base facing

1 wooden beam, 2 roof rafter, 3 chantlate, 4 beam bearing, 5 eaves board, 6 roof boards

The profile of the beam head is manually sawn out with a frame saw with fret saw blade or with a hand chain saw. If a hand chain saw is used, the wooden beam must be safely supported by the saw horse so that it cannot tilt when the saw is applied.

Why must the wooden beam tilt not or cant when the saw is applied?

If the beam heads are faced by a roof base facing, it is recommended to let the beam project by 300 mm and to provide the cross-grain end with a 50 mm back-off.

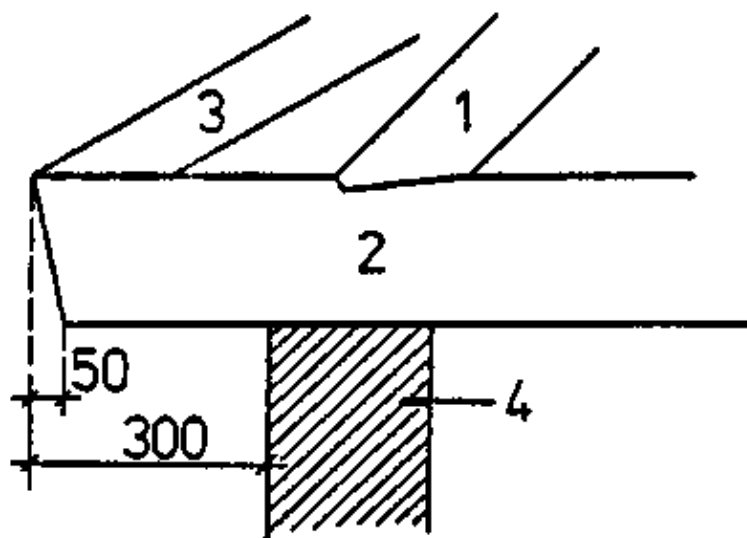

Figure 10

1 roof rafter, 2 wooden beam, 3 chantlate, 4 beam bearing

By backing off the cross-grain ends, the front face of the roof base facing can be inclined so as to make the roof base facing look more elegant.

Tongued and grooved boards of 130 mm width should be used for the roof base facing.

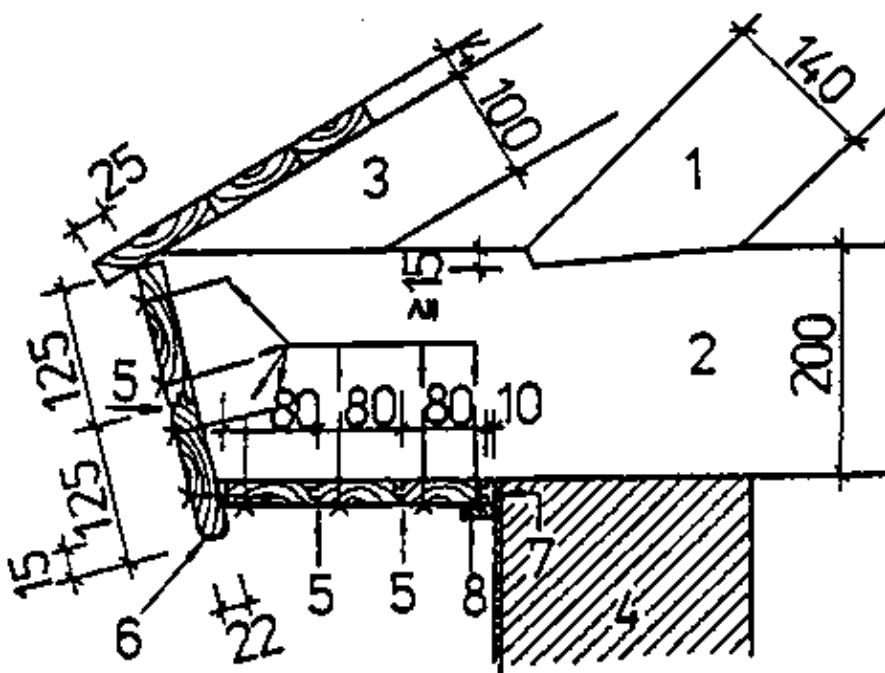

Figure 11

Structural design of roof base facing

1 roof rafter, 2 wooden beam, 3 chantlate, 4 beam bearing, 5 chamfer at the longitudinal sides of the boards, 6 chamfer at both sides of the narrow face of the board, 7 outside edge of outside wall, 8 plasterwork strip

Why should no wider boards be used for the roof base facing?

The roof base facing boards should not be forced together to allow the wood to contract and expand.

The longitudinal sides of the joined boards should be slightly chamfered to make the joint between the facing boards look better when the wood contracts or expands. The tongues of the first bottom board and face board are to be cut off to achieve a good contact with the eaves board and the face board (see. Figure 11).

The lower face board should extend 15 mm below the bottom board. The groove of this board is to be cut off and the narrow face of the board to be provided with a chamfer at both sides. The nails used for fixing the roof base facing boards are to be driven in.

An air gap of about 10 mm is to be left between the outside plasterwork and the bottom board of the roof base facing.

This air gap is covered by a plasterwork strip which is adapted to the existing unevenness of the plaster surface (see Fig. 11).

Why shall the nails be driven in?

If the couple roof is supported by a solid ceiling, the eaves flashing is achieved by a cornice connected to the solid ceiling.

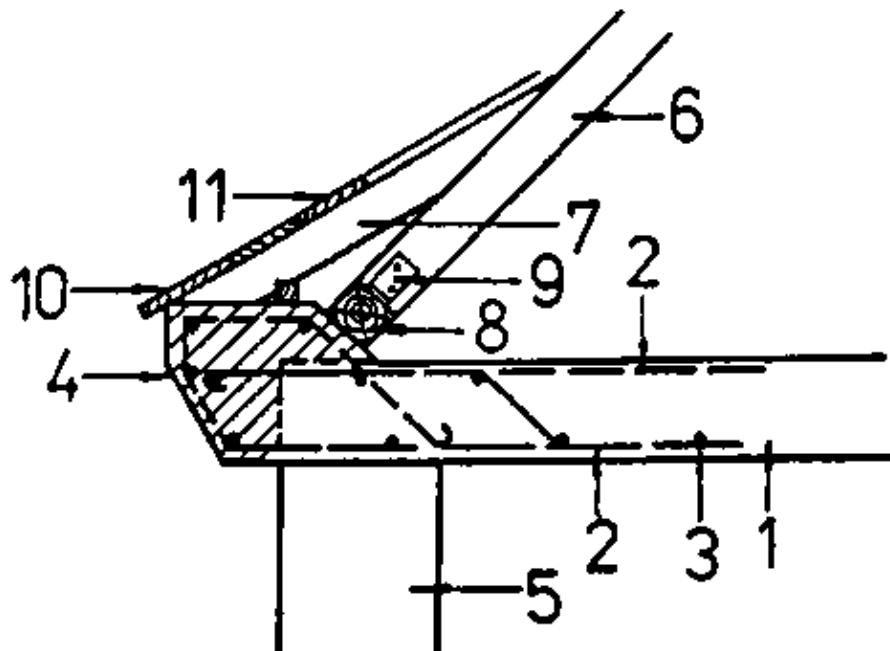

Figure 12

Cornice at solid ceiling

1 solid ceiling, 2 main reinforcement, 3 cross reinforcement, 4 cornice, 5 ceiling bearing, 6 roof rafter, 7 chantlate, 8 sleeper, 9 steel angle, 10 eaves board, 11 roof boards

4. The Eaves Flashing of Purlin Roofs

The eaves flashing of a purlin roof can be achieved by an attached cornice or by displacing the rafter foot beyond the containing wall of the building.

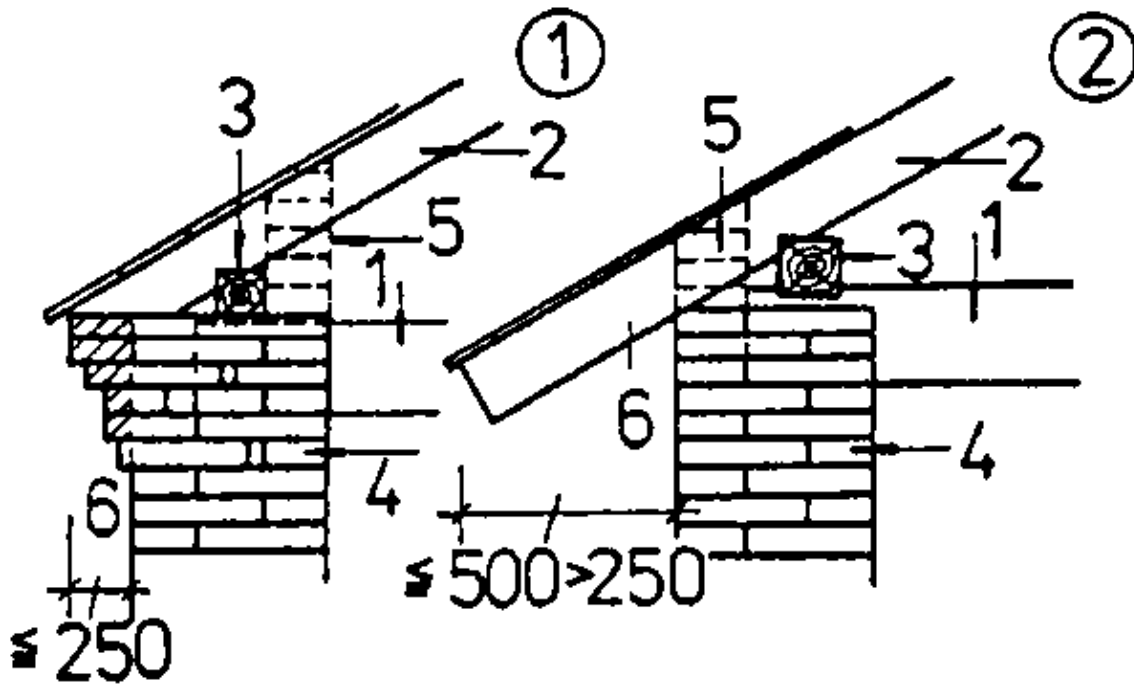

Figure 13

Eaves flashing

(1) by cornice, (2) by displacement of the rafter foot

1 wooden beam, 2 roof rafter, 3 inferior purlin, 4 containing wall, 5 extended brickwork, 6 eaves flashing

It can be designed with roof structures to be built or already existing. However, it is considerably more expensive and complicated to design eaves flashings with roof structures already existing. It is, therefore, recommended to design it only if necessary for maintaining existing buildings. The size of the eaves flashing is to be adapted to the roof form. It should not exceed 500 mm.

Why should the eaves flashing not exceed 500 mm?

The rafter foot can be rough, planed on three sides, profiled or covered by a roof base facing.

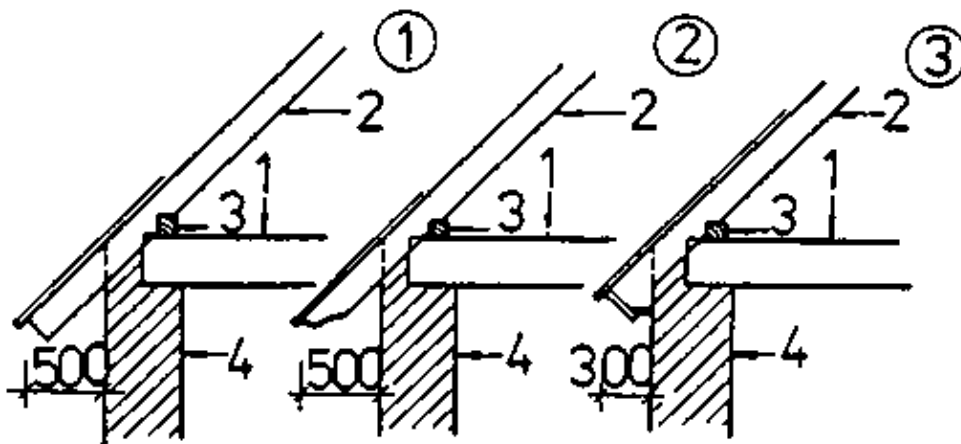

Figure 14

(1) non-profiled eaves flashing, (2) profiled eaves flashing, (3) eaves flashing with roof base facing
 1 wooden beam, 2 roof rafter, 3 inferior purlin, 4 containing wall

If the rafter feet are faced by a roof base facing, it is recommended that the horizontal distance of the flashing does not exceed 300 mm (see Fig. 14 (3)).

The bottom boards of the roof base facing should be arranged horizontally because this will make the base facing look better.

5. Structural Design of Purlin Roof Eaves Flashings

When an eaves flashing of a purlin roof is to be designed, there is a difference in designing it for a roof structure to be built or for a roof structure already existing and to be provided with a flashing in the course of maintenance of the building.

Eaves flashing of a roof structure to be built

In this case it is relatively easy to provide an eaves flashing because rafters can be used which are extended by the size of the eaves flashing. The size of the eaves flashing, however, is to be measured from the outside face of the containing wall!

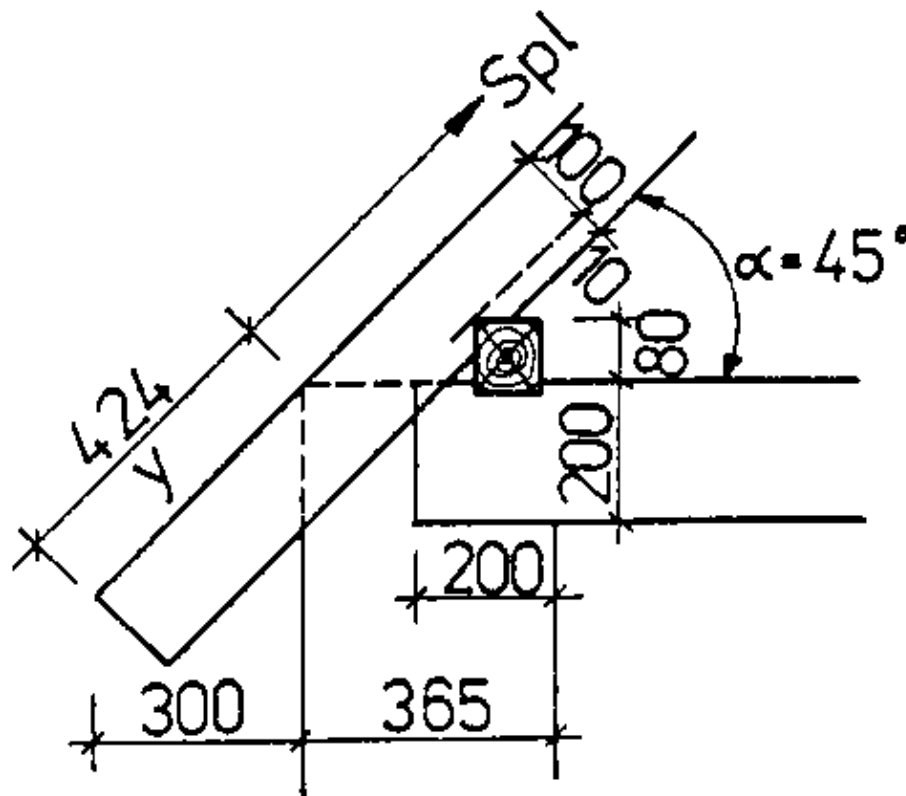

Figure 15

Laid-out eaves flashing
 Spl roof rafter length, y roof rafter extension

The difference (y) can be taken from a detail drawing in the scale 1:1 or be laid out in the scale 1:1. It is also possible to calculate the eaves flashing.

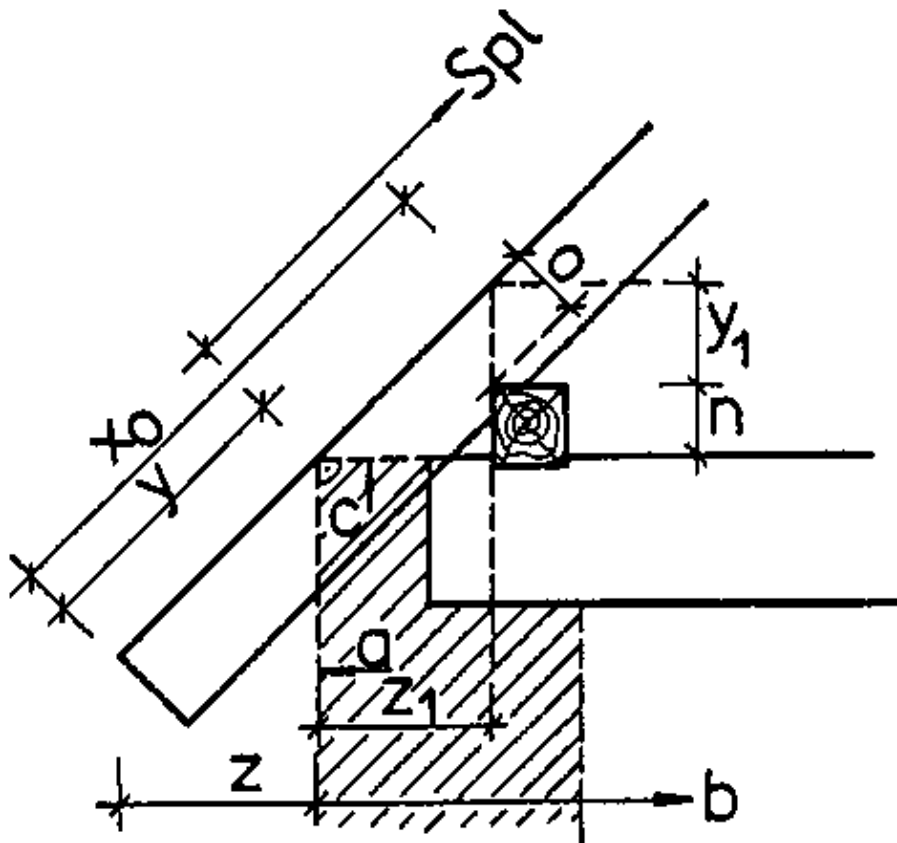

Figure 16

When the surface of the attic beam and the front face of the outside wall are square to each other and have a joint point of intersection with the surface of the roof rafter, the calculation is based on the following:

$$y = \frac{Spl_R \cdot z}{b}$$

$$x_0 = \frac{Spl_R(z + z_1)}{b}$$

- y – extension of roof rafter length
- z – horizontal distance of eaves flashing
- b – half the width of building
- z₁ – secondary size (auxiliary size)
- x₀ – joining size (length from inferior purlin line to roof rafter foot)
- Spl_R – roof rafter length from calculation
- a – surface of attic beam
- c – front face of outside wall

$$Spl = Spl_R + y$$

$$Spl_R = b^2 + h^2$$

- Spl – real rafter length
- h – roof height

$$z_1 = \frac{b(y_1 + n)}{h}$$

y_1 – perpendicular attachment timber
 n – height of inferior purlin above surface of attic beam

$$y = \frac{Spl_R \cdot o}{b}$$

o – square attachment timber

Eaves flashing for an existing roof structure

This structural design is mainly used in connexion with maintenance of existing buildings. For example, if a dilapidated cornice is broken involving the danger of falling down, proofing of the building can be achieved again by an extending rafter foot.

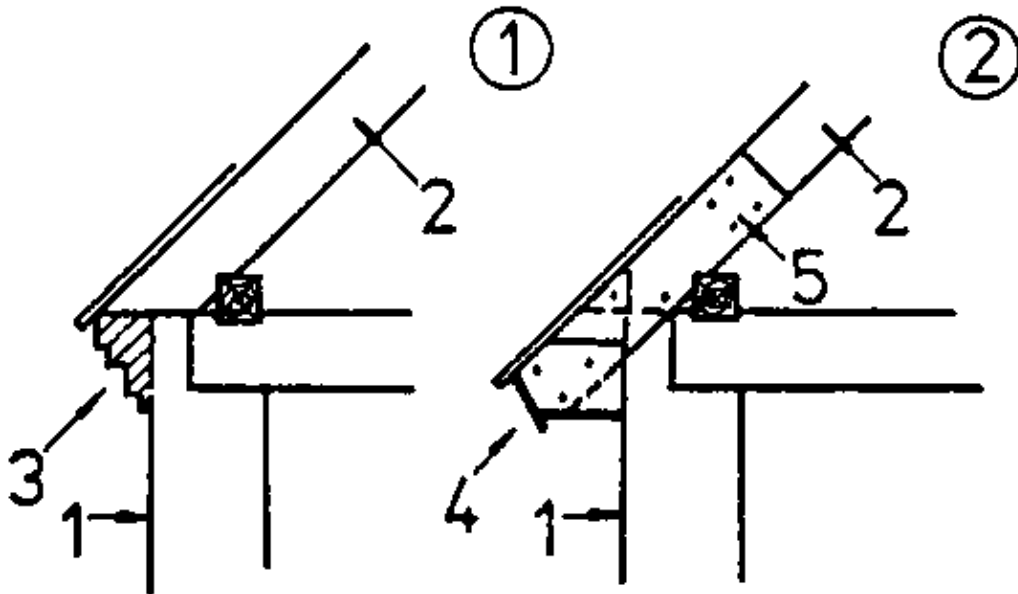

Figure 17

(1) dilapidated cornice, (2) new eaves flashing
 1 containing wall, 2 roof rafter, 3 cornice, 4 roof base facing, 5 nailed cover strap

Proofing of the building can also be achieved by displacement of the rafter foot.

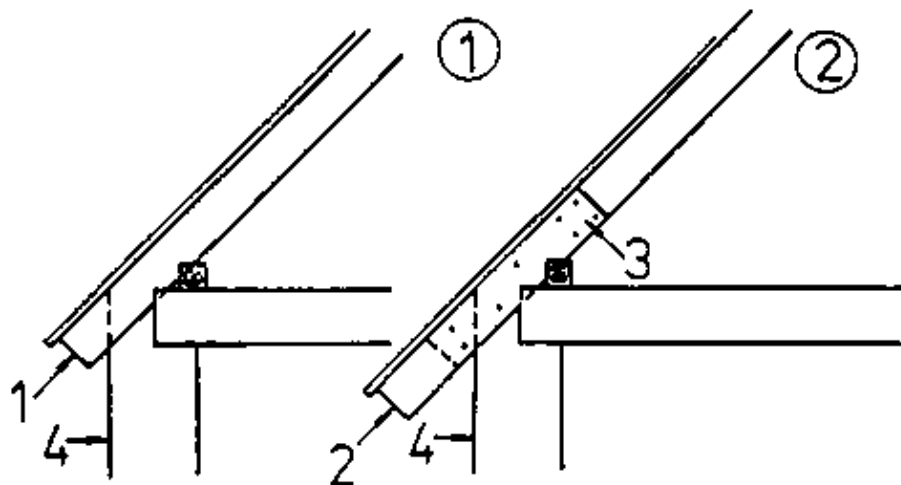

Figure 18

Re-proofing of buildings

(1) former eaves flashing, (2) new eaves flashing
 1 rafter foot, 2 displaced rafter foot, 3 nailed cover strap, 4 containing wall

In both cases displacement of the rafter foot can be implemented by nailing cover straps laterally onto the roof rafter. It is recommended to cover the eaves flashing by a roof base facing.

Why is a roof base facing to be recommended?

The cover straps to be nailed on must be sufficiently long and be birdsmouthed to the inferior purlin.

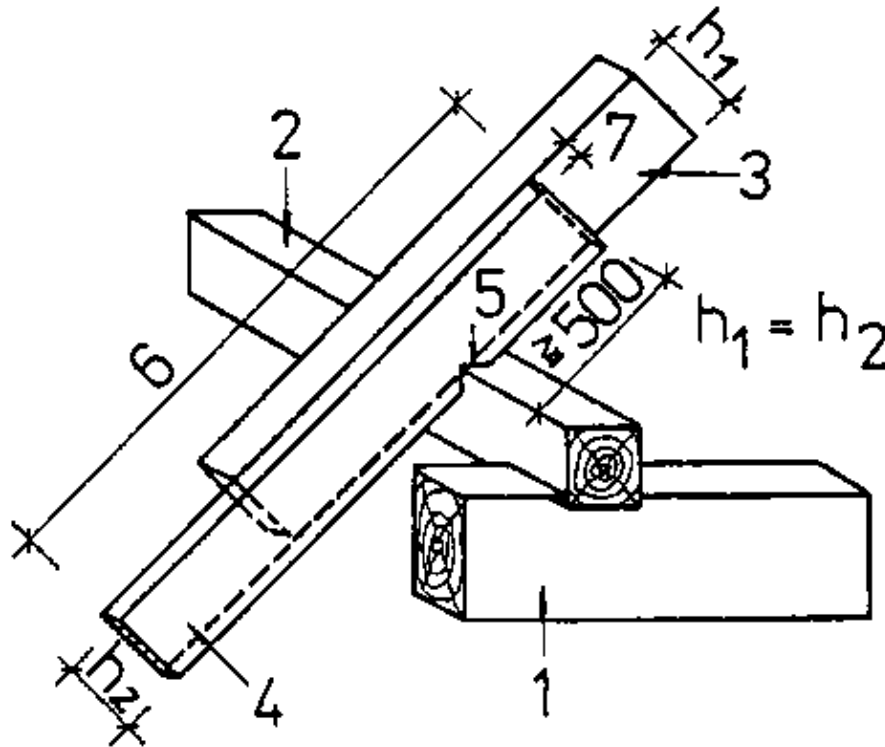

Figure 19

1 wooden beam, 2 inferior purlin, 3 roof rafter, 4 cover strap, 5 birdsmouth, 6 length of cover strap, 7 thickness of cover strap, h height of roof

The width of the cover strap must be equal to the roof rafter height and the thickness should be 40 mm to 50 mm. The length of the nails to be used for nailing the cover strap to the roof rafter should be equal to or greater than the thickness of the cover strap. Keeping an adequate distance of the nails, groups of at least four nails each should be driven-in above and below the inferior purlin.

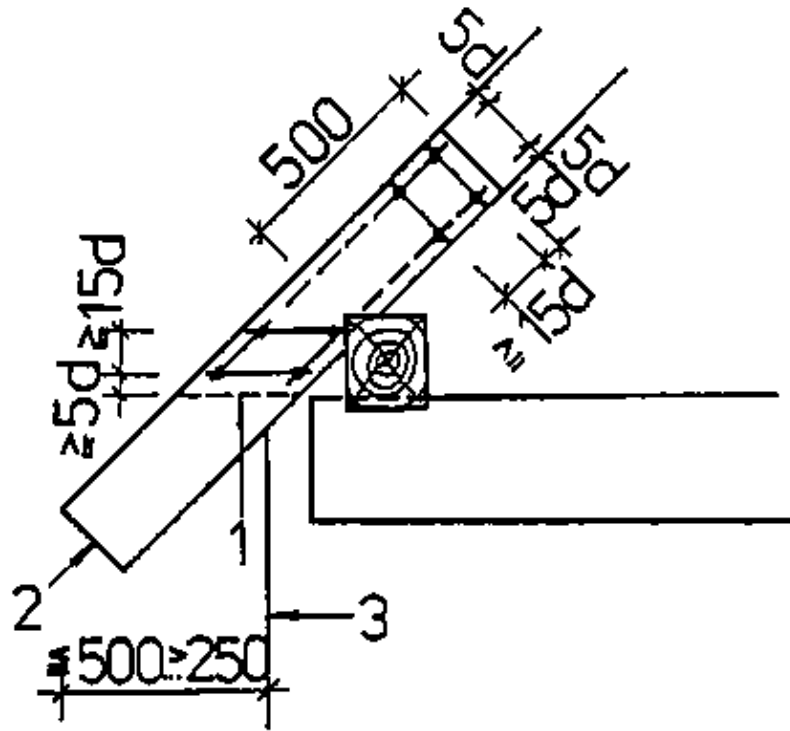

Figure 20

Arrangement of nail groups

1 former rafter foot, 2 extended rafter foot, 3 front face of outside wall
d diameter of nail shank

In order to be able to fix the boards for the roof base facing, cleats complying with the profile of the roof base facing are to be nailed to the cover straps.

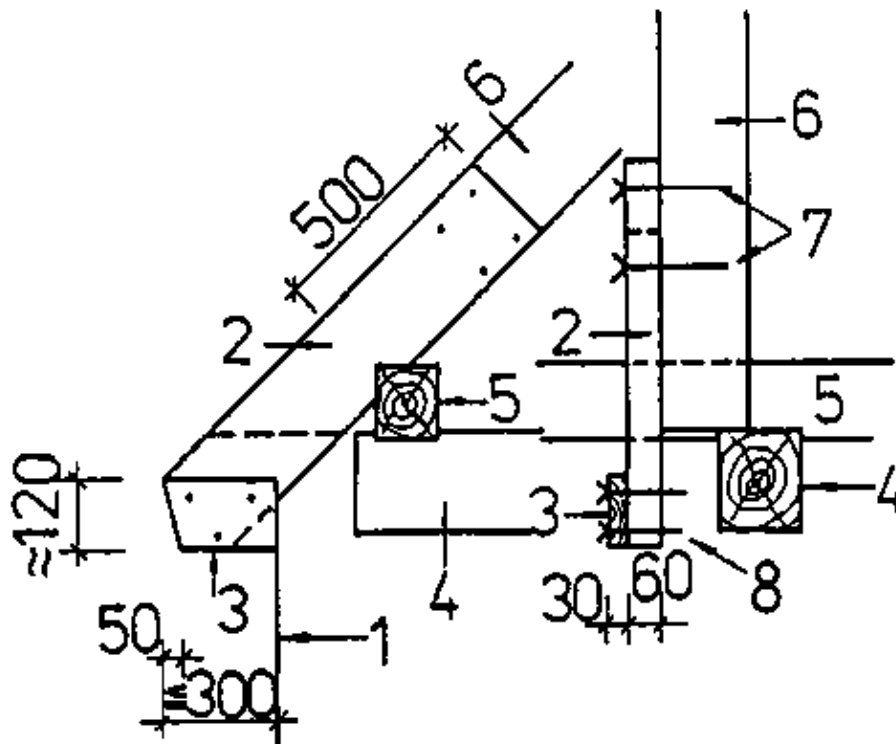

Figure 21

1 front face of outside wall, 2 cover strap, 3 cleat, 4 wooden beam, 5 inferior purlin, 6 roof rafter, 7 nails for cover straps, 8 nails for cleats

For this purpose, nails are to be used which are long enough to penetrate the two timbers and can be clinched with the grain of the wood.

Why must the nails be clinched?

The two gable sides of the roof base facing are to be closed. For this purpose, pieces of boards complying with the profile of the roof base facing are to be inserted and nailed.

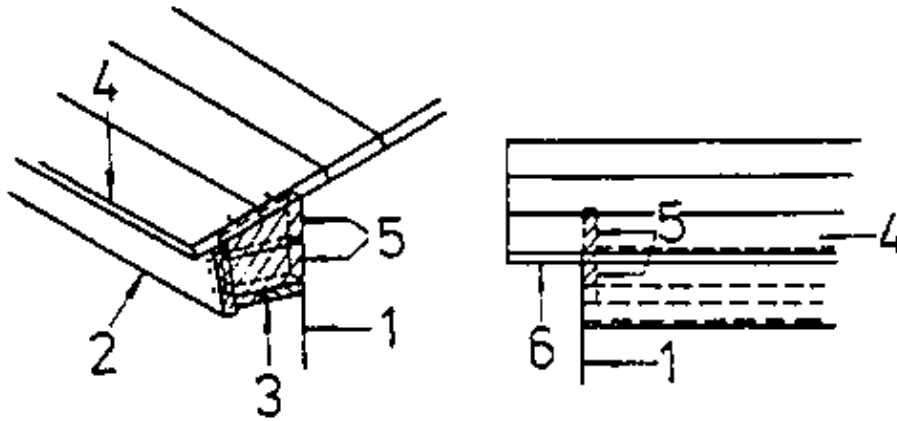

Figure 22

Closing of the roof base facing

1 front face of outside wall. 2 face of roof base facing, 3 bottom of roof base facing, 4 eaves board, 5 inserted board pieces, 6 verge flashing

Why must the two gable sides be closed?

6. The Suspended Gutter

To prevent the rain water from flowing down the eaves flashing, a gutter is suspended from the eaves.

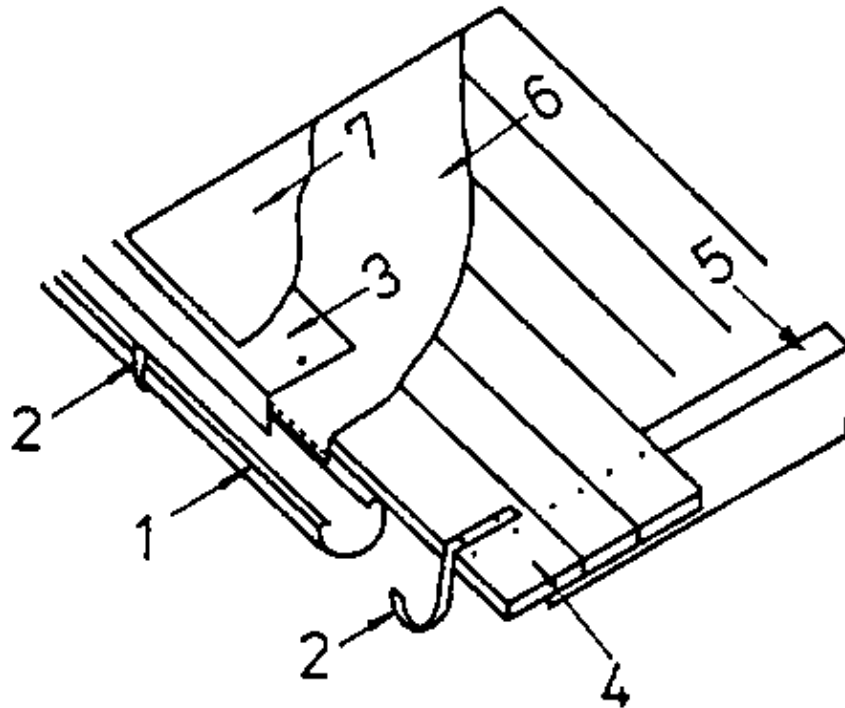

Figure 23

Suspended gutter

1 gutter, 2 gutter bracket, 3 cover plate, 4 eaves board, 5 roof rafter, 6 first layer of roofing felt (nailed), 7 second layer of roofing felt (pasted)

The gutter brackets to hold the gutter are sunk in into the eaves board and screwed to it.

The covering plate is nailed to the first layer of roofing felt. It extends into the gutter to prevent rain water from running down between the cover plate and gutter.

The gutter brackets, the gutter and the cover plate must be made of non-rusting material.

The second layer of roofing felt is not nailed but pasted with bitumen on the first layer. It ends on the covering plate.

**Stairmaking – Course: Timberwork techniques. Instruction examples
for practical vocational training**

Table of Contents

<u>Stairmaking – Course: Timberwork techniques. Instruction examples for practical vocational training</u>	1
<u>Preliminary Remarks</u>	1
<u>Instruction Example 8.1.: Taking off Dimensions at the Stairwell</u>	1
<u>Instruction Example 8.2.: Determination for the Ratio of Rise and Tread</u>	4
<u>Instruction Example 8.3.: Scribing of landing connections</u>	6
<u>Instruction Example 8.4.: Manufacture of Template and Angular Board</u>	10
<u>Instruction Example 8.5.: Scribing and Preparing the Stair Strings</u>	12
<u>Instruction Example 8.6.: Manufacture of Steps and Risers</u>	17
<u>Instruction Example 8.7.: Assembly of the Stair Flight</u>	18

Stairmaking – Course: Timberwork techniques. Instruction examples for practical vocational training

Institut für berufliche Entwicklung e.V.
Berlin

Original title:

Lehrbeispiele für die berufspraktische Ausbildung
"Herstellen von Treppen"

Author: Rolf Becher

First Edition © IBE

Institut für berufliche Entwicklung e.V.
Parkstraße 21/23
0-1100 Berlin

Order No.: 93-33-3608/2

Preliminary Remarks

The present booklet contains 7 selected instruction examples to practise and consolidate knowledge and skills in the manufacture of straight mortised wooden stairs with two branches of flights.

The instruction examples have been selected so that the individual exercises can be practised separately or successively, one based on the previous one.

The hand tools, measuring and testing tools and auxiliary accessories as well as the previous knowledge required are stated for each instruction example. The previous knowledge is necessary in addition to knowledge of the "stairmaking" technique and should be recapitulated at the beginning. The sequence of operations specified for each example gives the order of working steps leading to the manufacture of the respective stair components or calculations.

A working drawing showing the required shapes and dimensions of the stair components and auxiliary accessories is attached to each example. The necessary explanations to the working drawing are given prior to the description of the sequence of operations.

For acquiring and practising the skills to be developed it is recommended to manufacture the stair components in the workshop in the scale 1: 2.5.

Instruction Example 8.1.: Taking off Dimensions at the Stairwell

A stairwell for straight mortised stairs two opposed branches of flights (180 degrees' turn) and with landing is to be measured in order to compare the dimensions with the drawing.

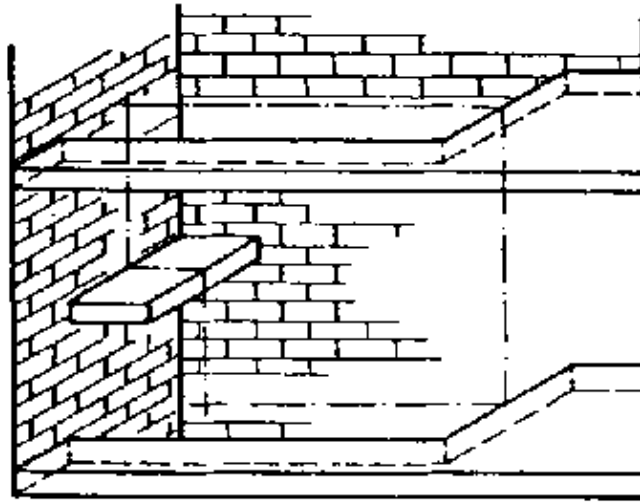

Hand tools

Hammer, hand saw

Measuring and testing means

Folding rule, water level, hanging plumb, straightedge, builder's square

Auxiliary accessories

Pencil, battens to transfer the sizes

Necessary previous knowledge

Reading of drawings, measuring, plumbing, levelling, aligning, scribing

Explanations to the working drawing

In stairmaking, it is never the stairwell that is shown in a drawing but always the stairs to be built into it.

Sequence of operations	Comments
1. Draw a hand-sketch.	Draw the dimensions lines only. Draw the plan view and sectional view.
2. Put the builder's square on the upper ceiling at the opening intended for the stairs to be built in and check for squareness.	Apply the longer leg at the stair range. If necessary, determine the right angle and note down in the sketch.
3. Measure a gauge size on the straightedge and scribe-mark.	Use a size corresponding to the decimetric system, such as 1.0m, 1.1 m, 1.20 m etc. Write the gauge size into the hand-sketch.
4. Wind up the plumb cord and fix it to the straightedge at the scribed marks.	Cord must have a sufficient length to extend until the surface of the half-landing.
5. Put the straightedge on the surface of the main top landing in the area of the wall string.	
6. Support the straightedge by a batten to be held perpendicularly and move the straightedge towards the half-landing.	Saw a notch into the upper end of the batten or nail a projecting bearing block onto either wide side of the batten so that the straightedge will not slip off the cross-grained end of the supporting batten. Hold the batten perpendicularly and move it carefully together with the straightedge. Make sure that

	the straightedge is not released, otherwise danger of accidents! The plumb cord must not contact the front edge of the half-landing.
7. Put the water level on the straightedge and level it.	Check the water level for accuracy first.
8. Put the perpendicular batten to the half-landing and scribe-mark the surface of the landing.	Identify the scribed mark with index "W" so that mix-up will be avoided when entering the dimensions into the hand-sketch!
9. Scribe the front edge of the main top landing on the straightedge.	Don't forget index "W"!
10. Wait until the pendulum movement of the hanging plumb stopped and measure the difference between the plumb cord and front edge of the half-landing.	Add up the gauge size scribed on the straightedge and the difference and enter into the plan view of the hand-sketch as flight length.
11. Move the supported straightedge towards the outer string and repeat WORKING STEPS 7. to 10. above in the area of the outer string!	Identify scribed marks on straightedge and batten with index "F"!
12. Retract straightedge with supporting batten towards main landing.	Make sure that the straightedge is not tilted or released!
13. Measure the scribed sizes on the batten and enter into hand-sketch.	Mind indexes "W" and "F"! Write into the sectional view as flight height between half-landing and main top landing.
14. Take a longer batten and put it to the front edges of the two main landings. Scribe-mark the surfaces of the landings.	Hold the batten perpendicularly! Apply the batten in the areas of the wall string and outer string.
15. Remove the batten and measure the size between the scribed marks, write into hand-sketch.	Write into sectional view as floor-to-floor height.
16. Check the landings for horizontal position.	Write any deviations into hand-sketch with "+" or "-".
17. Check the stairwell width, contact the wall with the batten and scribe inner edge.	Write stairwell width into hand-sketch.
18. Find out the stair flight length and stairwell width from the hand-sketch.	Base on determined angle.
19. Compare the dimensions taken off the stairwell with those in the drawing.	Stairs are to be built to the dimensions of the stairwell!

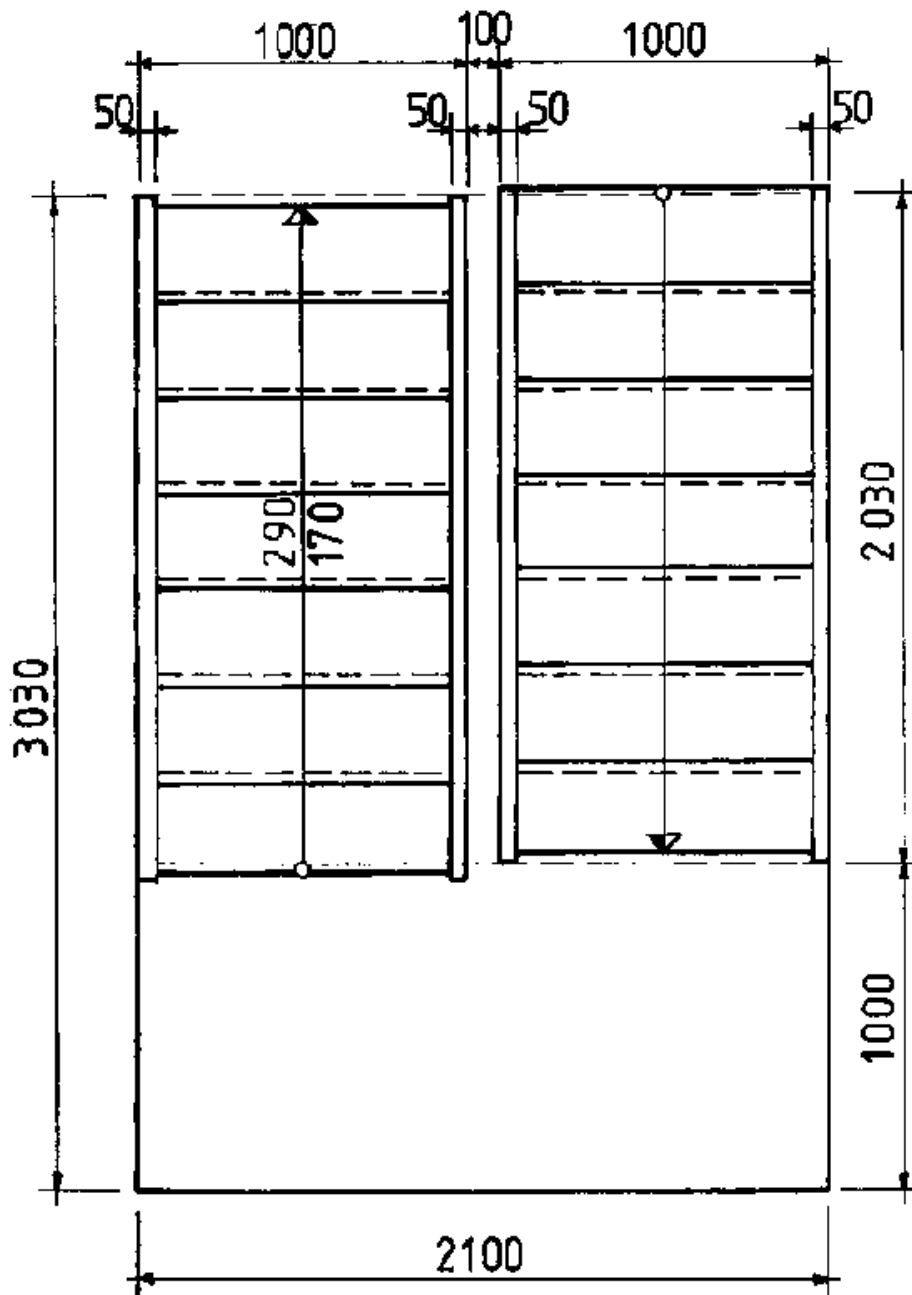

				8.1
IBE	Taking off Dimensions at the Stairwell			3608

Taking off Dimensions at the Stairwell

Instruction Example 8.2.: Determination for the Ratio of Rise and Tread

The dimensions given below have been taken off the stairwell and entered into the hand-sketch.

Details of the stairs to be built in:

- straight stairs with two branches of flights, mortised
- string thickness: 50 mm
- riser thickness: 15 mm
- floor thickness main landing: 24 mm

-

$$m = \frac{290}{170}, n_s = 8$$

Auxiliary accessories

Paper, pencil, slide rule or calculator/computer

Necessary previous knowledge

Fundamental arithmetics: adding, subtracting, dividing, multiplying

Explanations to the working drawing

- (1) main top landing
- (2) main bottom landing
- (3) half-landing
- (4) upper edge of bare ceiling

Sequence of operations	Comments
1. Sequence stair height for one branch of flights.	Divide the measured floor-to-floor height by two.
$L_h = \frac{2736 \text{ mm}}{2} \quad L_h = 1368 \text{ mm}$	
2. Determine the height of rise.	
$s = \frac{L_h}{n_s} \quad s = \frac{1368 \text{ mm}}{8} \quad s = 171 \text{ mm}$	
3. Check the flight length.	Start from the size $n_a \cdot a = L$ and compare with the size at the stairwell (2090 mm).
$L = n_a \cdot a$ $L = 7 \cdot 290 \text{ mm} \quad L = 2030 \text{ mm}$	The difference of 60 mm is to be compensated at the top landing connection!
4. Check the half-landing height. $Gh + d_1 - d_2 = Lh!$ $1410 \text{ mm} + 24 \text{ mm} - 40 \text{ mm} = 1394 \text{ mm} \quad ? \quad 1368 \text{ mm}$	Check from the main top landing. $L_h = 1368 \text{ mm}!$ Half-landing is to be raised!

5. Find out the difference.
 $1394 \text{ mm} - 1368 \text{ mm} = 26 \text{ mm}$

Half-landing is to be raised by 26 mm. Half-landing is not removed but 26 mm thick boards are put on before the floor is constructed!

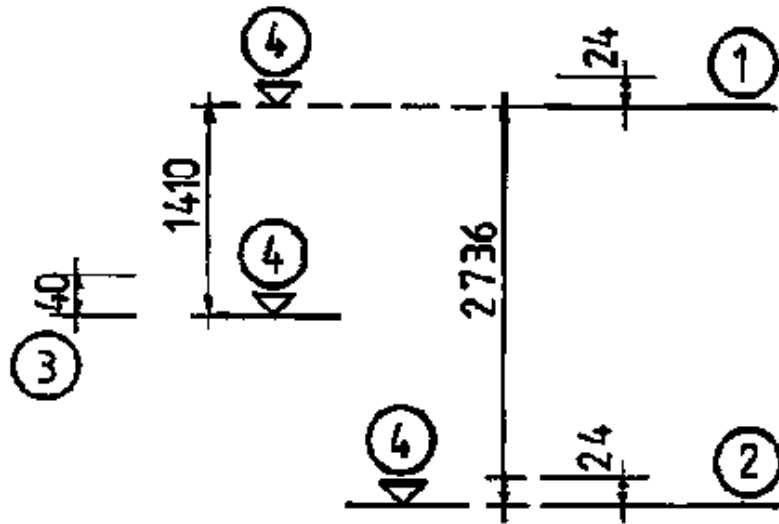
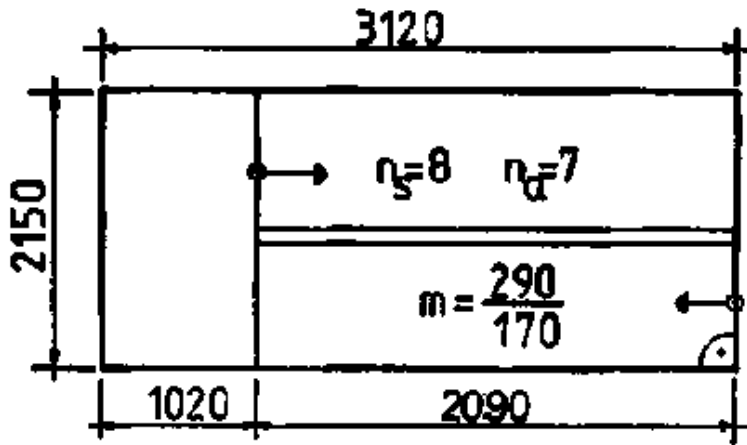

			8.2
IBE	Determination of the Ratio of Rise and Tread		3608

Determination of the Ratio of Rise and Tread

Instruction Example 8.3.: Scribing of landing connections

Details assumed to be known:

Stairwell length without landing: 2200 mm

Stairwell height = stair flight height: 1620 mm

$$m = \frac{270}{180}$$

Ratio of rise and tread

Number of rises $n_s = 9$

Step thickness: 35 mm

Riser thickness: 15 mm

False tread: 30 mm

Floor thickness $d_1 = d_2 = 24$ mm

Cross-section of stair-aprons = 140/180 mm²

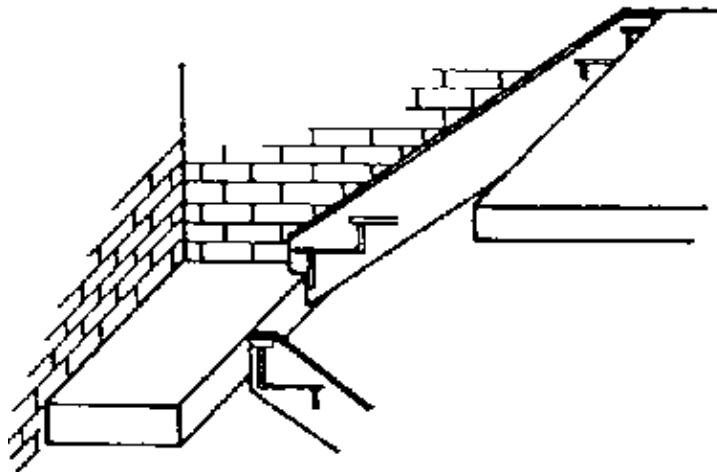

Measuring and testing means

Folding rule, square

Auxiliary accessories

Straight batten for scribing of about 1300 mm length,
Straight batten for scribing step thickness, about 350 mm long and exactly 35 mm wide!

Necessary previous knowledge

Measuring, scribing, angling, testing

Explanations to the working drawing

The landing connections have been drawn on the drawing floor so as to show the surfaces of the stair foot (bottom step) and stair head (head step) on a joint horizontal line.

(1) landing connections drawn on the drawing floor

(2) details of bottom landing

(3) details of stop landing

St – gauge size, hw – string height

Sequence of operations	Comments
1. Draw a horizontal line on the drawing floor.	Draw a thin line over the entire drawing floor.

2. Determine the front edge of the top landing–apron and draw a vertical line downward.	Mind the stair flight direction! Apply the square exactly.
3. Measure–in the floor thickness d_2 .	Measure from 1 downward. Draw the line to 2 only.
4. Measure–in from 1 downward and scribe two heights of rise.	Draw thin lines.
	Draw line 4.1 as long as 1 and parallelly to 1. Lines represent surfaces of the steps.
5. Measure–in and scribe difference (40 mm).	Measure from 2 towards stairwell. Draw a thin line downward parallelly to 2. Line represents top stair string section.
6. Measure–in from 5 and scribe two tread widths.	Draw a thin line parallelly to 5.
7. Measure–in and scribe the step thickness.	Use batten (35 mm width). Apply batten in true alignment–(Batten is still to be used for scribing the stair strings!)
8. Measure–in and scribe the false tread.	Represents the front edge of the steps to be built in.
9. Measure–in and scribe the riser thickness.	Measure from 5 and 6 towards the stair–apron. Draw thin lines, not too long.
10. Draw dash–line over front edges of steps.	Draw very thin dash–line, which is only used for measuring–in the string top.
11. Draw dash–line over lower edges of risers.	Draw very thin dash–line, which is only used for measuring–in the string bottom.
12. Measure–in string top and scribe lower edge of stair string	Make sure it is parallel to 10. Line may be drawn slightly thicker.
13. Measure–in string bottom and scribe lower edge of stair string.	Make sure it is parallel to 11 and 12. The stair string height can be measured between 12 and 13!
14. Determine front edge of bottom stair–landing and drawn a line vertically downward.	Any distance from 2 may be selected. Draw a thin line.
15. Measure–in and scribe floor thickness d_1 .	Measure from 4.1 downward, draw a thin up to 14.
16. Measure–in and scribe false tread.	Draw a thin, short line.
17. Measure–in and scribe tread width.	Measure from 14 towards stair–well.
18. Measure–in and scribe riser thickness.	Measure from 17.
19. Measure–in string top and scribe upper edge of stair string.	Angle of inclination can be found by means of parallel displacement or gauge size (St)! Use the square!
20. Measure–in and scribe lower edge of stair string.	Measure h_w , from 10 downward! Use the square
21. Check again accuracy to size!	Correct, if necessary! 21 is not shown!
22. Limit stair string at bottom landing.	Any size but bigger than or equal to 50 mm!

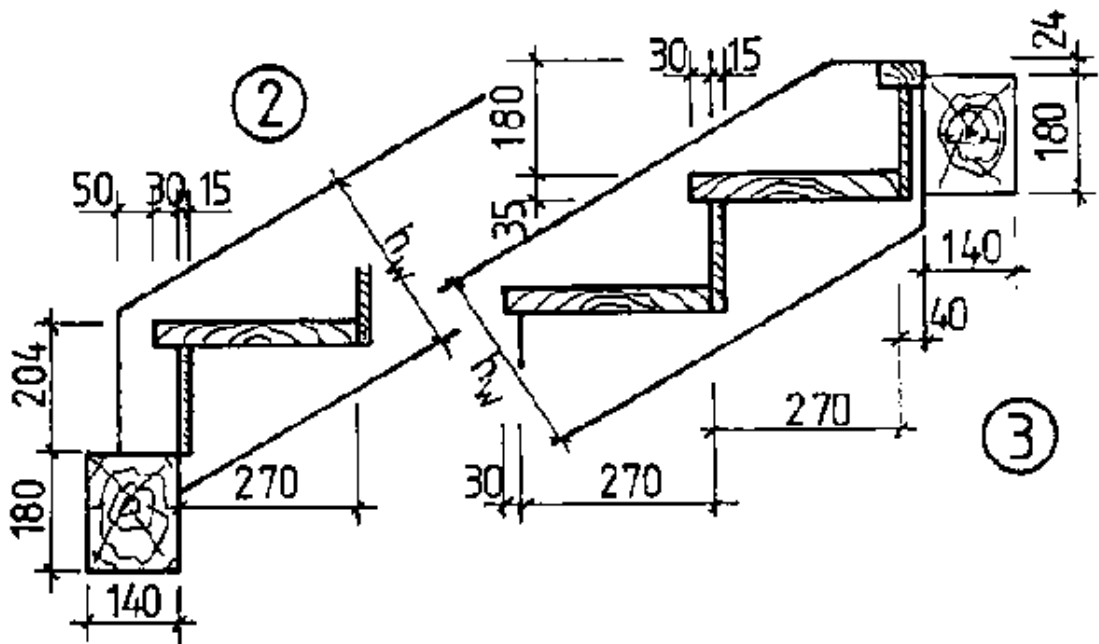
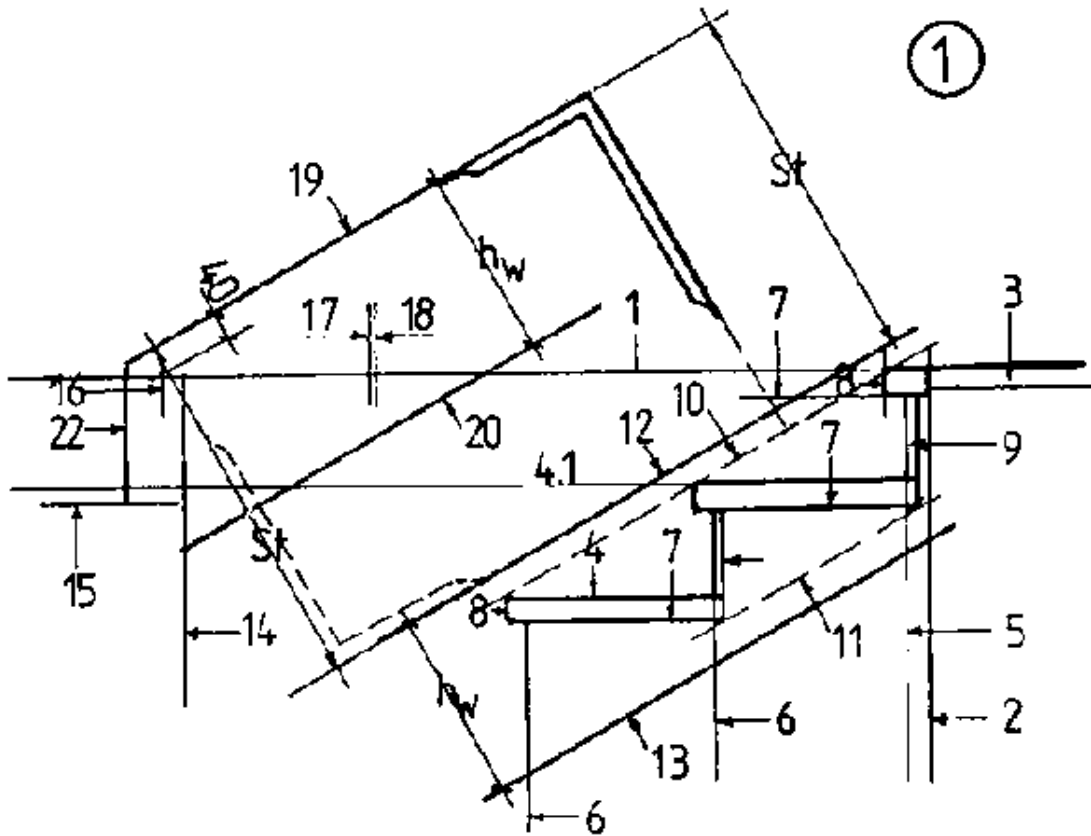

			8.3
IBE	Scribing of Landing Connections		3608

Scribing of Landing Connections

Instruction Example 8.4.: Manufacture of Template and Angular Board

Assumed to be known:

- Height of rise = 180 mm
- Tread width = 270 mm
- String bottom = 40 mm
- False tread = 30 mm

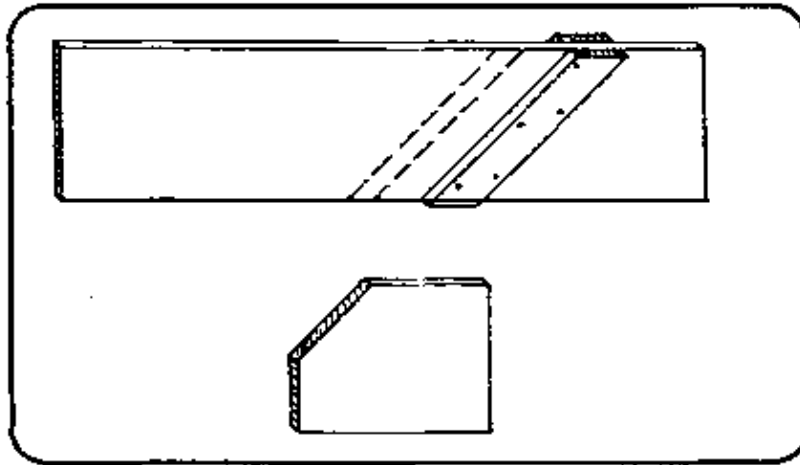

Hand tools

Hammer, jack plane

Measuring and testing means

Folding rule, square

Auxiliary accessories

Pencil, 50 mm long nails board, about 700 mm long, exactly 180 mm wide, 20 mm thick, batten, about 40 mm wide, 450 mm long, 20 mm thick, piece of board, 300 mm long, 200 mm wide, 20 mm thick

Necessary previous knowledge

Measuring, angling, scribing, sawing, manual planing, nailing

Explanations to the working drawing

(1) template for steps

(2) angular board for risers

1 batten, 2 board

b – any size, **u** – false tread, **a** – tread width,
VT – marking, **VS** – front edge of riser, **HS** – rear edge of riser, **s** – height of rise

Sequence of operations	Comments
1. Saw wide board to approximate length.	Scribe the angle.

2. Plane the board to exact width. (Width = height of rise)	Use the jack plane. Make sure parallelism!
3. Measure any size, mark and identify with "VT" marking.	Make short scribe-marking. VT = front edge of step.
4. Measure false tread (u) from "VT" marking, mark and transfer to bottom side of board.	Use the square!
5. Measure one tread width (a) from "u" mark, mark and scribe front edge of riser (VS).	Make short scribe-marking. Use the square..
6. Measure riser thickness from "VS" marking, mark, scribe and identify with "HS" rear edge of riser.	Make short scribe-marking. Use the square.
7. Draw a diagonal line from "VS" to "u".	Draw a thin dash-line. Apply square-leg exactly! (Dash-line represents stair flight inclination!) If the stair flight inclination is wrong, the stair string will not fit into the stairwell!
8. Draw a second line from "HS" in parallel with the drawn dash-line.	Ensure parallelism!
9. Measure-in and mark string bottom square with second dash-line drawn and draw thin line parallelly with dash-line; identify line with "UkW" marking.	Drawn line represents lower edge of stair string.
10. Nail a batten flush with the "UkW" line.	Plane the batten! Any width – approx. 40 mm.
11. Produce angular board.	Board length exactly $u + a$. Width bigger than s. Angular cuts at both sides.
12. Check the sizes of the template and angular board.	Correct, if necessary.

- Step thickness = 35 mm
- Riser thickness = 15 mm
- False tread = 30 mm

- $n_s = 9$,

$$m = \frac{270}{180}$$

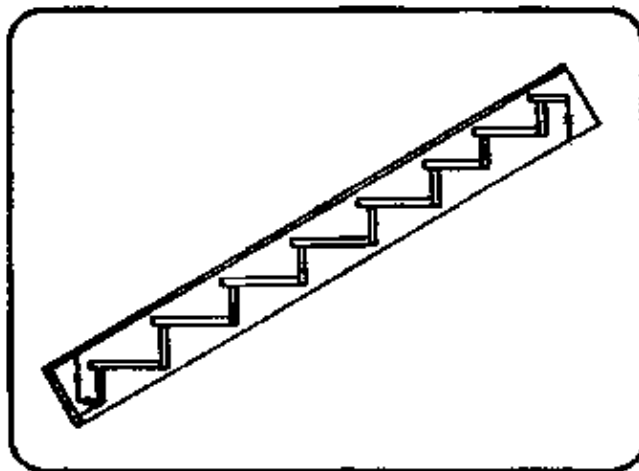

Hand tools

Hammer, hand saw, pad saw, ground plane, mortise chisels 12 mm and 24 mm, planing chisel, beating wood

Measuring and testing means

Folding rule, square, sliding T-bevel

Auxiliary accessories

Template, angular board, 35 mm wide and 400 mm long batten, abrasive paper

Necessary previous knowledge

Measuring, scribing, angling, mortising, cleaning, sanding, sawing

Explanations to the working drawing

- (1) scribing of the wall string
- (2) bottom landing connection
- (3) top landing connection

Sequence of operations		Comments
1. Determine stair string length		
Required: L_w , $L_w = (n_s + 0.5) c$		
Known:	$n_s = 9$	
	$c = 325 \text{ mm}$	Measure from drawing floor.
	$L_w = (9 + 0.5) 325$	

	mm	
	$L_w = 3087.5$ mm	
	L_w selected = 3150 mm	
2. Inspect string wood for grain flow and branch knots and identify with "F" or "W" marking.		"F" for outer string, use better surface. "W" for wall string.
3. Measure the size for the bottom step from the bottom landing connection and measure-in and mark on the string identified with "W" marking.		In this example approx. 500 mm
4. Set template to marking and scribe lower edge of step.		Set exactly! Scribe from "VT" to bottom edge of string.
5. Scribe step thickness.		Do not displace the template! Put on batten (35 mm wide) and scribe from "VT" to "Hs".
6. Scribe front edge of riser and front edge of step.		Do not displace the template!
		Remove the batten and set the angular board ("VT" and "VS" must be flush). At "VS" scribe only between top and bottom surfaces of stop. At "VS" scribe over the entire length.
7. Scribe rear edge of riser.		Do not displace the template! Move angular board towards "HS" and scribe thin line over entire length. Set template and angular board exactly!
8. Scribe surface of bottom landing.		Move template towards surface of bottom step and scribe thin line at bottom side of template. Scribe over entire string height.
9. Scribe next step and riser.		Move template towards top landing connection until bottom side of template is flush with bottom surface of bottom step! Scribe at top side of template. Repeat working steps 5., 6. and 7. Set template exactly! (Bottom edge of pencil scribe-mark must be exactly flush with bottom side of template!)
10. Check scribed step for accuracy to size.		In case of deviations, re-work template and/or angular board.
11. Scribe remaining steps and risers.		Follow the sequence of operations! Always scribe bottom surface of step until bottom edge of string!
12. Put wall string on outer string and transfer bottom edges of steps.		Bottom sides of strings must be flush. Use the square. Lines should not be scribed too thick.
13. Scribe the outer string.		Same procedure as for wall string. Always set top side of template to transferred angular scribe-markings to achieve exact mirror-image!
14. Scribe bottom landing connection.		Take off dimensions from drawing floor. Ensure parallelism with rise and tread!
15. Check again string section and mark with cross.		Draw lines a little thicker. Cross means section.
16. Scribe top landing connection.		Take off dimensions from drawing floor. Ensure parallelism with rise and tread!
17. Check again string section and mark with cross.		Draw lines of section a little thicker.

18. Prepare the stair strings.	Put strings on solid support to avoid springiness when mortising. Avoid tilting-up of the strings during mortising, otherwise danger of accidents!
19. Mortise all step holes of one string.	Do not put mortise chisel on pencil scribe-marking. Consider grain flow when mortising.
20. Check mortising depth of holes.	Leave about 1 mm on the hole bottom. Exact depth is achieved by means of ground plane.
21. Mortise the holes for the risers.	Use pad saw at opening for step. Use piece of wood so that the teeth of the pad saw cannot slip off. Consider grain flow!
22. Check mortising depth.	
23. Clean holes for steps and risers.	Re-chisel sensitively. Half of pencil scribe-marking must be left visible.
24. Slightly re-chisel edges of hole bottoms with mortise chisel.	Re-chisel sensitively, not too deep.
25. Plane hole bottoms for steps and risers to exact depth.	Use ground plane. Do not plane against grain flow. Guide ground plane sensitively to avoid damage to the hole edges and comers!
26. Saw-out top and bottom landing connections.	Ensure right-angle cutting.
27. Smooth strings with abrasive paper.	Use fine-grain abrasive paper. Do not sand-off hole edges! No scribe-markings must be left visible.

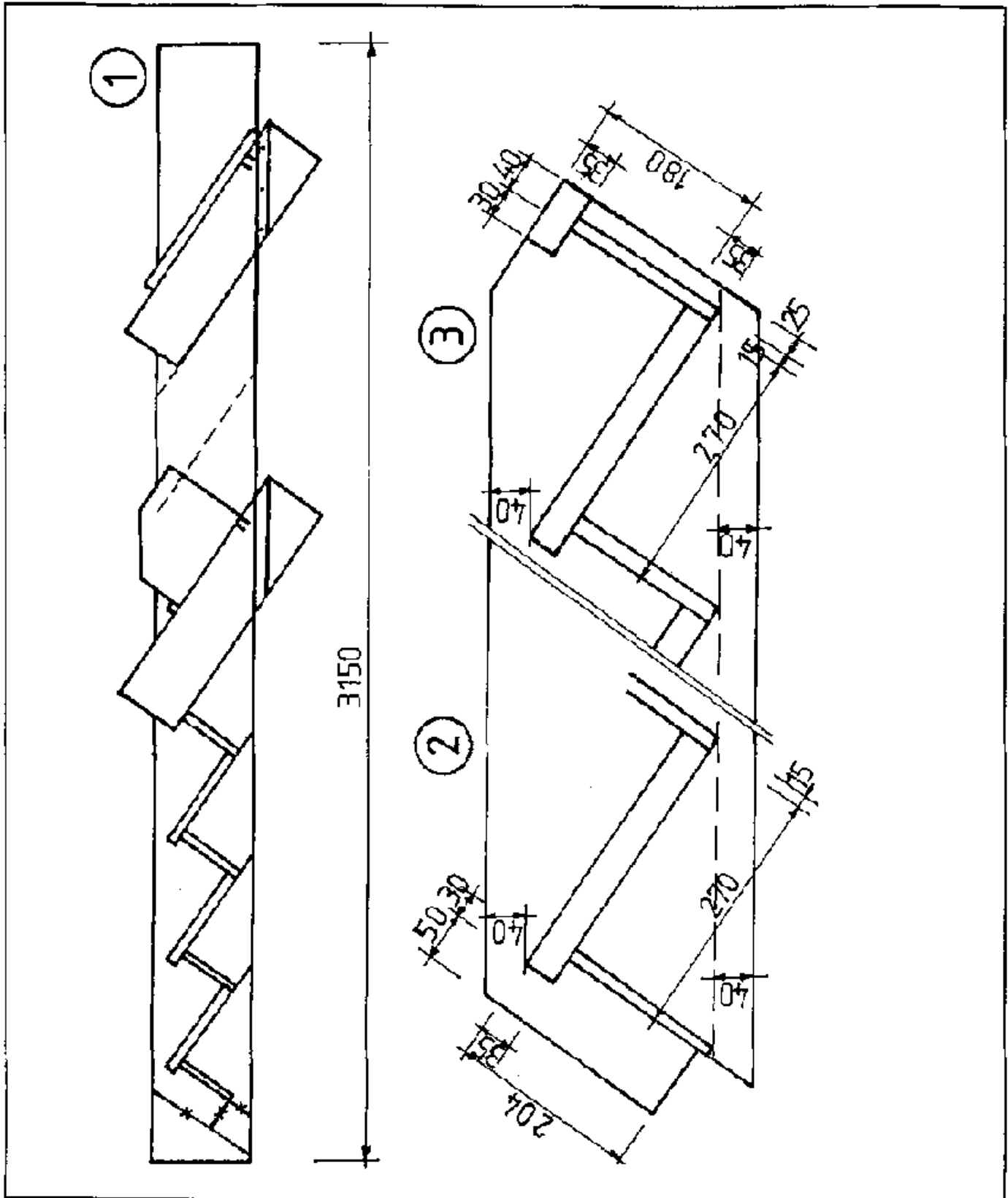

			8.5
IBE	Scribing and Preparing the Stair Strings		3608

Scribing and Preparing the Stair Strings

Instruction Example 8.6.: Manufacture of Steps and Risers

The wood for the steps and risers is prepared with exact thickness, glued to approximate width and planed on three sides.

Assumed to be known:

- Step thickness = 35 mm
- Riser thickness = 15 mm
- False tread = 30 mm

- $n_s = 8$,

$$m = \frac{270}{180}$$

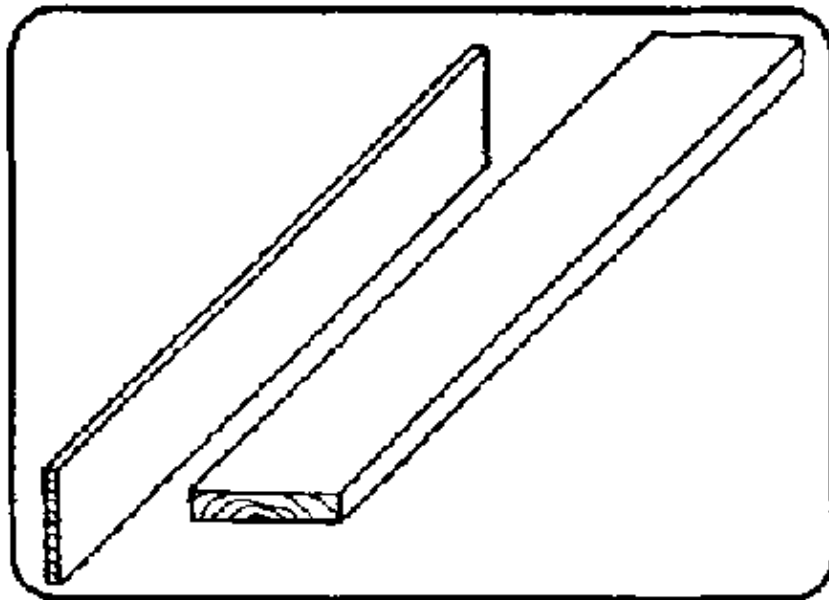

Hand tools

Hammer, hand saw, planing chisel, jack plane

Measuring and testing means

Folding rule, square

Auxiliary accessories

Pencil, straight batten, about 1100 mm long, 50 mm wide and 24 mm thick, abrasive paper

Necessary previous knowledge

Measuring, scribing, angling, smoothing (sanding), sawing

Sequence of operations	Comments

1. Inspect wood for steps for growth and branch knots and number it.	Number on cross-grain end. Grade surface quality starting with better surface from bottom step.
2. Determine step length.	Length = clear width of stair flight + two hole depths.
3. Put one step on workbench, scribe length and four right angles.	Set square exactly! Step is to be used as template for the remaining steps!
4. Scribe step width.	Ensure parallelism! Width = a + u!
5. Saw-out scribed step.	Cross-cut exactly on scribed lines. Longitudinal cut should be little wider than scribed lines (is to be planed!)
6. Plane step to scribed width.	Use jack plane. Ensure parallelism!
7. Put sawn-out and planed step as template on the remaining steps to be produced, one by one, and scribe-mark to such step.	Front edge of template to be put-on flush. Use sharp pencil. Attention: Head step must have less width!
8. Saw-out scribed steps.	Refer working step 5.!
9. Plane steps to exact width.	Use jack plane.
10. Manufacture head step.	Same length as the other steps. Width to be measured from top landing connection.
11. Smooth steps with abrasive paper.	Do not sand-off any chamfers! Use fine-grain abrasive paper.
12. Determine riser length.	5 mm shorter than step.
13. Put one riser on workbench, scribe length determined and four right angles.	Set square exactly. Riser is to be used as template!
14. Cut riser to length.	Saw exactly on scribed lines.
15. Manufacture remaining risers to such template.	Template to be set flush!
16. Smooth risers with abrasive paper.	Do not sand-off any chamfers. Use fine-grain abrasive paper.

Instruction Example 8.7.: Assembly of the Stair Flight

The prefabricated stair strings, steps and risers are to be assembled to a stair flight.

Additional material required:

Screw rods, washers, nuts, rosettes and wood screws.

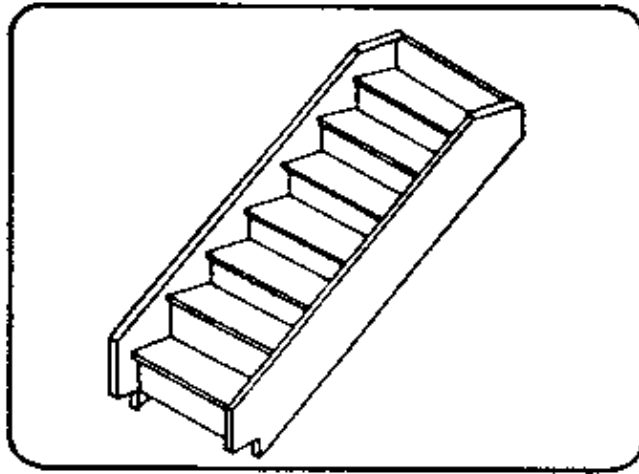

Hand tools

Plane, hammer, wrench (opening 13 mm), bit brace with 8 mm dia. bit, gimlet, screw driver, iron saw

Measuring and testing means

Folding rule, square

Auxiliary accessories

Wooden supports, wooden sections (several lengths from 500 mm to 1000 mm), nails of 50 mm shank length

Necessary previous knowledge

Drilling (boring), nailing, chamfering, (metal) sawing, screwing, sanding

Sequence of operations	Comments
1. Put one stair string on the other one, flush with each other, and scribe the holes.	Ensure flushing landing connection. Use wooden supports. String must not be springy.
2. Drill the holes.	Drill vertically to the string face.
3. Remove the wall string and put the screw rods into the outer string.	Put the screw rods in from the correct side.
4. Slightly chamfer the steps at the cross-grain end.	Use the plane.
5. Insert the steps in the mortised holes and slightly beat them in.	Put on a wooden section!
6. Slightly chamfer the risers at the cross-grain end.	Use the plane.
7. Insert the risers in the mortised holes and slightly beat them in.	Use a wooden section.
8. Put-on the wall string and enter the steps and risers into it.	Put the screw rods in first! Start from one landing connection.
9. Attach the washers and slightly screw-on the nuts.	Do not tighten the nuts too much.
10. Beat-in the wall string and re-tighten the nuts at the same time.	Use a wooden section. Do not apply force when re-tightening the nuts.
11. Check the wall string for tight fit.	Put-on a longer wooden section and beat-in the string. Check the clear size of the stair flight.

12. Finally tighten the nuts.	Do not tighten forcefully.
13. Saw-off any excessive thread length of the screw rods.	
14. Nail risers to rear edge of steps.	Nails must not penetrate through the surface of the steps.
15. Screw-on the rosettes.	
16. Smooth the stair flight with abrasive paper.	No pencil markings must be left visible!

Stairmaking – Course: Timberwork techniques. Trainees' handbook of lessons

Table of Contents

<u>Stairmaking – Course: Timberwork techniques. Trainees' handbook of lessons</u>	1
1. <u>Purpose of Stairs</u>	1
2. <u>Types of Straight Wooden Stairs</u>	3
3. <u>Stair components</u>	8
4. <u>Taking off Dimensions at the Stairwell</u>	20
5. <u>Calculations for Stairmaking</u>	26
6. <u>Assembly of the Stair Components</u>	31
<u>List of symbols and technical terms used in stairmaking</u>	34

Stairmaking – Course: Timberwork techniques. Trainees' handbook of lessons

Institut für berufliche Entwicklung e.V.
Berlin

Original title:
Arbeitsmaterial für den Lernenden
"Herstellen von Treppen"

Author: Rolf Becher

First Edition © IBE

Institut für berufliche Entwicklung e.V.
Parkstraße 23
13187 Berlin

Order No.: 93-35-3608/2

1. Purpose of Stairs

Stairs (staircases) are sets of steps having more than three rises and a flight line under an angle of inclination of α (?).

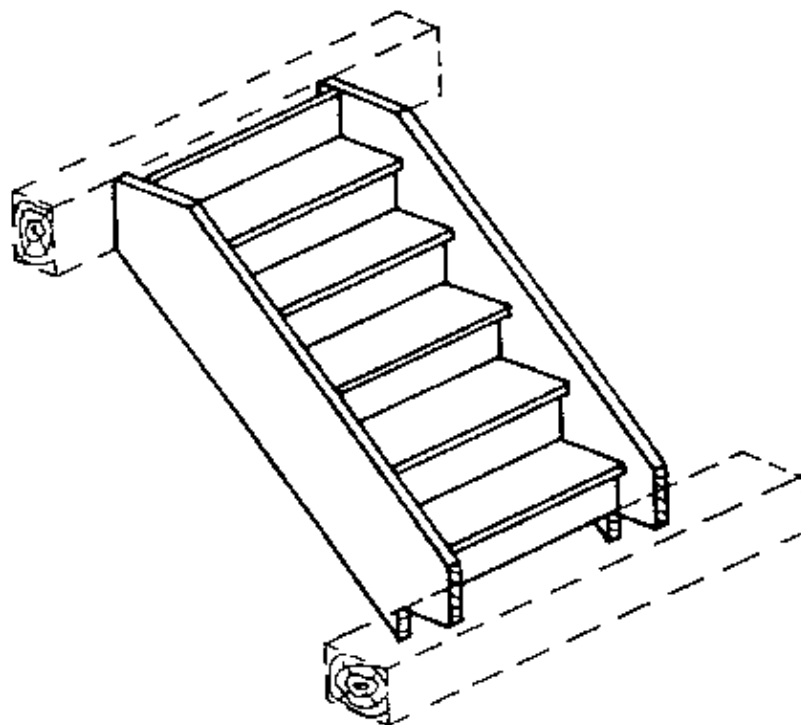

Figure 1 – Single-branch flight of mortised wooden stairs

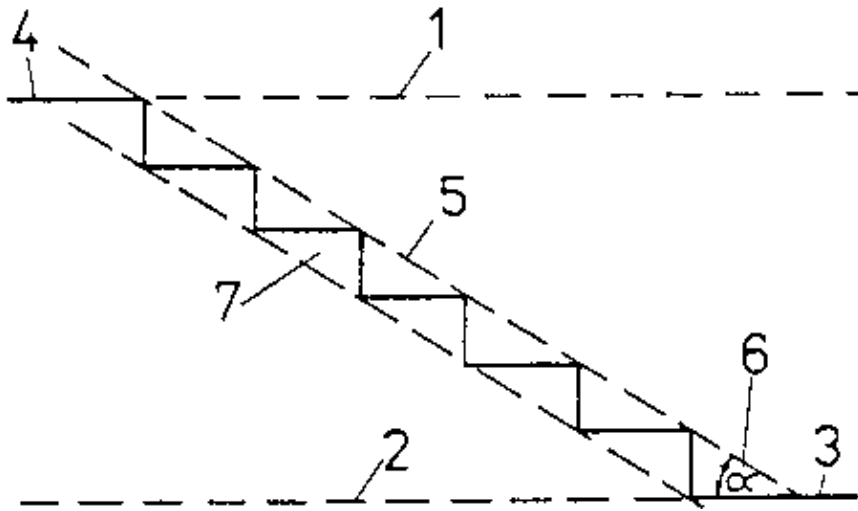

Figure 2 – Features of a staircase (set of steps) 1 upper level, 2 lower level, 3 surface – bottom landing, 4 surface – top landing, 5 stair flight line, 6 angle of inclination of the stair flight, 7 stair flight (inclined pan of the stairs)

A set of steps consists of a bottom stair landing, a top stair landing and the flight of stairs.

The angle of inclination (?) of the flight line results from the ratio of flight height and flight length (see Fig. 10).

Stairs are needed for convenient and safe going from one level to another one. They are also necessary for evacuating people in emergency cases.

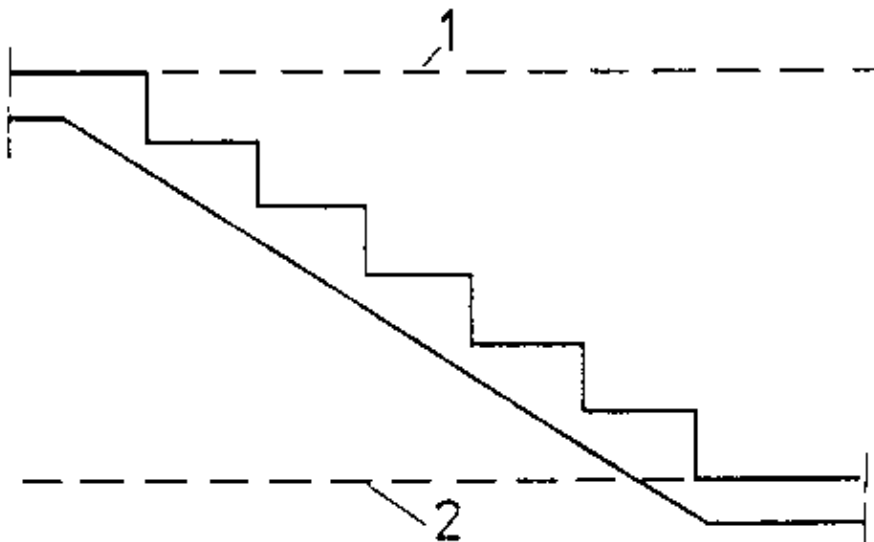

Figure 3 – Representation of the two different levels of a staircase – 1 upper level, 2 lower level

A wooden staircase consists of the bottom and top stair landings, the two strings (or string boards) and a number of successive steps. Stair railings provide lateral protection against falling down.

Soft wood may be used for the strings.

The steps (treads) must be made of hard wood because they are subject to heavy wear.

The risers are not subject to wear and may be made of soft wood. In the interest of an attractive appearance of the staircase, well-veined hard wood should be used only.

What does the term "stairs" (or "staircase") mean?

Why should the steps (treads) be made of hard wood?

2. Types of Straight Wooden Stairs

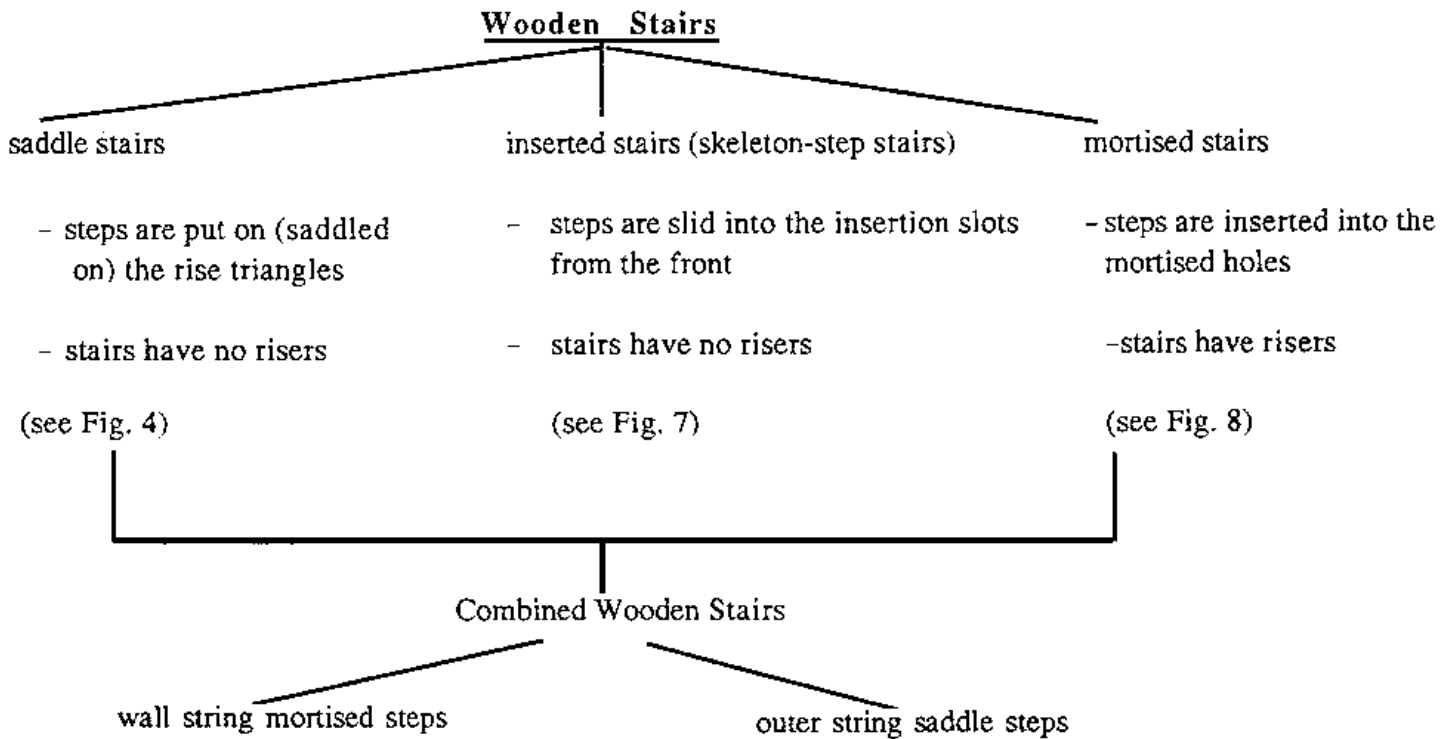

Table 1: (see Fig. 6) Such stairs may be designed with risers or without risers

Saddle stairs

Saddle stairs are staircases where the steps are set on the sawn-out or attached rise triangles or on bearing blocks fitted at the strings.

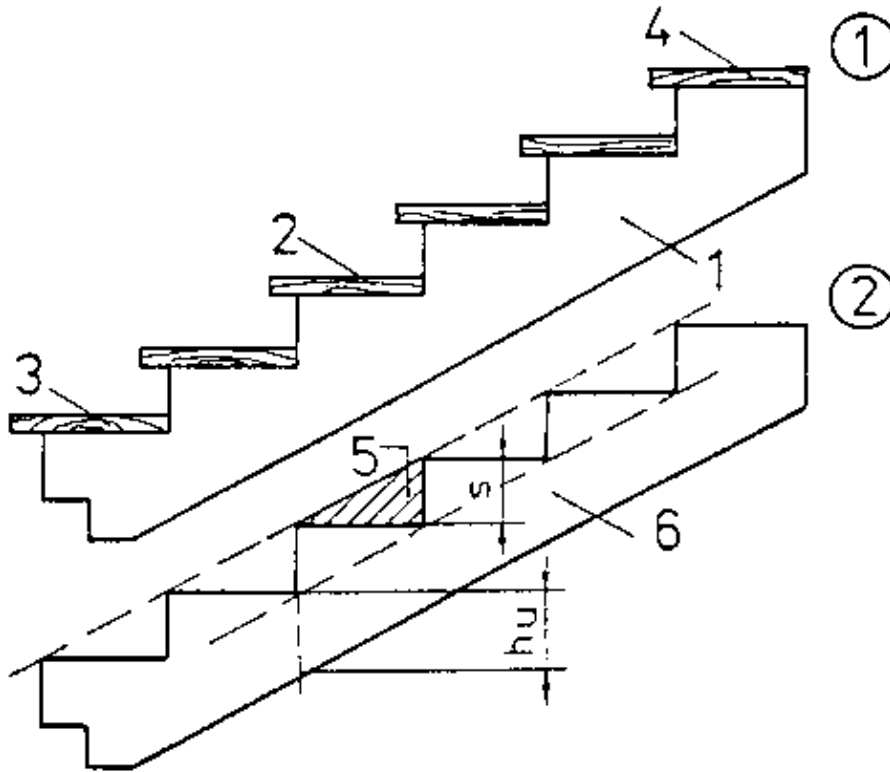

Figure 4 – Saddle stairs – (1) sectional view of saddle stairs 1 stair string, 2 step, 3 stair foot (bottom step), 4 stair head (head step) – (2) sawn-out stair string s – height of rise, h_u – height of string bottom, 5 sawn-out rise triangle, 6 string bottom

For stairs with sawn-out or attached rise triangles the string bottom must have a sufficient height. The height of the string bottom is calculated by means of the following formula:

$$h_u = 40 \text{ mm} \left(\frac{s}{W_d} + 2 \right) \quad (\text{Formula 1})$$

h_u = height of the string bottom

s = height of rise

W_d = string thickness

Table 2:

Perpendicular height (h_u) of the string bottom for wooden saddle stairs

Stair flight width	Stair string thickness	Perpendicular height of the string bottom
B	W_d	h_u
in mm	in mm	in mm
up to 1200	60	
from 1200 up to 1250	65	
from 1250 up to 1500	70	$h_u = 40 \text{ mm} \left(\frac{s}{W_d} + 2 \right)$
from 1500 up to 1750	75	
from 1750 up to 2000	80	

Saddle stairs can be designed as pure saddle stairs or as combined saddle stairs. There are three types of pure saddle stairs.

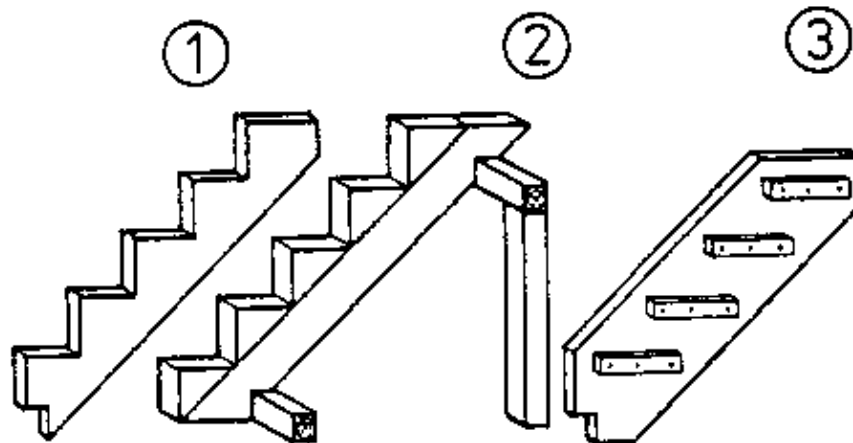

Figure 5 – Types of saddle stairs

- (1) stairs with sawn-out rise triangles
- (2) stairs with attached rise triangles
- (3) stairs with bearing blocks nailed onto the strings

Stairs with attached rise triangles and stairs with bearing blocks fitted at the strings are mainly built as temporary stairs. Such stairs are used temporarily only, such as in the preparation of a building site as access to site accommodations, as access to working platforms, etc.

They are removed and disassembled later. Thus the material can be reclaimed and reused.

When the sawn-out rise triangles of the strings are cut-off from the string bottom, such wood can be reused as posts (see Fig. 4/2).

Similarly the squared timber of stairs with attached rise triangles can be reused.

Combined saddle stairs can be built into apartments or smaller dwelling houses as floor-to-floor staircase.

Such stairs are not removed but remain permanently in place until they are worn out.

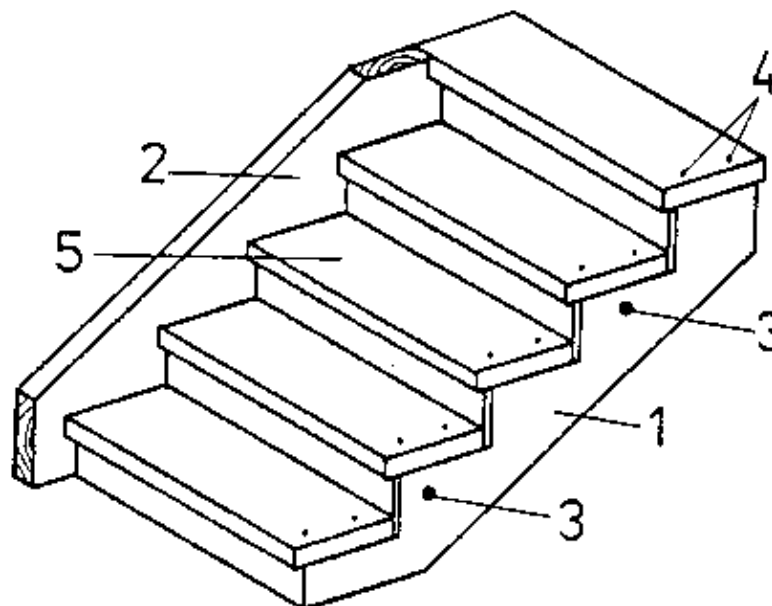
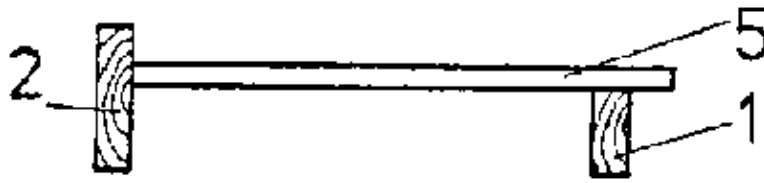

Figure 6 Combined saddle stairs – 1 sawn-out stair string (outer string), 2 mortised stair string (wall string), 3 screw rod with rosette, 4 wood screw (countersunk head), 5 step (mortised at left-hand side, saddled on right-hand side)



The steps (treads) are mortised into the wall string and set on the outer string.

Such stairs may also be designed with risers.

The visible end-grained wood of the outer string is to be lagged by veneering.

What are "temporary stairs"?

Inserted stairs (skeleton-step stairs)

Inserted stairs (or skeleton-step stairs) do not have any risers. Therefore, they should be used as access to ancillary rooms or be built into ancillary rooms only, such as stairs to or in the attics.

The steps (treads) of such stairs are inserted (slid) into the mortised step supports from the front.

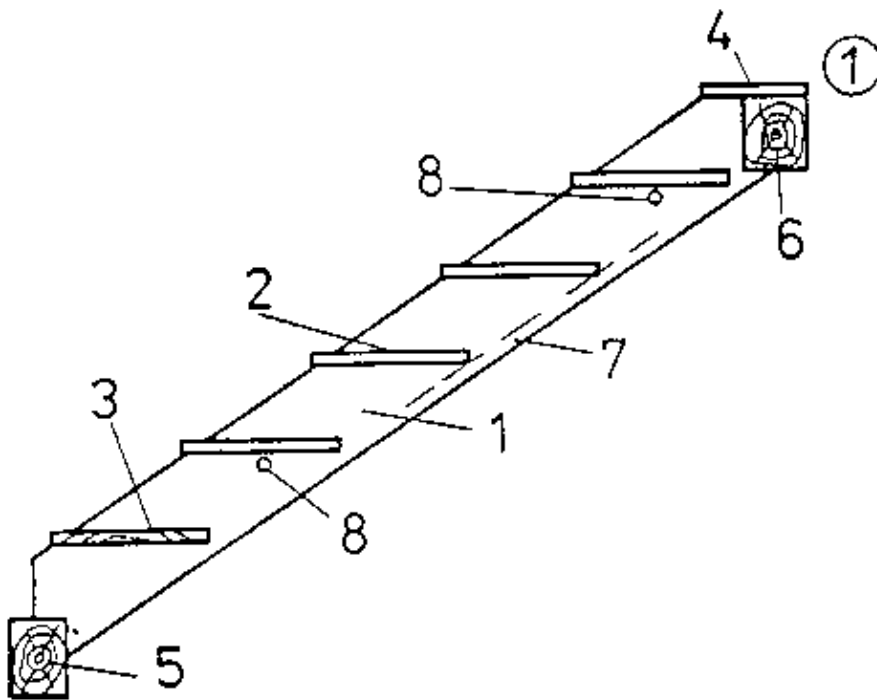
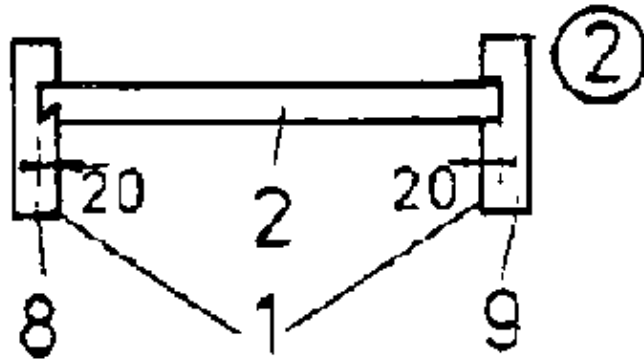

Figure 7 – Inserted stairs (skeleton-step stairs) – (1) sectional view of inserted stairs – 1 stair string, 2 step, 3 stair foot (bottom step), 4 stair head (head step), 5 lower (bottom) stair-apron, 6 upper (top) stair-apron, 7 string bottom, screw rod – (2) (3) Insertion (sliding-in) of the step into the insertion slot 1 stair string with mortised insertion slots, 2 step, 3 insertion slot, 4 line of inclination of the stair flight. 5 step with facing board to cover the insertion slot, 6 lower (bottom) stair-apron, 7 drilled hole for the screw rod, 8 stair string with arris for insertion, 9 stair string without arris for insertion

The steps may be designed with or without arris for insertion. In order to cover the mortise, the front of the step can be provided with a facing board (see Fig. 7/2).

The string height depends on the angle of inclination of the flight and can be measured from the drawing floor (Fig. 16).



However, it should not be less than 260 mm.

If no arris is applied for insertion, the stair strings must be drawn together by means of screw rods to fix the steps.

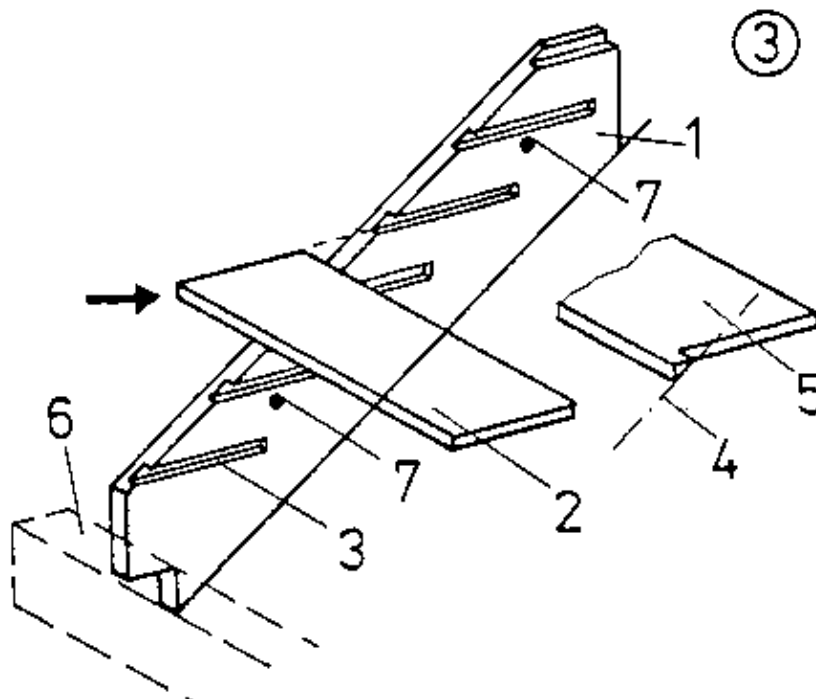

Screw rods are round metal rods with threads at both ends and with nuts.

The nuts at the outer string can be covered by rosettes. Screw rods are also recommended for stairs with arris for insertion.

What are "inserted stairs" (skeleton-step stairs)?

Mortised stairs

Mortised stairs (stairs with mortised treads) have risers. They are typical floor-to-floor staircases in dwelling houses.

The riser serves a double purpose. It supports the step and prevents deflection of the step under load and it also protects the user of the stairs from objects falling down from other flights upstairs. The string height depends on the angle of inclination of the flight and can be measured from the drawing floor. However it should be at least 260 mm.

The step thickness depends on the flight width.

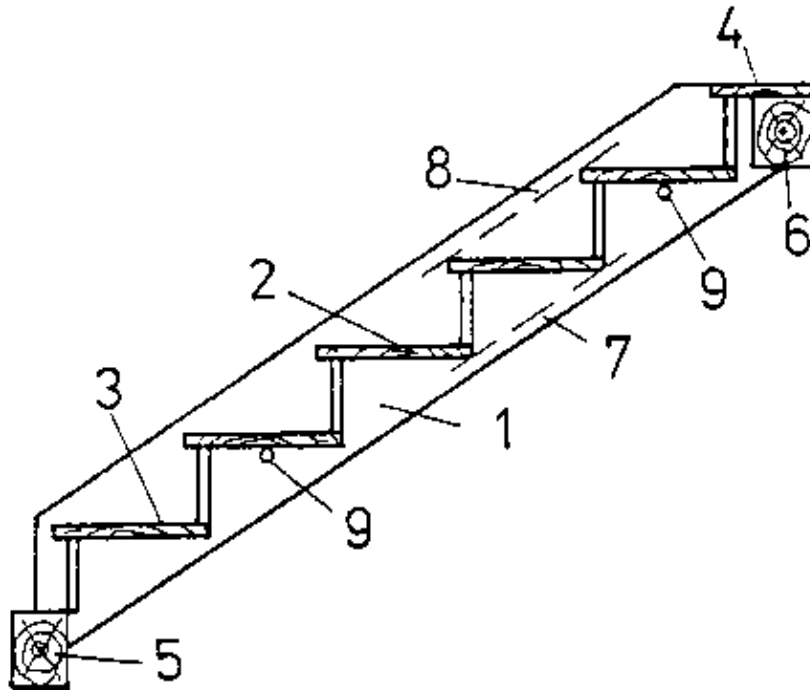

Figure 8 – Sectional view of mortised stairs – 1 stair string, 2 step, 3 stair foot (bottom step), 4 stair head (head step), 5 lower (bottom) stair-apron, 6 upper (top) stair-apron, 7 string bottom, 8 string top, 9 screw rod

Table 3:

Step (tread) thickness of solid wood in planed condition for wooden stairs

Stair flight width	Saddle stairs and inserted stairs with a tread width		Mortised stairs
	up to 240 mm	up to 300 mm	
	in mm	in mm	
up to 800	35	32	30
from 800 up to 1000	40	35	30
from 1000 up to 1300	45	40	35
from 1300 up to 1500	50	45	40

The riser thickness should be within 15 to 20 mm. The strings of mortised stairs should be drawn together by at least two screw rods. The nuts in the outer string can be covered by rosettes.

What types of stairs can be built?

3. Stair components

Tread width

The tread width of a step cannot be chosen at random. It is determined by the average step size of grown-up people.

The average step size to be considered for calculations is 630 mm!

Any new staircase to be built, which is not tied to fixed points like stair-aprons, is calculated to the step size formula.

$$S_m = a + 2s$$

S_m = step size (Formula 2)

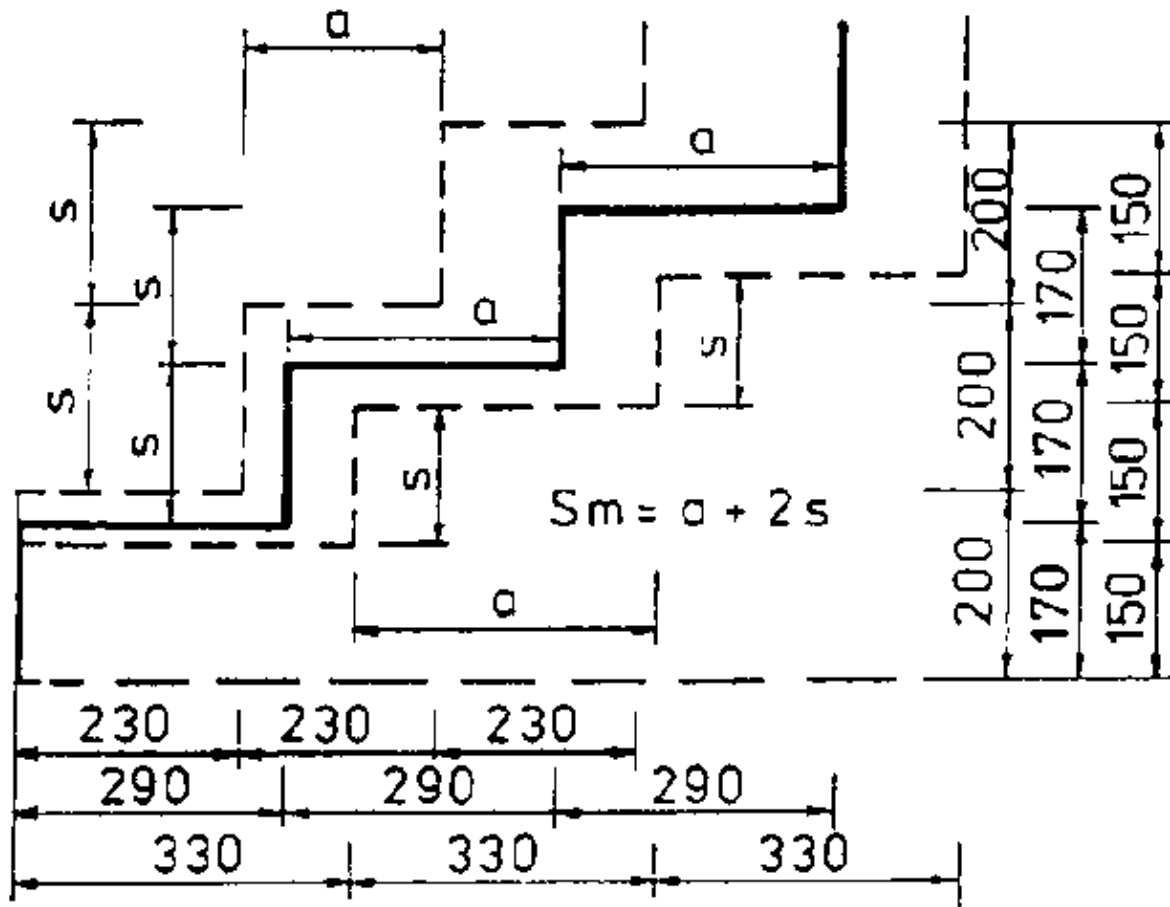

Figure 9 – Representation of the dependence of the height of rise and of the tread width on the step size – a tread width, s height of rise, S_m step size

Since the tread width depends, to a great extent, on the height of rise, the step size of 630 mm can be taken care of. Thus the step size may vary between 615 mm and 645 mm. Stairs built in this ratio of rise and tread are easy to step on.

Height of rise

The height of rise is the vertical distance between the surfaces of the steps (treads).

The height of rise cannot be chosen at random.

For floor-to-floor staircases in dwelling houses it should be between 165 mm and 190 mm.

The height of rise takes priority for the determination of the ratio of rise and tread because the head steps of the flights must be flush with (have the same height as) the surfaces of the stair landings and the heights of rise within one flight must be of the same size.

The height of rise is calculated by means of the following formula:

$$s = \frac{Lh}{n_s}$$

Lh = flight height (Formula 3)

n_s = number of rises

In order to calculate the height of rise for a flight, the number of rises must be known first. The number of rises can be determined by assuming any height of rise between 165 mm and 190 mm and completing the formula by it.

$$n_s = \frac{Lh}{s_g} \quad (\text{Formula 4})$$

sg = height of rise chosen (assumed)

If the result is a decimal fraction, it must be rounded off to bring it up or down to an integer number.

When rounding down, the height of rise will become greater than the one assumed!
When rounding up, the height of rise will become smaller than the one assumed!

Such rounded-off figure is applied to the formula (3) to get the height of rise for the staircase.

The ideal height of rise is 170 mm!

For stairs in ancillary rooms the height of rise may be up to 220 mm.

Ratio of rise and tread

The ratio of rise and tread is expressed by formula (5).

$$m = \frac{a}{s}$$

m = ratio of rise and tread

a = tread

s = height of rise

$$m = \frac{290}{170}$$

The ideal ratio of rise and tread is:

Any staircase must be built to a ratio of rise and tread to be determined in advance.

The height of rise takes priority for the determination of the ratio of rise and tread.

Even if drawings are available for stairs to be built, you should not rely on such drawings only.

Generally, all dimensions for the manufacture of a staircase should be taken from the stairwell and be compared with the drawing.

In most cases, the dimensions taken from the stairwell differ from the dimensions in the drawing. Therefore, the ratio of rise and tread is to be calculated anew for each staircase.

The dimensions taken from the stairwell are binding for the calculation of the ratio of rise and tread!

What is the meaning of "ratio of rise and tread" of a staircase?

Flight line of stairs

The flight line is an imaginary line running over the front edges of the steps in the centre of the stair flight. In the plan view it is represented by an arrow showing the flight direction of the stairs (see Fig. 11).

The ratio of rise and tread is determined at the flight line shown in the plan view.

Flight length of stairs

The flight line shown in the plan view corresponds to the real length of the stair flight.

The flight length of stairs is the horizontal distance between the front edge of the bottom step and the front edge of the head step.

The stair flight is the inclined part of the stairs and consists of a number of treads of equal width.

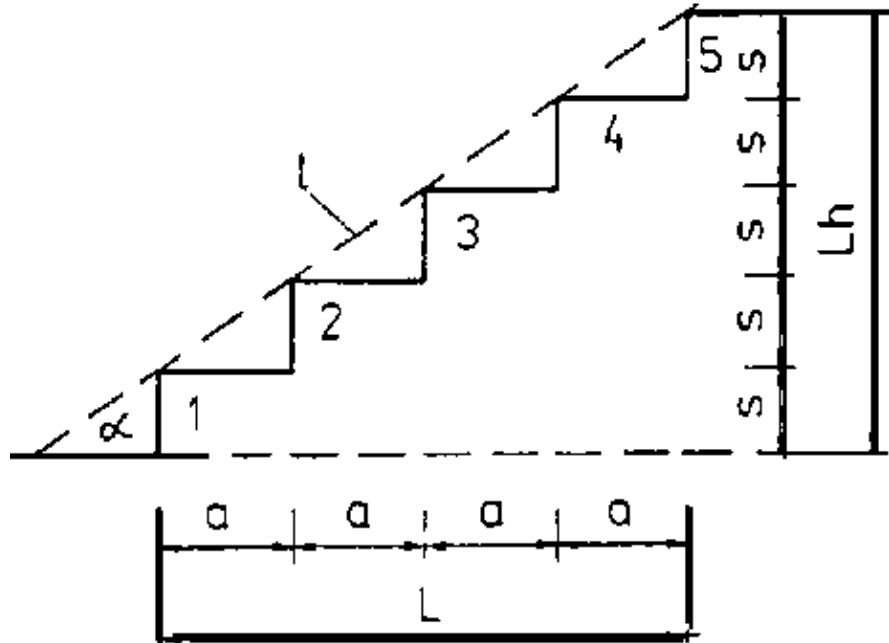

Figure 10 – Connection between stair flight length and stair flight height – **a** tread width, **s** height of rise, **1** stair flight line, – **L** stair flight length, **Lh** stair/light height, **α** angle of inclination of the stair flight 1 – 4 in "L" direction is the number of treads 1 – 5 in "Lh" direction is the number of rises

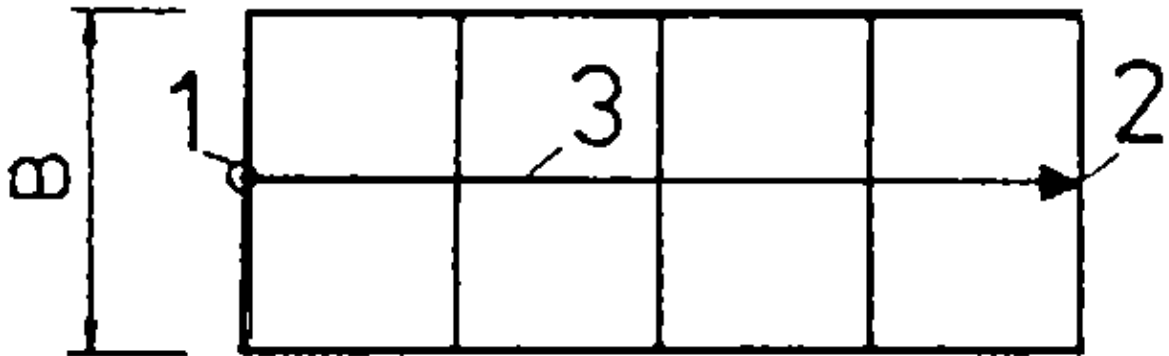

Figure 11 – Layout (plan view) of the stair flight 1 stair foot (bottom step) at the stair flight line, 2 stair head (head step) at the stair flight line, 3 stair flight line, **B** stair flight width

The flight length is calculated to the formula:

$$L = n_a \cdot a$$

L = flight length of stairs (Formula 6)

n_a = number of treads

One flight of stairs should consist of not more than 15 treads. If more than 15 treads are required for a staircase, a landing should be included.

More than 15 treads in one flight of stairs would require much physical effort of the user of such stairs. If the tread width is required for the calculation of the ratio of rise and tread, formula (6) is to be conversed to give the tread width as under:

$$a = \frac{L}{n_a}$$

This formula is required when the flight length is limited by built-in stair-aprons (see Fig. 12).

Flight height of stairs

The flight height of stairs consists of a number of heights of rise of equal size (see Fig. 10).

The flight height of stairs is the vertical distance between the surfaces of the two landings.

In this respect it is important that the distance between the surfaces of the finished floor is to be measured. That means, the construction of the floor must be known!

The flight height of stairs decides how many rises are to be included in a flight of stairs because the height of rise cannot be chosen at random.

The flight height is calculated to the formula:

$$L_h = n_s \cdot s \quad (\text{Formula 8})$$

The flight height of stairs is riot in any case equal to the height between floors.

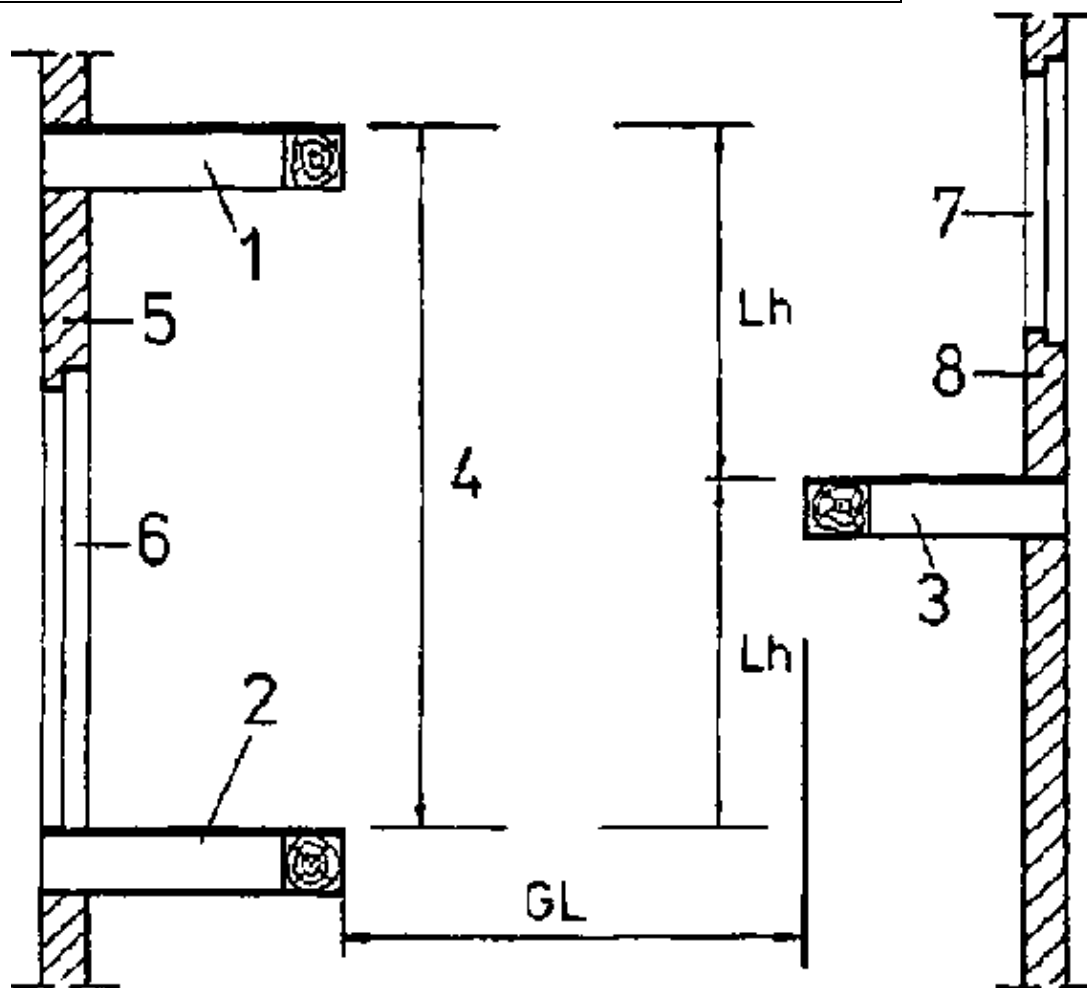

Figure 12 – Connection between floor-to-floor height (height between floors) and the stair flight height – 1 main top landing, 2 main bottom landing, 3 half-landing, 4 floor-to-floor height, 5 staircase (stairwell) wall with access to flat, 6 access to flat (door), 7 staircase window, 8 staircase (stairwell) wall (mostly outer wall),

Lh stair flight height, *GL* stairwell length

The height between floors is the vertical distance between the surfaces of the main landings! In stairmaking it is important to know that each flight of stairs always has one rise more than treads!

$$n_s = n_a + 1 \quad (\text{Formula 9})$$

What is the flight line of stairs important for in stairmaking?

What is the "flight length of stairs"?

What is the "flight height of stairs"?

Landings

Stair landings are resting places for people who, for health or age reasons, have difficulties in climbing stairs. Without landings the flight of stairs would not be accessible!

The length of main landings must correspond to the flight width. Half-landings must have a minimum length of three times the tread width.

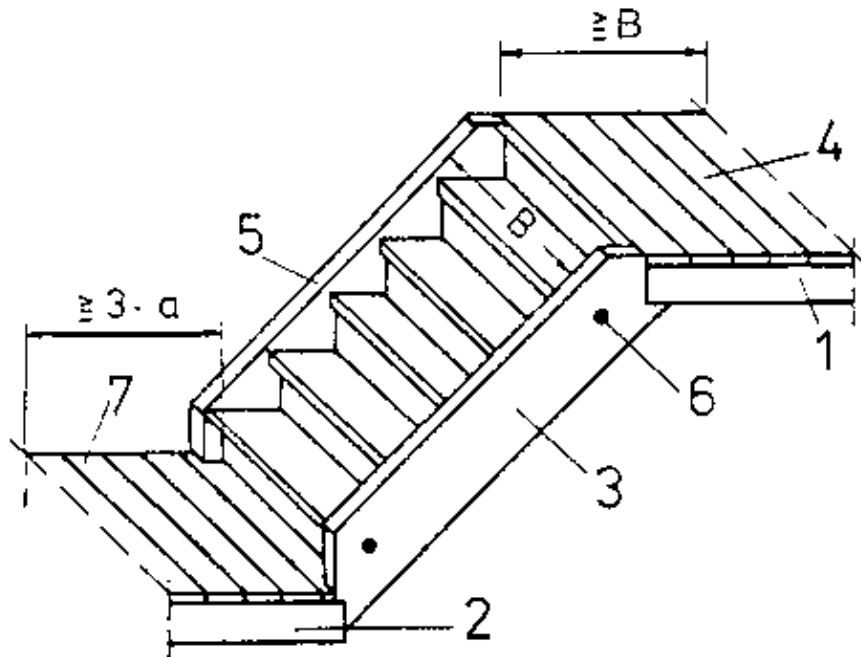

Figure 13 – Representation of the lengths of the main landing and half-landing – 1 main landing, half-landing, 3 outer string, 4 surface – main landing (surface – flooring), 5 wall string, 6 rosette, 7 surface half-landing (surface flooring), **B** stair flight width

A stair landing need not always be clearly visible, the half-landing for example. It may pass into the floor ceiling with no noticeable transition point. With wooden stairs, the landings support the flight of stairs. The bottom landing must resist and distribute horizontal and vertical forces, the top landing horizontal forces only.

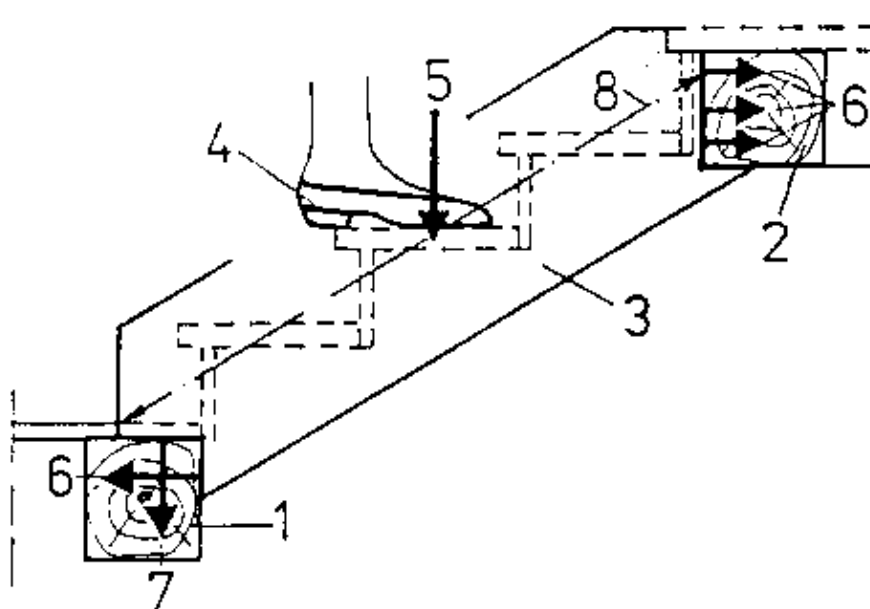

Figure 14 – Distribution of forces in the bottom and top landings – 1 lower stair–apron, 2 upper stair–apron, 3 stair string, 4 load on the stairs by user, 5 acting force by user, 6 force acting horizontally, 7 force acting vertically, 8 force acting diagonally between the two landings

Stairwell

The stairwell is the space intended for building–in the staircase.

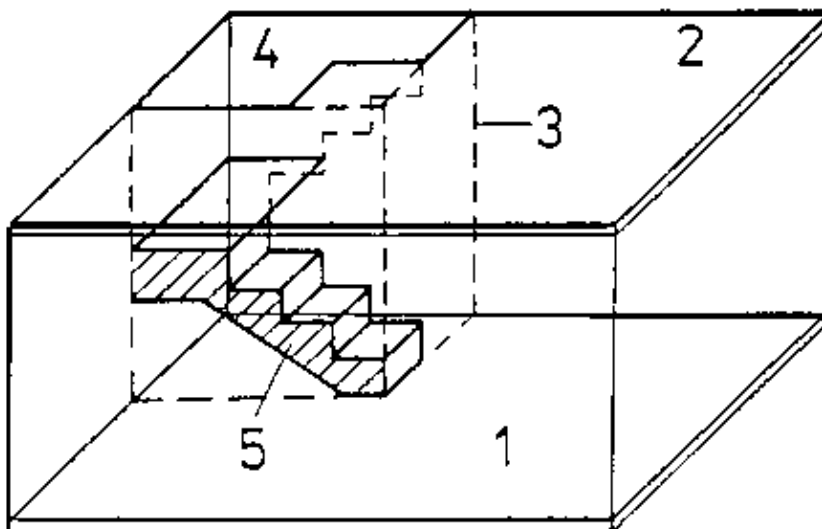

Figure 15 – Representation of the stairwell – 1 lower floor–ceiling, 2 upper floor–ceiling, 3 stairwell, 4 opening in the upper floor–ceiling, 5 stairs with half–landing to be built in

It is limited in length by the existing opening in the upper floor–ceiling and in the height by the surfaces of the floor ceilings.

The width depends on the type of stairs to be built in. The height between floors decides on the type of stairs to be built in.

The dimensions for the stairs to be built are to be taken from the stairwell and to be compared with the existing drawing.

The stairwell height is always based on the surface of the finished floors!

In order to compare the dimensions taken with the drawing, a hand–sketch is to be drawn and completed by the dimensions taken.

In the case of mortised stairs, 40 mm are to be deducted from the stairwell length to prevent the necessary riser from contacting the stair-apron!

The stair strings only must contact the stair-apron (see Fig. 16).

What does the term "stairwell" mean?

Drawing floor

In order to build a straight wooden staircase, only the top and bottom connections to landings need to be drawn (scale 1: 1) on the drawing floor.

It is not necessary to take into account the measured flight length and flight height.

The required angle of inclination of the flight is obtained by drawing (scale 1:1) two treads and two heights of rise at the top stair-apron.

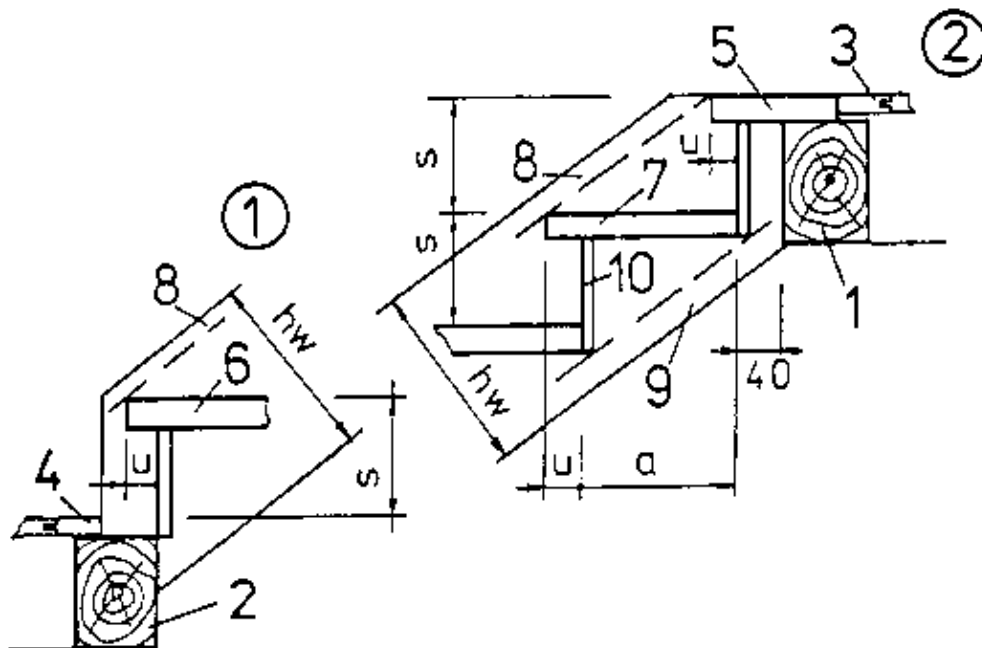

Figure 16 – Drawing of the top and bottom string connections at the stair-aprons – (1) bottom connection (2) top connection – 1 lower (bottom) stair-apron, 1 upper (top) stair-apron, 3 floor construction of the top landing, 4 floor construction of the bottom landing, 5 stair head (head step), 6 stair foot (bottom step), 7 step, 8 string top, 9 string bottom, 10 riser, – a tread width, s height of rise, u false tread, h_w string height

The angle of inclination can be laid off to the bottom connection by means of a bevel protractor.

A flat, clean plate is used as drawing floor.

It is also possible to use clean boards nailed onto supporting strips.

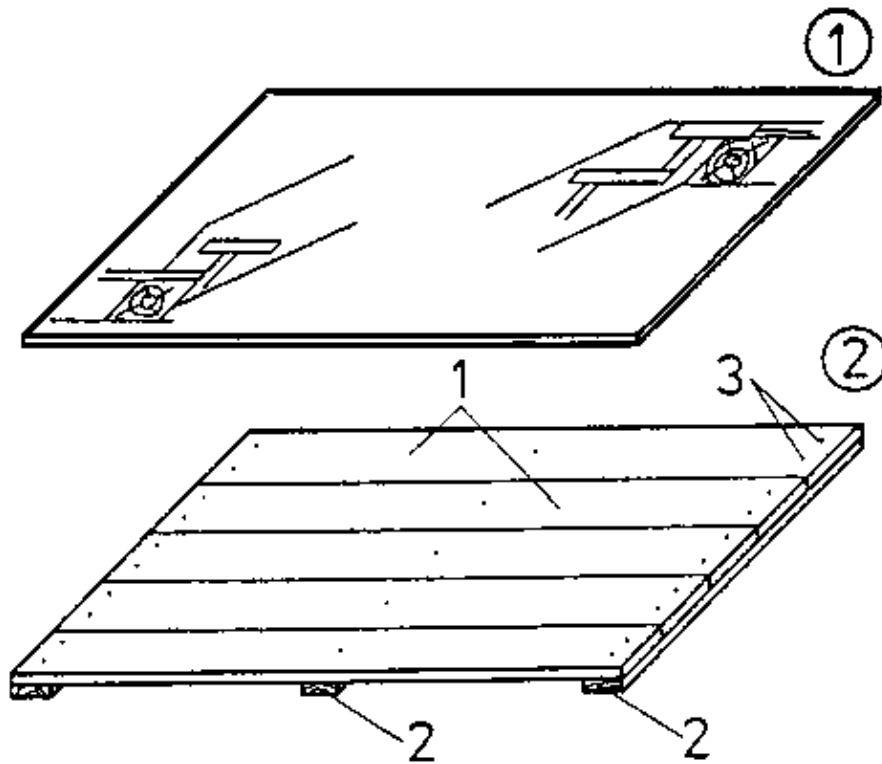

Figure 17 – Representation of a drawing floor – (1) flat, clean plate (2) drawing floor made from boards – 1 boards, 2 supporting strings, 3 nails

Stair strings

The stair strings carry the steps in 20 mm deep mortises. The string height can be measured from the drawing floor (see Fig. 16).

The string length can be determined by means of the approximation formula

$$L_w = (n_s + 0.5) c \quad (\text{Formula 10})$$

L_w = length of the posts for the stair string

c = size between the front edges of the steps.

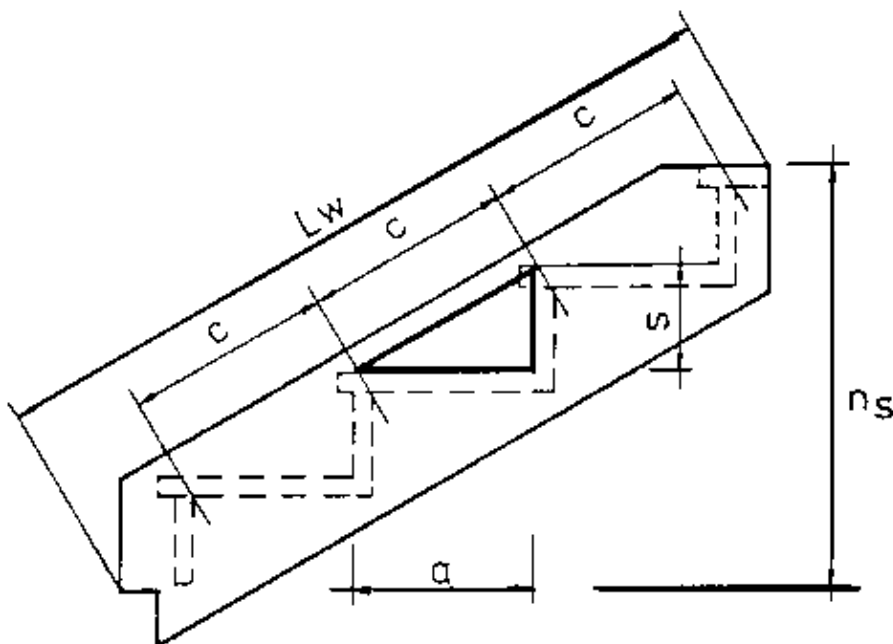

Figure 18 – Sketch for determining the stair string length – a tread width, s height of rise, n_s number of rises, L_w length of posts for the stair string, c length at a rise triangle

The size "c" can be measured from the drawing floor. The thickness of the string should be at least 50 mm. It is recommended to plane the posts for the stair string on four sides prior to scribing, making sure that they are in parallel. The dimensional tolerances in thickness and height may be ± 1 mm.

Steps

The steps must all be cut to the same length ($B + 2 \cdot 20$ mm).

"B" is the clear width of the stair flight (see Fig. 13). They must all have the same length to be uniformly fixed (clamped) when the stair strings are drawn together by the screw rods.

If some steps are not fixed (clamped) by drawing together, they will squeak when stepped on.

The steps are surfaced on one small side and one wide side and then thickened.

After that the width is scribe-marked. For width scribing it is important that the width of the steps must have the size of the tread width (go width) plus false tread.

For sawing-out of the steps, 2 mm are to be added and will be removed by planing after sawing-out (see

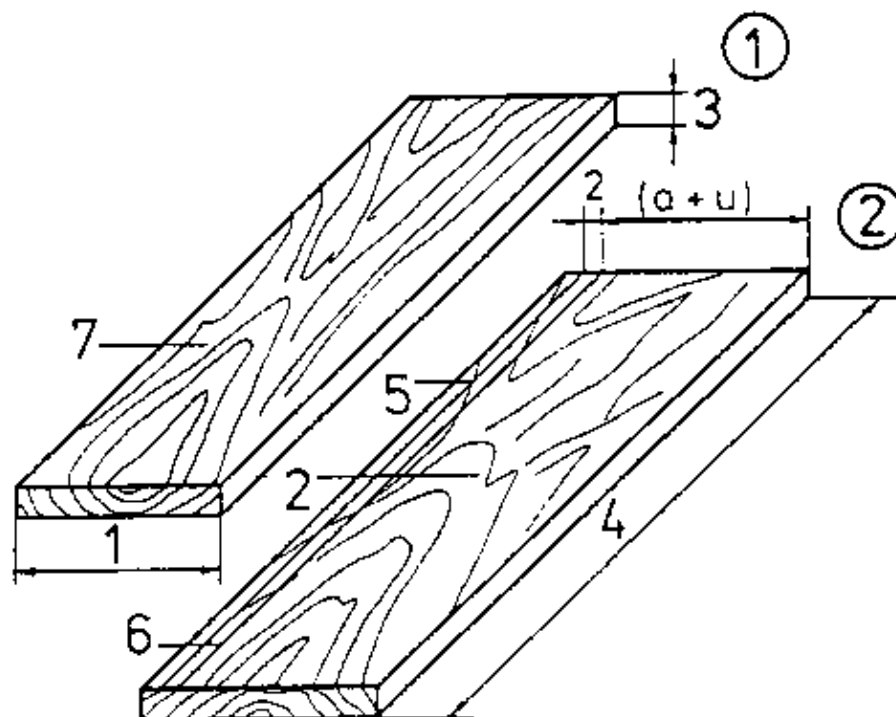

Figure 19 – Connection between rough-step size and finished-step size – (1) rough step (2) finished and scribe-marked step – *a* tread width from the calculation, *u* false tread, – 1 wide side of the step, 2 left side of the step, 3 small side of the step, 4 length of the step, 5 scribed line for sawing to width of step, 6 scribed line of exact width of step, 7 right side of the step

When preparing the steps it is to be considered that the left side of the wood is to be stepped on!

How deep should the steps be mortised into the stair string?

Risers

The risers are to be cut 4 mm shorter than the steps. They must not be clamped by drawing together of the stair strings. The risers must have a slight cove upwards of approx. 2 mm to provide good support to the steps in the flight line when being stepped on. For preparing and planing of the risers the same working steps are required as for the steps.

Stair railing

The railing protects the user of the stairs from falling down at the side. It consists of the bottom post, the head post and the hand-rail.

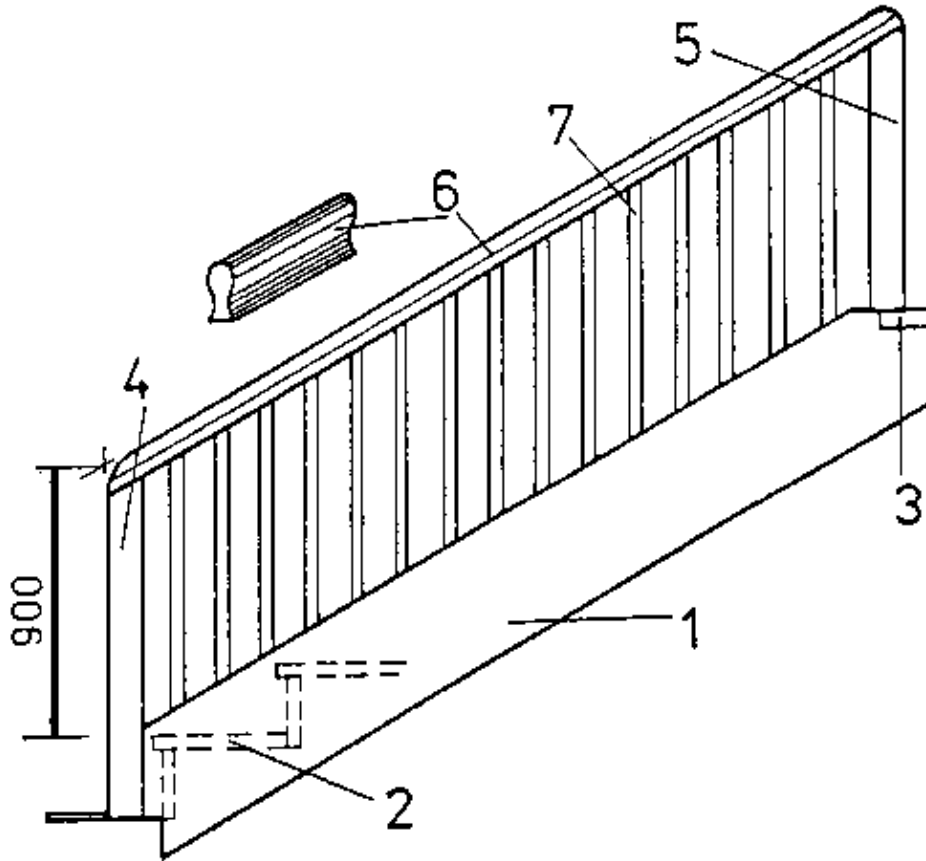

Figure 20 – Stair railing with vertical railing bars – 1 outer string, 2 bottom step, 3 head step, 4 bottom post, 5 head post, 6 hand-rail, 7 vertical railing bar

Protection between the hand-rail and the outer string can be achieved by unprofiled or profiled vertical railing bars. The railing bars are mortised into the hand-rail. At the bottom end, the railing bars can be mortised directly into the outer string. But it is also possible to use a baseboard for the railing bars to be mortised into. The tenon in the railing bar is spot-faced to avoid back-mortising in the hand-rail, outer string or baseboard.

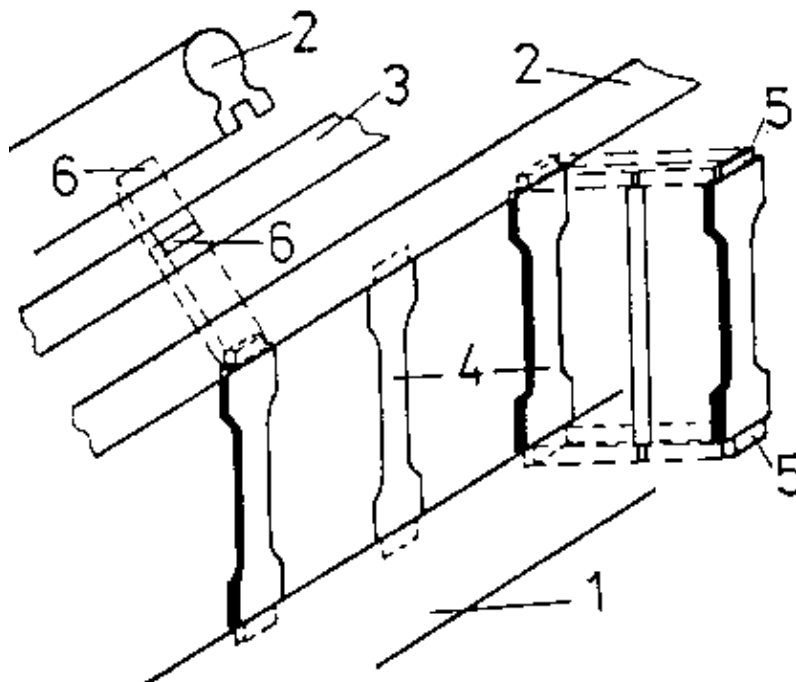

Figure 21 – Representation of the mortise-and-tenon joints of the railing bars – 1 outer string, 2 hand-rail, 3 underside of the handrail, 4 railing bar (profiled), 5 tenon of the railing bar, 6 mortise in the hand-rail

The hand-rail is to be designed so as to permit easy gripping of it and convenient sliding on it. Side-protection at the outer string can also be achieved by bars which are in parallel with the hand-rail.

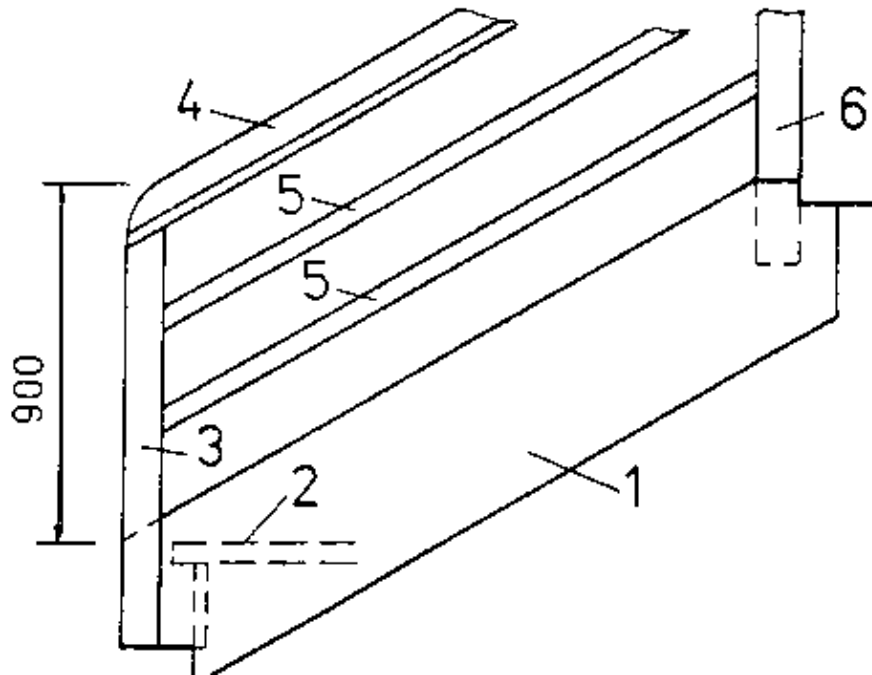

Figure 22 – Stair railing with parallel bars – 1 outer string, 2 bottom step, 3 bottom post, 4 handrail, 5 railing bars, 6 head post

The distance between the railing bars is to be chosen so that children cannot slip through the bars.

The bottom and head posts can be connected with the outer string by a simple lap joint.

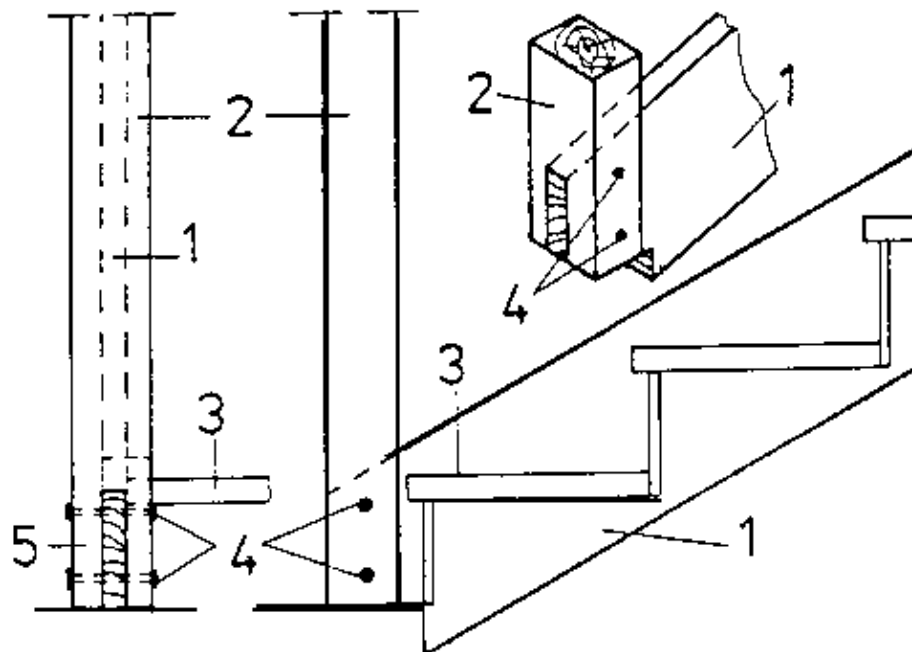

Figure 23 – Lap joint between railing post and outer string – 1 outer string, 2 railing post, 3 bottom step, 4 machine screw, 5 lap joint

For better stability of the railing posts, they can also be connected with the outer string by a slit-and-tongue-joint.

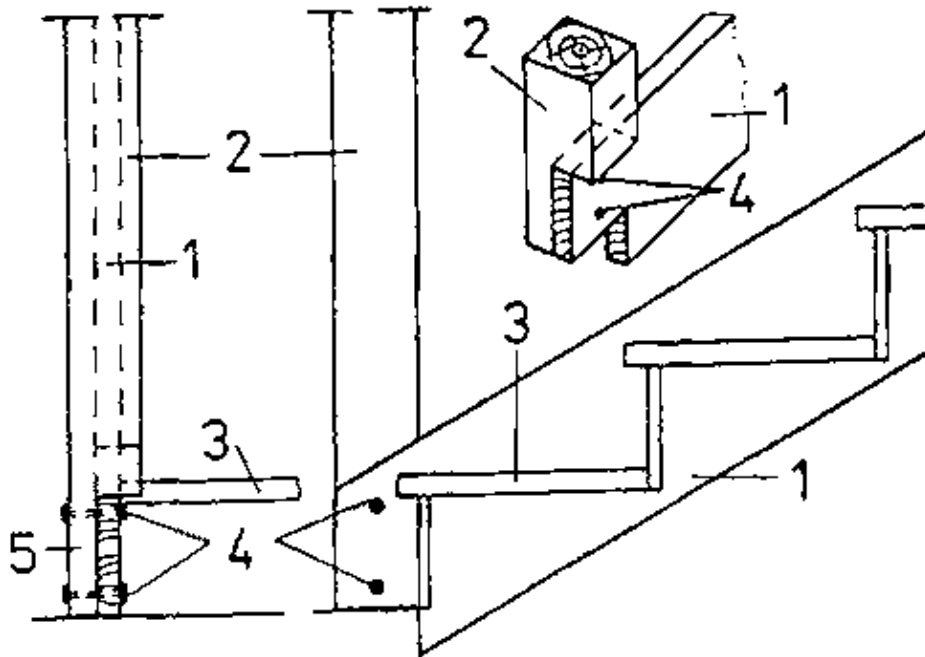

Figure 24 – Slit-and-tongue joint between railing post and outer string – 1 outer string, 2 railing post, 3 bottom step, 4 machine screw, 5 slit-and-tongue joint

The railing posts can be glued or screwed to the outer string. The screw heads can be covered by rosettes.

What is the purpose of stair railings?

4. Taking off Dimensions at the Stairwell

Two different types of dimensions are taken off at the stairwell: layout dimensions (plan view) or height dimensions. Wooden staircases may also be built in between solid ceilings. In that case, the surface of the bare ceiling is decisive instead of the surface of the stair-apron (see Fig. 28).

Taking off layout dimensions

The size of the existing or planned opening for the staircase is transferred from the upper floor-ceiling by plumbing.

The plumb points are marked on the lower floor-ceiling and then connected by means of a straightedge (straight, parallel, planed board of 20 – 30 mm thickness, 140 mm width and 2000 – 3000 mm length). A marking-out drawing is drawn.

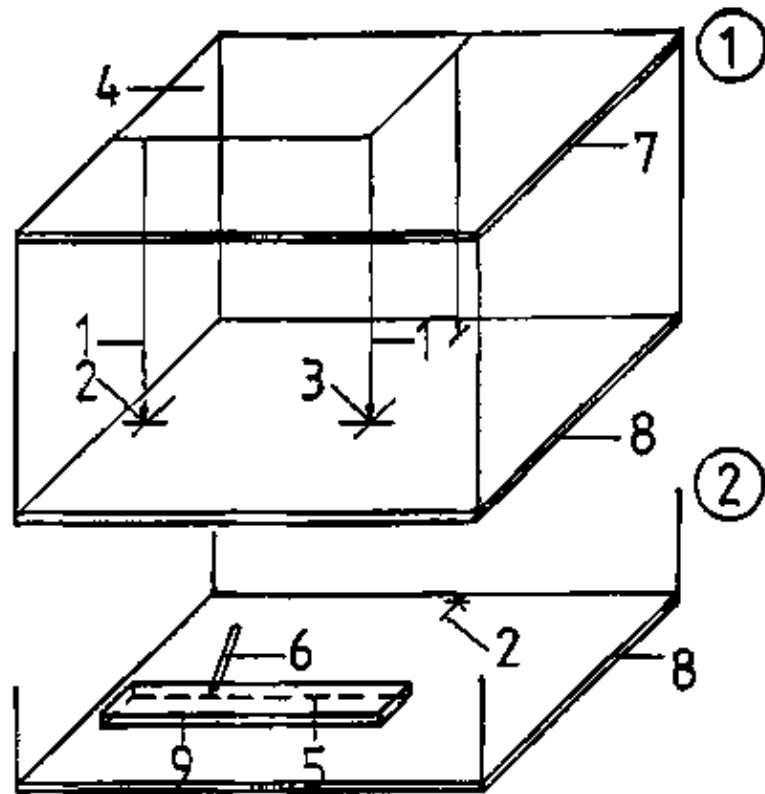

Figure 25 – (1) Transferring of dimensions to the lower floor–ceiling (2) Connecting of marked points with the straightedge – 1 plumb cord, 2 marked point, 3 plumb body, 4 opening in the upper floor–ceiling, 5 applied straightedge, 6 pencil, 7 upper floor–ceiling, 8 lower floor–ceiling, 9 straightedge

The squareness of the stairwell is checked on the lower floor–ceiling. A self–made builder's square, joined by means of the proportional numbers 3:4:5 and nailed, is used for this purpose.

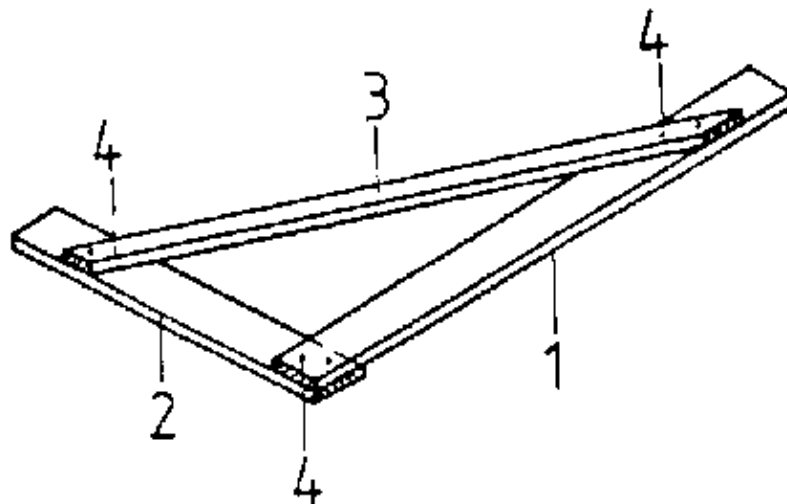

Figure 26 – A builder's square – 1 longer, straight strip for true alignment, 2 shorter, straight strip for true alignment, 3 strip for stiffening (bracing) the two straight strips, 4 nail

All dimensions taken off are written into a hand–sketch.

Checking of squareness

The angle between the stair flight range and the range at the stair head in the main landing or half–landing is checked. If the two ranges are not square with each other, the right angle is prescribed.

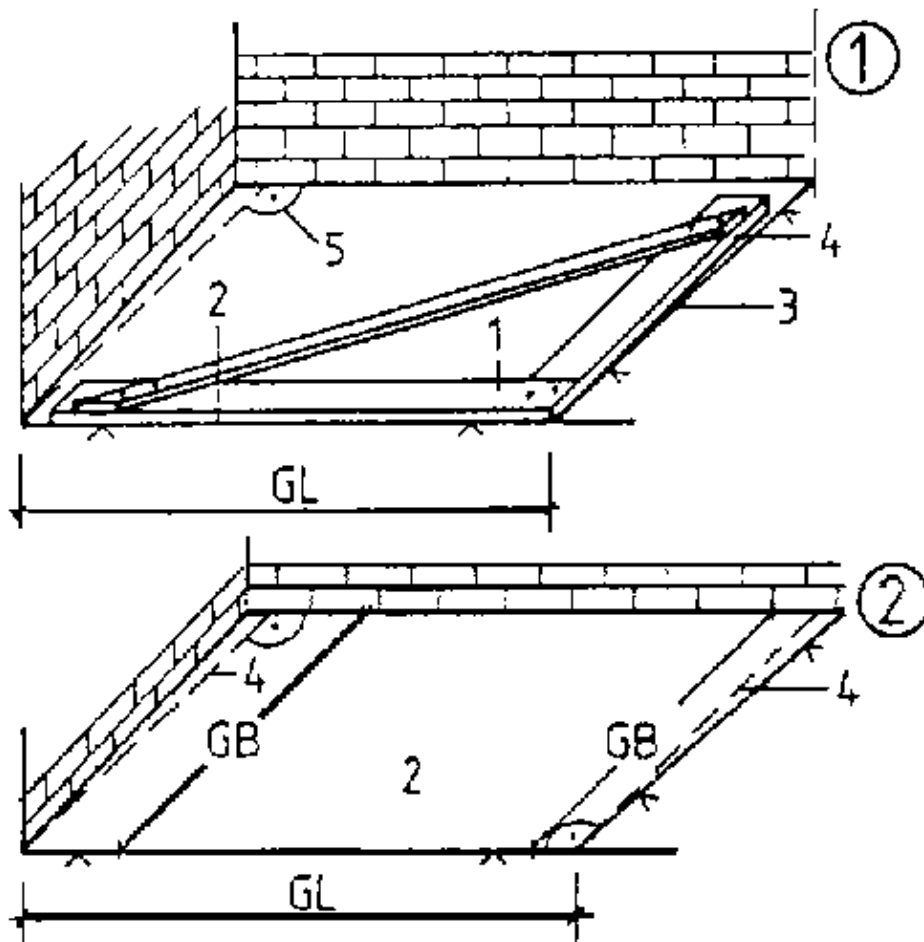

Figure 27 – (1) Checking of squareness of the stairwell – 1 builder's square, 2 applying the square to the stair flight range, 3 border of the upper floor-ceiling, 4 squareness with the stair flight range, 5 squareness of the wall corner – (2) Determination of the size of the stairwell 2 stair flight range, 4 right (square) angle with the stair flight range, **GB** stairwell width, **GL** stairwell length

Prescribing of the right angle is based on the stair flight range and the smallest size of the stairwell length is written into the hand-sketch.

When the finished staircase is built in, the difference can be made-up (padded with wood) at the stair apron.

Taking off height dimensions at the stairwell

In this connection it is important to know whether the height dimensions are to be taken off at stairwells with or without half-landing. The height dimensions take priority for the calculation of the ratio of rise and tread because the staircase to be manufactured is to be built in between the landings with finished floor with a height of rise of $s = 200$ mm. This means that the height dimensions in the stairwell are not in any case equal to the dimensions for the stair flight height.

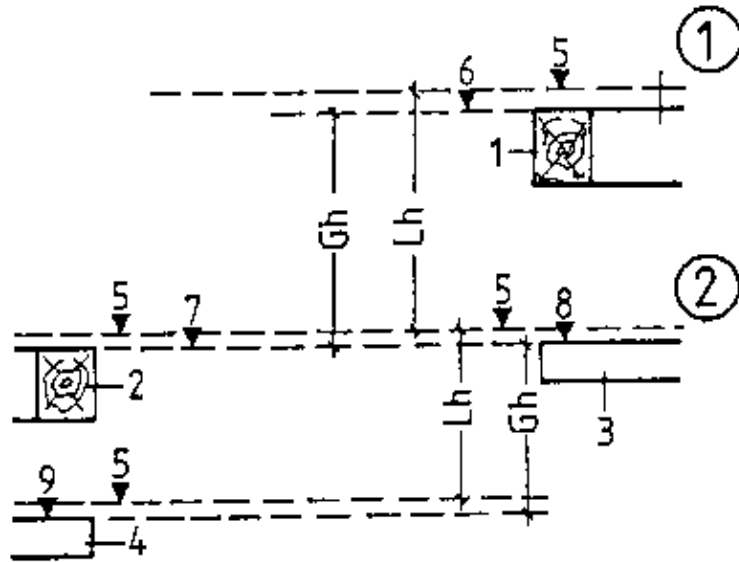

Figure 28 – Connection between stairwell height and stair flight height – (1) with wood joist ceiling (2) with solid ceiling – 1 upper stair-apron, 2 lower stair-apron, 3 upper solid ceiling, 4 lower solid ceiling, 5 surface of finished floor, 6 surface of upper stair-apron, 7 surface of lower stair-apron, 8 surface of upper bare ceiling (solid ceiling), 9 surface of lower bare ceiling – **Gh** stairwell height, **Lh** stair flight height

The staircase must be built in between the landings with finished floor. Therefore the stairmaker must know the floor construction of the two landings.

The size for the stair flight height results from the following consideration:

$$Lh = Gh - d_1 + d_2 \quad \text{(Formula 11)}$$

Gh = stairwell height between two landings of different levels

d_1 = floor thickness of the bottom landing

d_2 = floor thickness of the top landing

Taking off height dimensions without half-landing

The perpendicular height between the surfaces of the stair-aprons or bare ceiling at the head and foot of the stairs to be built in is measured. The stair flight height is then determined applying formula 11.

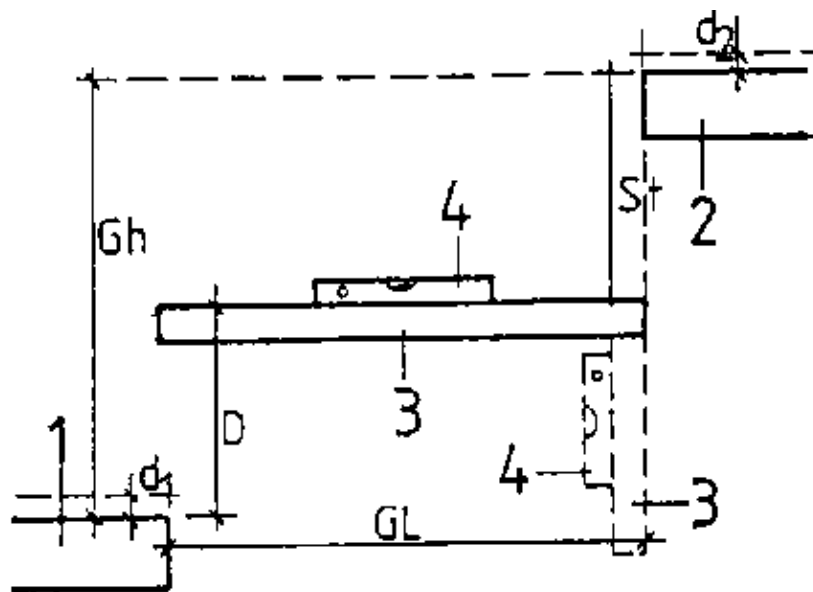

Figure 29 – Taking off height dimensions without half-landing – 1 bottom landing, 2 top landing, 3 straightedge, 4 water level, – d_1 floor thickness of bottom landing, d_2 floor thickness of top landing **Gh** stairwell height, **GL** stairwell length, **St** gauge size, **D** difference size

The stair flight height thus determined is used for the calculation of the ratio of rise and tread.

Taking off height dimensions with half-landing

Together with the height measurement, the length for the stair flights to be built in is determined.

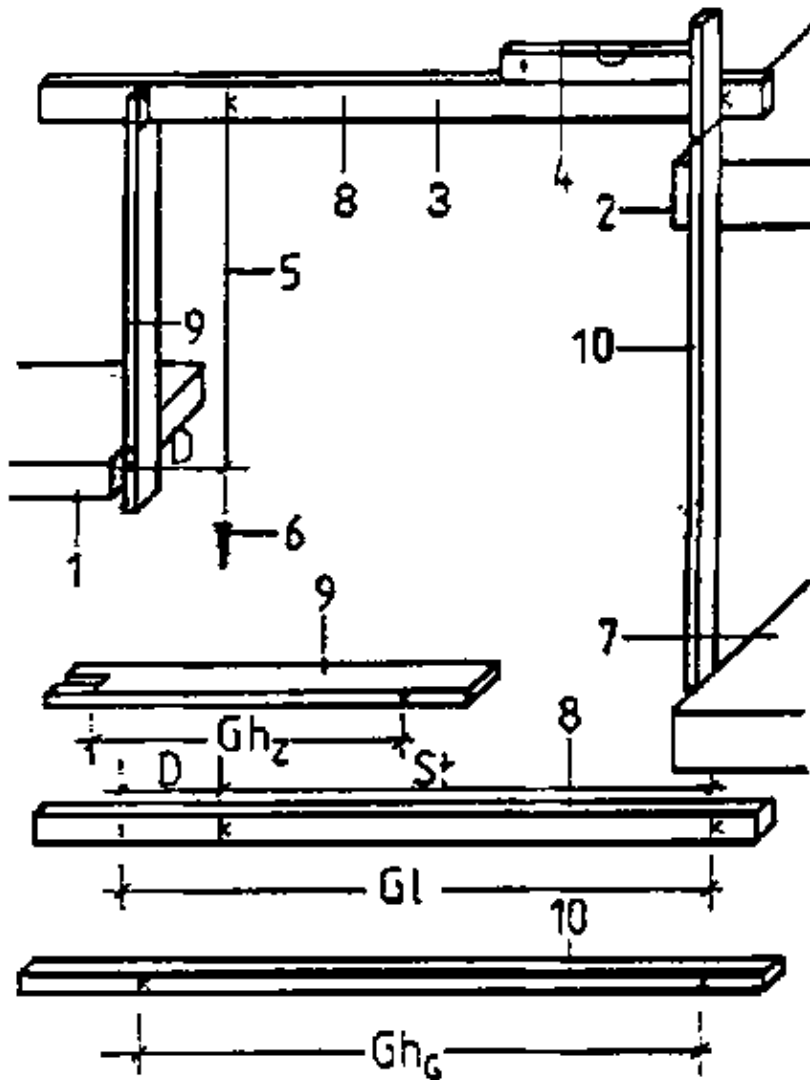

Figure 30 – Taking off height dimensions with half-landing – 1 bottom landing {half-landing, 2 top landing (main landing) (upper floor-ceiling), 3 straightedge, 4 water level, 5 plumb cord, 6 plumb body, 7 bottom landing (main landing) (lower floor-ceiling), 8 straightedge serving as measuring batten at the same time, 9 batten to support the straightedge and serving as measuring batten at the same time, 10 measuring batten between the two floor-ceiling – *D* difference size, *GH_z* stairwell height at half-landing, *GH_G* stairwell height between the floor-ceiling, *GL* stairwell length, gauge size

Sequence of operations:

- The plumb cord is fixed to the straightedge.
- The straightedge is put on the top apron.

The end, which the plumb cord is fixed to, is supported by a batten. The batten is held perpendicularly at the half-landing by a second person.

- A water level is put onto the straightedge and levelled by raising or lowering the batten at the half-landing.
- When the straightedge is exactly horizontal, the batten is pressed to the half-landing and the height marking is scribed.

– When the pendulum movement of the hanging plumb has stopped, the gauge size between the plumb cord and the front edge of the stair–apron is measured. At the same time the front edge of the top landing is scribed to the straightedge.

The two sizes, the gauge size and the size on the straightedge between the plumb cord and the front edge of the top landing, are the length of the stairwell.

– Measuring of the height of the stairwell between the two main landings. (Use a batten!) The scribed sizes on the battens 8, 9, 10 in Figure 30 can be measured with a folding rule!

– Checking whether the height of the half–landing (height with finished floor) will fit into the calculated ratio of rise and tread.

The half–landing with its finished floor must be located at a height of $n_s \cdot s$!

If this is not the case, the half–landing must be removed and built in again at the necessary height. If this is not done, the two stair flights within one storey will have a different ratio of rise and tread!

A different ratio of rise and tread within stairs with two apposed branches of flights (180 degrees turn) and landing must be avoided, otherwise climbing of such stairs is not safe!

The batten used for supporting the straightedge must be slotted on top to prevent the straightedge from slipping off.

Drawing the hand–sketch

A hand–sketch is to be drawn on a sheet of paper which need not be true to scale.

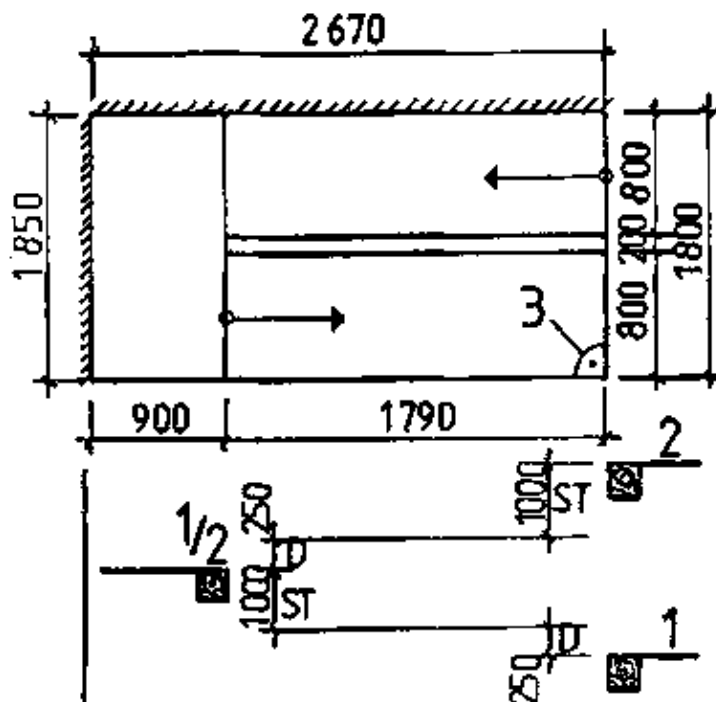

Figure 31 – Hand–sketch with stairwell dimensions written into it – 1 lower stair–apron, 2 upper stair–apron, 3 determined right angle, – D difference size, St gauge size

All dimensions taken off are to be written into such sketch. In the plan view length and width of the stairwell and in the elevation the height dimensions of the stairwell are to be shown.

On the basis of such sketch, the sizes for the stairs to be built will be determined and the ratio of rise and tread calculated.

Why must the dimensions of the drawing be compared with the dimensions of the stairwell?

5. Calculations for Stairmaking

Example 1:

A staircase of saddle stairs with a flight width of 1250 mm is to be built in. What perpendicular height must the string bottom have when the height of rise is 190 mm?

Required: h_u

Known: $s = 190 \text{ mm}$

$W_d = 65 \text{ mm}$ (Table 2)

Formula:
$$h_u = 40 \text{ mm} \left(\frac{s}{W_d} + 2 \right)$$
 (Formula 1)

Calculation:
$$h_u = 40 \text{ mm} \left(\frac{190 \text{ mm}}{65 \text{ mm}} + 2 \right) \quad h_u = 169.9 \text{ mm}$$

$h_u = 200 \text{ mm}$ chosen

The string bottom must have a perpendicular height of 200 mm.

Example 2:

A staircase has a tread width of 288 mm and a height of rise of 171 mm. What is the ratio of rise and tread of this staircase?

Required: m

Known: $a = 288 \text{ mm}$

$s = 171 \text{ mm}$

Formula:
$$m = \frac{a}{s}$$
 (Formula 5)

Calculation:
$$m = \frac{288 \text{ mm}}{171 \text{ mm}}$$
 (Don't work out, just delete the unit of measurement!)

$$m = \frac{288}{171}$$

The ratio of rise and tread of the stairs is $\frac{288}{171}$

Example 3:

A tread width of 286 mm and a height of rise of 172 mm have been measured at inserted stairs. What is the step size for climbing such stairs?

Required: Sm

Known: $a = 286 \text{ mm}$

$s = 172 \text{ mm}$

Formula: $S_m = a + 2s$ (Formula 2)

Calculation: $S_m = 286 \text{ mm} + 2 \cdot 172 \text{ mm}$ $S_m = 630 \text{ mm}$

The step size is 630 mm.

Example 4:

A vertical distance of 1750 mm has been measured between two landings. The stairs to be built in shall have a height of rise of 170 mm.

How many rises will such stair flight have?

Required: n_s

Known: $L_h = 1750 \text{ mm}$

$s_g = 170 \text{ mm}$

Formula: $n_s = \frac{L_h}{s_g}$ (Formula 4)

Calculation: $n_s = \frac{1750 \text{ mm}}{170 \text{ mm}} = 10.29$ $n_s = 11$

The stair flight will have 11 rises.

Example 5:

For mortised stairs with 10 rises the stair flight height is 1680 mm. What is the height of rise for such stairs?

Required: s

Known: $L_h = 1680 \text{ mm}$

$n_s = 10$

Formula: $s = \frac{L_h}{n_s}$ (Formula 3)

Calculation: $s = \frac{1680}{10} \text{ mm}$ $s = 168 \text{ mm}$

The height of rise of such stairs is 168 mm.

Example 6:

A stair flight has 12 treads. The tread width is 283 mm. What is the length of such stair flight?

Required: L

Known: $n_a = 12$

$a = 283 \text{ mm}$

Formula: $L = n_a \cdot a$ (Formula 6)

Calculation: $L = 12 \cdot 283 \text{ mm}$ $L = 3396 \text{ mm}$

The stair flight length is 3396 mm.

Example 7:

A stair flight length of 3124 mm is available for mortised wooden stairs. The stairs shall have 11 treads. What is the tread width of the stair steps?

Required: a

Known: L = 3124 mm

$n_a = 11$

Formula: $a = \frac{L}{n_a}$ (Formula 7)

Calculation: $a = \frac{3124\text{mm}}{11}$ a = 284 mm

The tread width of the stair steps must be 284 mm.

Example 8:

What is the stair flight height of stairs having 8 rises with a height of rise of 175 mm?

Required: a

Known: $n_s = 8$

s = 175 mm

Formula: $L_h = n_s \cdot s$ (Formula 8)

Calculation: $L_h = 8 \cdot 175 \text{ mm}$ $L_h = 1400 \text{ mm}$

The stair flight height is 1400 mm.

Example 9:

A stair flight height of 1215 mm has been measured at the stairwell. The stairs to be built in shall be climbable with a step size of 630 mm.

What is the ratio of rise and tread for climbing such stair flight?

Required: m

Known: $S_m = 630 \text{ mm}$

$L_h = 1215 \text{ mm}$

$s_g = 190 \text{ mm}$ (Formula 5)

Formula: $m = a/s$

$a = S_m - 2s$

$$s = \frac{L_h}{S_g}$$

Calculation: $n_s = \frac{1215\text{mm}}{190} = 6.3$ $n_s = 7$

$n_s = \frac{1215\text{mm}}{7}$ $s = 173.5 \text{ mm}$

$a = 630 \text{ mm} - 2 \cdot 173.5 \text{ mm}$ $a = 283 \text{ mm}$

$m = \frac{283\text{mm}}{173.5\text{mm}}$ $m = \frac{283}{173.5}$

The ratio of rise and tread of the flight is $\frac{283}{173.5}$

Exercise 1

Mortised stairs shall be calculated to the step size. A stair flight height of 1344 mm has been measured.

- How many treads must be available?
- What is the tread width of the stairs?
- What is the consequent ratio of rise and tread of such stairs?

a) Required: n_a

Known:

$$n_s = \frac{Lh}{s_g}$$

$Lh = 1344 \text{ mm}$

$s_g = 180 \text{ mm}$

Formula: $n_a = n_s - 1$

Calculation: $n_a =$

b) Required: a

Known: $S_m = 630 \text{ mm}$

$$s = \frac{Lh}{n_s}$$

$Lh = 1344 \text{ mm}$

$n_s = 8$

Formula: $a = s_m - 2s$

Calculation: $a =$
 $=$

c) Required: m

Known: $a = 294 \text{ mm}$

$s = 168 \text{ mm}$

Formula: $m = \frac{a}{s}$

Calculation: $m =$

Exercise 2

Saddle stairs shall be built in with a stair flight width of 1300 mm and a height of rise of 170 mm. What height must the string bottom have?

Required: h_u

Known: $s = 170 \text{ mm}$

$W_d = 70 \text{ mm}$ (Table 2)

Formula:

$$h_u = 40 \text{ mm} \left(\frac{s}{W_d} + 2 \right)$$

Calculation: $h_u \text{ chosen} = \text{mm}$

Exercise 3

A single-flight staircase has 15 treads with a ratio of rise and tread of 278/176.

What length does this stair flight have?

Required: L $L = n_a \cdot a$

Known: $n_a = 15$

$a = 278 \text{ mm}$

Formula: $L = n_a \cdot a$

Calculation: $L = \text{mm}$

Exercise 4

A floor-to-floor height of 2656 mm has been measured at the stairwell. A straight staircase with two opposed branches of flights (180 degrees turn) and landing shall be built in. The length of landing is 800 mm. The height of rise shall not exceed 172 mm. The two stair flights shall have the same length.

- a) How many rises will one stair flight have?
- b) What length must the stairwell have if the stairs are to be built to the step size?

a) Required: n_s

Known:

Formula:

Calculation: $n_s =$ _____

b) Required: GL

Known:

Formula:

Calculation: $GL =$ _____ mm

Exercise 5

A staircase with inserted stairs has 8 treads with a tread width of 290 mm. What is the stair flight height of such stairs?

Required:

Known:

Formula:

Calculation: $L =$ _____ mm

6. Assembly of the Stair Components

Assembly of the stair flight

Single-branch flights of wooden stairs are normally assembled in the workshop and transported to the stairwell as a complete unit.

The assembly of flights of saddle stairs is relatively simple because the steps (treads) are screwed onto the sawn-out stair strings. Accuracy to size is an important criterion in screwing on the steps.

The screws should be surface-treated or be made of nonferrous heavy metal so as to avoid rusting and mean appearance when the steps are cleaned by water.

Saddle stairs assembled in the workshop are secured against displacement during transportation by means of a diagonal strip.

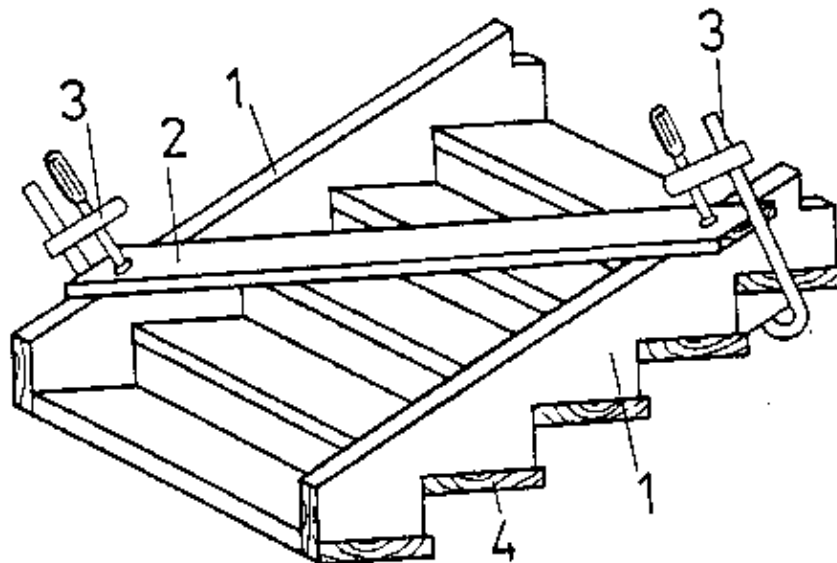

Figure 32 – Stair flight stiffened with diagonal strip (saddle stairs –underside view) – 1 sawn-out stair string, 2 diagonal strip, 3 screw clamp, 4 left side of step

Screw clamps or ferrules are used for fixing the diagonal strip. To prevent marks in the wood, the lower surface of the string bottom is padded by wooden pads and the steps are padded by wedges having the shape of the rise triangles.

In the case of inserted stairs without arris for insertion of the steps, the stair foot and stair head may be inserted in the mortise (insertion slot) and the stair string be slightly drawn together with the screw rods.

To avoid displacement of the stair strings during assembly, a square-cut board with a length equal to the clear width of the stair flight is clamped between the stair strings. Such board must have a sufficient width and be clamped immediately in the area of the screw rods. This will prevent the stair strings from being drawn together too much.

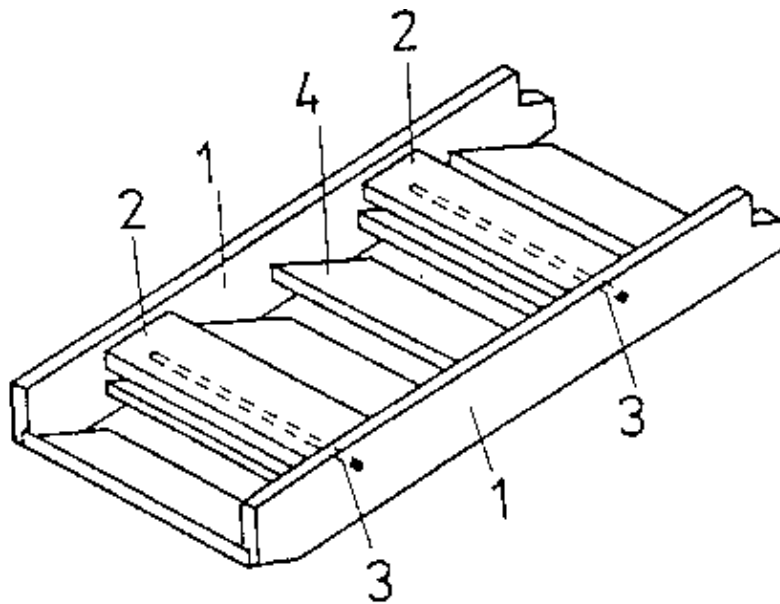

Figure 33 – Stair flight stiffened with square-cut board (inserted stairs – underside view) – 1 stair string, 2 square-cut board for stiffening, 3 drawn-in screw rod, 4 inserted step

The remaining steps are slid into the insertion slots from the front (see Fig. 7/2). The steps must tightly fit in the insertion slots. If necessary, a hammer may be used for beating in.

Be careful: Use a wooden pad when beating with the hammer to avoid beating marks.

In the case of inserted stairs with arris for insertion of the steps, the steps are inserted, one after the other, into the insertion slots until half of the tread width. Then the steps are, one by one, beaten in cm by cm. A wooden pad is to be used so as not to leave beating marks.

The procedure with mortised stairs is as follows:

- Wooden pads of equal thickness are placed on a flat workshop floor at 500 mm intervals for putting-on the stairs strings.
- The two stair strings are put on the wooden pads flush with each other and with the mortised holes for holding the steps and risers showing upward.

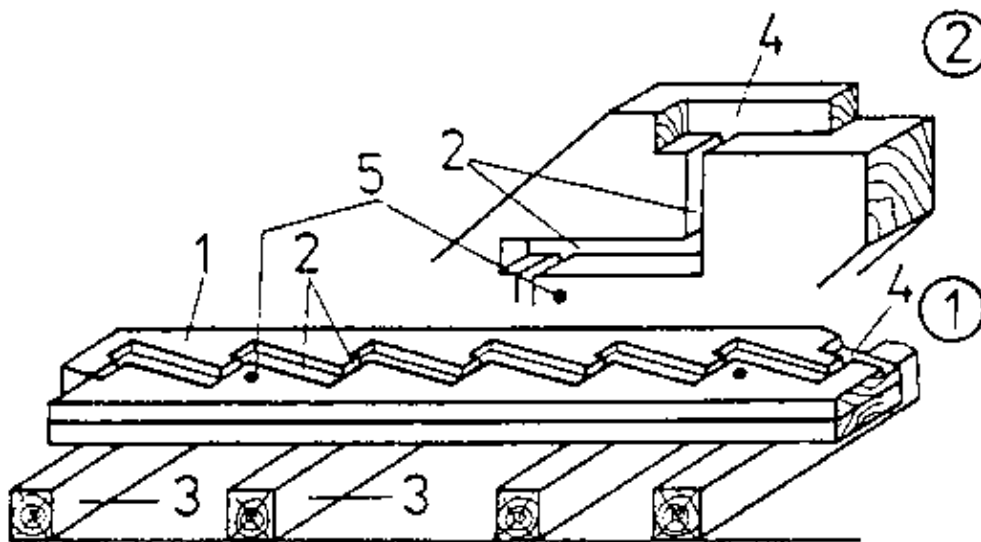

Figure 34 – (1) mortised stair strings put on flush with each other (2) magnified view of the top part of the stair string – 1 stair string, 2 mortised hole for step and riser, 3 wooden pads, 4 accommodation for the head step, 5 drilled hole for the screw rod

- Under the second and last but one steps, in the centre of the stair string, the holes for the screw rods are scribe–marked and drilled vertically into the stair string with a diameter corresponding to the diameter of the screw rods.
- The outer string remains on the wooden pads. The screw rods are put through the drilled holes and the washers and nuts are attached between the workshop floor and the outer string.
- The steps are inserted, one by one, into the mortised holes for holding the steps and risers.

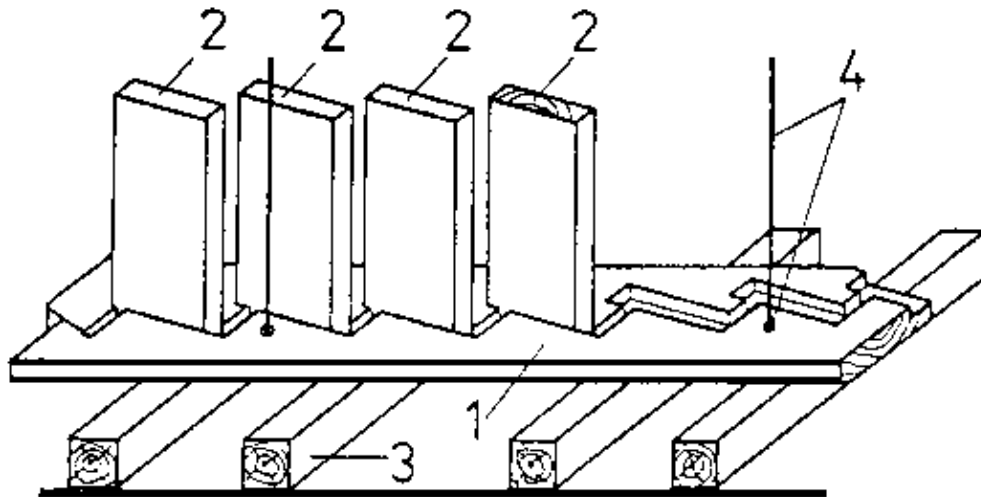

Figure 35 – Insertion of the steps into the mortised holes – 1 stair string, 2 step, 3 wooden pad, 4 screw rod

- A board is put on the inserted steps and the steps are beaten in by a beating tool until the bottom of the hole.

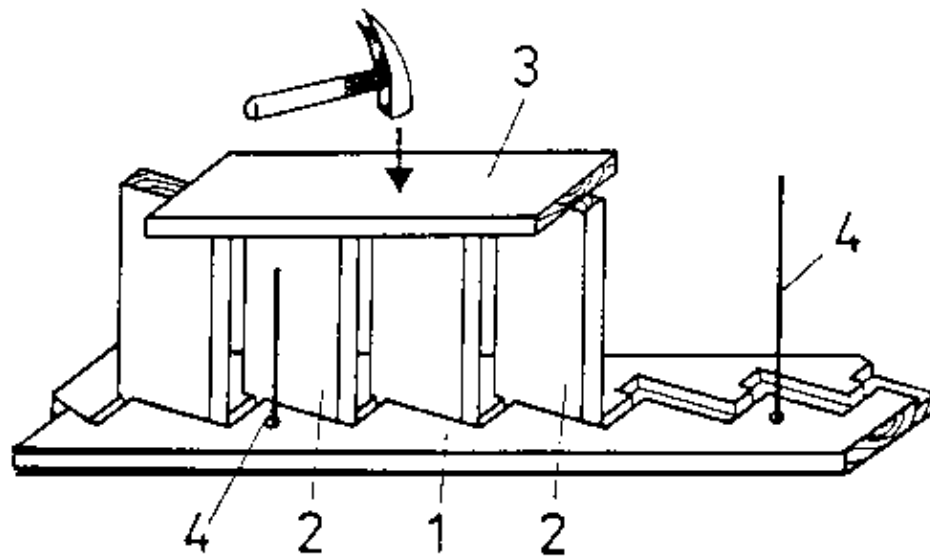

Figure 36 – Beating–in of the steps – 1 stair string, 2 step, 3 wooden pad (to avoid bearing marks), 4 screw rod

- The risers are inserted and, if necessary, beaten–in.

A wooden pad is to be used for beating in. When beating in it is to be made sure that the risers sit 2 mm deeper on top than the steps.

- The wall string is placed on top and the steps and risers are put into the holes (not fully inserted).

Figure 37 – Placing the stair string on top of the steps and risers beaten in – 1 stair string, 2 step, 3 mortised hole for step, 4 step, 5 mortised hole for riser, 6 drilled hole for screw rod, 7 left side of step (go side), screw rod

- The screw rods are passed through the drilled holes in the wall string, the washers are attached and the nuts slightly screwed on.
- A post–piece is put on the wall string to beat the wall string tightly in.
- When all steps and risers are beaten into the mortised holes, the nuts are finally tightened and the stair flight width is checked.
- Any excessive thread of the screw rods is sawn off.
- The rosettes are screwed on.
- The stair strings, steps and risers are sanded with abrasive paper to remove any scribe–marks of pencils and to make the stairs look clean.

Building in of the stairs

First the assembled stair flight is put on the bottom stair–apron with the carved foot provided at the bottom and then it is slowly inclined towards the top apron until it contacts it.

It is to be made sure that the stair strings uniformly contact the stair aprons to avoid displacement of the stair flight. If necessary, the strings are to be recut or packed.

List of symbole and technical terms used in stairmaking

- s = tread width
- B = staircase width (width of stairs)
- c = length between the front edges of the step surfaces, measured in the stair inclination
- d_1 = floor thickness of the bottom landing
- d_2 = floor thickness of the top landing
- GL = stairwell length
- h_u = height of the perpendicular string bottom
- h_w = string height
- L = flight length
- Lh = flight height
- l = flight line
- L_w = length of the posts for the string
- m = ratio of rise and tread
- n_a = number of treads
- n_s = number of rises
- Sm = step size
- s = height of rise (treads)
- s_g = height of rise chosen (assumed)
- u = false tread
- W_d = string thickness