

## **Fish Handling, Preservation and Processing in the Tropics: Part 2 (NRI)**

 **(introduction...)**

 **Summaries**

 **Acknowledgements**

 **Introduction**

 **Salting of fish: salt**

 **Salting of fish: methods**

 **Drying of fish: basic principles**

 **Drying of fish: methods**

 **Smoking of fish**

 **Marinades**

 **Fermented fish products: a review**

 **Boiled fish products**

 **Fish canning: theory and practice**


 **Freeze drying**

 **Irradiation**

 **Miscellaneous products: crustaceans**














 **Miscellaneous aquatic products used as food**

 **Food by-products**

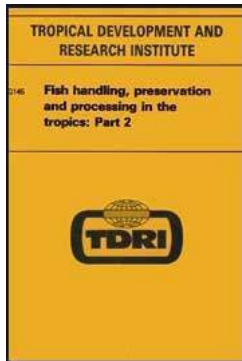
 **Non-food by-products**










 **New and delicatessen products**


 **Fish meal**

-  **Fish silage**
-  **Chemical and physical methods of quality assessment**
-  **Organoleptic (sensory) measurement of spoilage**
-  **Microbiology of spoilage**
-  **Microbiology of fish spoilage**
-  **Public health microbiology**
-  **International standards for fisheries products**
-  **Large-scale fish landing facilities**
-  **Small-scale landing facilities: design and operation**
-  **Retail sale facilities**
-  **Fisheries extension services: their role in rural development**
-  **Training in the field**
-  **Appendix**

[Home](#) > [ar](#) [cn](#) [de](#) [en](#) [es](#) [fr](#) [id](#) [it](#) [ph](#) [po](#) [ru](#) [sw](#)



-  **Fish Handling, Preservation and Processing in the Tropics: Part 2 (NRI)**
-   **(introduction...)**
-  **Summaries**
-  **Acknowledgements**
-  **Introduction**
-  **Salting of fish: salt**
-  **Salting of fish: methods**
-  **Drying of fish: basic principles**

-  **Drying of fish: methods**
-  **Smoking of fish**
-  **Marinades**
-  **Fermented fish products: a review**
-  **Boiled fish products**
-  **Fish canning: theory and practice**
-  **Freeze drying**
-  **Irradiation**
-  **Miscellaneous products: crustaceans**
-  **Miscellaneous aquatic products used as food**
-  **Food by-products**
-  **Non-food by-products**
-  **New and delicatessen products**
-  **Fish meal**
-  **Fish silage**
-  **Chemical and physical methods of quality assessment**
-  **Organoleptic (sensory) measurement of spoilage**
-  **Microbiology of spoilage**
-  **Microbiology of fish spoilage**
-  **Public health microbiology**
-  **International standards for fisheries products**
-  **Large-scale fish landing facilities**
-  **Small-scale landing facilities: design and operation**
-  **Retail sale facilities**
- 

 **Fisheries extension services: their role in rural development**  
 **Training in the field**  
 **Appendix**

**TDRi Tropical Development and Research Institute**

**Compiled by I. J. Clucas with contributions from**

**R. C. Cole**

**I. J. Clucas**

**T. W. Bostock {Tropical Development and Research Institute**

**J. F. Rogers**

**A. D. Stephens**

**G. B. Debling**



**M. Clifford {Grimsby College of Technology**

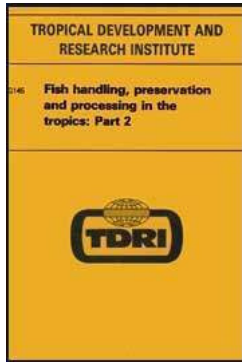
**W. Homer**

**September 1982 Tropical Development and Research Institute**  
**(Reprinted 1985 127 Clerkenwell Road, London EC1R 5DB**  
**and 1990) Overseas Development Administration**










**[Home](#)** > **[ar.cn.de.en.es.fr.id.it.ph.po.ru.sw](#)**

- 
-  **Fish Handling, Preservation and Processing in the Tropics: Part 2 (NRI)**
  -  ***(introduction...)***
  -  **Summaries**
  -  **Acknowledgements**



- 📄 **Introduction**
- 📄 **Salting of fish: salt**
- 📄 **Salting of fish: methods**
- 📄 **Drying of fish: basic principles**
- 📄 **Drying of fish: methods**
- 📄 **Smoking of fish**
- ➔ 📄 **Marinades**
- 📄 **Fermented fish products: a review**
- 📄 **Boiled fish products**
- 📄 **Fish canning: theory and practice**
- 📄 **Freeze drying**
- 📄 **Irradiation**
- 📄 **Miscellaneous products: crustaceans**
- 📄 **Miscellaneous aquatic products used as food**
- 📄 **Food by-products**
- 📄 **Non-food by-products**
- 📄 **New and delicatessen products**
- 📄 **Fish meal**
- 📄 **Fish silage**
- 📄 **Chemical and physical methods of quality assessment**
  
- 📄 **Organoleptic (sensory) measurement of spoilage**
- 📄 **Microbiology of spoilage**
- 📄 **Microbiology of fish spoilage**
- 📄 **Public health microbiology**

-  **International standards for fisheries products**
-  **Large-scale fish landing facilities**
-  **Small-scale landing facilities: design and operation**
-  **Retail sale facilities**
-  **Fisheries extension services: their role in rural development**
-  **Training in the field**
-  **Appendix**

## **Marinades**

**Marinades are made by preserving fish and shellfish in a mixture of acetic acid and salt; the resulting product has an extended shelf life and characteristic flavour. Pelagic fish, with a high fat content in the flesh, such as herrings and sardines, are normally the raw material for the preparation of marinated products. Good quality marinades can only be made from high quality raw material.**

**The acetic acid produces the tenderness characteristic of marinades; this is largely due to the action of certain of the proteolytic enzymes which cause a partial breakdown of the proteins with the release of some free amino acids. This gives the products their characteristic taste. The fat content of the flesh is also important in giving the characteristic flavour. Some of the acetic acid combines chemically with the proteins while the remaining acid controls the pH and selectively allows the autolytic reactions to take place.**

**The salt (sodium chloride) causes the removal of water and coagulates the protein. It also controls the hydrolytic action and allows it to proceed within desired limits.**

**Marinades may be conveniently divided into three groups:**

**(i) Cold marinades: in which raw fish, with or without the backbone, are preserved in a mixture of acetic acid and salt. At no stage during the process are the fish heated.**

**(ii) Cooked marinades: the fish are placed in a hot solution (+85°C) of acetic acid and salt. At approximately 85°C, most of the bacteria are killed and the enzymes are inactivated (denatured).**

**(iii) Fried marinades: the fish are fried or baked before being packed in an acetic acid and salt solution. The frying kills most of the bacteria and denatures the enzymes.**

**Examples of each type of marinade are given below.**

### **Cold marinades**

**A pH of 4.5 is considered the optimum for most cold marinade products. At pH 4.5 and approximately 10 per cent salt, most bacterial activity is halted; some activity does occur and this contributes to the characteristic flavour of marinades. Since autolytic and bacterial activity occur, the shelf life of cold marinated products is limited, even under chill storage conditions. Eventually reactions will occur that produce off-flavours and make the product unacceptable. Shelf life at chill temperatures may be several months; at tropical ambient temperatures it may only be a few weeks.**

### **Preparation of cold marinades - herring**

**The following recipe is for herring:**

- 1. Wash the fish in a 10 per cent salt solution (brine) to harden them and remove slime.**
- 2. Head, gut or fillet as required.**
- 3. Wash in a 5 per cent brine to remove traces of blood from the muscle.**

**4. Immerse in a solution containing 7 per cent acetic acid and 14 per cent salt for up to three weeks. The strength of the solution depends on the ratio of fish to solution and the type of product required. If the fish are held at chill temperatures, the strength of the solution may be reduced. If the fish are held at high ambient temperatures, a stronger solution may be necessary to prevent spoilage. The process will proceed more rapidly at higher temperatures. If the acid and salt concentrations are too high the characteristic flavours may not be developed. The container should be full and have a tightly fitting lid; otherwise the fish may develop rancid flavours.**

**5. Packing: after the marinating process is completed, the flesh should be firm, white, opaque and tender. Discard any discoloured pieces. Glass jars are frequently used to pack the final product; the fish or fish pieces are packed in the jars and covered with a solution containing 1 - 2 per cent acetic acid and 2 - 4 per cent salt. The acid taste of the final product may be reduced by substituting citric or tartaric acid for some or all of the acetic acid; the pH of the final solution should not be more than 4.5. Spices, such as coriander, cloves, peppers and bay leaves, may be added to the final pack to improve the flavour.**

### **Cooked marinades**

**1. Pretreatment: washing, cutting and pre-salting are similar to those processes used for cold marinades.**

**2. Bleaching: the fish or pieces of fish are spread on perforated trays that are immersed in a bleaching bath containing 1 - 2 per cent acetic acid at 85° C; some salt may also be added. Normally, 10 - 15 minutes immersion is adequate; a slightly longer time may be necessary for larger pieces.**

**3. Cooling: after bleaching, the product should be cooled with cold, clean water to remove fat and protein foam.**



**4. Packing: glass, porcelain or laquered cans may be used. Spices may be added to the final pack as required. With some European products, the fish are packed in a jelly. The jelly or final liquid should contain 1 - 2 per cent acetic acid and 3 per cent salt.**

### **Fried marinades**

**1. Pretreatment: cleaning, cutting and pre-salting as with cold marinades. After draining, the fish or fish pieces are breaded.**

**2. Frying: the breaded fish are fried for 5 - 12 minutes in fat at a temperature between 160 and 180°C. If a deep fat system is used, frying can be considered completed when the fish or fish pieces rise to the surface (the specific gravity is altered as fat is absorbed and water is lost).**

**3. Packing: the fish are packed in cans and covered with a brine containing 2 - 3.5 per cent acetic acid and 3 - 5 per cent salt. As with the other types of marinade, spices may be added to taste.**

### **Shelf life**

**Marinades have a limited storage life because of the methods of preparation used. Cooked and fried marinades are not usually given sufficient heat treatment to make them sterile. Spoilage of marinated products occurs in differing ways depending upon the cause:**

**(i) Physical spoilage: if a pack is frozen, expansion of the contents may damage the glass jar or tin can.**

**(ii) Chemical spoilage: the acetic acid will attack the metal of a can if the cans are badly laquered or tinned. The action of the acid on the metal will cause the formation of hydrogen which may cause the can to swell. Metal dissolved in the acid may alter the**

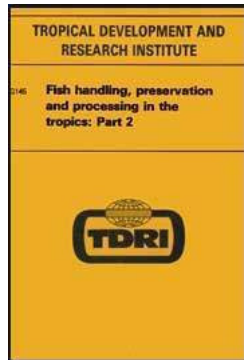
## flavour of the product.

(iii) **Biological spoilage:** the protein of the fish itself may be broken down to such an extent that off-flavours develop due to the action of bacteria or autolytic enzymes. If any of the spices or other additives contain sugar, bacteriological fermentation may occur.

Since marinated products are not sterile, it is essential that preparation is only carried out under hygienic conditions. All containers, working surfaces, tools and ingredients should be clean.



[Home](#) > [ar](#).[cn](#).[de](#).[en](#).[es](#).[fr](#).[id](#).[it](#).[ph](#).[po](#).[ru](#).[sw](#)



## **Fish Handling, Preservation and Processing in the Tropics: Part 2 (NRI)**

 **(introduction...)**

 **Summaries**

 **Acknowledgements**

 **Introduction**

 **Salting of fish: salt**

 **Salting of fish: methods**

 **Drying of fish: basic principles**

 **Drying of fish: methods**

 **Smoking of fish**

 **Marinades**

 **Fermented fish products: a review**

-  **Boiled fish products**
-  **Fish canning: theory and practice**
-  **Freeze drying**
-  **Irradiation**
-  **Miscellaneous products: crustaceans**
-  **Miscellaneous aquatic products used as food**
-  **Food by-products**
-  **Non-food by-products**
-  **New and delicatessen products**
-  **Fish meal**
-  **Fish silage**
-  **Chemical and physical methods of quality assessment**
-  **Organoleptic (sensory) measurement of spoilage**
-  **Microbiology of spoilage**
-  **Microbiology of fish spoilage**
-  **Public health microbiology**
-  **International standards for fisheries products**
-  **Large-scale fish landing facilities**
-  **Small-scale landing facilities: design and operation**
-  **Retail sale facilities**
-  **Fisheries extension services: their role in rural development**
-  **Training in the field**
-  **Appendix**

## **Fermented fish products: a review**

**The fermentation processes are those in which organic catalysts (enzymes or ferments) break down complex organic molecules to simpler ones. The enzymes responsible for digestion in the higher animals were once referred to as digestive ferments. Alcoholic fermentation is a process in which sugars are converted to alcohol with the evolution of carbon dioxide; yeast enzymes are commonly used and this process is important in the production of beers, wines and spirits.**

**If wet fish protein, that is fish flesh, is protected from contamination by microorganisms, and if the enzymes present in the flesh are rendered inactive, the flesh does not break down. It would, in fact, remain stable for a considerable period. Many of the processes used in fish preservation aim at keeping the fish flesh as near as possible to its original condition. With fermentation, however, we are considering methods by which the wet protein is broken down to simpler substances which are themselves stable at normal temperatures. In some of the processes we shall be considering, breakdown is only partial and is controlled by the addition of salt; thus the process is designed to produce a particular flavour as well as to preserve the product. Sometimes the breakdown is effected by enzymes present in the fish (autolysis); sometimes micro-organisms are involved. In many cases, the breakdown is hydrolysis or 'splitting-with-water'.**

**Three quite different types of product can be recognised:**

- 1. Products in which the fish retain, substantially, their original form or in which large chunks of fish are preserved.**
- 2. Products in which the original fish are reduced to the form of a paste.**
- 3. The so-called fish sauces in which the flesh is reduced to a liquid.**

**Very few of these processes are employed outside Asia.**

## **Fermented fish**

**Any fish which are subjected solely to a salting process are likely to be subject to a degree of fermentation. The degree of fermentation depends on factors such as whether the fish are completely or partially gutted; the proportion of salt used; the fat content of the fish; which additives, if any, are added during the salting process; and, finally, the temperature at which the salted fish are kept. The temperature is particularly important: using precisely the same process but holding the fish at a higher temperature than is normal may produce a quite different result.**

### **Herring**

**Herring (*Clupea harengus*) were formerly used for a variety of different types of product. The commonest of these was pickled herring. The fish were typically dry salted in barrels, the proportion of salt varying from 15 to 36 per cent in different cures. A brine formed and covered the fish; in most cures, the barrels were topped up after a period with fish and brine from the same day's curing. There were special cures known as, e.g., Dutch, Scotch and Icelandic. Fish pickled in this way could be kept for more than one year at European ambient temperatures. The fish flesh was then only very moderately softened; the ripening process took several months. Such products typically contained 10-12 per cent salt; the only bacteria which would survive in these conditions would be salt-tolerant or halophilic. When fermentation was to be encouraged a proportion of sugar was added to the salt, and spices such as peppers, mace, coriander, hops, cinnamon, ginger, cardamom and even sandalwood were also added. Benzoic acid was sometimes used as a preservative; boric acid was also used until recently by some packers but is now generally prohibited.**

### **Anchovies**

**Cured anchovies are a delicacy popular in the Mediterranean area. The only genuine anchovies are made from *Engrautis encrasicolus* by salting and fermentation. Although**

**similar processes are sometimes applied to sardines and to sprats, the product is not of comparable quality. The best anchovies for curing weigh about 35 - 40 fish to the kg and they should have as high a fat content as possible. They are headed and gutted by pulling off the head without any particular care. The fish are salted down in layers, using from 5 to 6 kg of salt per 10 kg of anchovies. A final layer of salt is put on top and a weighted wooden disc is used to keep the fish well pressed. A brine forms, the fish sink down under the brine and additional fish and salt may be added a few days later. The fish are kept in the brine under pressure for a period of at least 6 - 7 months. During this time, water and fat are pressed out of the fish and form a layer of brine covered with fat. The liquid overflows and is collected and later used to spray the anchovies during the cure. The process can be carried out in sterile containers using sterile salt and it would thus appear that no micro-organisms are involved in the process. Traditionally, the cured anchovies are sold from the containers in which they have been manufactured; these vary from wooden barrels holding 50 to 200 kg to hot-dipped tin plate cans (plain on the inside and laquered on the outside) holding 20 kg; however, the fish are now sometimes filleted and packed in small retail cans.**

### **Mackerel**

**In the tropics fermented fish are often made from the various mackerel species, especially Scomberomorus commerson. In India, a specialised cure known as the Colombo cure is used in South Kanara. Absolutely fresh fish are gutted, the gills are removed and the fish washed in seawater. They are then rubbed with salt (ratio 1:3) and put in cement tanks. About 8 kg of the fruit of Garcinia camboges, which is similar to tamarind, is added per tonne of fish. The fruit is extremely acid. Fish remain in the brine which forms for 2 - 4 months and are then exported packed in wooden barrels. The fish are reported to keep well for a year or more. The same fish used to be salted in Aden in cement tanks using about 1 part of salt to 3 parts of fish and the brine was allowed to flow away. No acid fruit pulp was used. These fish were exported in a very soft condition, sewn up in palm leaf**

**bags, to the East Coast of Africa. A number of other products, including Makassar fish, are made in Asia; many of these include a proportion of cooked rice.**

### **Shrimp and fish pastes**

**These should not be confused with the fish pastes made in Western countries, for little, if any, fermentation takes place in these; they are typically made merely by comminuting fish flesh, which might be smoked as a preliminary.**

**The processes used in making fermented fish pastes are all essentially similar to one another. Typically, the fish or shrimps are pounded with a proportion of salt so that a paste results; this is subjected to varying periods of sun drying before being packed to mature in a container from which air is excluded. Sometimes a period of sun drying follows salting before any comminution is attempted. The moisture content of a typical paste varies from 35 to 50 per cent so that almost half the water present in the fresh material would have been lost during processing.**

**Typical pastes include the ngapi of Burma, the pra hoc and various mams of Cambodia, belachan of Malaysia and the trassi of Indonesia. Trassi may be made from shrimp or fish. Details of the process vary almost from village to village but, typically, where sun drying is possible, the raw material is sun dried for a day before it is salted. After sun drying, the material is traditionally pounded in a wooden mortar; the following day the dough is exposed for a second time. Later the product is pounded and mixed with salt. In some cases, the raw material is salted in the catching vessels and is only later subjected to sun drying. The Malaysian process for making belachan is similar: the raw or partially dried material used to be crushed in wooden trays by a treading process similar to that in which wine is made; nowadays, the process has been mechanised and butchers' choppers are used for the mixing and pounding.**

**In a typical process, Acetes shrimp (udang gragok, udang team ng) and smaller**

**proportions of mysid shrimp are used. The process is as follows:**

- 1. The fish and larger prawns are sorted from the catch so that only the smaller shrimp remain.**
- 2. The small shrimp are mixed with salt in bamboo baskets or wooden tubs using a ratio of 4 - 5 kg salt: 100 kg wet shrimp.**
- 3. The pickled shrimps are spread out in thin layers on mats to dry in the sun.**
- 4. Drying continues for 4 to 8 hours; about 50 per cent of the moisture is evaporated. The material is again sorted and rubbish, fish and crabs are removed.**
- 5. The salted shrimps are minced and then pressed into a paste in wooden tubs or boxes. It is important that all air bubbles are excluded at this time.**
- 6. The minced paste ferments for up to 7 days and is then dug out of the tub and spread to dry in the sun for 3 - 5 hours. The paste is then minced again and returned to the wooden tubs where it ferments for about a month. It is then minced for a third time and packed in blocks wrapped in cellophane or brown paper.**

**The yield of paste is 40-50 per cent of the raw shrimp weight. A typical analysis of good quality belachan is as follows:**

pH	7.6 - 7.8
Moisture	27 - 40 per cent
Ash (including salt)	20 - 24 per cent
Salt	13 - 18 per cent
Protein	30-40 per cent

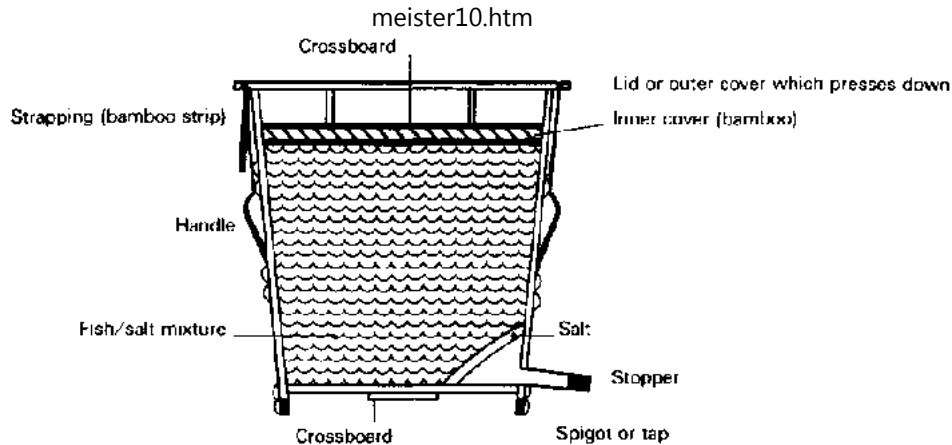


**Artificial colouring matter such as Rhodamine B has sometimes been used to produce the desired deep pink colour. Some curers have been observed to be most liberal in their application of this poisonous dye. There are no records of anyone being poisoned by these materials but it would be advisable to replace them with one of the safer food colours.**

### **Fish sauces**

**In these processes, the fermentation of the fish is carried out for a longer period than in the manufacture of fermented fish and fermented fish paste; the sauces are liquids containing a mixture of amino acids and other protein degradation products. They are thus similar to soya sauce; like soya sauce, they have high salt contents and this is a limitation to their use as a food; they are used principally as condiments for flavouring rice dishes, indeed they may be eaten with plain boiled rice. They are also freely used in vegetable cookery.**

**In the manufacture of the classic sauces such as the nuoc-mam of Cambodia and the nam-pla of Thailand, fish are mixed with salt in tubs or vats and left to stand for periods varying from 5 to 18 months. Figures 1 and 2 illustrate the type of vat used for the manufacture of nuoc-mam. The best sauces are made from anchovies (*Stolephorus* spp.); a typical process is as follows:**



Bottom boards are let into the side

**Source:** Redrawn from Figure 19 in Food and Agriculture Organization of the United Nations Regional Office for Asia and the Far East, Bangkok (1967). *Indo-Pacific Fisheries Council Regional Studies No. 4, Fish processing in the Indo-Pacific area*, compiled by G. N. Subba Rao.

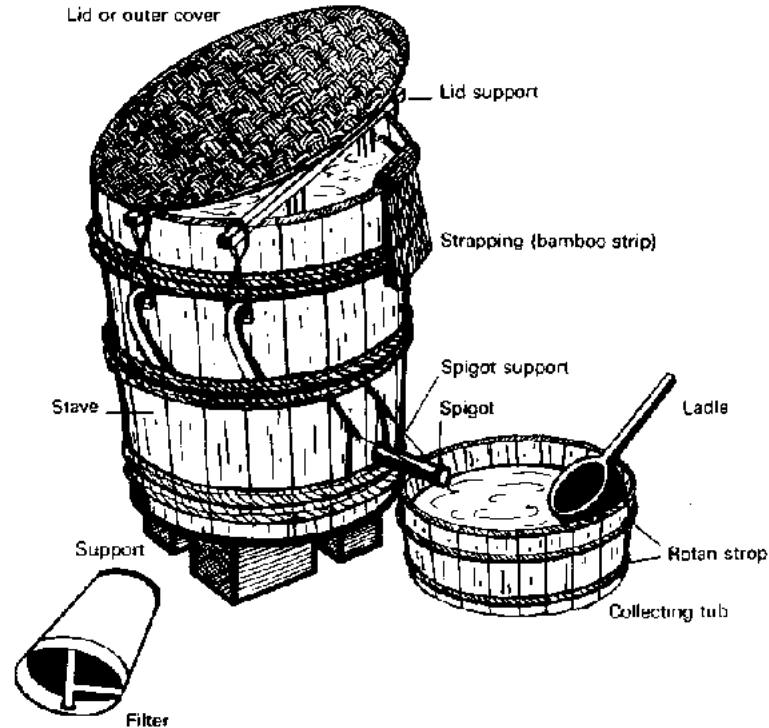
**Figure 1 - Vietnam: Section of the vat used for making nuoc-mam (Courtesy Institut Oceanographique de Nha-Trang)**

**1. The fish are washed in sea water and then mixed with salt in tubs or vats made of wood or cement, the ratio of fish to salt being from 1:5 to 1:1. A weight is also placed on top to keep the fish below the brine.**

- 2. The vat stands for 5 to 18 months then the clear liquid is skimmed off the top or drained through a spigot near the bottom of the container.**
- 3. The liquid is then filtered and bottled or barrelled and exposed in the sun until it is ripe.**
- 4. The liquid sauce is finally packed in bottles or earthenware containers for distribution.**

**After the first liquid has been drawn off at stage 2 the residue may be extracted several times with salt water to make a lower grade product. Sometimes this is followed by extraction with boiling brine. The yield is typically about 90 per cent of fish sauce by weight. The chemical composition of low grade and high grade nam-pla (Thailand) is given in the table below.**

	<b>Low grade</b>	<b>High grade</b>
Salt (g/100cm <sup>3</sup> )	28.4	28.15
Total nitrogen (g/100cm <sup>3</sup> )	0.92	1.92
Ammonia nitrogen (g/100cm <sup>3</sup> )	0.28	0.28
TMA nitrogen (g/100cm <sup>3</sup> )	0.02	-
Organic nitrogen (g/100cm <sup>3</sup> )	0.62	0.64
Formol nitrogen (g/100cm <sup>3</sup> )	0.83	1.13
Amino nitrogen (g/100cm <sup>3</sup> )	0.55	0.85
pH	5.75	5.58



Source: Redrawn from Figure 19 in Food and Agriculture Organization of the United Nations Regional Office for Asia and the Far East, Bangkok (1967). *Indo Pacific Fisheries Council Regional Studies No 4, Fish processing in the Indo-Pacific area*, compiled by G. N. Subba Rao.

**Figure 2 - Vietnam: General view of a nuoc-mam vat at Nha-Trang (Courtesy Institut Oceanographique de Nha-Trang)**

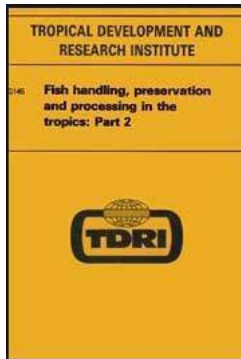
**A first-grade product should contain 20 - 23 g/litre of nitrogen and, of this, 50 per cent**

should be formol titratable and not more than 15 - 20 per cent titratable as ammonia. The salt content should be 20 - 25 g/100 g and the pH should be below 6.0.

A good deal of research has been undertaken in an effort to speed up the process of manufacture of fish sauces. The process proceeds faster as the temperature increases up to about 45°C; unfortunately, the liquids that are produced at such high temperatures do not have the characteristic flavour of the classic sauces. This fact is well known amongst the producers who endeavour to keep the areas in which the vats are situated relatively cool. Although some work has been carried out on the flavouring substances of fish sauces, no accelerated process has so far been brought into commercial use.



[Home](#) > [ar.cn.de.en.es.fr.id.it.ph.po.ru.sw](#)



## **Fish Handling, Preservation and Processing in the Tropics: Part 2 (NRI)**

 ***(introduction...)***

 **Summaries**

 **Acknowledgements**

 **Introduction**

 **Salting of fish: salt**

 **Salting of fish: methods**

 **Drying of fish: basic principles**

 **Drying of fish: methods**

 **Smoking of fish**

 **Marinades**

-  **Fermented fish products: a review**
- ➔  **Boiled fish products**
-  **Fish canning: theory and practice**
-  **Freeze drying**
-  **Irradiation**
-  **Miscellaneous products: crustaceans**
-  **Miscellaneous aquatic products used as food**
-  **Food by-products**
-  **Non-food by-products**
-  **New and delicatessen products**
-  **Fish meal**
-  **Fish silage**
-  **Chemical and physical methods of quality assessment**
-  **Organoleptic (sensory) measurement of spoilage**
-  **Microbiology of spoilage**
-  **Microbiology of fish spoilage**
-  **Public health microbiology**
-  **International standards for fisheries products**
  
-  **Large-scale fish landing facilities**
-  **Small-scale landing facilities: design and operation**
-  **Retail sale facilities**
-  **Fisheries extension services: their role in rural development**
-  **Training in the field**
-  **Appendix**

## **Boiled fish products**

**Boiling fish in water is a method of short-term preservation used in many countries especially in South East Asia; although the method is used in other parts of the world, it is in fact only of major commercial significance in South East Asia. The shelf life of the products varies from one or two days to several months depending on the method of processing.**

### **Basic method**

**The action of boiling fish in water at normal temperatures and pressures denatures (cooks) the proteins and enzymes and kills many of the bacteria present on the fish. The normal spoilage that occurs in a dead fish is thus stopped or drastically reduced. With the normal methods of packaging which are employed with cooked fish, they are very soon contaminated with bacteria again and spoilage can thus begin. Boiling fish in water will not produce a completely sterile product and, even if they were packed in completely sealed packaging, spoilage would still occur.**

**Very many variations of the basic method of preparation are used, depending on the raw material available, the required shelf life and consumer preferences. Often salt is added before, during or after processing; high levels of salt in the final product will help to extend the shelf life. In hot humid countries, therefore, where drying fish may be difficult, boiling may allow distribution of the catch to market in an acceptable condition with simple, low-cost facilities and equipment.**

**Products where the fish are boiled for a relatively short time with little salt should be treated in the same way as fresh fish. Where fish are cooked for several hours with plenty of salt, the product will not resemble fresh fish and can be treated in a similar manner to other salted fish products.**

## Variety of production methods in Asia

**Some idea of the range of boiled fish products produced in Asia is given from the outline of methods below.**

### Cambodia

**Raw material: Eleutheronema, Stromateus, Polynemus, Cybium, Sardinella spp.**

**Processing method: Immerse the fish in boiling brine (5 kg NaCl per 20 litres sea water) for 3 minutes. The fish are boiled in small baskets which are used both for cooking and distribution.**

**Storage life: 1-3 days.**

### Malaysia

**Raw material: Rastrelliger sp. (kembung)**

Processing method:	1 Wash the fish in sea water.
	2 Immerse them in saturated brine for 3 - 4 hours.
	3 Arrange the salted fish in bamboo baskets.
	4 Immerse the baskets in boiling brine containing 25 - 34 per cent salt.
	5 Allow the baskets to cool.
	6 Store in a cold room.

**Yield: Approximately 70 per cent of raw material weight.**

**Packaging: The processing baskets.**



## The Philippines

### Raw material: Tulingan, frigate mackerel etc.

Processing method:	1 Prepare the fish. They may or may not be gutted; the side of the fish may be cut.
	2 Rub salt into the fish.
	3 Place the fish on a mat in a clay pot.
	4 Fill to the top of the pot with fish.
	5 Heat the pot gently until the fish are steamed.

### Packaging: The processing pot.

## Indonesia

In Indonesia, various boiled fish products are produced, generally known as pindang. One of the methods used is as follows:

**Raw material: Many species, including sharks, but commonly Rastrelliger (kembung), Decapterus (lejang), Euthynnus (tonkol) and Caranx spp.**

Processing method:	1 Gut and cut the fish to fit the container; small fish may not be gutted.
	2 Wash.
	3 Arrange the fish in the containers (clay pots or metal bowls) in alternating layers of fish and salt; the ratio of fish to salt varies between 20:1 and 3:1 depending on the shelf life and taste required.
	4 Add a little water.

	5 Heat above a fire (wood or oil) until nearly cooked.
	6 Drain most of the liquid from the bottom of the container.
	7 Add more salt to fish on the surface and cook until no free water remains in the bottom of the container.
	8 Seal the top of the container with leaves or paper.

**Yield: 80 - 90 per cent of raw material weight.**

**Packaging: The product is distributed in the processing container.**

**Shelf life: May be from a few days to 3 months depending on the quantity of salt and effectiveness of sealing the container.**

**Chemical composition: For Caranx leptolepis,**

Moisture	66.5	per cent
Protein	22.3	per cent
Fat	2.5	per cent
Salt	0.9	per cent

**Research: Some investigation has been undertaken into sterilising the clay pots before cooking. Rubber rings have also been used to seal the top of the container and wax has been used to coat the outside of the pot to seal it: the shelf life may then be extended up to 9 months.**

**Some concern has been expressed in Indonesia over the public health and safety of boiled fish and some cases of sickness, or even death, have been allegedly caused by eating pindang. Traditionally, clay pots have been used for cooking and distribution but recently**

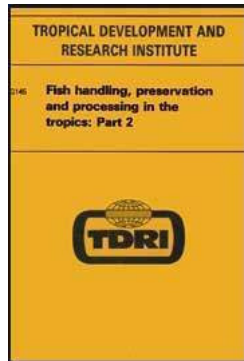
these have been replaced, to some extent, by pots made from galvanised sheet. It has been suggested that the zinc of the galvanising may contaminate the fish, and also there may be contamination from the lead used to solder the seams. In addition, insufficient cooking or too little salt allows the growth of harmful micro-organisms. Although some work has been carried out to extend the shelf life of pindang, it has been proposed that a detailed study of processing, packaging, storage and spoilage is needed.

## Conclusion

Boiled products are acceptable to large numbers of consumers in South East Asia and the process used may be suitable for introduction to other tropical countries where conditions of high temperature and humidity make normal salting and sun drying difficult for part or all of the year.



[Home](#) > [ar.cn.de.en.es.fr.id.it.ph.po.ru.sw](#)



## **Fish Handling, Preservation and Processing in the Tropics: Part 2 (NRI)**

 ***(introduction...)***

 **Summaries**

 **Acknowledgements**

 **Introduction**

 **Salting of fish: salt**

 **Salting of fish: methods**

 **Drying of fish: basic principles**

 **Drying of fish: methods**

-  **Smoking of fish**
-  **Marinades**
-  **Fermented fish products: a review**
-  **Boiled fish products**
-  **Fish canning: theory and practice**
-  **Freeze drying**
-  **Irradiation**
-  **Miscellaneous products: crustaceans**
-  **Miscellaneous aquatic products used as food**
-  **Food by-products**
-  **Non-food by-products**
-  **New and delicatessen products**
-  **Fish meal**
-  **Fish silage**
-  **Chemical and physical methods of quality assessment**
-  **Organoleptic (sensory) measurement of spoilage**
-  **Microbiology of spoilage**
-  **Microbiology of fish spoilage**
-  **Public health microbiology**
-  **International standards for fisheries products**
-  **Large-scale fish landing facilities**
-  **Small-scale landing facilities: design and operation**
-  **Retail sale facilities**
-  **Fisheries extension services: their role in rural development**
- 

## **Training in the field**

### **Fish canning: theory and practice**

**Canning is a relatively modern technology which enables man to preserve food in an edible condition under a wide range of storage conditions for long periods - from a few months to several years. Essentially, the process involves hermetically sealing the food in a container, heat 'sterilising' the sealed unit and cooling it to ambient temperature for subsequent storage.**

#### **Filling and sealing**

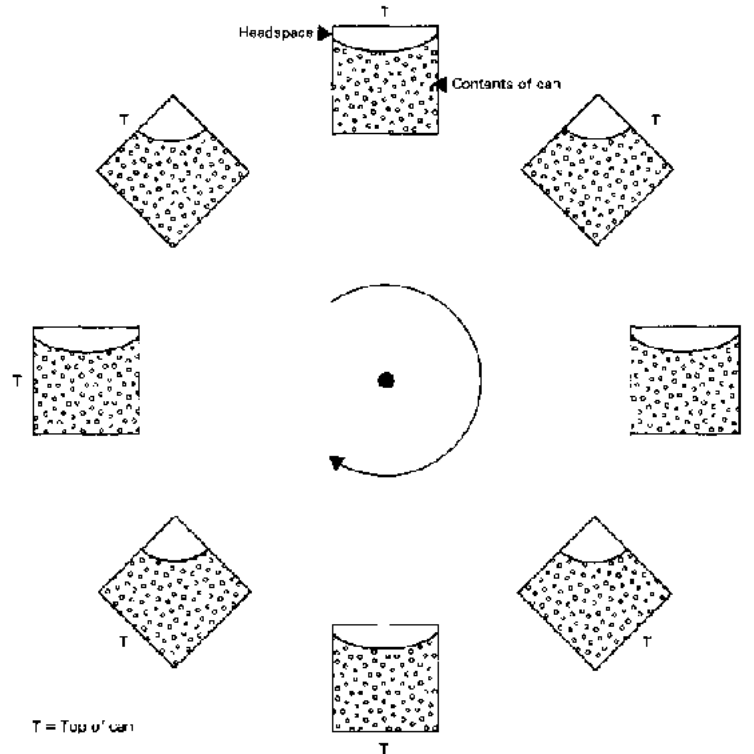
**Fish, being a physically delicate food and, therefore, easily damaged and fragmented by mechanical handling operations, are still largely packed into cans or other retortable containers by hand, with brine, edible oil or sauce which may be metered in mechanically. Often, the fish, after the usual heading, gutting, cleaning and trimming operations, are subjected to pre-processing operations such as salting, brining, drying, smoking, cooking or a combination of these. Such pre-processing operations have the advantages of:**

- (a) denaturing the proteins and thus rendering the fish muscle firmer and more capable of withstanding handling during the filling operation; and**
- (b) removing water from the fish making them less subject to shrinkage and unsightly aqueous exudation inside the can during heat treatment.**

**Canned fish is famous for the way it is packed so tightly within the container, leaving very little space for additional liquids.**

**Heat transfer through the fish is by conduction and, therefore, very slow; at a processing temperature of 121°C, it would take 6 hours to raise the centre temperature of a 145.5 mm**

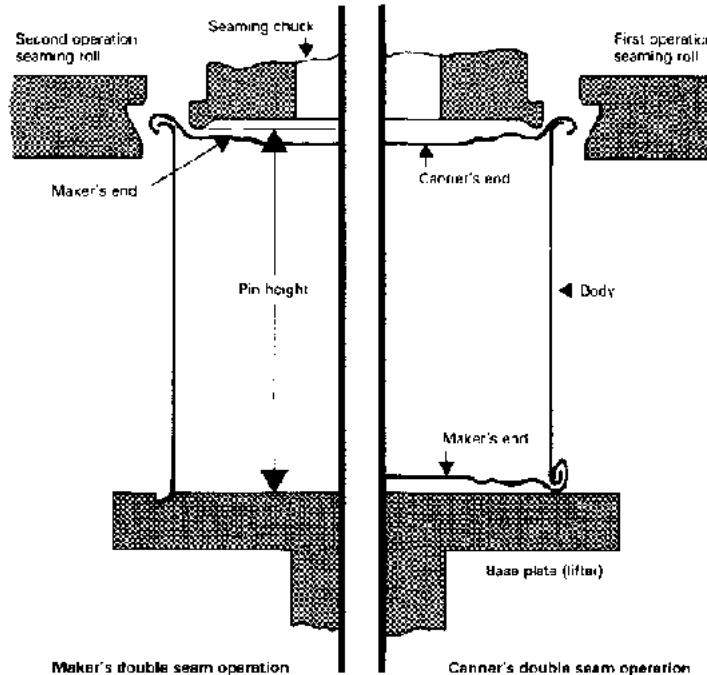
**(diameter) by 168 mm (height) can from 10 to 100°C by conduction alone. In this time, the fish nearest the walls of the container would be grossly overcooked. By comparison, if all the heat could be transferred by convection, in the same size can under the same conditions, it would only take 20 minutes to achieve the same temperature rise at the can centre. Obviously, it is best to have the fish surrounded by liquid so that the distance through which heat is transferred by conduction is kept to a minimum. Most fish canners increase in-can heat transfer rates even further by processing the cans in a rotary retort. The movement of the headspace bubble during rotation forces an increase in liquid movement and, therefore, convection heat transfer. The fish are more evenly cooked throughout the can and, those nearest the can walls are less likely to be overcooked (See Figure 3).**



**Figure 3 - Movement of headspace in rotary retort**

**The headspace (or ullage) is the space left in the top of the can to allow for expansion of the contents during the heating process. However, leaving air in this headspace causes considerable internal pressure during processing and leads to oxidation of the contents (surface discoloration and rancidity) and the container (corrosion) during subsequent**

storage. it is, therefore, necessary to seal the can under vacuum (See Figures 4 and 5).



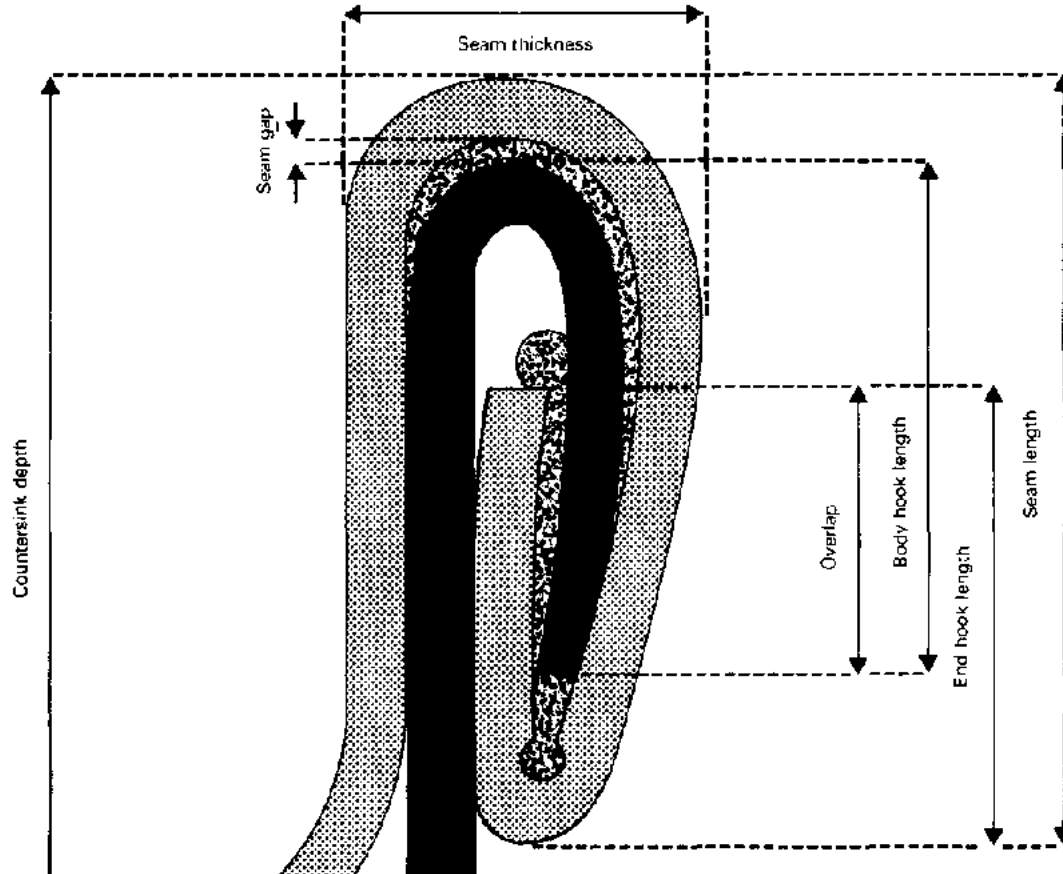
Source: Redrawn from a drawing on page 14 of Double Seam Manual, Metal Box Open Top Group (1978).

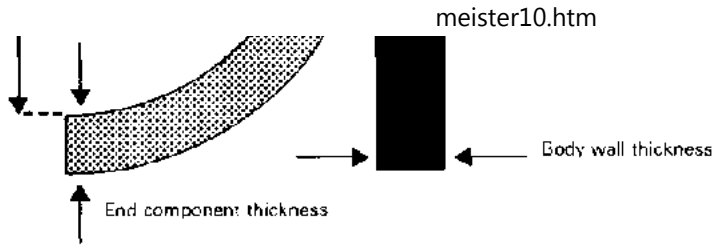
**Figure 4 - Basic seamer design**

The Figures show how the lid (or end) is attached to the body of the can in the two **DOUBLE-SEAMING** operations. It is vitally important that the side seam and the double seams are completely hermetic. The former uses solder (98 parts lead: 2 parts tin) to



complete the seal whilst the latter is sealed by the melting and resetting of a plastic sealing compound on the inside curl of the end-piece (See Figure 5).





Source: Redrawn from a drawing on page 8 of 'Double Seam Manual', Metal Box Open Top Group (1978).

**Figure 5 - Double seam dimensional terminology**

**It is important that double seams are checked regularly both for visible faults and, by measurement for slackness, for the extent to which the body hook penetrates the sealing compound in the curl of the end-piece.**

### **Sterilisation**

**Not all fish which are sealed into cans are heat processed. Anchovies, for example, are packed in salt and then sealed in cans without any further processing: the very high salt content prevents subsequent growth of micro-organisms. However, the product can only be eaten in very small quantities in this form and is generally used as a condiment or flavouring in other dishes.**

**If heat sterilisation is to be the method of preservation, it is essential that the effect of severe heat treatment on the fish tissues is known.**

**Firstly, it is impossible to produce a high quality canned fish product from fish which are at an advanced stage of spoilage.**

**Secondly, as the temperature rises, the muscle proteins become increasingly denatured and progressively lose the water which is loosely bound in the undenatured protein**

**network. The watery exudate is unsightly and may cause a sauce to curdle whilst the partially dehydrated fish muscle, although surrounded by liquid, has a dry 'woolly' feel in the mouth. Besides this denaturation, the severe heat treatment may cause some degradation of proteins to amino acids and other simple (but often malodorous) breakdown products which may also react with the metal of the can walls, producing unsightly black deposits.**

**The quality of oily fish is much less impaired by the severe heat process than that of non-oily fish, which generally yield a product only suitable for fish paste or pet food manufacture. This may merely be a physical effect of the oil in the muscle tissue acting as a barrier to water loss from the protein structures, so enabling canned oily fish to retain their succulence through the heat process.**

**For the purpose of determining the degree of heat treatment which is needed to preserve food within a can, three pH groupings are recognised:**

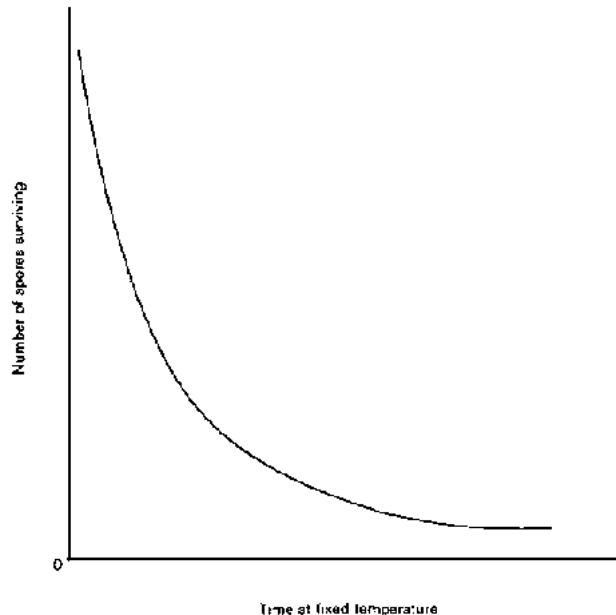
**(i) Acid foods at less than pH 4.5 cannot support the growth of heat-resistant spore forming pathogens like Clostridium botulinum. To effectively preserve such foods (e.g. most fruits and pickles), it is necessary only to destroy the relatively heat sensitive acid tolerant microorganisms which could otherwise grow and cause spoilage. A mild heat process (e.g. the coldest point in the can should receive a minimum process of 5 minutes at 100°C) only is required.**

**(ii) Medium-low acid foods between pH 4.5 and 5.3 will support the growth of pathogenic heat-resistant spore formers like C. botulinum and must, therefore, be processed to reduce the chance of such a spore surviving to virtual insignificance (e.g. the coldest point in the can should receive a minimum process of 10 minutes at 121°C).**

**(iii) Low acid foods with a pH greater than 5.3 will support the growth of organisms like C. botulinum, as well as the germination and growth of highly heat-resistant spores like**

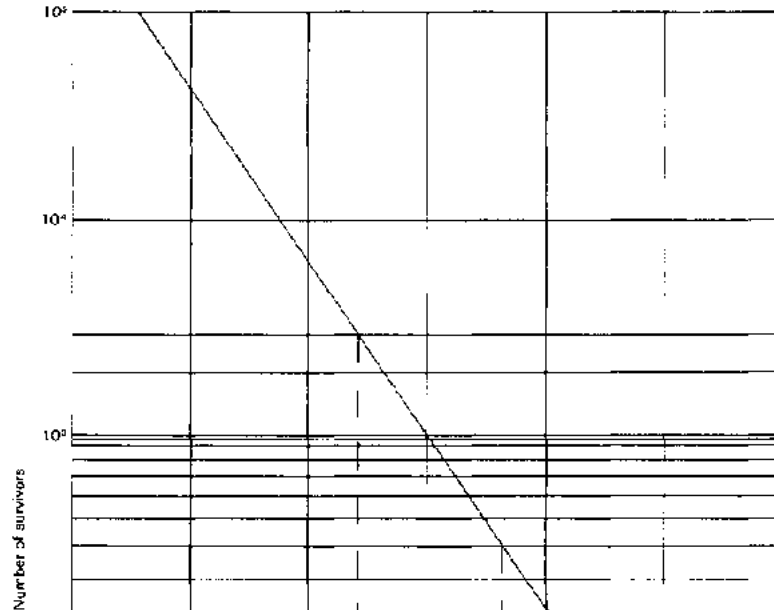
those of *Bacillus stearothermophilus* which cause flat-sour spoilage. Fortunately, these organisms will only germinate and grow at temperatures greater than 37°C because, if it were deemed necessary to heat process to destroy them, the severity of the process would probably render the food inedible.

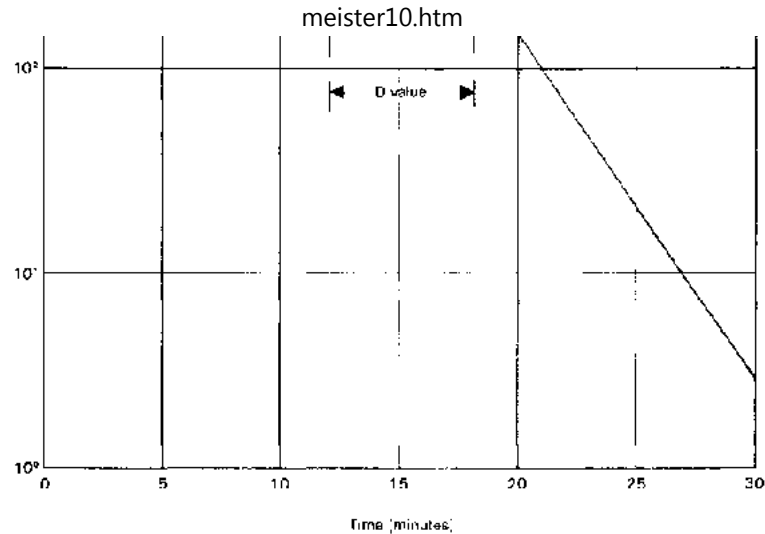
Fish are a low acid food and it should, therefore, be remembered that canned fish which have been processed to eliminate the chance of *C. botulinum* spore survival should be stored at temperatures below that at which possible surviving spores of *B. stearothermophilus* could germinate.



## Figure 6 - Thermal death curve for hypothetical organism

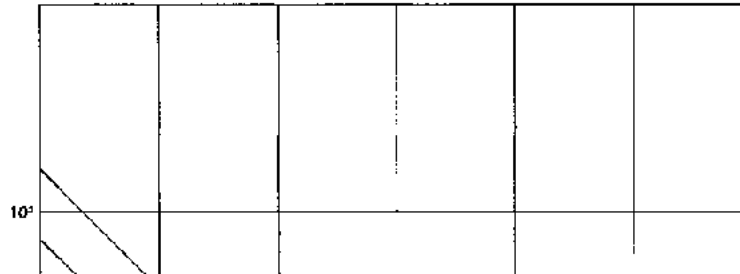
Figure 6 is a thermal death curve showing the number of surviving spores against time at a given process temperature. Figure 7 is a death rate curve and shows the log<sub>10</sub> number of surviving spores against time at a given process temperature. These figures show that the destruction of bacterial spores at a given process temperature is not instantaneous but decreases logarithmically with the exposure time to that temperature. The time taken for the graph to traverse one log cycle (i.e. the time taken at a given temperature to reduce a particular bacterial spore population to one tenth of its original number) is called the Decimal Reduction Time, D(O) (O being the given temperature).

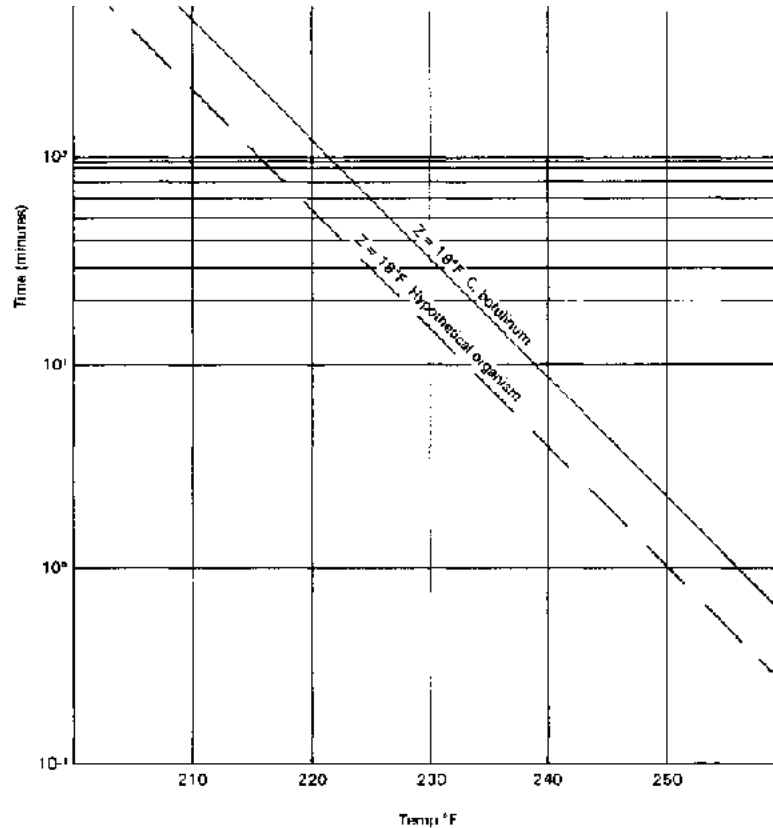




**Figure 7 - Death rate curve**

**Figure 8 is a thermal death time curve and it shows the Decimal Reduction Time against the process temperature. From this figure, the temperature interval over which a ten-fold increase or decrease in the value of  $D(0)$  occurs is called the Z value.**





Source: Adapted from a drawing on page 179 in "Canned Foods", by A. C. Hester and E. D. Hullard. Churchill Livingstone, Edinburgh, Scotland (7th Edition, 1980).

**Figure 8 - Thermal death time curve**

**Most fish canning heat processes are based on the elimination of *C. botulinum* spores, which is reasonable since this is the most heat-resistant pathogen which could grow in the canned fish. However, it can be seen from Table 1 that a process achieving 12 decimal reductions of *C. botulinum* spores (i.e.  $12 \times 0.2 = 2.4$  minutes at  $121^\circ\text{C}$ ) would only achieve approximately half a decimal reduction of *B. stearothermophilus* spores.**

<i>Organisms</i>	$D_{121^\circ\text{C}}$ (minutes)
<b>Thermophiles:</b>	
<i>B. stearothermophilus</i> spores	4 – 5
<i>C. thermosaccharolyticum</i> spores	3 – 4
<i>C. nigrificans</i> spores	2 – 3
<b>Mesophiles:</b>	
<i>C. botulinum</i> spores (types A & B)	0.1 – 0.2
<i>B. coagulans</i> spores	0.01 – 0.07
<b>Non-spore forming mesophilic bacteria, yeast and moulds</b>	
	$D_{86^\circ\text{C}}$ (minutes) 0.5 – 1.0

**Table 1 Bacterial groups and their heat resistance**

**Obviously it is not possible to achieve a 'cold spot' temperature instantaneously. The temperature at the cold spot rises slowly throughout the process which may use a temperature below  $121^\circ\text{C}$  anyway. It is therefore necessary to know the 'lethality' of all temperatures with respect to the lethality of 1 minute at  $121^\circ\text{C}$ . For this we use the reciprocal of D called L value or 'lethal rate'.**

<i>Cold spot temperature (<math>^\circ\text{C}</math>)</i>	<i>D value</i>	<i>L value</i>
131	0.1	10
121	1.0	1
111	10.0	0.1
101	100.0	0.01
91	1000.0	0.001

(In this case,  $Z = 10^\circ\text{C}$  as for *C. botulinum* spores.)



**Table 2**

**So, in this example, it takes 1000 minutes at 91°C to achieve the same killing effect on bacteria as 1 minute at 121°C: or 1 minute at 91°C has 1/1000 the lethal effect of 1 minute at 121°C.**

**If the initial concentration of bacterial spores is N1, which must be reduced in number to an acceptable level, No, the quantity  $\log N1/N0$  is called the 'Order of Process Factor'**

**Thus, if Nf is the number of spores surviving after processing**  
 $\log Nf/N1 = \log N0/N1$

**to ensure commercial sterility.**

**This can be expressed as follows:**

$$\int_0^{t_f} L dt \geq mD\theta$$

**where**

<b>L</b>	is the L value for the related temperature occurring during the process lasting from time 0 to time $t_f$ ,
<b>m</b>	is the order of process factor for commercial sterility, and
<b>D</b>	is the decimal reduction time for the spoilage organism under consideration at the reference temperature.

**L values are available from tables or may be calculated from**

$$L = 10^{\frac{T - \theta}{Z}}$$

**where T is the related temperature.**

**Once the temperature history of the process of a canned food has been plotted and the main spoilage organism identified and its Z value found, a graph of L versus time of processing may be plotted throughout the process. The area beneath this graph must exceed mD for commercial sterility. This value has been called the 'equivalent time' and is the F value.**

**Packs with pH 4.5 are generally processed to commercial sterility with reference to C. botulinum, the minimum order of process factor 'm' being taken as 12. Thus, mD( $\theta$ ) should be  $12 \times 0.3 = 3.6$  minutes at  $121^\circ\text{C}$  at the cold spot.**

**However, in different foods, there are often spoilage organisms with more heat labile spores than C. botulinum (See Table 3).**

Spoilage organism	Type of spoilage	Process temperature °C	D <sub>β</sub> (minutes)	Z value °C	m	Type of product needing protection against spoilage by this organism
<i>C. botulinum</i> types A and B	Putrid swell	121	0.1–0.3	8.0–11.0	12	Low acid food pH 4.5
<i>C. sporogenes</i>	Putrid swell	121	0.8–1.5	9.0–11.0	5	Meats
<i>B. stearothermophilus</i>	Flat sour	121	4.0–5.0	9.5–10.0	5	Vegetables and milk
<i>C. thermosaccharolyticum</i>	Hard swell	121	3.0–4.0	7.0–10.5	5	Vegetables
<i>B. subtilis</i>	Hard swell	121	0.4	6.5	6	Milk products
<i>B. coagulans</i>	Acidic	121	0.01–0.07	10.0	5	Foods of pH 4.2–4.5, e.g., tomatoes
<i>C. pasteurianum</i>	Butyric	100	0.1–0.5	8.0	5	Foods of pH 4.2–4.5, e.g., pears
<i>C. nigrificans</i>	Sulphur stinkers	–	2.0–3.0			Sugars and starch

Table 3

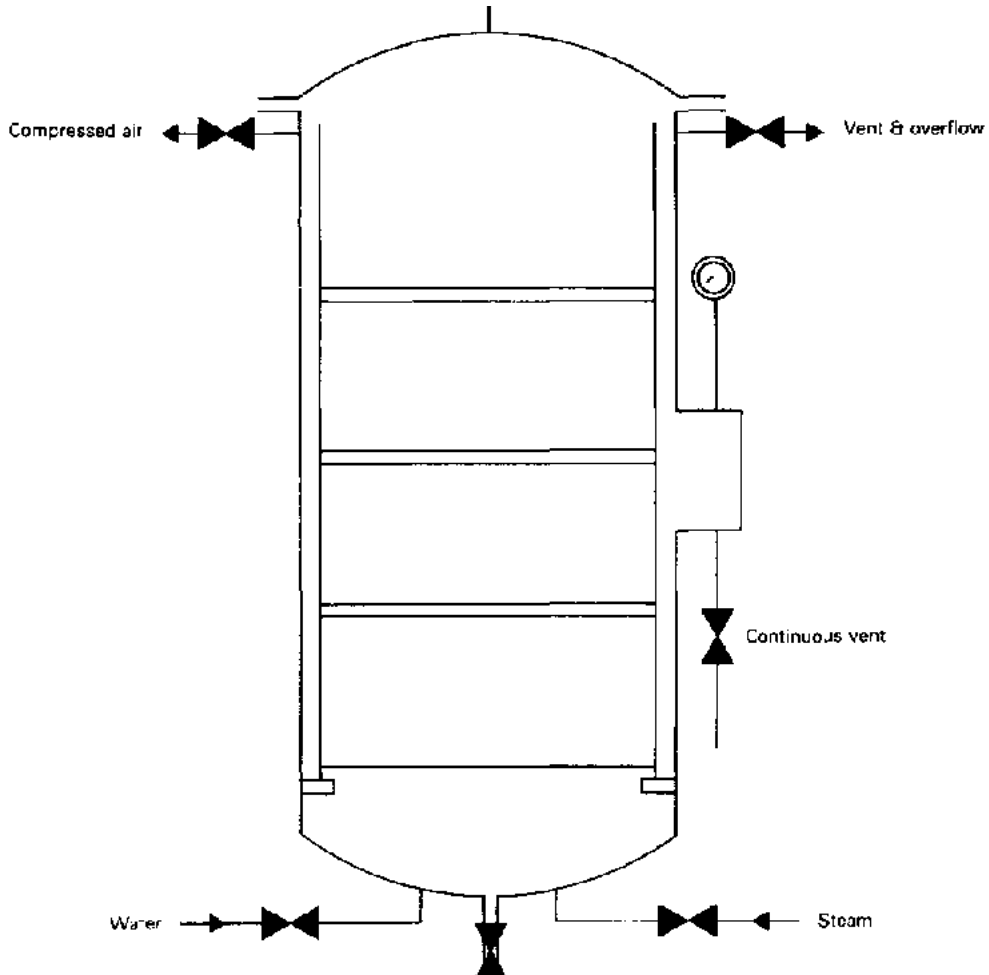
### Sterilisation equipment (See Figure 9)

To achieve processing temperatures above 100°C, condensing steam under pressure is used in most conventional systems, although other processing media include gas flames, steam and air mixtures and even hot fluidised sand.

After the cans are sealed in the retort, steam is admitted and the temperature of the retort allowed to rise to 100°C and maintained at this temperature until all air is flushed out of the retort. Air pockets left in the retort can lead to localised under-processing, as air insulates any cans it may surround from the steam.



Continuous vent





Drain

**Source:** Simplified from a drawing on page 208 of 'Food Engineering Operations', by J. G. Brennan, J. R. Butters, N. D. Cowell and A. E. V. Lilly. Applied Science Publishers Ltd., London (2nd Edition, 1976).

### **Figure 9 - Static vertical retort**

**Pressure is applied by closing off the drain and steam exit valves whilst still allowing steam into the retort. Various petcocks are left open to allow any air, which may be admitted with the steam, to escape. Common processing temperatures are 115.5°C and 121°C. The pressure, and hence the retort temperature, is controlled by an automatic steam pressure control valve; this opens when the set pressure is exceeded and closes again when the pressure falls below that set.**

### **Cooling**

**The pressure in the retort is maintained after closing the steam inlet valve by admitting compressed air to the retort. If this were not done, the large pressure inside the can compared with the low pressure inside the retort would cause the cans to distort outwards ('peaking'), possibly damaging the integrity of the seams. As the retort pressure is being maintained with the compressed air, chlorinated cooling water is admitted to the retort.**

**The cooling water is chlorinated because, at this stage, the sealing compound in the double seams is still molten and the vacuum forming in the headspace due to condensing steam could pull drops of cooling water through the double seam. If this cooling water contains viable micro-organisms, this leakage may lead to 'leaker spoilage'. This type of spoilage is by far the most common that is implicated in food poisoning attributed to canned food. Cooling water is generally recirculated and dosed automatically with**

**chlorine. A residence time of at least 20 minutes between dosing and utilisation for can cooling is necessary to allow the free residual chlorine responsible for the bactericidal effect to accumulate. The free residual chlorine content of the cooling water should be measured in water draining from the retort rather than in that entering the retort. Common chlorination levels lead to 5 - 20 ppm free residual chlorine in the drain water. Too high chlorination levels can lead to can corrosion problems.**

**As cooling proceeds, it becomes necessary to reduce compressed air pressure in the retort since the pressure inside the can falls with the temperature of its contents, eventually becoming a partial vacuum. If, then, the pressure outside the can far exceeds the pressure inside, the can may buckle inwards ('panelling') which could also damage the can seam.**

**When the cooling process has been completed (the can contents having reached a sufficiently low temperature and the retort pressure having been reduced to atmospheric), the retort is opened and the wet cans lifted out. It is essential that the wet cans are not handled at this stage: the danger of contaminating the can contents via a leaking seam still exists. Cans should be conveyed mechanically to a can drier along chlorinated runways before they are labelled and packed into cases or shrink-wrapped.**

**Other special problems related to fish canning**

**Can lacquers**

**Fish proteins, and especially crustacean and shellfish proteins, are rich in sulphur amino acids which, on heat processing, release hydrogen sulphide. This can react with iron in the tinplate producing black ferrous sulphide ('sulphur staining'). To avoid these unsightly black deposits, a special lacquer incorporating zinc oxide or zinc carbonate is used to coat the internal can walls. The hydrogen sulphide released now reacts preferentially with the zinc oxide or carbonate producing white zinc sulphide which remains embedded in the lacquer so that an attractive internal appearance is maintained.**

## **Struvite**

**In some canned fish products, glass-like crystals of calcium struvite may form on storage and become the reason for many 'foreign body' complaints in canned fish. This phenomenon may be avoided by the addition of small amounts of citric acid to the product prior to filling and processing. Citric acid complexes available calcium ions, thus preventing them from forming calcium struvite.**

## **Conclusion**

**In conclusion, it should be noted that, although fish may be canned to provide an excellent long shelf life product, which in the case of some canned oily fish products like sardines and pilchards is said to improve with keeping, setting up a commercial canning operation involves extremely high capital expenditure. Also in the case of fish canneries, the method of packing the fish in cans makes the operation highly labour intensive.**

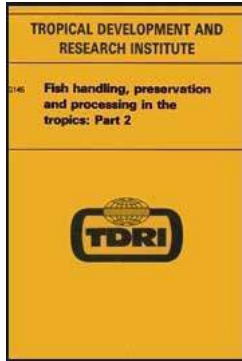
**The canning line should be designed so that the retorts, can driers, and labelling and packing sections are well removed from the raw fish handling sections because of the danger of leaker contamination.**

**Quality inspection of raw materials, can seams and cooling water chlorination levels at regular intervals is essential but it is also normal quality control practice to hold back samples of cans from each retort batch for incubation tests - this means that canned products should carry some device which enables their production batch to be identified.**

**In general, it may be said that good quality canned fish products can only be made from good quality, clean fish. White fleshed fish tend not to make good canned products whatever their quality: the heat process makes a dry, discoloured product which falls apart.**



[Home](#) > [ar.cn.de.en.es.fr.id.it.ph.po.ru.sw](#)



## **Fish Handling, Preservation and Processing in the Tropics: Part 2 (NRI)**

 **(introduction...)**

 **Summaries**

 **Acknowledgements**

 **Introduction**

 **Salting of fish: salt**

 **Salting of fish: methods**

 **Drying of fish: basic principles**

 **Drying of fish: methods**

 **Smoking of fish**

 **Marinades**

 **Fermented fish products: a review**

 **Boiled fish products**

 **Fish canning: theory and practice**

  **Freeze drying**

 **Irradiation**

 **Miscellaneous products: crustaceans**






 **Miscellaneous aquatic products used as food**

 **Food by-products**

 **Non-food by-products**





-  **New and delicatessen products**
-  **Fish meal**
-  **Fish silage**
-  **Chemical and physical methods of quality assessment**
-  **Organoleptic (sensory) measurement of spoilage**
-  **Microbiology of spoilage**
-  **Microbiology of fish spoilage**
-  **Public health microbiology**
-  **International standards for fisheries products**
-  **Large-scale fish landing facilities**
-  **Small-scale landing facilities: design and operation**
-  **Retail sale facilities**
-  **Fisheries extension services: their role in rural development**
-  **Training in the field**
-  **Appendix**

## Freeze drying

The boiling point of water depends on pressure - at atmospheric pressure, 1 bar, it boils at 100°C.

If water is held in a sealed container in which we can draw a vacuum, the lower the pressure or the better the vacuum, the lower the temperature at which the water boils but more heat is needed to evaporate 1 kg of water:

Pressure (bar)	Temperature (° C)	Latent heat of vaporisation (kJ/kg)
1.0	100	2257
0.5	91	2305

0.2	60	2358
0.1	46	2392
0.01	7	2485

**At a pressure of about 0.006 bars, the boiling point of water is 0°C. The latent heat would be 2500 kJ/kg but, in evaporating, the water would take some of the heat from itself causing that remaining to freeze (this releases 334 kJ/kg), leaving ice at 0°C. If the vacuum is maintained at about 0.006 bars, the ice will sublime, that is, not melt but go straight to water vapour. As long as heat is available, the latent heat of sublimation at 0°C is 2834 kJ/kg.**

**In the same way as the boiling point is depressed by improving the vacuum, so taking the pressure below 0.006 bars will depress the sublimation temperature below 0°C:**

Pressure (bar)	Temperature (°C)	Latent heat of sublimation (kJ/kg)
0.0060	0	2834
0.0026	- 10	2836
0.0010	- 20	2837
0 0004	- 30	2838
0.0001	- 40	2838

**When a pot of water is being heated at atmospheric pressure, it will boil at 100°C whatever the temperature of the flame. In the same way, ice at a pressure of 0.0001 bar will sublime at - 40°C, as long as the water vapour can escape, whatever the temperature of the source of heat. If the water vapour cannot escape the pressure will quickly increase and the sublimation temperature will rise in proportion until, at a pressure of 0.006 bars,**

**the ice will start to melt.**

## **The process of freeze drying**

**Developing the above principles, the freeze drying process involves:**

- 1. Placing the food in a chamber which is then sealed, after which a vacuum is drawn so that the pressure is well below 0.006 bars (probably below 0.001 bars).**
- 2. The temperature of the food is above the sublimation temperature and so, in cooling down and freezing, it supplies some heat for water to evaporate and then sublime (this is the same as evaporative cooling).**
- 3. Once the food is at the sublimation temperature which corresponds with the pressure, heat is somehow supplied to the food to provide the latent heat of sublimation so that the frozen water sublimates to water vapour.**
- 4. The water vapour is drawn out of the chamber by the vacuum system, thus maintaining the low pressure in the chamber until all the frozen water has sublimed, leaving the dried food.**

**The dried food does NOT need to be stored under refrigeration since it contains no water needing to be kept frozen in order to prevent microbial growth. The dried food DOES need to be well packed, however, probably in aluminium foil laminates, to prevent the food from reabsorbing moisture from the air; it may perhaps be packed in a vacuum or inert gas to prevent, otherwise rapid, oxidative deterioration. If the food has been previously frozen, stage 2 does not apply.**

## **Advantages**

- (a) No shrinkage - the freezing of the food effectively fixes its shape.**
- (b) No case hardening - there is no water movement to carry solubles to the surface; the ice directly sublimates from within the food as the drying front penetrates.**
- (c) No thermal damage - no high temperatures to cause loss of flavour or development of 'burnt' flavours.**
- (d) Rapid rehydration - because a very open texture is obtained.**

### **Disadvantages**

**These all relate to the economy of the process and the storage and distribution of the end product.**

- (a) Primary cost. - The equipment is sophisticated and expensive.**
  - The chamber (which is required by any mechanical drying method) has to be very strong: it must be capable of withstanding the pressure differences. The seals on the door must be airtight to ensure that low pressures are easily maintained.**
  - The low pressure required necessitates sophisticated vacuum equipment, steam ejectors and/or heavy duty piston pumps. If the latter are used, a vapour removal system is required between chamber and pumps.**
  - Some system is required to provide heat to the food during the drying process.**
  - To maximise the capacity of the system, it may be desirable to freeze the product before drawing a vacuum, either within the chamber or in a separate process.**
- (b) Operating costs. - In addition to the energy of evaporation (which is required by all**

**drying processes), energy is required to develop and maintain the vacuum and for any refrigeration facility (to pre-freeze and perhaps to recondense vapour to stop it getting through to a piston vacuum pump).**

**- A high level of competence is required in operators and service engineers: there is, therefore, a relatively high labour cost.**

**- The technology is advanced: therefore, repair and maintenance costs (spares) are high, compared to more conventional drying systems.**

**- It is a batch process: there are periods of loading/unloading when equipment is unoperational.**

**(c) End product.**

**The high prime and operating costs mean that this process is only suitable for high value foods which can carry a high production cost. However, the consumer expects good quality from high cost goods.**

**- The lack of shrinkage and case hardening associated with a very low moisture content means that freeze dried foods are very brittle and so need to be protected by rigid packaging.**

**- The open structure and low water content mean that freeze dried foods are very vulnerable to oxidative deterioration and so, as already mentioned, gas tight packaging associated with inert gas purging is often adopted.**

**Therefore, expensive packaging is the norm.**

**Accelerated freeze drying (AFD)**

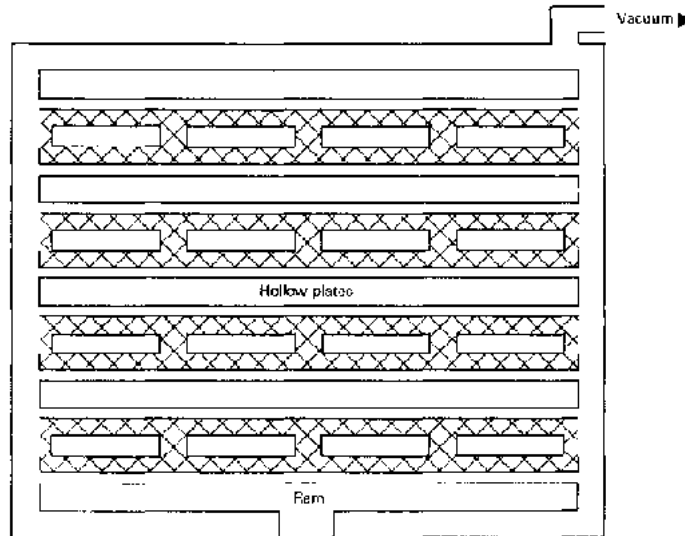
**Although freeze drying takes no longer, and is often faster, than more conventional systems, attempts have been made to accelerate the process in order to reduce production costs and increase the capacity of the process. The limiting factor is the transference of heat to the food: convection is impossible in a vacuum. Therefore, radiant heat, a relatively inefficient method is used.**

**A technique for accelerating the drying process for slabs of food or relatively uniform particles of food (e.g. whole prawns) has been developed and commercially adopted. The food is arranged in single layers between expanded metal mesh, held in a tray and covered by a sheet of stainless steel or aluminium (See Figure 10). This sandwich is placed between hollow plates in the chamber (See Figure 11).**



**Figure 10 - Food and metal grid arrangement for AFD process**

**Once the chamber is at the required pressure and the food is at the sublimation temperature, fluid contained within the hollow plates is heated to a temperature between 60 and 100°C. The heat is conducted rapidly through the metal sheets/trays and mesh to the food surface allowing rapid sublimation. The mesh is important because the water vapour is allowed to escape into the chamber; this would not be possible if the food was in contact with a continuous metal surface. If the water vapour could not escape, the pressure at the food surface would increase and the food would melt.**



**Figure 11 - Arrangement of food in chamber for AFD process**

**As the sublimation front penetrates the food, the pressure is applied to the plates (generally by a hydraulic ram as indicated in Figure 11) up to a maximum force of about 8 Ib/in<sup>2</sup>, which causes the mesh to penetrate the surface of the food giving more direct heat conduction to the sublimation front. Simultaneously, the temperature of the heating material is reduced since, after sublimation, the surface temperature of the food will be the same as the heat source.**

**Care has to be taken not to force the mesh beyond the sublimation front because this will cause thawing at the centre. Similarly this process cannot be used for foods containing bone, cartilage or substantial fatty tissue, all of which will conduct heat beyond the sublimation point resulting in thawing.**

**Where the fat is distributed more evenly, as with fatty fish, a lower temperature is used while, with other products, the risk of mechanical damage limits the pressure that can be applied to the plates.**

**Adoption of AFD may halve the process time associated with freeze drying (from 10 - 12 hours to 6 - 7 hours) but this depends very much on the thickness of the food, acceptable temperatures and plate pressures. Current research is attempting to further accelerate heat transfer.**

**Practical investigations often indicate that freeze dried prawns are frequently superior to those frozen individually using liquid nitrogen, and always superior to those frozen by other techniques, but production costs are higher. For fin fish produce, the production cost is too high unless weight and reconstitutability considerations outweigh all others. The end product has to be cooked during or after rehydration and it has been reported that water retention is poor.**

## **Conclusions**

**Freeze drying and accelerated freeze drying are processes which have high capital, running and maintenance costs and are, therefore, limited to high cost and speciality foods. However, when used for such products, superior quality goods are obtained if the process is carefully controlled.**

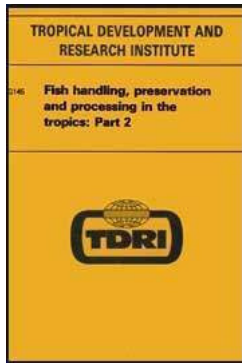







**[Home](#)''' ''''''> [ar.cn.de.en.es.fr.id.it.ph.po.ru.sw](#)**










 **Fish Handling, Preservation and Processing in the Tropics: Part 2  
(NRI)**

 **(introduction...)**





-  **Summaries**
-  **Acknowledgements**
-  **Introduction**
-  **Salting of fish: salt**
-  **Salting of fish: methods**
-  **Drying of fish: basic principles**
-  **Drying of fish: methods**
-  **Smoking of fish**
-  **Marinades**
-  **Fermented fish products: a review**
-  **Boiled fish products**
-  **Fish canning: theory and practice**
-  **Freeze drying**
-   **Irradiation**
-  **Miscellaneous products: crustaceans**
-  **Miscellaneous aquatic products used as food**
-  **Food by-products**
-  **Non-food by-products**
-  **New and delicatessen products**
-  **Fish meal**
-  **Fish silage**
-  **Chemical and physical methods of quality assessment**
-  **Organoleptic (sensory) measurement of spoilage**
-  **Microbiology of spoilage**

-  **Microbiology of fish spoilage**
-  **Public health microbiology**
-  **International standards for fisheries products**
-  **Large-scale fish landing facilities**
-  **Small-scale landing facilities: design and operation**
-  **Retail sale facilities**
-  **Fisheries extension services: their role in rural development**
-  **Training in the field**
-  **Appendix**

## **Irradiation**

### **Possible use in food preservation**

**Ionising irradiation is the only alternative to heat processing for food preservation that has a lethal effect on micro-organisms. Further, it is the only novel method of food preservation suggested for many centuries. It, therefore, lacks the confidence of other systems derived from years of experience. This is rightly so. There have been mistakes in the past and the food processor has a responsibility to the consumer. As a result of this cautious approach, the use of irradiation for treating foods is heavily restricted in most countries, permission having to be sought before irradiated foods are sold to the public.**

**It is obviously desirable that the irradiation process should in no way affect the fitness of the food for human consumption. An important effect of this consideration is that the radioactivity of the foodstuff should not be increased appreciably above its natural level.**

**The two types of radiation considered for use are, therefore:**

**(a) particle or electron beam type: cathode ray and, B-ray (limited energy and poor**

**penetrative power).**

**(b) electromagnetic wave type: X-ray and  $\gamma$ -ray (deeper penetrative power).**

**The high frequency electromagnetic waves, high energy electrons and beams of the heavier atomic particles, being capable of inducing nuclear transformations in the atoms of the target food, are not acceptable.**

### **Energy of radiation**

**Whether particle or wave type radiation is used, its energy is measured in electron volts, eV, or more normally as MeV ( $10^6$ eV)**

**1 eV  $\sim$   $1.6 \times 10^{-12}$  ergs. (1 Joule =  $1 \times 10^6$  ergs.)**

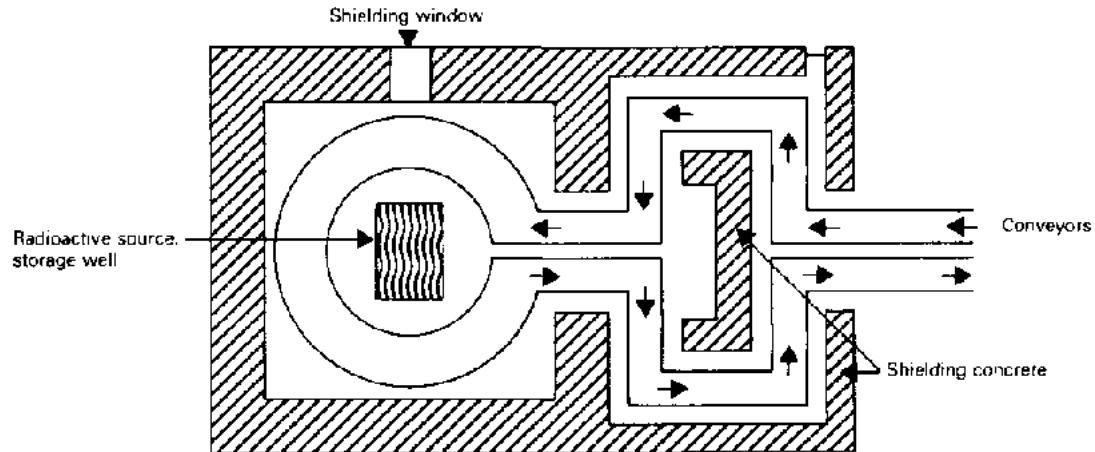
**A source of 5 MeV will induce radioactivity in food at a level of about 0.3 per cent above the natural level; this is considered not to represent a health hazard.**

**When the material which is being irradiated has absorbed 100 ergs energy per gram, it is said to have received a dose of 1 red.**

### **Radioactive sources**

**(a) Spent fuel-rods from atomic reactors have been used for experimental purposes but as their activity falls rapidly (about 97 per cent in 100 days), it is unlikely that they will be used industrially.**

**(b) Cobalt 60, an artificial isotope emitting  $\gamma$ -rays at energy levels of 1.17 and 1.33 MeV, has a half life of 5.3 years, losing activity at the rate of about 1 per cent per month. (A typical layout of a cobalt 60 irradiation plant is illustrated in Figure 12.)**



**Figure 12 - Typical layout of irradiation plant using cobalt 60**

**(c) X-ray machines have the advantages of being switched on/off as required but are expensive in energy demand.**

### **Chemical and biological effects in foodstuffs**

**A direct hit by a wave or particle beam on the cell nucleus may cause total chromosomal disorder, or mutation in micro-organisms or food tissue, but this effect is now considered to be less important in food preservation. Of greater importance is the production of free radicals, the most significant of which is the ionisation of water in the presence of oxygen to give the peroxide ion. The oxidative effect of the peroxide ion no doubt plays a major part in the inhibition of microbial spoilage, demonstrated by the fact that catalase positive micro-organisms are least affected.**

**Unfortunately, the peroxide ion also causes many undesirable changes in the composition**

**of the food e.g. deamination of amino acids, denaturation of protein and both deamination and dephosphorylation of nucleoproteins. While carbohydrates are relatively stable, cellulose may be depolymerised, resulting in a softening of texture. Fats are particularly vulnerable to oxidation as are fat-based pigments susceptible to bleaching. Up to 50 per cent of the vitamin C may be lost while vitamin A and E losses depend on whether they are associated in protein or fat (the latter resulting in higher losses). The ionisation effect also causes concern when considering the possible hazards to the consumer. As many reactions are occurring in the food, it is thought possible that toxic chemicals, e.g. carcinogens, might be produced; therefore, considerable research effort is directed at testing irradiated foods.**

### **Levels of treatment**

**Three levels are considered in processing foods:**

#### **Radappertisation (1 to 5 Mrads):**

**This level of treatment is the most severe and will destroy all spoilage and pathogenic micro-organisms. *C. botulinum* spores require 4.5 Mrad for a 12 D process (this requires that the process reduces a hypothetical *C. botulinum* population by 12 decimal logarithmic cycles). Unfortunately, there are no indicator micro-organisms that will survive such a process. Furthermore, it would stimulate off-flavours and odours and possibly cause textural damage as well. It has been claimed that such changes can be reduced either by blanching, by including antioxidants or by irradiating at - 80 to - 180°C.**

#### **Radurisation (0.5 Mrad)**

**This will eliminate most non-spore forming bacteria and give a significant reduction in the number of spoilage micro-organisms, thus extending the shelf life. Unfortunately, enzymes are not denatured and the ultimate spoilage pattern is changed, requiring a reappraisal of**

**spoilage criteria. However, this process seems to offer the most promise in food preservation to date.**

**Low dose (50 krad)**

**This inhibits sprouting in vegetables and cereals, and kills tapeworms and insects.**

**Legislation and control**

**It has been proposed that the use of irradiation should be prohibited unless specific approval is granted by Governmental authority. Permission should define the food and the type and level of treatment. Plants should be licensed and the regulations should cover plant design and qualifications of the staff. There should be continuous records available relating to the process, e.g. speed, load, period of irradiation etc. International standards should be established covering the measurement of the dose. Biological tests should be continually carried out to check the effectiveness of the process. Labels should declare the treatment and give sufficient detail to assist public health control and to inform the consumer on handling and shelf life.**

**Irradiation of fish and seafood**

**In general, it is thought that, at doses higher than 0.3/0.5 Mrads, discoloration, production of off-flavours etc. would make irradiation unacceptable. Russian workers have claimed favourable results, however, on boiled fish using doses of 1.5/2.0 Mrads with a shelf life of 2 years; also the Americans have obtained favourable results on treating shrimps at a similar level. However, most work has centred on the milder radurisation of seafoods.**

**Such a mild treatment is ineffective against spores of *C. botulinum* and there must, of course, be concern about the ability of type E to produce toxin at 3.3°C. As radurisation**

**only extends shelf life and does not destroy *C. botulinum* spores, refrigeration is necessary, and possible production of botulinum toxin is of considerable concern. Type E has a widespread geographic distribution in temperate waters; little information is available about tropical waters.**

**Some workers have claimed that toxin formation may be more rapid in irradiated fish. However, it is also markedly influenced by the initial number of spores and the actual foodstuff. The inclusion of 5 per cent (w/w) sodium chloride apparently inhibits outgrowth of spores. While the doses under consideration will not reduce numbers of *C. botulinum* spores, the normal spoilage organisms *Pseudomonas* sp., which cause putrefaction and ammoniacal odours, and *Lactobacillus* sp., occurring in shellfish, are significantly reduced in number (thereby extending the shelf life). Therefore, such doses are liable to change the apparent spoilage pattern. Radurisation could, therefore, increase the botulinum hazard. Other pathogenic organisms have been shown to be resistant to mild doses.**

<b>Limiting doses of various pathogens:</b>	
0.1/0.25 Mrad	- <i>Shigella</i> , Enteropathogenic <i>Escherichia coli</i> , <i>Proteus vulgaris</i> .
0.3/0.5 Mrad	- <i>Streptococcus faecalis</i> , <i>S. pyogenes</i> , <i>Staphylococcus aureus</i> , <i>Salmonella typhosa</i> , <i>S. paratyphi B</i> , <i>S. wichita</i> , <i>S. cholerae</i> .

### **Chemical changes**

**From the limited data available, it is clear that generalisations should not be drawn. There are very definite species differences in behaviour and, even when the species is the same, or similar processing conditions pertain, the results are not easily comparable. Moreover, many reports do not make it clear whether the changes they record occurred only during**

**irradiation, or whether they occurred only during storage after irradiation.**

**However, it would seem that, even with the radurisation treatment of 0.3 - 0.5 Mrad, there is some destruction of vitamins and of cysteine, and a range of oxidative changes. Enzyme inactivation is far from complete and many autolytic reactions continue.**

### **Changes caused during treatment**

**Treatment of cod fillets and mackerel by doses of 50 head to 4.5 Mrad caused no changes in the Biological Value (BV) or Net Protein Utilisation (NPU) of the fish protein. This does not indicate that no changes occurred, only that changes did not alter BV or NPU. In fact, the non-essential amino acid cysteine was destroyed at doses in the range of 0.1 - 0.5 Mrad; it was very probably derived from a sulphur-containing amino acid (i.e. cysteine itself, cystine, methionine) or vitamin (thiamine). Thiamine is known to be destroyed by doses in the range 0.6 - 1.0 Mrad.**

**There have been reports that the lipids of the shrimp *Peneus setiferus* are unchanged by irradiation, and that the carotenoid pigments of the shrimp *Crangon vulgaris* are not significantly altered during irradiation. However, it is possible that free radicals produced during irradiation may cause the loss of polyunsaturated compounds during storage after irradiation.**

**Trimethylamine oxide (TMAO) is degraded during irradiation by doses of 0.6 Mrad upwards. The products are variously reported as trimethylamine (TMA), dimethylamine (DMA), tetramethylenediamine, formaldehyde and water. Formaldehyde is known to insolubilise protein and is thought to be partially responsible for toughening of fish flesh during storage. In non-irradiated material, DMA is only encountered in gadoid species during frozen storage; these species possess an enzyme system capable of converting TMAO to DMA. In irradiated samples, DMA seems to be formed also in non-gadoid species.**



## **Changes occurring during storage**

**In Bangladesh, freshwater carp irradiated at a level of 200 - 250 head were found to have an extended storage life (8 - 10 days) compared to untreated fish (1 day). During storage, the volatile acid number (VAN) was found to be a better chemical index of quality than either TMA or TVB (total volatile bases) nitrogen.**

**Similar findings have been reported from the Philippines: VAN increased during storage of dried alakaok (plain croaker) and bisugo (ribbon-finned nemipterid) irradiated at 50 head, alumahon (striped mackerel) and banak (long-finned mullet) irradiated at 100 head, and tribe (shrimp) irradiated at 300 head. VAN increased during storage at 6 and 30°C but TVB and TMA contents did not change after irradiation. This procedure seems most promising, as a quality assessment technique, at present.**

**Shrimp irradiated at 200 head had less than 3 ppm carbonyls immediately after irradiation and this value remained essentially constant during 28 days' storage. Non-irradiated samples contained about 3 ppm carbonyls initially and showed a more rapid increase and spoiled after 21 days. Incipient spoilage corresponded to 5 ppm.**

**Generally, irradiated samples show no increase in TMA or TVB during storage, probably because the bacteria capable of producing these substances have been destroyed.**

## **Quality control**

**With the risk of food poisoning, quality and methods of quality assessment require careful and precise definition. This has not yet proved to be possible.**

**Sensory tests are satisfactory in assessing consumer acceptability. However, they cannot indicate the presence of pathogenic micro-organisms and could be hazardous for panelists.**

**Chemical tests are of limited value for untreated fish. Also, greater variance is found in irradiated fish, as indicated above.**

**Microbiological tests give the only reliable check but take too long to complete. For fresh fish, a total count of about  $1 \times 10(6)/g$  coincides with definite signs of spoilage, but for irradiated fish the level is  $1 \times 10(8)/g$ , thus increasing the chance of toxic effects if consumed. From the above, it should be evident that there is a need for more research into quality checks, particularly indicative tests.**

### **Commercial application**

**While results will vary with species, time of year, etc., it has been demonstrated that at any temperature a 100 per cent increase in maximum shelf life can be expected for samples irradiated at 0.2 Mrad, or about 65 per cent increase for a dose of 0.1 Mrad. Irradiation pre-rigor gives better results (probably because the fish are more fresh). Other results indicate that combined irradiation processes might also offer increases in shelf life, e.g. 0.05 Mrad on board ship and 0.15 Mrad on shore after 3 - 7 days' storage in ice. No loss in nutritional value up to doses of 0.6 Mrad have yet been demonstrated.**

**It is claimed that, if the problem of quality assessment can be overcome, the following advantages would accrue from radurisation:**

- (a) market expansion;**
- (b) better quality than iced fish;**
- (c) reduction of spoilage losses;**
- (d) easier distribution;**
- (e) easier handling.**

**Overall, radurised fish will have to compare well with frozen fish if it is to become acceptable. In adopting radurisation, the following will have to be considered:**

- (a) ambient temperature;**
- (b) hygiene standards;**
- (c) water quality;**
- (d) equipping of vessels;**
- (e) scarcity of other processes;**
- (f) consumer acceptance.**

### **Use of ultraviolet (uv) irradiation**

**UV of wavelength 2000-2950 is generally permitted. However, it has very poor penetrative power and so is limited to treatment of surfaces (e.g., packaging) or relatively transparent liquids. Furthermore, there is no apparent lethal effect on spores; it is only bactericidal. In fisheries its main use is in purifying water used to cleanse oysters.**

### **References**

**For up-to-date information contact: INTERNATIONAL PROJECT IN THE FIELD OF FOOD IRRADIATION, Institut fur Strahlentechnologie, 75 Karlsruhe Postfache 3 640, Federal Republic of Germany.**

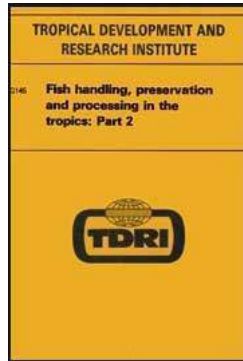
### **Other general sources:**

- 1. AYRES, P. A. (1978) Shellfish purification in installations using ultraviolet light. Lowestoft: Ministry of Agriculture, Fisheries and Food Directorate of Fish Research, Laboratory Leaflet 43.**
- 2. DESROSIER, N. W. and ROSENSTOCK, H. M. (1960) Radiation technology in food. Westport, Connecticut: Avi Publishing Company, 401 pp.**
- 3. KREUZER, R. (Ed.)1969. freezring end irradiation of fish, Published by arrangement**

with the Food and Agriculture Organization of the United Nations, by Fishing News (Books) Ltd, West Byfleet, Surrey, 528 pp.



[Home](#) > [ar](#) [cn](#) [de](#) [en](#) [es](#) [fr](#) [id](#) [it](#) [ph](#) [po](#) [ru](#) [sw](#)



## **Fish Handling, Preservation and Processing in the Tropics: Part 2 (NRI)**

 **(introduction...)**

 **Summaries**

 **Acknowledgements**

 **Introduction**

 **Salting of fish: salt**

 **Salting of fish: methods**

 **Drying of fish: basic principles**

 **Drying of fish: methods**

 **Smoking of fish**

 **Marinades**

 **Fermented fish products: a review**

 **Boiled fish products**

 **Fish canning: theory and practice**

 **Freeze drying**

 **Irradiation**

  **Miscellaneous products: crustaceans**

 **Miscellaneous aquatic products used as food**

-  **Food by-products**
-  **Non-food by-products**
-  **New and delicatessen products**
-  **Fish meal**
-  **Fish silage**
-  **Chemical and physical methods of quality assessment**
-  **Organoleptic (sensory) measurement of spoilage**
-  **Microbiology of spoilage**
-  **Microbiology of fish spoilage**
-  **Public health microbiology**
-  **International standards for fisheries products**
-  **Large-scale fish landing facilities**
-  **Small-scale landing facilities: design and operation**
-  **Retail sale facilities**
-  **Fisheries extension services: their role in rural development**
-  **Training in the field**
-  **Appendix**

### **Miscellaneous products: crustaceans**

**The crustaceans comprise a large group of animals all of which have an external skeleton composed of chitin; in some species, the skeleton is largely calcified. The crustaceans used for food are almost all from the order Decapoda, which means literally ten-legged, and include the prawns or shrimps; crabs; true lobsters; rock lobsters or crawfish and crayfish.**

**The group is more primitive than the true fish since they lack the backbone of vertebrates. However, like the true fish, they obtain oxygen by means of gills and, if these are kept moist, the larger animals can be kept alive for quite long periods out of water; all are easily kept alive in well oxygenated water.**

**Feeding habits vary but many feed on other animals and some, e.g., crabs, have large claws which are used for foraging or capture of prey. Others feed on detritus or dead plant or animal matter. The food is ground up in the gastric mill and then passes through the intestine. In many species, the faecal waste is passed out as pellets. Some species, e.g., the penaeid prawns grow rapidly and reach maturity in less than a year; others, such as rock lobsters (crawfish), grow more slowly and reach maturity at the age of 4 or 5 years.**

**The parts which are eaten include the muscles (flesh), which provide the white meat; the liver, which largely forms the brown meat; and the eggs (roe). The gills are always thrown away in the larger species.**

**All types of crustaceans may be sold whole, sometimes alive, other times freshly killed or cooked. All may be used to make frozen or canned products; some are dried after cooking; others are used to make fermented products. The shells are usually discarded but may be used to make a meal for animal feeding or chitosan. Meal made from whole small shrimp or the heads of larger animals is used for fish feeding, especially salmonids, e.g., rainbow trout, to produce the pink colour in the flesh which is desired by consumers.**

## **Crabs**

**Most species are cannibalistic and scavengers. Most of them are quite easily kept alive out of water (for example mangrove crabs); others can be kept alive only in water, so live boxes must be used. All species spoil rapidly once dead, so they should be kept alive if possible until they are landed. Where this is impossible, they should be chilled but in this case they must be sold and eaten very soon after capture. In Europe, crabs are invariably**

**boiled immediately before sale. They are killed first to prevent the claws and legs dropping off and then boiled in water containing 2 - 3 per cent salt for 20 - 30 minutes depending on size. Boilers should be fitted with a thermometer and a timer. After cooking, the animals should be cooled to set the meat.**

**Cooked crabs are sold either whole, or 'picked', i.e., the meat is removed. The yield is variable and can be up to 30 per cent of the total weight but only a third of this is white meat. Yield depends on the species, the size of the animal and the season. For example, animals which have just spawned yield very little meat.**

**It is possible to use machines for meat removal. These normally operate using the principle of centrifugal force to remove the flesh. The yield is then rather low, however, and the machines are expensive to buy.**

### **Freezing crabs**

**Crabs or their meat should always be cooked prior to freezing. If crabs are frozen raw, the meat becomes very watery and the yield is very low. Crabs can be frozen whole in air blast freezers; alternatively, the meat can be frozen in waxed cartons or consumer packs, or in blocks for caterers and manufacturers. The blocks must be glazed to prevent drying and then wrapped. Freezing must be rapid so that the temperature is reduced from 0 to - 5°C in less than 2 hours and the material must be kept in the freezer until the warmest part is at - 20°C. Storage should be at - 30°C; at this temperature, whole crabs can be kept for 6 months and meat for 4 months. At - 23°C, whole crabs can be kept for 3 months and meat for only 2 months.**

### **Canning crabs**

**It is normally only the white meat that is canned. The meat is washed and dipped in a weak acid to prevent the blue discoloration which otherwise occurs. The dip may be made**

**using 2 oz of glacial (28 per cent) acetic acid to one gallon of water, or 70 parts of 9 per cent salt brine and 30 parts of 1 per cent citric acid. The meat is then packed in parchment paper lined cans or in cans which have a special lacquer lining.**

### **Prawns (shrimps)**

**Prawns have usually been feeding actively when caught and the organs in the head contain large quantities of very active enzymes. Bacterial counts on tropical prawns are often high (10<sup>4</sup> to 10<sup>6</sup>) and dead prawns spoil rapidly unless chilled properly. Even when well chilled immediately after catching, prawns start to lose their delicate flavour after 2 - 4 days. In 5 - 8 days, black spot or melanosis usually occurs in tropical species. This is due to the production of the black pigment melanin by the action of the enzyme tyrosinase on tyrosine. In itself, black spot is harmless but it spoils the appearance of the prawn and indicates that spoilage has started.**

### **Good handling practice in boats used for chilling prawns**

- 1. The trip length should not exceed 5 days after catching starts.**
- 2. The trawling time should be short in order to prevent crushing in the net.**
- 3. The net should be towed at the surface for a short time to wash off any mud and clean the catch; this should not be done for too long because the surface water is relatively warm.**
- 4. On hauling the net on board, the prawns should be sorted from the by-catch at once. They should be protected from the sun and wind and handled carefully.**
- 5. After sorting, they should be washed carefully in clean sea water.**



**6. In all the traditional fisheries in which very high quality material is produced, the prawns are headed at sea, that is, the heads are removed from the bodies and only the tails are stored. This is because (a) heading removes a major source of enzymes; (b) in some places, it is known that the bacterial load on the prawn is heavier in the head; (c) both bulk and weight are reduced so that there is less material to chill.**

**7. The material should be cooled quickly. This requires that plenty of ice in very small pieces should be used, the prawns being stowed in shallow layers. Where boxes are used, it is important that these should not be over-filled so that the prawns are crushed when one box is stood on another. The boxes should be labelled as to species, and each day's catch should be kept separate. The boxes should be stowed in insulated holds. It is important that only clean ice should be used.**

**8. If chilled or refrigerated sea water is used, the water must be at ice temperature.**

#### **Good practice in boats used for freezing prawns**

**1. Follow points 1 - 6 above.**

**2. Quick freezing must be practised. It is better to freeze in blocks rather than to individually quick freeze (IQF) the prawns; this causes less damage, there is less drying and less storage space is needed.**

**3. The prawns should be placed in a cold store at - 30°C.**

#### **Control of black spot in prawns**

**Some control is possible by using solutions of sodium metabisulphite or ascorbic acid. Control is effected either by dipping in a 1.25 per cent solution of sodium metabisulphate for 1 minute before icing or by dipping in 1 per cent ascorbic acid. In either case, it is**

**most important that the dip should be kept at the right strength. When using metabisulphite, it is also important that the dipping time should be kept to 1 minute; shorter times are ineffective and longer times produce the discoloration.**

## **Unloading and handling prawns ashore**

### **Chilled material**

- 1. The material should be unloaded as quickly as possible.**
- 2. The material must not be washed in dock water to remove ice nor must it be left lying around on the ground.**
- 3. The material must be kept chilled.**

### **Preparation for freezing**

**The details of suitable plant construction will be discussed in another lecture because many of the details are similar for prawns, fin fish and other material. Ideally, a plant should process only prawns or other crustaceans. In factories where other material such as fin fish or squid must be processed, there should be a separate line. Where frogs must be processed within the same building, this should be carried out in a separate room because in most places frogs carry a very high bacterial load. Tables and implements used for work on frogs should only be used for other material after very thorough sterilisation.**

- 1. All work surfaces should be of smooth, impervious, non-toxic material which is corrosion-resistant.**
- 2. Unfrozen material must be kept chilled in clean containers using plenty of small pieces of ice. Material which has been frozen at sea should be kept frozen until it is required for**

**thawing.****3. A typical sequence for either chilled or thawed material would be:**

(i)	wash
(ii)	head (if not done at sea)
(iii)	sort into species (if not done at sea)
(iv)	sort into sizes and grades
(v)	check weight to ensure that sizing is accurate
(vi)	peel, or peel and de-vein, as necessary
(vii)	wash all material
(viii)	pack into trays or containers
(ix)	quick freeze
(x)	knock out of trays or remove containers from freezer trays
(xi)	wrap and carton and then master carton.

**4. Absolute cleanliness is essential at all stages. All surfaces should be cleaned frequently. The water used must be clean and fit to drink. It may be chlorinated but the free chlorine level should be kept low so that flavour and colour are not impaired. A level of 10 ppm should be regarded as the maximum.**

**5. Personnel should be properly dressed. They must wash their hands on entering the plant, using soap and hot water and drying their hands only on paper towels which cannot be re-used. Where people are to work on wet processes, there is no need for them to dry their hands but they must wash off the soap. The plant should not have hand-operated taps. Foot taps are ideal. Workers should also wash their hands or gloves at intervals and during processing. They must wash their hands whenever they have been to the toilet.**

## **Drying prawns**

**While very small prawns are sometimes dried without boiling, the larger ones are almost invariably boiled in brine before drying. Local preferences as to saltiness vary but often a brine of about 5 per cent is used. A typical process would be as follows:**

**1. The cooking time should be controlled; about 3 - 5 minutes at 100°C is sufficient for all but the largest prawns. The boiling time should be timed only from when the brine has come up to boiling point. Some processors use stronger brine and cook for longer in order to remove as much water as possible but this produces a slightly inferior over-salted product.**

**2. Cool rapidly by spreading in a thin layer.**

**3. Air-dry on a raised surface. Dried prawns are a relatively valuable material and, in some places, it is profitable to use hot air driers to produce better quality material than would be obtained by slow air drying when the humidity is high. Some degree of fermentation is, however, liked by some consumers.**

## **Rock lobsters (spinylobster, crawfish)**

**In order to achieve a top quality product, these must arrive in the freezing plant while still alive. Although it was shown some years ago that, as with many other crustaceans, the best results were obtained by cooking rock lobsters before freezing, almost all importers insist on buying frozen raw material. This enables the purchaser to use a variety of different cooking methods.**

**A typical freezing operation would be:**

**1. Remove tails from live animals and grade for size.**

**2. Remove the hind gut.**

**3. Wash.**

**4. Freeze - this is usually done in a blast freezer. The material should be quick frozen as for other fish products. The anterior end of the tail is usually wrapped in a small piece of plastic sheet which may be secured with a rubber band.**

**5. Pack the material and then place in cold storage.**

### **True lobsters**

**As with crabs most species are quite easily kept alive out of water, and all spoil rapidly once dead. They should be kept alive until landed and can be chilled in this condition using ice. In Europe, these are again marketed live and are normally carried in wooden or cardboard boxes which may contain insulating materials and ice; lobsters can remain alive for up to 36 hours, depending on the conditions prevailing. When eaten fresh they are boiled whole immediately prior to consumption.**

**Lobsters can be frozen and either the whole animal, which has just died, or the tails are used. They are also canned: the meat is cooked in its own juice or in jelly, mayonnaise or cream sauce.**



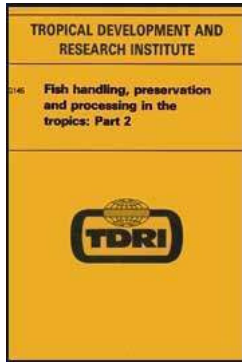
**[Home](#)''' '''> [ar.cn.de.en.es.fr.id.it.ph.po.ru.sw](#)**












**Fish Handling, Preservation and Processing in the Tropics: Part 2  
(NRI)**



***(introduction...)***



- 📄 **Summaries**
- 📄 **Acknowledgements**
- 📄 **Introduction**
- 📄 **Salting of fish: salt**
- 📄 **Salting of fish: methods**
- 📄 **Drying of fish: basic principles**
- 📄 **Drying of fish: methods**
- 📄 **Smoking of fish**
- 📄 **Marinades**
- 📄 **Fermented fish products: a review**
- 📄 **Boiled fish products**
- 📄 **Fish canning: theory and practice**
- 📄 **Freeze drying**
- 📄 **Irradiation**
- 📄 **Miscellaneous products: crustaceans**
- ➔ 📄 **Miscellaneous aquatic products used as food**
- 📄 **Food by-products**
- 📄 **Non-food by-products**
- 📄 **New and delicatessen products**
- 📄 **Fish meal**
- 📄 **Fish silage**
  
- 📄 **Chemical and physical methods of quality assessment**
- 📄 **Organoleptic (sensory) measurement of spoilage**
- 📄 **Microbiology of spoilage**

-  **Microbiology of fish spoilage**
-  **Public health microbiology**
-  **International standards for fisheries products**
-  **Large-scale fish landing facilities**
-  **Small-scale landing facilities: design and operation**
-  **Retail sale facilities**
-  **Fisheries extension services: their role in rural development**
-  **Training in the field**
-  **Appendix**

## **Miscellaneous aquatic products used as food**

**In this session we will consider some aquatic resources that are used as food but are not 'fish' in the strict sense of the word. Many fisheries enterprises and government departments dealing in fisheries take other products such as these under their umbrella, and so it is important that you should know something about them.**

### **Frog legs**

**Frog legs are a popular commodity in many European countries, Japan and North America, and much of the production comes from tropical areas of the world including the sub-continent of India, Mexico, Cuba and the Far East, e.g., Indonesia. The most common products are frozen frog legs. There are a number of different species used, most of which belong to the genus *Rana*.**

**Processing for freezing, as recommended by FAO, is as follows:**

#### **1. Use live frogs only.**

- 2. Place live frogs in a 10 per cent solution of salt (NaCl) containing 250 ppm chlorine for 15 minutes. This treatment partially paralyses and anaesthetises the animal.**
- 3. Cut hind legs at the abdomen, not more than 2.5 cm above the waist so as not to disrupt the gut contents.**
- 4. Wash the legs in chlorinated running water.**
- 5. To reduce Salmonella, hold the legs in chilled (with ice) chlorinated water (500 ppm chlorine) for 2 minutes.**
- 6. Skin the legs and clip the feet as soon as possible.**
- 7. Wash again in iced, running water containing 20 ppm chlorine for 20 minutes to facilitate bleeding.**
- 8. Trim excess pieces of skin, guts etc. and examine for defects such as blood spots, parasites etc.**
- 9. Wash again in chlorinated (500 ppm) chilled water.**
- 10. Finally, wash in 4 - 5 changes of chilled chlorinated (20 ppm) water.**
- 11. Grade into different sizes.**
- 12. During packaging, take care not to contaminate the product. Pack the legs in individual polyethylene bags or film and secure with a rubber band. Treat the wrappers with 20 ppm chlorinated water before use.**
- 13. Freeze the packs into blocks and store at a low temperature (- 40°C).**



**We can see that the above regime involves multiple washing and treatment with chlorinated water. This is necessary because of the high incidence of Salmonella (a pathogenic bacterium) in frogs. Salmonella is present only in the intestine and on the skin of healthy frogs and has no deleterious effect on the living frog; however, once the frog is cut open, contamination of the end product can easily occur unless scrupulous cleanliness and strict separation of raw material and end product are exercised. The end product should comply with the following bacteriological standards according to FAO:**

1 Total viable count at 37°C	Max 5 000 000/9
2 Escherichia coli	Max 1019
3 Coagulase positive staphylococcus	Max 100/g
4 Salmonella or Arizona	Zero/25 g sample

**Many exporting countries run into difficulties with health regulations in the importing countries because of high incidence of Salmonella in frog legs.**

**Frog legs and crustaceans such as shrimp and prawns should not be processed in the same working area.**

### **Molluscs**

**Many different molluscs are used as food throughout the world. They can be processed in a great variety of ways including smoking, drying, canning, freezing, or eaten fresh or even alive. The same basic principles which apply to the processing of other more conventional fishery products are used in the processing of most molluscs.**

**With gastropods such as conch and trochus, the large head/foot is usually eaten fresh or sometimes marinated with vinegar. The muscle is particularly tough and requires tenderisation by beating with a mallet before cooking if eaten fresh. The process of**

**marination also helps to tenderise the flesh.**

**Squid and octopus can be prepared fresh and frozen for use in a variety of dishes and are particularly popular in countries of southern Europe. They can also be dried. Squid is prepared for drying by splitting the ventral side of the body and carefully removing the ink sack and internal shell. The inside is scraped and thoroughly washed before sun drying. Drying can take 10 days and a translucent product is formed.**

**Many bivalves such as mussels and oysters are marinated or brined and bottled or canned. Alternatively, they can be lightly smoked and canned in vegetable oil. In many countries, bivalves such as oysters are dried and smoked to preserve them for local markets. These form a useful supplement to otherwise low-protein diets.**

**Sea cucumbers or beche-de-mer**

**Sea cucumbers (also known as beche-de-mer, sea slugs or trepang) are holothurians which occur, usually, on coral reefs in many tropical areas. They vary in size and colour from species to species. Their market value depends primarily on the species concerned, the most valuable being the teat fish (*Microthele nobilis*), but also depends largely on the size of the specimen (the larger the better), appearance, odour, colour and moisture content.**

**The basic processing consists of removing the viscera from the animals and cleaning the gut cavity; boiling for up to 1 - 1½ hours; a second cleaning to remove the remains of the guts usually by making a longitudinal cut on the top of the animal, then drying either by sun drying, if climatic conditions allow, or by smoking.**

**The main market for beche-de-mer is amongst the Chinese community of the Far East. Most marketing is through agents in Hong Kong and Singapore.**

## **Fish roes**

**True caviar is made from the roe of the female sturgeon but an inferior caviar may be made from the eggs of a number of fish such as salmon and cod. A number of tropical species could yield roes which are suitable as a caviar substitute. The roes are removed from freshly killed fish and rubbed gently through a sieve to remove the membrane. The eggs are mixed with salt (4 - 10 per cent by weight), stirred and left for 10 - 15 minutes; they are then drained, bottled and stored at chill temperatures or pasteurised.**

**Some female roes (e.g., from mullet, shad or Spanish mackerel) are salted and dried in the round. The roes may be dry salted or brined (10 per cent salt by weight) and the salting time varies from 10 to 15 hours. After draining, the roes are sun dried for 5--10 days. The roes may also be smoked to dry them. The shelf life of the dried products depends on the extent of their drying but it can be extended by coating them with a 50:50 mixture of beeswax and paraffin wax. Some female roes can be lightly smoked to give them a characteristic flavour. Soft or male roes from, for instance, herring find a market in Britain when canned.**

## **Turtles**

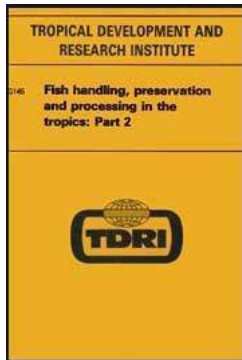
**Turtles and turtle products have formed the basis of a sizeable industry until recently. However, worries of over-exploitation and dwindling stocks of wild turtles have caused a recent decline.**

**The most important turtle used for food is the green turtle (*Chelonia mydas*) which has been used for the production of high value turtle soup in the canned form. For soup manufacture, the calipee and calipash are primarily used. The red meat of all turtles is also eaten. The leathery turtle (*Dermochelys coriacea*) is chiefly exploited for its oil. The Hawksbill turtle (*Eretmochelys imbricata*) is exploited chiefly for its shell as an ornament.**

**The eggs of all turtles are eaten in many parts of the world. Rearing of green turtles particularly has been practised in various parts to try to overcome conservation problems. These projects have had some degree of success. Many countries, however, now have very strict conservation measures in force to help conserve wild stock whilst others are restricting the imports of turtle products.**



[Home](#) > [ar.cn.de.en.es.fr.id.it.ph.po.ru.sw](#)



## **Fish Handling, Preservation and Processing in the Tropics: Part 2 (NRI)**

 ***(introduction...)***

 **Summaries**

 **Acknowledgements**

 **Introduction**

 **Salting of fish: salt**

 **Salting of fish: methods**

 **Drying of fish: basic principles**

 **Drying of fish: methods**

 **Smoking of fish**

 **Marinades**

 **Fermented fish products: a review**

 **Boiled fish products**

 **Fish canning: theory and practice**

 **Freeze drying**

 **Irradiation**

-  **Miscellaneous products: crustaceans**
-  **Miscellaneous aquatic products used as food**
-  **Food by-products**
-  **Non-food by-products**
-  **New and delicatessen products**
-  **Fish meal**
-  **Fish silage**
-  **Chemical and physical methods of quality assessment**
-  **Organoleptic (sensory) measurement of spoilage**
-  **Microbiology of spoilage**
-  **Microbiology of fish spoilage**
-  **Public health microbiology**
-  **International standards for fisheries products**
-  **Large-scale fish landing facilities**
-  **Small-scale landing facilities: design and operation**
-  **Retail sale facilities**
  
-  **Fisheries extension services: their role in rural development**
-  **Training in the field**
-  **Appendix**

## **Food by-products**

**In this session, we will consider the many different products from the fishing industry which do not make up a main livelihood for a processor or processing plant but could be said to be by-products from the main industry. Many of the examples used are from the**

**Japanese fishing industry. Japan is a great fish-eating nation and almost all the products from the fishing industry in Japan are used in one form or another.**

### **Shark fins**

**Dried shark fins are used in Chinese cookery and produced in considerable quantities in many parts of the world. The main exports are to China, Hong Kong and other Chinese-orientated societies. The process used for shark fins is similar throughout the different countries. The fins, mostly the spinal and caudal, are cut from the animal and any adhering flesh is removed as far as possible. The fins may be dusted with salt in a ratio of approximately 1 part of salt to 10 parts of fish, the cut portions being liberally sprinkled with salt and then set aside for about 24 hours. The fins are then washed in water and either hung up or spread out to dry in the sun for a very long period (up to one month). The moisture content after drying is generally about 7 to 8 per cent. The dried fins are then packed in sacks under pressure so that they are flattened during storage.**

**Shark fins are prepared not only as plain dried fins but also as dried fin rays. By boiling shark fins to remove the outer skin, naked fin rays can be obtained. Shark fins are removed from the fish bodies and soaked in fresh water to soften for 4 to 5 days. After softening, the fins are heated in water at 90°C for 20--30 minutes so as to swell them and remove the epidermis. Once the epidermis has been removed, the rays can be separated from one another by softening the gelatine between them in hot water. The rays are called shisai in Japan and can be either white or black; the fin rays which have been dried in the sun are called taishi.**

**Also in Japan the cartilage from rays and sharks is prepared for export to China in the same way as shark fins. The cartilage of the jaw, fin and head is cut into pieces 7 - 9 cm long and soaked in hot water to remove the adhering meat. The prepared cartilage is then boiled in water and dried in the sun. The product should be an amber colour after drying.**

**The product is known as meikotsu in Japan.**

**The dried fins and cartilage are generally used in Chinese cookery as thickening agents in soups.**

### **Fish entrails**

**In Japan, cod stomachs together with the gills and gullets are salted for preservation and consumption. In many countries, the entrails of fin fish, sea cucumbers and urchins etc. are fermented in much the same way as products from whole fish and fish flesh to make sauces and pastes for condiments. In many parts of the world, fish entrails are included in a process or a preserved product and are consumed with the rest of the fish. In other areas where guts are removed, they may be sold separately at the retail market usually at a very low price; they may even be given away to beggars. In other circumstances, of course, the guts etc. may be converted into fish meal, silage etc. for animal feeding.**

### **Fish extract**

**In many fish preparation procedures, the fish may be salted in brine or boiled in brine or plain water as part of the procedure. Sometimes this water is used as a food because it contains fishy flavours and some nutrients. Most often it is used as a condiment to other dishes.**

**In Hong Kong, boiled dried oysters are produced. After boiling and removal of the oysters, the water in which they have been boiled is concentrated to form a brown liquid. Starch is added to this liquid to thicken it and sodium benzoate to preserve it. It is then bottled or canned and used as a condiment.**

**On the Minicoy Islands of India, a tuna fish paste is prepared from diluted sea water in which tuna fillets have been boiled. After this water has been used up to eight times for**

**tuna boiling the liquid is concentrated to a thick paste.**

**The petis produced in Indonesia is made from the concentration of water used in boiled fish preparation. Sugar is added to the water after the fish have been boiled in it and the mixture slowly concentrated to a brown viscous fluid. The petis can also be produced from the water used in the production of shrimp products such as matsuurazuke in a similar fashion.**

**In Vietnam, a shrimp extract is prepared from the heads and shells of dried shrimp. The shrimp waste is boiled in water for several hours, sugar is added and the liquid concentrated to a thick syrup.**

### **Miscellaneous products**

**In Japan, the soft bone of whale may be sliced and pickled in salt and rice wine lees to produce a product known as matsuurazuke. Also in Japan the eggs of sea cucumber may be salted and dried for consumption as hoski konoka.**

**There are many other such products throughout the world using bits and pieces which would otherwise go to waste.**

### **Pet foods**

**Much fish which would otherwise be wasted is not used in fact for human consumption but can be used as pet food. In Japan, the dark meat of tuna, which can constitute up to one sixth of the total from the fish, is canned and used for pet food. In many countries similar sorts of operations are undertaken either with canning the entrails or possibly freezing them into packs for retail sale.**

### **References**

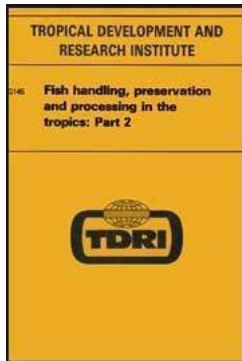


**SUBBA RAO, G. N. (1967) Fish processing in the Indo-Pacific area. Food and Agriculture Organization of the United Nations, Rome (FAO) Indo-Pacific Fisheries Council Regional Studies, No. 4.**

**TANIKAWA, E. (1971) Marine Products in Japan. Tokyo: The Koseisha-Koseikaku Company, 507 pp.**



[Home](#) > [ar.cn.de.en.es.fr.id.it.ph.po.ru.sw](#)



 **Fish Handling, Preservation and Processing in the Tropics: Part 2 (NRI)**

 **(introduction...)**

 **Summaries**

 **Acknowledgements**

 **Introduction**

 **Salting of fish: salt**

 **Salting of fish: methods**

 **Drying of fish: basic principles**

 **Drying of fish: methods**

 **Smoking of fish**

 **Marinades**

 **Fermented fish products: a review**

 **Boiled fish products**

 **Fish canning: theory and practice**

-  **Freeze drying**
-  **Irradiation**
-  **Miscellaneous products: crustaceans**
-  **Miscellaneous aquatic products used as food**
-  **Food by-products**
-  **Non-food by-products**
-  **New and delicatessen products**
-  **Fish meal**
-  **Fish silage**
-  **Chemical and physical methods of quality assessment**
-  **Organoleptic (sensory) measurement of spoilage**
-  **Microbiology of spoilage**
-  **Microbiology of fish spoilage**
-  **Public health microbiology**
-  **International standards for fisheries products**
-  **Large-scale fish landing facilities**
-  **Small-scale landing facilities: design and operation**
-  **Retail sale facilities**
-  **Fisheries extension services: their role in rural development**
-  **Training in the field**
-  **Appendix**

## **Non-food by-products**

### **Fish body oils**

**Fish body oils are usually produced during the wet reduction process used for meal manufacture, the liquor from the press being passed either to a series of settling tanks or to a series of centrifuges. The press liquor is an oil/water emulsion containing dissolved proteins and other substances as well as particulate matter; the quantity of organic matter other than oil depends on the condition of the fish when processed, the degree to which the fish is cooked and the manner in which the press is operated. Pressing stale, soft fish, or over-cooking fish, can result in a press liquor containing large quantities of valuable organic matter and, even in a well conducted plant, the quantities may be considerable.**

**Both the settling tanks and centrifuges are heated to help to break the emulsion and prevent the solidification of the stearin portion of the oils. Five or more heated tanks may be used in series; the press liquor is admitted to the first tank at a point well below the surface, the oil rises to the top and is passed to the bottom of the second tank of water, the process being repeated in succeeding tanks. The oil is finally heated to dry off remaining water. In a centrifuge system the water phase is spun off and the almost clean oil is heated to about 200°F (94°C), mixed with clean water at the same temperature, then passed to the polishing centrifuge which yields a clean bright oil. In modern plants, centrifuging is more usual since the oil produced is finer, cleaner and brighter and has a lower moisture content than the oil from a settling tank system. The oils produced by settling, being poorer in quality, fetch lower prices than centrifuged oils and are less suitable for some commercial purposes.**

**It is unusual to attempt to produce oil by pressing the meal scrap from a dry reduction process. Oil extracted in this way would, in most cases, be darkened by contact with the metal surfaces of the drier and a hydraulic press would be required for the extraction.**

**Fish body oils (and liver oils) consist principally of the esters of fatty acids and glycerol (glycerides) together with unsaponifiable matter; they represent the fishes' energy store. As noted previously, the oil content of a fish species may vary appreciably at different**

**seasons and this variation may be related to either a feeding or spawning cycle. Watts, working with the West African shad, known locally as the bonga (*Ethmalosa dorsalis*), found that the fat content varied during the year from two to seven per cent of the wet weight. The variation in fat content appeared to be related to the abundance of diatoms in the diet; larger fish also had higher fat contents than smaller ones.**

**The percentage of oil plus water present in any fish species remains almost constant at different seasons, the water content falling as oil is stored and vice versa; this means that the form of the fish body changes much less than that of land animals which store fat as a food reserve. This is of obvious importance in animals which are streamlined for ease of passage through a relatively dense fluid.**

**While the oils from different species show considerable variation in their fatty acid composition, a common feature is the high percentage of unsaturated fatty acids present. It is this feature which renders fish oils more reactive than those of most land animals and vegetables. It is generally believed that the characteristic odour of fish oils is at least partly due to the presence of highly unsaturated fats, for when such oils are hydrogenated the odour is lost.**

**The main features which affect the quantity and quality of fish oils obtained during processing are the fish species, the food consumed, the spawning cycle and the water temperature. Fish are generally able to modify oils taken into the body; if large quantities of a particular oil are ingested this mechanism may fail. Carp fed on maize may thus develop a peculiar flavour due to the presence of quantities of maize oil. With the onset of the spawning season, many fish cease to feed and stored oil is used to build up the gonads as well as for the supply of energy. Fish caught in cold water are reported to show a higher degree of unsaturation in the oil than those of the same species caught in warmer waters.**

**Deterioration in fish oils results from the development of free fatty acids and the development of oxidative rancidity. The former is brought about by lipases present in the oil and in contaminating micro-organisms, the latter by atmospheric oxidation or by lipoxidases present in the fish or contaminating micro-organisms. Flavour reversion in deodorised oil may also take place. Deterioration may be controlled by heating to 176 - 212°F (80 - 100°C) for 15 - 20 minutes which inactivates the enzymes, by the addition of anti-oxidants, by halogenation or by storage under an inert gas, usually nitrogen. Brody reviews the literature and gives an account of deterioration and its control.**

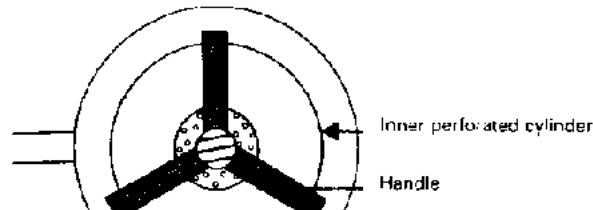
**Many fish oils are converted into solid compounds when atmospheric oxygen is absorbed, and such drying oils are suitable for use in paints and varnishes. A few oils are classified as semi-drying and these are not suitable for such purposes. Any fish body oil can be converted into a form suitable for human consumption; examples include canning oils, margarine and cooking fat. These oils are also used in animal feeding especially as carriers for the oil soluble vitamins A and D. Other processes in which fish oils are used include the manufacture of linoleum, detergents, rubber, lubricants, printing inks, leather and cosmetics.**

### **Fish liver oils**

**Fish liver oils were formerly the most important source of vitamins A and D. Vitamin A can now be manufactured synthetically by cheap processes and there has thus been some decline in interest in the production of liver oils in western countries. Vitamin oil production would of course be of interest in the developing countries where any manufacturing process using local materials could reduce the use of foreign exchange but, unfortunately, the two most important fish species used in the past for vitamin oil production (cod and halibut) are cold water fish. Some tropical fish species, however, possess livers rich in vitamins and these represent a little exploited resource of considerable nutritional significance.**

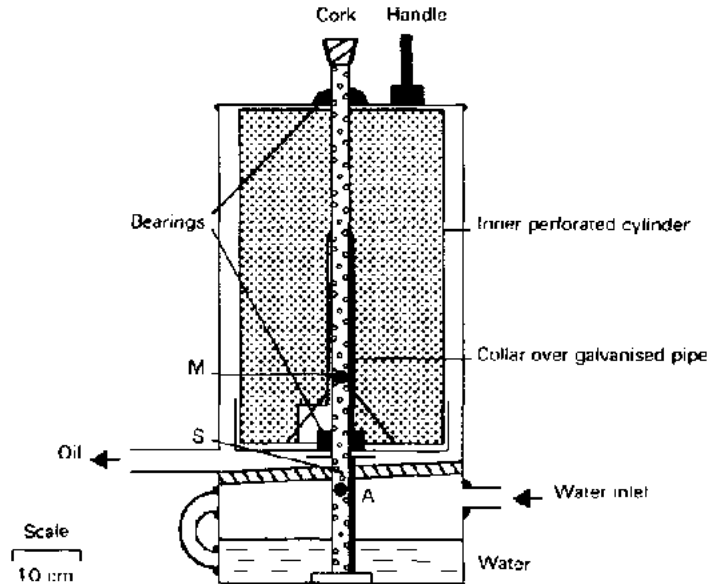
The two most obvious possible sources of vitamin oil would be the various tunas and allied species and some of the sharks. Tuna livers are small in relation to the fish body but the liver oils themselves contain relatively large quantities of vitamins A and D. The sharks vary greatly in their liver oil vitamin content: certain species such as the soupfin and hammerhead have high vitamin contents in the liver oils; other species such as the tiger, dusky and leopard sharks have liver oils poor in vitamins. It would, in most situations, be difficult to obtain tuna livers as the fish are gutted and then frozen at sea; in other cases, the fish are landed in small numbers at isolated points on the coast. The second difficulty also applies to the use of shark livers. The utilisation of shark livers presents a further problem in that it would be necessary to sort the livers of the various species in order to avoid the processing of livers having oils of low vitamin content.

Various procedures for the extraction of oil from livers are used depending on the percentage of oil present in the liver and on the vitamin potency of the oil. Livers with high oil content and low vitamin A potency are usually extracted by steaming; the released oil floats and can then be collected by bailing or permitting it to overflow; the cooked mass may be centrifuged. Temperatures of 185 - 190°F (85 - 88°C) are used in Norway when direct steaming is practised; indirect heating may also be employed, the livers being heated to 158 - 167° F (70 - 75°C) and stirred to make them disintegrate more readily. Bailey (See Figure 13) describes a simple small-scale apparatus for the extraction of oil from cod livers; a similar apparatus would appear to be suitable for the extraction of oil from shark livers.





Plan view

**Instructions**

1. Fill with 3 quarts of water.
2. Place over stove or fire.
3. Place tivers in inner perforated cylinder.
4. When boiling raise collar and insert cork. Steam then flows through hole A into S and out of M into fuove

5. Boil for 5 hours, adding livers when necessary and spin occasionally to remove oil.

**Source:** Adapted from a drawing on page 50 of 'Fishery By Products Technology', by J. Brody. AVI Publishing Company, PO Box 831, Westport, Connecticut, 06881 USA (1965).

### **Figure 13 - Small-scale extractor of cod-liver oil**

**Excessive heating and oxidation must be avoided or the potency of the vitamins may be destroyed. As vitamin A is inactivated by light, the oils must be stored in the dark.**

**Livers of low oil content cannot be steam-treated satisfactorily since the oil yield would then be too low; suitable methods include alkali and alkali/enzyme digestion processes and solvent extraction. In a typical alkali digestion process, 1 - 2 per cent by weight of sodium hydroxide or 2 - 5 per cent sodium carbonate is added to ground livers and the mass stirred while being heated to 180 - 190°F (77 - 88°C). The liquified mass is centrifuged to extract the oil.**

**Fish livers spoil very rapidly and oil extraction must take place before spoilage sets in, unless the livers are suitably preserved. Freezing offers the best method of preserving livers as freezing ruptures some of the cells thus releasing the oil. Salting is a cheaper alternative: the livers should be washed and cleansed of blood and slime and then cut into slices 2 - 3 inches in thickness and butt salted using 10 per cent by weight of salt. Salted livers must be stored in airtight containers to prevent oxidation.**

### **Uses of fish skins and scales**

#### **Fish glue**

**A slow setting liquid glue can be made from fish skins and fish heads, which is suitable for furniture making, small repair work, and in book binding, labelling and similar uses. It would almost certainly be impractical to consider the use of fish heads in the developing**



**countries and the use of skins could only be practised in the few countries where skinned fillets are frozen. In the United States, only thick skins from cod and similar species have been used in the past, the skins coming mainly from the cod salting and drying industries. Most tropical fish species have large scales and relatively thin skins and these would be unsuitable for glue manufacture. Fresh skins may be used or the skins may be salted and dried to provide buffer storage.**

**The skins are washed in cold fresh water, all salt and rubbish being removed. Fresh skins require up to two hours washing, salted skins may need as much as 18 hours. The washed skins are cooked for about eight hours in steam jacketed cookers fitted with perforated plates near the base, a weight of water equal to the skin weight being added. A second run may be made in a similar manner yielding a weaker glue.**

**The liquid glue can be concentrated in open-heated pans at atmospheric pressure but it is now more usual to use a vacuum evaporator. Concentration should proceed until the liquid contains from 50 - 55 per cent solids. Small amounts of inexpensive volatile essential oils are added to preserve the glue and mask the fishy odour.**

### **Leather manufacture**

**An alternative use for fish skins would be to make leather from them. Only shark skins can be used to make an attractive hard wearing leather but suffer from the disadvantage that the shagreen (the shark tooth-like 'scales') must be removed; this cannot be achieved by scraping without damaging the skin and chemical methods must be used. There is no reason why fresh skins should not be processed, given an adequate and regular supply, but it is normal practice to clean, salt and dry the skins. Reader gives details of the skinning and preservation procedures. Skinning sharks is not difficult provided that plenty of space is available and proper preservation is quite simple. Correct skinning does, however, waste quite large quantities of meat. Unless the skin is removed with adhering**

**meat, it is easily cut and thus spoiled; however, a somewhat mutilated carcass results if the main objective is to obtain the skin, and the meat is then less suitable for drying or sale as human food in some other way. The collection of skins for leather production is thus probably only possible where large sharks are not eaten. The carcasses could, of course, be reduced to meal but the reduction of shark carcasses also offers some problems as the large quantities of cartilage present may cause balling in a drier.**

**Dried salted skins are freshened in cold water and placed in lime liquor to open the fibre bundles. The liming process may be repeated several times and lime is afterwards removed with ammonium chloride or sulphate and the elastin removed with pancreatic enzymes (bating). Either vegetable or chrome tannage follows, both being preservative processes. Where vegetable tannages are used, an acid milling process follows in which the shagreen is removed. When a chrome tannage is employed, the removal of the shagreen takes place before tanning. Various drying and fat liquoring processes follow, the purposes of the latter being to make the skins more pliable and water resistant; the skins are finally dried and finished.**

**The skins of some of the smaller cetaceans (dolphins or porpoises) can be used to make very strong and durable leather. In many tropical species, the skin is too thin for this purpose.**

### **Artificial pearl manufacture**

**Artificial pearls are made by coating glass or alabaster beads with guanine crystals in a lacquer base, or by coating the inside of hollow glass beads with the same material and then filling these with wax. The guanine crystals from which the lacquer is made are obtained from a variety of species of silvery fish, principally the clupeoids, such as herrings and sardines. It is these crystals, which are brilliantly lustrous, which provide such fish with their sky camouflage. Most of the guanine is in the skin but some adheres to**

**the scales which are the source of the guanine used in pearl lacquer manufacture. Pearl essence is used in the manufacture of a number of articles other than artificial pearls, such as plastic trays, door furniture, fishing rods and textile finishes.**

**The types of fish which yield suitable scales are among the commonest of all fish species and it is unlikely that a developing country would find an export market for pearl essence. Lacquers could, however, be produced for local use.**

**Scales are collected from the holds of fishing boats, usually by providing these with a false bottom. The scales may be preserved by storing in weak brine but they must not be dried. The guanine crystals are removed by mechanical scrubbing and centrifuging; they are then cleaned and suspended in water or an organic solvent or acid, acetone and amyl acetate being commonly used.**

#### **Pharmaceutical and biochemical products**

**Several of the substances commonly used in medicine which are obtained from mammals could be obtained instead from fish in developing countries where meat animals are not available. The most important of these are bile salts and insulin; since the insulin-containing islets of Langerhans are found attached to the gall bladder which contains the bile salts, the manufacture of the two products could be undertaken conveniently in the same small plant. This, of course, pre-supposes that fish are being marketed in such a way that they pass through a plant where the entrails are removed or that a sufficient number of large fish are gutted at sea to yield a worthwhile number of large gall bladders. Such situations are at present somewhat rare. The raw material must be taken from freshly dead fish and suitably preserved. The best way to preserve the insulin-containing caps would be to freeze in dry ice and hold the material thus frozen until it could be processed; an alternative is to hold the material in 95 per cent alcohol acidified with 0.3 per cent hydrochloric acid but even then the material must be chilled with crushed ice, kept in the**

**dark and processed in less than 24 hours. Brody gives details of the preparation of insulin, and he also gives a method for the collection of bile.**

**Proteolytic enzymes suitable for use in leather bating, meat tenderising or in preparing fermented, liquified products from meal or fish could be obtained from the pyloric caecae of the larger tropical species of carnivorous fish. However, the collection of such material would be subject to the difficulties already discussed.**

### **Fish albumin**

**In those few developing countries where substantial quantities of egg albumin are used in the food industry, fish albumin, which would have similar physical and chemical properties, could be manufactured from fish scrap, fillet waste or unwanted small fish. Unrefined or technical grades for use in the manufacture of foam rubber, paper, cosmetics, textiles and a number of similar industrial products could also be made.**

**According to Brody, a technical grade could be manufactured by mincing the raw material, heating it to 160 - 176°F (70 - 85°C) for an hour in an aqueous solution with 0.5 per cent acetic acid in order to produce partial hydrolysis. The partially hydrolysed material should be washed in cold water, then pressed to leave less than 40 per cent of water in the cake. Any oil present is then removed from the cake using ethyl alcohol or trichloroethylene chloride, following which it is dried under vacuum at about 120°F (50°C). The food grade is produced by caustic digestion of the technical grade.**

### **Swim bladders**

**These are also known as air bladders, sounds and fish maws. The Chinese use the dried bladders as a base for soups; the principal international market is for isinglass, which is used to clarify wines and beers. In the UK, the better grades are used for beer fining; continental markets accept lower grades for wine fining.**

**Possible sources are the polynemids (thread fins), sciaenids (jewfish), Lates spp., catfish and carps. Generally speaking, fish of 25 - 100 lb (10 - 40 kg) are used.**

**Preparation: The bladders should be removed and all blood and adhering fat scraped off; they are washed and air dried. They may be dried whole or split. They should be stored in dry conditions.**

**Shipment: Shipments of several hundredweights are packed in wooden boxes, crates etc. Samples of 2 - 3 lb (1 - 1½ kg) will establish a value.**

**Prices: Top quality £1.50 per pound (£3.30 per kg); low grades £0.20 per pound (£0.44 per kg).**

### **Fertilisers**

**There are still a few minor tropical fisheries in which small fish or otherwise unutilisable species are reserved for manure; usually the unsalted carcasses are sun dried for ease of transport. Fillet waste from freezing or drying operations could also be used; the fillet waste from Maldive fish processing is dried beside the smokehouse fire for use in this way. The heads and shells of sun dried shrimps can be ground to make a useful fertiliser as can the carapaces of crawfish. Crawfish waste should never be discarded on the fishing grounds as the breakdown products are through" to drive other crawfish off the grounds.**

**Drying operations of this kind are certain to attract insects and should therefore be carried out at a distance from any processing for human consumption.**

### **Turtle products**

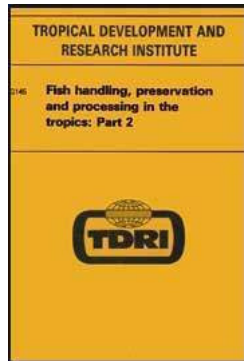
**There is a small market for green turtle as soup. In view of the conservation issue, it is very doubtful whether the turtle should at present be exploited at all in most areas.**

**Exploitation for this luxury (high value) trade may be a better alternative than local consumption of eggs.**

**Tortoise shell from the hawksbill finds a small market; local crafts for the tourist trade possibly offer the best outlet. Items produced must be attractive and of first rate workmanship.**

















[Home](#)''' ''''''> [ar.cn.de.en.es.fr.id.it.ph.po.ru.sw](#)



## **Fish Handling, Preservation and Processing in the Tropics: Part 2 (NRI)**

 **(introduction...)**

-   **Summaries**
-  **Acknowledgements**
-  **Introduction**
-  **Salting of fish: salt**
-  **Salting of fish: methods**
-  **Drying of fish: basic principles**
-  **Drying of fish: methods**
-  **Smoking of fish**
-  **Marinades**
-  **Fermented fish products: a review**
-  **Boiled fish products**
-  **Fish canning: theory and practice**
-  **Freeze drying**

-  **Irradiation**
-  **Miscellaneous products: crustaceans**
-  **Miscellaneous aquatic products used as food**
-  **Food by-products**
-  **Non-food by-products**
-  **New and delicatessen products**
-  **Fish meal**
-  **Fish silage**
-  **Chemical and physical methods of quality assessment**
-  **Organoleptic (sensory) measurement of spoilage**
-  **Microbiology of spoilage**
-  **Microbiology of fish spoilage**
-  **Public health microbiology**
-  **International standards for fisheries products**
-  **Large-scale fish landing facilities**
-  **Small-scale landing facilities: design and operation**
-  **Retail sale facilities**
-  **Fisheries extension services: their role in rural development**
-  **Training in the field**
-  **Appendix**

## **Summaries**

### **Summary**

#### **Fish handling, preservation and processing in the tropics: Part 2**

**This report is the second of two TPI Reports, G144 and G145, which together present 52 lectures for an eight-week training course suited to people working at middle-management level in both Government and Industry. The lectures should be used in conjunction with audio-visual aids, demonstrations and practical sessions.**

**In this report, traditional processes, such as salting, drying and smoking, as well as fermented, marinated and boiled products, are discussed in detail. More advanced processes, such as canning, freeze-drying and irradiation, and various fisheries products and by-products are also described. Other subjects include quality assessment, the microbiology of spoilage, public health microbiology, landing and retail facilities, extension services and training.**

## **Rsum**

**Manutention, conservation et transformation du poisson dans les pays tropicaux: 2eme partie.**

**Ce rapport est le deuxime de deux rapports du TPI, G144 et G145, qui ensemble prsentent 52 confrences pour un cours de formation de huit semaines destin des personnel travaillant un niveau de cadres moyens dans le gouvernement et l'industrie. Les confrences doivent tre utilises en liaison avec des moyens audio-visuels, des dmonstrations et des sances d'application pratique.**

**Dans ce rapport, on prsente en dtail les procds traditionnels, tels que salaison, schage et fumage de mme que les produits ferments, marins et cuits. On dcrit galement des procds plus avancis, tels que mise en conserve, Iyophilisation et irradiation ainsi que diffrents produits et sous-produits de la pche. D'autres sujets comprennent l'valuation de la qualit, la microbiologic de la dtrioration, la microbiologic sur le plan de la sant publique, les installations de dbarquement et de vente en dtail, les services d'extension et de formation.**



## Resumen

### Manejo, conservacin y elaboracin de pescado en las regiones tropicales: Parte 2.

Este es el segundo de dos informes del TPI - G144 y G145 - los cuales en conjunto ofrecen 52 conferencias para un curso de preparacin de ocho semanas de duracin apropiado para personas a nivel administrativo medio, tanto en el gobierno como en la industria. Las conferencias deben usarse en conjuncin con ayudas audiovisuales, demostraciones y sesiones de tipo prctico.

En este informe se analizan detenidamente aquellos procesos tradicionales tales como la salazn, el secado y ahumado, adems del fermentado, salmuera y hervido de productos. Tambin se describen procesos ms avanzados tales como el enlatado, el secado por congelacin y la irradiacin, as como varios productos y subproductos de pesqueras. Entre los dems temas cabe mencionar la valoracin de calidad, la microbiologa del deterioro, la microbiologa de sanidad pblica, los servicios de desembarque y de venta al por menor, los servicios de extensin y de adiestramiento.



[Home](#) > [ar.cn.de.en.es.fr.id.it.ph.po.ru.sw](#)

### Fish Handling, Preservation and Processing in the Tropics: Part 2 (NRI)

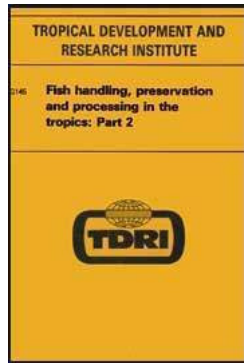
 [\(introduction...\)](#)

 [Summaries](#)



 [Acknowledgements](#)

 [Introduction](#)

 [Salting of fish: salt](#)



-  **Salting of fish: methods**
-  **Drying of fish: basic principles**
-  **Drying of fish: methods**
-  **Smoking of fish**
-  **Marinades**
-  **Fermented fish products: a review**
-  **Boiled fish products**
-  **Fish canning: theory and practice**
-  **Freeze drying**
-  **Irradiation**
-  **Miscellaneous products: crustaceans**
-  **Miscellaneous aquatic products used as food**
-  **Food by-products**
-  **Non-food by-products**
-   **New and delicatessen products**
-  **Fish meal**
-  **Fish silage**
-  **Chemical and physical methods of quality assessment**
-  **Organoleptic (sensory) measurement of spoilage**
-  **Microbiology of spoilage**
-  **Microbiology of fish spoilage**
-  **Public health microbiology**
-  **International standards for fisheries products**
-  **Large-scale fish landing facilities**
-  **Small-scale landing facilities: design and operation**

-  **Retail sale facilities**
-  **Fisheries extension services: their role in rural development**
-  **Training in the field**
-  **Appendix**

## **New and delicatessen products**

### **New products**

**With the rapidly expanding world population and limited size of the world's food resources, it is becoming increasingly important that all fish resources should be fully used. It is estimated that, for instance, 5 000 000 tonnes of shrimp by-catch are wasted each year when they are thrown back into the sea. Similar quantities of presently unmarketable and unpopular fish are wasted in other areas. Considerable quantities also of fish offals and waste are either completely wasted or turned into animal feeds or fertilisers. These products have a less significant effect on human nutrition than they would if used directly for human consumption. The search for new products able to make use of these otherwise wasted fish is a continuing one. The products must be acceptable to a consumer willing to pay the price of the processing involved in their production. Presently, the most active field of research and development is the use of fish minces.**

### **Fish minces**

**The flesh from species of fish which are unmarketable as whole fish or in conventional fish products can be used as a mince. The removal of flesh and subsequent mincing disguises the original nature of the fish and the consumer may well accept a product made from the fish mince when he would not have accepted the original whole fish.**

### **Production of the mince**

**It is feasible for the flesh to be removed from the fish using hand tools such as filleting knives and then passed through a conventional meat mincer (either hand-operated or powered by an electric motor). On a small scale, and where relatively large fish are concerned, this may well be the most economical way of producing the mince. However, many of the fish that might be used for production of minces are small and occur in relatively large quantities (e.g., shrimp by-catch). Under these circumstances, it may be more advisable to contemplate the use of a mechanical device for removing the flesh from the fish. There are a number of machines capable of achieving this, generally known as 'meat/bone separators'. These are able to separate the soft parts of the fish (flesh, guts, nervous system etc.) from the harder parts (bones, scales, skin etc.). The yield of flesh from a meat/bone separator is greater than that from manual filleting and filleting machines since it will recover the flesh from the head, belly flaps etc., which may not be included in a normal fillet. Indeed, the carcasses of fish after fillets have been removed will yield a significant proportion of minced flesh if passed through a meat/bone separator.**

**It is feasible for whole ungutted fish to be passed through a separator but the guts will also pass through the machine with the flesh, producing a non-white mince containing gut contents, blood etc. In certain cases, this sort of mince may be acceptable but often the fish need to be gutted and washed before separation.**

### **Uses of the mince**

**Having produced a mince by one means or another what sort of products can be made? In many fish freezing operations where products such as fish fingers, sticks, cakes, balls etc. are being produced, fish mince stripped from the frames after filleting using a separator is incorporated into the final product. This maximises yields, and the production of these types of fish products is almost entirely confined to the developed countries of the world as convenience-type foods. Apart from these conventional products, other uses of minced fish, particularly from underutilised species, may be as additives to the preparation of**

**processed meat products.**

**In the context of developing countries, however, a major area of interest is the use of minced fish for the production of low-cost salted and dried products. This process may be particularly suitable for the utilisation of shrimp by-catch and other waste fish. Salted fish is an integral part of the diet in many developing countries. With traditional techniques, the salting operation takes several days to complete and during the early stages there may be insufficient salt to prevent spoilage. The need for a more efficient technique to rapidly salt fish was recognised by Del Valle and co-workers who developed a method in which minced fish was mixed with sufficient salt to denature the proteins; the water thus released was pressed out and the pressed cake was sun dried. The technique was designed for use in developing countries and, as such, required little processing equipment. The process was subsequently adopted by several other workers using a similar technique and more sophisticated equipment, producing a blander product more akin to the taste of the western countries. This was the subject of acceptability trials by the World Food Programme in the tropics. This type of product has considerable potential in the tropics if it can be made from more oily fish, the current products being made from species of low fat content. In our own laboratories and overseas programmes, we are attempting to develop a salted/dried fish product using processing methods which could be applied at the village level in the tropics.**

**The work is concentrated on two main areas and two types of product. Firstly, the production of salted minced fish cakes similar to those produced by Del Valle but which do not require excessive pressure during production and, secondly, the production of salted fish powders. It is important that salt is evenly distributed through fish minces if they are to be adequately preserved. When a mincer is being used to comminute fish flesh this can be achieved simply by mincing the fish and salt together. This method has been used successfully in the field to produce salted/ dried fish cakes from waste fish resulting from commercial filleting operations. If other methods of comminution are used, mixing of salt**

**into the mince can be achieved by hand but there are obvious advantages in the use of mechanical mincers. Addition of salt to minced fish muscle releases some of the bound water. In order to reduce subsequent drying times, as much of this water as possible should be expelled before subjecting the material to drying either mechanically or in the sun. This can be done by decanting, pressing or draining through cheesecloth. Once produced, the salted and drained fish mince can be dried either in thin layers in trays or in the form of cakes moulded using a hand-operated hamburger press. The drying operation can be undertaken using a mechanical drier, a solar drier or by simple sun drying. At the village level, simple sun drying would probably be the most economical method provided that the climatic conditions are suitable. Many tropical countries suffer periods of high rainfall and, during these periods, sun drying would not be possible. A non-mechanical kiln of the Ivory Coast type has been used during these periods in the tropics to produce a smoked/dried product. It has been shown that the optimum concentration of salt for the production of fish cake from raw fish is approximately 15 per cent. At salt concentrations below 15 per cent, the water-holding capacity of the proteins in the flesh is high and it is difficult to dry these minces. At higher salt concentrations, the water-holding capacity of the mince is destroyed and, therefore, it is easier to dry but, on the other hand, the gelling capacity of the salt and protein in the muscle is destroyed and the mince will not form cakes using a hand press. The main difference between fish of different salt concentrations as far as the consumer is concerned is in the area of the textural changes which occur. At salt concentrations below 15 per cent, a cohesive mass of fish is produced and it is difficult to remove the salt from the finished dried cake. With fish treated with higher concentrations of salt, a spongy open-textured cake is formed from which the salt can be easily removed. In practice, therefore, higher salted cakes have, after leaching of the water prior to final cooking, lower salt concentrations than the salted mince fish cakes that originally had lower salt concentrations (See Table 1).**

Dried salt/cake*	Salt (% dry weight)		% Salt removed
	Before	After	
5% salt	17.6	10.6	39.8
10% salt	30.0	13.5	55.0
15% salt	36.8	4.5	87.7
20% salt	43.7	2.9	95.4

\*Salt content refers to that added to the mince.

**Table 1 Salt content of salt/chambo cakes before and after de-salting**

## **Delicatessen products**

### **Fish sausage**

**There are many sorts of sausage that can be produced using fish. Most recipes are based on recipes for meat sausages where the meat portion is replaced by fish.**

### **Frying sausage**

**The ingredients for this sort of sausage include white fish fillet meat, pork fat, rusk, water, salt, coriander, polyphosphates, pepper, and dye if required. The fillets are chopped in a chopper until the flesh is finely mashed. The other ingredients are added and the chopping is continued for 4 - 5 minutes. The mixture is then filled into edible sausage casings and then twisted into sausages of the lengths required. The product resembles a normal frying sausage in appearance and in taste; it is perishable and should be kept chilled or frozen. The sausages must be cooked before being eaten: they can be fried, grilled or cooked in the same way as meat sausages.**

### **Slicing sausage**

**This product resembles a polony sausage. Although it is cooked and ready to eat cold, it**

**can if desired be fried. The ingredients are as follows: skinless white fish fillets, pork fat, water, rusk, salt and pepper, powdered cereal filler, and cayenne pepper. The fillets are chopped in a bowl chopper until finely mashed, then the other ingredients are added to the bowl and mixing continues for another 5 minutes. The sausages are then filled into cellulose casings and tied off. The sausages are then heated for 2 hours in water at 80 - 90°C. To prevent bursting, the water temperature must not rise above 90°C. The sausages are then cooled in iced water for half an hour. The product should be kept chilled or frozen but will keep for longer than a year when frozen and stored at - 30°C.**

**A variation on the above recipe can be made inasmuch as the fish sausage once prepared can be smoked to produce a smoked slicing sausage.**

### **Frankfurter sausage**

**This product is similar to a frankfurter made with meat. It is only partially cooked during the process and must be cooked by the consumer before it is eaten. The ingredients for these sausages are similar to those for slicing sausages but the proportions are different. Following production, the sausages can be smoked for 3½ hours at 60°C in a mechanical kiln to give them a smokey flavour. They are usually then skinned prior to sale. An acceptable fish sausage can be produced using fish which have been smoked, such as kippers. It is more usual, however, to use nonsmoked fish such as herring to produce a normal sausage and then to hot-smoke the sausage to give it a kippery taste.**

### **Kamaboko**

**Kamaboko is a traditional Japanese fishery product which may be likened to a meat loaf or a sausage without casing. It can be made in various sizes and shapes. The first procedure in the manufacture of kamaboko is the manufacture of a product known as surimi which is a paste or a dough. The prime requirements for making surimi is that the minced fish meat must be elastic. In the main, croakers, lizard fish and conga eel have the desired elasticity.**



**White croakers (*Nibea argentata*) are generally favoured because the kamaboko made from this fish is highly elastic. The other raw materials, apart from fish, include potato or wheat starch, salt, sugar, ajinomoto or monosodium glutamate, chopped vegetables (carrot and burdock) and vegetable oils (if the product is fried).**

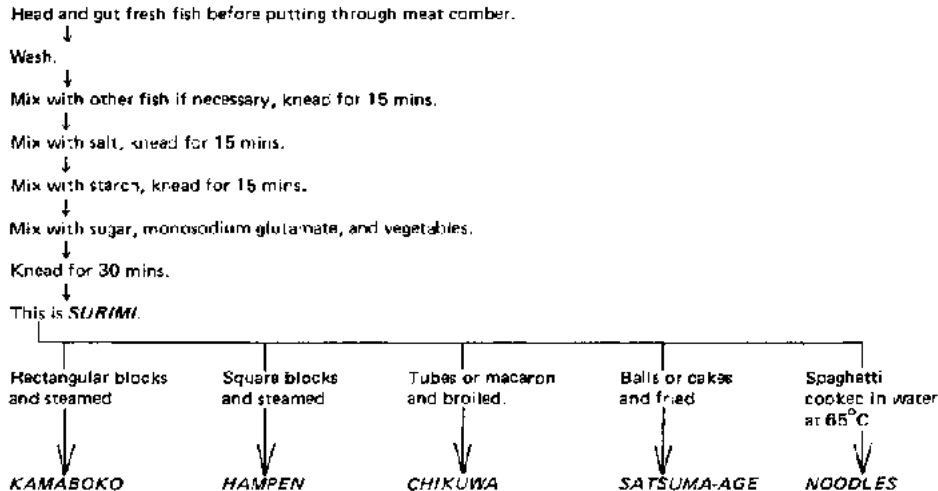
**The preparation of surimi is as follows:**

- 1. The head, scales and viscera are removed.**
- 2. The flesh is cut into single fillets.**
- 3. The bones and skin are removed. This can be done either manually or in a machine.**
- 4. The meat is washed three times in drums of fresh water to remove the fat. Different kinds of fish may be mixed with the main species at this stage.**
- 5. Excess water is removed either in a basket centrifuge or by squeezing through a cloth.**
- 6. The meat is kneaded in a machine for about 15 minutes.**
- 7. Salt is added to the meat and the mixture kneaded for a further 15 minutes; 20 - 40 g of salt/kg are normally used.**
- 8. Potato or wheat starch is added (100 - 250 g/kg of fish) and the mixture kneaded for a further 15 minutes.**
- 9. Sugar may be added at the rate of 30 - 100 g/kg of meat to improve the flavour; monosodium glutamate is added and the mixture kneaded for a further 20 - 30 minutes until it assumes a doughy consistency. Chopped vegetables may be added if desired during the latter stages.**

**The resulting surimi is a stiff paste. The yield is around 40 per cent of the whole fish.**

**To produce kamaboko, the surimi must be shaped into half cylinders or into the shape of bread loaves on wooden blocks. The loaves are cut manually into pieces approximately 200 g each and subjected to infra-red ray treatment, or they may be roasted on the top to get a brown crust similar to bread. They may then be dipped into dilute hydrogen peroxide to sterilise them. The product is then steamed for 40 minutes at a temperature of about 80°C and then cooled for 2 hours in the air. Packaging is in cellophane or polyethylene which is heat sealed. The products can keep for about one week during warm times of the year and up to two weeks in winter.**

**There are many variations on the basic kamaboko product, the main ones being in size and shape. Hampen is square-shaped and chikuwa is like a tube that is broiled instead of being steamed. There are also products such as fish noodles which are by-products of the kamaboko plant since the process is very similar except that the surimi is extruded through a vermicelli or spaghetti machine (See the flow sheet).**



### Flow sheet for the manufacture of kamaboko and allied products

#### Tuna ham

Fresh or frozen tuna, marlin, swordfish, whale meat, pork, salt, spices, wheat or potato starch, and a natural casing are the main ingredients of tuna ham which is produced in Japan. Tuna ham is really a smoked fish sausage similar to salami but cut into thin slices.

The tuna, whale meat and pork are cooked at 86°C and minced. The minced meats are mixed with the salt, sugar, starch and spices in a mechanical mixer and kneaded well for about half an hour. The mixture is put into large-size natural casings and smoked over smouldering oak chips for about 12 hours. The smoked ham is then cut by machine into thin slices and vacuum packed in polyethylene-cellophane bags. The ham will keep for about 10 - 14 days at room temperature.

## **Fish balls**

**In China, low price fish such as sharks and lizard fish are used to produce fish balls. The meat is removed from the skin and bone and ground to a paste with water added. Ingredients such as starch, sugar, flavour essence, salt, water and spices are added and the balls are formed either by hand or by machine. Once formed they are put into cold water for a short time and then cooked for 15 minutes in boiling water.**

## **Fish crisps**

**Fish crisps, shrimp crackers or krupuk in Indonesia are produced in considerable amounts. The product is also available in Thailand where it is made from fish. In Indonesia, the product is known as krupuk udang or shrimp krupuk. The krupuk industry is concentrated in East Java.**

**Shrimp or fish are used but the product made from white shrimp is more popular and higher priced than the others. The fish material should be absolutely fresh. Tapioca flour, sugar and salt are required. Eggs may also be added. To produce 100 kg of krupuk the following amounts of raw materials are required:**

Shrimp meat	100 kg
Tapioca flour	100 kg
Sugar	200 g
Salt	5 kg
Water	25 litres
Eggs	100

**The fish or shrimp are mixed with tapioca flour in various proportions depending on the**

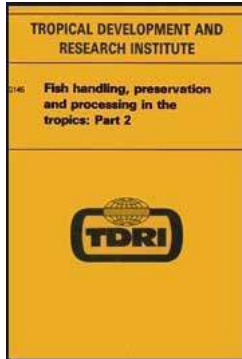
**quality of the product desired. The best quality contains at least as much shrimp as tapioca. Lower grade products may contain much less shrimp and may be as low as one part of shrimp to ten of tapioca. The mixture of shrimp meat and tapioca is either pounded with wooden poles in a stone mortar for 1 - 2 hours or mixed mechanically. Machine mixing is not favoured in Indonesia as the product develops a slightly darker colour. During pounding or mixing of the shrimp meat and tapioca, the other materials such as sugar, salt and eggs are also added and mixing continues after addition of water. When mixing is complete the material forms a paste. This paste or dough is put into metal moulds in the shape of half cylinders; the filled moulds are placed in racks in a boiler containing some water. The moulds are exposed to steam but not immersed in the water. The steam gelatinises the starch and coagulates the proteins of the shrimp meat. Steaming continues for about 3 hours. After steaming the moulds are separated and the blocks of cooked fish/tapioca dough are allowed to cool for 2 - 4 hours. When cooled, they may be sliced in a machine to a thickness of 4 - 7 mm. The slices are then dried in the sun. The product is packed in paper cartons of different sizes depending on consumer requirements.**

**Krupuk is fried in oil before being eaten. This makes it expand several times and it is used as a side dish in Indonesian, Chinese and Thai cookery.**

## **References**

- 1. SUBBA RAO, G. N. (1961) Fisheries Products Manual. Food and Agriculture Organization of the United Nations, Rome (FAO). Indo-Pacific Fisheries Council.**
- 2. TORRY RESEARCH STATION (1970) Torry Advisory Note No. 43, Torry Research Station, Aberdeen.**





## **Fish Handling, Preservation and Processing in the Tropics: Part 2 (NRI)**

 **(introduction...)**

 **Summaries**

 **Acknowledgements**

 **Introduction**

 **Salting of fish: salt**

 **Salting of fish: methods**

 **Drying of fish: basic principles**

 **Drying of fish: methods**

 **Smoking of fish**

 **Marinades**

 **Fermented fish products: a review**

 **Boiled fish products**

 **Fish canning: theory and practice**


 **Freeze drying**

 **Irradiation**

 **Miscellaneous products: crustaceans**














 **Miscellaneous aquatic products used as food**

 **Food by-products**

 **Non-food by-products**

 **New and delicatessen products**

 **➔ Fish meal**

-  **Fish silage**
-  **Chemical and physical methods of quality assessment**
-  **Organoleptic (sensory) measurement of spoilage**
-  **Microbiology of spoilage**
-  **Microbiology of fish spoilage**
-  **Public health microbiology**
-  **International standards for fisheries products**
-  **Large-scale fish landing facilities**
-  **Small-scale landing facilities: design and operation**
-  **Retail sale facilities**
-  **Fisheries extension services: their role in rural development**
-  **Training in the field**
-  **Appendix**

## **Fish meal**

**The fish meal and oil industry began during the early 1800s in northern Europe and North America based primarily on surplus herring catches. The early industry was geared to the production of fish oil for the leather and soap industries with the solid residue being used as a high nitrogen and phosphorus fertiliser. More recently the solid residue, or meal, has become too expensive for use as a fertiliser and the high protein content makes it very suitable as an animal feedstuff. At present the bulk of the world's production of fish meal is used for incorporation into compound feeds for livestock such as poultry, pigs and fish. The world fish catch is in the region of 70 million tonnes per annum of which about one third is used for the production of fish meal.**

## **Raw material**

**The raw material used for production of fish meal can be divided into three main categories:**

- 1. Fish caught for the sole purpose of fishmeal production (often referred to as 'industrial fish'), e.g., anchovies in Peru, anchovies and pilchards in South Africa, herring and capelin in Norway and Denmark, and menhaden in America.**
- 2. The 'by-catch' from other fisheries, e.g., prawn by-catch.**
- 3. Fish offal and fish wastes from processing operations, e.g., carcasses from a filleting operation, heads and guts from a canning line etc.**

**It is extremely important when planning the establishment of a fishmeal industry that a realistic estimate is obtained of the raw material available. Many fishmeal operations have failed because of over-optimistic assessment of the raw material available. In general, because of the high capital investment, running costs etc., a meal plant requires a regular large supply of fish to be economically viable. It is also very necessary to assess the price of the raw material and seasonal fluctuations in supply. Additional factors, such as the situation and distance from landing places etc., must also be taken into account.**

**It is also important to have information on the suitability of the raw material for meal manufacture. A number of tropical species of fish are known to contain toxins which could be harmful to livestock. If such toxic fish are likely to be included in the catch, it is important to carry out preliminary feeding trials to establish the suitability of the meal for livestock production.**

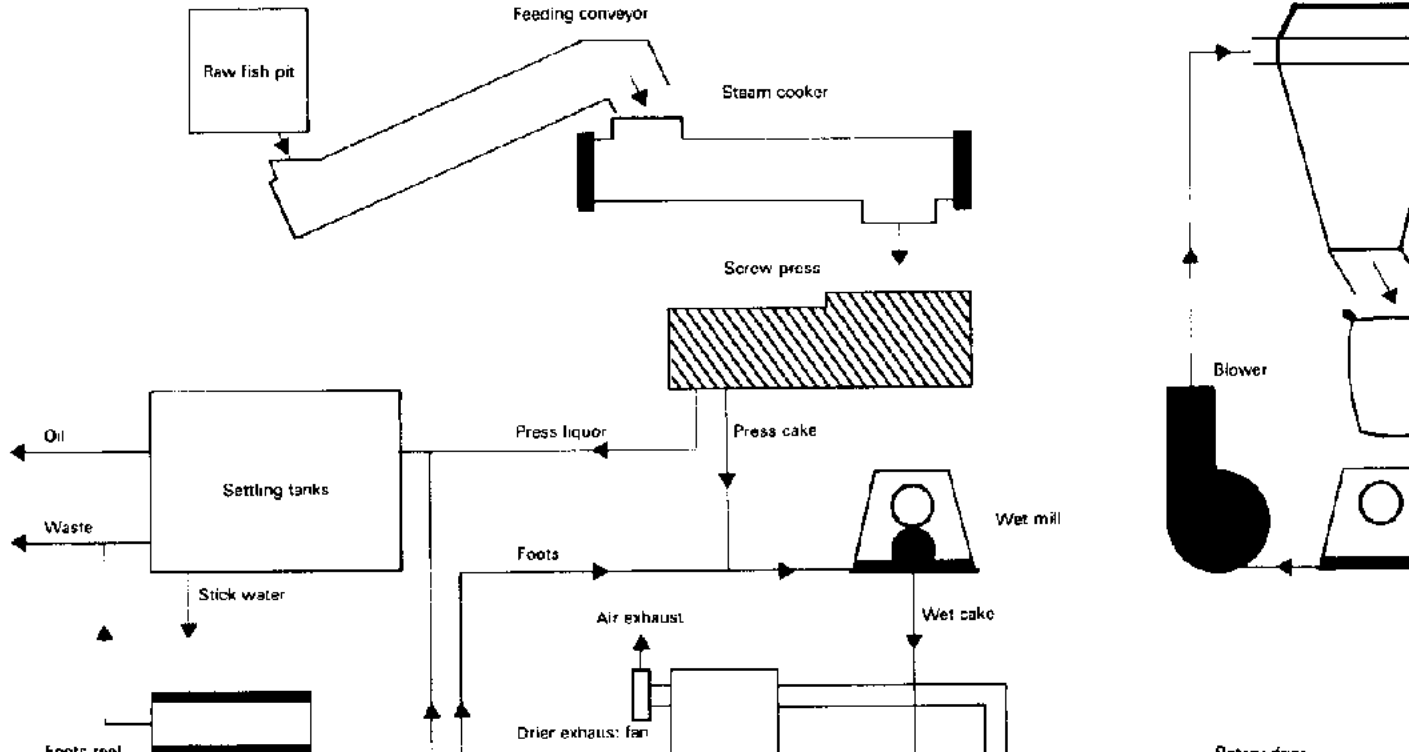
**The fat content of the raw material to be used for meal manufacture is also an important factor in determining the type of processing equipment necessary, the economics of production and the nature of the final product. Fish are normally grouped into two categories, namely oily (or fatty) fish of more than 2.5 per cent fat and non-oily (lean or**

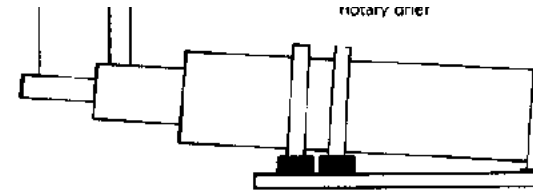
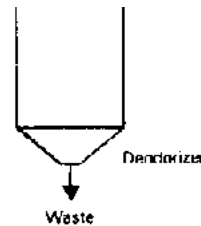
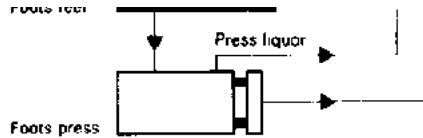


white fish) with a fat content of less than 2.5 per cent.

**Production methods**

There are two main methods and many minor variations of commercial fishmeal production but all have the following steps in common (See Figure 14).





**Figure 14 - Generalised fish meal plant showing process sequence**

- 1. Heating or cooking to coagulate protein and release water and oil.**
- 2. Pressing to separate liquids from solids.**
- 3. Drying.**
- 4. Grinding to produce a powdered or granular end product.**

### **Wet reduction**

The wet reduction process is used primarily for the production of meal from fatty fish such as menhaden, herring, pilchard, anchovy etc., which are caught specifically for fishmeal production. The process is a continuous rather than a batch process and is particularly suitable for large-scale operations. The essential steps in the wet reduction process are as follows:

- 1. Grinding or hashing of large fish.**
- 2. Cooking and heating usually with steam.**
- 3. Pressing to squeeze out water and oil. The liquid portion is known as press liquor and is passed through a screen to remove solid particles of fish which are then returned to the press cake.**

**4. Fluffing out of the press cake.**

**5. Drying the press cake.**

**6. Grinding and packing the dried meal.**

**The press liquor can be treated, after screening to remove solids, in a number of different ways; generally, however, the liquid is heated and centrifuged to remove the suspended solid particles and the oil. The oil may then be further refined or polished whilst the solids are returned to the meal plant for drying. The liquor or stickwater can be concentrated by evaporation of the water to about 50 per cent solids. The concentrated liquor can either be sold separately as concentrated solubles or returned to the meal plant and incorporated into the press cake for drying.**

**Dry rendering or reduction of fish meal**

**The dry reduction process is principally applied to the conversion of fish or fish offal of low fat content. It is a batch process and is easier to manipulate than the wet rendering continuous process.**

**The essential steps in the dry reduction process are as follows:**

**1. Fish are coarsely ground in a hacker or grinder.**

**2. The hacked fish are cooked in a steam jacketed cooker with a stirrer. The cooker also acts as a drier and is usually referred to as a cooker/drier.**

**Presses and separate driers are optional extras with this type of plant. The cooker/ drier may be operated at atmospheric pressure or under slight vacuum to facilitate drying. The cooker will handle only one charge at a time. In recent years, the dry reduction process**

**has gone out of favour for a number of reasons.**

### **Advantages and disadvantages of the two methods**

#### **DRY RENDERING**

<b>Advantages</b>	<b>Disadvantages</b>
1 High yield of oil even for non-fatty fish.	1 Oil of inferior quality.
2 Suitable for small batch operation.	2 High installation and operating costs.
3 Easy to manipulate cooking/drying times.	
4 Greater flexibility.	3 Production is slow.
5 Produces whole meal including solubles.	

#### **WET RENDERING**

<b>Advantages</b>	<b>Disadvantages</b>
1 Good quality oil produced.	1 Meal is low in water solubles
2 Faster process.	unless concentrated stickwater is
3 Lower installation and operating costs.	added back.
4 Suitable for processing large quantities	2 Lower yield.
Of material.	3 Rigid operation conditions.
5 Can yield a valuable by-product, i.e. fish solubles.	

#### **Cooking**

**For successful operation of a meal plant, the cooking step is one of the most important. If**

**the time and temperature of cooking is insufficient the fluids (oil and water) will not be released from the protein and pressing out will be difficult. If the material is over-cooked, however, the fish become a soft mush and sufficient pressure will not build up in the press to expel the liquids.**

### **Oxidation and antioxidants**

**Fish meals with high oil contents can present problems during storage. Fish oil in the meal will oxidise after production and the reaction can lead to considerable rises in temperature. This can become a fire hazard. One method of overcoming this problem is to allow the oil to oxidise before packing by holding the meal in bulk stacks or spread out on the floor. Sacks of meal can also be stacked singly for a few weeks while oxidation occurs. These procedures allow dissipation of the heat generated by oxidation rather than allowing it to build up in confined spaces. Another way of overcoming this problem is to pack the meal in airtight, polyethylene laminated multilayer sacks which will hamper the diffusion of oxygen into the meal.**

**The use of antioxidants to stabilise fish meals is common these days. The amount of antioxidant required depends on the degree of unsaturation of the oil and varies with fish species. The two most common antioxidants used for fish meal are ethoxyquin and butylated hydroxytoluene (BHT). It is common practice to add between 400 and 700 ppm ethoxyquin to fish meal immediately after drying and prior to packaging. The antioxidant will prevent the uptake of oxygen by the meal and so prevent spontaneous heating.**

### **Bags and storage**

**Fishmeal bags normally contain 50 kg. In tropical areas, the bag material is often hessian made from woven jute. This relatively open structured material allows the passage of water vapour and oxygen. Under humid conditions, the meal which is hygroscopic may absorb moisture and, if the moisture content rises above 15 per cent, moulds and bacteria**

**may become active and the meal will compact into a solid lump in the bottom of the bag.**

**In many modern fishmeal operations, paper and polyethylene laminated sacks are used. These sacks have advantages over the more traditional hessian ones in that:**

- 1. They prevent the rapid movement of oxygen and water.**
- 2. To some extent the meal is protected from rodents and insect attack and from contamination by moulds and bacteria.**
- 3. The meal cannot seep from the sack as it can through hessian.**

### **Pollution**

**Fishmeal production can pollute the environment in two ways: firstly, from vapours arising primarily during the drying stage and, secondly, from liquid effluent from the washing down of plant etc.**

**Air pollution, which is not in fact harmful, is most easily noted by the public and can often be a source of embarrassment and a problem area for a meal factory. There are a number of ways of eliminating the malodorous vapours but the following should be considered:**

- 1. The volume of gases to be dealt with.**
- 2. The freshness of the raw material.**
- 3. The drying method used.**
- 4. The location of the plant.**

**The methods used for abatement include:**

- 1. Scrubbing the vapours by passing them through water.**

**2. Chemical inactivation, using chlorine or permanganate to oxidise the volatile reducing substances which are the main odour producing substances involved.**

**3. Combustion of the gases either at high temperatures or at lower temperatures using a catalyst.**

**In most cases, these methods are used in combination with the primary reduction of odorous gases with a scrubbing tower followed by a chemical or combustion stage. In many instances, the chemical reduction is incorporated into a scrubber by the addition of chlorine or permanganate to the scrubbing water.**

**Water pollution may be reduced by the use of screens and settling tanks and by the adjustment of the pH in the effluent to flocculate the protein solids. These proteinaceous solids may then be removed and recycled into the plant.**

### **Composition and quality**

**Fish meal is a high protein feed supplement which is mixed with other feed supplements to produce a balanced diet for livestock.**

**Constituents of the meal vary depending on the type of raw material and the process used. Protein is generally around 65 per cent but can vary from 50 per cent to 75 per cent. Fat content may vary between 5 and 10 per cent but preferably should be below 8 per cent. Ash or mineral content can vary considerably between 12 and 33 per cent depending on the raw material. High protein/whole fish meals tend to have lower mineral contents than meals produced from scrap and filleting waste: 18 per cent ash is the norm. Moisture content should be about 8 per cent (6 - 10 per cent); at moisture contents of 12 per cent or above, moulds may grow. Crude fibre is generally below 1 per cent and fish meal is considered as a low-fibre feed.**

**In the trade, fish meal is evaluated on the basis of its crude protein content. Prices are often given as price per unit protein (the unit of protein being the percentage of protein per tonne of meal). This means that if a plant produces a meal with say 60 per cent protein and the price quoted is \$7 per unit, the price per tonne of that meal will be  $60 \times \$7/\text{tonne}$ , i.e. \$420 per tonne. The protein in fish meal is particularly good as a source of the essential amino acids. Most meals contain sufficient quantities of all 10 essential, and the 11 non-essential, amino acids to produce a well balanced diet. Of the essential acids, lysine is often the most critical. Lysine which can be high in fish meals can also be destroyed at high temperatures. Cereal-based diets which are used in feed rations are often deficient in lysine and fish meal can be the sole source for a balanced feed.**

**Although fish meal is particularly valuable as a source of protein for livestock, it also contains useful quantities of other nutrients. Fish meals contain considerable quantities of vitamins, particularly the B group. These days, most mixed feeds incorporate a vitamin supplement formulated to include vitamins in sufficient quantities. However, the intrinsic vitamin content of fish meal leads to a good security margin in most feeds.**

**Fish meals can also be an important provider of minerals. Of particular interest to feed formulators are calcium, phosphorus, sodium, magnesium, potassium, iron, copper, zinc, manganese, iodine and selenium which can be deficient in a mixed diet. The following table gives the mineral contents of some fish meals and the mineral requirements for chickens and pigs:**



Element	Peruvian anchovy	Norwegian herring	White fish	Menhaden	Chicken requirements	P g requirements
Ash (%)	15.4	10.1	20.0	18.0		
Calcium (%)	3.95	1.95	8.0	5.26	1.0	0.75
Phosphorus (%)	2.60	1.50	4.8	2.98	0.7	0.5
Sodium (%)	0.87	0.42	n.a.	0.34	0.15	0.2
Magnesium (%)	0.25	0.11	0.15	0.14	0.05	(0.04)
Potassium (%)	0.66	1.20	0.9	0.72	0.2	(0.25)
Iron (ppm)	246	150	300	438	80	70
Copper (ppm)	10.6	5.4	7	11.4	4	6
Zinc (ppm)	111	120	100	151	50	50
Manganese (ppm)	9.7	2.4	10	35.6	55	20
Iodine (ppm)	n.a.	2.4	n.a.	n.a.	0.35	0.22
Selenium (ppm)	1.39	2.78	1.60	2.22	0.1	—

n.a.: not available  
(from Barlow, 1973)

### Table Important provider of materials

From the above table, by examining the mineral requirements of chickens, it can be seen that feeding 10 per cent Peruvian anchovy meal meets 40 per cent of the bird's calcium and phosphorous requirements and all the selenium needs. With the exception of manganese, this percentage of fish meal would also fulfil up to 50 per cent of the bird's requirements for the trace minerals.

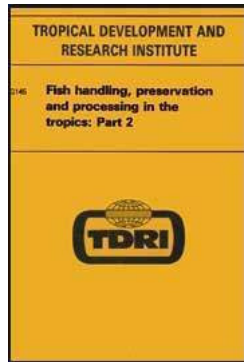
Prior to 1948, there was no doubt that fish meal contained an unknown growth factor which was termed the 'animal protein factor' (APF). This factor was found not only in fish meal but in many animal protein feeding stuffs. Vegetable matter did not possess this factor and, although poultry could be kept for some considerable time on 'all-vegetable' diets, they failed to survive in isolated cages for more than one complete generation. Subsequently, intensive research led to the isolation from ox liver of vitamin B12, which was shown to be the APF. Addition of vitamin B12 to all-vegetable rations improved the performance of these diets considerably, particularly with respect to growth and reproduction. Even with the presence of this vitamin in all-vegetable rations, however, the

**addition of fish solubles to the diet still resulted in increased growth. By a series of experiments conducted around 1955, it was discovered that fish solubles were a rich source of zinc, and this mineral was deficient in all-vegetable rations. Apparently the soyabean protein had the property of binding zinc and so increased the requirement for it several times.**











**These two examples illustrate the important role that the micronutrients in fish meal and fish solubles have played in ensuring high performance in livestock. However, in the light of modern understanding of the nutritional requirements of livestock, fish meal still possesses unknown dietary factors which improve performance. The scientific literature on this question is extensive and clearly this is not the place to review it.**



[Home](#) > [ar.cn.de.en.es.fr.id.it.ph.po.ru.sw](#)



## **Fish Handling, Preservation and Processing in the Tropics: Part 2 (NRI)**

-  **(introduction...)**
-  **Summaries**
-  **Acknowledgements**
-  **Introduction**
-  **Salting of fish: salt**
-  **Salting of fish: methods**
-  **Drying of fish: basic principles**
-  **Drying of fish: methods**
-  **Smoking of fish**
-  **Marinades**

-  **Fermented fish products: a review**
-  **Boiled fish products**
-  **Fish canning: theory and practice**
-  **Freeze drying**
-  **Irradiation**
-  **Miscellaneous products: crustaceans**
-  **Miscellaneous aquatic products used as food**
-  **Food by-products**
-  **Non-food by-products**
-  **New and delicatessen products**
-  **Fish meal**
-   **Fish silage**
-  **Chemical and physical methods of quality assessment**
-  **Organoleptic (sensory) measurement of spoilage**
-  **Microbiology of spoilage**
-  **Microbiology of fish spoilage**
-  **Public health microbiology**
-  **International standards for fisheries products**
-  **Large-scale fish landing facilities**
-  **Small-scale landing facilities: design and operation**
-  **Retail sale facilities**
-  **Fisheries extension services: their role in rural development**
-  **Training in the field**
-  **Appendix**

## **Fish silage**

**An interest in fish silage is related to the desire to make maximum use of waste fish and fish offal in situations where the quantity involved, or the transport costs, prohibit conversion into fish meal. In small-scale fisheries in the tropics, this situation is common. Daily and/or seasonal gluts of fish occur and, because of transport difficulties and inadequate processing facilities, these surplus fish are often underused. The quantities involved do not permit profitable fishmeal manufacture since even the most modest fishmeal plant requires regular supplies of several tonnes of raw material per day for viable operation. Ironically, countries in this situation are often importing substantial quantities of fish meal to support their expanding animal production industries.**

**In countries where investment capital is available and fish waste is concentrated in one area, the obvious solution is reduction to fish meal. Where this is not possible, the fish could be utilised by the cattle, pig and poultry industries in the form of silage. The technology of fish silage production is simple; essential equipment is cheap; and the scale of production may be varied at will. These are distinct advantages in developing countries.**

**Silage production relies on the fact that at acidic pH, the microbial flora of fish is eliminated or greatly reduced and the enzyme systems in the fish which break down fish protein are able to function more efficiently. Fish silage methods can be divided into two major groups:**

- 1. those employing acids, either mineral and/or organic, to lower the pH and to produce the conditions necessary for silage production, and**
- 2. those employing a process of fermentation with the generation of organic acids to conserve the product.**

## **Acid ensilage**

**The acid ensilage of fish offal was developed originally from a method invented by A. 1. Vertanen in the 1920s. Sulphuric and hydrochloric acids were used to acidify fish waste and the product was neutralised with chalk. Methods using organic acids, where the pH can be higher and neutralisation is unnecessary, have also been investigated. In the preparation of acid silage, the choice of preservative is between a mineral acid, mineral acid mixtures, organic acids such as formic or propionic, or mixtures of inorganic and organic acids. The choice will depend upon the cost and availability of the acids and the conditions under which the product is prepared. Formic acid is usually more expensive than the common mineral acids but it produces silages which are not very acidic and which do not require neutralisation before use. Care must be exercised with silages made from mineral acids and with all acids in the concentrated form. Equipment, tanks and machinery used for the production or storage of silage must be acid-resistant. Formic acid is not only acid in nature but it also has bacteriocidal properties which means that the quantities required are less than if mineral acids alone are used. It has already been said that the preparation of fish silage is a fairly simple process. An outline of the steps involved in preparation is as follows:**

- 1. The raw material should be as fresh as possible (this may include whole fish, filleting waste, offal or other suitable protein material).**
- 2. The fish are comminuted by mincing, cutting or chopping (this operation may be manual or mechanical).**
- 3. For manual preparation 10 - 15 kg quantities of minced fish are placed in a suitable container (this must be acid-resistant).**
- 4. The minced fish is acidified with mineral acid or with formic acid to the required pH. The mix is constantly stirred until the desired pH is reached.**

**Note: The optimum amounts of mineral acid to lower the pH and formic acid must be**

**determined by experiment if they are used in combination. Generally, addition of sufficient mineral acid to reach pH 3 plus 0.5 per cent formic acid has been found to be acceptable in many situations. If formic acid is to be used alone, a concentration of 3 per cent formic acid by volume to weight of fish seems to be acceptable.**

**5. The container is left, preferably covered, for the fish mix to liquefy. This can take 3 or 4 days but the rate depends on the species of fish and the degree of comminution as well as the temperature at which the mixture is kept. It should be stirred daily.**

**Experience in the UK has shown that the successful production of fish silage, irrespective of scale, requires certain conditions:**

**1. The material should be reduced in size preferably to pieces no larger than 3 - 4 mm in diameter.**

**2. Acid must be thoroughly dispersed throughout the minced fish to avoid pockets of untreated material where bacterial spoilage can continue.**

**3. Periodic agitation is necessary to bring about rapid liquefaction.**

**4. Temperatures of at least 20°C are desirable since, below this, liquefaction takes place rather slowly. The enzymes responsible for liquefaction can be inactivated at higher temperatures but samples heated to 40°C have been found to liquefy rapidly.**

**Equipment used for silage production can vary considerably and, on a small scale, it might be sufficient to pulp the raw material, add the acid manually, mix in a suitable container, and store in a warm place. For larger-scale production, however, a mincer capable of reducing material to the required size is necessary, together with suitable heavy-duty mixing equipment, to ensure that a uniform mixture of fish and acid is made. For safety, a pump or measuring device for handling the acid is advisable. Suitable tanks are required**

**for initial liquefaction of the fish, together with other tanks for bulk storage of the finished product and formic acid.**

**After liquefaction, oil removal may be necessary where fish with a high fat content are used. To do this, it is necessary to raise the temperature of the silage to 65 - 70°C when coarse suspended solids can be removed by decantation; this is followed immediately by centrifugation to remove the oil. In many situations, this process would be too costly and it may be possible to skim a certain amount of the oil from the top of the silage but experience has shown that oil is generally emulsified and that the formation of a distinct easily separated fraction does not occur.**

**The liquid nature of fish silage has always presented difficulties in the transportation and distribution of the product. Where production is for a local pig farm, then this may not matter but, where the silage is to be moved long distances or be fed to livestock which require a dry food e.g. poultry, there may be problems. Recent work at TPI has concentrated on the production of a dry product. The liquid silage is mixed with a powdered or granular carbohydrate source (cassava, wheat meal, rice, bran etc) which absorbs some of the moisture and makes it possible to sun dry the resultant paste. The end product is a dry powder or granular material which contains not only nitrogenous protein constituents but also an energy source from the carbohydrate added. This dry material can be sacked or bagged and is much easier to handle than the straight liquid fish silage.**

### **Fermented silages**

**Fermented fish silages rely on the biological production of lactic acid by bacteria to lower the pH. In general, lactic acid bacteria such as *Lactobacillus plantarum* ferment sugars to organic acids (primarily lactic), thus lowering the pH of the mixture.**

**Fish contain only small quantities of fermentable carbohydrates and it is usually necessary**

**to add suitable carbohydrates for the bacteria to convert to acid. Addition of mixtures of malt and cereal meal, molasses and cereal meal, malt and tapioca meal, and molasses and tapioca meal have all proved successful.**

**The fermentation process for conversion of carbohydrate to lactic acid is anaerobic and can be divided into three stages:**

- 1. The starch of the carbohydrate source is hydrolysed to maltose by alpha and beta amylase.**
- 2. Maltose is broken down to glucose by maltase.**
- 3. Glucose is converted to lactic acid by bacteria. Small amounts of other substances such as acetic acid and alcohol are also formed.**

**Lactic acid bacteria can be divided into two types: (a) homofermentative, which convert one molecule of glucose to two of lactic acid, and (b) heterofermentative, which convert one molecule of glucose to one molecule of lactic acid plus ethyl alcohol and water. It is, therefore, better to use a homofermentative bacterium if possible. Since fish do not contain many lactic acid bacteria themselves, it is essential to add a starter culture, usually of lactobacilli, for successful fermentation. In addition, it is also necessary to add a source of amylase since the first step in the fermentation relies on the hydrolysis of carbohydrate. In most processes, the amylase is provided by the addition of malt to the mixture since malt is a rich source of amylases.**

**In essence, the production of fermented silage requires that the fish be comminuted in the same way as for acid silage. A carbohydrate is then mixed with the fish and a starter culture of a suitable bacterium added.**

**The fermentation should be carried out in full airtight containers so that conditions are**

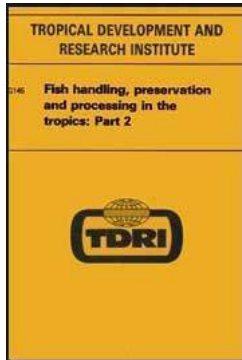


**anaerobic and successful fermentation is indicated by a rapid drop in pH, as the lactic acid is formed, and the production of gas. The anaerobic conditions may encourage the growth of Clostridium spp. which could be of public health significance; however, if the conditions are allowed to become aerobic, yeasts capable of growth at low pH may develop resulting in the loss of protein.**

**There are other methods used for production of fermented fish products which use other micro-organisms and/or salt. These are covered in the chapter on fermented fish products.**



[Home](#) > [ar.cn.de.en.es.fr.id.it.ph.po.ru.sw](#)



## **Fish Handling, Preservation and Processing in the Tropics: Part 2 (NRI)**

 **(introduction...)**

 **Summaries**

 **Acknowledgements**

 **Introduction**

 **Salting of fish: salt**

 **Salting of fish: methods**

 **Drying of fish: basic principles**

 **Drying of fish: methods**

 **Smoking of fish**

 **Marinades**

 **Fermented fish products: a review**

-  **Boiled fish products**
-  **Fish canning: theory and practice**
-  **Freeze drying**
-  **Irradiation**
-  **Miscellaneous products: crustaceans**
-  **Miscellaneous aquatic products used as food**
-  **Food by-products**
-  **Non-food by-products**
-  **New and delicatessen products**
-  **Fish meal**
-  **Fish silage**
- ➔  **Chemical and physical methods of quality assessment**
-  **Organoleptic (sensory) measurement of spoilage**
-  **Microbiology of spoilage**
-  **Microbiology of fish spoilage**
-  **Public health microbiology**
-  **International standards for fisheries products**
-  **Large-scale fish landing facilities**
-  **Small-scale landing facilities: design and operation**
-  **Retail sale facilities**
-  **Fisheries extension services: their role in rural development**
-  **Training in the field**
-  **Appendix**

## **Chemical and physical methods of quality assessment**

### **Attributes of the hypothetical ideal method**

**Over the years many different methods have been developed and investigated in an attempt to find the most suitable index for use in quality control testing. The 'ideal' method would have the following attributes:**

- (a) It would be non-destructive.**
- (b) The equipment would be cheap to purchase and maintain.**
- (c) The equipment would be robust, portable and simple to operate and suited to minimum facility 'field' operations.**
- (d) It would produce consistent results on standard material.**

**Few methods even approach this ideal.**

### **Precautions applicable to any quality assessment operation**

- (a) Ensure that your sample of fish from the bulk truly represents the bulk.**
- (b) Ensure that, when a part of a fish is analysed, it is always the same part. As discussed previously, composition differs markedly from head to tail of true fish, and depends particularly upon the relative amounts of skin, dark muscle and light muscle that are in the sample.**
- (c) Ensure that a rigidly standardised method is employed. The result obtained frequently depends upon the analytical method employed. Accordingly, standards specifying grades related to the content of a particular component should also specify the method of obtaining the result.**

- (d) Never attempt to compare directly results obtained by different methods.**
- (e) In export operations, levels of acceptance and rejection must correspond to the importer's legislation and/or specifications.**
- (f) In local operations, levels of acceptance and rejection should be related to local requirements.**

### **Chemical methods**

#### **(a) Trimethylamine (TMA)**

**Trimethylamine,  $N(CH_3)_3$ , smells like ammonia and is chemically similar to ammonia,  $NH_3$ . It is produced by many spoilage micro-organisms from a compound known as trimethylamine oxide (TMAO),  $O=N(CH_3)_3$ .**

**This conversion can only occur if:**

- (i) TMAO is present**
- and**
- (ii) suitable spoilage micro-organisms are present.**

**TMAO is not normally present in freshwater fish but is found in marine species at a level related to the salinity of the habitat. The level of TMAO may change as a fish migrates from water of one salinity to another. High salinity is associated with high TMAO contents. It has been observed that freshwater fish may contain TMAO if they have been fed with fish meal made from marine species.**

Species	Caught at sea	Caught in backwater
<i>Penaeus indicus</i>	33–59	0–5
<i>Metapenaeus monoceros</i>	61–90	0

**Table 1 Variations in TMAO content (mg N/100g) in Indian prawns: effect of fishing ground salinity**

If TMAO is present in the muscle, then micro-organisms will normally invade postmortem and produce TMA, slowly at first, then with increasing rapidity in fish stored at ambient temperature, in ice or in refrigerated seawater.

Careful processing, e.g. heavy salting, salting and hot smoking, drying thoroughly, freezing, canning etc., either destroys or inhibits the TMA producing microorganisms and any TMA in such products was probably already present at the time of processing. If fish are stored or processed in contact with water or melt-water, some TMA will be washed out, masking the degree of spoilage. This occurrence is most pronounced in small prawns which have a large surface area in relation to volume.

Time of storage (hours)	TMA content (mg N/100 g)		Total produced
	In muscle	In melt-water	
7	1.45	—	1.45
24	0.86	0.31	1.19
48	1.32	2.09	3.40
72	1.21	5.11	6.32
96	0.42	5.76	6.18
120	0.67	8.84	9.51
144	0.83	12.28	13.11
168	0.46	16.66	17.31

Values adapted from Castro, L. A. B., *Boletim do Instituto de Pesca*, Santos 1975, 4, (2), 29–36.

**Table 2 The leaching of TMA from prawns (*Xiphopenaeus croyeri*) stored in ice**

Measurements of TMA are often used to assess the quality of fresh and frozen fish but the

**result obtained depends upon the method used: rigid standardisation is essential and it is unsound to make direct comparisons of results obtained by different methods. All methods require an acidic extract of the fish muscle and it is usually necessary to prevent interference by ammonia.**

**Simple methods of analysis:**

**(i) Conway microdiffusion or steam distillation. This method is relatively simple and uses relatively cheap equipment.**

**(ii) Trimethylamine sensitive electrode and pH meter. The assembly of equipment for this method is not yet commercially available; the capital cost probably approaches £1 000 but the equipment is cheap and simple to operate; it is essentially portable but a power supply is required; it is promising for the future.**

**More sophisticated methods of analysis:**

**(i) Measurement of the colour produced by treating TMA with picric acid. This method requires a colorimeter and mechanical sample shaking equipment, and a practised and conscientious operator.**

**(ii) Gas liquid chromatography. This method requires sophisticated equipment and a skilled operator; ammonia does not interfere.**

**Many workers feel that TMA content has only a poor correlation with eating quality, particularly in the early stages of spoilage. Typically, the presence of more than a trace is taken to indicate that spoilage has already occurred. It is not possible to use the TMA content to predict the remaining useful storage life.**

**(b) Total volatile nitrogen (TVN)**

**The abbreviation TVN refers to any volatile nitrogen-containing compounds that are produced post-mortem. The main components are TMA and ammonia. In a few species, dimethylamine is also produced e.g. Japanese hake (*Lutella* sp.). The relative amounts of these compounds depend upon the type of fish being examined and its quality. The following figures may be considered typical:**

- 1. Freshwater fish - almost entirely ammonia.**
- 2. Bony marine fish - ammonia equalling or slightly exceeding the TMA.**
- 3. Cartilaginous marine fish - ammonia usually markedly exceeding the TMA.**
- 4. Crustacean shellfish - ammonia usually more extensive than in bony marine fish but not as extensive as in cartilaginous marine fish.**

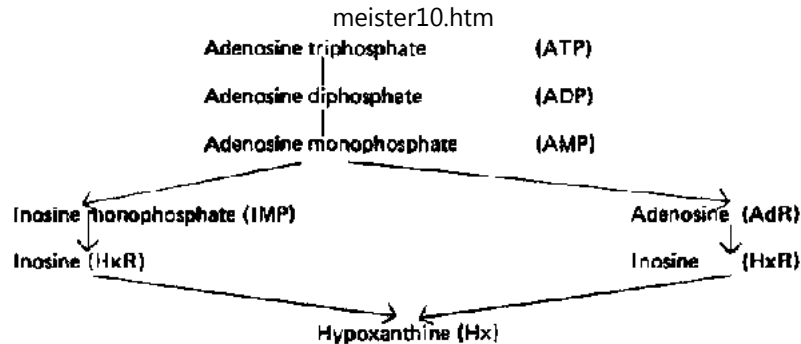
**TMA has already been fully discussed. The ammonia is mainly produced by bacterial attack on proteins and also by attack on amino acids (particularly arginine in crustacea) and on urea in cartilaginous species.**

**TVN determinations can be made by any of the methods mentioned for TMA but without the need to prevent interference by ammonia.**

### **(c) Nucleotide degradation products**

**Adenosine triphosphate (ATP) is the major nucleotide of living muscle. Post-mortem, it is degraded by enzymes that are naturally present in the muscle and probably by micro-organisms which have invaded the flesh. It is generally accepted that a measure of nucleotide breakdown is more closely related to eating quality than a measure of TMA or TVN, especially in the early stages of spoilage.**

**A full discussion of ATP breakdown is beyond the scope of this course, but the possible pathways are summarised below:**



**Figure**

**In crustacean species which are cooked alive, the degradation probably does not proceed beyond adenosine monophosphate. In a few species, degradation may occur via adenosine but, in the majority of species of commercial importance, degradation occurs via inosine monophosphate. The rate at which this degradation occurs is variable with species and with season, being markedly influenced by the pH value of the flesh. It is also influenced by temperature, occurring more rapidly above ambient temperature than in frozen storage. In most species, the final product is hypoxanthine but Japanese workers have reported that, in many Pacific species of commercial importance, inosine may be the final product (See Table 3).**

**Inosine monophosphate is considered to be a desirable component contributing to the characteristic flavour of fresh fish. In contrast, hypoxanthine is said to have an undesirable bitter taste. Opinion is divided about the taste of inosine but it is clear that nucleotide degradation involves at least a loss of a desirable component (IMP) and, in many cases, the accumulation of an undesirable component (Hx).**

**Hypoxanthine is not very soluble in water and so is not easily leached, as are TVN and TMA. It is essentially stable during processing and its presence in canned fish is indicative**



**of the pre-processing quality.**

**It has been observed that, for a given species, the rate of accumulation of Hx is proportional to the temperature of storage. If this rate is known, and the Hx concentration corresponding to the reject limit is also known, then the remaining useful storage life can be estimated by measuring the Hx content.**

**Simple methods of analysis:**

**(i) The simplest method is to use test papers that are dipped in an aqueous extract of fish and to compare the colour so generated with preestablished standards. The test papers contain the enzyme xanthine oxidase and the dyestuff dichlorophenolindophenol (DCPIP). This enzyme converts hypoxanthine to uric acid, at the same time bleaching the pink DCPIP. At present, these papers are not commercially available but may be prepared in a moderately equipped laboratory. They are stable if kept dry, and easily portable.**

**(ii) The older enzymic methods require more sophisticated equipment and use acidic protein free extracts. A colorimeter, or UV spectrophotometer, is required.**

**More sophisticated methods of analysis:**

**(i) Hypoxanthine may be precipitated by silver or barium salts and the precipitate recovered and weighed. This method is essentially simple but requires accurate balances and very careful operators.**

**(ii) Ion exchange resins may be used to separate individual nucleotides, and their degradation products, but this method is not suited to the analysis of a large number of samples. A modification is possible, permitting a separation of the degradation products into two groups: those containing phosphate and those which do not. The ratio of phosphate-free to phosphate-containing products may be used to calculate the K value. It**

is claimed by Japanese workers to be more useful than a Hx value for those species where degradation stops at inosine (See Table 3).

Macrid	<i>Nematonurus acrolepis</i>
Freshwater eel	<i>Anguilla japonica</i>
Round herring	<i>Etrumeus micropus</i>
Skipjack	<i>Katsuwonus pelamis</i>
Japanese anchovy	<i>Engraulis japonica</i>
Leatherfish	<i>Stephanolepis cirrifer</i>
Japanese black bream	<i>Mylio macrocephalus</i>
Bluefin tuna	<i>Thunnus thynnus orientalis</i>
Japanese spotted mackerel	<i>Pneumatophorus japonicus</i>
Yellow tail	<i>Seriola quinqueradiata</i>
Japanese red bream	<i>Pagrus major</i>
Big eyed tuna	<i>Parathunnus sibi</i>

Selected from:

Ehira, S. and Uchiyama, H., *Bulletin of the Tokai Regional Fisheries Research Laboratory* 1975, No. 76 p.63.

**Table 3 Pacific fish species known to yield inosine as the major nucleotide degradation product**

#### (d) Fat degradation products

Whether a fish contains a little or a large amount of fat, the degradation of this fat during storage can cause undesirable changes in flavour, odour and texture. Unfortunately, fat degradation (or rancidity) is only conveniently measured on extracted oils. Therefore, it is necessary to extract the oil from the flesh first. In practice, this means that such tests can only be applied to those fish of high fat content.

The standard analyses of fat rancidity appear to be simple but, in practice, fat extraction and/or fat analysis may alter the composition to such an extent that the results are meaningless. Such methods are much more appropriate for assessing the quality of extracted oils obtained as commercial by-products.

The routine analyses are:

- (i) Free fatty acids content, which is a titration.**
- (ii) Peroxide value, which must be performed in subdued light, and is a titration.**
- (iii) Aldehyde detecting reactions, which are colorimetric.**

**(e) Salt and moisture content**

**The quality of products such as salted fish, sun dried fish and smoked fish is essentially determined by:**

- 1. The quality of the fish before processing.**
- 2. The adequacy of the processing.**
- 3. The adequacy of the storage.**

**The tests previously referred to may be applied to the fish before processing. If good quality fish are used and they are carefully processed and properly stored, then a good quality product will be obtained. The products are preserved primarily by reducing the water activity, i.e. by reducing the water content and/or increasing the salt content; analyses of these components serve as a check on the processing.**

**Moisture analysis:**

**Take an accurately weighed sample and cut into small pieces. Dry in an oven at 105°C for 3 hours. Break up the pieces, taking care not to lose any sample, and dry to constant weight. The weight loss is taken as the water content.**

**Salt analysis:**

**Take a small sample and homogenise in distilled water to thoroughly extract the salt. Centrifuge and dilute the supernatant to volume. Determine salt by titration with silver nitrate. The volume of silver nitrate used is proportional to the salt content.**

**Chloride meters are available but their performance may be erratic when used on protein-rich extracts.**

## **Physical methods**

### **(a) Measurements of flesh impedance and capacitance**

**The term impedance may, in practical terms, be considered as resistance to alternating current. (In fact that is an over-simplification and it is more accurate to refer to resistance and inductance.) The term capacitance may be considered as a measure of the ability to retain electrical charge.**

**Instruments capable of measuring either impedance, or impedance and capacitance, have been developed over the last 30 years. The most recent and most satisfactory instrument is known as the Torry Fish Freshness Meter (TFM). The TFM has four electrodes which are placed upon the fish. It is most important that a consistent position is used for all measurements. Two electrodes measure the impedance and capacitance; the other pair ensure good electrical contact and automatically correct the reading to the value which would be observed at 0°C. The reading is displayed digitally in the range 1 to 19; rarely does the value exceed 16 for UK fish, such high values corresponding to the highest quality fish.**

**The rate at which the TFM reading declines depends upon the species. It is known that changes in proteins and cell membranes caused by enzymes and microorganisms are responsible for the fall in the TFM reading as the fish deteriorate. Physical damage caused by rough handling and bruising also markedly reduces the TFM reading, probably to a greater extent than the physical damage reduces the eating quality, and many workers consider this a disadvantage. When applied to fatty fish, the TFM reading is also markedly influenced by the fat content (and thus the season) and, although the fat content may genuinely influence the eating quality, this fact is also looked upon as a disadvantage.**

**Since the properties of the flesh and skin are different, fish with the skin on show different results from fish that have had the skin removed.**

**Current cost of the TFM is in the region of £400. However, it is easy to use, robust, portable and ideally suited to field operations. The only routine maintenance is to recharge the batteries daily. So far, this instrument has been little used in the tropics but UK experience suggests it could be of some value.**

### **Summary**

**With reference to the hypothetical ideal quality assessment method mentioned at the beginning of this lecture, the chemical and physical methods most closely approaching the ideal are:**

- (i) the xanthine oxidase impregnated test paper;**
- (ii) the Torry Fish Freshness Meter;**
- (iii) a trimethylamine or total volatile nitrogen sensitive electrode system;**
- (iv) the Conway microdiffusion method for TVN.**

### **References**

#### **For Trimethylamine (TMA) Method**

- 1. CASTRO, L. A. B. (1975) Boletim do Instituto de Pesca, 4, (2), 29 - 36.**
- 2. CHANG, G. W., CHANG, W. L. and LEW, K. B. K. (1976) Journal of Food Science, 41, 723 - 724.**
- 3. MONTGOMERY, W. A., SIDHU, G. S. and VALE, G. L. (1970) Council for Scientific and Industrial Research Food Preservation Quarterly, 30 (2), 21 - 27.**

**4. RUITER, A. (1971) Voedingmiddelentechnologie, 2, 1 - 10.**

**5. VELANKAR, N. K. and GOVINDAN, T. K. (1960) Proceedings of the Indian Academy of Science, 52B, pp. 111 - 115.**

**For Total Volatile Nitrogen (TVN) Method**

**1. BURT, J. R. (1977) Process Biochemistry, 12 (1), 32 - 35.**

**2. CLIFFORD, M. N. and KUMAR, N. Grimsby College of Technology (Unpublished results).**

**3. ESHIRA, S. and UCHIYAMA, H. (1975) Bulletin of the Tokai Regional Fisheries Research Laboratory, No.75, p. 63.**

**4. JAHNS, F. D., HOWE, J. L., CODURI, J. R. and RAND, A. G. (1976) Food Technology (USA), 30 (7), 27 - 30.**

**For Physical (TFM) Method**

**CHEYNE, A. (1975) Fishing News International, 14, (12), 71 - 76.**

