

[Home](#)-immediately access 800+ free online publications. [Download](#) CD3WD (680 Megabytes) and distribute it to the 3rd World. CD3WD is a 3rd World Development private-sector initiative, mastered by Software Developer [Alex Weir](#) and hosted by [GNUveau Networks](#) (From globally distributed organizations, to supercomputers, to a small home server, if it's Linux, we know it.)

[home.cd3wd.ar.cn.de.en.es.fr.id.it.ph.po.ru.sw](#)

51033-BK

VITA TECHNICAL BULLETIN

HOME FLOUR MILL

by

WALTER B. BOOHER

This grain mill, except for the buhrs (which are stone), shaft, bolts, screws, and glue, is built of wood. Plywood is specified, but plain boards can be used. In 1976, at Miami, Florida, prices, the material for the mill cost US \$6-8.

The mill can be powered with a 1/4 Horse Power electric motor, wind power, or by hand. Although the machine shown here is intended for single family use, the designer feels the machine could be enlarged easily by increasing all dimensions. To make a mill having a 9" diameter metal buhr (rather than the 4 1/2" diameter one shown here) the mill body might double in size;

however, the drive shaft need be enlarged only from 3/4" to 1".

The designer of this grain mill, Walter B. Booher, has been a VITA Volunteer for 11 years. For some time Booher, who has been a machine shop tool designer and high school teacher, owned and operated a small factory. Now retired, Booher remains an active technical participant in VITA programs.

Please send testing results, comments, suggestions and requests for further information to:

VITA

1600 Wilson Boulevard, Suite 500
Arlington, Virginia 22209 USA
Tel: 703/276-1800 * Fax: 703/243-1865
Internet: pr-info@vita.org

ISBN 0-86619-112-7

VOLUNTEERS IN TECHNICAL ASSISTANCE

Some Notes Before Beginning

The buhrs shown are two flat stones. However, the machine has been built and used with buhrs made of fired clay and then sandblasted to roughen them. Initial results were good.

Stone buhrs must be sharpened about once a year.

Before beginning, please read the entire plan carefully. Pay particular attention to the arrangement of parts as shown in the assembly drawings.

Each part will be discussed in some detail. The numbers below correspond directly to the parts being discussed; in other words number 1 is a discussion of part 1.

GOOD LUCK!

THE MILL BODY

Parts (1) (2) (3) (4):

hfm0010.gif (600x600)

hfm001.gif (600x600)

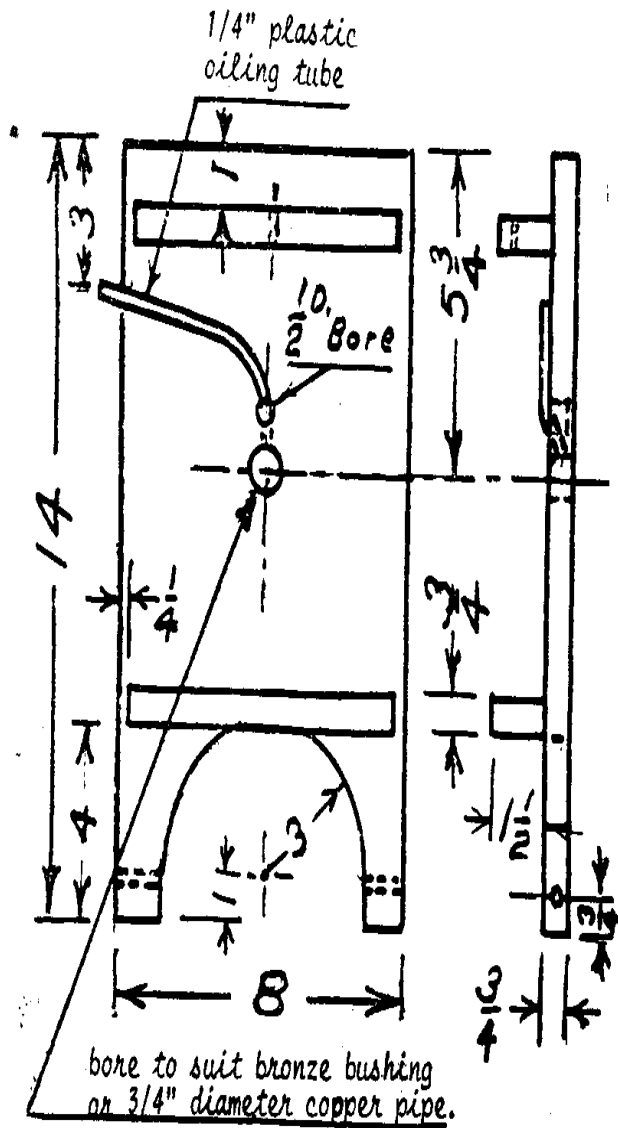

③ End Section.

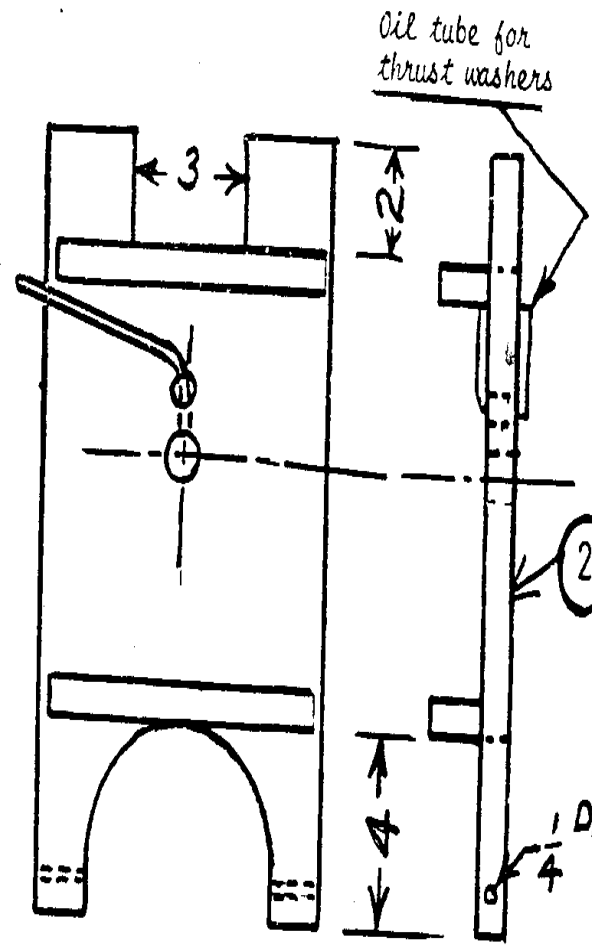

④ Center Bulkhead. Overall dimensions same as detail ③, note other variations.

accurate. Use epoxy glue in the four main joints. The use of 2" long finishing nails will avoid the necessity for using clamps. Be sure the mill body is perfectly square before setting it aside for the glue to harden overnight.

(1) Subassembly, Left Side.

(2) Subassembly, Right Side.

hfm002.gif (600x600)

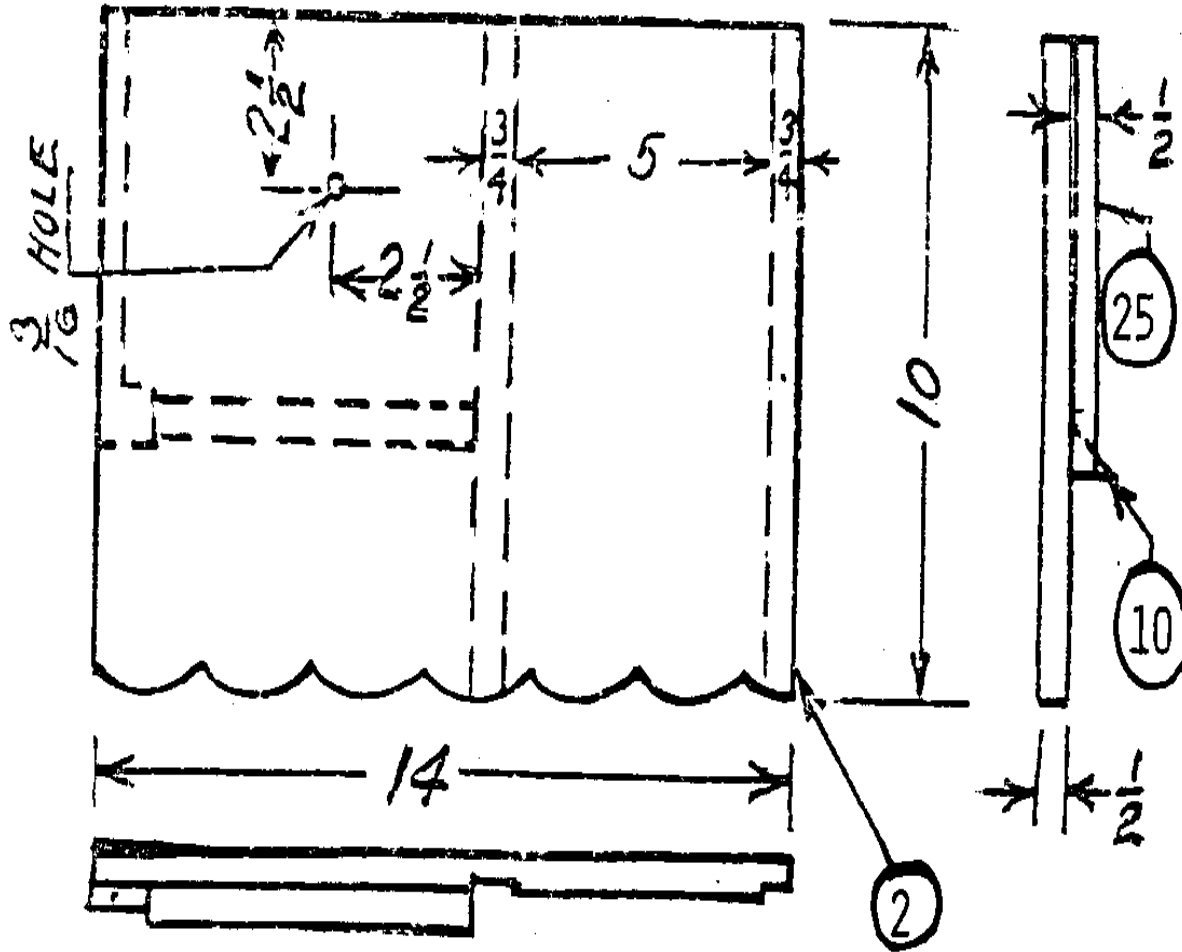

② Subassembly, Right Side.
For other dimensions see ①.

For other dimensions see (1).

(3) End Section.

hfm03.gif (600x600)

hfm04.gif (540x540)

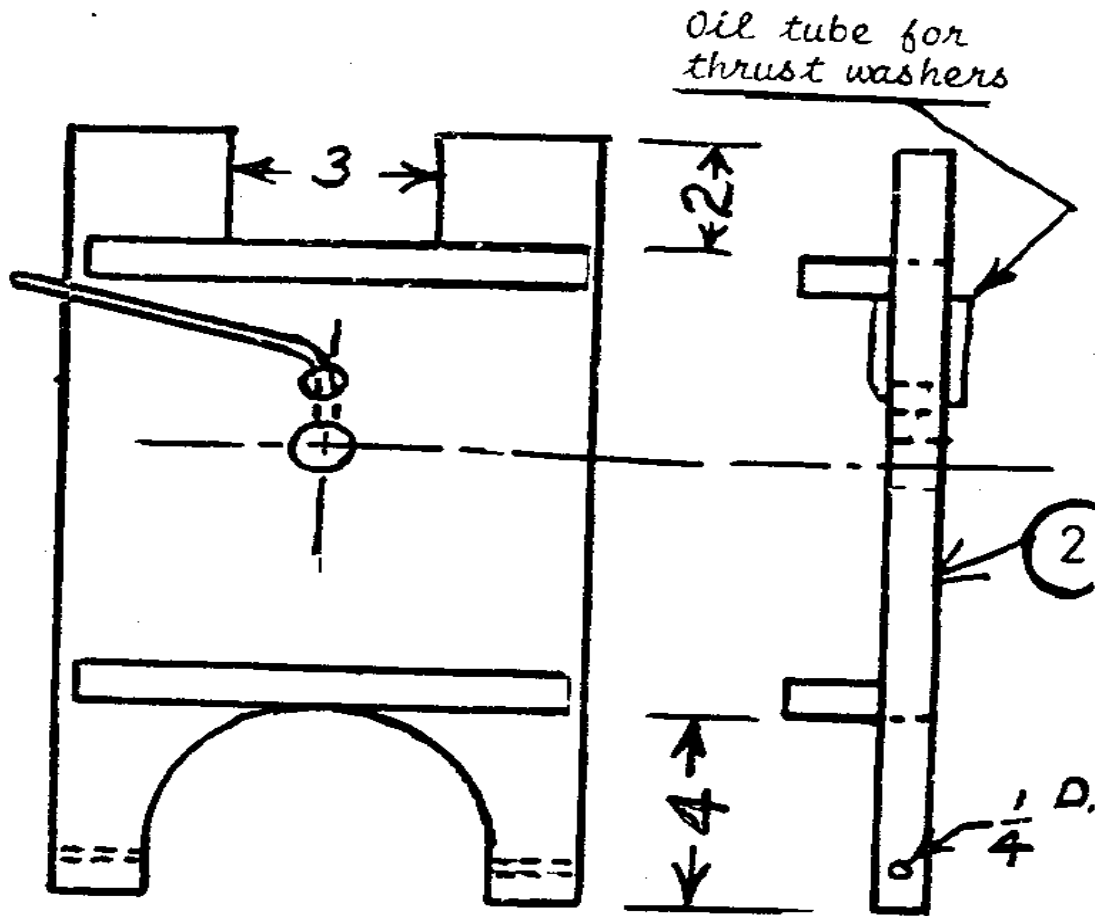

④ Center Bulkhead. Overall dimensions same as detail ③, note other variations.

dimensions same as detail (3), note other variations.

(5) Drive Shaft. Use 3/4 dia. cold rolled steel for this part. Use a 1/4 or

hfm005.gif (600x600)

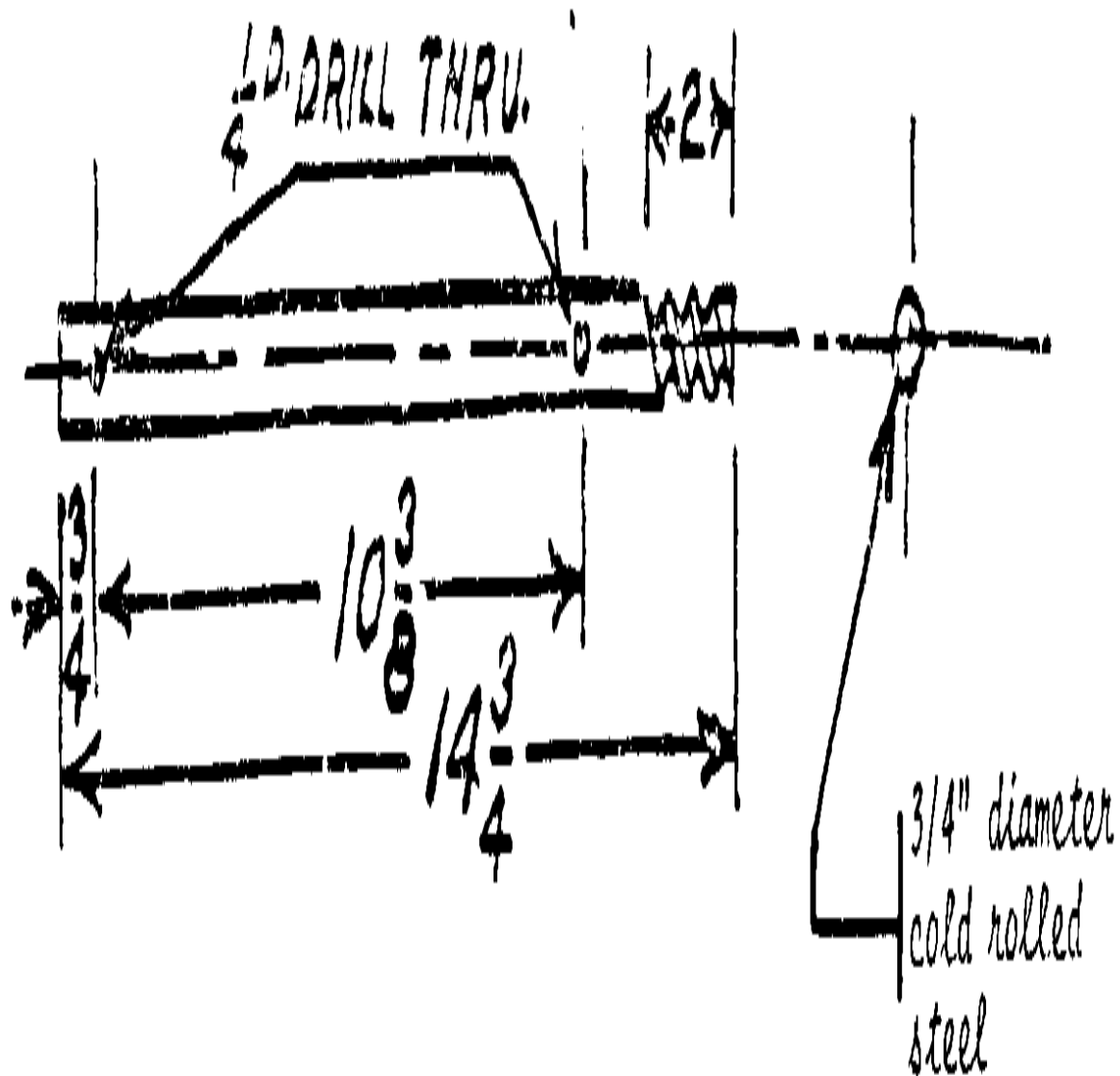

3/8 inch thickness grinding wheel or a 3/8 dia. round file to cut the spiral groove on one end. Cut the spiral groove about 5/32 of an inch deep. Follow drawing as closely as possible; however, some unevenness in the screw will not

prevent it from doing the job.

(6) Grain Hopper. Use plywood throughout.

hfm006.gif (600x600)

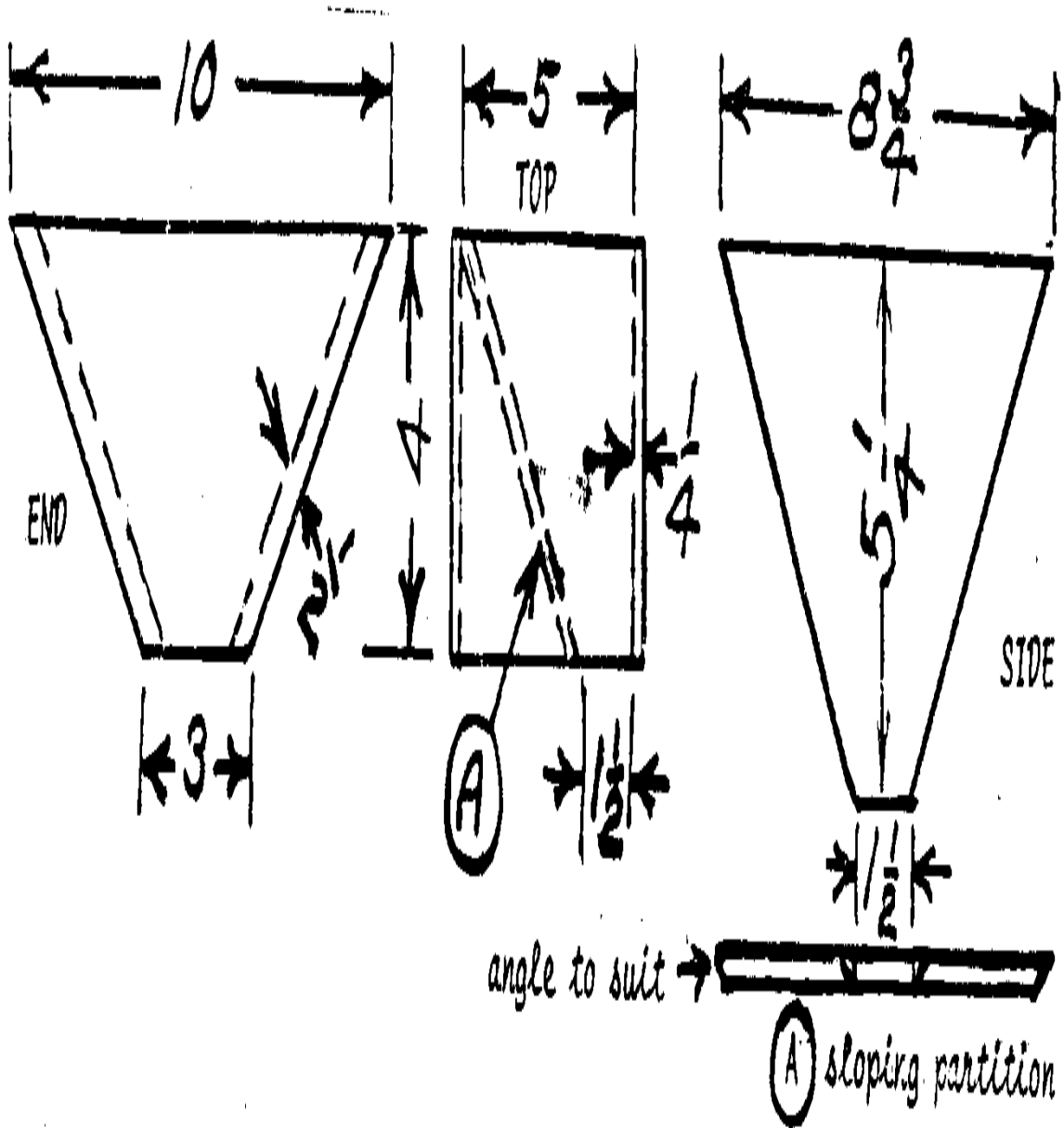

(7) Dribbler Trough Height Adjustment Bar. Use 3/4" thickness pine.

hfm007.gif (437x600)

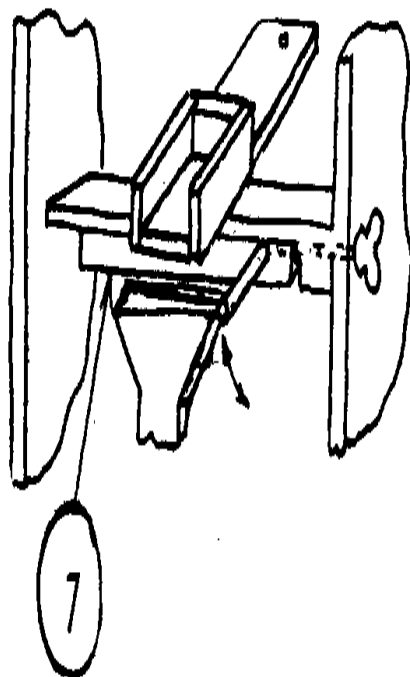
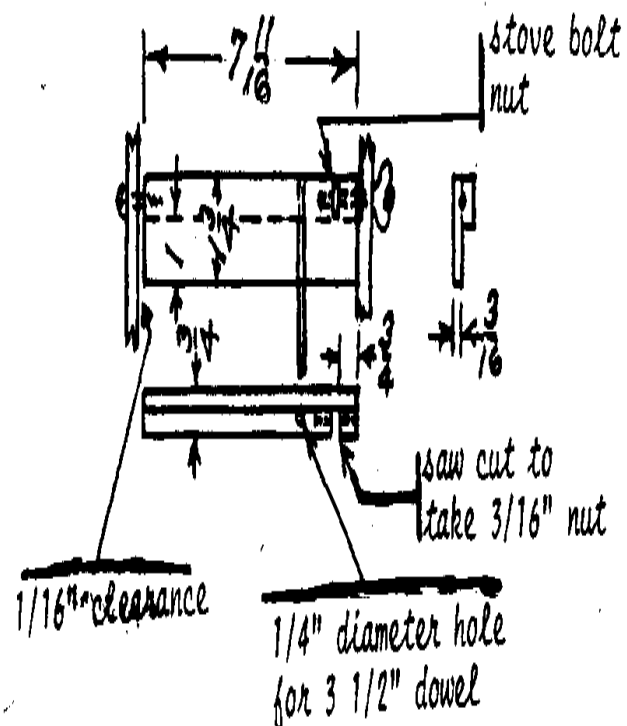

Stove bolt is 3/16" by 2". The winged nut is turned hard against the head of the bolt with epoxy against the head and in the threads. This makes a solid unit of the bolt and winged nut.

(8) Rocker cradle. This part including the

hfm08.gif (540x600)

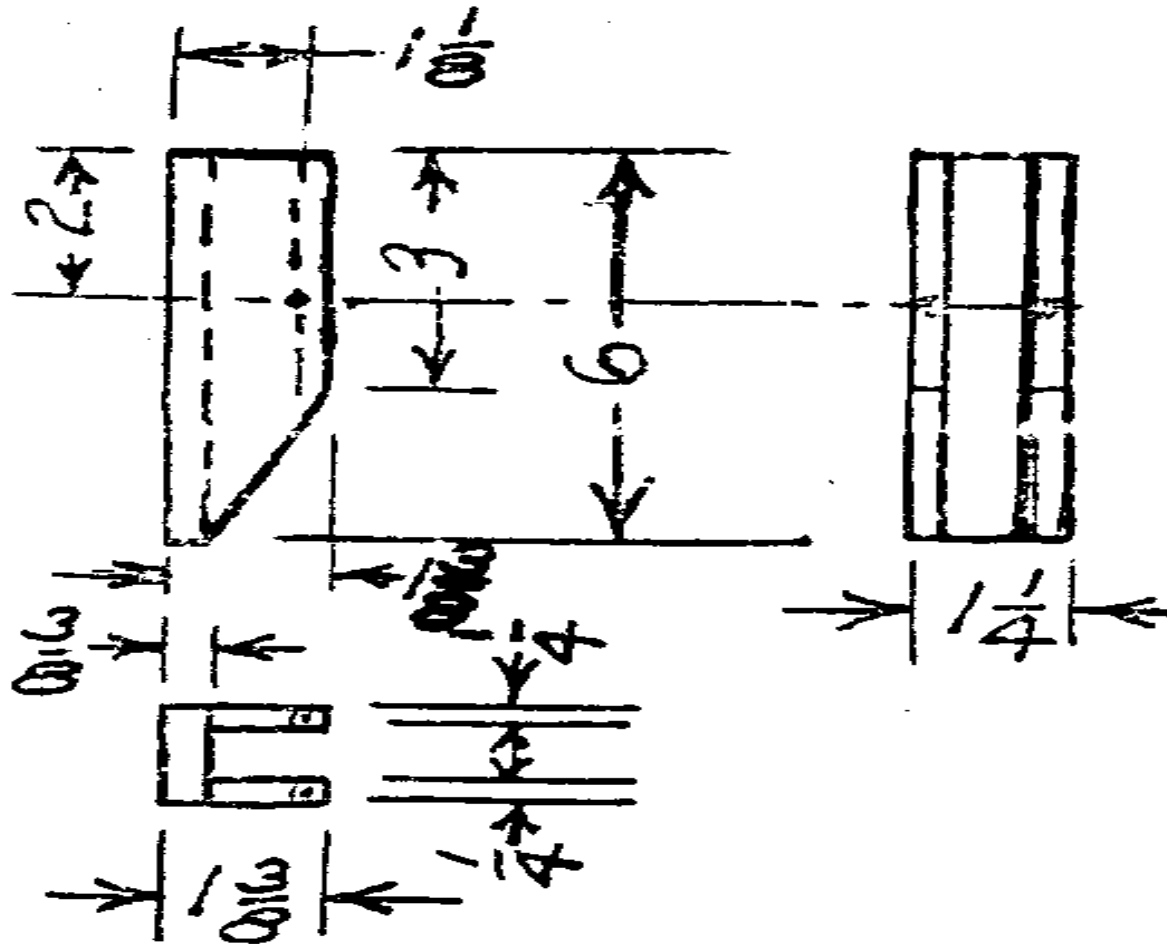

⑧ Rocker cradle
for dribbler
assembly

rocker bar, dribbler trough height adjustment bar and the revolving buhr holder are all shown digramatically in the sketch below. Notice that the eccentric action of the buhr holder provides the shaking action that

causes the grain to work slowly to the end of the dribbler trough where it falls into the funnel shaped part #19 that directs it

hfm019.gif (540x540)

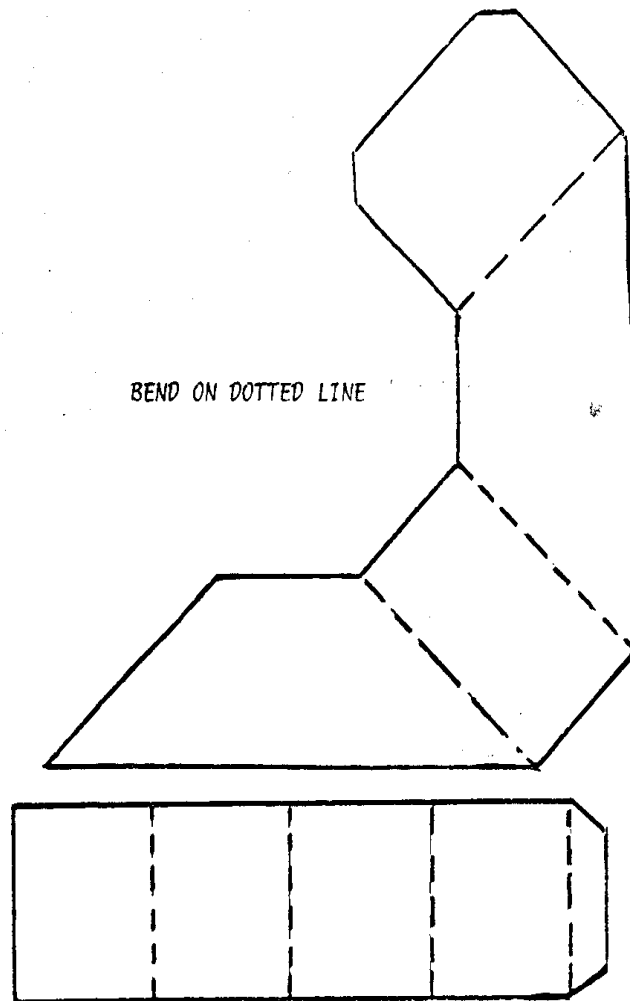
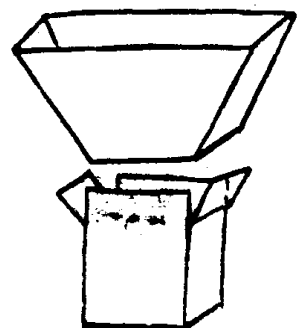

Patterns for detail (19). Use tinned metal for soldering.

into the buhrs.

(9) Rocker Bar.

hfm09.gif (540x540)

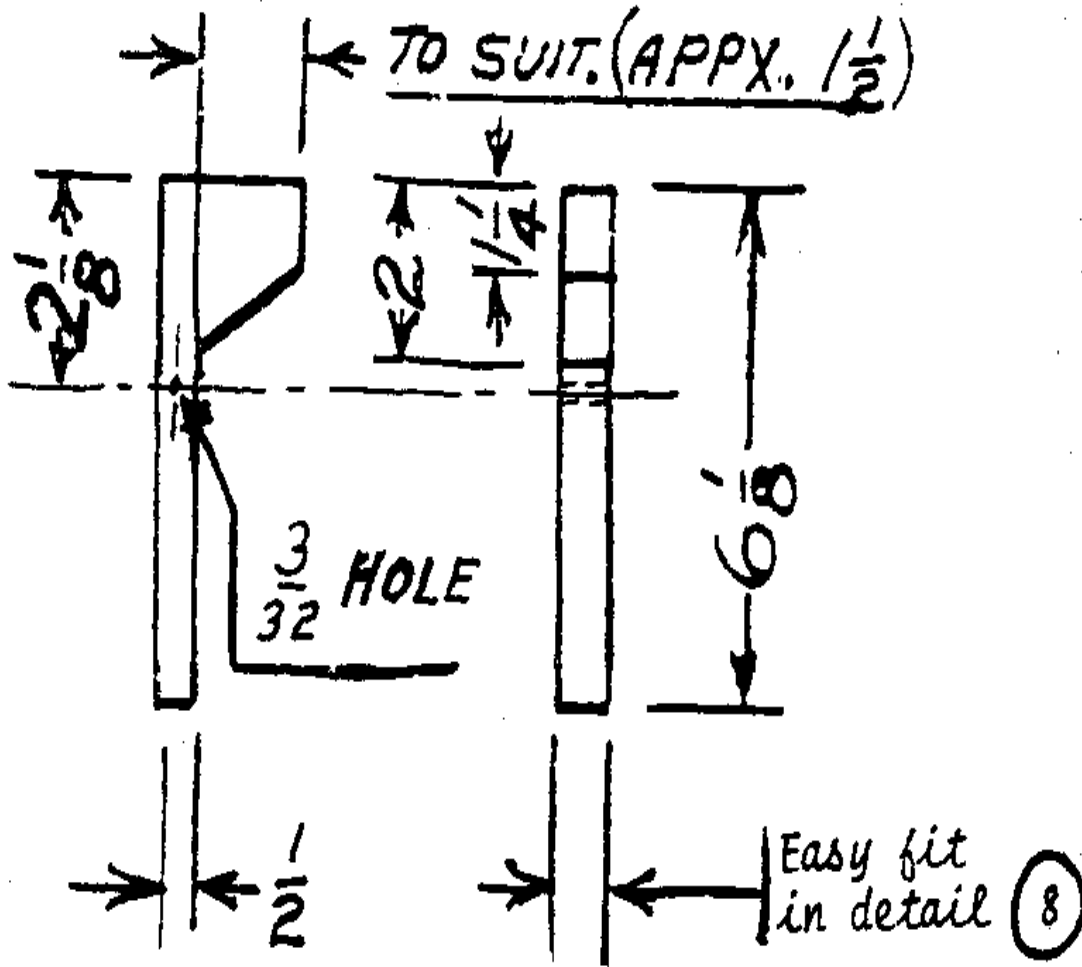

⑨ Rocker Bar.

(10) Shield the deflect meal. This

hfm009.gif (353x393)

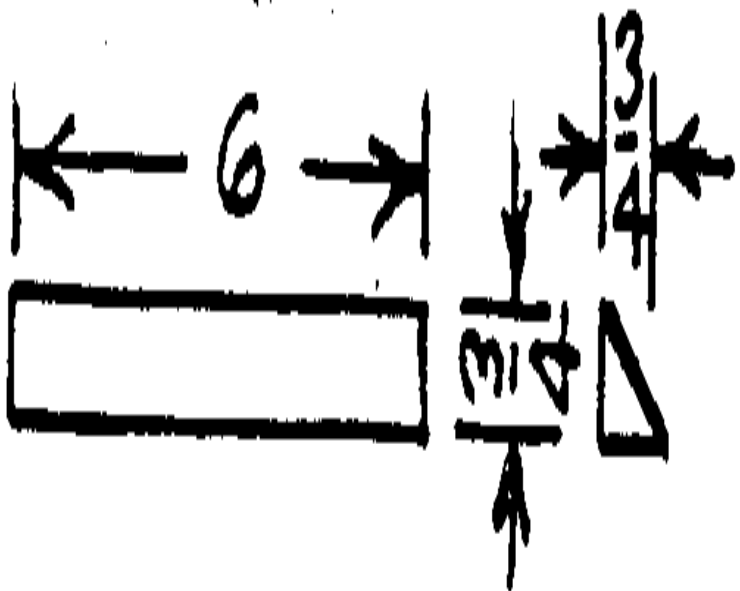

part helps to deflect the meal into the storage drawer. Two are required.

(S) This little spring holds the

hfm010.gif (600x600)

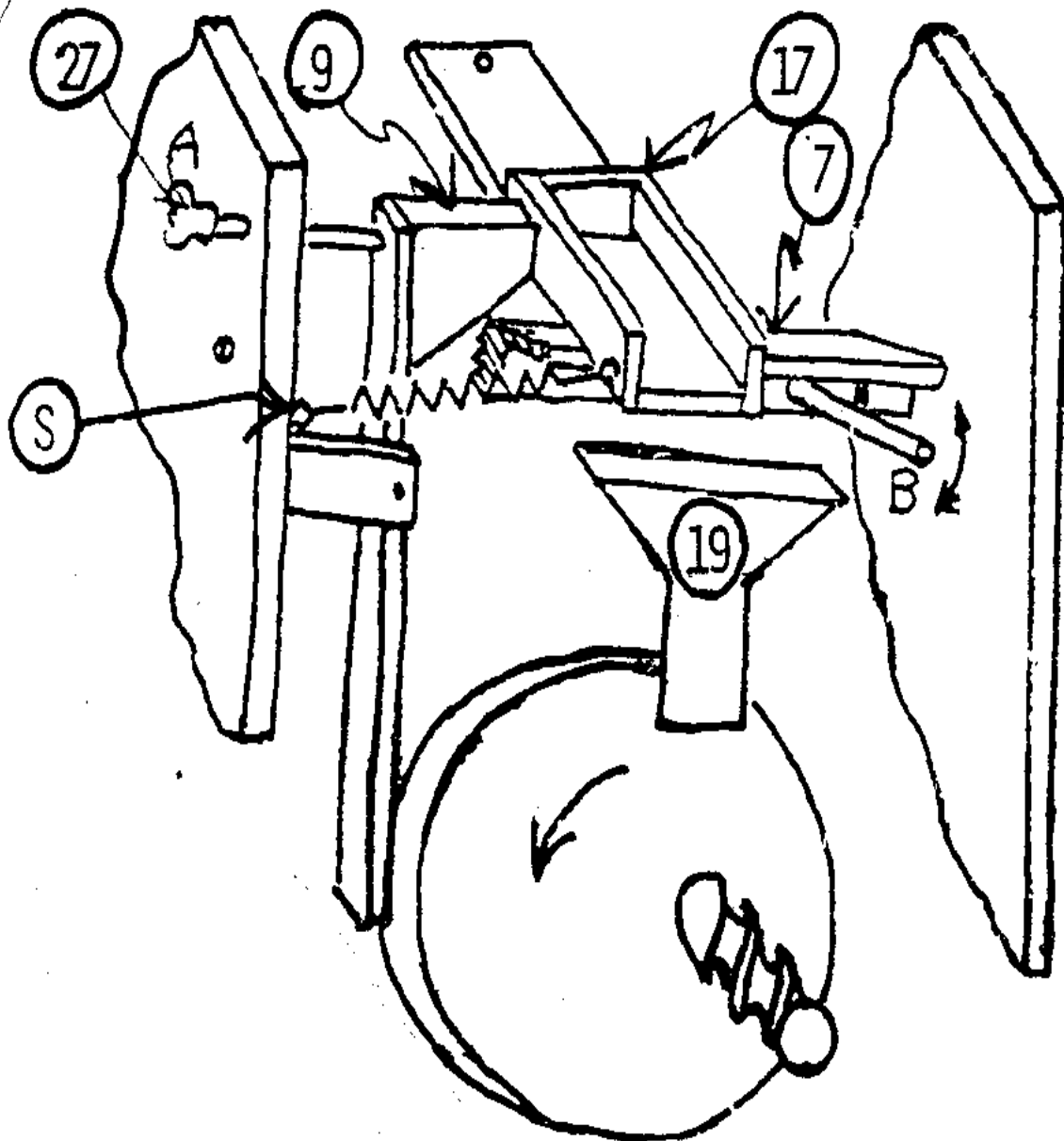

dribbler trough against the
Rocker Bar. It is attached at one
end to the dribbler as shown and the

other end is attached to the inside wall of the mill. The end attached to the mill wall should be about 1/2" lower than the end attached to the dribbler.

(11) The grain hopper base is attached to the left side of the mill body by

hfm011.gif (600x600)

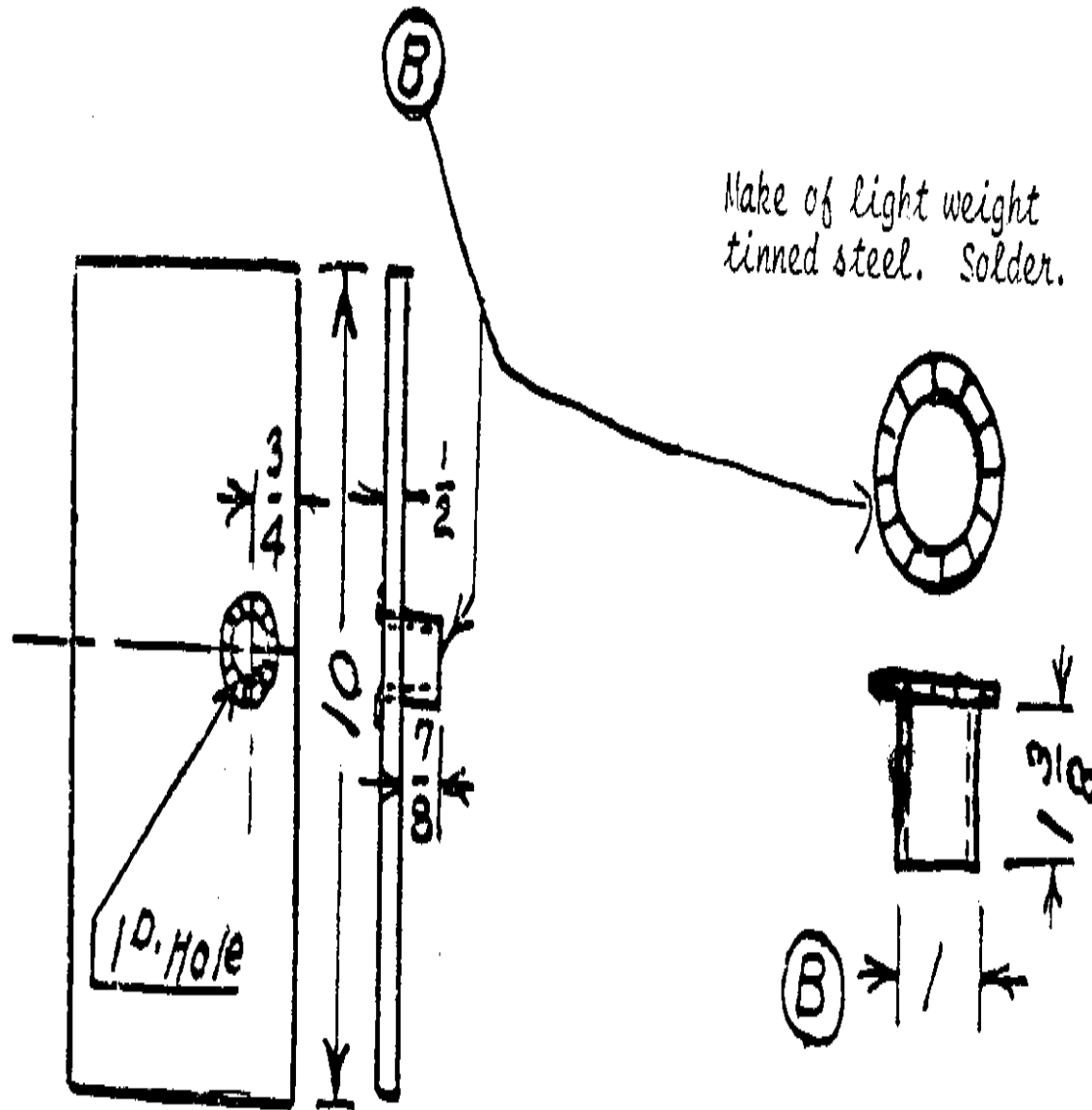

the use of two butt hinges. The hinges should have about a 1" long pin and 1" long leaf. The purpose of this manner of attaching the grain hopper is to make it possible to adjust the clearance between the grain hopper

spout and the dribbler trough. See parts 11 and 17.

hfm0110.gif (600x600)

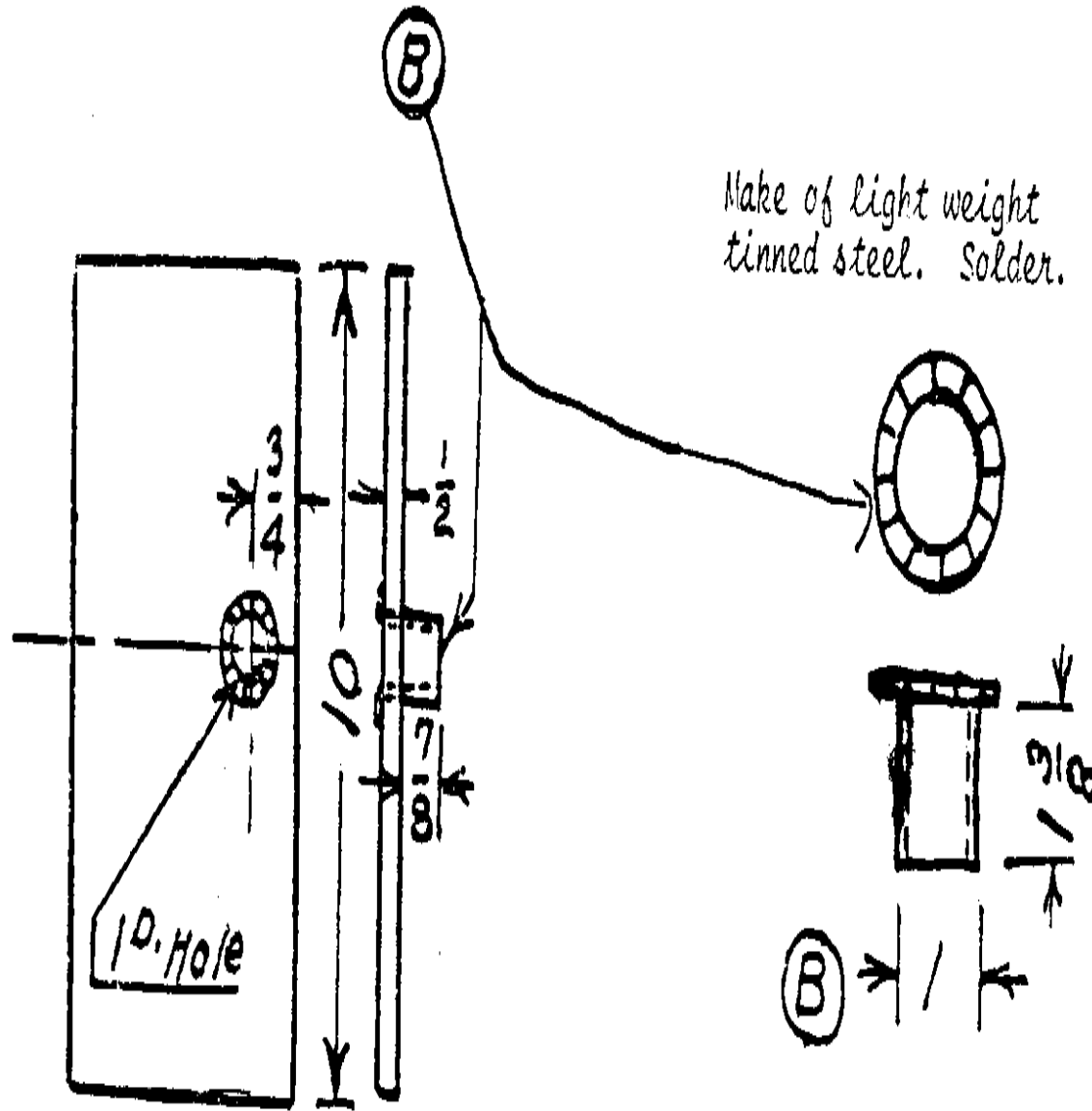

(12) Motor base is also attached to the

hfm012.gif (353x353)

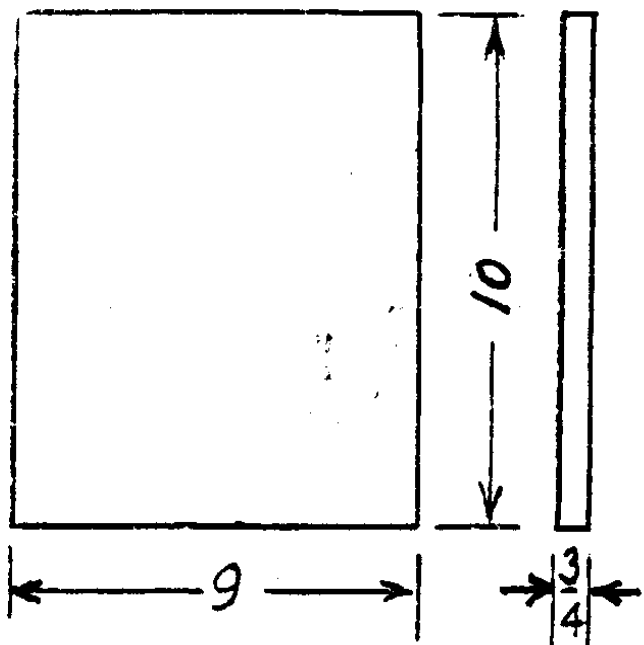

left side of mill body by two hinges
or same size.

(13) Buhr Adjustment Bar. Hardwood

hfm013.gif (486x486)

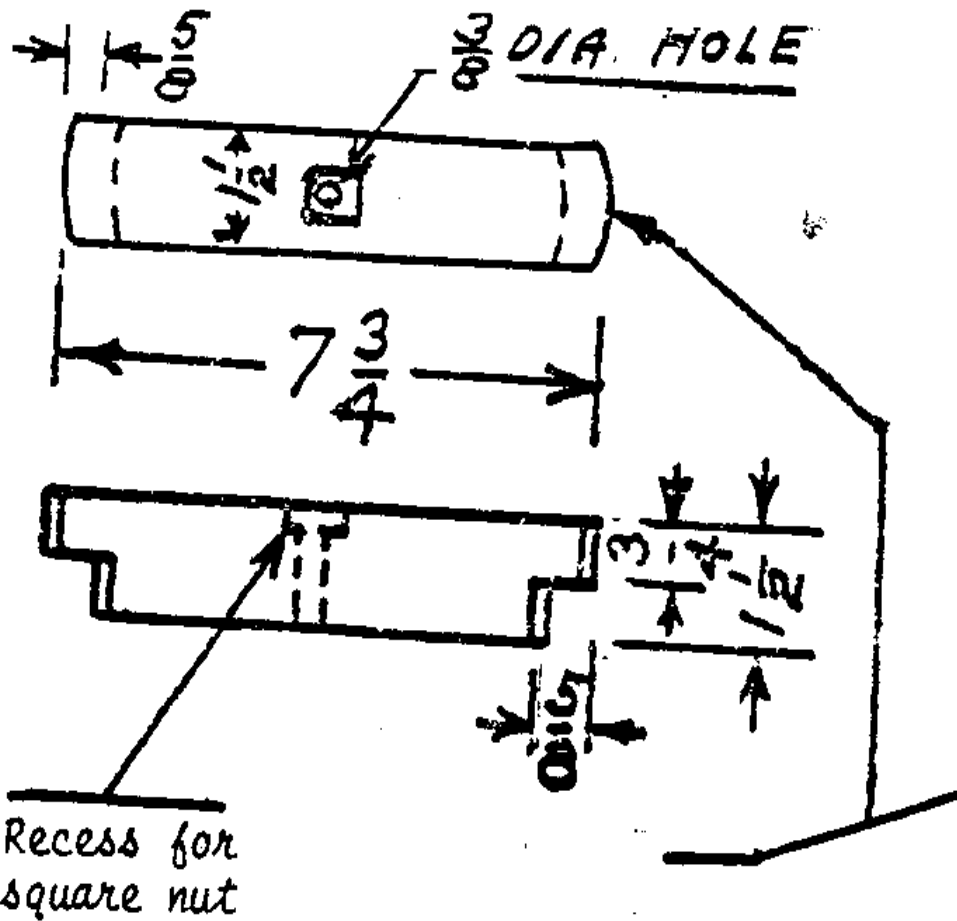

is preferred for this part.

(14) Rotating Buhr Holder.

hfm014.gif (600x600)

5/16 x 5/16"
slot for steel
pin. See detail 5

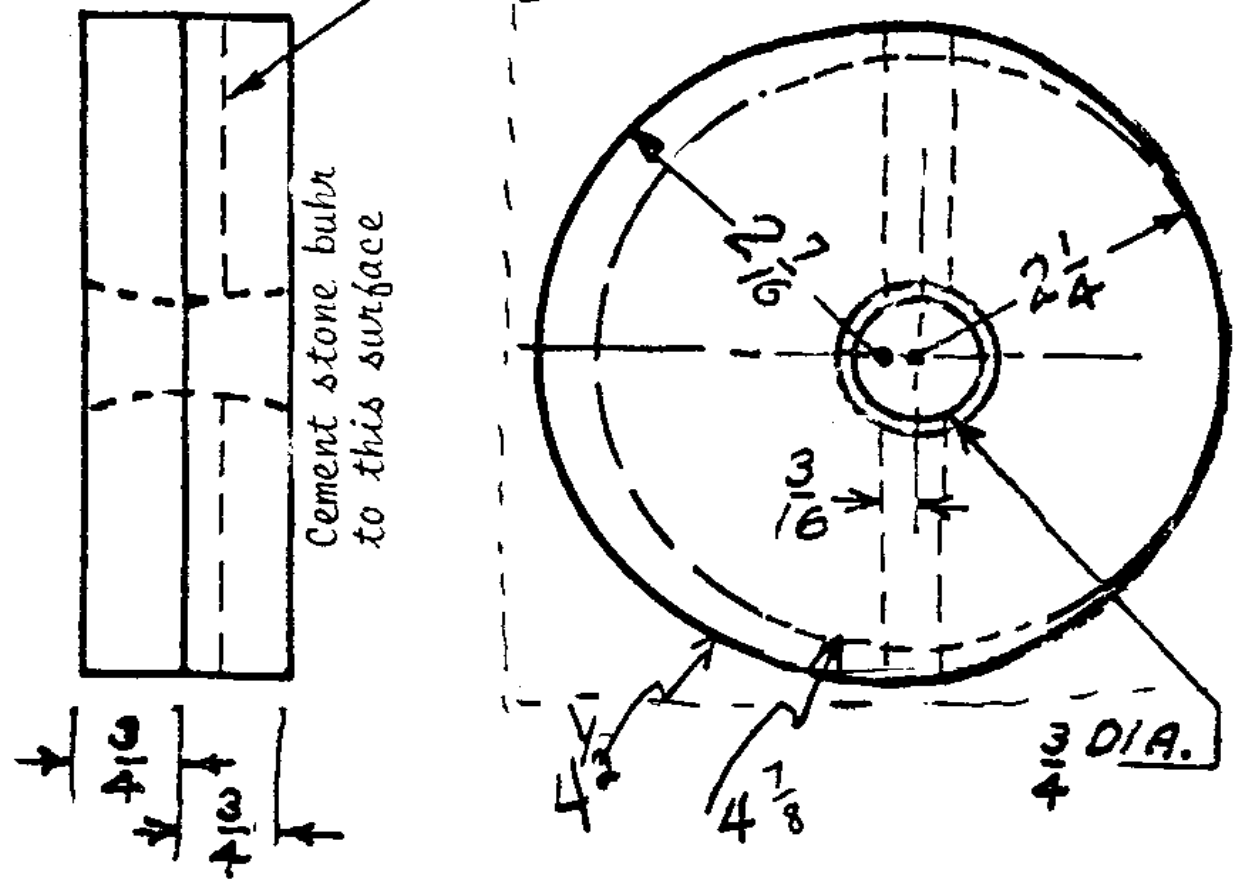

Use two pieces each 3/4" thickness plywood by 5" x 5". Before cutting the pieces round cut the 5/16" by 5/16"

slot in one of the pieces as shown. Fasten the two pieces together using about four screws and glue. The $3/4$ diameter hole should next be located. This hole should pass exactly thru the center of the $5/16 \times 5/16$ " slot. Before boring this hole, however, use a compass to scribe the $4 \frac{1}{2}$ " diameter circle. Then move the center of the compass $3/16$ " as shown and scribe a circle of $4 \frac{7}{8}$ " diameter. Now bore the $3/4$ " diameter hole. Saw out the circle on the outer line. Complete the part by using a round file to make the hole about $1/8$ " larger in diameter at both ends but let it remain $3/4$ " diameter at its center. The eccentric action of this buhr holder provides the action that shakes the dribbler trough.

(15) Stationary Buhr Holder.

hfm0150.gif (486x486)

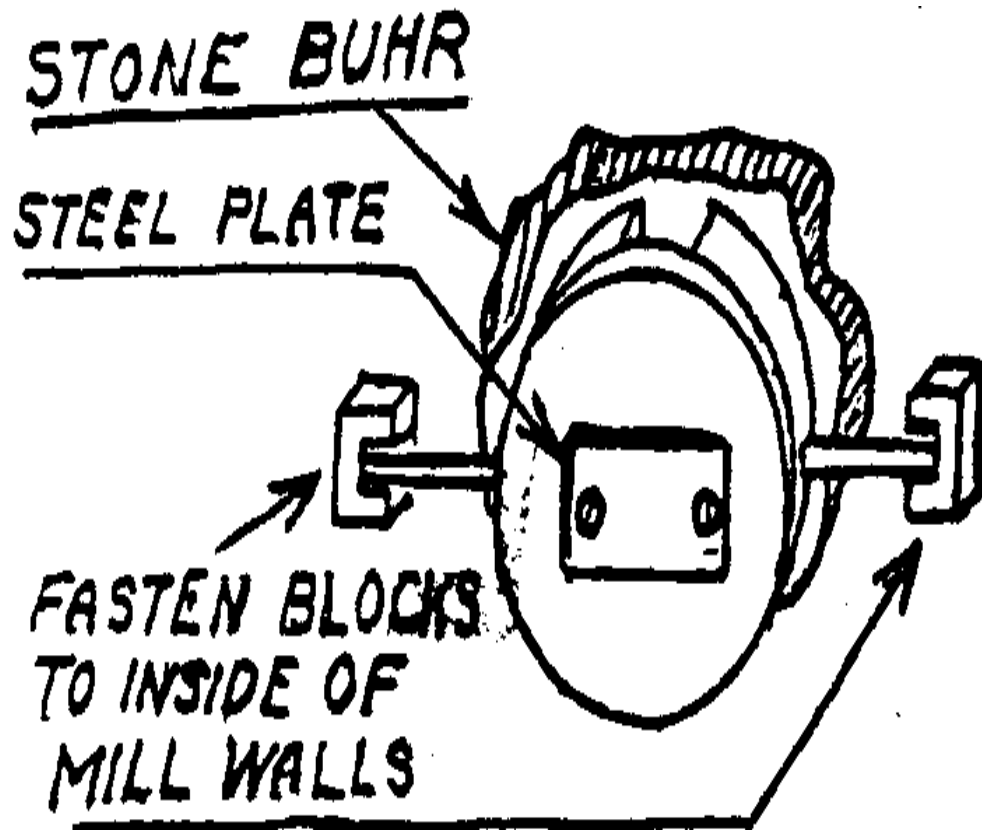

Use one piece of 1" thickness plywood and one piece of 1/2" thickness. First, saw out the two 4 1/2" diameter pieces. Then lay out on the 1" thickness piece, the 1" wide section that is to be cut out to receive part #19. Cut out for this piece with the grain of the wood. See assembly drawing. Next bore 3/4"

hfm003.gif (600x600)

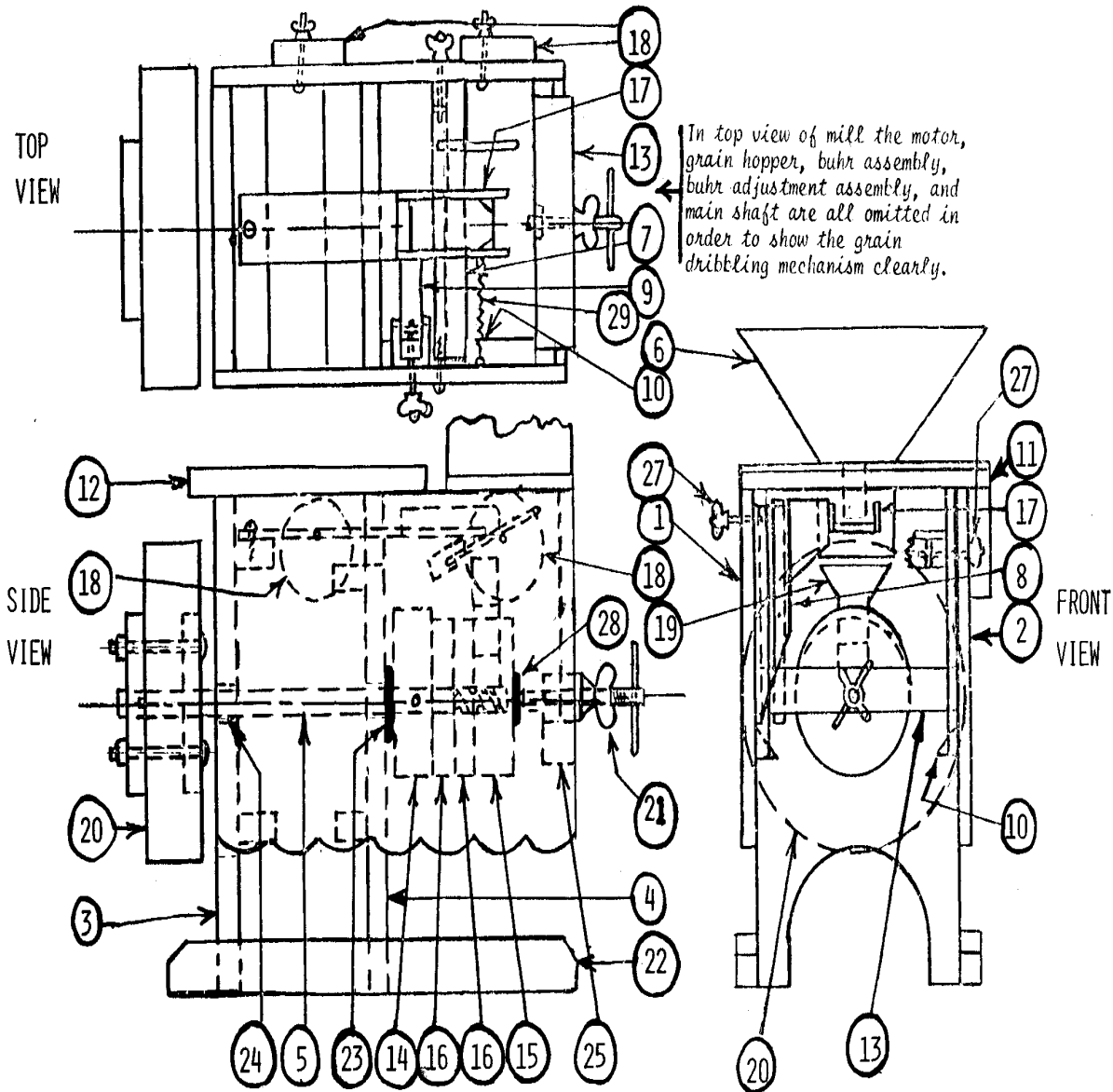

diameter hole in 1/2" thickness piece and

attach the small steel plate. (See detail #28.) Note also the sketch below showing the two 1/4" dowel pins, one in either side of this buhr.
holder.
Shown also
are two
parts not
shown in
drawings. These
two dowels and the
blocks into which they slide hold the
stationary buhr in place and prevent it from
turning. By loosening the buhr adjustment screw
(part #21) and removing part #13, the entire

hfm021.gif (230x600)

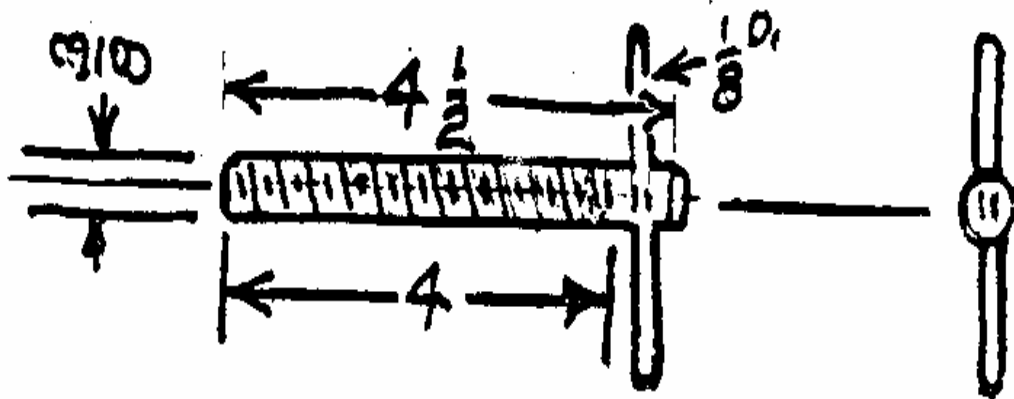

hfm013.gif (437x486)

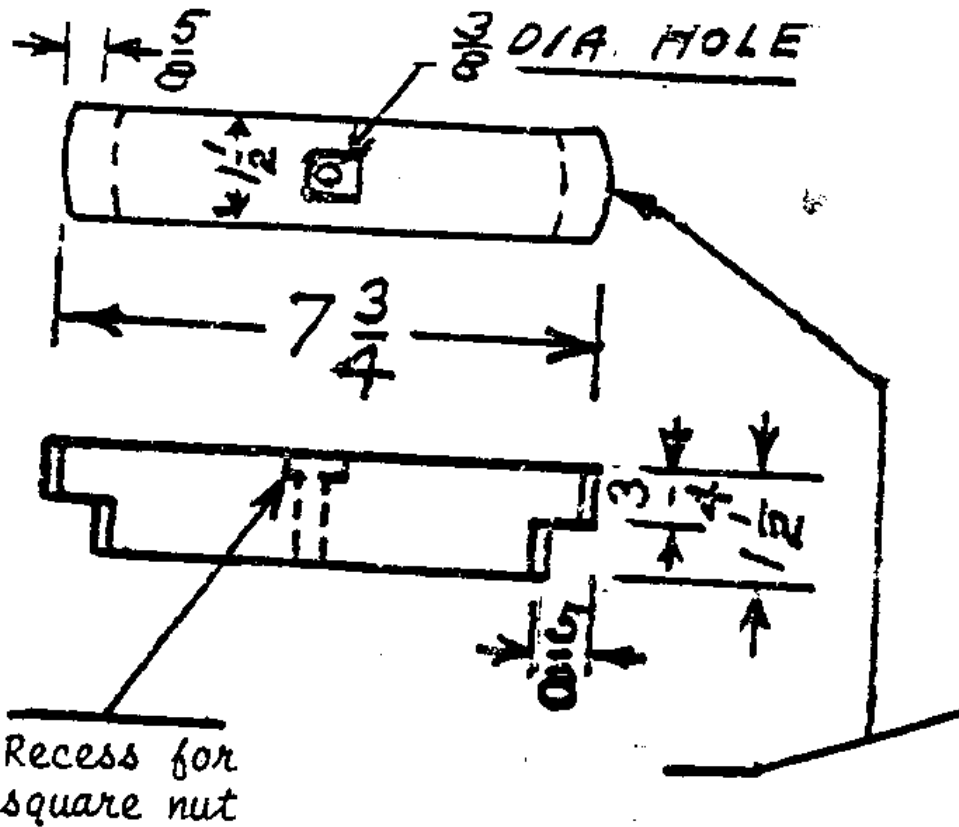

stationary buhr is removed.

(16) The stone buhrs. Make them from suitable stone that can be found along

hfm0160.gif (600x600)

STEP #1

After smoothing and mounting the buhrs, use chisel to form a $\frac{3}{16}$ " deep basin which is $2\frac{3}{4}$ " diameter.

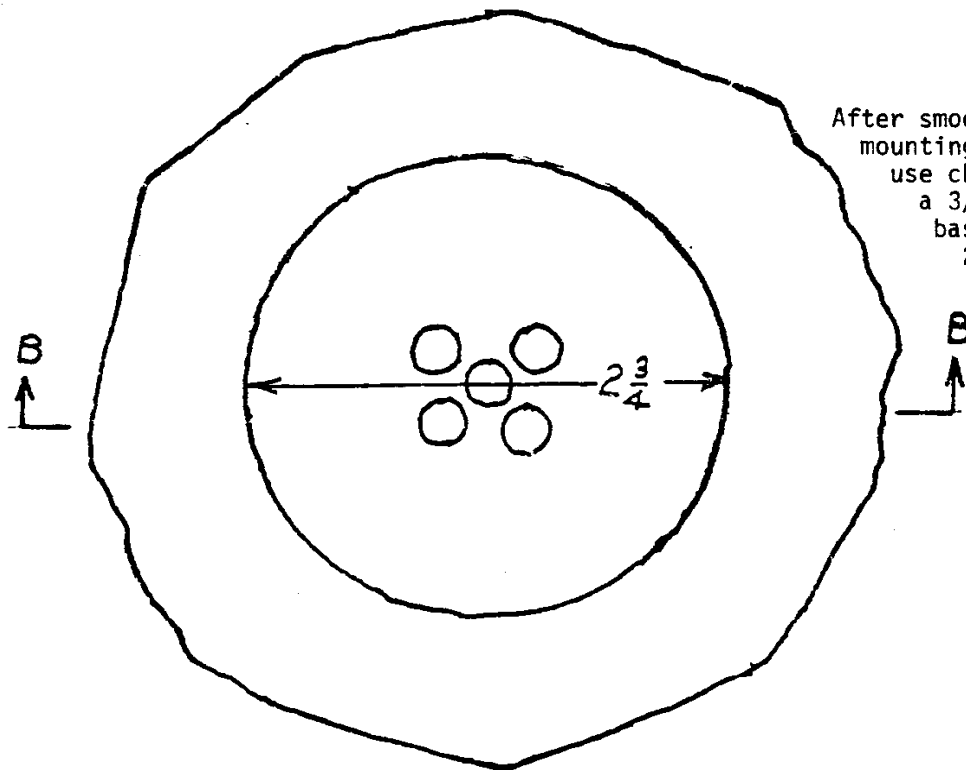

Make 2 identical buhrs. The outer edge does not have to be perfectly round but edges should be trimmed sufficiently so they are balanced when running.

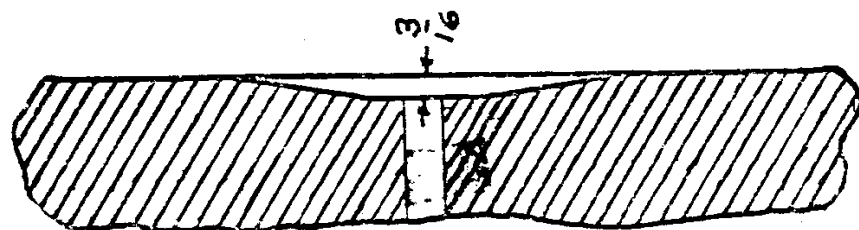

FULL SIZE

lake shores, river banks and in open fields. Sandstone and shale are too soft; some granite is too hard to work. As a test, you should be able to drill a hole readily with a masonry bit. Many kinds of stone, including

most limestone, are suitable for buhrs. It will pay to spend considerable time hunting for just the right two stones that will not require too much labor to complete. The stones should be between 3/4" and 1 1/8" thickness, have one flat side and be large enough to scribe a 4 1/2" diameter circle on them. Of course, you probably won't find stones with perfectly flat sides, and it will help to work a side flat by rubbing it hard over well hardened cement walks or slabs. Some hard sand sprinkled on the slab will make the cutting easier. It is safer not to use a hammer and cold chisel on the stone until it is firmly mounted on its buhr holder.

When mounting the stones on the buhr holders, be sure to have the flat surface of each buhr in a parallel plane with the flat surface of its buhr holder. If the surface being mounted against the buhr holder is irregular, hollow out some areas of the mounting block to conform with the irregular areas of the stone. Use epoxy to cement the stones to their mounting blocks. Use epoxy freely. After it has set overnight, fill in any visible openings around the edges of the stone and mounting block. It is well to have the center hole drilled in each but all chisel work should be done after mounting. In working stone by hand some variations are inevitable but if you hold a close approximation to the plan shown in detail #16 your stone should grind high grade flour.

(17) Grain Dribbler should be just

hfm11.gif (437x437)

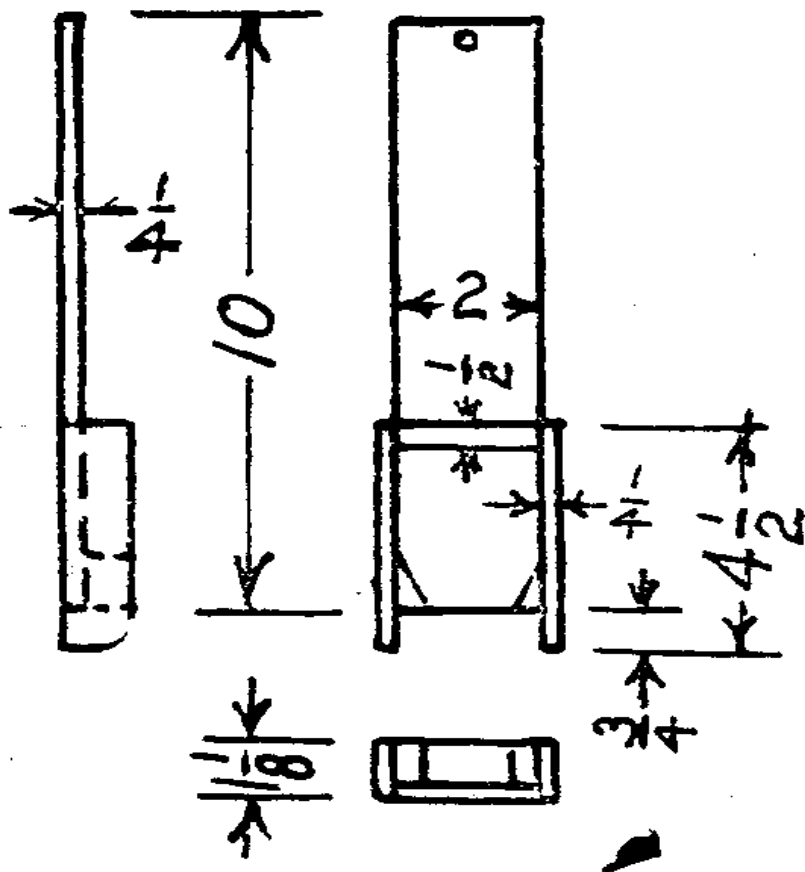

long enough to dribble grain
into part 19. In assembling the

hfm019.gif (486x486)

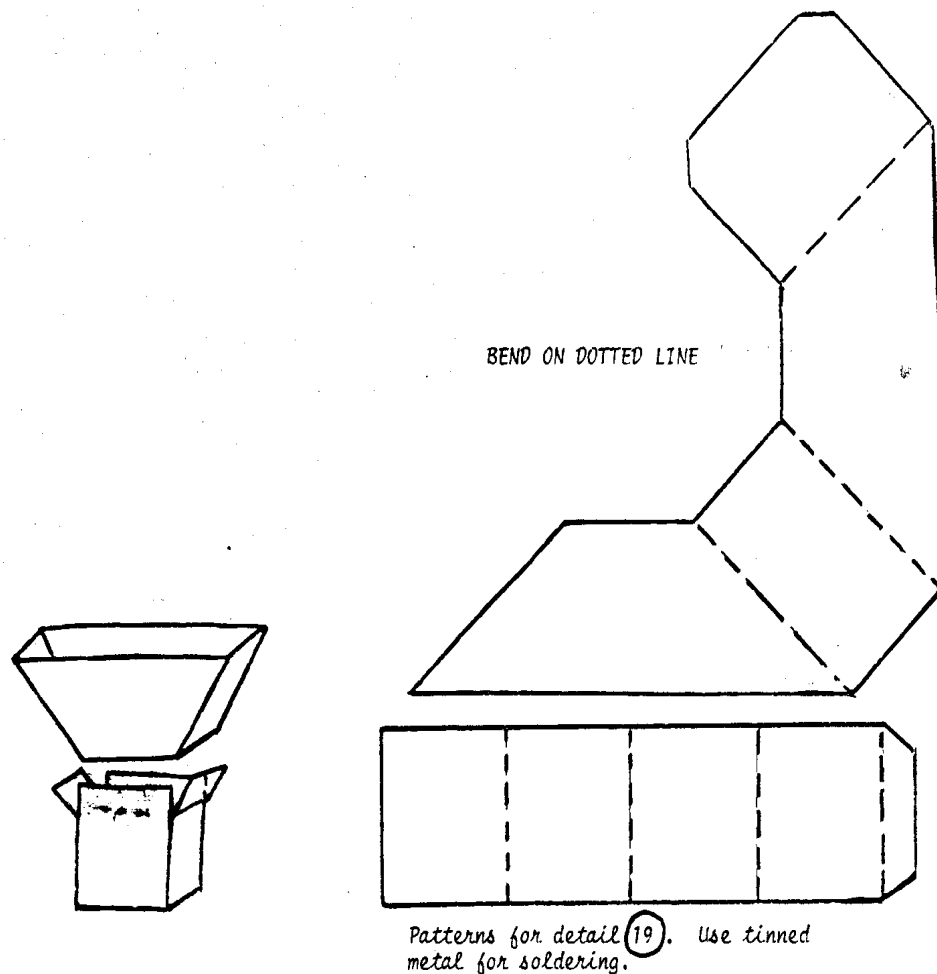

mill reduce the 10" dimension to suit.

(18) Eccentrics - Make 2. These two parts

hfm018.gif (256x437)

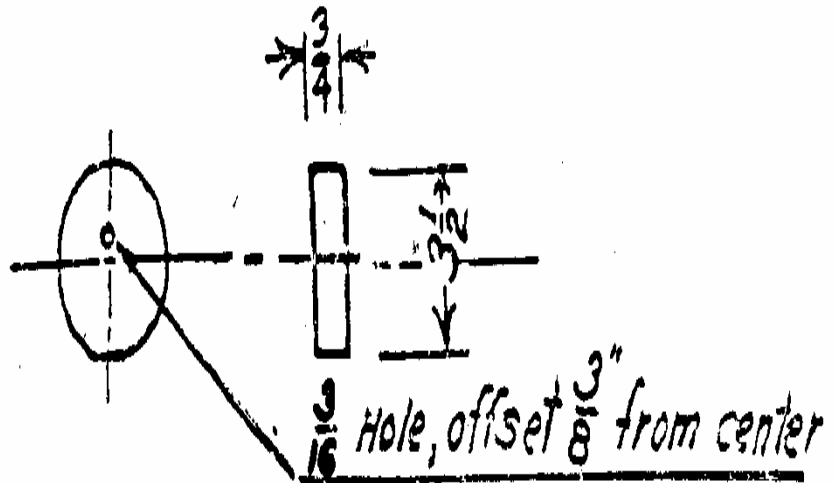

should be identical. Use epoxy under and around the head of the $\frac{3}{16}$ " bolt (inside mill body) on which these eccentrics turn. The one eccentric serves as a belt tightener and the other raises or lowers the grain hopper. Use winged nuts for convenience.

(19) Use light gauge tinned sheet metal to make this

hfm019.gif (486x486)

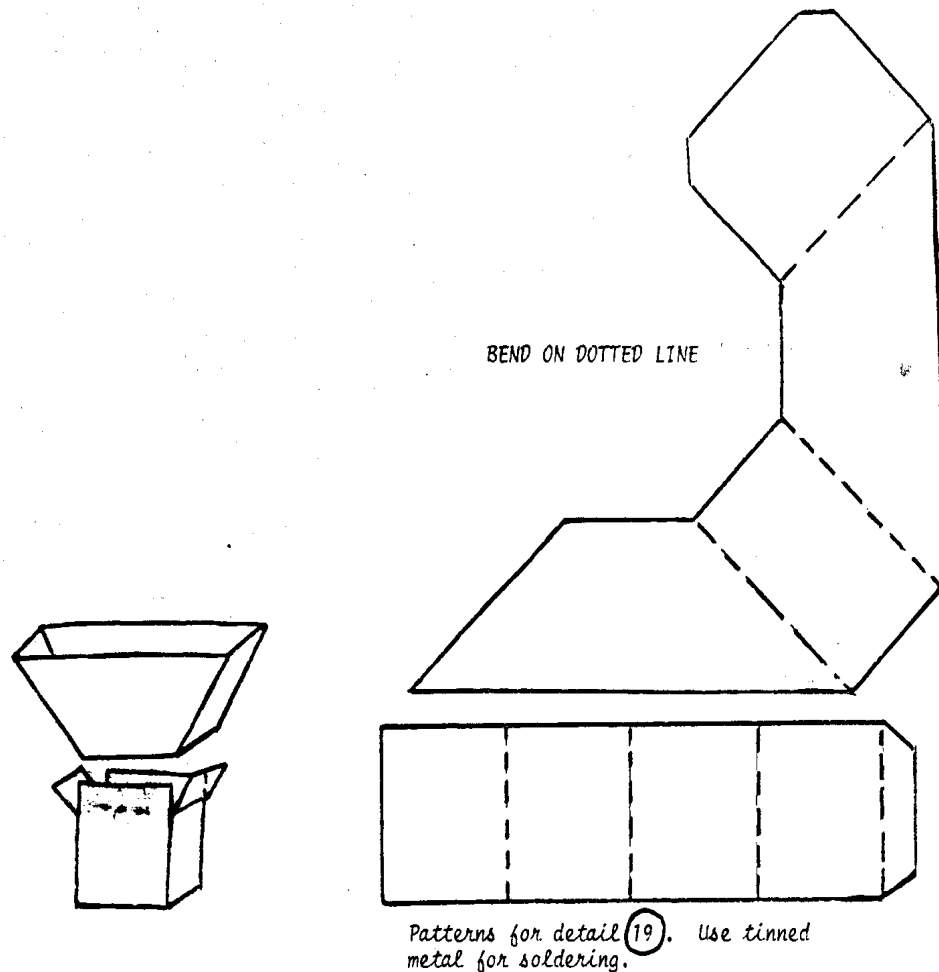

part. The auxiliary sketch shown here will help you. Use tin shears to make $1/4$ " cuts in each of the four corners of the square tube. Solder the seam of this tube then solder the seam of the rectangular funnel shaped section. Then, with two of the upper edges of the tube bent to

conform with the funnel-shaped section, place the two parts together and solder.

(20) The balance wheel is made of cement (concrete). Use one part portland

hfm0200.gif (353x540)

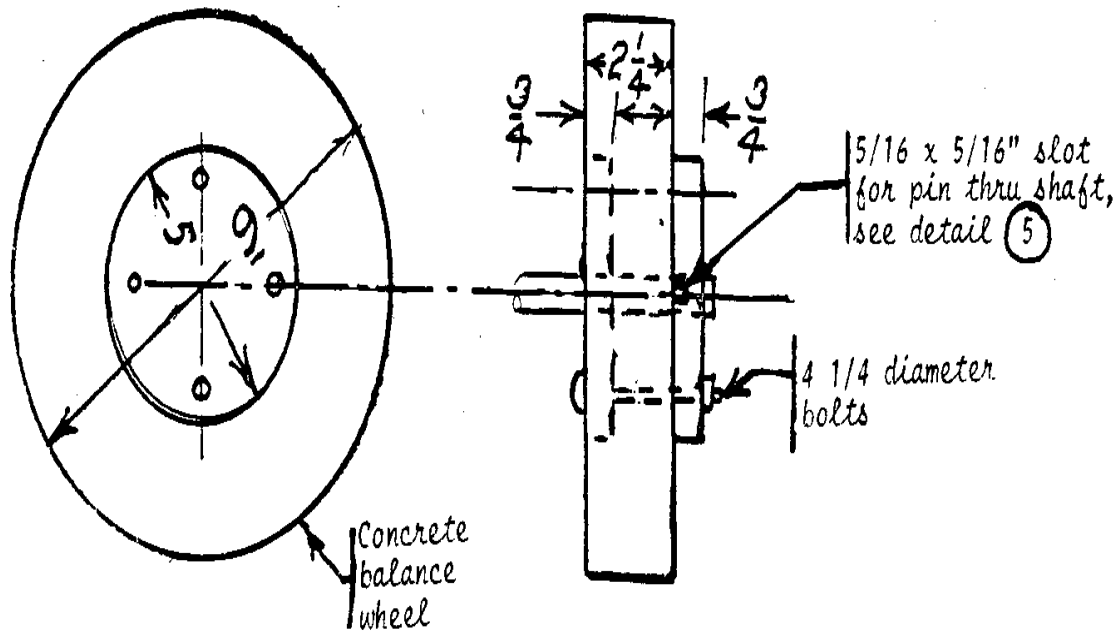

cement to two parts sand. You can make the form for it by sawing out a circle from 3/4" thickness plywood. The diameter of the circle should be 9" and the hole in center 3/4" diameter. Have a second 3/4" thickness block so the hole will have a depth of 1 1/2". When the 3/4" diameter shaft is placed in the form, this hole must hold the shaft exactly vertical

with the 9" diameter circle (see sketch). Saw out the two 5" diameter circles and bore for bolts. (If you plan to turn the mill with a crank, make these circles 7" diameter. These bolts are 3 1/2" long. Or make these bolts 5" long if you plan to attach a windwheel to this balance wheel.) The form for the wheel is made of light gauge sheet steel. (Cardboard can also be used.) Make 3" wide by 30" long. Bend around the 9" disc and tack or nail.

Assemble and pour the concrete. Let concrete harden for about four days. The sketch shows the form set up ready for the concrete. A section of the form is shown cut away for clarity of the drawing. The form including the shaft should be well coated with heavy grease so cement will not stick to form. Use a straight edge to strike off the cement after pouring. Avoid disturbing bolts. Note 5/16" x 5/16" slot thru the upper disc to take the 1/4" pin thru shaft when assembled. Wait until concrete has hardened four days before putting the upper disc in place.

(21) Buhr Adjustment Screw. Use in conjunction with a square nut and a winged nut.

hfm021.gif (167x600)

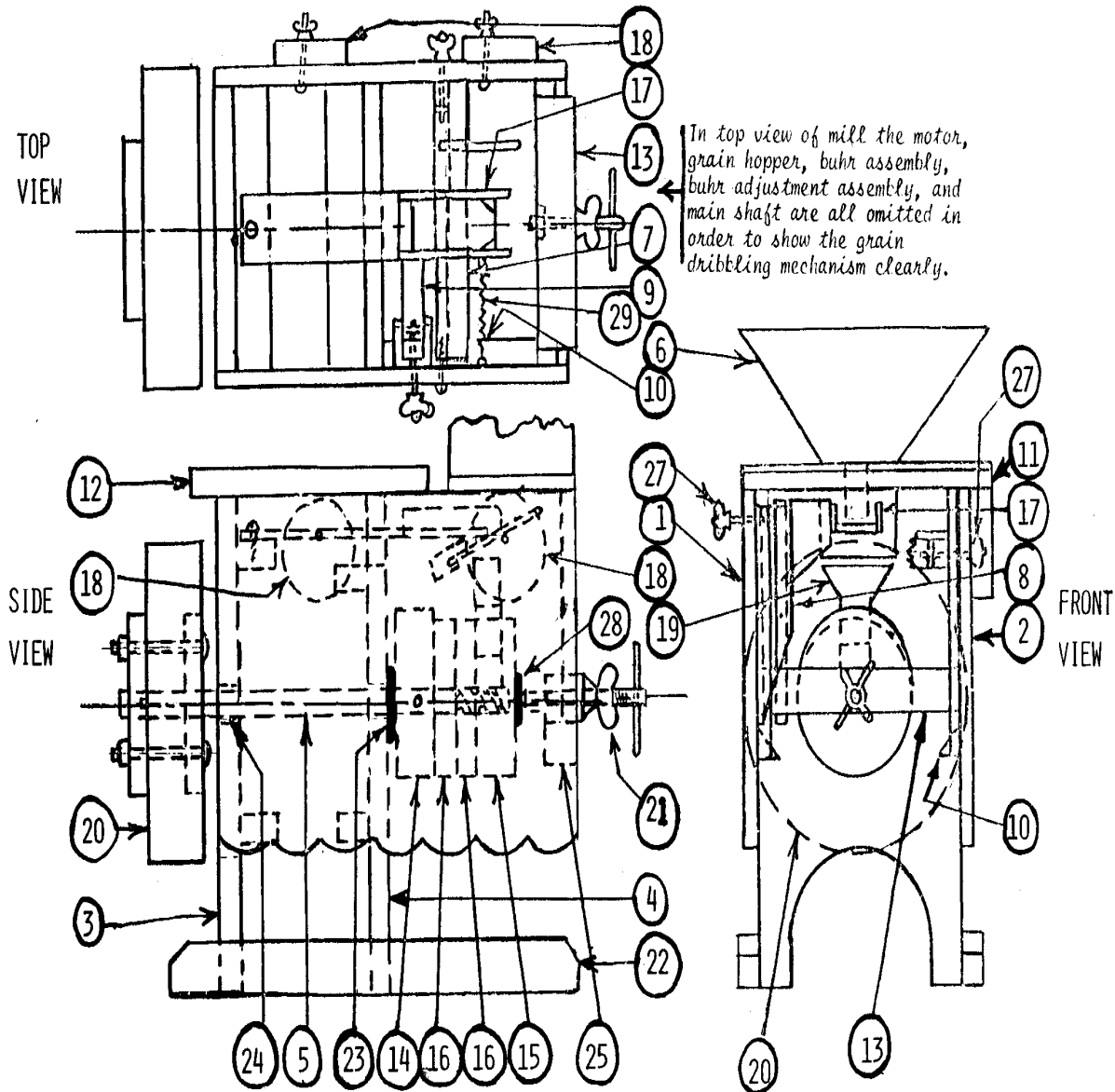

ASSEMBLY DRAWING OF MILL

Use 3/4" thickness pine lumber. Make the foot 1 1/2" high and 15 1/2" long. Bore 1/4" to suit matching holes in details #1 and #2.

(23) Use two steel washers with one copper washer between.

(24) Bronze Bearing. This can be a standard bronze sleeve bearing acquired at a bearing supply store, or it can be simply a short length of copper water pipe. If the light gauge pipe is used, it will be advisable to use a hacksaw to cut the piece lengthwise and remove about 1/8". Then compress it to fit the shaft more snugly. Before installing, roughen the outer surface to hold the epoxy better. The bearings should be put in place only after the body of the mill is permanently assembled and epoxy is hard. Put the bearings in place using epoxy. Then slip the shaft thru before epoxy hardens. With this precaution, the bearings will be held in alignment.

Still another way to provide the bearing is to make a bearing entirely of epoxy. Bore a 1" diameter hole for the shaft, make a collar to hold the shaft exactly in the center of the hole in parts (3) and (4) then with the shaft

hfm001.gif (600x600)

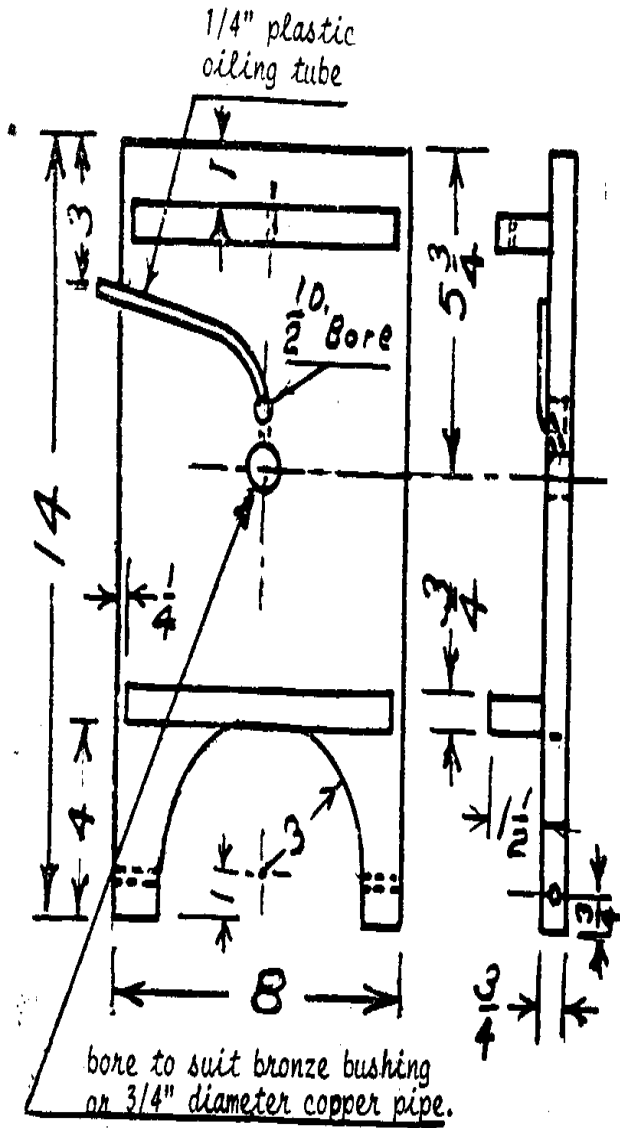

③ End Section.

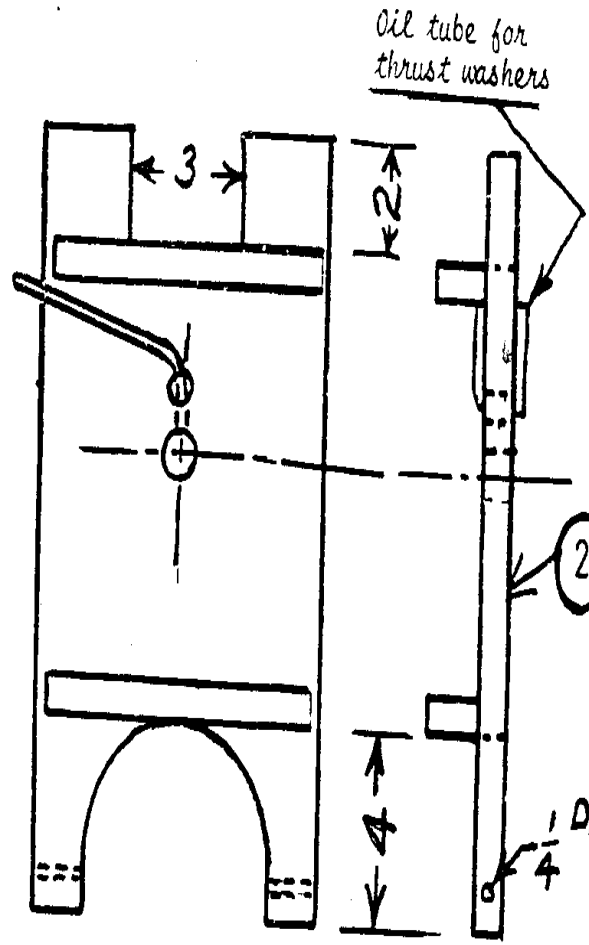

④ Center Bulkhead. Overall dimensions same as detail ③, note other variations.

well greased and in place work epoxy all around the shaft until it fills the space between the 3/4" diameter shaft and the 1" diameter hole. Remove the shaft and bore the oiling hole after epoxy has hardened and you will have very

satisfactory bearings.

(25) See Part (2).

hfm025.gif (317x393)

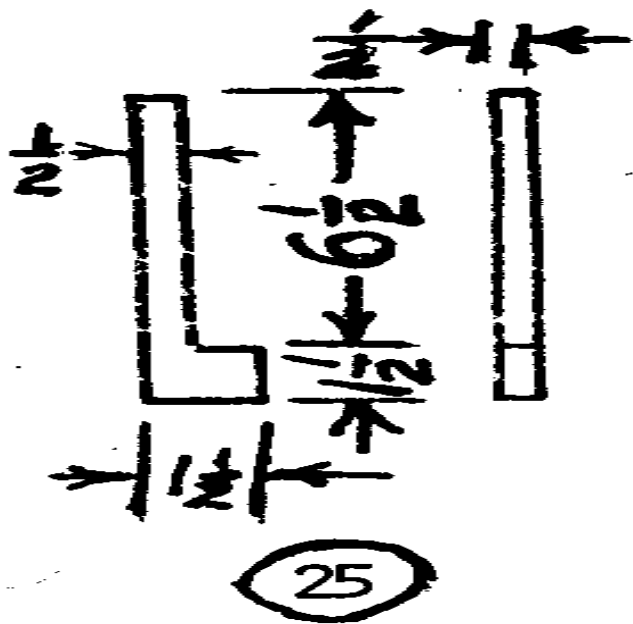

hfm002.gif (540x540)

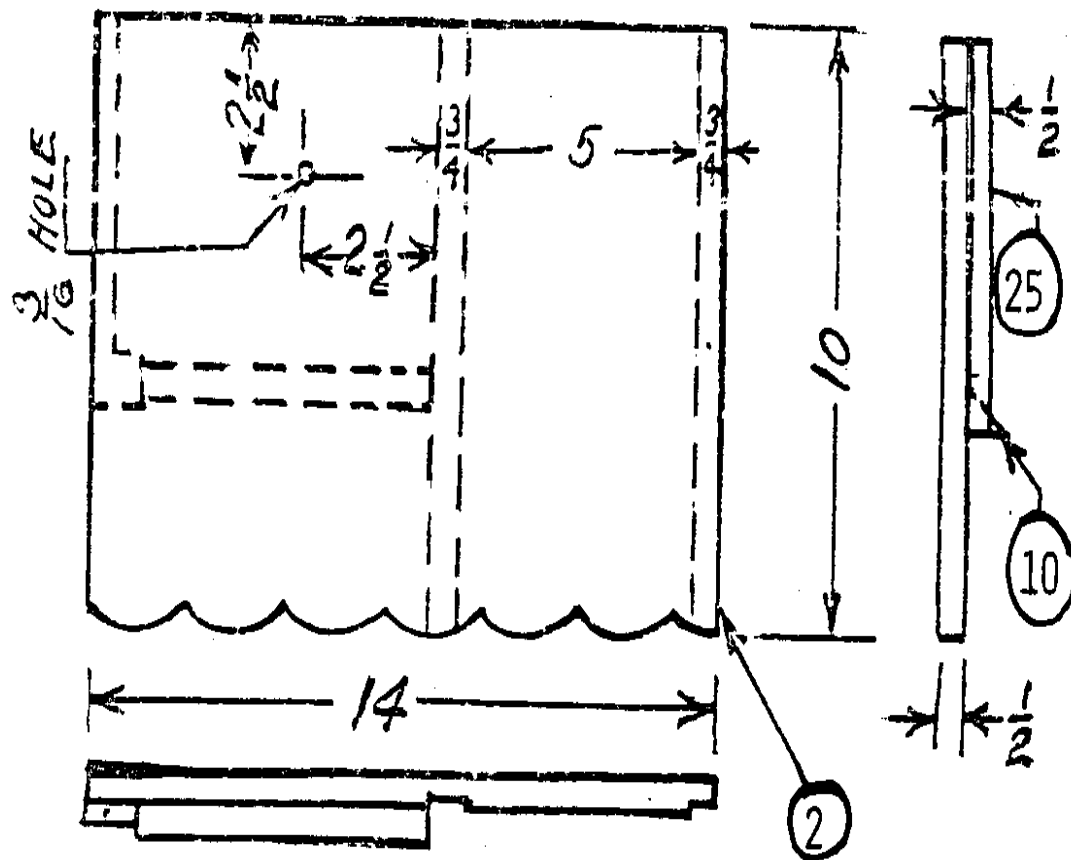

② Subassembly, Right Side.
For other dimensions see ①.

(26) Meal Bin.

hfm026.gif (186x437)

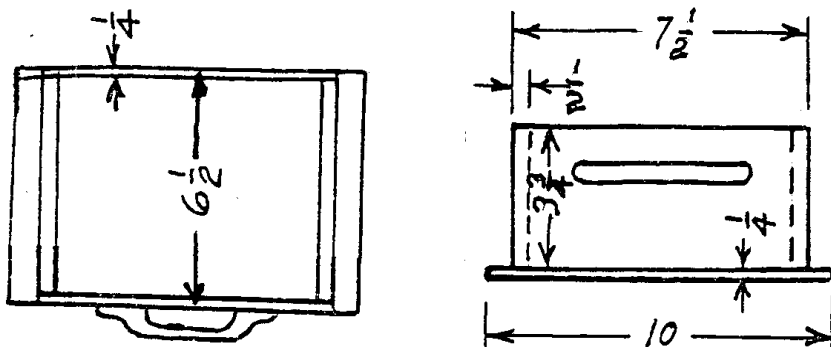

(27) This part is a 3/16" x 2" round headed stove bolt having a winged nut turned on it clear to the head. In turning the winged nut on, just before it reaches the head work epoxy well into the threads so it will be tight on the threads.

(28) See main assembly drawing on mill.

hfm028.gif (285x353)

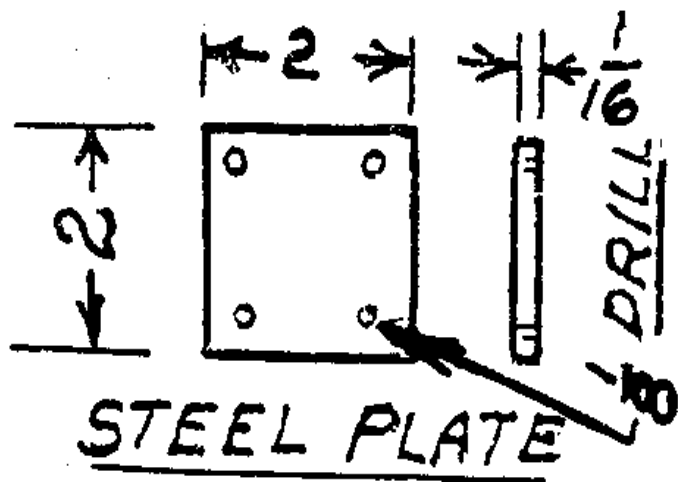

Also see detail (15).

hfm0150.gif (437x437)

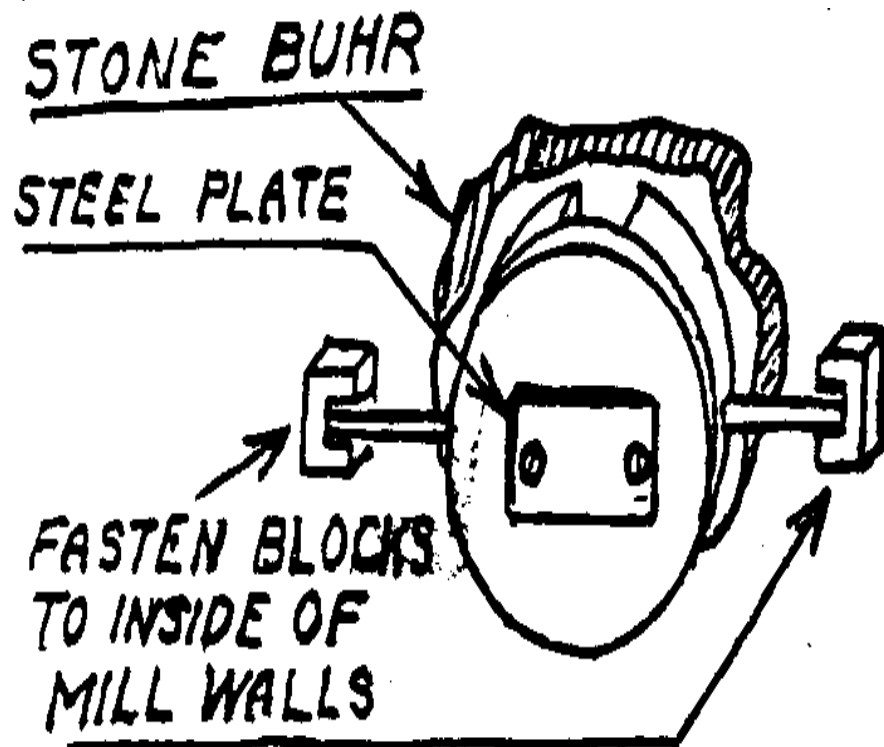

VITA Technical Bulletins offer do-it-yourself technology information on a wide variety of subjects.

The Bulletins are idea generators intended not so much to provide a definitive answer as to guide the user's thinking and planning. Premises are sound and testing results are provided,

if available.

Evaluations and comments based on each user's experience are requested. Results are incorporated into subsequent editions, thus providing additional guidelines for adaptation and use in a greater variety of conditions.

=====
=====