

[Alex Weir HomePage](#)

List of Contents

INTRODUCTION 1999.....[Thr010.htm](#)

OTHER REPORTS BY ALEX WEIR.....[Thr020.htm](#)

THE DYNAPOD / PEDAL POWER UNIT CONCEPT[Thr030.htm](#)

ACKNOWLEDGEMENTS.....[Thr040.htm](#)

INTRODUCTION.....[Thr050.htm](#)

LITERATURE REVIEW.....[Thr060.htm](#)

CONCLUSIONS FROM LITERATURE REVIEW.....[Thr070.htm](#)

RECOMMENDATIONS.....[Thr080.htm](#)

THRESHING TESTS.....[Thr090.htm](#)

DESIGN CONSIDERATIONS - THRESHING MECHANISM.....	Thr100.htm
DESIGN CONSIDERATIONS - GRAIN MILLING UNIT.....	Thr110.htm
DESIGN CONSIDERATIONS - POWER PRODUCTION.....	Thr120.htm
THRESHER DESIGN ADOPTED.....	Thr130.htm
GRAIN MILLING UNIT DESIGN ADOPTED.....	Thr140.htm
POWER PRODUCTION AND TRANSMISSION ADOPTED.....	Thr150.htm
PRODUCTION TECHNIQUES.....	Thr160.htm
CAPITAL EQUIPMENT FOR THRESHER PRODUCTION.....	Thr170.htm
PRODUCTION COSTINGS (ESTIMATE)	Thr180.htm
PREDICTED OUTPUT LEVELS.....	Thr190.htm
OPERATIONAL COSTINGS.....	Thr200.htm
MATERIAL REQUIREMENT.....	Thr210.htm

ADDITIONAL TESTING AND EXTENSION.....[Thr220.htm](#)

CONCLUSIONS.....[Thr230.htm](#)

RECOMMENDATIONS.....[Thr240.htm](#)

REFERENCES[Thr250.htm](#)

MISCELLANEOUS STRESS CALCULATIONS.....[Thr260.htm](#)

EARLY DESIGNS - A 2 MAN PEDAL THRESHER-Photo.....[Thr270.htm](#)

THE 4 MAN PEDAL THRESHER / MILL-Photo.....[Thr280.htm](#)

Chart 1 of 1 - Endurance.....[Thr290.htm](#)

Drawing 1 of 21.....[Thr310.htm](#)

Drawing 2 of 21.....[Thr320.htm](#)

Drawing 3 of 21.....[Thr330.htm](#)

Drawing 4 of 21.....[Thr340.htm](#)

Drawing 5 of 21.....[Thr350.htm](#)

Drawing 6 of 21.....[Thr360.htm](#)

Drawing 7 of 21.....[Thr370.htm](#)

Drawing 8 of 21.....[Thr380.htm](#)

Drawing 9 of 21.....[Thr390.htm](#)

Drawing 10 of 21.....[Thr400.htm](#)

Drawing 11 of 21.....[Thr410.htm](#)

Drawing 12 of 21.....[Thr420.htm](#)

Drawing 13 of 21..... [Thr430.htm](#)

Drawing 14 of 21.....[Thr440.htm](#)

Drawing 15 of 21.....[Thr450.htm](#)

Drawing 16 of 21.....[Thr460.htm](#)

Drawing 17 of 21.....[Thr470.htm](#)

Drawing 18 of 21.....[Thr480.htm](#)

Drawing 19 of 21.....[Thr490.htm](#)

Drawing 20 of 21.....[Thr500.htm](#)

Drawing 21 of 21.....[Thr510.htm](#)

[Home](#)"" """"> [ar.cn.de.en.es.fr.id.it.ph.po.ru.sw](#)

[Home](#)

List of Contents

INTRODUCTION 1999.....[Thr010.htm](#)

OTHER REPORTS BY ALEX WEIR.....[Thr020.htm](#)

THE DYNAPOD / PEDAL POWER UNIT CONCEPT[Thr030.htm](#)

ACKNOWLEDGEMENTS.....[Thr040.htm](#)

INTRODUCTION.....	Thr050.htm
LITERATURE REVIEW.....	Thr060.htm
CONCLUSIONS FROM LITERATURE REVIEW.....	Thr070.htm
RECOMMENDATIONS.....	Thr080.htm
THRESHING TESTS.....	Thr090.htm
DESIGN CONSIDERATIONS - THRESHING MECHANISM.....	Thr100.htm
DESIGN CONSIDERATIONS - GRAIN MILLING UNIT.....	Thr110.htm
DESIGN CONSIDERATIONS - POWER PRODUCTION.....	Thr120.htm
THRESHER DESIGN ADOPTED.....	Thr130.htm
GRAIN MILLING UNIT DESIGN ADOPTED.....	Thr140.htm
POWER PRODUCTION AND TRANSMISSION ADOPTED.....	Thr150.htm
PRODUCTION TECHNIQUES.....	Thr160.htm

CAPITAL EQUIPMENT FOR THRESHER PRODUCTION.....[Thr170.htm](#)

PRODUCTION COSTINGS (ESTIMATE)[Thr180.htm](#)

PREDICTED OUTPUT LEVELS.....[Thr190.htm](#)

OPERATIONAL COSTINGS.....[Thr200.htm](#)

MATERIAL REQUIREMENT.....[Thr210.htm](#)

ADDITIONAL TESTING AND EXTENSION.....[Thr220.htm](#)

CONCLUSIONS.....[Thr230.htm](#)

RECOMMENDATIONS.....[Thr240.htm](#)

REFERENCES[Thr250.htm](#)

MISCELLANEOUS STRESS CALCULATIONS.....[Thr260.htm](#)

EARLY DESIGNS - A 2 MAN PEDAL THRESHER-Photo.....[Thr270.htm](#)

THE 4 MAN PEDAL THRESHER / MILL-Photo.....[Thr280.htm](#)

Chart 1 of 1 - Endurance.....[Thr290.htm](#)

Drawing 1 of 21.....[Thr310.htm](#)

Drawing 2 of 21.....[Thr320.htm](#)

Drawing 3 of 21.....[Thr330.htm](#)

Drawing 4 of 21.....[Thr340.htm](#)

Drawing 5 of 21.....[Thr350.htm](#)

Drawing 6 of 21.....[Thr360.htm](#)

Drawing 7 of 21.....[Thr370.htm](#)

Drawing 8 of 21.....[Thr380.htm](#)

Drawing 9 of 21.....[Thr390.htm](#)

Drawing 10 of 21.....[Thr400.htm](#)

Drawing 11 of 21.....[Thr410.htm](#)

Drawing 12 of 21.....[Thr420.htm](#)

Drawing 13 of 21..... [Thr430.htm](#)

Drawing 14 of 21.....[Thr440.htm](#)

Drawing 15 of 21.....[Thr450.htm](#)

Drawing 16 of 21.....[Thr460.htm](#)

Drawing 17 of 21.....[Thr470.htm](#)

Drawing 18 of 21.....[Thr480.htm](#)

Drawing 19 of 21.....[Thr490.htm](#)

Drawing 20 of 21.....[Thr500.htm](#)

Drawing 21 of 21.....[Thr510.htm](#)

[Home](#)"" """"> [ar](#).[cn](#).[de](#).[en](#).[es](#).[fr](#).[id](#).[it](#).[ph](#).[po](#).[ru](#).[sw](#)

[Index.htm](#) [Thr020.htm](#)

INTRODUCTION 1999

This thresher was built in 1978 and this report was written in 1979. VITA of USA kindly published it. Recently I see that some current designs of man powered equipment for use in 3rd world locations are not any better than what I was doing 20 years ago. And opportunities and media (e.g. the Internet) for dissemination of information have bettered by leaps and bounds during those 20 years. Regrettably also many 3rd world economies for a variety of reasons have stagnated or gone backwards during the last 20 years. So this kind of stuff may still be valid.

So I take the liberty of reissuing the VITA report with a few very minor changes, with the addition of some photos, and with a little summary (immediately below) of some of the options for design of this kind of stuff, and some tips and tricks.

This report is web-ready, and can also be viewed from local hard disc. The web pages can be viewed by any browser.

Alex Weir November 1999.

Alexweir1949@YAHOO.COM

[Home](#)"" """"> [ar.cn.de.en.es.fr.id.it.ph.po.ru.sw](#)

[Index.htm](#) [Thr030.htm](#)

OTHER REPORTS BY ALEX WEIR

4 MAN PEDAL GRAIN THRESHER AND GRAIN MILLING UNIT

2 MAN LOW LIFT TROLLEY WATER PUMP

WOODEN BEARINGS - MATERIALS AND LUBRICATIONS

All are available free of charge via email from alexweir@usa.net in .htm format for viewing from local hard disc. They are also intranet and internet ready. There may be some more by the time you read this - send me an email to check it out.

[Home](#)"" """"> [ar.cn.de.en.es.fr.id.it.ph.po.ru.sw](#)

[Index.htm](#) [Thr040.htm](#)

THE DYNAPOD / PEDAL POWER UNIT CONCEPT AND VARIOUS DESIGN ALTERNATIVES - some thoughts and overview , tricks and tips (1999)

Action or Mechanism -

Pedalling, treading or rowing action. Most of my / our work at Morogoro concentrated on pedalling, but at the end we made a really nice 2-man rowing action (trolley) water pump. That was real inexpensive and very effective, and that rowing concept can easily be extended to 4 persons sitting side by side and back to back together (like a Zundap Janus). Even 6 or 8 person designs could be made cheaply. But sliding action is kind of limited to water pumping, and could possibly be extended through 2 pulleys to powering a traditional mortar and pestle grain milling unit (if that makes any sense). Sure it could also be hitched to a crank

To give rotary action but then most of the saving and simplicity is gone. Note that for our trolley system the 2 operators themselves are in pretty much constant motion, but that it should be equally possible to make the operators stationary and have only the drive shaft and footrests slide - there may be some advantages in that, e.g. increased efficiency.

Even rowing with a rope and drum and a freewheel mechanism, with or without a spring, might make some sense for some application. The freewheel from a bicycle could be used.

Treading - we never did of that, but maybe again for 4,6 or more persons that would make some sense, either with treading from a standing position or seated or semi-seated. Or some pedalling / treading hibred - say one long crankshaft with throws for 4 - 6 - 8 or more persons, or 2 bearing units with 2 long planks joining the 4 pedals and room for 4 - 6 - 8 or more pedallers in between those 2 bearing units.

Position - all our pedalling designs were conventional upright, but maybe for cost reasons

sometimes designs with a reclining pedaller or pedallers might make sense, especially if 2 persons can sit facing reclining and working together on one set of pedals - that saves a lot of chains, bearings, belts steel, wood etc etc.. A very small, compact, light and inexpensive unit could be built around 4 people facing each other pedalling one crankshaft, with a second layshaft running at 2.5 times the speed of this main crankshaft. Each of these 2 shafts could offer chainwheel, 600mm diameter pulley, direct shaft/ flexible coupling drive and possibly the initial crankshaft could offer small sprocket drive also (to enable stepdown to 20 rev/minute). If a flywheel is required for anything it can be fixed onto the direct shaft drive. The more I think about this machine the more excited I get - I probably recommend that such a design supercedes the power generation and transmission configuration as shown in the photos and drawings in this report.... Contact me on alexweir@usa.net if you want more details on this idea.

Handlebars - we tended to make home-made copies of conventional cowhorn shape handlebars, usually height adjustable.

Saddles/seating - Wooden or leather sprung or wooden padded. Height adjustable or not

Plastic seating, wooden seating, with or without padding. Wooden padded was probably the best and most cost effective option. Our wooden seats had the 3 fastening and locating holes in the same place as the real thing so that substitution either way could be performed.

Wooden saddles were less likely to get stolen.

Pedals - Conventional bicycle or wooden with metal spindle or split plastic pipe.

Solid wooden or split wooden (for easy replacement).

Bearings and Power Transmission

- 4 independent pedal bearing units (PBUs - pedals, cranks, spindle, bearings and bearing housing) with cycle bearings
- 4 independent PBUs with ball bearings
- 4 independent PBUs with wooden bearings
- solid wooden vs split wooden bearings
- crankshaft gang of 2 with roller bearings
- crankshaft gang of 2 with wooden solid or split bearings

Most of our designs used options (1), (3) or (6) above, without problems and with plenty of success. We tended to use solid wooden rather than split wooden since we stupidly did not

lay enough emphasis on future serviceability. Our PBUs of types (1) and (3) above were largely interchangeable - by loosening a clamping setscrew on the dynapod frame a PBU could be removed and replaced by another of the same or another type.... By and large wooden bearings were OK for the first stage of transmission at about 60 rev/minute, but not for higher speeds.

Usually these choices are down to the more expensive solution saving some human energy loss or wastage, and often also requiring more sophisticated capital production equipment and/or higher skilled personnel for production and assembly. Choice depends on the economics. If possible of course design with upgrades or downgrades in mind so that the machine can be changed to use the alternatives if and when more (or less) money becomes available and/or when a maintenance activity is required - but that is not often that easy in practice.

Chain, Belt and Shaft Drive

Bicycle chain drive proved very effective for a number of devices. Belt drive was probably

required for high speed equipment such as the centrifugal pump (3500 rev/minute) and for the winnowing fan (1000 rev/minute). Some stuff we built using direct shaft drive, with flexible couplings - that was very effective also - e.g. a larger grain mill driven at 60 rev/minute from the end of a single pedal unit shaft - at first from memory we used a commercial flexible coupling (e.g. manufacturer Fenner from UK), then we worked out how to make our own with the rubber disc made from old car tyre - highly effective. The thresher/mill in this report has a nice layshaft running at 200 rev/minute. The mill is shown here as an integral unit, but anything could be pulled on to the end of that layshaft using a flexible coupling or a direct solid coupling and a torque arm (if the device is light enough).

Wooden vs Steel Frame construction - at the start (Uganda 1972) I was a bit over the top with wood, thereafter I was a bit over the top with steel. Stupid really. It should depend very much on the relative costs of sawn timber vs. Steel sections and their relative strengths and the cost of fastening techniques. We never really checked out that kind of stuff - bad. And what about unsawn timber, bamboo etc - interesting possibilities - also to combine some traditional materials such as unsawn timber and bamboo with modern joining techniques and some modern but relatively low cost components.

Flywheels - the original flywheels of solid cement in bicycle rim and spokes were very effective

but a bit heavy. Maybe keep the inner ring free to loose only a small bit of the flywheel effect but to lose a lot of the weight. That was a copy from a VITA report on a wood turning lathe. The thresher as per this report does not need a flywheel - the drum itself has enough momentum. A plate mill type grain mill running at 200 rev/minute with 4 pedallers does not need a flywheel, but a single operator running at 60 rev/minute would need one. The one-man and 2-man pedal piston water pump designs used a steel rail (as in disused rail track) hexagonal flywheel arc welded together which was very effective - not too heavy but with plenty of momentum.

Applications -

Threshers are covered here

Grain Mills are covered here and/or are easy to adapt

It might be possible to drive a small laboratory-type hammer grain mill (or home-made copy of that design) as fast as 8000 rev/minute using 2 stage belt drive. We never went that far.

Maize shellers - we adapted a small commercial single-hole maize sheller from 60 rev/minute hand cranking to 200 rev/minute chain drive from pedal mechanism (see photo in this report). Also a commercial hand cranked 2 hole maize sheller again from 60 rev/minute hand cranking to 200 rev/minute belt drive from pedal mechanism (see photo in this report).

Winnowers - we never messed with the sophisticated ones with shaker trays and sieves, but made a nice one with a plastic car fan running from a single pedal unit at approx 1000 rev/minute through single stage belt drive using hollow circular polyurethane extrusion emergency fan belting. The airflow at about 30 degrees from horizontal blew between a hopper and collection sack with holder. Such a unit could be easily made as an add-on to the machine described here. I would recommend a home made sheet metal fan cut from one piece of 0.45 mm thick galvanised steel sheet and bent to shape. We used a bicycle front hub for the fan bearing unit with a small (30mm diameter) 2-piece wooden pulley sitting on the other end of the spindle from the fan.

Water Pumps - we made a nice 4 man pedal centrifugal water pump running at 3500 rev/minute through a 2 stage chain and then belt drive. We sold that to UNICEF and it finished up at Karen Village Technology Centre Nairobi before parts got stolen or removed from it. But small centrifugals are a bit inefficient, so we moved on to the 2 man Trolley Pump design. We actually had to play with (cut and shorten) the sealing spring on that unit to reduce drag and efficiency losses to an acceptable level. There could still be some mileage in that kind of design, depending on cost of the pump. One could even probably fabricate the pump body on a small-scale basis but buy in the plastic impellor, seal and spring (and of course bearings).

It could be interesting to design and produce a hybrid wind-powered and man-powered pump based on the 2 man trolley pump unit... In fact any wind powered unit should always consider man or animal power as a backup strategy for windless periods.

Sugar Cane Crushers - we made a nice one of these for animal power, using 2 x 6 inch diameter (150mm) steel pipe rollers with gripping splines created by arc welding, and running in wooden bearings of about 30mm diameter (from memory). We powered it by the ox pulling a rope running around one of those rollers extended, therefore powering only on the outward walk and resting on the way back in (the walk was about 30 metres I guess). That project was really popular because the stuff turns into alcohol with almost no encouragement... To change that design to use ball or roller bearings would produce a very big improvement in efficiency.

Summing up, we tried a lot of stuff, some of it undocumented (and even regrettably without photos - we should have snapped everything we made in those days - most of it was good). And there were ideas we should have tried out which we didnt. Anyone doing any kind of stuff like this needs to keep a very open mind. Feel free to run ideas across me anytime by email at alexweir@usa.net.

[Home](#)"" """"> [ar.cn.de.en.es.fr.id.it.ph.po.ru.sw](#)

[Index.htm](#) [Thr050.htm](#)

ACKNOWLEDGEMENTS

Thanks must go to Dick Finlay of IDRC Canada / University of Dar es Salaam Morogoro, Howard Hepworth of Ilonga Research Station, and the late Kenelm Rayner of Morogoro Diocese Tanzania for requesting grain threshing devices.

To VITA, ITDG and various other sources for supplying literature. VITA were especially efficient and fast in that regard.

To technicians Adolf Kessy, John Mzuanda, John Sokoro, and to students Mwidadi Mdee and John Shetui for help in producing and testing various threshers, both engine and man-powered.

To Henrik Have, Frank Inns, Dean Kyomo, Professor Kimamba, Vice-Chancellor Msekwa, and Vice-Chancellor Kaduma and others of the University of Dar es Salaam for encouragement.

To the University of Dar es Salaam and to the British Ministry of Overseas Development (BESS) for paying my wages.

To various organisations and individuals who requested copies of this report.



Rogues Gallery of some of us in the Morogoro days - I am the badly-dressed white guy with the beard. Shame we didnt take more photos. Anyone in this photo who wants a full-sized copy just email me.

[Home](#)"" """"> [ar.cn.de.en.es.fr.id.it.ph.po.ru.sw](#)

[Index.htm](#) [Thr060.htm](#)

INTRODUCTION

Threshing is the action of separating the grain, for example of cereals, grain legumes or grasses, from the stalk of the plant. One traditional method of threshing is that of beating the

plants with a wooden stick or with a hinged wooden flail, with the heads of the plant inside a sack, or with the unenclosed heads lying on a mud or concrete threshing floor. Another traditional method is to drive cattle repeatedly over the plants so that threshing occurs by the action of the hooves. An improvement on that technique is to use an animal-drawn threshing sledge or threshing rollers. The main problems of these types of animal-powered threshing are fouling, burying or cracking of the grain. These human and animal-powered methods of threshing are still widely used.

In the 18th Century, rotating threshing mechanisms were effectively used for the first time (Meikle), and are nowadays commonly found as part of combine harvesters, which perform the functions of cutting, feeding, threshing, winnowing, cleaning, grading, conveying and bagging. In most so-called Developed Countries, high agricultural wages render less mechanised techniques uncompetitive when compared with combine harvesting. Despite this, a few European countries still produce power-driven threshers, for use on experimental plots and for export. Combines are economically and technically effective when operating in large well-cleared fields of monoculture, with reasonably high yields per hectare, and with plants of low-to-medium height. These conditions often do not exist in present-day tropical farms.

Though not of immediate relevance, it must be mentioned that in recent years in some Developed Countries, adverse weather conditions during harvesting have led to some interest in merely harvesting plant heads in the fields, possibly with a tractor-driven flail-type forage harvester, and then performing threshing and subsequent operations at the farmstead.

In Tanzania, maize, cassava, and sorghum and millet are the principal staple foods. Wheat and rice are grown mainly for urban consumption, and some sorghum and millets are also grown for the production of local beers. Combine harvesters are used on large-scale state and private farms- mainly for maize at Iringa and for wheat at Arusha, both these areas being fertile with relatively high yields per hectare. Combines are not usually used for sorghum and millet, except on seed schemes, because yields are usually relatively low and because most production is by villagers and small-holders on relatively small and uncleared plots. One reason why yields are relatively low is that sorghum and millets are drought-resistant crops which are usually grown on land with average rainfall too low to justify the growing of maize. Moreover, despite crop-breeding work on high-yielding dwarf varieties, most sorghum and millets grown in Tanzania are traditional low-yielding tall local varieties.

It was brought to the attention of the Writer, by crop production and agricultural extension personnel, that there was a need for low-cost threshing equipment for village use, particularly for sorghum and millets, which have a high specific energy requirement for threshing when compares with such crops as maize or cowpeas.

This report details one particular design of man-powered thresher, which evolved after 4 years of occasional work on man-powered and engine-powered threshers.

The thresher described incorporates a grain mill, and thus it is necessary to provide some background information on milling.

In most parts of Tanzania, and in many other countries, cereals are the staple food and they are usually consumed as porridge made from fine flour. The traditional technique for obtaining this flour is for one or several women to pound and re-pound the grain with what is effectively a large wooden mortar and pestle. This is often done on a day-to-day basis, mainly because flour is much more susceptible to attack from insects and dampness, but also because pounding is rather hard work.

The modern technique of milling uses a co-operatively or privately-owned diesel- or electrically-driven hammer mill, whose steel beaters travel at an angular velocity of typically 3000 rev/minute and a milling velocity of around 70 metre/second. These beaters shatter the grain on impact. Hammer mills have been manufactured on a small scale in Tanzania for some years now, and it is probable that half of the population lives within 10 kilometres of such a power mill. Current charges for power milling are in the region of US\$ 0.040 per kg, compared with a grain value for maize or sorghum of around US\$ 0.220 per kg (1976 prices). People walk or cycle long distances to get their grain milled at a power mill, partly because of the fine flour obtained from the hammer mill and partly because of the heavy labor required for pounding.

"Plate" Mills or "Burr" Mills, both hand and engine-powered, have apparently been used in

West Africa for some years, but have not become popular in East Africa.

[Home](#)"" """"> [ar.cn.de.en.es.fr.id.it.ph.po.ru.sw](#)

[Index.htm](#) [Thr070.htm](#)

LITERATURE REVIEW

Kline (1969) stated that pedal-operated or hand-operated drum threshers, common in Asian rice-growing countries, were rarely used in Equatorial Africa (it is almost certain that by 'pedal-operated' he meant in fact 'treadle-operated'). A few models had been brought in for trial by various governments, but up till then they had not been actively promoted by the agricultural extension services. Kline further stated that due to the increase in rice-growing in several African countries, there was a place for a small hand-operated grain thresher which could be adapted to engine power later. However, he did add that most treadle-operated and hand-operated threshers were very tiring to operate.

According to Hopfen (1960), treadle-driven drum threshers were satisfactory only when the grain was easily detachable from the stalks, as with rice, but not with wheat or barley.

Haynes (1964) stated that outputs of 7 - 8 kg per woman per hour were observed for hand threshing of rice in Northern Nigeria.

Islam (1977) stated that hand beating of rice produced 18 kg per man per hour, and that the output from treadle threshing is about 42 kg per man per hour.

Johnson (1966) , from tests with a treadle thresher at IRRI, on rice at 25% moisture content, quotes average figures of 20 kg per woman per hour for threshing and bagging; and 12 kg per woman per hour for gathering, threshing and bagging.

Sutton (1969), using a drum thresher driven by a 1.7 kilowatt petrol engine, quoted outputs of 230 - 690 kg per hour for rice. The machine was of rasp-bar type, drum size 300mm diameter x 300 mm width, drum speed 1500 rev/minute for rice and 860 rev/minute for beans, sorghum and other crops.

Arnold (1964) , from instrumented experiments, gave the specific threshing energy requirement for wheat to be in the range of 0.77 kilowatt-hour per tonne.

VITA (1977) listed 15 manufacturers who produce small-scale threshers for rice and other crops, but without detailing which threshers were engine-driven and which were man-powered.

The Alvan Blanch company (UK) (1976) listed specifications of their 3 tractor-powered and engine-driven threshers.

CADU (1976) gave details of their experimental non-cleaning thresher powered by a 6 kilowatt

engine.

The John Darbyshire company (UK) (1972) exhibited a one-man pedal-driven rasp-bar thresher with belt drive, mounted on skids for field transport.

The Indian Standards Institute (1965) issued a specification for treadle-driven rice threshers: the drum to have wooden slats with wire hoops, drum 400 - 430 mm diameter x 450 - 700 mm width. Drum to be gear driven from the treadle at 400 rev/minute through a gear ratio of greater than 3.5 : 1. Total machine weight to be 30-40 kg.

ITDG (1974) published constructional details of a hand-powered guinea-corn (sorghum) thresher developed in West Africa.

Malaya College of Agriculture (1967) issued a report and drawings of a peanut thresher, of mainly timber construction, using a drum with 4 wooden beaters. Bicycle hubs were used as bearings, and power was provided by one person through either a bicycle chain treadle drive or a flat belt pedal drive.

VITA (1972) circulated plans for a treadle-driven rice thresher of wooden construction, using wire hoops for threshing, with a rope drive system.

Jamanre (1970) produced plans for a wire hoop treadle thresher of steel construction with a 400mm diameter drum and a 3.3 gear ratio chain drive.

Suggs (1970) produced plans for a one-man pedal thresher for soya beans, using flat belt drive of gear ratio 3. Mainly wooden construction. Drum 500mm diameter x 800mm width. 20 flat wooden beaters.

The following table by Krendel (1963) gives formulae for endurance curves describing the maximum working performance of 'average; European male laborers, assuming 20% conversion efficiency in the muscles of food energy to mechanical work.

Age (years)	Useful Mechanical Power (Watts)
20	$290 - (33.6 \times \ln (t))$
35	$260 - (29.8 \times \ln (t))$
60	$220 - (24.9 \times \ln (t))$

Where t is in minutes, and t ranges from 4 minutes to 480 minutes

For pedalling, presumably by well-trained young athletes, Krendel (1963) gives the following

endurance curve:

$$P = 395 - (42.1 \times \ln(t)) \text{ watts where } t \text{ is } 1 \text{ through } 100 \text{ minutes}$$

Krendel (1963) also stated that optimal human muscle energy conversion efficiency is 25% and that this maximum efficiency occurs when the force exerted by the muscle is about 50% of maximum and the speed of muscle movement is about 25% of maximum. He further stated that optimal conversion efficiency and maximum power output do not occur together.

Based on German, French and Italian experimentation with man-assisted gliders in the 1920s, Krendel (1975) gave the following endurance curve formulae:

For a strong, but not highly trained cyclist:

$$P = 670 \times (t) \exp(-0.39) \text{ watts}$$

Where $t = 5$ to 60 minutes

For a renowned racing cyclist;

$$P = 1490 \times (t) \exp(-0.42) \text{ watts}$$

Where $t = 5$ to 60 minutes

Krendel (1963) stated that for steady-state activity, mechanical power production depends on the oxygen supply and the efficiency with which oxygenated blood can be transported to the muscles.

VITA (1975) stated that the muscle-mass of the legs is more than large enough to utilise all the oxygen that can be absorbed, and that overall efficiencies of around 25% have been achieved for bicycle-type mechanisms. However, the muscles of the arms alone are not of sufficient mass to utilise completely the available oxygen, and overall efficiencies for arms alone are only about 16%. The maximum efficiencies which have been measured in practice have been for cycling mechanisms.

Wilkie (1960) stated that rowing is a relatively uneconomical method of producing external mechanical work because of the disproportionate wastage of energy due to the acceleration and deceleration of the whole body.

Sutton (1974) , in an experimental study of various types of man-powered winnowing devices, found by the use of respirometers that pedalling had 14 - 34 % ergonomic advantage over hand-cranking when gross power expenditure was greater than 350 watts; however pedalling was found to have 7 - 103% disadvantage when gross human power expenditure was less than 175 watts.

Addendum 1999 - Weir - Note that average male food consumption per day is 3,100 kilocalories, which is equivalent to about 3.5 kilowatt hours of energy. Therefore one can reasonably assume that 1 kilowatt-hour of mechanical energy per day per person is a probable upper limit for man-powered equipment, regardless of over how many hours or minutes that energy is produced and by what mechanism.

For Milling Grain, Omar (1977) showed that the traditional practice of pounding appeared to require 1.3 to 1.7 times the specific energy required by a plate mill utilising roller bearings. He also determined that the 'Hunts Minimill' (UK) used required a torque input of 26 Newton-metres when milling low moisture content maize to a fineness modulus of 2.4 .

The writer (1976) in unpublished tests, found that a 'home-made' mill with roller bearings throughout required only 80% of the specific energy required by a commercial mill, using the same plates, but with metal-to-metal journal bearings throughout.

Standard textbooks on milling, when comparing plate milling with hammer milling, state that plate milling is more efficient for coarse flour (e.g. for chicken feed), whereas hammer milling

is more efficient for fine flour (by a factor of approximately 1.4 for maize of fineness modulus 2.4).

The UK Tropical Products Institute (1977) exhibited a one-man-powered bicycle-mounted hammer mill, driven at high speed by a roller rubbing on the rear tyre of a bicycle mounted on its stand.

[Home](#) > [ar.cn.de.en.es.fr.id.it.ph.po.ru.sw](#)

[Index.htm](#) [Thr080.htm](#)

CONCLUSIONS FROM LITERATURE REVIEW

1. It would appear that for rice, the use of a treadle thresher multiplies labor productivity by a factor of 2.3 over hand threshing.
2. There is a distinct lack of similar data relating to crops such as sorghum.
3. Asian treadle rice threshers would appear not to be suitable for threshing other crops such as sorghum, millets or wheat (different mechanism and also different threshing speed).
4. There do not appear to be any effective prototype designs or commercial production of man-powered threshers for crops such as sorghum and millets.

5. For man-powered equipment, the use of leg-power appears technically preferable to the use of arm-power, except for low power requirements. However it was not possible to find any experimental data comparing treading with pedalling (or with rowing).
6. Using energy considerations, for the production of fine flour, the hammer mill is preferable to the roller-bearing plate mill; this is better than the journal bearing plate mill, which in turn is superior to traditional pounding.

[Home](#)"" """"> [ar.cn.de.en.es.fr.id.it.ph.po.ru.sw](#)

[Index.htm](#) [Thr090.htm](#)

RECOMMENDATIONS

1. It would appear necessary to conduct some tests to check if (as for rice) a human powered threshing mechanism results in significant increase in labor productivity over traditional hand-beating methods.
2. Should these tests prove affirmative, then there could be 3 possible solutions to production of human-powered threshers for sorghum and millets:
 - adapt treadle rice threshers by removing wire hoops, fitting wooden beater bars, and fitting a stator board with approximately 10mm clearance from the drum beater bars;

also maybe reducing the threshing speed by approximately 40% by gearing or by operator.

- adapt parts of or a complete small engine powered thresher of suitable design to be powered by one or several persons, utilising a treadle or pedal or rowing system or some other kind of human mechanical drive.
 - Design a machine from basics
1. Should it prove convenient, the utility and utilisation of such a thresher could be improved by the incorporation or attachment of a hammer mill or a roller-bearing type plate mill for grain milling. Or a general purpose drive which could power devices such as winnowers, maize shellers, water pumps etc..

COURSE OF ACTION

Some energy comparison tests were conducted at Morogoro, and are presented below.

It was decided to design a machine from basics, and the results of that are contained in the main body of this report below. However options (1) and (2) within Recommendation (2)

above may still be valid in some circumstances.

[Home](#)"" """"> [ar.cn.de.en.es.fr.id.it.ph.po.ru.sw](#)

[Index.htm](#) [Thr100.htm](#)

THRESHING TESTS

Near the beginning of the program of thresher development, the following tests were performed:

1. In February 1974 the first prototype pedal thresher was tried out. Drum diameter 400mm, driver pulley 630mm diameter, driven pulley 80mm diameter, belt drive. Drum speed 525 rev/minute. Beater velocity 10 metres/second. The writer pedalled while 2 others fed heads of sorghum to the beater-stator interface. The particular thresher utilised wooden bearings throughout, and , under zero load, static torque requirement at the pedals was 9 Newton-metres (that gives 54 watts energy loss while pedalling at 60 rev/minute - a bit unacceptable). After 20 minutes continuous threshing, the collected grain was winnowed and weighed at 11.5 kg. The pedaller subjectively felt his endurance at that (unknown) power output would have been 30 minutes maximum.
2. In the same week, some sorghum heads of 18% moisture content were placed in a jute sack and beaten by the writer to his endurance time - 10 minutes in this case. It was visually estimated that only 50% of the grain had been threshed, and after winnowing

the sample was weighed at 5.2 kg.

3. On the same day, some sorghum heads of 13% moisture content were placed in a sack and beaten as before with a wooden stick. 5 minutes of threshing produced 3.16 kg of clean grain, with an estimated 0.15 kg unthreshed. Endurance time again 10 minutes, and same operative (the writer).
4. Again on the same day, approximately 4 kg of cowpeas were hand threshed for 5 minutes. The work was extremely light compared with the previous 2 tests, and on inspection the cowpeas were entirely threshed.
5. Shemsanga (1975) conducted the following brief test for the writer - a 3 horsepower (2.25 kiloWatt) engine-driven rasp-bar thresher was used on the University Farm for threshing sorghum heads of low moisture content and moderate yield. Over 5 minutes, 15.63 kg of uncleaned sorghum was threshed, for a petrol consumption of 20 millilitres.

ANALYSIS OF THRESHING TESTS

From the data presented above, the following table can be derived:

Test Number	Output (kg/hour)	Power loss	Endurance time	Male Eur	Strong Cyclist	Net Spec. Energy Req	Net Spec. Energy Req
-------------	------------------	------------	----------------	----------	----------------	----------------------	----------------------

		(watts)	(minutes)	Labor <25yrs (1)	(2)	(kWh/Tonne) (1)	(kWh/Tonne) (2)
1 (machine)	34.5	54	30	170	177	3.1	3.3
2 (hand)	31.2	n.a.	10	220	273	5.8	7.2
3 (hand)	37.9	n.a.	10	220	273	4.6	5.8

TABLE I - Analysis of Sorghum Threshing Tests

Thus if one neglects the power input of the people feeding heads to the thresher (!), and if one assumes the use of an efficient power transmission (with effectively zero power loss), then it appears that for sorghum the use of a pedal thresher multiplies labor productivity by 1.9 to 2.2 over hand threshing. That compares with Islam's factor of 2.3 for the threshing of rice.

For Test # 4 (cowpeas) , power consumption was too low to be estimated (and anyway no comparable machine threshing was performed).

For Test #5, thresher output was 187.6 kg / hour for petrol input of 0.24 litre/hour. Assume calorific value of 10.5 kWh / litre, and engine thermodynamic efficiency of 15% to 25%. Thus specific energy requirement appears to be 2.01 - 3.36 kWh/tonne . That ties in with the calculated value of 3.1 - 3.3 kWh/tonne for pedal threshing as per Test #1 (Table I above).

Thus a pedal thresher appears to multiply labor productivity by a gross factor of 2.05 when compared with hand threshing, and a net factor of 1.37 if one considers a case with 4 pedallers plus 2 persons hand-feeding.

[Home](#) > [ar.cn.de.en.es.fr.id.it.ph.po.ru.sw](#)

[Index.htm](#) [Thr110.htm](#)

DESIGN CONSIDERATIONS - THRESHING MECHANISM

The wire hoop mechanism already mentioned is only really effective for rice. The peg-type mechanism is suitable for beans only. The rasp-bar-and wire-concave mechanism can be used for almost all crops, provided that clearance stators-to-beaters is correct and that beater speed is correct for the crop being threshed. These mechanism types are usually used on drum-type threshers, but an engine powered disc-type portable rice thresher was developed in recent years at IRRI, where the threshing was done in an axial and not a radial axis.

The first prototype pedal thresher constructed at Morogoro used plain wooden beaters with a wire concave, but separation of grain from the heads was found to be less than 95% with conventional semi-automatic feeding (letting the heads go into and through the beater/concave interface and into the output collection area). Therefore it was decided to adopt a feeding pattern similar to that used for treadle rice threshers - holding the heads at the beater-stator interface for about 1 second, and then withdrawing the heads. In this way, separation tended to 100%, and it was possible to dispense with the concave completely to save costs. With hindsight, the use of wooden beaters with a rasp pattern and a wire concave may have resulted in an acceptable degree of separation (and maybe not).

Thus a choice exists between a wire concave system with semi-automatic feeding and either cast-iron, steel or wooden rasp beaters; or a concave-less system with manual feeding and wooden or steel plain or rasped beaters. Concave-less design results in lower initial capital cost but higher real or effective labor costs. Concave-less also gives consistently high separation (if the feeders do their job properly). Steel beaters give better flywheel effect and lower wind / air resistance losses, but probably produce more grain cracking - we didnt experiment with steel beaters at all do we dont have experience. A flat-faced wooden (or steel) beater 25mm deep x 1000 mm wide in theory absorbs about 15 watts when travelling at 10 metres/second or 37 watts at 13.5 metres/second - probably not much compared with the power output of 4 operators.

Threshing velocity refers to the velocity of the beaters, hoops or pegs which strike and rub the heads of grain. Too high a velocity results in breaking or even shattering of the grain, thus

rendering it unsuitable for use as seed and making separation from the chaff extremely difficult. Too low a threshing velocity causes insufficient separation of grain from the plant head. Typical threshing velocities, as used by Sutton (1969) are 13.5 metre/second for sorghum, millets, wheat and beans, and 23.5 metre/second for rice. However a threshing velocity of only 8.4 metre/second is specified for the Indian treadle rice thresher (1965), which despite the low velocity ensures effective threshing by the hand holding of the heads in the beater-stator interface for 1-2 seconds. The design in this report utilises 13.5 metre/second.

[Home](#)"" """"> [ar.cn.de.en.es.fr.id.it.ph.po.ru.sw](#)

[Index.htm](#) [Thr120.htm](#)

DESIGN CONSIDERATIONS - GRAIN MILLING UNIT

Addendum 1999 - Note by the way that this machine can be produced as a thresher without the grain milling unit and also it can (with a lot of cutting) be produced as a mill without a thresher.

It is apparent that on energy grounds, hammer milling is preferable to plate-milling, which in turn is preferable to pounding.

TPI's (1977) method for obtaining high speed appears attractive but requires awkward fitting, ties up an important means of transport, and causes tyre wear.

Small laboratory mills designed to be powered by 1 kilowatt electric motors rotate at speeds of about 8000 rev/minute. The writer has obtained speeds of 3500 rev/minute from pedal powered systems (4 man centrifugal water pump, using 2 stage chain then belt drive) - thus 8000 rpm is probably feasible using 2 stage belt then belt drive, but power losses may eliminate some or all of the specific energy advantage of hammer over plate milling. Anyway we never got around to trying that out...

Using a roller bearing plate mill with plates like the Hunts Minimill would require 26 Newton Metres torque for fine flour. 4 pedallers doing 57 rev/minute with chain drive of ratio 44:18 would require 95 watts mechanical power per operator - that gives 151 minutes endurance for a 60 year old male European laborer - therefore quite a satisfactory solution.

Such a roller bearing plate mill can be made from scratch, or a standard journal-bearing-type plate mill can be adapted by installing a standard tapered roller bearing or ball type thrust bearing in place of the usual bronze thrust washer. Thus radial loads are still absorbed by the journal bearings but the much more energy-consuming thrust load is absorbed by the high-efficiency anti-friction bearing.

[Home](#)"" """"> [ar.cn.de.en.es.fr.id.it.ph.po.ru.sw](#)

[Index.htm](#) [Thr130.htm](#)

DESIGN CONSIDERATIONS - POWER PRODUCTION AND TRANSMISSION

Firstly, it would be desirable to design any man-powered device or thresher for easy conversion to electric motor or petrol or diesel engine power at a later date.

Of the conventional systems for utilising human power, treading or pedalling would appear better than hand-cranking, for moderate or high power requirements.

Pedalling would appear to be more efficient than conventional treading, but the system required is probably more expensive, especially for several operators. It could be worthwhile considering a seated operator or operators with single-acting or double acting treadle.

** Addendum 1999 - Weir - it could be interesting to extend the trolley mechanism used in my 2 Man Trolley Pump report to 4 persons, or even to 6 or 8 persons, and to link that reciprocating action to a rotary drive for threshing, milling, maize shelling, winnowing etc.. That path was never followed during those years. We didnt really do enough brain storming at the time or thinking seriously in terms of reuseable modules.

It has already been suggested above that a pedal thresher should utilise 4 pedallers and 2 feeders, operating in rotation. The conventional treadle rice thresher is usually operated by only one person at a time, but some Chinese treadle rice threshers are fairly long machines, designed for operation by several people at one time, and able to absorb the available power if motorised. This use of several operators at any time is bound to result in lower unit costs.

Several power transmission techniques were found in the literature - chains, V-belts, flat belts

and spur gears. Prototypes at Morogoro originally used a type of flexible V-belt (Eaton) of hollow circular polyurethane extrusion, which could be cut to the length required and joined with a bayonet type small aluminium (fixed) or steel (unscrewable) connector, but shock loadings resulted in excessive belt slippage which could have been fixed by increasing drum mass, flywheel effect and angular momentum. 2 stage chain drive proved fine for the model described in this report, provided all sprockets were properly aligned, ran true, chain tension was kept correct, and some occasional lubrication was used. Power losses in chain drive are usually quite low compared with belts.

Wooden bearings were used for the first prototype Morogoro man-powered thresher, resulting in high relative power losses. Therefore this design uses mainly ball bearings. We tend to go for double-metal-sealed (e.g. type 6204.2Z), since they have some protection against dust and lack of lubrication, but they have slightly increased drag and therefore energy loss when compared with unsealed bearings. We don't recommend double-rubber-sealed (e.g. 6204.2RS) since their drag and energy loss is higher.

It is always nice when building or designing a machine like this to make it modular, so it can drive other equipment which one just bolts on. The idea of a multi-purpose pedal system was proposed by Wilson (1971) who has since developed several pedal devices. At Morogoro our program (but it was never a formal Program) developed the following: a 2 man pedal piston pump, 4 man pedal centrifugal pump, one-man pedal grain winnower, one-man pedal grain mill, and one-man pedal maize sheller. We really didn't do enough to develop multifunctionality, modularity and interchangeability. Rodale (1978) as well as Wilson did

some work on the Dynapod multiuse concept.

When considering the plate mill, it is important to be able to remove the complete mill or at least the plates, since the dry rubbing of plates together for example when threshing not only loses power unnecessarily but also wears out the plates. The plate mill can be an integral part of the layshaft (as per the drawings in this report) or it could be driven from the layshaft by a flexible coupling or by a solid or semi-rigid bush. That flexible coupling / semirigid bush design option would just require that the mill was located by a torque arm of some kind, and would make removing and fitting the mill a quite simple operation.

Note that in fact the design as proposed here with the integral plate mill was never built - but we did plenty of work with pedal plate mills, on which this design is based. The integration of the plate mill is an attempt towards the ideal of modular design....

[Home](#)"" """"> [ar.cn.de.en.es.fr.id.it.ph.po.ru.sw](#)

[Index.htm](#) [Thr140.htm](#)

THRESHER DESIGN ADOPTED

It was decided to produce a 4-pedaller / 2-feeder thresher without concave, and with plain wooden beaters. The design includes a grain milling device although the unit produced did not have that feature.

For the thresher unit itself, 6 plain wooden beaters, each 1000 mm long x 75 mm wide x 25 mm thick spin at about 36 radians /second (344 rev/minute) at a radius of 320 mm, giving a beater velocity of 11.5 metre/second. Heads of sorghum or millet are fed by hand into the gap of approximately 10 mm between the beaters and the wooden stator board, which is adjustable after loosening the 2 clamping nuts. The heads, now with no grain, may be pulled back by hand from the threshing interface, or may be released from the feeder's grasp to pass through the machine with the threshed grain and chaff. The complete drum unit is covered in 0.45 mm thick galvanised steel sheet, which is pop rivetted or fastened by self-tapping screws to the machine frame. This cover stops grain flying all over the place and is also a safety device in the event of a beater breaking. There is only a small gap visible to the feeders. The output from the thresher is collected in a sheet metal collecting tray, on a tarpaulin, on a heavy duty polythene sheet, on sacks, or on a concrete floor at the drum exit. Separation and winnowing are NOT performed by the machine. The threshing technique requires, for the feeders' safety and convenience, that around 100mm of stalk be retained with the heads of grain during the harvesting operation.

The beaters are bolted to the 2 sets of 6 spokes, welded to 2 spoke hubs, which in turn are welded to the 25mm mild steel shaft. 2 alternative designs of spoke hubs are shown in the drawings for this report, depending on the sophistication of facilities available (e.g. indexing vice and pillar drill). The less sophisticated design requires slightly more skill during production, assembly and assembly welding, but both are OK. The shaft runs in 2 20mm bore double-metal-sealed ball bearings, which are located in locally-manufactured mild steel

bearing housings, bolted to the thresher frame, which is welded up from lengths of mild steel rectangular hollow section. These sections provide lightness, strength, and ease of welding.

Drive comes to the drum from a bicycle chain powering an 18 tooth sprocket welded to a hub, which is located on the thresher shaft by a keyway and nut. The keyway can be produced by a chisel by a skilled operator and does not need a milling machine or lathe with milling attachment.

The threshing drum is statically balanced on assembly by sawing or planing overweight beaters. Spacing washers are used if necessary to ensure that all beaters produce the same gap (about 10mm) with the stator board.

[Home](#) > [ar](#).[cn](#).[de](#).[en](#).[es](#).[fr](#).[id](#).[it](#).[ph](#).[po](#).[ru](#).[sw](#)

[Index.htm](#) [Thr150.htm](#)

GRAIN MILLING UNIT DESIGN ADOPTED

Is of the plate mill or burr mill type, and is incorporated on the cantilevered part of the layshaft. Grain is gravity fed from a hopper of some kind through a flexible tube to the mill, thus avoiding excessive bending and shearing of the layshaft. A torque arm, possibly assisted by a tension wire or string, prevents the mill body and the stator plate from rotating. The layshaft drives the rotating plate through a keyway and key, and milled grain comes out from

the outer rim of the 2 plates, falling by gravity for collection below. The axial thrust required for effective milling is produced by tightening the nut and locknut at the end of the layshaft, while stopping the layshaft from rotating by means of a pipe wrench or a large spanner on a specially-created flat on the layshaft itself (such a flat is not shown in the drawings). The thrust is absorbed by the tapered roller bearing, which also locates the plate flanges radially. The mill is designed to utilise 'Hunts Minimill' hardened steel milling plates, which locate without bolting, and which produce a flour of acceptable fineness for human consumption; other types of plates may require minor design modifications, and therefore plate availability, fastening and sizing should be checked out before production of this module and these components.

Remove one or both plates from the machine when other tasks such as threshing are being done since running dry results in rapid plate wear. Undoing the nut and locknut at the end of the layshaft allows this plate removal.

[Home](#)"" """"> [ar.cn.de.en.es.fr.id.it.ph.po.ru.sw](#)

[Index.htm](#) [Thr160.htm](#)

POWER PRODUCTION AND TRANSMISSION DESIGN ADOPTED

The power production and transmission parts are integral with the thresher (rightly or wrongly!). 4 pedallers sit upright in rectangular layout, pedalling 2 crankshafts located in 4 ball

bearings. Each crankshaft has a 44 tooth sprocket which drives its own 18 tooth sprocket on the layshaft, which runs in 2 ball bearings. These sprockets are standard bicycle units. A 44 tooth sprocket on the other end of the layshaft then drives via a bicycle chain to the 18 tooth sprocket on the thresher shaft.

Each pedaller sits in conventional bicycle fashion on a wooden or sprung leather saddle on a height-adjustable pillar, gripping 'handlebars' which are height-adjustable on 4 slanting pillars. The outer pedals can be of conventional bicycle type (or can be wooden pedals), but the inner 'pedals' are of split polyethylene tubing, within which the 25mm diameter pedal spindles rotate.

Note that many variations of this design are possible - with varying mechanical efficiency advantages, wear reduction advantages, and cost disadvantages.

The whole machine is supported on 3 short legs, and the largely 2-dimensional layout simplifies production by facilitating before and while electric arc welding of the frame takes place. All bearing housings have generous slots which facilitate sprocket alignment and chain tensioning. Incidentally, to ensure correct bearing alignment for the 2 crankshafts, the following procedure should be observed: complete all lathe operations on the crankshaft, then weld on the 2 inner cranks and the inner pedal spindles; only after cooling should the redundant section of the crankshaft be cut out by means of a hacksaw or power hacksaw.

The 2 outer 'left-hand' cranks (which are in fact driven by the right feet of 2 of the pedallers)

and the 2 outer 'right-hand' cranks and chainwheels can be driven on to their respective shafts, lined up, and lightly welded in place. Alternatively, flats may be produced beforehand, by skilled workmen using steel rule, hacksaw and flat file, for the fitting of standard bicycle cotter-pins. Or the flats can be produced by milling machine or lathe with milling attachment if available. The light welding option is probably the lowest cost method, and dismantling can be done using a portable angle grinder on the welds. Quite honestly we haven't really thought through all the possibly required onsite maintenance and repair operations which may be required.

Similarly, to prevent theft, the bicycle pedal spindles can be 'spot' arc welded to their respective cranks.

Incidentally, costs can be reduced by changing the 4 conventional bicycle pedals to home-made wooden pedals running on lathe-turned mild steel pedal spindles of say 12 mm diameter. With a coefficient of friction of 0.15, then the total additional power loss would be about 3 watts per pedaller - not at all bad. Use wooden pedals with grip slots and which have been soaked or boiled in old engine oil to impregnate them. If possible use African Blackwood, East African Afrormosia or Msaraka as the timber (also known as Dalbergia Melanoxylon, Mpingo, Spirostachys Africana, Muvanga and Afrormosia Angolensis) - see my report on Materials for Wooden Bearings, Lubrication Techniques and Wear Characteristics .

The total machine weight, with wooden beaters, is 115 kg, and overall dimensions are approximately 2.2 metres square x 1.2 metres high.

[Home](#) > [ar.cn.de.en.es.fr.id.it.ph.po.ru.sw](#)

[Index.htm](#) [Thr170.htm](#)

PRODUCTION TECHNIQUES

The machine described in this report is rather too complex to be produced by 'Village Technology' techniques as exemplified by McPherson (1976) or by VITA (1978). However TAMTU (1975) did instigate a system for the production of ox-powered equipment whereby high-accuracy parts and turned components were produced at the Central Workshop for sale to the Rural Craft Workshops, which performed the other skilled and the semi-skilled production and assembly tasks. This 2-stage or 2-level approach should work for the thresher and for many other pieces of equipment.

[Home](#) > [ar.cn.de.en.es.fr.id.it.ph.po.ru.sw](#)

[Index.htm](#) [Thr180.htm](#)

CAPITAL EQUIPMENT FOR THRESHER PRODUCTION

Items 1-3 are essential, 4-9 are 'nice to have'

1.	Electric Arc Welder. a.c. transformer tvpe. 130 amp	US\$ 750
----	---	----------

1.	Electric hand saw, 13mm capacity	US\$ 125
2.	Portable electric drill, 13mm capacity	US\$ 125
3.	Centre Lathe, 30mm headstock capacity	US\$ 5000
4.	Power Hacksaw	US\$ 3000
5.	Lathe Milling Attachment for slots and keyways	US\$ 250
6.	Milling Machine	US\$ 5000
7.	Pillar Drill 38mm capacity	US\$ 4000
8.	Wood-cutting circular saw	US\$ 1250
9.	Power wood planing equipment	US\$ 2500

Also tools like tapes, steel rules, vernier calipers, chisels, hammers, drill bits, pop rivet guns, hacksaws, files, spanners etc are required.

[Home](#) > [ar.cn.de.en.es.fr.id.it.ph.po.ru.sw](#)

[Index.htm](#) [Thr190.htm](#)

PRODUCTION COSTINGS (ESTIMATE)

Steel cost 100 kg @ US\$ 1250 / tonne	US\$ 125
Ball bearings, 9 pieces	US\$ 110
Cycle components, excluding saddles	US\$ 75
Milling plates, 2 pieces	US\$ 15
Labour cost, 40 man-hours @ US\$ 1.25 / hour	US\$ 50
Bolts, electrodes, electricity etc	US\$ 25
Subtotal	US\$ 400
Overheads and margins @ 30%	US\$ 120
Total Costs	US\$ 520

[Home](#) > [ar.cn.de.en.es.fr.id.it.ph.po.ru.sw](#)

[Index.htm](#) [Thr200.htm](#)

PREDICTED OUTPUT LEVELS

Let us assume that 0.6 kWh of mechanical energy per operator per day is available, and that specific energy for threshing of sorghum is 3.2 kWh/tonne. Therefore the thresher should be able to thresh 750 kg per day with 6 men operating.

If we assume 30 days threshing at the end of the growing season, then thresher output can be 22.5 tonnes per growing season (assuming single shift operation only). That corresponds to the output from 45 hectares with yields of 500 kg per hectare per growing season, or 22.5 hectare for 1000 kg per hectare yield.

Incidentally, average cereal consumption in societies where cereals are the staple food, and are not used in significant quantities for conversion to animal protein, is in the region of 200 kg per adult per year, providing an average daily food energy intake of 2055 kilocalories (2.4 kWh) per adult on a zero-loss basis.

Thus as an indication, one thresher could serve, on the basis of one growing season per year, a community whose number was around 110 adult equivalents, assuming that sorghum or millet was their only staple, and that no trade was conducted in that crop.

For Milling, from Omar (1977) and from standard milling textbooks, then 25 kWh / tonne is a reasonable figure for the production of fine flour from low moisture content maize, sorghum or millet. If we assume that 4 pedallers can produce 0.6 kWh per pedaller per day and that

milling can be done 320 days per year, then one machine could mill 30.7 tonnes of fine flour per year, serving a community of 154 adult equivalents.

[Home](#) > [ar.cn.de.en.es.fr.id.it.ph.po.ru.sw](#)

[Index.htm](#) [Thr210.htm](#)

OPERATIONAL COSTINGS

Using a net labor productivity improvement factor of 1.37 (over manual or traditional techniques) the thresher should 'save' 0.37 man-days per operator-day for 6 operators for up to 30 days per growing season per year.

Using a net labor productivity improvement factor of 1.3 to 1.7 (over manual or traditional techniques) the mill should 'save' 0.3 to 0.7 man-days or women-days per operator-day for 4 operators for up to 320 effective days per year.

If we price labor at US\$ 1 per man-day then the thresher can 'save' US\$ 66 per growing season, compared with its cost of US\$ 520 - not actually very impressive.... and taking 8 years to pay itself off if a zero rate of interest can be levied (an unlikely situation).

The mill can 'save' US\$ 400 to US\$ 900 per year, disregarding plate replacement costs (unknown or unresearched) and maintenance or repair costs - a much more impressive sum.

Coming from another angle, compare the thresher cost with the value of the grain which can be processed - 22.5 tonnes per growing season (and therefore probably per year) - @ US\$ 0.100 per kg is US\$ 2250 grain value per year; @US\$ 0.200 per kg is US\$ 4500 grain value per year. Compare with a machine cost of US\$ 520 and a probable effective thresher lifetime of 5 to 20 years - and it doesnt look too bad. If it were possible to extend threshed quantity by working 12 to 24 hours per day instead of 6-8 by using 12 to 24 operators working in rotas, then the economics would look better.

Coming from a 3rd angle, for milling compare with a commercial costing of US\$ 0.040 per kg milled. If one can mill 40 kg per operator per day (1 kWh mechanical energy per operator per day) then that corresponds to US\$ 1.60 per operator per day value added, giving US\$ 0.60 per operator per day available to amortise the mill and drive mechanism. Amortisation would take about 200 days, or 8 months to pay off the complete machine (including thresher).

[Home](#) > [ar.cn.de.en.es.fr.id.it.ph.po.ru.sw](#)

[Index.htm](#) [Thr220.htm](#)

MATERIAL REQUIREMENT

4.2 m x 75 x 50 x 2 mm MS RHS	2 crankshaft support frame members
-------------------------------	------------------------------------

15m x 50 x 50 x 1.8mm MS RHS	Other frame members, saddle columns and handlebar columns
4.4m x 40 x 40 x 1.8mm MS RHS	Minor frame members around threshing drum and saddle supports
0.3m x 60 x 60 x 2mm MS RHS	Handlebar brackets
2.8m x 25mm diameter MS Round Bar	Drum shaft and crankshafts
0.6m x 35mm diameter MS Round Bar	Layshaft
5m x 16mm diameter MS Round Bar	12 spokes for threshing drum
0.028m x 150mm dia MS Round Bar	Hub for Alternative spokes
0.11m x 75mm dia MS Round Bar	Milling plate locating flanges
0.06m x 55mm dia MS Round Bar	Sprocket bushes
1.5m x 30 x 30 x 3mm MS Angle	Saddle supports
0.3m x 150 x 10mm MS flat bar	Spoke hubs

0.27m x 150 x 25mm MS Flat Bar	Body, bearing housings
1.5m x 50 x 4mm MS Flat Bar	Brackets, bearing housings
1m x 30 x 4mm MS Flat Bar	Leg bracings/ reinforcements
6m x 50 x 8mm MS Flat Bar	Alternative high inertia steel beaters
2.4m x 21mm bore galvanised steel water pipe (GSP)	Handlebars
0.06m x 40mm bore GSP	Grain feed tube
5 m ² x 0.45mm thick galvanised steel sheet	Covers for Threshing Drum
1m x 25mm nominal bore PE water pipe	Pedals, inner crankshafts
6m x 75 x 25mm hardwood	Standard beaters
6 ball bearings, 20mm bore (type 16004.2Z or 6004.2Z or 6204.2Z)	Bearings, thresher shaft plus 2 pedal crankshafts
1 ball bearing, 25mm bore	Layshaft, sprocket end
1 tapered roller bearing, 20mm	Plate relative location and axial

1 tapered roller bearing, 20mm bore x 52mm dia	Plate relative location and axial thrust absorbtion, milling unit
2 pairs complete cycle chainwheels, cranks and pedals (44 teeth)	
1 additional cycle chainwheel (44 teeth)	Layshaft
3 cycle rear sprockets (18 teeth)	
4 cycle chains plus joining links	
4 locally made wooden saddles or leather sprung cycle saddles	

[Home](#) > [ar.cn.de.en.es.fr.id.it.ph.po.ru.sw](#)

[Index.htm](#) [Thr230.htm](#)

ADDITIONAL TESTING AND EXTENSION

The original prototype on-man thresher with wooden bearings as discussed above was tried over several days in February 1974 on a University research plot. The machine described in detail in this report was not completed until the end of the 1978 main growing season, and thus no testing or extension has yet been actioned with this machine (as of 1978).

Rayner (1975) borrowed a commercial Indian-made treadle rice thresher for trial with sorghum growers near Gairo in Tanzania. He reported a positive reaction from those farmers, despite the thresher being largely ineffective for sorghum.

A tractor-PTO (power take off) driven thresher using plain wooden beaters and no concave was produced and used at Morogoro in 1975 for several weeks during the harvesting season. Seven people fed sorghum heads to the drum. The machine proved the general principle of the threshing mechanism and technique used on this pedal thresher.

At Ulaya Ujamaa Village near Kilosa Tanzania, Msimbira (1974) introduced a pedal water pump for irrigation of horticultural produce. This project was well received and well utilised, being greatly preferred over using buckets and watering cans.

De Vries (1975) and the writer modified a damaged hand-operated single-hole imported Indian maize sheller to one-man pedal operation for Kisingi Ujamaa Village, near Morogoro. This modification was also well received.

The writer in 1974 modified a complete 'Hunts Minimill' grain mill from hand operation to one-man pedal operation, and loaned the mill to Lukobe Ujamaa Village, near Morogoro. The machine was however not found acceptable, due to its high torque requirement and lack of a flywheel.

[Home](#)"" """"> [ar.cn.de.en.es.fr.id.it.ph.po.ru.sw](#)

[Index.htm](#) [Thr240.htm](#)

CONCLUSIONS

It is difficult to make proper conclusions without extensive mechanical, field testing, and user acceptability testing.

The machine described in this report will effectively thresh sorghum and millets, and should also thresh wheat. It is probably not good at threshing beans (stupidly we never tried, but beans normally requires a peg type mechanism) and almost certainly no use for rice (which normal requires a wire hoop mechanism). Maybe this design can be adapted to provide all 3 types of drums or beaters.

The machine will also mill grain to various degrees of fineness, down to 2.4 modulus if the plates are not too worn.

The labor productivity of people operating the machine is expected to be about 1.4 times that of traditional methods, for threshing and for milling.

The machine should pay for itself within a reasonable time period (depending on utilisation of course - checkout the section Operational Costings above).

The machine could be adapted for engine power but is not really designed for such.

The machine is not suited completely for production by 'village technology' methods, since some components require middle levels of technical equipment and skill, but could be manufactured by a 2 level process as discussed above.

[Home](#) > [ar.cn.de.en.es.fr.id.it.ph.po.ru.sw](#)

[Index.htm](#) [Thr250.htm](#)

RECOMMENDATIONS

Do village or smallholder trials

Consider driving this kind of threshing mechanism by the same diesel or petrol engine used for hammer milling, when such exists.

Consider using the pedal mechanism for other equipment (such as winnowers, water pumps, maize shellers, etc..)

[Home](#)"" """"> [ar.cn.de.en.es.fr.id.it.ph.po.ru.sw](#)

[Index.htm](#) [Thr260.htm](#)

REFERENCES

ALVAN BLANCH (1976) - Threshers for Rice, Beans, Sorghum, and similar grain crops, promotional leaflet, published Alvan Blanch Ltd, Chelworth, UK

ARNOLD, R.E. and Lake, J.R. (1974) - Experiments with Rasp Bar Threshing Drums - Power Requirements, J. Inst.Agric Eng. Vol 9(4) pps 348-355

CADU (1976) - 'The Chilalu Agric Dev Unit Non-Cleaning Thresher' in 'Notes from the AT Unit' Vol 1(2) pub. Christian Relief and Development Association Box 5674, Addis Ababa

DE VRIES (1975) - Lecturer Univ Dar es Salaam Morogoro Tanzania - routine extension work.

EATON SUPERPLASTICS - 18 Freeman Street, Birmingham 5, UK - suppliers of flexible

connectible Vee-Belting.

GRAVES, R. (1962) Problems of a Man Powered Rotocraft - J.Royal Aero.Soc UK, 1962, 66, 707

HAYNES D.W.M. (1964) - 'Brief Review of Mechanisation Experiments in Northern Nigeria', mimeo, Papers of Agricultural Engineering in Northern Nigeria, quoted in Kline.

HOPFEN, H.J. (1960) - 'Farm Implements in Arid and Tropical Regions' pub UNFAO Rome (quoted in Kline)

HUNT Co Ltd, Earls Colne Colchester UK - manufacturers of agricultural equipment, including 'MiniMill' mills and plates.

INDIAN STANDARDS INSTITUTE (1965) - Indian Standard Specification for Paddy Thresher, Pedal Operated, IS:3327-1965

ISLAM, M.N. (1977) 'Harvesting, Conservation and Storage of Paddy Rice at Farm Level' Danish Royal Veterinary and Agricultural University, Institute of Agricultural Engineering, report # 32, p 23.

ITDG (1974) "A Hand powered thresher for Guinea Corn", ITDG London UK itdg@itdg.org

JAMANRE, T. (1970) -Treadle Thresher (mimeo) pub VITA USA . www.vita.org and vv@vita.org

JOHN DARBYSHIRE (1972) Photo Caption of Pedal Thresher in World Crops magazine
Sept/October 1972, p302

JOHNSON, L. , Casem, E.O. and Manalo. A.S. (1966) - 'Labor and Procedure for the Pedal
Thresher' - IRRI tech Paper # 2, Philippines.

KLINE, C.K., Green, DAG, Donahue, RL, and Stout, BA (1969) - Agricultural Mechanisation in
Equatorial Africa - Michigan State Univ Inst Int Agric, College Agric and Nat. Resources report #
6, pps 2.244 - 2.247

KRENDEL, E.S. (1963) "Man and Animal-Generated Power" in "Power Miscellany", pps 9.209
9.210.

KRENDEL, E.S. (1975) "Man as a Prime Mover" in "Machine Design" magazine, Trends in
Technology / Muscle Powered Flight, supplied VITA 1975

MCPHERSON, G. (1976) First Steps in Village Mechanisation pub. Tanzania Publishing House,
Dar es Salaam

MALAYA COLLEGE OF AGRICULTURE (1967) - Peanut Thresher - pub. ITDG London UK
itdg@itdg.org

MSIMBIRA, S.A.M. (1974) - "Testing of a Pedal Water Pump " 3rd year Student Special Project,

University of Dar es Salaam, Department of Agricultural Engineering, Morogoro, Tanzania.

OMAR, S.J. (1977) 'An Ergonomic Study of Human Powered Traditional and Modern Grain Milling Techniques' - 3rd year Student Special Project, University of Dar es Salaam, Department of Agricultural Engineering, Morogoro, Tanzania.

RAYNER, Kenelm (1975) - Oral Communication regarding his extension work for Morogoro Diocese, Anglican Church

RODALE (1978) - Pedal Power - pub Rodale Press USA

SHAMSANGA, K. (1975) - oral communication - University of Dar es Salaam, Department of Agricultural Engineering, Morogoro, Tanzania.

SHENSTONE, B.S. (1960) - Engineering Aspects in Man Powered Flight - J.Royal Aero Soc UK, 1960, 64, 471

SUGGS, C.W. (1970) - Soya Bean Thresher - dept Biology and Agric Engineering, N.Carolina State Univ - supplied VITA (mimeo)

SUTTON, D.H. (1969) 'Mini Thresher' UK Nat Inst Agric Engg, Overseas Liaison Unit Bulletin # 3, Silsoe, Bedfordshire UK

SUTTON, D.H. (1974) "A study of Human Energy Expenditure in the Winnowing Process", MSc Thesis, University of Reading, UK

TAMTU (1975) - Tanzania Agricultural Machinery Testing Unit, Ministry Agriculture, Box 1389, Arusha Tanzania. Engaged in the design and production of agricultural equipment

TROPICAL PRODUCTS INSTITUTE (1977) - demonstration of pedal hammer mill by Dr D Dendy (TPI London UK) at 'Rural Technology Meet', Arusha, September 1977, organised by Commonwealth Secretariat and Government of Tanzania

UNICEF - (1976) 4 man pedal centrifugal water pump demonstrated at Karen Village Technology Centre, during UNICEF conference 'Simple Technologies for the Rural Family', Nairobi, June 1976

VITA (1972) - "Portable Thresher" (mimeo) published Volunteers for International Technical Assistance, vv@vita.org www.vita.org Maryland USA

VITA (1975) - "Application of Human Muscle Power in Underdeveloped Countries" published Volunteers for International Technical Assistance, vv@vita.org www.vita.org Maryland USA Deep River Chapter (mimeo).

VITA (1977) - "Partial Listing of Manufacturers of Small Scale Threshers for Rice Cereals and other Crops" published Volunteers for International Technical Assistance, vv@vita.org

www.vita.org Maryland USA (mimeo).

VITA (1978) - "Village Technology Handbook " published Volunteers for International Technical Assistance, vv@vita.org www.vita.org Maryland USA

WILKIE, D.R. (1960) "Man as an Aero Engine", J.Roy.Aero.Soc., 1960, 64, 477

WILSON, S.S. (1971) - The Dynapod, Oxford Univ School of Engineering Science, Oxford UK (mimeo)

[Home](#)"" """"> [ar.cn.de.en.es.fr.id.it.ph.po.ru.sw](#)

[Index.htm](#) [Thr270.htm](#)

MISCELLANEOUS STRESS CALCULATIONS

Although the machine was largely designed from experience with the design and usage of similar equipment, some calculations are in order:

If 4 pedallers, each weighing 66 kg are seated in their positions then maximum bending moment in each crankshaft support frame member will be around 1050 Newton-metres. Taking the yield stress of mild steel as 2.10×10^8 Newton/metre squared, then 75 x 50 x 2mm mild steel rectangular hollow section should just yield under a bending moment of 2060

Newton-metre. Thus we have a safety factor of approximately 2.0 here.

Similarly, maximum bending moment in the front transverse frame member will be 230 N-m, whereas the section 50 x 50 x 1.8mm MS SHS should just yield under 1130 N-m.

It can be shown that the 15.88mm diameter stub axles for the pedal cranks should fail under torsional moment of 79 N-m, equivalent to a force of 43 kg force at the end of the crank. Normal operational torque loading should not exceed 30 N-m, equal to 150 Watts work rate at 48 rev/minute (5 radian/second).

Previous unpublished tests at Morogoro show that we need an axial force of about 1 tonne to produce 2.0 fineness modulus maize flour using the Hunts MiniMill Plates. The thread we are using is 25mm diameter metric fine, with major diameter 24.65 mm and minor diameter 22.5mm. 10000 Newtons axial thrust on one thread only has a safety factor of 1.7. Thus the layshaft thread, nut and locknut system should not be prone to failure.

Using a yield stress of 8×10^6 N/metre squared (in fact the value for GREEN hardwood), analysis of the wooden beaters gives a safety factor of 5 for shearing of the wood at the spoke nuts, and a safety factor of 1.3 for tensile stress failure due to bending at the middle of the beaters.

A similar analysis of the alternative mild steel beaters gives us a safety factor of 1.3.

[Index.htm](#) [Thr280.htm](#)

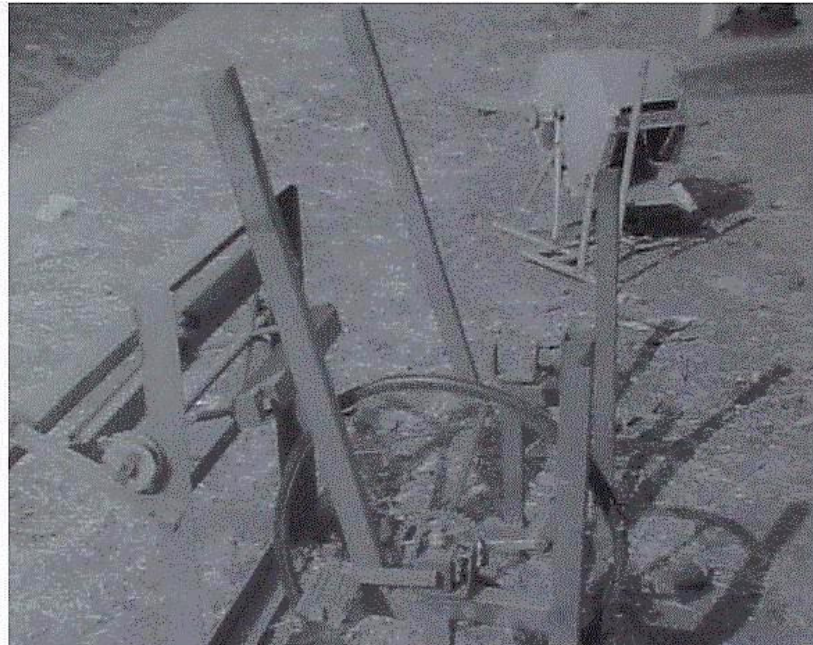



EARLY DESIGNS - A 2 MAN PEDAL THRESHER, BELT DRIVEN, WITH WOODEN BEARINGS. THE ORIGINAL DESIGN IS IN THE BACKGROUND - IT WAS COUPLED TO A ONE-MAN PEDAL UNIT WHOSE FRAME WAS LARGELY MADE FROM STEEL WATER PIPE (NOT SHOWN HERE)

[Home](#) > [ar.cn.de.en.es.fr.id.it.ph.po.ru.sw](#)

[Index.htm](#) [Thr290.htm](#)

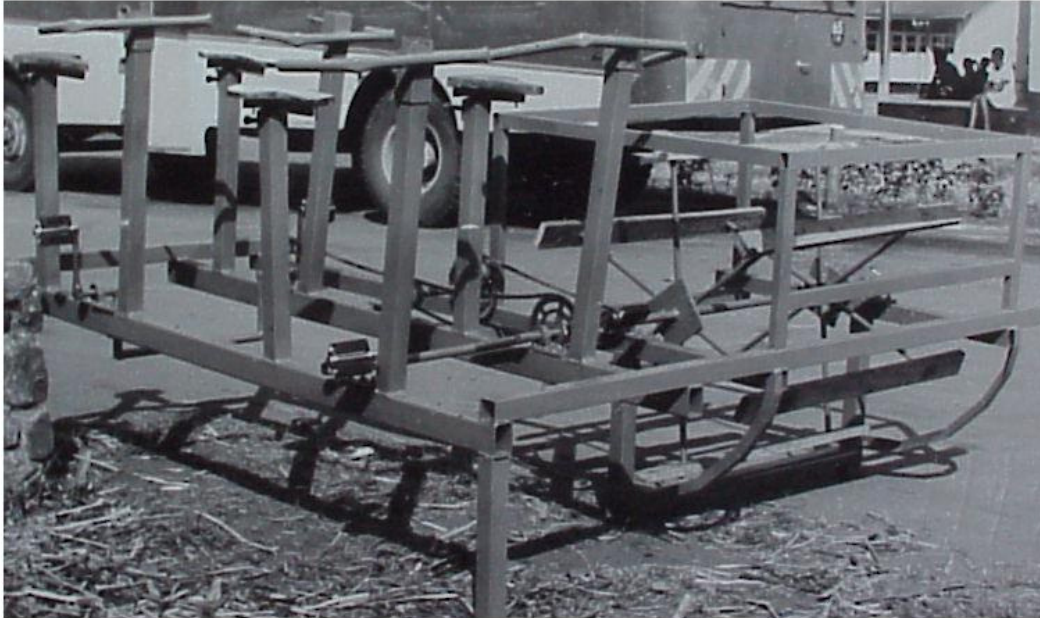

THE 4 MAN PEDAL THRESHER / MILL - WITHOUT MILLING UNIT AND ALSO WITHOUT SHEET METAL COVERS FOR THE THRESHING DRUM

[Home](#) > [ar](#).[cn](#).[de](#).[en](#).[es](#).[fr](#).[id](#).[it](#).[ph](#).[po](#).[ru](#).[sw](#)

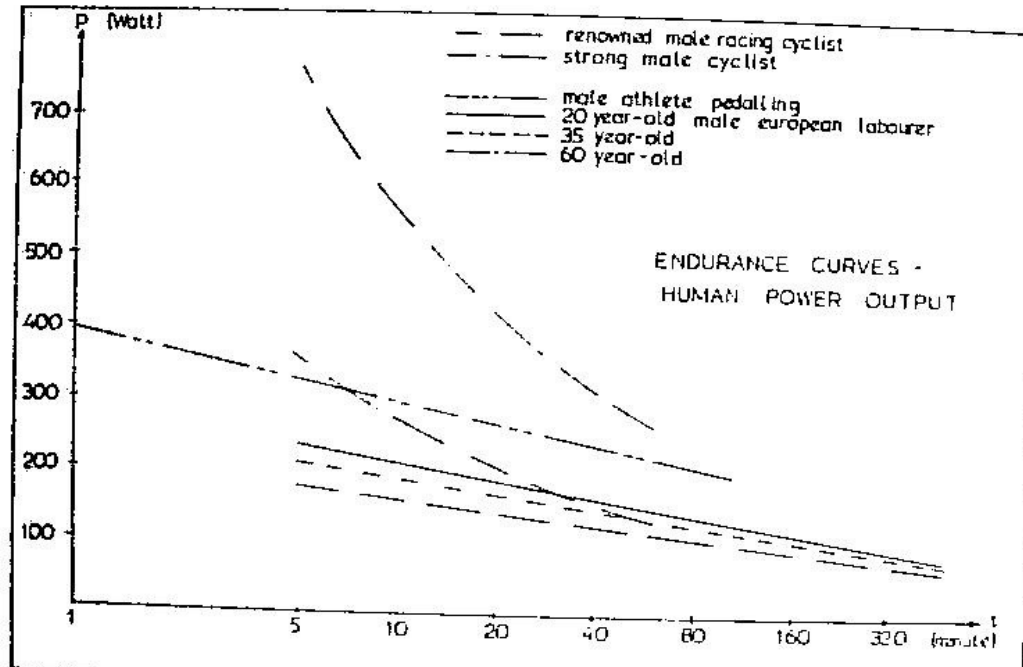
[Index.htm Thr310.htm](#)

[Home](#) > [ar](#).[cn](#).[de](#).[en](#).[es](#).[fr](#).[id](#).[it](#).[ph](#).[po](#).[ru](#).[sw](#)

[Index.htm](#) [Thr320.htm](#)

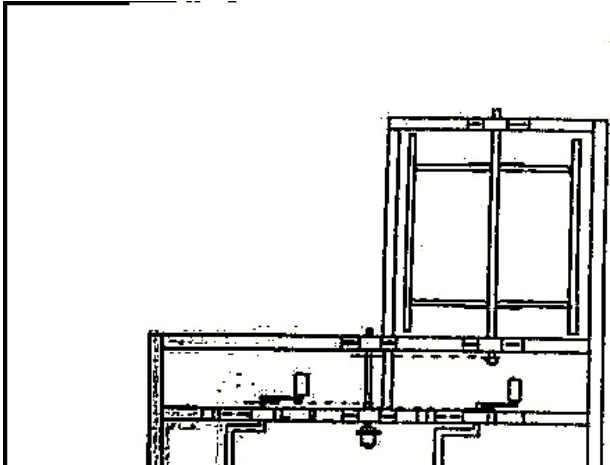

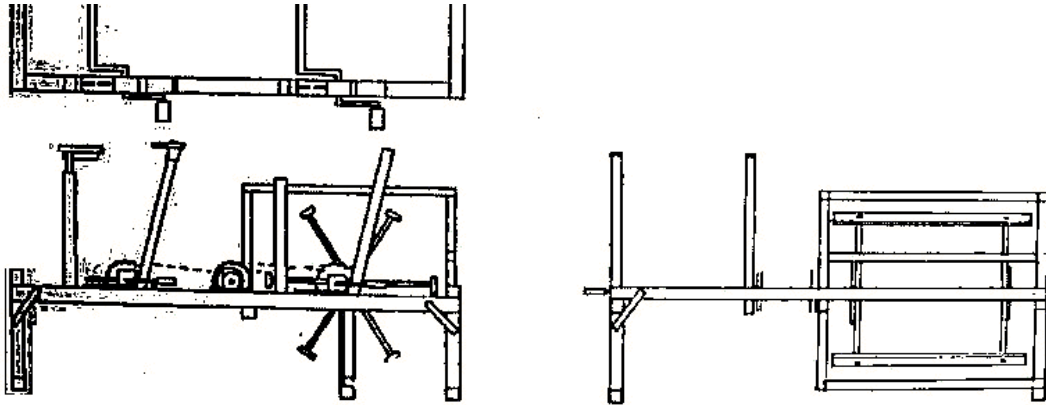

PEDAL THRESHER - MILL - ASSEMBLY

[Home](#) > [ar](#).[cn](#).[de](#).[en](#).[es](#).[fr](#).[id](#).[it](#).[ph](#).[po](#).[ru](#).[sw](#)

[Index.htm](#) [Thr330.htm](#)

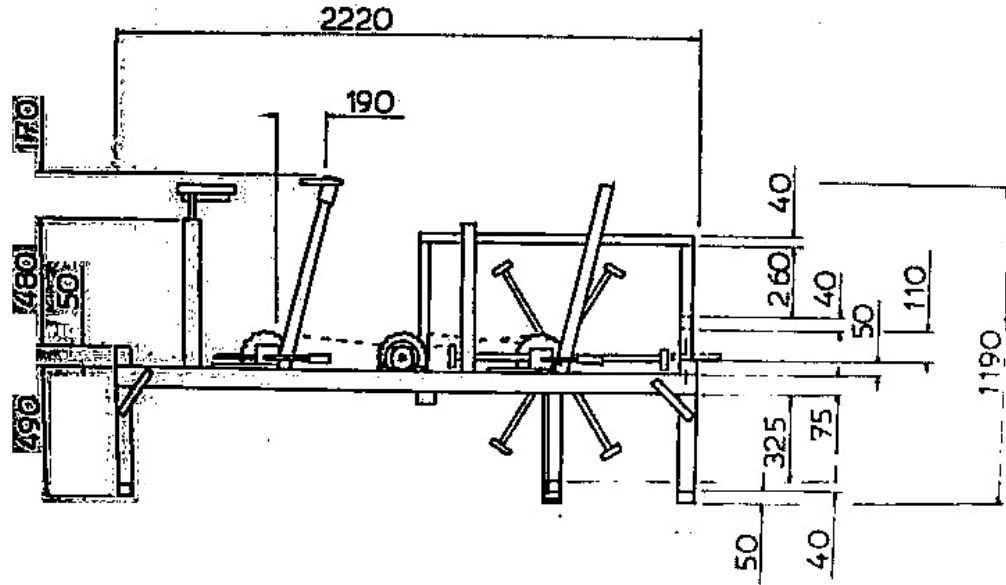

PEDAL THRESHER / MILL - ASSEMBLY

[Home](#) > [ar.cn.de.en.es.fr.id.it.ph.po.ru.sw](#)

[Index.htm](#) [Thr340.htm](#)

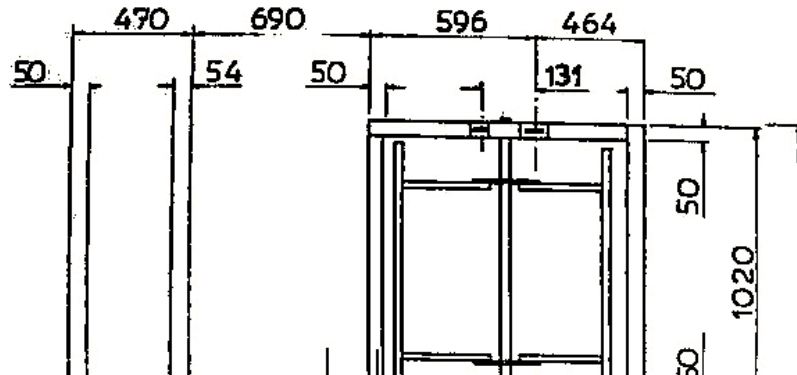

20/10/2011

PEDAL THRESHER and Grain Mill - dra...

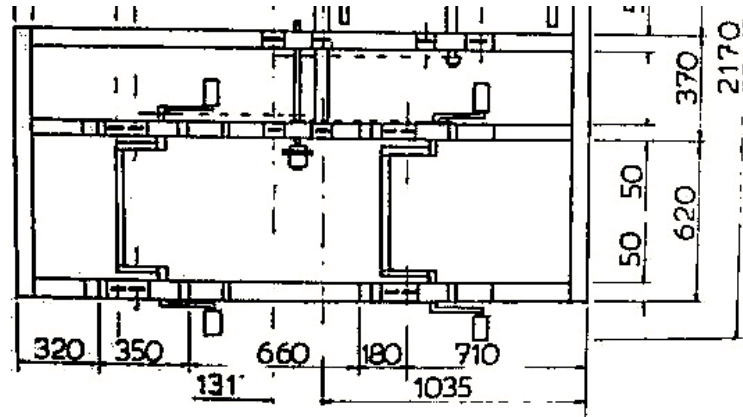

PEDAL THRESHER / MILL - ASSEMBLY

[Home](#) > [ar](#).[cn](#).[de](#).[en](#).[es](#).[fr](#).[id](#).[it](#).[ph](#).[po](#).[ru](#).[sw](#)

[Index.htm](#) [Thr350.htm](#)

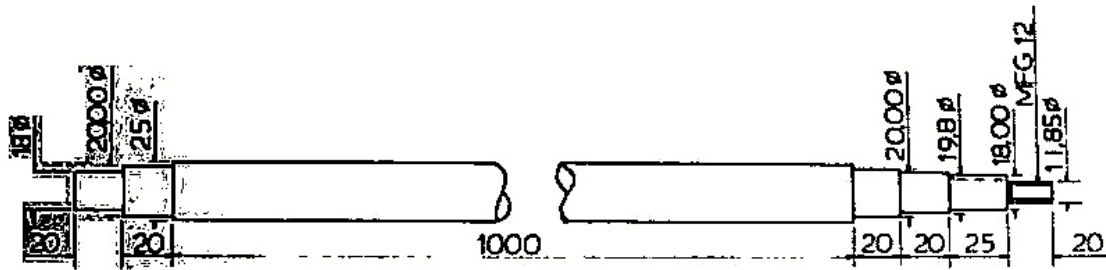

PEDAL THRESHER / MILL - DRUM SHAFT - 1 PIECE, MILD STEEL

[Home](#) > [ar.cn.de.en.es.fr.id.it.ph.po.ru.sw](#)

[Index.htm](#) [Thr360.htm](#)

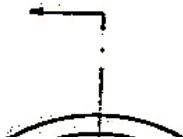

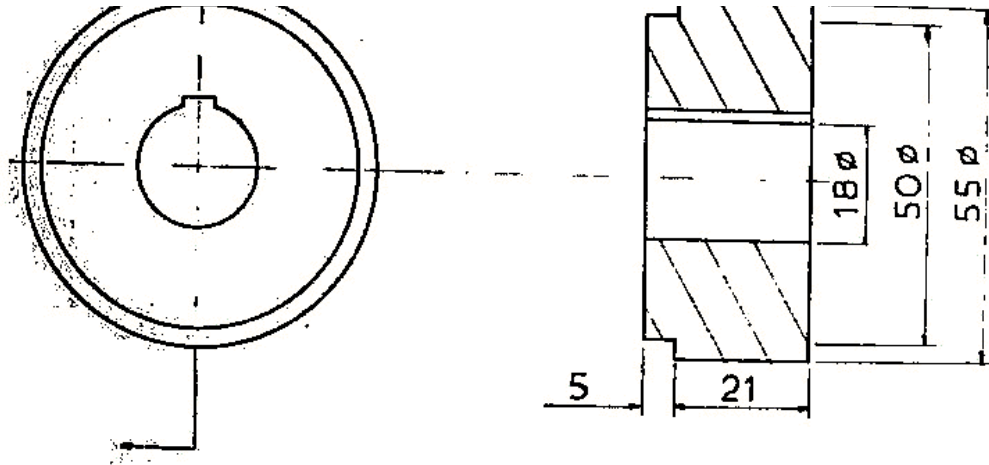

PEDAL THRESHER / MILL - DRUM SHAFT SPROCKET HUB, 1 PIECE, MILD STEEL

[Home](#) > [ar](#).[cn](#).[de](#).[en](#).[es](#).[fr](#).[id](#).[it](#).[ph](#).[po](#).[ru](#).[sw](#)

[Index.htm](#) [Thr370.htm](#)

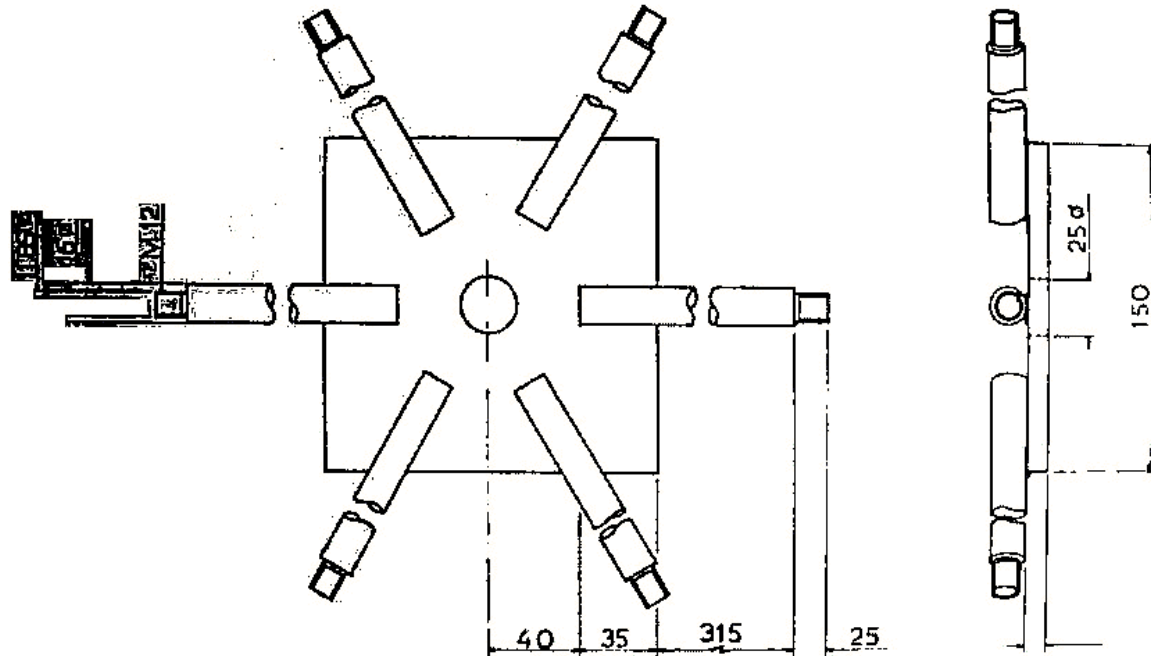

PEDAL THRESHER / MILL - SPOKE ASSEMBLY, NORMAL DESIGN, 2 PIECES, MILD STEEL, WITH 16MM DIAMETER SPOKES AND M12 THREAD (11,85MM MAJOR THREAD DIAMETER)

[Home](#) > [ar.cn.de.en.es.fr.id.it.ph.po.ru.sw](#)

[Index.htm](#) [Thr380.htm](#)

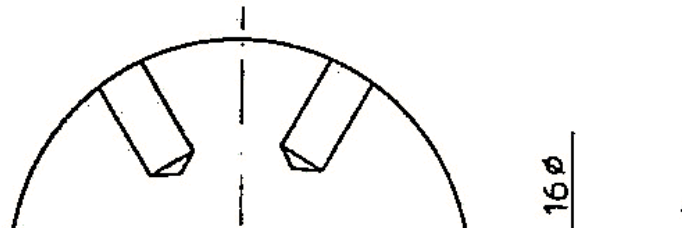

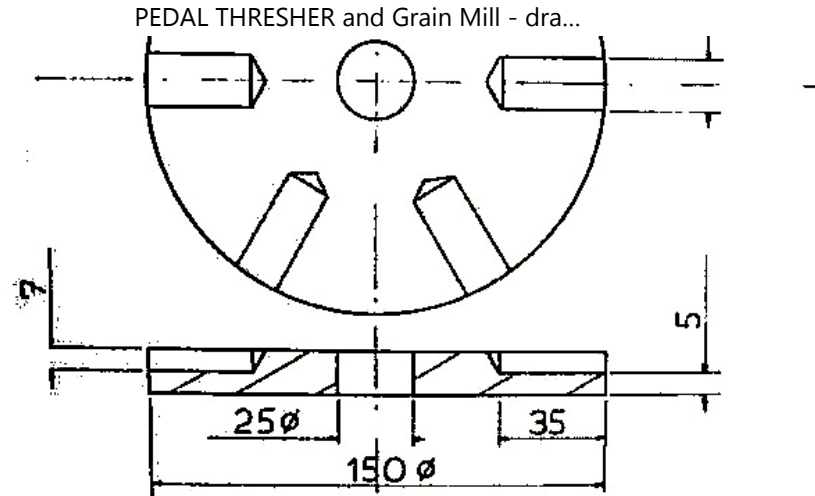

PEDAL THRESHER / MILL - SPOKE HUB, ALTERNATIVE DESIGN, 2 PIECES, MILD STEEL

[Home](#) > [ar.cn.de.en.es.fr.id.it.ph.po.ru.sw](#)

[Index.htm](#) [Thr390.htm](#)

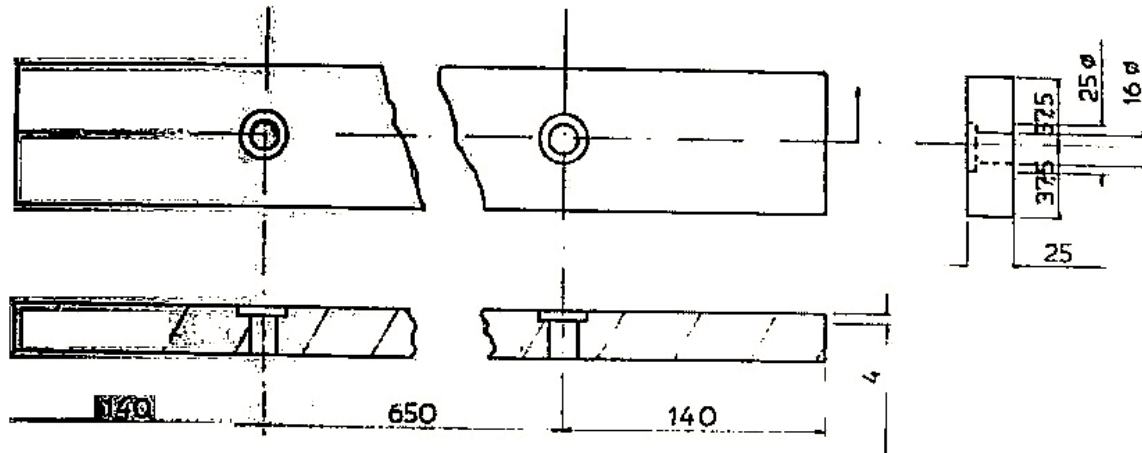

PEDAL THRESHER / MILL - BEATERS, NORMAL DESIGN, 6 PIECES, HARDWOOD

[Home](#) > [ar](#) [cn](#) [de](#) [en](#) [es](#) [fr](#) [id](#) [it](#) [ph](#) [po](#) [ru](#) [sw](#)

[Index.htm](#) [Thr400.htm](#)

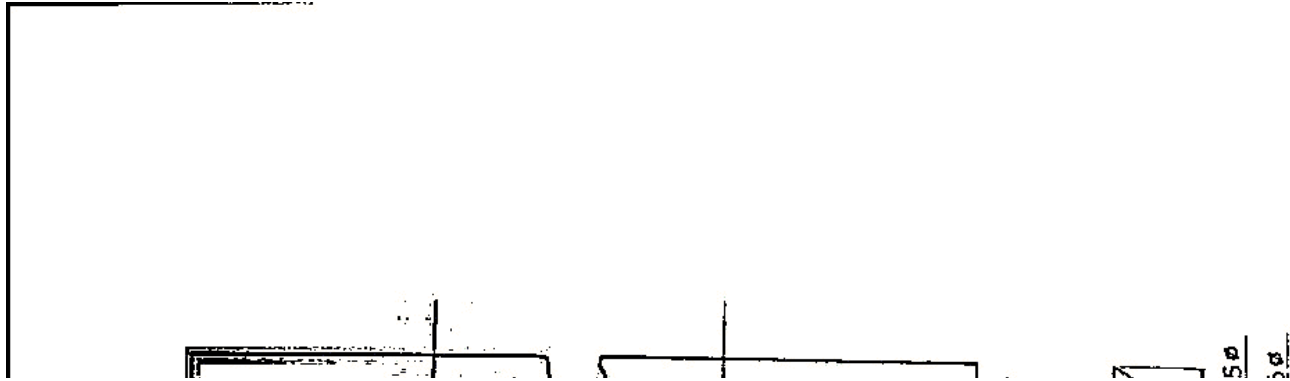

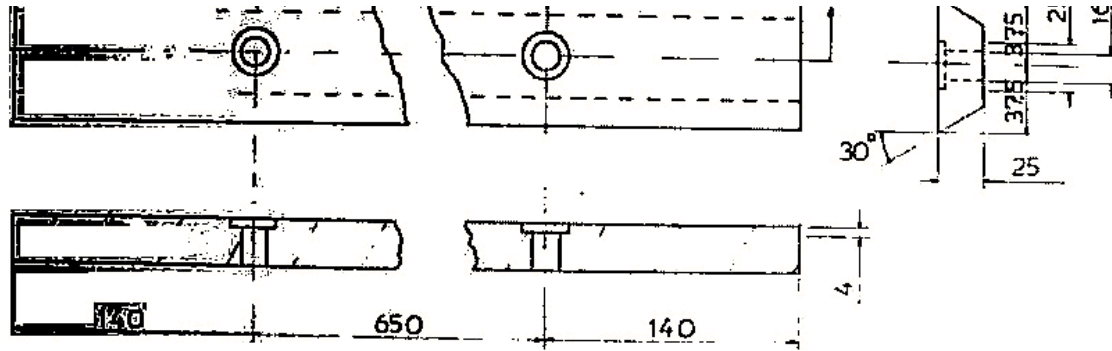

PEDAL THRESHER / MILL - BEATERS, ALTERNATIVE (AERODYNAMIC) DESIGN, 4 PIECES, HARDWOOD

[Home](#) > [ar](#) [cn](#) [de](#) [en](#) [es](#) [fr](#) [id](#) [it](#) [ph](#) [po](#) [ru](#) [sw](#)

[Index.htm Thr410.htm](#)

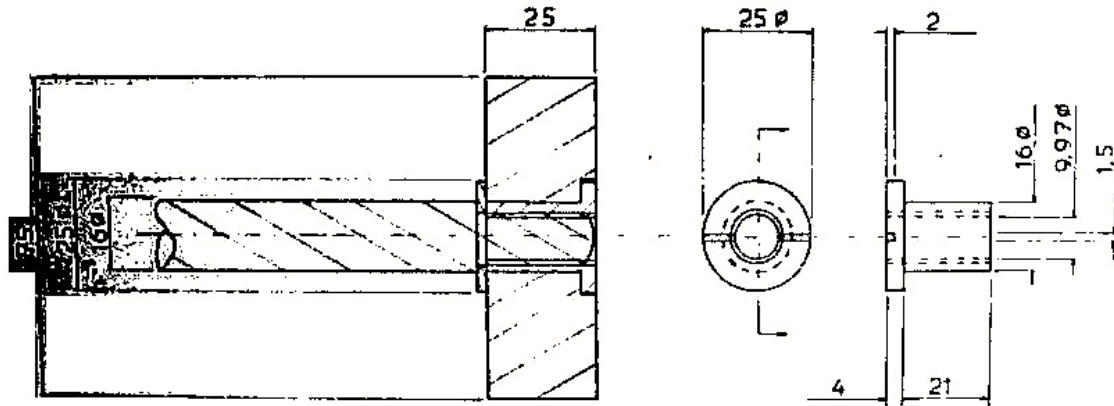

PEDAL THRESHER / MILL - BEATER/SPOKE NUTS, 12 PIECES, MILD STEEL

[Home](#) > [ar.cn.de.en.es.fr.id.it.ph.po.ru.sw](#)

[Index.htm](#) [Thr420.htm](#)



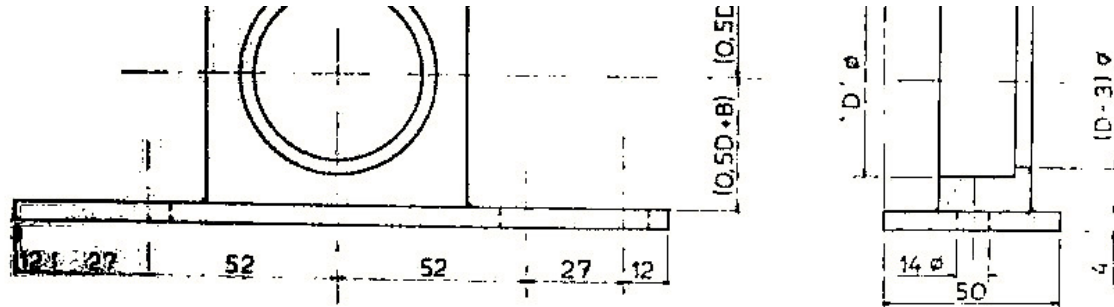

PEDAL THRESHER / MILL - BEARING HOUSING ASSEMBLY, 4 PIECES, MILD STEEL

[Index.htm](#) [Thr430.htm](#)

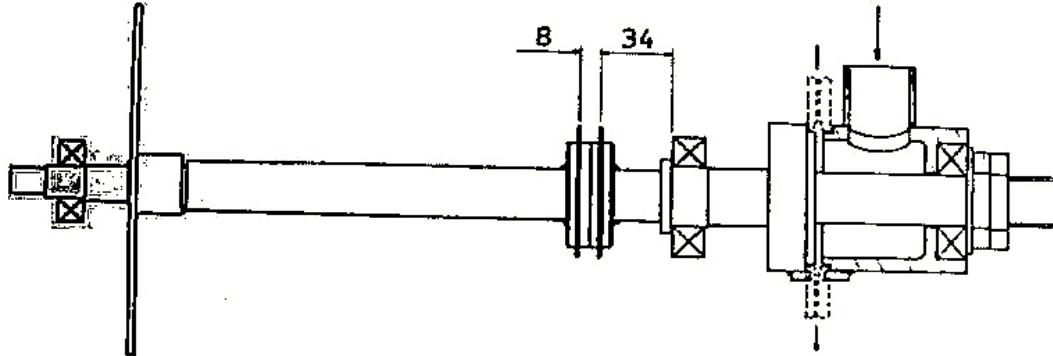

PEDAL THRESHER / MILL - LAYSHAFT ASSEMBLY, COMPLETE WITH SPROCKETS, BEARINGS AND MILLING UNIT (PLATES SHOWN AS DOTTED LINES)

[Home](#) > [ar.cn.de.en.es.fr.id.it.ph.po.ru.sw](#)

[Index.htm](#) [Thr440.htm](#)

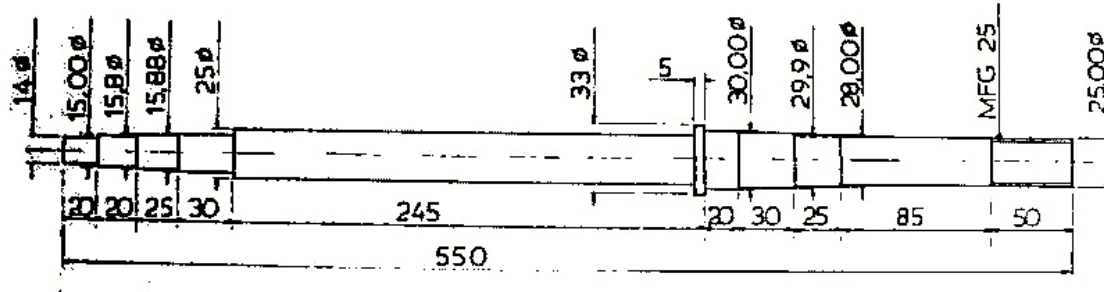

PEDAL THRESHER / MILL - LAYSHAFT, 1 PIECE, MILD STEEL

[Home](#) > [ar.cn.de.en.es.fr.id.it.ph.po.ru.sw](#)

[Index.htm](#) [Thr450.htm](#)

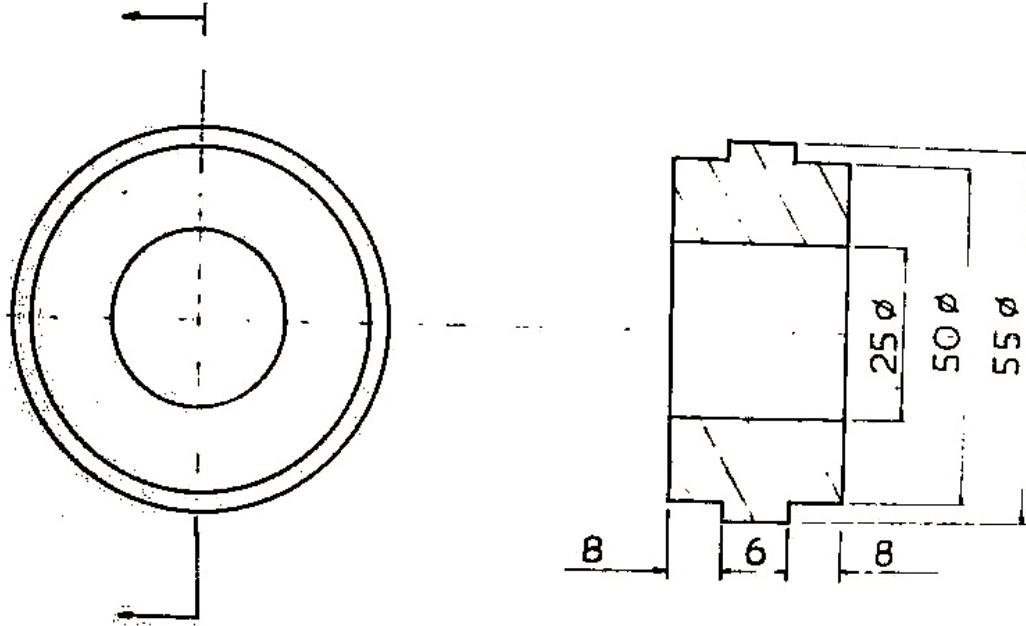

PEDAL THRESHER / MILL - LAYSHAFT TWIN-SPROCKET HUB, 1 PIECE, MILD STEEL

[Home](#) > [ar](#) [cn](#) [de](#) [en](#) [es](#) [fr](#) [id](#) [it](#) [ph](#) [po](#) [ru](#) [sw](#)

[Index.htm](#) [Thr460.htm](#)

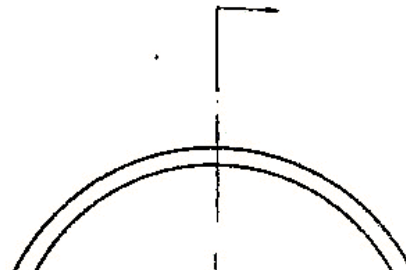

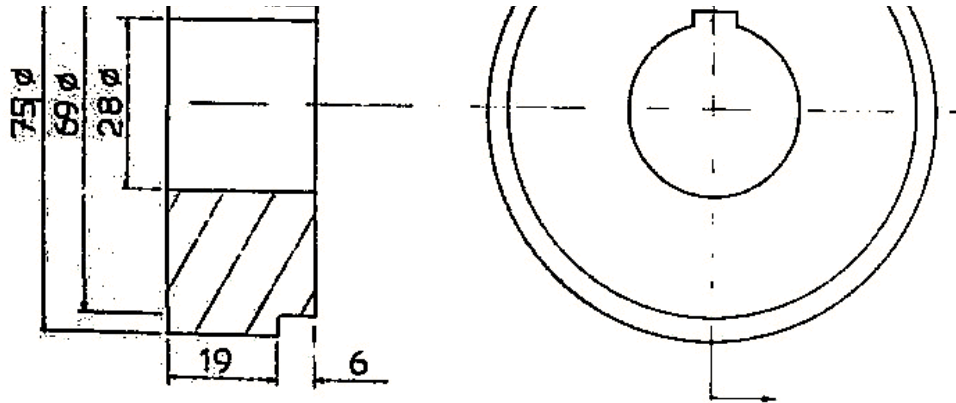

PEDAL THRESHER / MILL - ROTARY PLATE LOACTING FLANGE, 1 PIECE, MILD STEEL

[Home](#) > [ar.cn.de.en.es.fr.id.it.ph.po.ru.sw](#)

[Index.htm](#) [Thr470.htm](#)

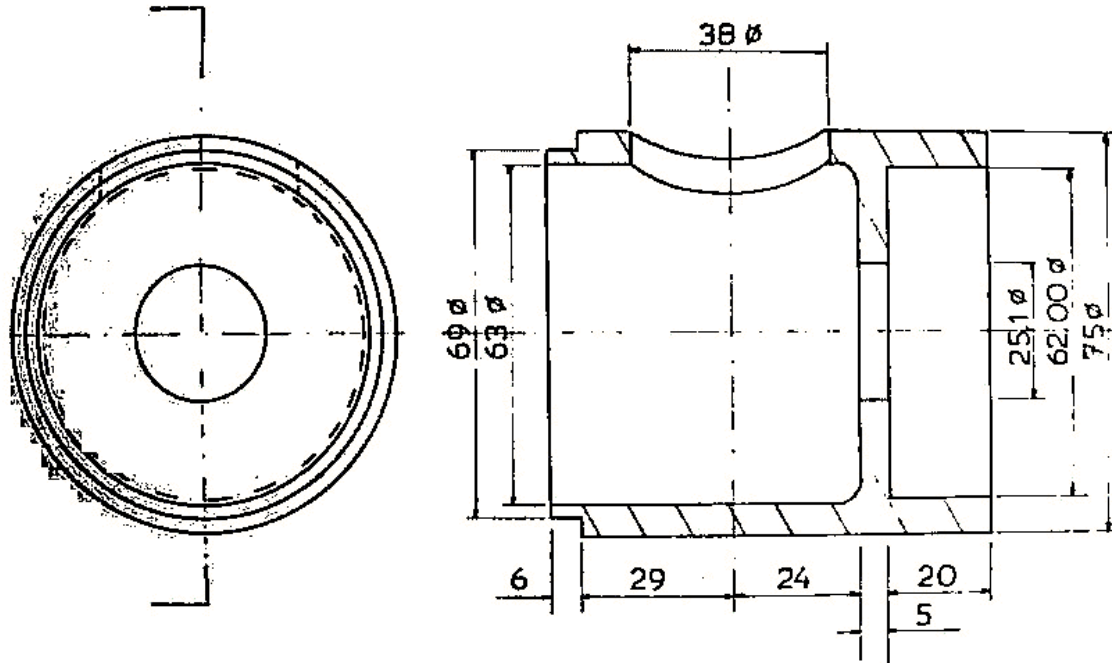

PEDAL THRESHER / MILL - STATIONARY PLATE LOCATING FLANGE, 1 PIECE, MILD STEEL

[Home](#) > [ar.cn.de.en.es.fr.id.it.ph.po.ru.sw](#)

[Index.htm](#) [Thr480.htm](#)

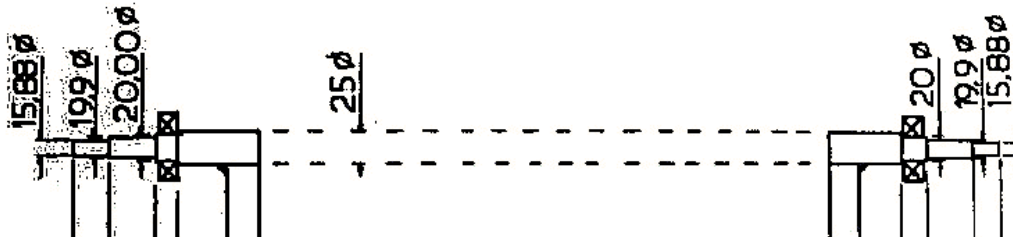

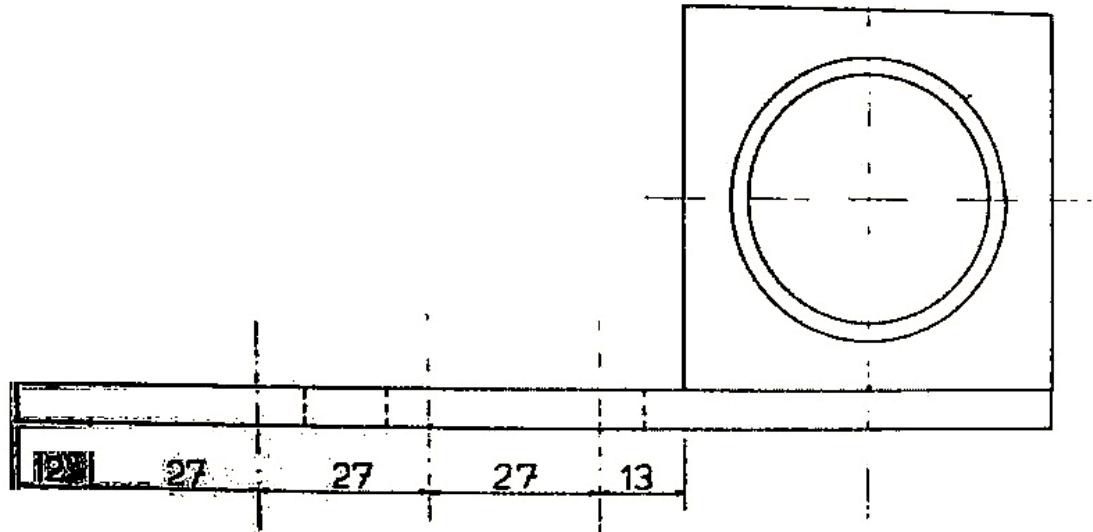

PEDAL THRESHER / MILL - CRANKSHAFT BEARING HOUSING ASSEMBLY, 4 PIECES, MILD STEEL

[Home](#) > [ar.cn.de.en.es.fr.id.it.ph.po.ru.sw](#)

[Index.htm](#) [Thr500.htm](#)

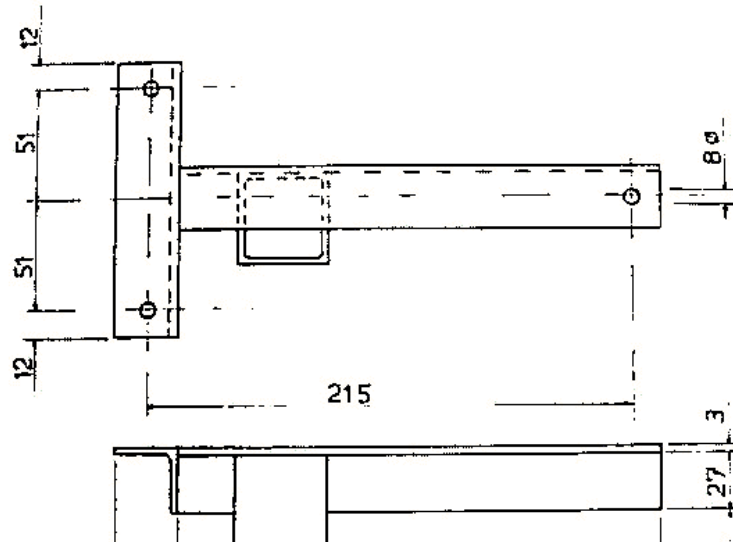

20/10/2011

PEDAL THRESHER and Grain Mill - dra...

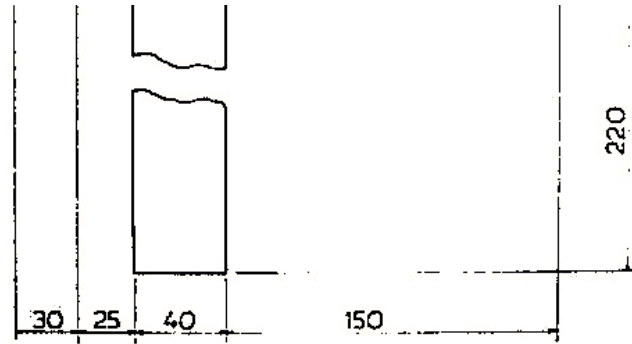

PEDAL THRESHER / MILL - HEIGHT ADJUSTABLE SADDLE SUPPORT ASSEMBLY, 4 PIECES, MILD STEEL

[Home](#) > [ar](#).[cn](#).[de](#).[en](#).[es](#).[fr](#).[id](#).[it](#).[ph](#).[po](#).[ru](#).[sw](#)

[Index.htm](#) [Thr510.htm](#)

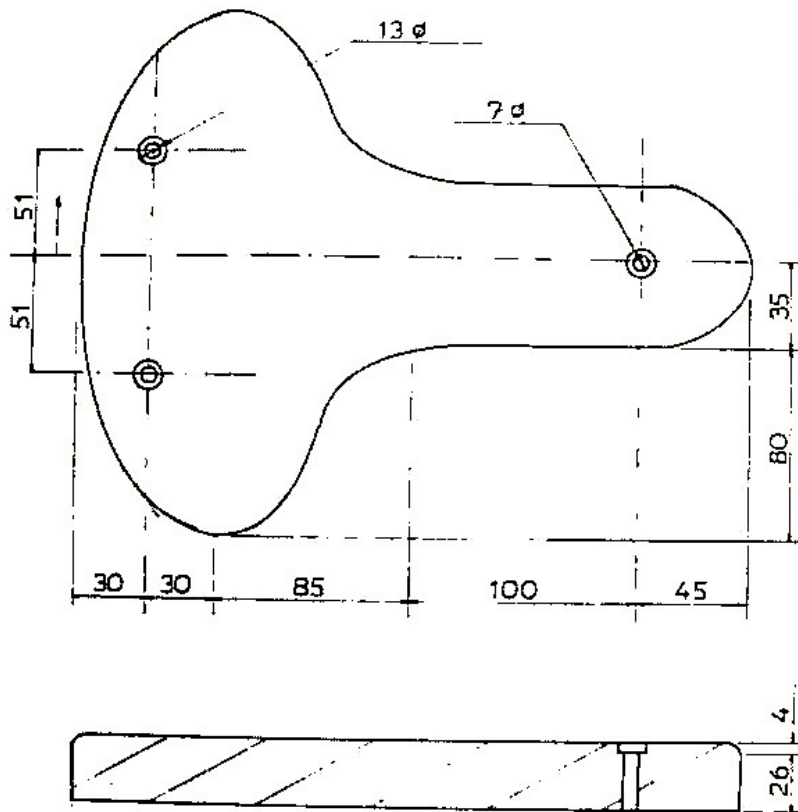

PEDAL THRESHER / MILL - SADDLE, 4 PIECES, HARDWOOD (WITHOUT PADDING)

[Home](#) > [ar](#).[cn](#).[de](#).[en](#).[es](#).[fr](#).[id](#).[it](#).[ph](#).[po](#).[ru](#).[sw](#)

[Index.htm](#)

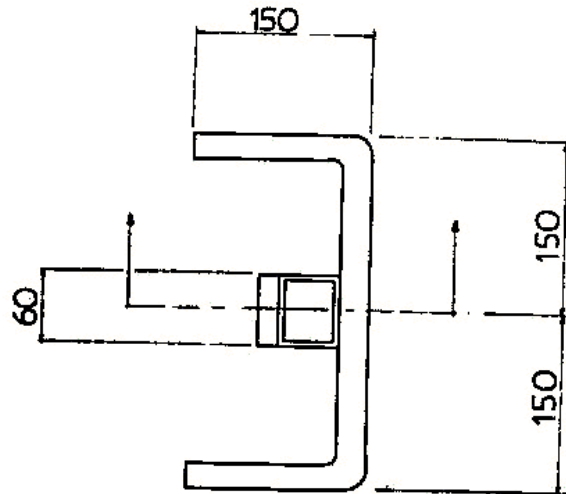

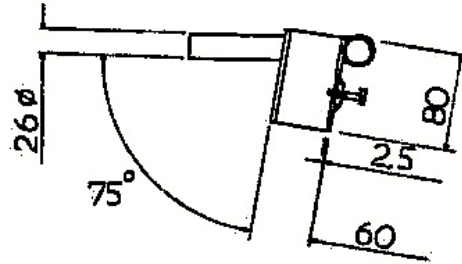

PEDAL THRESHER / MILL - HANDLEBAR ASEMBLY, HEIGHT-ADJUSTABLE, 4 PIECES, MILD STEEL