



# SOURCE BOOK

FOR TEACHING, LEARNING AND ENJOYING PHYSICS



# **SOURCE BOOK**

***IDEAS FOR TEACHING PHYSICS TO BEGINNERS  
WITH LOCALLY AVAILABLE MATERIALS***

***IDEAS FOR TEACHING, LEARNING AND ASSESSMENT BY DOING***



**MZUMBE BOOK PROJECT  
P.O. Box 19 MZUMBE,  
MOROGORO • TANZANIA**

This source book is the result of a workshop held at Morogoro Secondary School (Tanzania) from July 15th to 26th 1991. The workshop was organised by the Ministry of Education and Culture in cooperation with the Goethe-Institut (German Cultural Institute).

Workshop Administrative Coordinator:

Ignatius Sarikoki, Ministry of Education and Culture, Tanzania

Workshop Technical Coordinator:

Hans Schmidt, Darmstadt, Germany

Editing Coordinators:

J.B.A. Mihigo, Mzumbe Book/Project  
Manfred Schiess, Rastatt, Germany

This workshop project was sponsored by:

- Ministry of Education and Culture, Tanzania
- Ministry of Education and Culture, Hessen, Germany
- Goethe-Institut, Dar es Salaam

This low-priced edition for Tanzania is sponsored by:

- Canadian Organization For Development Through Education (CODE)
- Partnership Furtherance With the Third World (APDW), Karlsruhe, Germany

Editorial committee:

J.M. Waryoba, A.S. Mrutu, B.W. Faustine, M.J. Mbuji,  
J.M. Sekulu, J.B.A. Mihigo, G. Emmanuel, B. Enjiku,  
I. Tabaro, D. Pietz, M. Schiess

The editors thank Dr. W. Kemp, C. and G. Stieghorst for their valuable comments and help in proof-reading.

Special Technical assistance was sponsored by:

- German Didacta Association, Frankfurt, Germany (Deutscher Didacta Verband, e.V.)
- Merck Ltd., Darmstadt, Germany.

Type set by B.B. Sallim, Mrs. A. Mihigo

Graphic design by R. Kanyawana, C. Mdachi, P. Ndunguru

Darkroom technique: M. E. Mwano, Miss. E. Mwombeki

Production Supervisor: C. Mazunda

© Mzumbe Book Project 1991

ISBN 9987 552 11 0

Printed and Bound by

**Mzumbe Book Project**  
**P.O. Box 19 Mzumbe**  
**Morogoro - Tanzania**

**List of Participants:**

Alinanuswe W.P. Mwakabanje  
Loleza Secondary School

Daudi Mbungu  
Tambaza Secondary School

Busanji Wilson Faustine  
Kilakala Secondary School

Charles Philemon  
Jangwani Secondary School

T.J. Msami  
Weruweru Secondary School

M.J. Mbuji  
Minaki Secondary School

U.S. Mohamed  
Usagara Secondary School

J.D.K. Bulemo  
Azania Secondary School

Pastory B. Rwamwasi  
Pugu Secondary School

Bonus P. Ndimbo  
Songea Boys Secondary School

Raphael R. Malisa  
Old Moshi Secondary School

H. Mgonja  
Same Secondary School

Samwel N.J. Mwakasonda  
Tabora Boys Secondary School

Mrs M. Muyenge  
Mzumbe Secondary School

George Emmanuel  
Morogoro Secondary School

Detlef Pietz  
Iyego Secondary School, Murang'a, Kenya

Jones M. Waryoba  
Institute of Curriculum Development, Tanzania

J.M. Sekulu  
Kleruu Teachers Training College

Dr. Manfred Spohr  
Dar es Salaam Teachers Training College

A.S. Mrutu  
Ministry of Education

D.D. Ben Enjiku  
Institute of Teacher Education - Uganda

Ignatius Tabaro-Sinaruhamagaye  
National Curriculum Development Centre - Uganda

## Foreword

Children come to school with rich knowledge about their environment. They gained this knowledge through observation and imitation. For example, they know how to construct toy cars by perfectly applying the physical laws. They also know how to carry a heavy load on the head and how to lift a heavy stone. They can do all this without studying Physics. Through such learning by doing they absorb easily the knowledge needed to solve everyday problems.

Science and Physics for that matter is borne in the nature around us. Scientists observe, explain and formulate the results into abstract laws for further investigation of other problems. We are all born with the ability to be investigators, however, we have to learn how to do it. This learning should start with phenomena the child is familiar with and not with abstract definitions what science is.

The rich practical knowledge of the students can be used as a springboard for teaching science not only to beginners by getting the pupils to have a critical look at and ask analytical questions about their environment. This requires a practical approach in teaching. By this approach students learn to be investigators by finding the applied principles in the things around them. Students should learn to see the daily environment with the eyes of an analytical scientist. This makes them also aware of the resources to be found in their country.

Physics as a natural science deals with the investigation of matter. However, the investigation of matter can be done by using a practical approach only.

Children are eager to talk or ask questions about things they are familiar with rather than about abstract theoretical knowledge taken from books.

Furthermore, the teaching of science with locally available materials makes learning by doing accessible, even when conditions for teaching are not conducive.

This is the message of this book. It shows that the most common materials are often sufficient for stimulating experimental lessons. Experimenting is a difficult job for a less experienced teacher. However it can also be fun for him. Most of the experiments described in this book can be performed in a very short time and without long sessions of preparation.

The described experiments are not only for school purposes, but also for other people interested in this subject.

It is my sincere hope that this book will contribute to the building up of a broad line of people in our country who are interested in learning more about Physics.

LET US ENJOY PHYSICS BY DOING  
L.K. MSAKI  
Acting Commissioner for Education

## Preface

This source book is addressed to people who are concerned with teaching Science at the Junior Secondary School level. This includes Teachers, Teacher Training College Tutors and University Lecturers. Nevertheless, the book can be useful to Science Club Masters and Students who want to experiment on their own. The main audience are the teachers and tutors who work in inadequate teaching and learning conditions trying to encourage students to develop capabilities to master and use science in their daily life.

This source book contains therefore experiments and activities which can be performed in any classroom and in a very short time with a few low or even no cost materials. Moreover, these practicals do not require a long preparation time.

Such easy to carry out experiments for and through beginners have a long standing tradition in the history of teaching science. They are called *handy experiments* because they can be performed "by hands" only without any difficulties.

You will find in this source book ideas and suggestions which are not normally found in textbooks. We assume that the teachers know most of the traditional experiments which are found in the usual textbooks. Therefore there is no need to repeat them here. The reader will welcome the ideas on how to modernize his teaching since this book provides him not only with the "how to do it" but also with the "what to do" information.

Going through this book, the reader will find that many traditional experiments can be performed as handy experiments too. They are more illustrative and more appealing to students than "black box experiments" with sophisticated equipment. They encourage the students' creativity to invent other experiments and stimulate their natural curiosity to understand the physics behind the experiments.

The suggestions of this source book are stimulants to modern teaching and learning, i.e. *teaching and learning by doing*. They should be supplemented with the teachers' own ideas, students' ideas and ideas from other sources. This source book is a result of a workshop which drew participants from Uganda, Kenya, Germany and Tanzania.

We acknowledge with gratitude the professional, technical and financial assistance of all who have contributed to publish this source book particularly to the Ministry of Culture of the State of Hessen (Germany) and the Goethe-Institute for sponsoring the workshop.

Last but not least, we thank Morogoro Secondary School for hosting the workshop from which the source book resulted.

A.S. NDEKI  
Chairman of the Executive Committee  
Mzumbe Book Project

# Contents

Foreword.....	6
Preface.....	7
How to Use This Book .....	10
1. What is Physics?.....	12
2. Laboratory Techniques .....	18
2.1 Collection of Data .....	18
3. Basic Mechanics .....	27
3.1 Rectilinear Motion.....	27
3.2 Forces.....	28
3.3 Weight and Mass.....	33
3.4 Centre of Gravity and Stability.....	38
3.5 The Force of Friction .....	44
3.6 Density.....	48
3.7 Pressure in Liquids and Gases .....	49
3.8 Archimedes' Principle and the Law of Floatation .....	59
3.9 Work, Energy and Power .....	63
3.10 Simple Machines .....	68
3.11 Astronomy - The Solar System .....	73
4. Matter .....	78
4.1 The Particle Model of Matter .....	78
4.2 States of Matter .....	82
4.3 Motion of Particles.....	84
4.4 Cohesion and Adhesion .....	87
4.5 Elasticity and Viscosity .....	93
5. Thermal Physics.....	96
5.1 Thermal Energy and Temperature .....	96
5.1.3 Fixed Points .....	98
5.1.4 Specific Heat Capacity of Liquids .....	98
5.1.5 Thermal Energy .....	99
5.1.6 Application of Specific Heat Capacity.....	100
5.2 Thermal Expansion .....	100
5.2.1 Expansion Apparatus.....	101
5.2.2 A Simple Model for Explaining Expansion.....	101
5.2.3 Expansion of a Coin.....	102
5.2.4 Expansion of a Wire.....	102
5.2.5 Applied Expansion .....	103
5.2.6 Bimetal Principle .....	103
5.2.7 Expansion of a Liquid .....	104
5.2.8 Allowing for Liquid Expansion.....	104
5.2.9 The Jumping Coin.....	105
5.2.10 Contraction of Air .....	105
5.3 Changes of State.....	106
5.3.1 Changes of State of Water .....	106
5.3.2 Rain and Hailstone Formation .....	107
5.3.3 Evaporation.....	107
5.3.4 Evaporation.....	108
5.3.5 Cooling Water .....	108
5.3.6 The Refrigerator.....	109
5.3.7 Pressure and Melting Point.....	110
5.3.8 Impurities and Melting Point .....	110
5.3.9 Pressure and Boiling Point .....	111
5.3.10 The Pressure Cooker.....	111
5.4 Transfer of Thermal Energy .....	112
6. Wave Motion .....	119
6.1. Production of Waves .....	119
6.2 Propagation of Waves .....	125
6.3 Reflection of Waves .....	128
6.4 Music and Musical Instruments .....	132



7. Geometrical Optics .....	137
7.1 Nature and Propagation of Light .....	137
7.2 Reflection of Light.....	146
7.3 Refraction of Light .....	152
7.4 Lenses and Optical Instruments.....	156
7.5 Dispersion and Colours .....	166
8. Magnetism and Electricity .....	170
8.1 Magnetism.....	170
8.2 Electrostatics .....	177
8.3 Electric Current.....	182
Appendix .....	192
A Sootless Kerosene Burner .....	192
Test Tubes and Flasks .....	193
List of Materials .....	194
Questionnaire.....	200

## How to Use This Book

This source book may be used in connection with the series of textbooks called "Enjoy Physics", volume I and II, produced by the same publishers, the MZUMBE BOOK PROJECT. These books have been written with great emphasis on the use of materials which can easily be obtained from our environment. However, this source book may be also used without these textbooks.

Many students think that Physics is a very tough subject and they actually fear it. If you as a Physics teacher use the approach suggested in this source book, you can be quite sure that your students will lose their fear. They will become interested and creative in Physics. They will like and even enjoy your Physics lessons. This way they will be able to develop those talents which are needed for real development to take place.

Being a Physics teacher, this book will help you to master the simple techniques described in order to be able to make simple apparatus, models and other teaching aids. After this you may want to transfer the skills to your pupils so that they may help you in making the required items.

The experiments described in this book are simple and can be carried out even in the absence of a Physics laboratory. The Physics kit described in the appendix is meant to be self-contained. However, first you may select only a few experiments from each section. Therefore, we have listed the materials needed for each single experiment in the appendix. Of course, each kit needs all the *materials* listed on p.111 and these were omitted in the list of materials of the various experiments (see p.112).

Perhaps your students might become interested to prepare the materials for further experiments described in this source book. Thus, after some time you might be able to carry out most of the experiments suggested.

For heating purposes an improved, sootless kerosene burner has been developed which any "fundi", who makes normal "vibatari", is able to produce, see p. 109.

Being a Student, this book may also help you in the designing and carrying out of physics projects. If you produce your own Physics kit, this will provide you with a kind of minilab at home.

Using it, you can train yourself on the practical and investigating aspects of Physics. Therefore, you will enjoy Physics and develop your talents in this subject. This way, Physics may contribute to self-sustained development by improving the daily life of the people.

An experiment has several important phases which we have usually outlined in this source book. The symbols are as follows:

**P:** The *procedure*: what and how to perform the experiment and/or how to build the apparatus.

**Q:** *Questions* which the investigator may ask himself or a teacher may ask his students in order to guide them to the proper observations and explanations.

At this stage the dedicated investigator or student should stop reading and try to answer the questions himself after carrying out the experiment. If he/she has the self-discipline needed to do this, he/she will certainly gain a lot.

**O:** The *observations* are described here. So you may check *after* you have made your own observations if you did not miss an important point.

**E:** The *explanation* of the observations is outlined here. Physics always aims for explaining observations. Only if he can explain his observation, the scientist usually will be able to predict the outcome of other experiments. This leads to the knowledge of the laws of physics. Then he/she may also become creative enough to apply a certain physical law in a machine or an apparatus which he/she invents. This way development takes place.

**A:** Some *applications* of the phenomenon under investigation in the respective experiment may be given here. Thus, the interested student will easily recognise and appreciate the close relationship between Physics and Technology. The latter cannot exist without the former.

We warmly welcome your criticism, suggestions and opinions about this book. Please, fill in the questionnaire at the end of this volume and send it to us. Please write to us to improve future editions of this book:

Team of the source book and "Enjoy Physics"

Mzumbe Book Project  
P.O. Box 19,  
Mzumbe - Morogoro  
Tanzania.

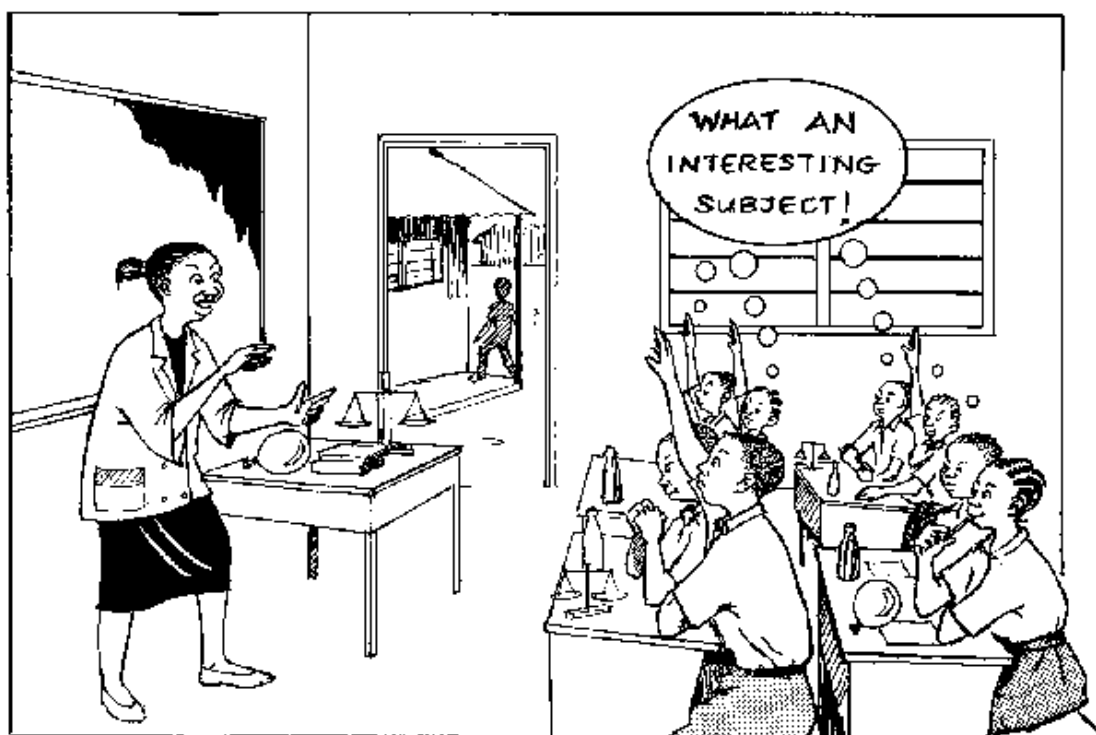

# 1. What is Physics?

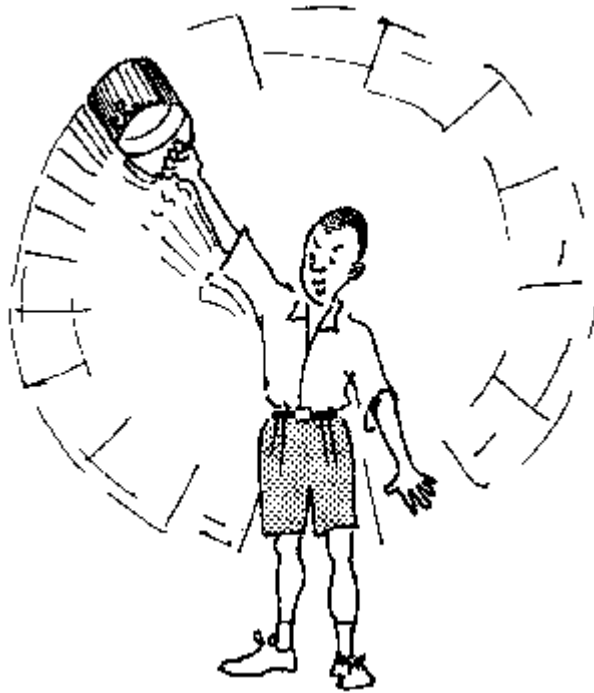

## 1.1 What is Physics?

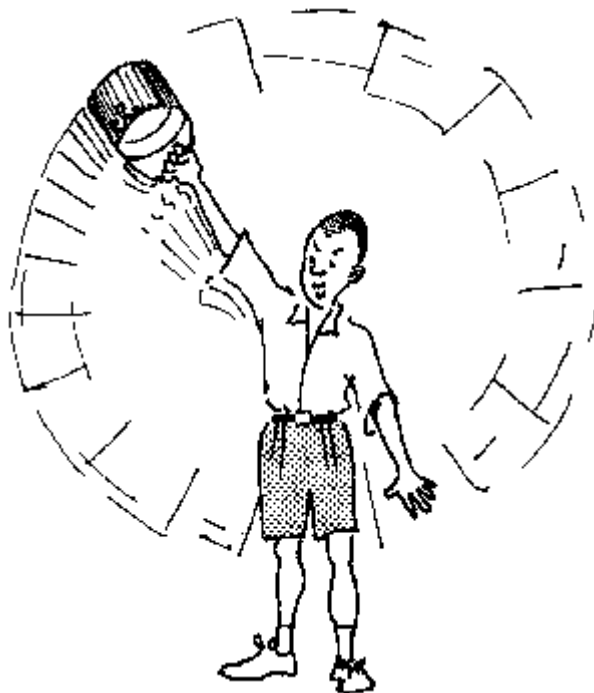

A bucket of water is sufficient to start investigating the effect of centripetal forces. Fill the bucket with various quantities of water and you will learn even more by doing. Increase the number of revolutions of the bucket.

Physics must not be a boring, tough subject, just good for exams and to be understood by a few "experts" only. Physics should not happen in books only. It is everywhere where things are. The teaching of science without experiments is just like a ngoma without dancers.

Pupils learn more and better by doing. Stimulate them to investigate their environment through easy to carry out experiments. Ask the pupils to make a list of physical phenomena which can be observed in their environment. Let the pupils enjoy physics. This sourcebook shows how this can be achieved.

## 1.2 Laboratory Techniques



Imagine you would buy different kinds and different quantities of meat. The butcher will have to weigh and then calculate the price for each kind of meat and produce the total bill. Thus, measuring and the collection of data happen nearly everyday in our life.

The tailor takes the measurements of his customer and of the material needed for a suit. The milkman measures the volume of the milk sold. The technician measures with a calliper the diameter of a screw and even at school the time of each period is measured. Especially in engineering precise measurements are indispensable.

Therefore physics as a subject has to introduce even beginners to the principles of measuring and data collection. "I have no measuring instruments in my school," you may say. Really? Let the students enjoy physics starting with measurements which are easy to carry out and the construction of measuring instruments. For a lot of hints see chapter 2.

## 1.3 Basic Mechanics



Have you observed children balancing a plank like a seesaw? They know how a big and a small child can balance although they are of different weight.

Usually they do not know what a fulcrum, a load distance and a moment of force is. However, such basic mechanics dominate an essential part of our daily life. We encounter motion, friction, inertia, work and power almost every day. We also learn in a practical way about density, pressure of fluids or gases. Work, energy, power and other physical phenomena look very abstract in books but happen every day. Also the movement of earth, moon and the planets which determines the lengths of our days, months and years, has to do with basic mechanics such as motion, mass attraction and centripetal forces.

Ask the students to discuss where such basic mechanics phenomena can be observed. Discussing only? No! There are plenty of meaningful experiments. For these, see chapter 3.

#### 1.4 Matter

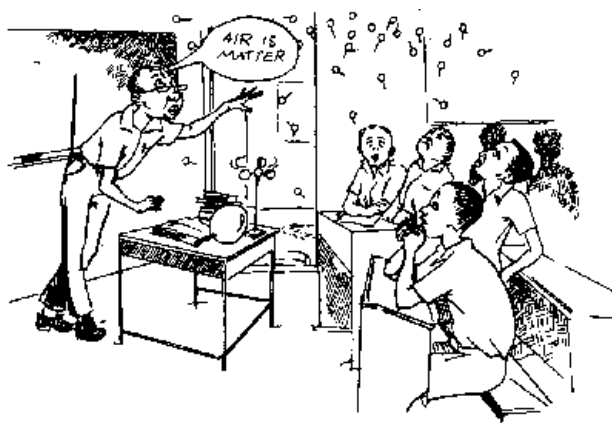

A chair can be touched. Water in a bucket also. But air? Can you imagine that while you are reading these lines your nose is punched more than 100 billion times by air molecules?

The environment around us, whether in solid, liquid or gaseous state is made up of billions of tiny particles which are either molecules or atoms. These particles which constitute air are so tiny, that we cannot see them even by a powerful microscope. However, the students can be given an idea of the particle structure of matter by indirect evidence.

Discuss with the students from which evidence we can conclude the existence of particles and ask them to write an essay about this. You may think, there are no experiments possible about states of matter, diffusion, molecular forces and other properties of matter? Failed! For details see chapter 4.

#### 1.5 Thermal Physics



Would you ever touch the handle of a hot pan? Not me. Would you put margarine just aside of the pot? Not me. Would you hold your hand right above the hot water? Not me. This is because, we know a lot about thermal physics by daily experience. But we do not always relate this knowledge with what we learn at school about heat conduction, heat radiation or heat convection as is the case in the examples mentioned above.

Thermal physics has also to do with thermal energy and the measurement of temperatures, with calorimetry, change of states, expansion, etc. Ask the students to talk about everyday thermal phenomena and to write about these. Why should we teach this topic by talk and chalk only, if there are illustrative experiments which do not require a lot of equipment and which are not time consuming in their preparation and performance? See chapter 5.

## 1.6 Wave Motion

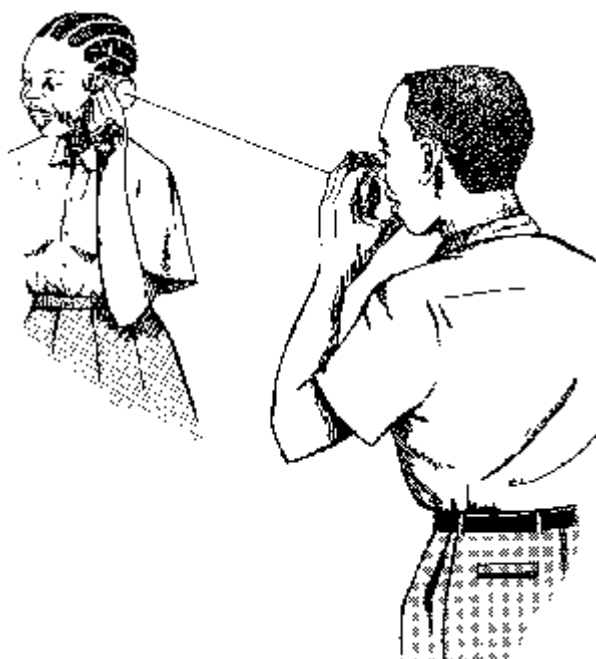

Communication through spoken words has to do with the transport of waves. Telephone and radio are well known. But do we think about waves when we hear a music band, when a crow is croaking or when children are playing with a string telephone?

However, children know how to construct a good string telephone. Two tin cans are needed, also a string which is tied with a knot in a hole at each can. The string should be stretched and not be slack. It should not be heavy. All this is everyday knowledge about the transport of sound waves.

But teaching about waves does not mean only sound waves. We already have mentioned electromagnetic waves. Water waves we notice in a water puddle as well as in a cup of tea.

Produce waves in physics not only by talking. Meaningful and simple experiments are possible on many themes of this topic. No time? Hand experiments are always brief, illustrative and can be carried out with everyday things. Get ideas by reading chapter 6.

## 1.7 Geometrical Optics



When we hear about optics, the optician, eye glasses and lenses come into our mind. But that is not all what optics is about. Optics is also about the reflection of an image in a mirror or in a water puddle. The water surface is like a mirror. The image to be seen is inverted and it seems to be as far behind the water surface as the object is in front of it. Perhaps there are no curved mirrors at your school to teach about concave and convex mirrors. No problem. Take a polished spherical spoon and you will be able to perform an interesting lesson. If you have no equipment for an introduction to the principles of how lenses work, this is no problem too. Take a fused and water filled transparent bulb and you can be sure about the admiration of your students about your creativity in teaching physics by doing. Certainly not all themes can be taught by simple qualitative hand experiments only. But you may be astonished to see how many there are for eye catching demonstrations. For details, see chapter 7.

## 1.8 Electricity and Magnetism

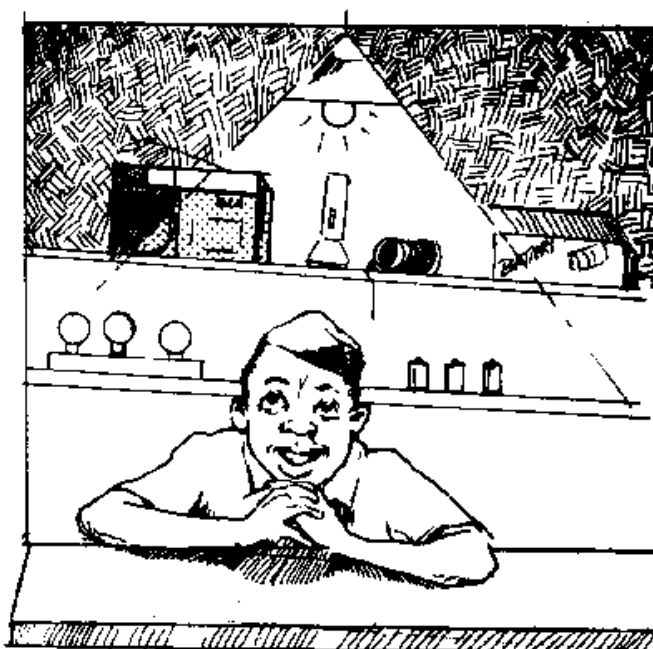



Effects of electricity can be observed nowadays nearly everywhere. A light bulb lights the room, a radio enchants our ears and a torch helps to find our way in the darkness and last but not least we do owe a cool soft drink to a refrigerator. The understanding on how electric apparatus work is essential nowadays.

But electricity does not only mean a current flows in a circuit. It means also static electricity or a lightning during a thunderstorm. The topic electricity is closely related to magnetism. Without magnets electric motors would not work. Loudspeakers work with magnets and even a simple bicycle dynamo has one. In harbours you can see how "attractive" magnets can be to lift heavy loads. Do you think that the teaching of electricity by doing is difficult, needs a lot of equipment and is even dangerous? Brief and attention attracting experiments wanted? Only look on chapter 8.



## 2. Laboratory Techniques



### 2.1 Collection of Data

Man's progress is due, in large part, to his ability to measure and hence collect data with greater and greater precision. Young pupils should learn, generally, about how to obtain data by carrying out simple experiments. They should be introduced to the basic measurements of mass, distance and time. They should be trained in recording and in graphical analysis of data.

#### 2.1.1 Data on Weighing

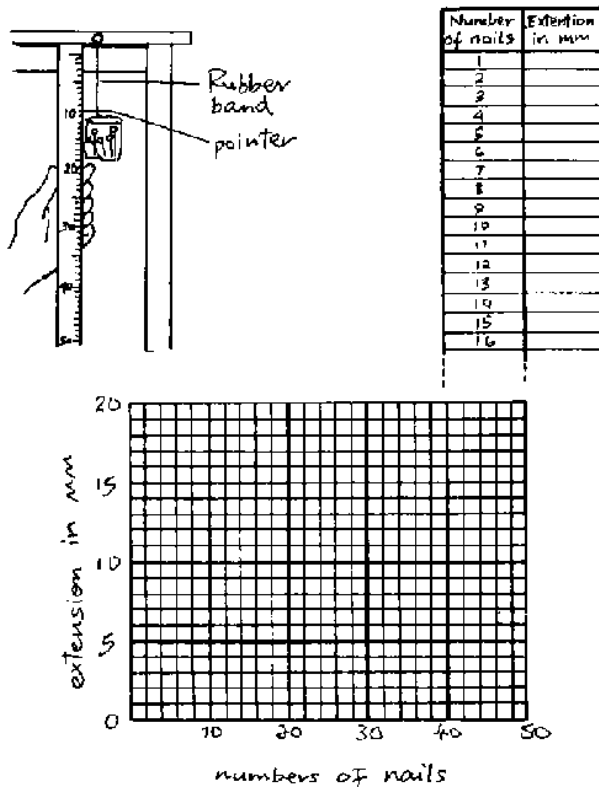

A rubber band is fixed at one end and is attached both to a wire hook at the other end (which serves as a pointer) and a small plastic bag (e.g. for wrapping groundnuts). Fill the bag with nails in successive small numbers (which you count) or other objects of similar weights. Let the pupils measure the extension of the rubber band, each time they add more nails, record the readings and ask them to draw a graph (see the figure).

### 2.1.2 Data on Distance

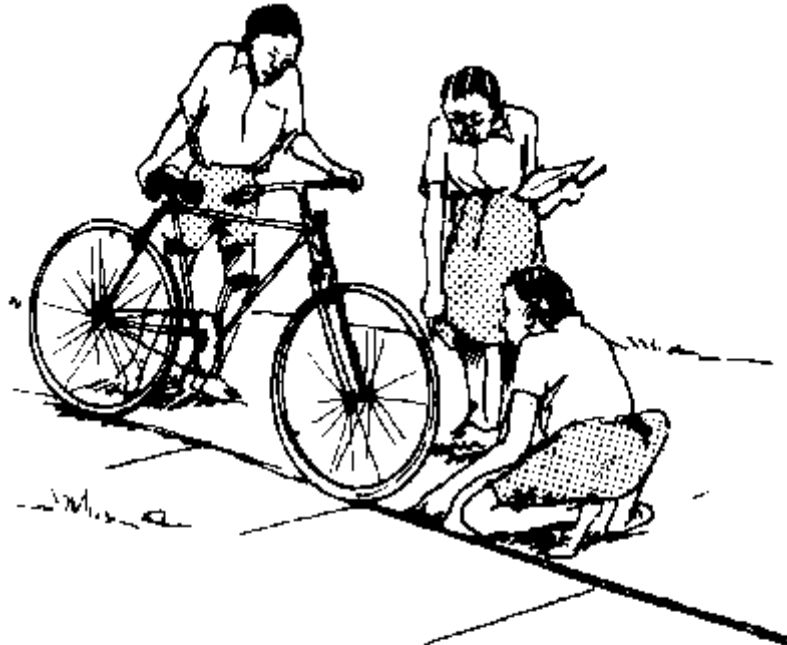

TURNS	DISTANCE

Make a mark on the tyre of a bicycle or a car at a point just next to the surface of the pavement. Turn the tyre to move straight forward along the pavement and measure and record the length of one turn. This is the distance covered when the mark is about to make contact with the pavement again. Let the pupils repeat the experiment several times in each case with the tyre allowed to roll a few more turns. The distance is calculated in each case and a graph is drawn.

### 2.1.3 Data on Time

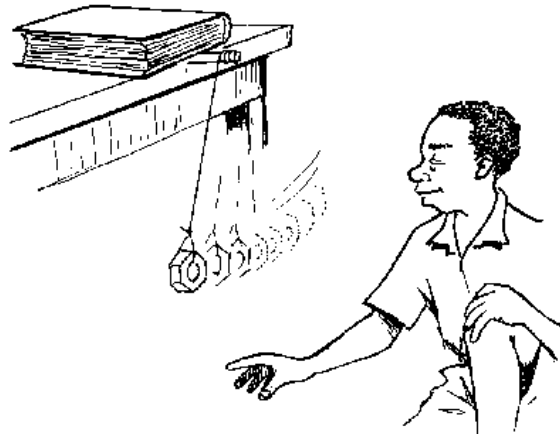

LENGTH OF PENDULUM	SWINGS		
	5 cm	30 cm	25 cm
50 cm			
75 cm			
100 cm			

Fix a thin thread somewhat off the edge of a table and hang e.g. a nut at a distance of 50 cm on it. You have made a pendulum. Hold the (nut) pendulum and pull it to one side, so that it is horizontally displaced by 5 cm. Start counting the number of oscillations (back and forth) that take place in one minute. Record your result as shown. Repeat the experiment by horizontally displacing the nut by 10 cm and 15 cm consecutively. Try to find out the length of a pendulum which happens to oscillate just 60 times in one minute.

### 2.1.4 Data on Velocity

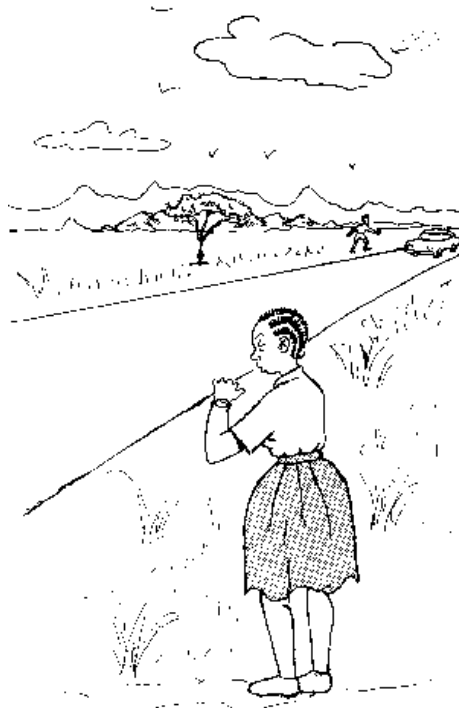

Mark a distance of 100 metres along a nearby road or playground. Note the time taken for a car, a bicycle or a sprinter to cover the distance as follows. One pupil waves down his hand as either the car, bicycle or sprinter crosses the 0 metres mark. Another pupil with a watch, starts timing at the same time. A third pupil at the 100 metre mark waves down his hand as the moving object crosses the 100 metre mark and at this instant the timekeeper stops his watch.

Pupils record the time taken for each case and figure out the respective velocities.

### 2.1.5 Simple Beam Balances

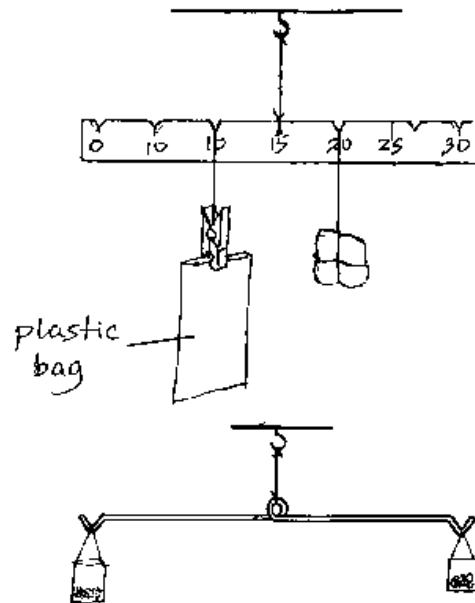

A balance for teaching moments and equilibrium can be made from a ruler or a thin wooden bar. A balance for introducing equilibrium consists of a wire with a loop for hanging in the centre and with two hooks at the ends.

### 2.1.6 Sensitive Laboratory Balance

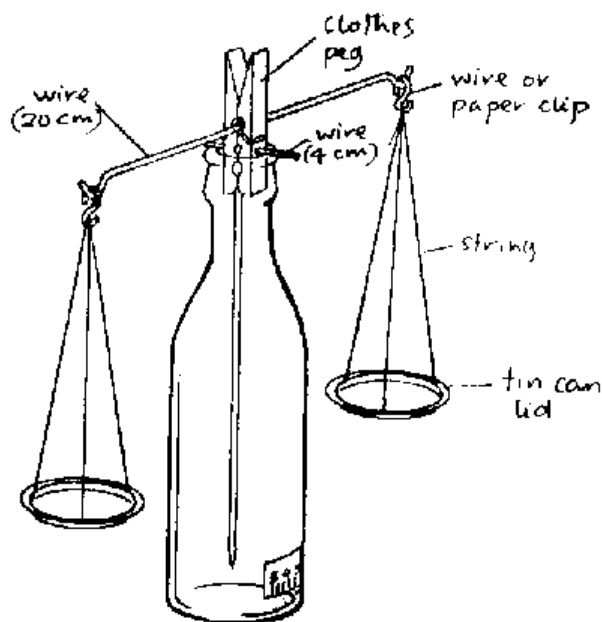

Drill a hole through a clothes peg below the spring for a wire or nail to pass through. Fix a wire right in the spring as a balance beam, and another one in the mouth of the peg as a pointer. (The shorter the pointer, the more sensitive the balance). Fit the arrangement in a wide mouth glass bottle or a plastic bottle marked with a scale.

### 2.1.7 Weights

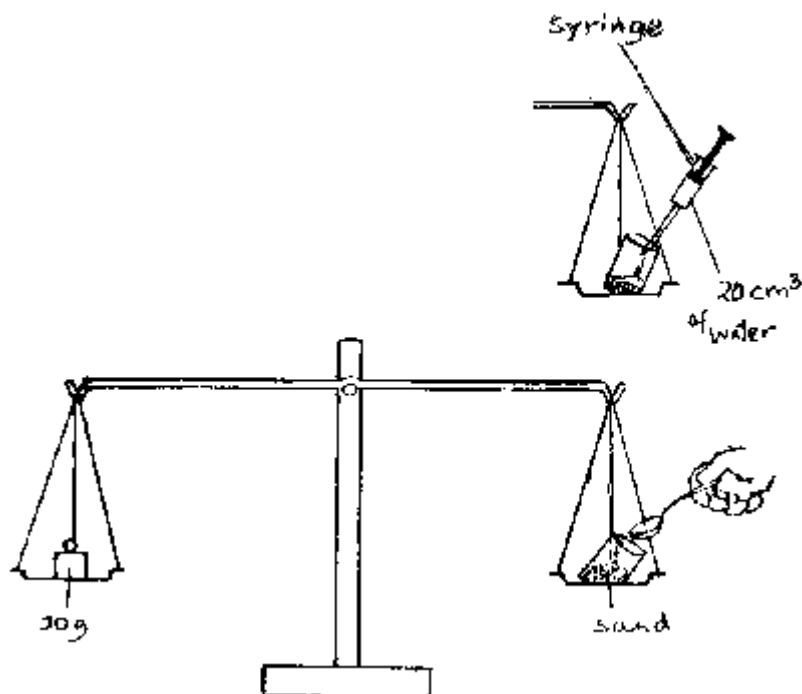

(a) Fill small plastic bags with sand or small stones and compare them with standard weights. Label and seal the bags with a small flame.

(b) Where there are no standard weights, use syringes or measuring cylinders to fill plastic bags with equal amounts of water. Use the fact that  $1 \text{ cm}^3$  of water has a mass of 1 gram.

### 2.1.8 Weighing Pans

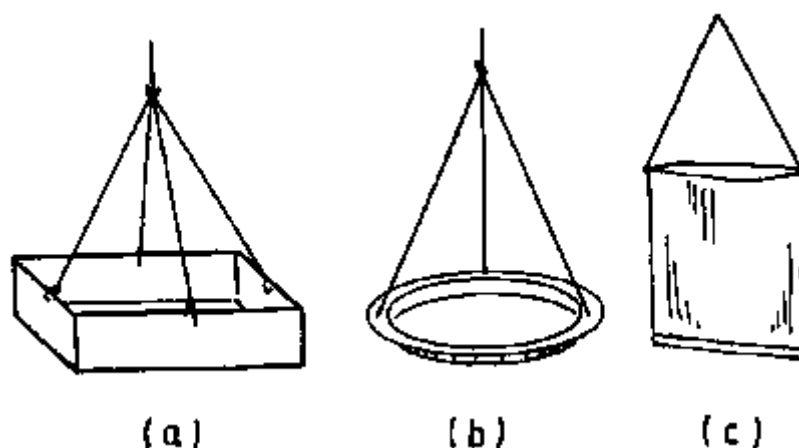

Weighing pans can be made from match boxes (a), plastic lids (b), or even small plastic bags (c) as used for wrapping ground nuts.

### 2.1.9 Measuring Liquids

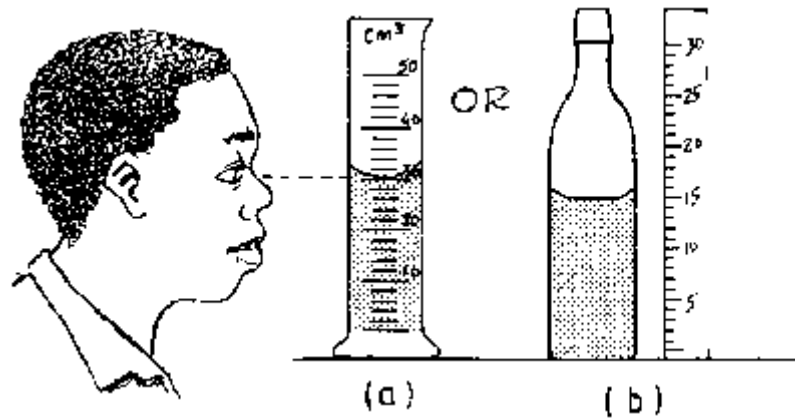

The volume of liquids can be measured by accurately reading the meniscus (a). The principle can be taught with a transparent bottle and a ruler (b).

### 2.1.10 Measuring Different Densities

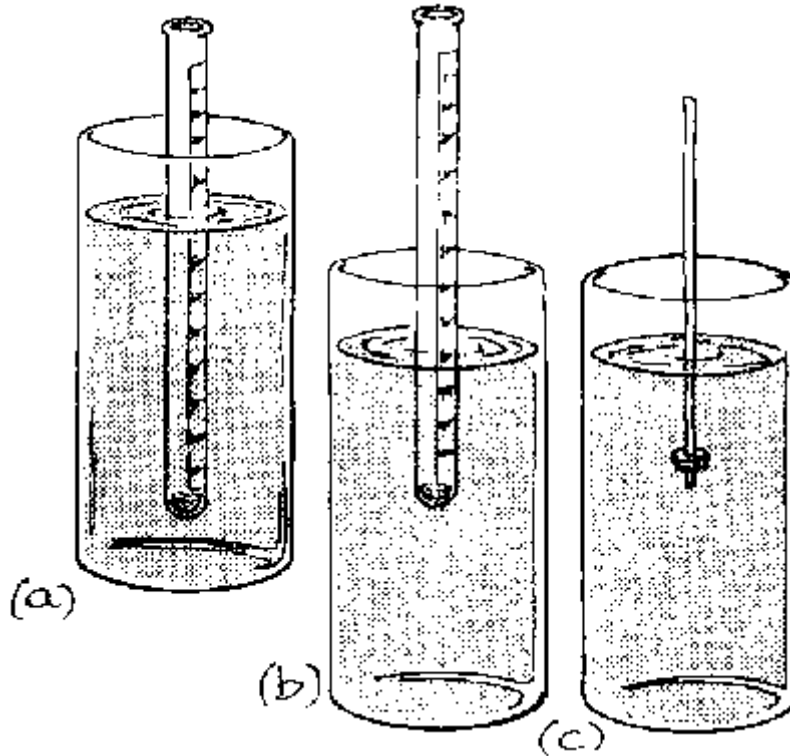

Fill a test tube with sand to keep it upright in water (b). Place a paper scale inside or fix a nut or a stone at one end of a wooden stick. Make regular marks (scale) along the wooden stick (a). Dip the tube or wooden stick in water (b), oil (a), (or kerosene, ethanol, etc.) and record in each case the extent to which the device sinks.

### 2.1.11 Measuring Irregular Bodies

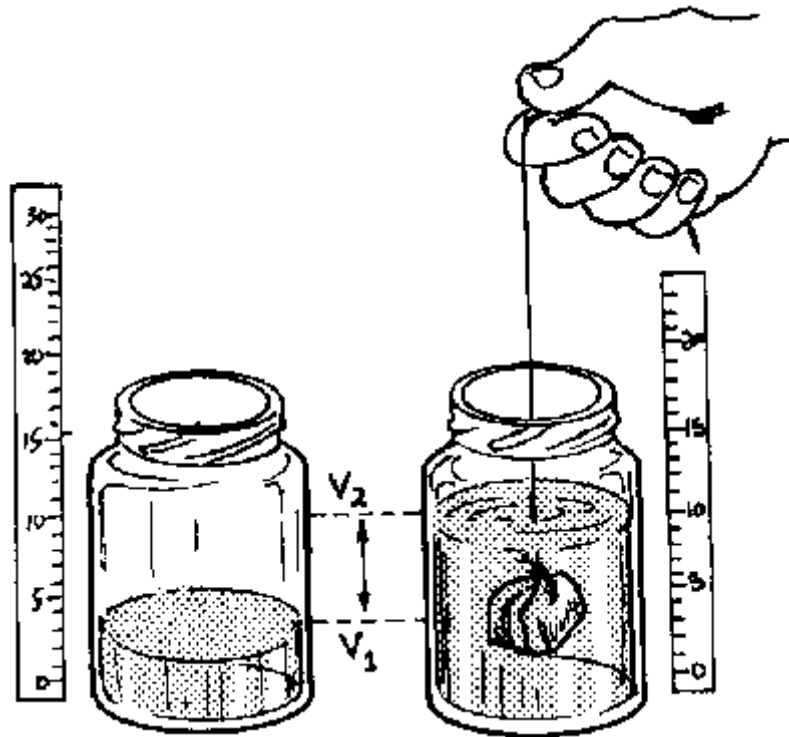

The volume of an irregular body (stone) can be measured by hanging it on a thin thread and dipping it completely in a measuring cylinder containing water. The difference in the volumes of the water read before and after completely submerging the irregular body is its volume. Only the principle is shown here.

### 2.1.12 Measuring Long Distances

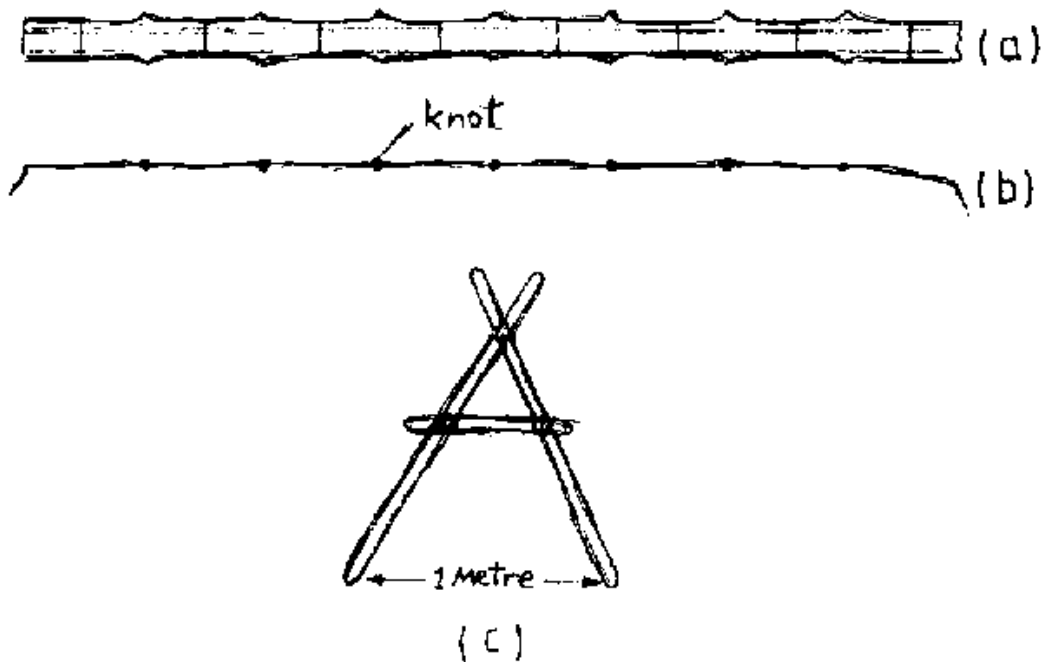



Measuring devices can be made from wooden sticks (a,c) or from strings by making knots at definite intervals (b). The sticks can be arranged closely together in succession to measure distances on uneven ground.

### 2.1.13 Wind Direction

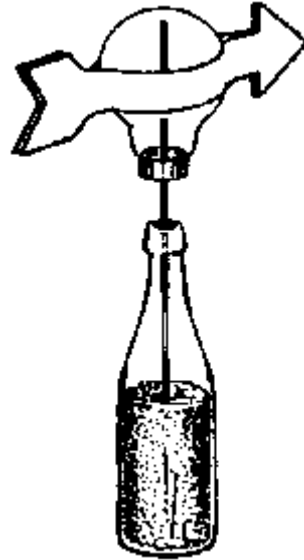

Take an opened fused bulb (for opening see appendix), place a piece of stiff wire so that the bulb turns with low friction on the tip of the wire. Fix two paper arrows folded around the bulb. Dip the wire in a sand filled bottle as a support. The device works excellently.

### 2.1.14 Wind Speed

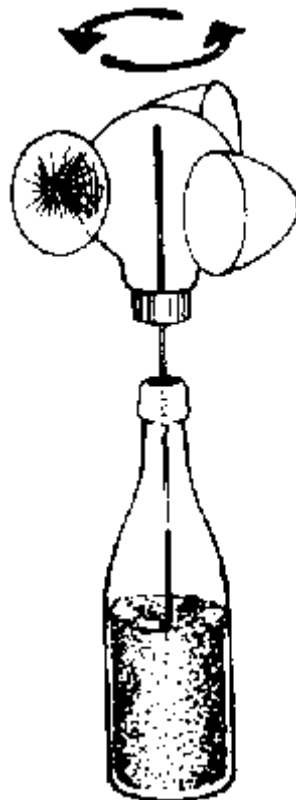

Fold 3 cones from round paper disks (preferably from cement bags or other resistant paper). One cone should be painted outside in a different colour for a better counting of the number of revolutions. Glue the cones to the bulb. Insert a piece of stiff wire which can be dipped in a sand filled bottle as a support (see experiment 2.1.13).

### 2.1.15 A Simple Current Indicator

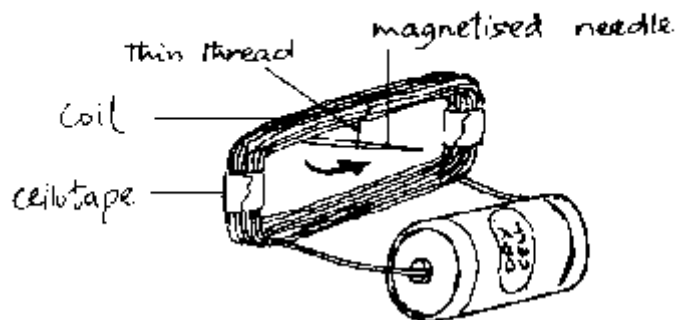
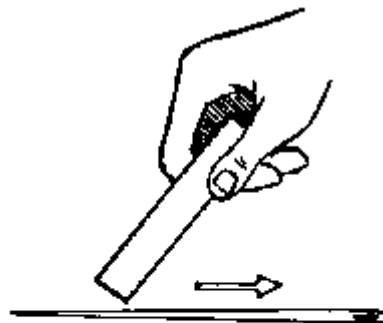

Wrap about 10 turns or more of insulated wire (from a used motor coil or as used for electric bells) round a match-box in order to get the required shape of the coil. Suspend a magnetised steel needle (or a magnetised piece of a bicycle spoke) with a thin thread inside the coil. You can magnetise the needle with a magnet (taken from the loudspeaker of an old radio) by moving it along for about 30 times always in the same direction. When a current flows through the coil, it deflects the needle. A change of the poles changes the deflection.

### 3. Basic Mechanics

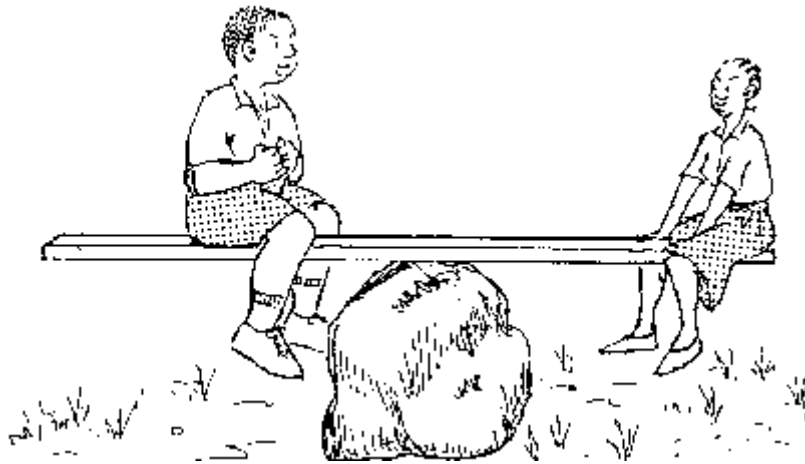

#### 3.1 Rectilinear Motion

This section introduces the uniform and the accelerated rectilinear motions, i.e. those having constant velocity and constant acceleration.

Definitions:

Displacement = distance measured along a straight line

Velocity = displacement  $\div$  time taken

Acceleration = change in velocity  $\div$  time taken

Uniform and accelerated motions play an important role in the movement of cars, buses, trains, ships and aeroplanes.

##### 3.1.1 Uniform Motion

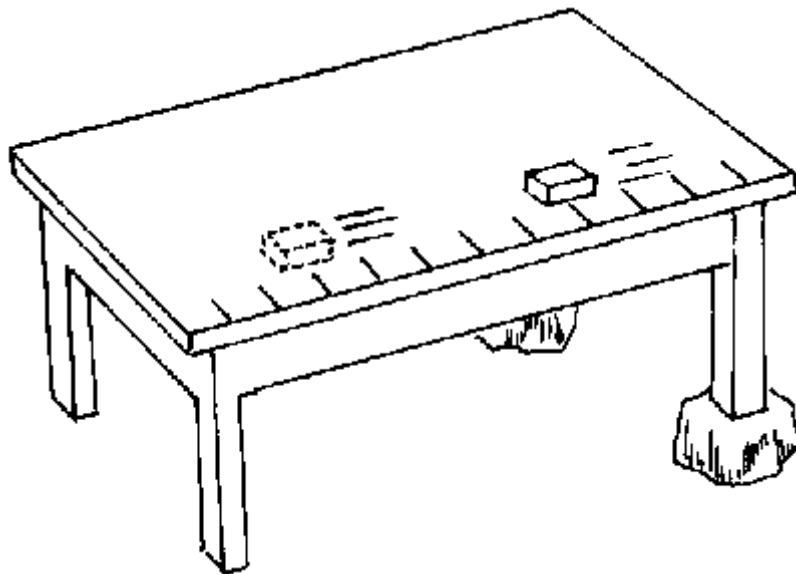

**P:** Place chalk marks along the long side of a smooth table or plank at an equal distance of 10 cm. Then tilt it so that a matchbox loaded with a stone will just not start to move. Then give the box a little push so that it will move.

**Q:** Does it need always the same time from one mark to the next?

**O:** If not, change the inclination of the table or plank until it does.

**E:** If so, this is a *uniform* rectilinear motion: the velocity is constant, there is no change in velocity, thus the acceleration is zero.

**A:** Where does this motion occur in daily life? - For example, a bus, a train or a boat going at constant speed on a straight line path.

### 3.1.2 Accelerated Motion

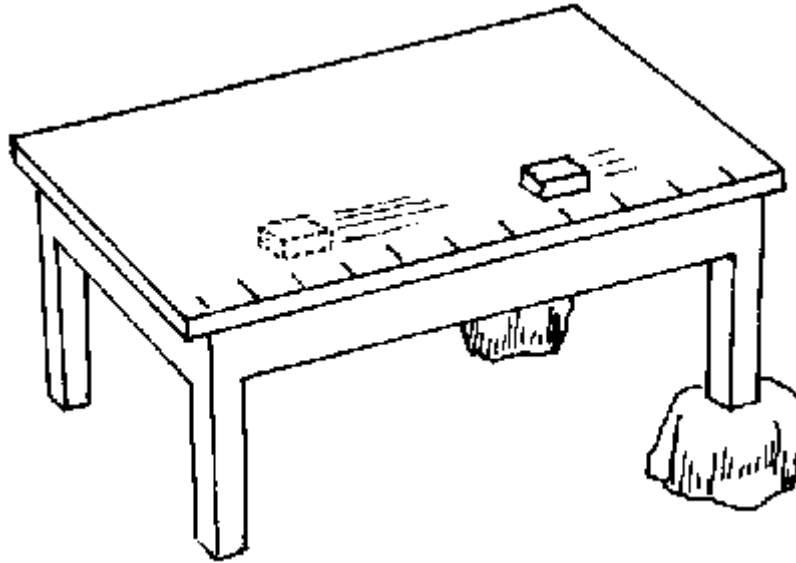

**P:** Tilt the smooth table or plank more than in experiment 3.1.1.

**Q:** How is the time which the matchbox needs to cover the distance between two marks? Is this time getting shorter when the box moves down?

**E:** If so, this is an *accelerated* motion. Its velocity changes as the box moves down. Its velocity *increases*. Thus, it is an accelerated rectilinear motion.

**A:** Where do such motions occur in daily life? - For example, a stone falling down; a bus accelerating after the stop; a bus braking before a stop.

### 3.2 Forces

What is a force? *A force is a push or a pull on a body.* It can be recognised by its effects on a body which are:

Change in velocity of a body (accelerating, braking, changing the direction of the movement); Deformation of a body (changing its shape or size).

### 3.2.1 The Effects of Forces

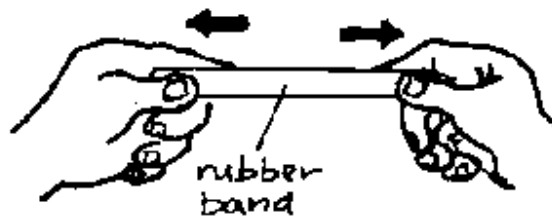
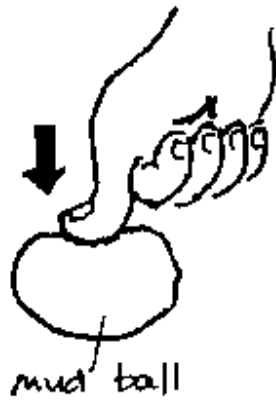
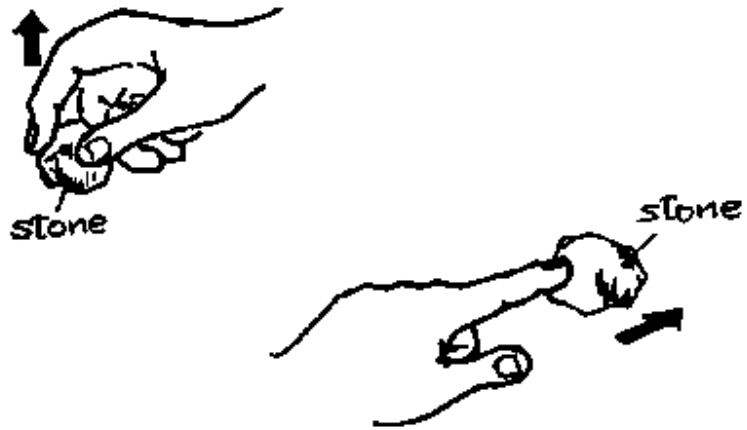

**P:** Show the effects of forces by pushing, pulling, lifting, turning a stone; by stretching a rubber band.

**Q:** How can you group these effects of force?

**E:** Pushing, pulling, lifting, turning *change the velocity of a body*. - Compressing and stretching *change the shape or size of a body*.

*A force changes the velocity or the shape of a body.*

### 3.2.2 Making a Newton Balance

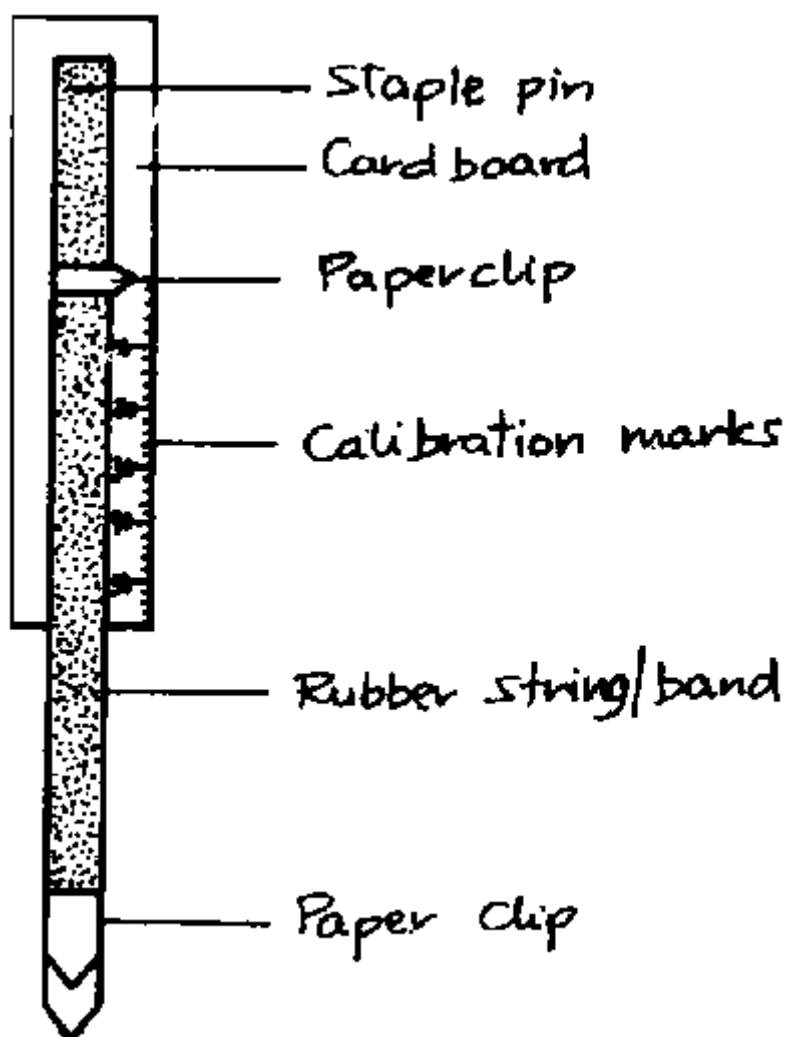

*Forces are measured with a Newton balance.*

**P:** Take a strip of card board or a wooden lath. Using incisions or a nail fix a rubber band on it. (The stronger the rubber band, the larger the force you can measure.) Attach one paper clip as a pointer as shown in the figure. Then fix some paper clips as a hook at the bottom end of the rubber band.

Now *calibrate* the balance in *newtons* using either a standard set of weights (e.g. borrowed from the lab of a well equipped school) or another Newton balance: a weighing piece of 1 g mass has a weight of 0.01 N; one of 10 g mass has a weight of 0.1 N; one of 100 g mass has a weight of 1 N and so on. Draw marks accordingly on the scale of the balance.

**H:** Never apply such a big force that the pointer does not go back to the zero mark when the force ceases.

### 3.2.3 Direction of Forces

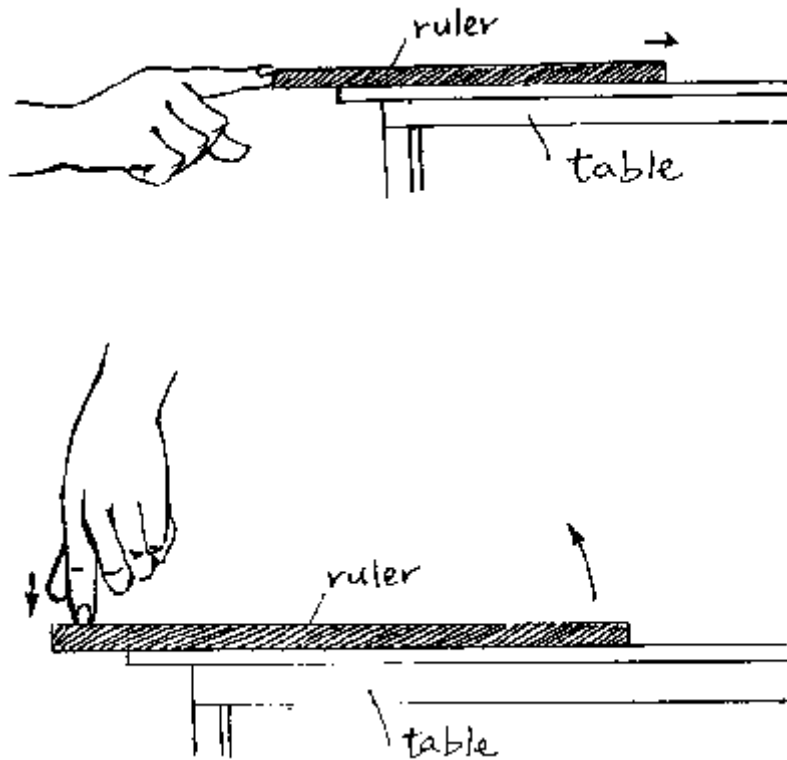

**P:** Show that the direction of a force is important for the effect of a force by applying a force on a stick in various directions, see the figure.

### 3.2.4 Forces as Vectors

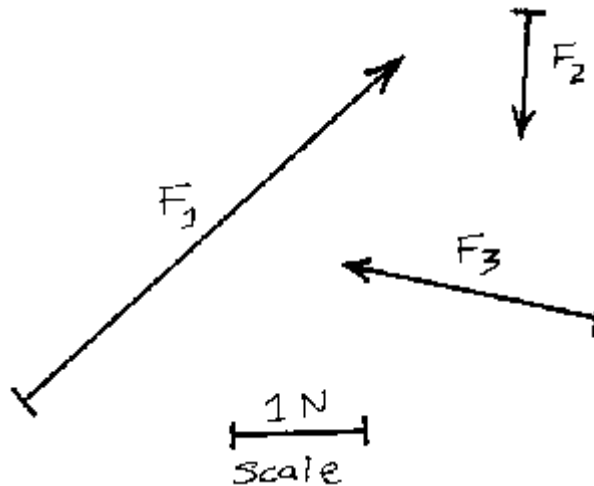

*Quantities which have both direction and magnitude are called vectors.*

Thus, for example, force, displacement, velocity and acceleration are vectors.

Vectors are drawn as arrows whose length gives the magnitude.

Draw some forces like those in the above figure and a scale on the blackboard and ask the students to give the direction and magnitude of these forces.

### 3.2.5 Measuring Forces

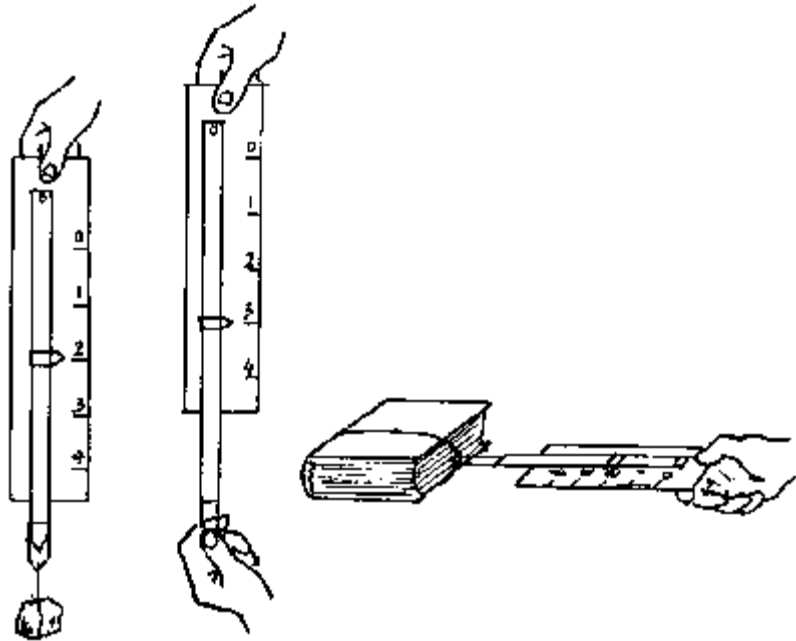

**P:** Using your Newton balance measure various forces like the force needed to lift different stones, the force needed to pull a book sliding over your desk, the force to stretch a spring, etc.

### 3.2.6 Drawing Forces

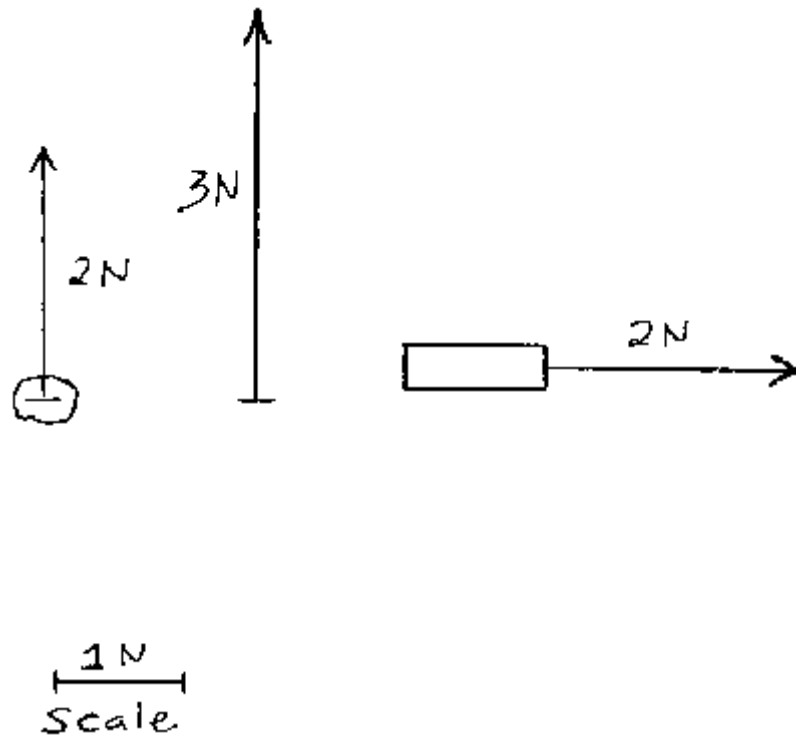

**P:** Ask the students to draw all the forces which you have measured in experiment 3.2.5 as vectors in their notebook.



### 3.3 Weight and Mass

The *weight* of a body is the pull of the earth on it. Thus, weight is a *force* measured in newtons. It is a *vector* directed to the centre of the earth. It is measured by the Newton (spring) balance.

The *mass* of a body is a measure for the quantity of matter in that body. Thus, it is a *scalar* which *stays everywhere the same* while the weight of body will decrease when its distance to the centre of the earth increases. It is measured by the beam balance.

#### 3.3.1 Weight as the Pull of the Earth

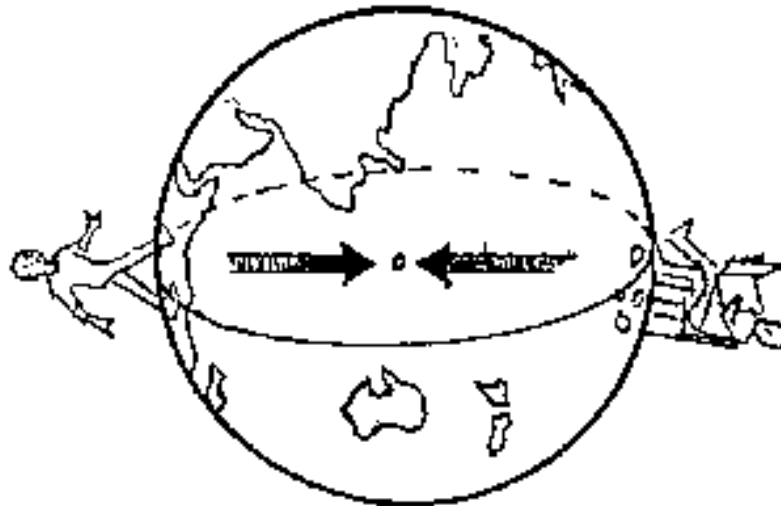

**P:** Hold a stone at the level of a table plate and release it.

**Q:** What do you observe?

**O:** It will fall down to the floor.

**E:** It changes its velocity, i.e. a *force* must act on it. This force is the pull of the earth on the stone. This pull is always directed to the centre of the earth. Thus, the weight has magnitude and direction. It is a *vector*.

Hence, as the figure shows, the weight of people in different regions of the world has different directions. However, it is *always directed to the centre of the earth*.

The *magnitude* of the weight of the same body is *not* everywhere the same. The further away from the centre of the earth the body will be, the less its weight will become.

### 3.3.2 Mass as the Quantity of Matter

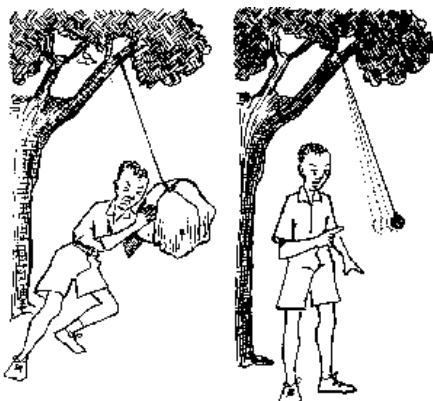

**P:** (a) Suspend a large and a small stone using long pieces of string (e.g. from a branch of a tree). Try to push the two stones. Then try to stop them.

**Q:** Which stone is harder to push? Which is harder to stop?

**P:** (b) Take a ball and a stone or brick of similar size. Throw both.

**Q:** Which is harder to throw?

**O:** (a) The larger stone is harder to push and to stop than the small stone.

(b) The stone or brick is harder to throw than the ball.

**E:** The greater the mass of a body, the more it resists to any change in its velocity. We say, the greater the mass of a body, the greater its *inertia*.

The quantity of matter of the same body, and hence its mass, is everywhere (e.g. on the earth, on the moon, etc) the same. Mass has no direction, thus it is a *scalar*.

### 3.3.3 Weight is Measured by the Newton (Spring) Balance

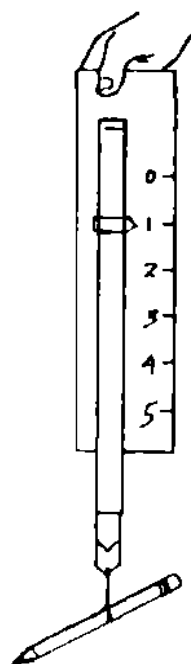

Since weight is a force, it is measured by the Newton (or spring) balance.

**P:** Take a Newton balance (see p. 15) and measure the weight of a pencil, a book, etc. in newtons.

### 3.3.4 Mass is Measured by the Beam Balance

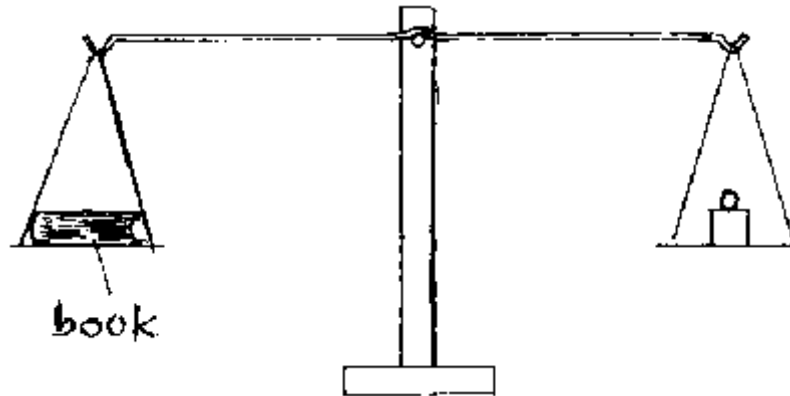

*The mass of a body is measured by the beam balance.*

**P:** Take a beam balance and a set of weighing pieces (see p. 10) and measure the mass of a pencil, a book, etc. in grams (g).

### 3.3.5 The Surprising Pencil

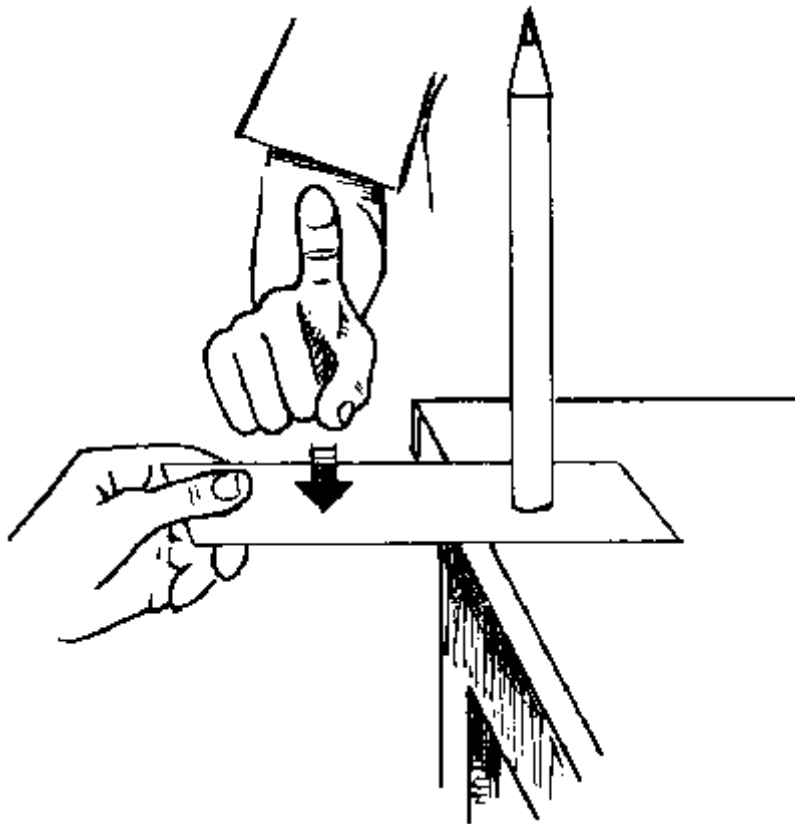

**P:** Stand a pencil upright on a strip of paper near the edge of a table. At once hit the strip with your finger so that it leaves the table, see the figure.

**Q:** What happens? How do you explain this?

### 3.3.6 The Standing Passenger in the Pick-up

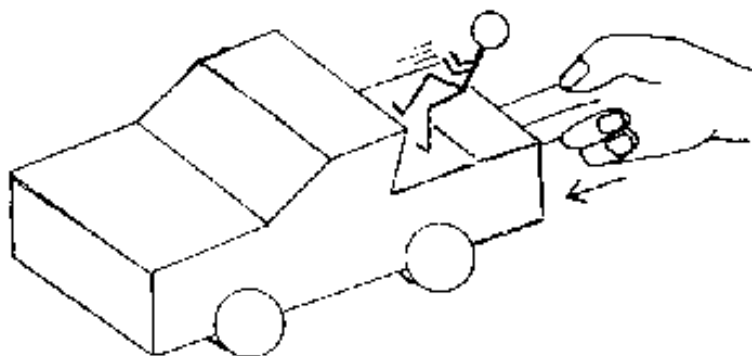

**P:** Take a toy pick-up or a box (representing a pick-up) and place a *freely standing* passenger (made of card or wood) in it. Strongly accelerate the pick-up. Make it turn a corner. Finally stop the pick-up suddenly.

**Q:** What happens to the standing passenger in each case? Why?

### 3.3.7 Kicking a Brick

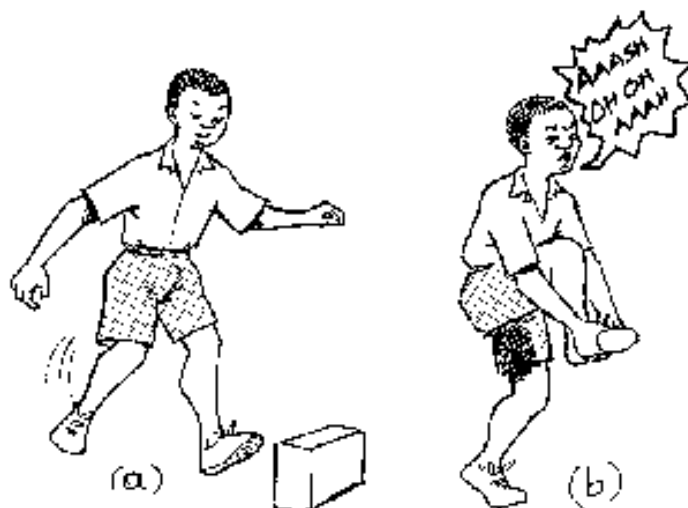

**P:** Ask students to draw the figure on a display chart.

**Q:** Why does the student feel great pain after he kicked the brick? Would the same happen, if he kicked the same brick on the moon?

**E:** He feels pain because the brick has a greater mass, and hence a greater inertia than a football. The same would happen at the moon, because the mass, and hence the inertia of the brick, is the same on the moon.

### 3.3.8 Car Crash

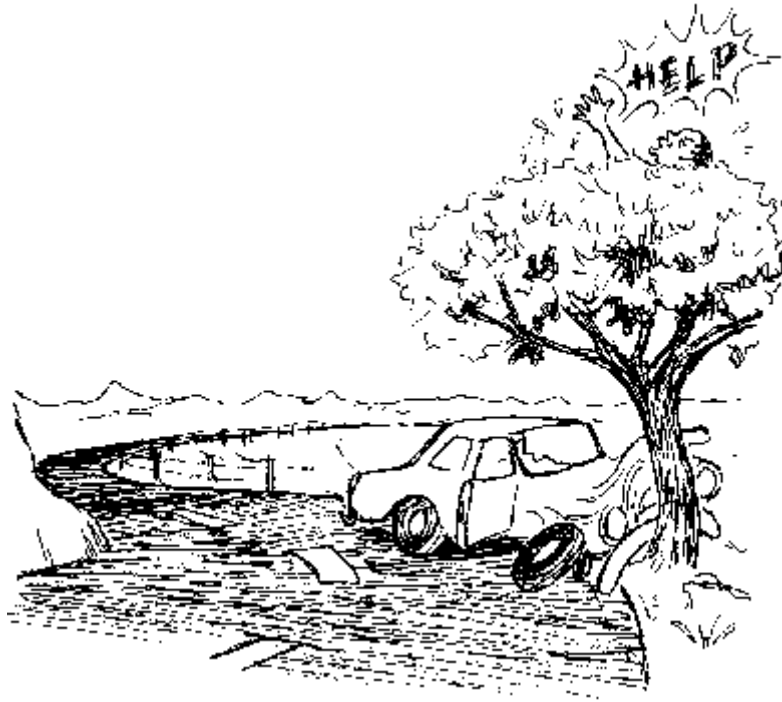

**P:** Make a display chart of the figure.

**Q:** Why did this car get so badly damaged?

**E:** The big mass of the car has great inertia. Thus, a great force exerted by the tree was needed to stop it suddenly. This force deformed the car.

### 3.3.9 The Weight Changes

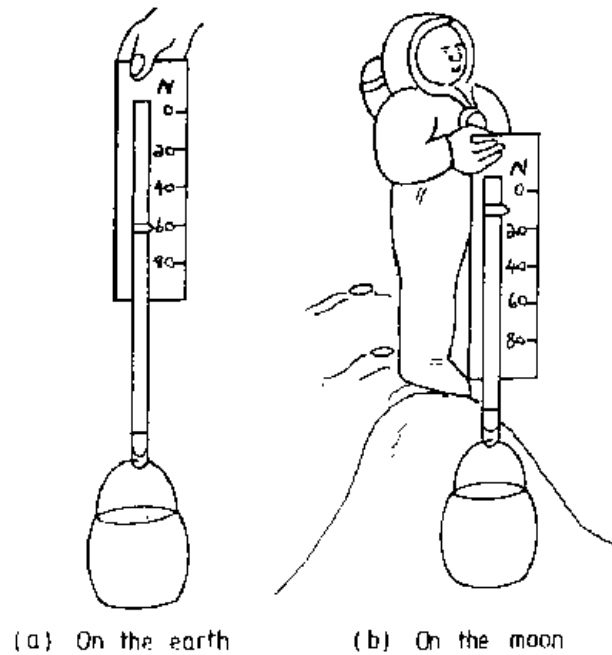

**P:** Make a display chart of the figure.

**Q:** Why is the weight of the same bucket of sand less on the moon than on the earth?

**E:** The weight of a body depends on the place where the body is. It is *not* everywhere the same.

### 3.3.10 The Mass Stays the Same

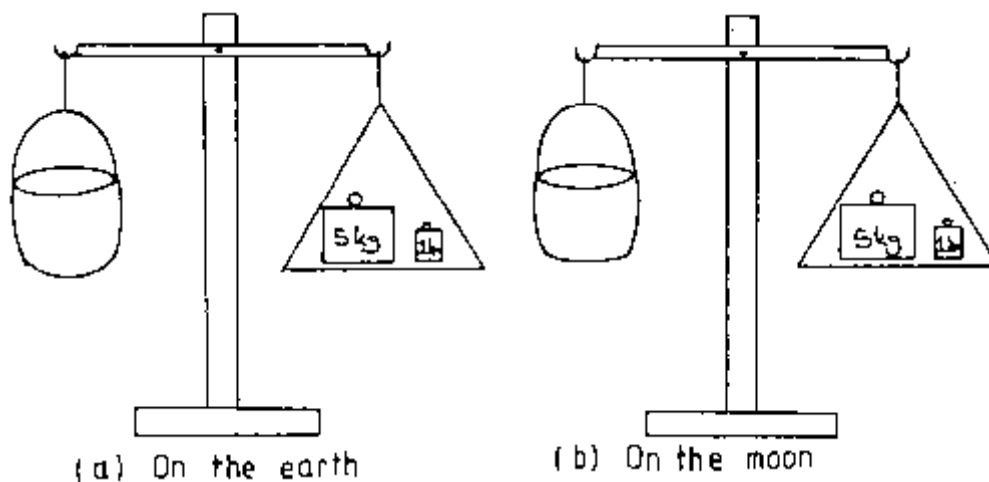

**P:** Make a display chart of the figure.

**Q:** Why is the mass of the bucket of sand the same on the earth and on the moon?

**E:** The quantity of matter of the bucket has not changed, hence its mass has not changed.

### 3.4 Centre of Gravity and Stability

This section deals with the moment of a force, the centre of gravity (centre of mass) and stability.

*Moment* of a force = force x perpendicular distance from the pivot

In equilibrium: total clockwise moment = total anti-clockwise moment

The *centre of gravity* (centre of mass) is the point in which the total weight of the body seems to act.

The stability of a body depends on the position of its centre of gravity (COG).

A body is in *stable* equilibrium if a small movement would rise its COG.

A body is in *unstable* equilibrium if a small movement would lower its COG.

A body is in *indifferent* equilibrium if a small movement would keep the COG at the same level.

### 3.4.1 Moment of a Force

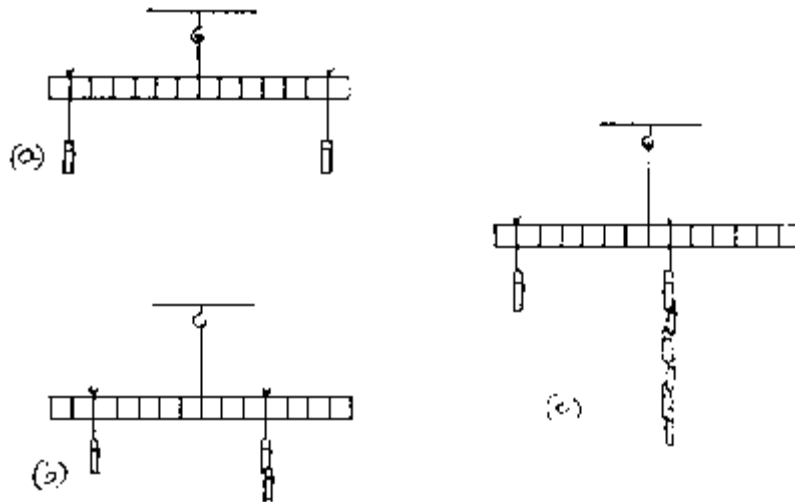

**P:** Cut a piece of cardboard 40 cm x 3 cm and attach a supporting string exactly at the middle of it in a hole near the top (see figure). Mark six 3 cm spaces on each side of this middle point (*fulcrum*). Suspend this balance e.g. from the back of a chair and balance it by cutting off a little from the heavier side. Tie pieces of thread of about 20 cm length into loops about 7 cm long to support the weights. Use e.g. *equal* clothes-pegs as weights and balance them in many ways (see fig.).

Multiply weight x distance (from the fulcrum) for each side of the balanced beam.

**Q:** Prepare a table for several weights and distances from the fulcrum.

**E:** A force acting at a distance from a fulcrum has a *turning* effect which is called *moment* or torque. It can be calculated:

Moment = force x perpendicular distance (from the force to the fulcrum)

Our table shows that *the clockwise moment must be equal to the anti-clockwise moment in order to achieve equilibrium.*

**A:** The beam balance (see p. 10), the roman steelyard and other levers (see section 3.10).

### 3.4.2 Centre of Gravity (COG)

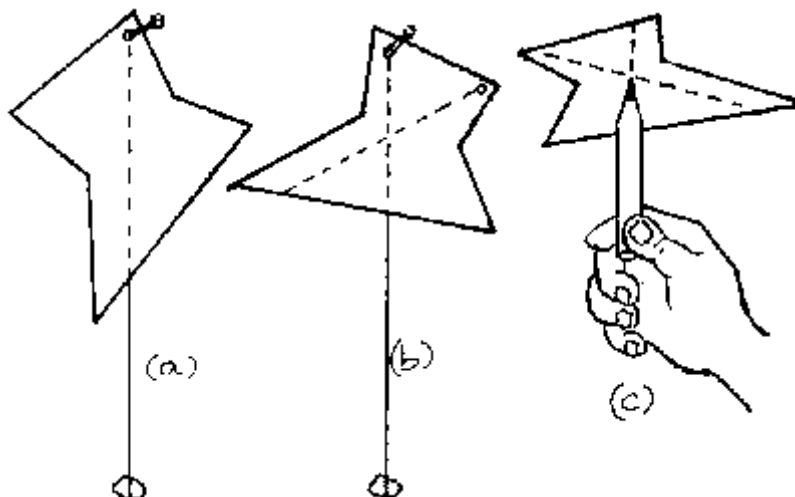

**P:** (a) Cut a piece of card into an odd shape (see fig.(a)). Suspend it from a nail and attach a string with a stone. Mark the position of the string using two crosses. Join these using a ruler to form a pencil line.

(b) Repeat (a) but fix the nail in another position on the card (see fig.(b)). Where the two pencil lines meet is the *centre of gravity* of the card.

(c) Now support the card with the tip of a pencil below the centre of gravity.

**Q:** What do you notice about the stability of the position of the card?

**E:** The position of the card remains stable as long as it is supported in the centre of gravity because now all the moments of the weights of all the mass particles of the card balance.

### 3.4.3 The Funny Jumper

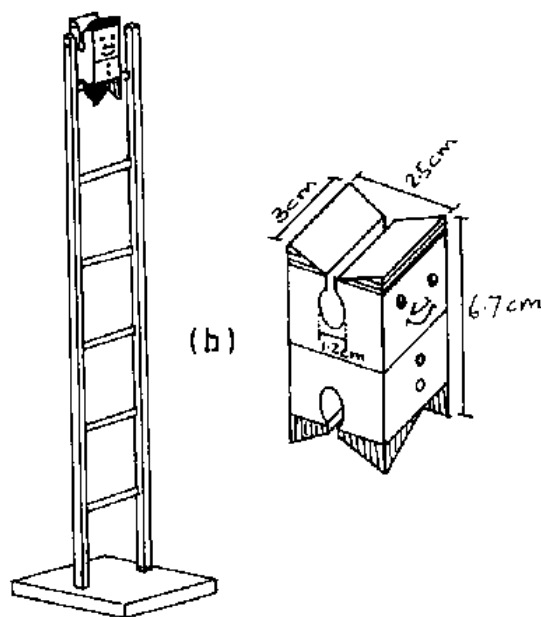
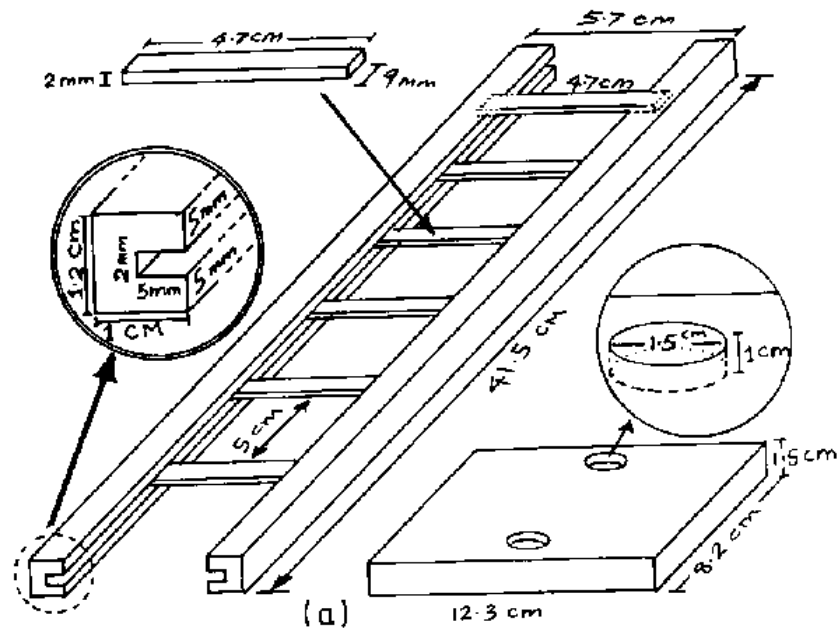



**P:** Ask a carpenter to make the funny jumper according to fig.(a) and (b). Place the jumper *feet down* on the uppermost step of the ladder.

**Q:** What happens? Why?

**O:** The jumper jumps from one step to the next down the whole ladder.

**E:** First the centre of gravity of the jumper is above a step of the ladder. This is an *unstable equilibrium* since the COG is lowered when the jumper turns round to hang on that step. However, due to the slot it has, it then falls down to be *above* the next step. Thus, the process is repeated until the jumper meets the ground level.

### 3.4.4 Balancing Nails

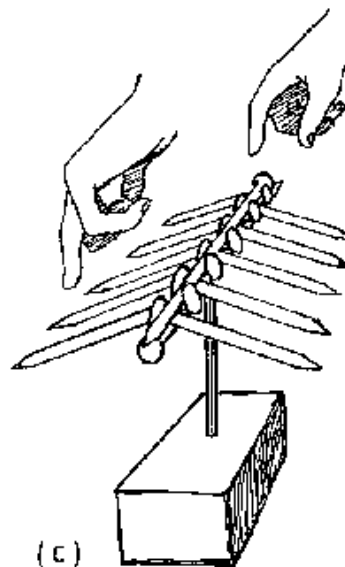
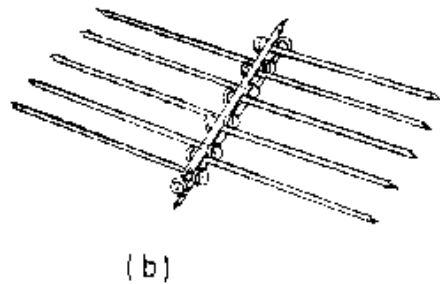
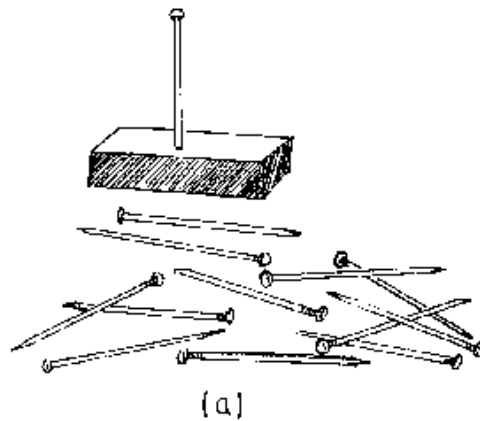

**P:** Give the students 2 inch nails (see fig.(a)) and ask them to balance them all on top of the nail which was fixed on the piece of wood. In doing this, the nails must neither be bent nor glued together etc.

This may be a challenging riddle for the students!

**E:** This riddle can be solved by arranging the nails according to fig.(b) when lying on the table. Then lift this arrangement carefully to the top of the first nail and balance it there. The COG is now lower than the supporting head of the first nail. Thus, a *stable equilibrium* is reached.

### 3.4.5 The COG of a Ruler

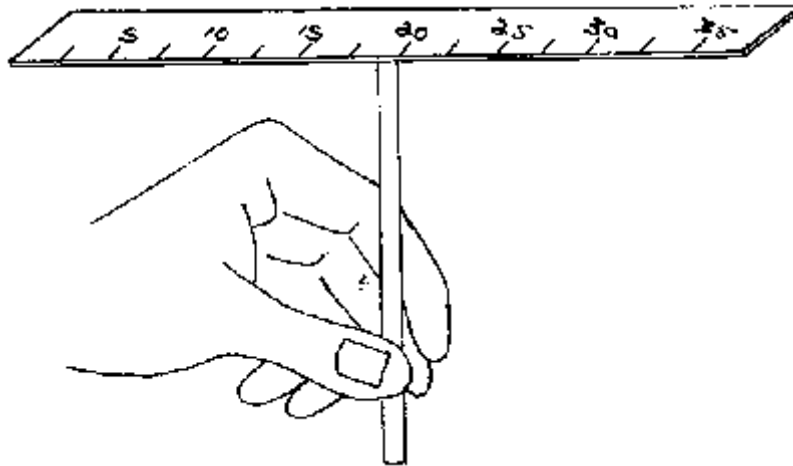

**P:** Find the centre of gravity of a ruler by balancing it on the tip of a pencil.

**Q:** Where does the COG of the ruler lie? Why?

### 3.4.6 Candle Balance

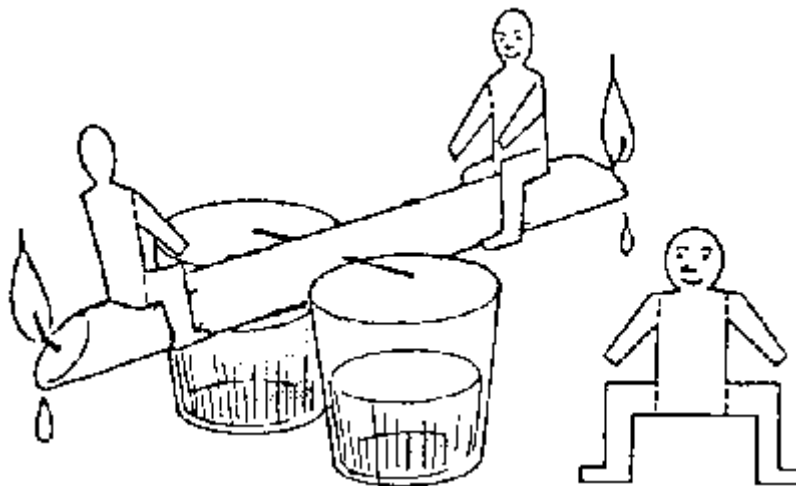

**P:** Construct a candle balance as shown in the figure.

**Q:** What happens? Why?

### 3.4.7 Balancing Coins



**P:** Take two coins and attach two forks to them as shown in the figure. Balance this arrangement on the rim of a jam glass.

**Q:** Why do the coins not fall down?

### 3.4.8 Riddles

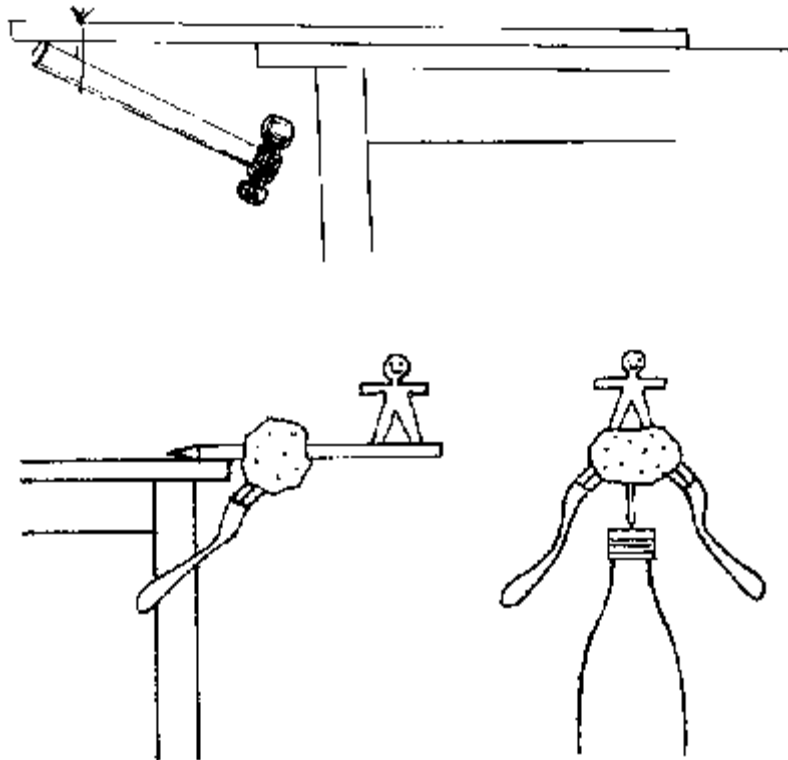

**P:** Produce the arrangements shown in the figures (a) and (b).

**Q:** Why do they not fall down?

### 3.5 The Force of Friction

The force of friction always opposes motion. Friction may be reduced by lubrication. Rolling friction is less than sliding friction. The rougher a surface, the greater the force of friction.

Friction plays an important role in daily life. Without friction we would be unable to start walking.

Any woven material would decompose because it is held together by friction of the threads only. However, we have to reduce friction in the bearings of moving parts of vehicles and other machines in order to save fuel.

#### 3.5.1 Friction Produces Heat



(a)

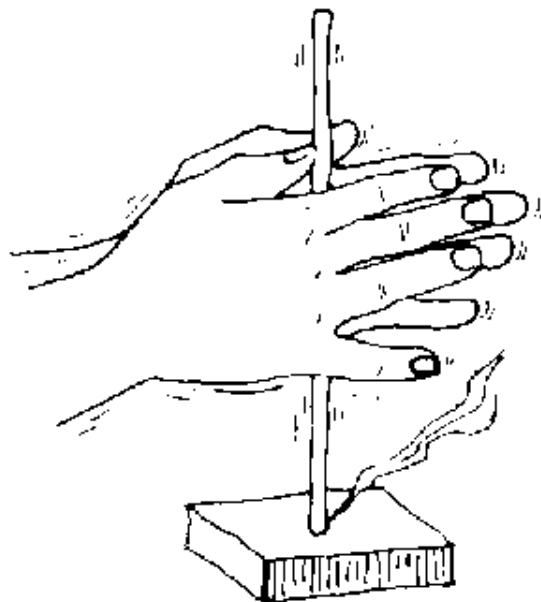

(b)

**P:** Rub your hands.

Turn a stick very quickly between your hands and press its tip onto a piece of wood.

**Q:** What do you feel on your hands?

What do you observe on the piece of wood?

How do you explain this?

**O:** The hands become warm, the piece of wood starts smoking and finally burning.

**E:** Friction produces heat which can light wood if great enough.

**A:** Lighting a fire without matches.

### 3.5.2 Friction and the Kind of Surface

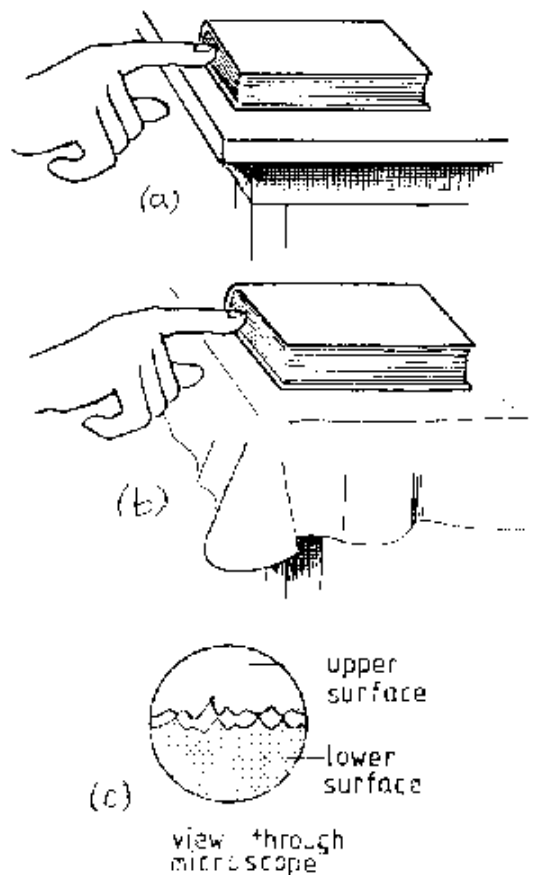

**P:** Pull a book on a bare table surface and then on a piece of cloth.

**Q:** On which surface is it harder to pull? How does the force of friction compare on the two surfaces? How can we explain friction?

**O:** It is harder to pull the book on the cloth than on the bare surface of the table.

**E:** The rougher the surfaces are which slide on each other, the greater the force of friction is. The "mountains" and "valleys" of the surfaces tooth and hence cause the force of friction, see figure (c).

### 3.5.3 Lubrication

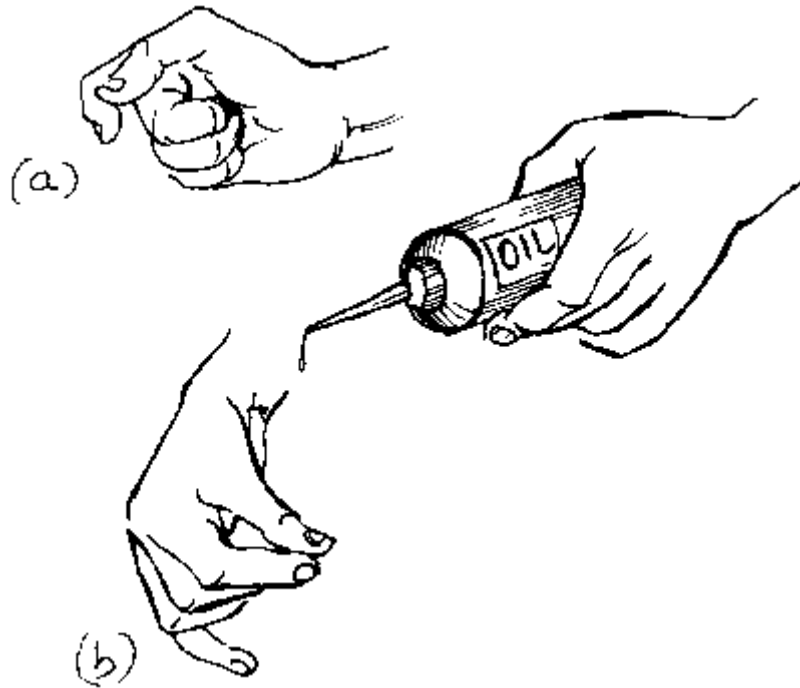

**P:** Rub your thumb and a finger together. Then place a drop of cooking oil or margarine on your thumb and repeat rubbing.

**Q:** How do the forces of friction (needed for the rubbing) compare in the two cases? Hence, what can be done to reduce friction?

**A:** Lubrication of bearings etc. to reduce friction.

### 3.5.4 Rolling and Sliding Friction

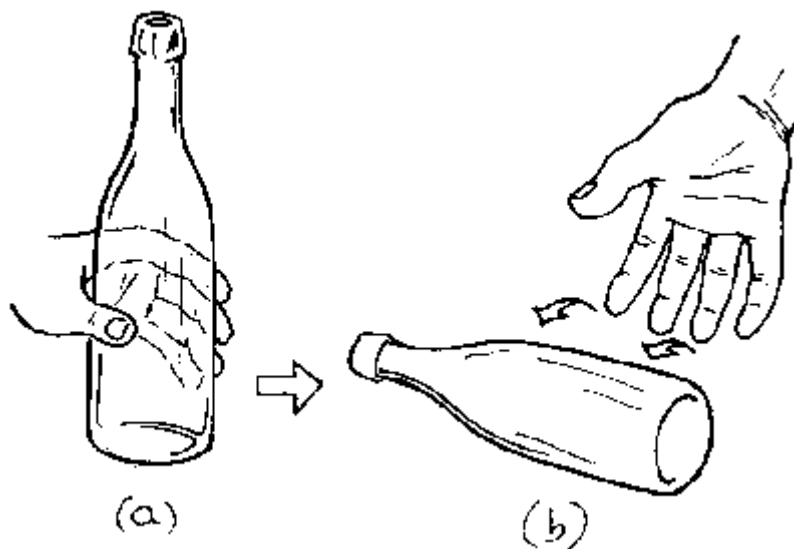

**P:** Slide a bottle or tin and roll it.

**Q:** How are the forces of friction in each case?

### 3.5.5 Rolling Friction

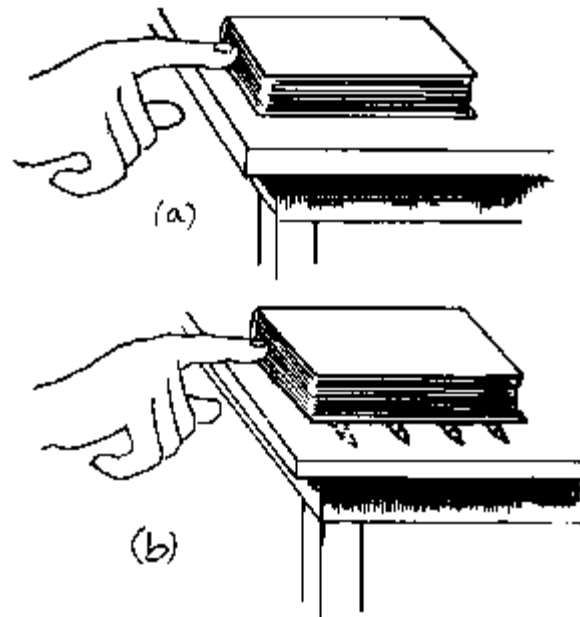

**P:** Pull a book over a table. Put some round pencils or drinking straws between the book and the table.

**Q:** How do the forces of friction compare now?

**A:** Roller bearings, ball bearings.

### 3.5.6 Where Friction is Needed



**P:** Ask students to draw the figure on a display chart.

**Q:** Why does the car *not* move even though the wheels turn?

**E:** There is not enough friction between the tyres and the road to get the car moving.

### 3.6 Density

The density of a substance tells us which mass the unit volume of that substance has got. Thus, it is defined as follows:

$$\text{Density} = \frac{\text{mass}}{\text{volume}}$$

For any pure substance the density is constant at constant temperature and pressure.

Hence, density may be used to identify substances.

#### 3.6.1 The Density of a Solid

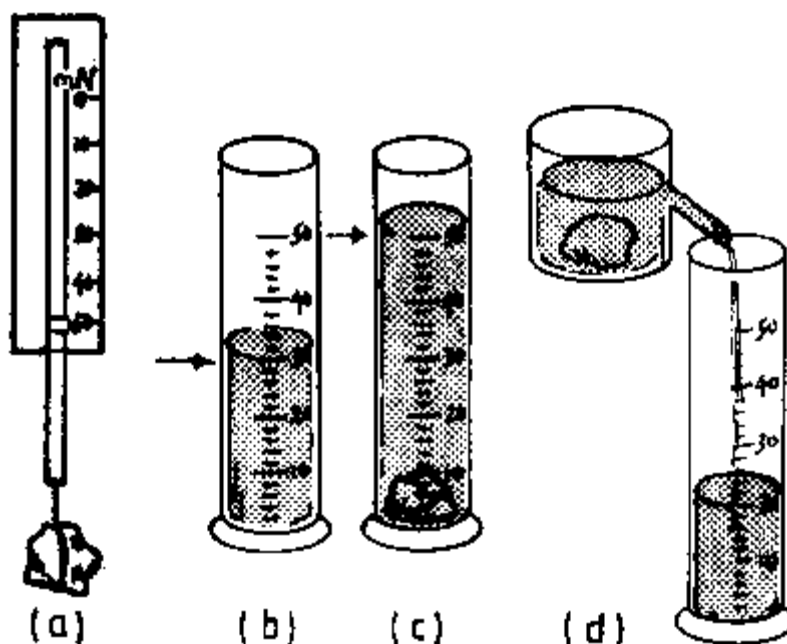

**P:** Attach a stone to a thread and determine the weight of the stone using a Newton balance, see fig.(a). Calculate the mass of the stone. Fill a measuring cylinder partly with water and record the volume, see fig.(b). Now immerse the stone fully in the water and record the new volume, see fig.(c). The difference in volume gives the volume of the stone. Alternatively, you can produce an overflow can from a tin using aluminium foil to make the overflow pipe, see fig.(d). Make the joint of pipe and tin water-tight using glue. Now calculate the density of the stone.

**E:** Assume that the stone has a weight of 0.5 N. Then its mass is

$$0.5 \text{ N} \div 10 \text{ N/kg} = 0.05 \text{ kg} = 50 \text{ g}$$

(Of course, the mass could be measured using a beam balance.)

Assume that the volume of the water displaced by the stone is  $20 \text{ cm}^3$ . Then the density of the stone is

$$50 \text{ g} \div 20 \text{ cm}^3 = 2.5 \text{ g/cm}^3$$

**A:** The determination of density can help to identify a certain substance, e.g. to answer the question: "Is a certain ring really made of gold?"



### 3.6.2 The Density of a Liquid

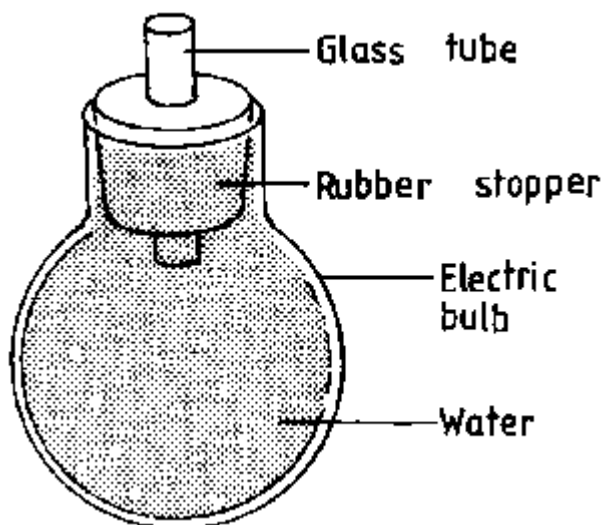

**P:** Prepare a density bottle from a worn out electric bulb fitted with a rubber stopper. Weigh the bulb with its stopper in air, then weigh it when filled with water and then when filled with liquid A, whose density is required. Determine the respective masses. You may use the beam balance described on p. 10.

**Q:** Determine the mass of the water and of the liquid. Calculate the volume of the density bottle and the density of liquid A.

**E:** E.g: Mass of empty density bottle = 15 g

Mass of density bottle with water = 68 g

Mass of density bottle with liquid A = 45 g

Then: Mass of the water = 68 g - 15 g = 53 g

Thus: Volume of density bottle = 53 cm<sup>3</sup>

Mass of liquid A = 45 g - 15 g = 30 g

Thus: Density of A = 30 g ÷ 53 cm<sup>3</sup> = 0.56 g/cm<sup>3</sup>

**H:** Be very careful when opening the worn out bulb, see appendix.

### 3.7 Pressure in Liquids and Gases

The pressure in liquids and gases is caused by their weight. It is defined as follows:

$$\text{Pressure} = \text{force} \div \text{area}$$

The laws of pressure govern many technical devices like barometers, manometers, pumps, etc.

### 3.7.1 What is Pressure?

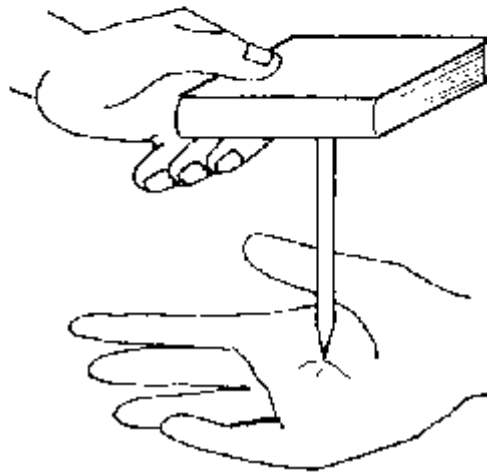
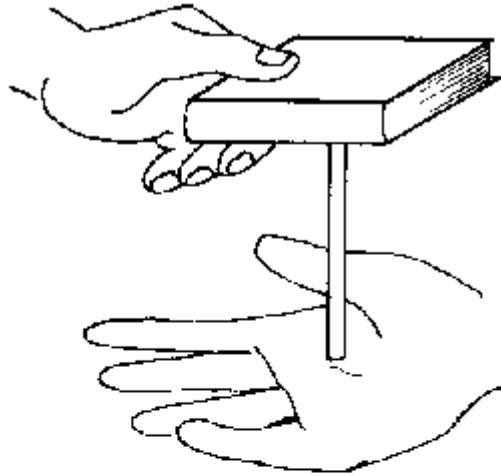

**P:** Ask a student to support a book as shown in figure (a). Then turn the pencil upside down as shown in figure (b).

**Q:** What will the student feel? Why?

**O:** In case (b) the student will feel pain on the hand supporting the pencil.

**E:** In case (b) the force with which the pencil acts on the hand is the same (equal to the weight of book plus pencil) as in case (a) but the pressure on the hand has increased very much since the area on which the pencil touches the hand has decreased so much. Hence, the students will understand that  $\text{pressure} = \text{force} \div \text{area}$ .

**A:** Large area feet of elephants; wide tyres of tractors; wide chains of caterpillar machines.

### 3.7.2 Liquid Pressure Increases with Depth

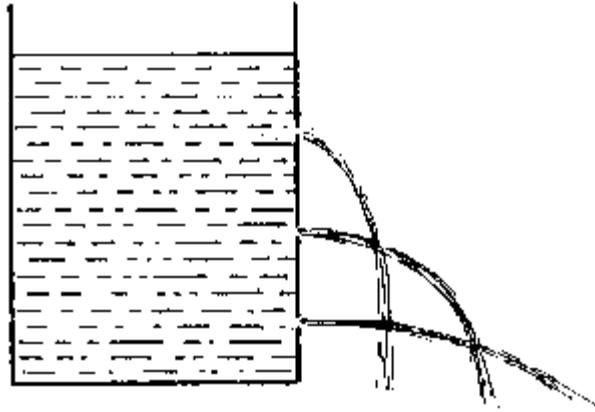

**P:** Pinch 3 holes into a tin according to the figure. Fill the tin with water up to its rim. What do you observe?

**Q:** How does the pressure change with the depth of the water? Why?

**O:** The water shoots the faster out of a hole, the greater the depth of that hole from the surface of the water in the tin.

**E:** The increasing speed of the water from the top to the bottom holes shows that the water pressure increases with the depth of the water. This is so because the weight of the water on top of a certain water particle acts on that particle causing pressure.

### 3.7.3 Carrying a Load on the Head

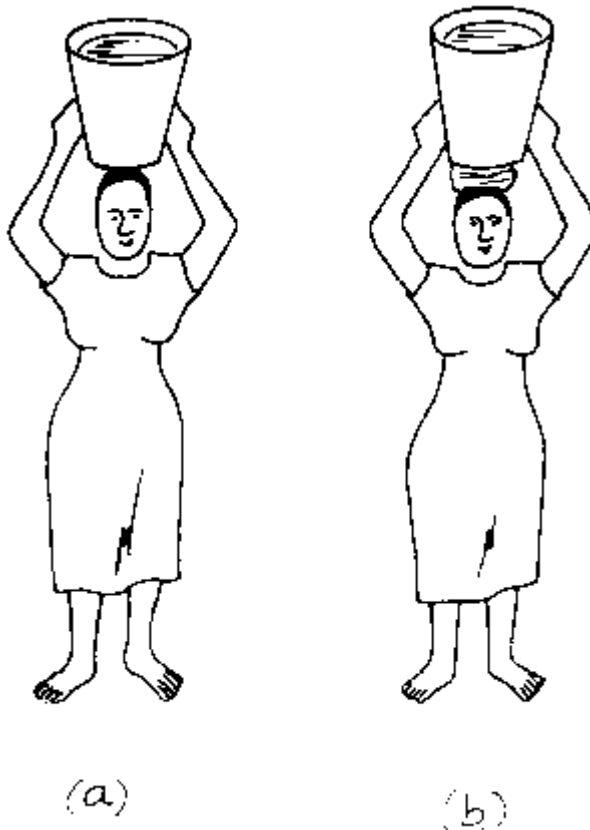

**P:** Carry a bucket of water on your head without (fig. a) and with a "ngata" (fig. b).

**Q:** What difference do you feel? Why?

### 3.7.4 Liquid Pressure Acts in All Directions

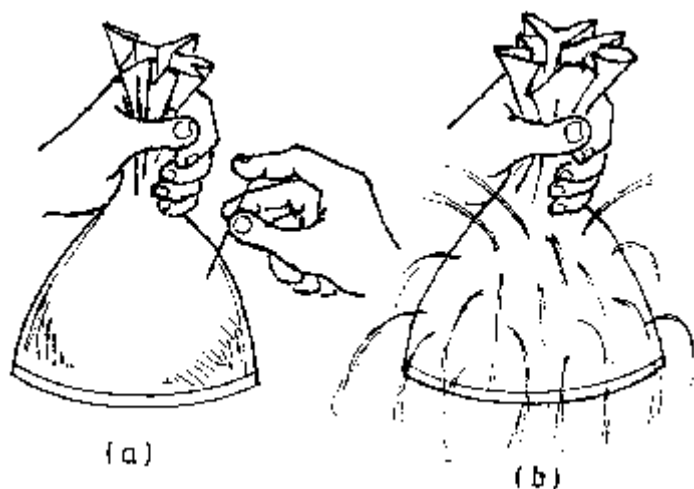

**P:** Pinch some small holes into a plastic bag using a needle. Fill it with water and squeeze the bag gently.

**Q:** In which directions does the pressure of the water act? Why?

**O:** The pressure acts in all directions.

**E:** The particles of a liquid can easily move behind each other while those of a solid are in fixed positions (see chapter 4.2).

### 3.7.5 Air Pressure: The Crashing Can

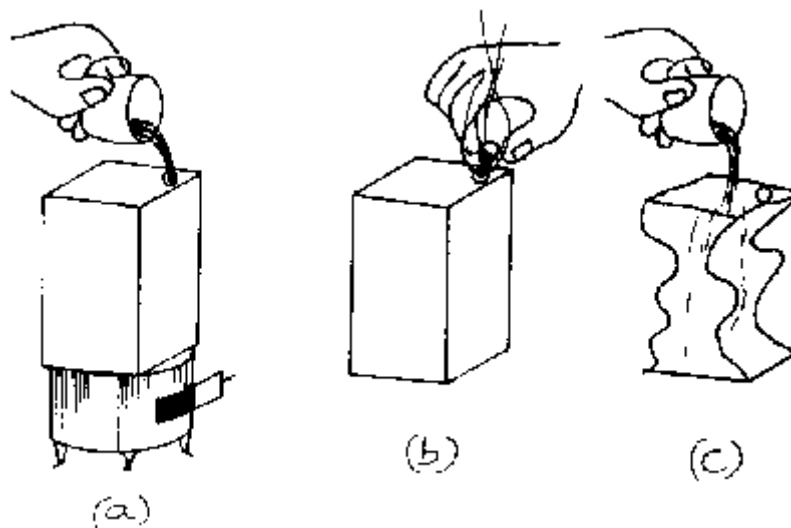

**P:** (a) Fill one cup of water into the large tin can. Then heat the *open* can to boiling.

(b) Remove the can from the fire and close it *immediately* air-tight.

(c) Now pour cold water on the can.

**Q:** What happens? Why?

### 3.7.6 Air Pressure

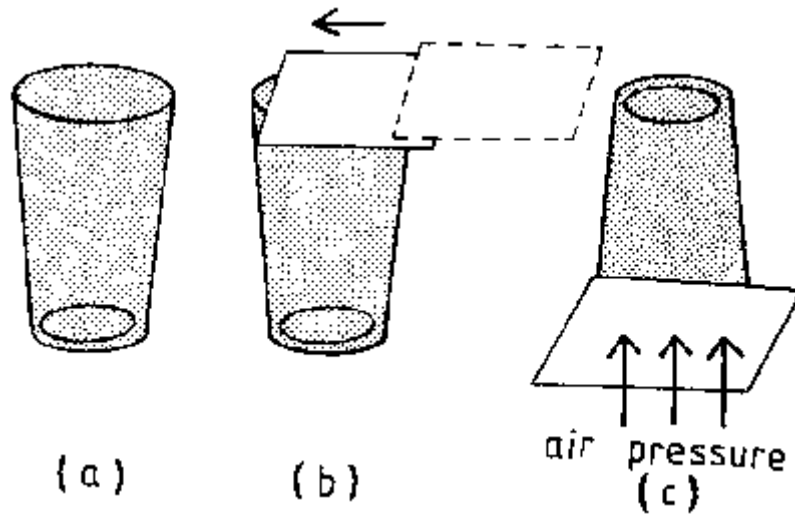

**P:** Fill a drinking glass up to the rim with water. Then push a smooth card or a sheet of smooth plastic from the side to close the glass so that no air bubbles are included. Then turn the glass upside down.

**Q:** Why will the card not fall off?

### 3.7.7 A Barometer

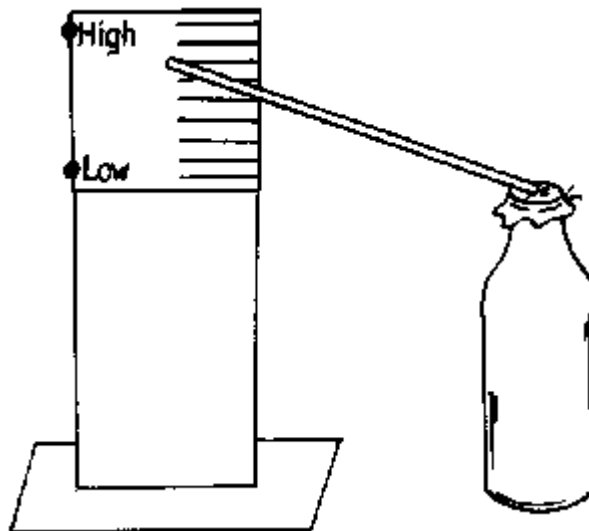

**P:** Assemble a barometer by closing a bottle *air-tight* by using a piece of plastic bag and a string. Glue the straw onto the middle of the piece of plastic and point the straw to a scale (see fig.)

**Q:** How does this barometer work, when the air pressure increases or decreases respectively?

### 3.7.8 A Manometer

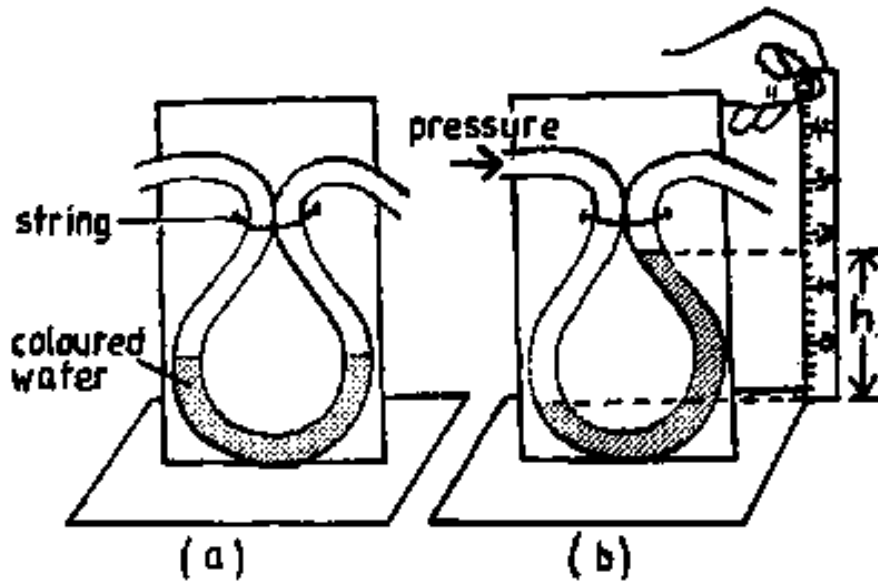

**P:** Make a manometer according to the figure. Use it to measure the water pressure at various depths of the tin of experiment 3.7.2, see p.26.

### 3.7.9 The Siphon

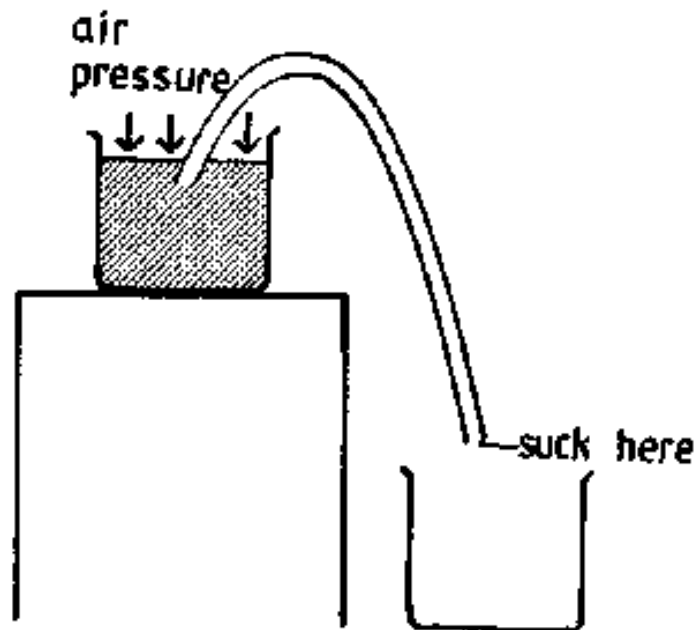

**P:** Arrange two glasses and a plastic or rubber tube as shown in the figure. Suck at the lower end of the tube.

**Q:** What happens? Why?

### 3.7.10 The Syringe

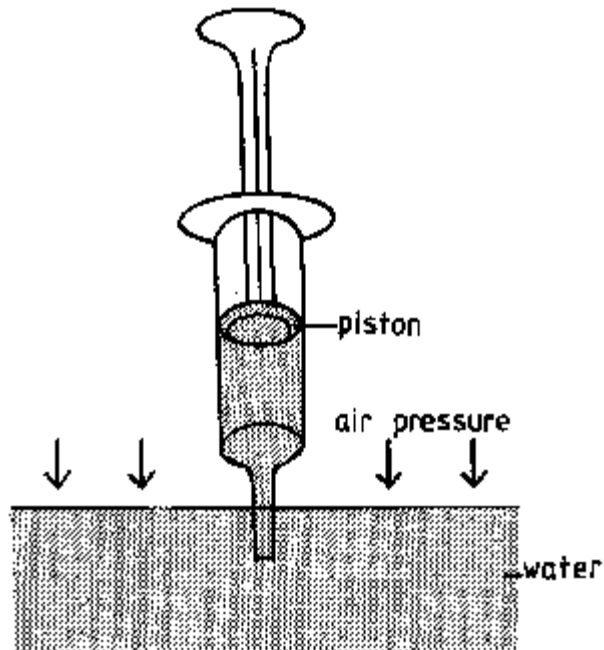

**P:** Obtain a one-way-syringe from a hospital. Suck water in as shown in the figure.

**Q:** Why does the water rise in the syringe?

### 3.7.11 The Bicycle Pump

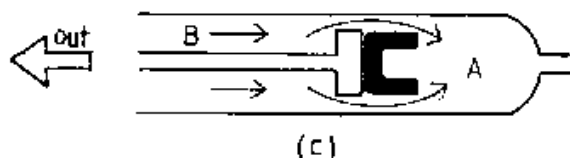
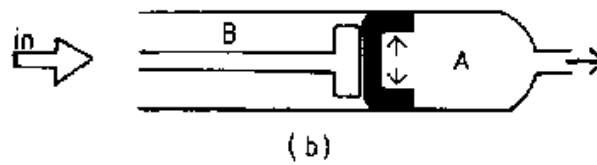
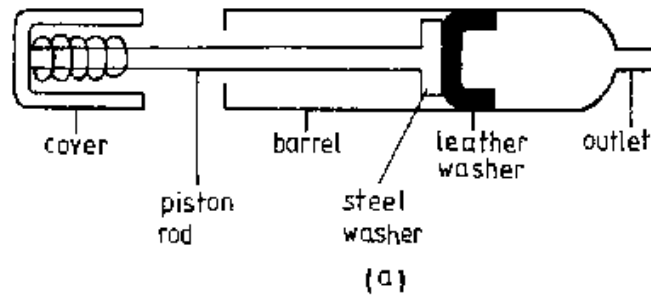

**P:** Using a bicycle pump, pump air into a bicycle tyre. Ask students to draw a display chart of the above figure.

**Q:** Which stroke is easier, the inward or outward one? Why? Explain what happens in these strokes.

**O:** The outward stroke is easier than the inward.

**E:** *Inward stroke* (see fig. b): The air in region A will be compressed, and in turn it will press the leather washer against the barrel to make it air tight. Consequently air will be forced into the tube.

*Outward stroke* (see fig. c): The air in A decreases in pressure. Atmospheric air from B pushes the leather washer inwards and hence enters region A.

### 3.7.12 The Force Pump

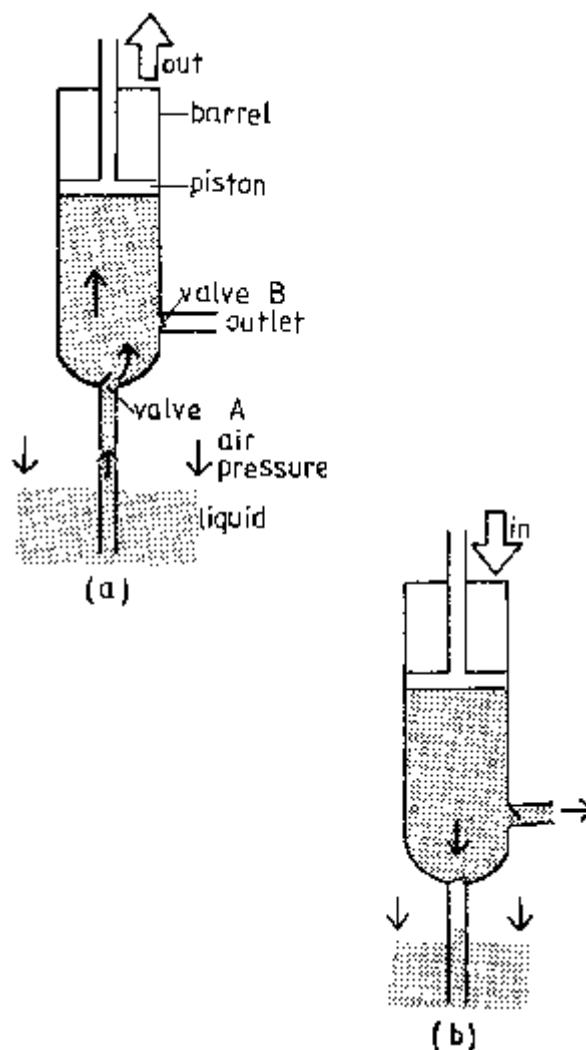

**P:** Ask students to draw a display chart of the force pump according to the above figure.

**Q:** Explain how the force pump works using the display chart.

**E:** *Outward stroke* (see fig. a). When the piston is raised, the liquid pressure in the barrel becomes less than the air pressure. Hence, the air pressure opens valve A and pushes the liquid up into the barrel. It closes valve B.



*Inward stroke* (see fig. b). When the piston is lowered, valve A closes and valve B opens because of the higher pressure of the liquid in the barrel. Consequently the liquid is forced through valve B to the outlet.

**A:** Force pumps are used to pump water from shallow wells in villages. Since the air pressure pushes the water up, the maximum depth from which the water can be lifted is less than 10 m

### 3.7.13 The Lift Pump

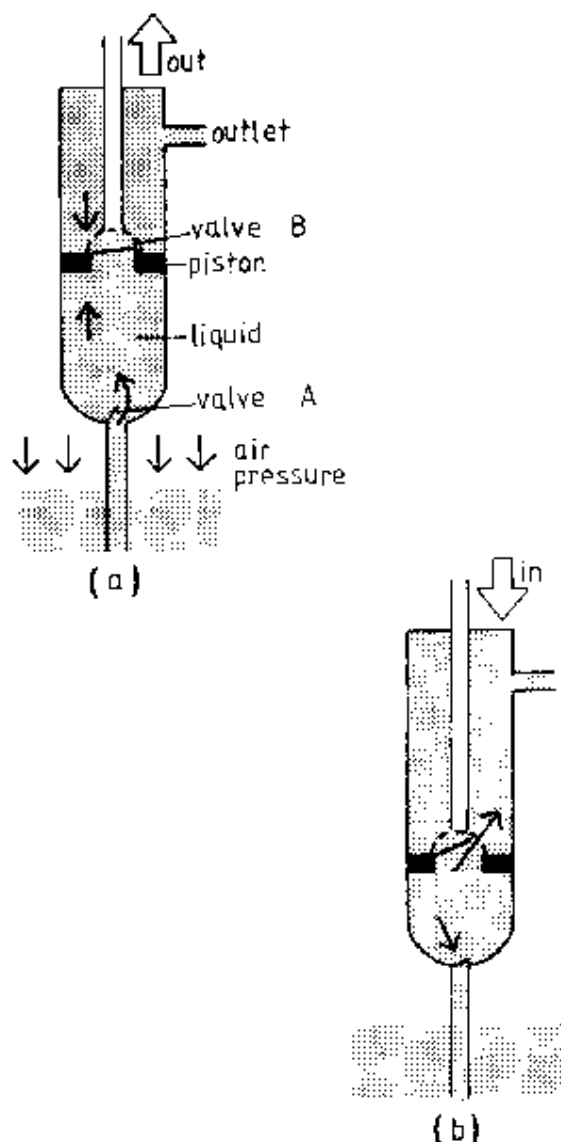

**P:** Ask the students to draw a display chart of the lift pump (see the above figure).

**Q:** Explain how the lift pump works using the display chart.

**E:** *Outward stroke* (see fig. a): The rising piston pushes the water on its upper side out of the outlet since valve B (on the piston) is closed. At the same time the air pressure pushes the water through the open valve A up the barrel.

*Inward stroke* (see fig. b): When the piston goes down, valve B opens and water flows from below to the top of the piston, while valve A is closed.

**A:** The lift pump is used to raise liquids from containers, e.g. tanks of kerosene etc.

### 3.7.14 The Hydraulic Press

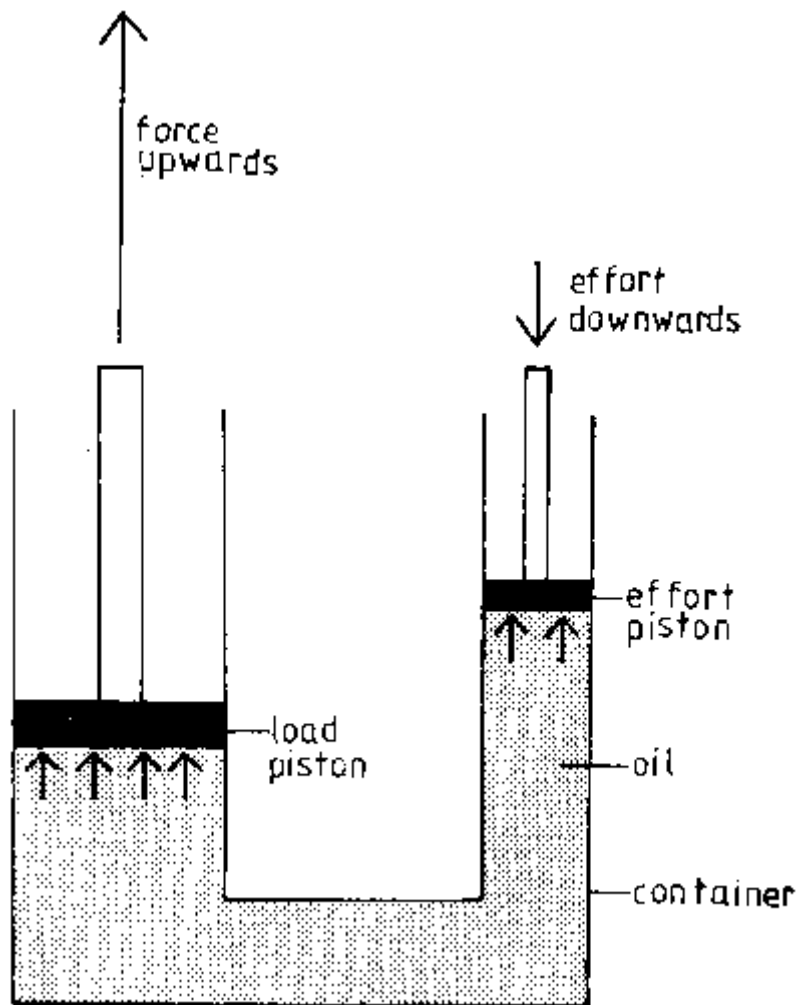

**P:** Ask the students to draw a display chart of the hydraulic press according to the above figure.

**Q:** Explain - using the display chart - how the hydraulic press works.

**E:** A hydraulic press consists of a container which has one end wider than the other. Load and effort pistons are fitted in its ends respectively. Note that the load piston has a larger surface area than the effort piston.

When the effort piston is forced downwards, the pressure of the liquid, e.g. oil, is transmitted equally in all directions in the whole liquid.

Therefore, the pressure at the load piston is the same as that one at the effort piston. Yet, since  $\text{force} = \text{pressure} \times \text{area}$  and the area of the load piston is greater than that of the effort piston, the force at the load piston is greater than that at the effort piston. Thus, *small effort will raise a big load*. However, the distance moved by the effort will be larger than that moved by the load.

**A:** Hydraulic systems are used in brakes, pressing bales of cotton, lifting heavy loads (e.g. vehicles in garages), etc.

### 3.8 Archimedes' Principle and the Law of Floatation

Archimedes' principle states that the *upthrust* (buoyancy) of a body immersed in a liquid is equal to the weight of the liquid displaced by the body. When a body floats then the weight of the liquid displaced is equal to the weight of the body (Law of floatation).

#### 3.8.1 Upthrust

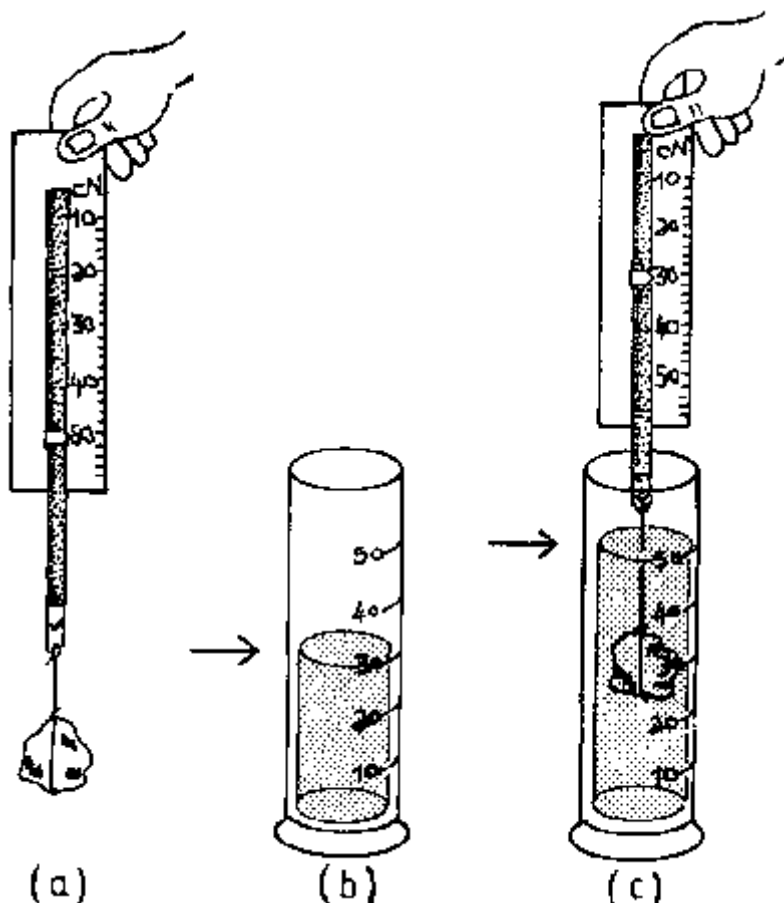

**P:** (a) Attach a stone to a thread, and fix it on a Newton balance (see p. 15). Note the weight of the stone.

(b) Fill a measuring cylinder partly with water and record the reading.

(c) Immerse the stone fully into the water (without touching the bottom of the cylinder) and record the reading of the spring balance. Record the reading of the water level too.

**Q:** How much is the volume of the stone? What is the weight of the water displaced, if  $1 \text{ cm}^3$  of water weighs  $0.01 \text{ N}$ ? By how much did the weight of the stone decrease when it was immersed in the water? What can you conclude about the upthrust?

**O:** For example, let the weight be  $0.2 \text{ N}$ . You observe that the decrease in weight when the stone is immersed is also  $0.2 \text{ N}$ , which is equal to the upthrust.

**E:** Thus, you have verified *Archimedes' principle*.

### 3.8.2 The Law of Floatation

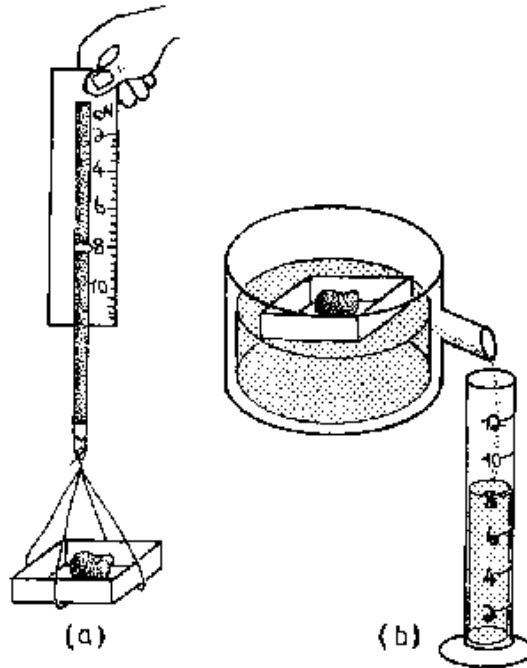

**P:** Load a matchbox with a small stone so that it still floats in water. Weigh the matchbox and stone using a Newton balance to obtain its weight (see p. 15).

Fill the overflow can (see p.25) with water and allow the matchbox with stone to float on it. Let the overflow run into a measuring cylinder. From the volume of the overflow find its weight.

**O:** For example, the weight of stone and matchbox be 0.08 N. Then you will observe that the weight of the overflow will also be 0.08 N.

**E:** Thus, you have verified the *law of floatation*.

### 3.8.3 The Cartesian Diver

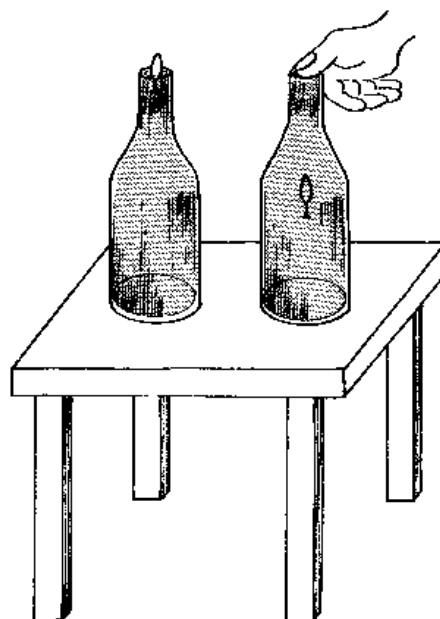

**P:** Fill a bottle to the rim with water. Load a small piece of styrofoam with a small nail so that it just floats in the bottle. This is the "diver". Close the bottle with your thumb airtight and apply pressure.

**Q:** What do you observe? Why?

**O:** According to the pressure exerted by your thumb, the diver will sink or rise.

**E:** Styrofoam has very many tiny pores which are full of air. Thus, when the pressure of the water increases, the air is compressed, its volume decreases, but its mass remains constant. Hence, its density increases, the diver sinks.

When the pressure is released, the air expands, its density decreases, the diver rises.

**H:** Do not allow the diver to stay for a long time in the water. Always remove it immediately from the water when your experiment is finished. Otherwise it will suck in water (since the styrofoam contains capillaries; see exp. 4.4.6, page 51) and sink even without the application of pressure.

### 3.8.4 The Hydrometer

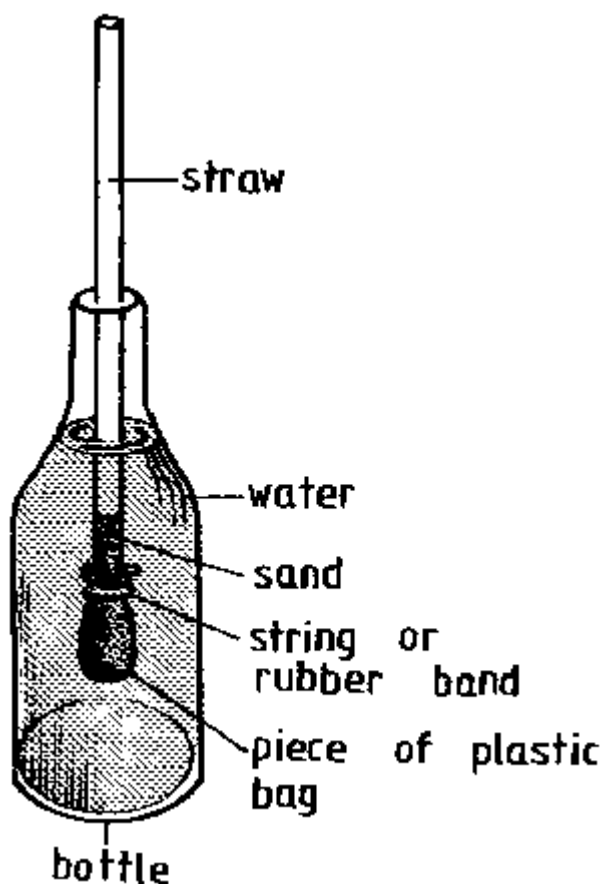

**P:** Prepare a hydrometer by using a drinking straw. Close one end of the straw by wrapping it with a piece of a plastic bag water-tight using a rubber band or a thread.

Fill clean sand into it until it floats in a vertical position in fresh water. Mark the water level on the straw. Label it 1.0 (since water has a density of  $1.0 \text{ g/cm}^3$ ). Take the distance of this mark from the bottom of the straw to be  $x \text{ cm}$ . Now you may put marks for liquids with other densities by calculating their distance 1 cm from the bottom of the straw by using the formula:

$$1 = x \div (\text{density of liquid})$$

For example, if  $x = 9.4$  cm, you calculate the position of the mark for a density of  $0.9 \text{ g/cm}^3$ :

$$1 = 9.4 \text{ cm} \div 0.9 = 10.4 \text{ cm}$$

i.e. you place the  $0.9 \text{ g/cm}^3$  mark at the distance of 10.4 cm from the bottom of the straw, and so on. Place marks from  $0.6$  to  $1.2 \text{ g/cm}^3$ .

**H:** You might have to compress the sand at the bottom of the straw using a stick (or put a nail inside) in order to make it float vertically.

**A:** Use the hydrometer to measure the density of e.g. kerosene, sea water and pure milk. Thus you can discover the wateringdown of milk by measuring its density using the hydrometer.

### 3.8.5 An Egg in Water

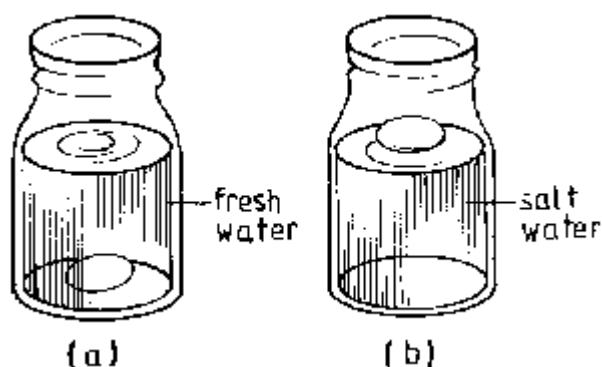

**P:** Place a fresh egg in water. Observe. Now dissolve salt in the water while stirring until the egg floats.

**Q:** Why does the egg float in the salt water?

**E:** The density of salt water is higher than that of fresh water. Thus, the weight of the displaced salt water becomes equal to the weight of the egg. Hence, the egg floats in salt water of a sufficient salt content.

### 3.8.6 The Floating Candle

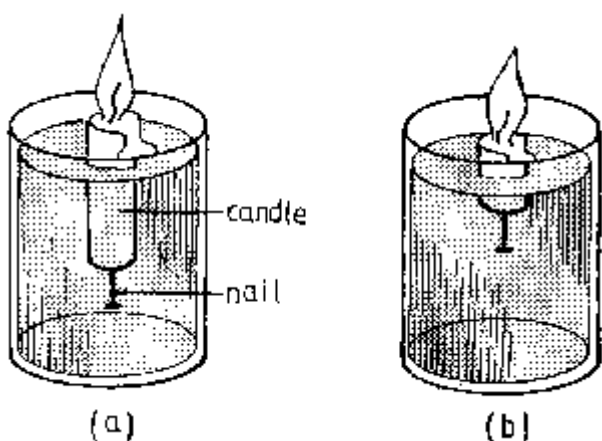

**P:** Put a nail into the bottom end of a candle so that the candle just floats with its top a bit above the surface of the water.

Light the candle and watch it as it burns up.

**Q:** Why does the candle continue to float even though it constantly loses weight as it burns up?

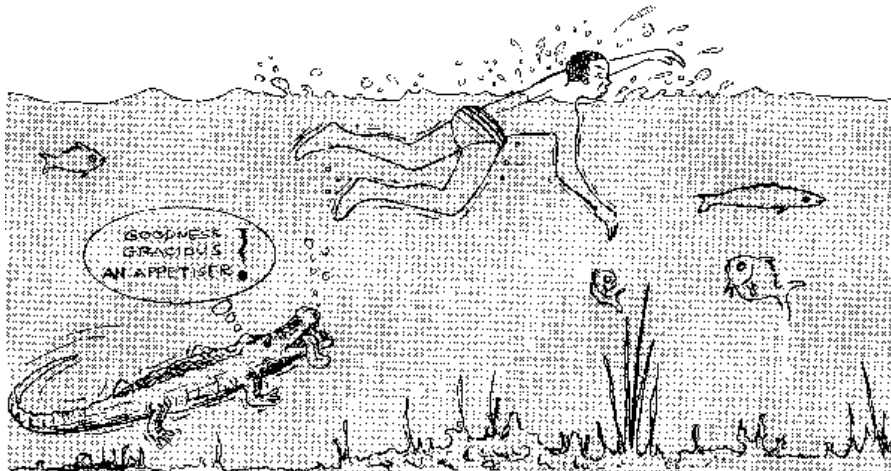

### 3.9 Work, Energy and Power

To pull a heavy cart is tiring work. In physics *work* is defined as follows:

Work done = force x distance moved in the direction of the force.

Unit:  $1 \text{ N} \times \text{m} = 1 \text{ J}$  (joule)

*Energy is the ability of doing work.* Hence, its unit is also 1J.

*Power is the rate of doing work,* i.e. work per unit time. Its unit is  $1 \text{ joule/second} = 1 \text{ watt}$  (1 W)

#### 3.9.1 Work Done by Lifting

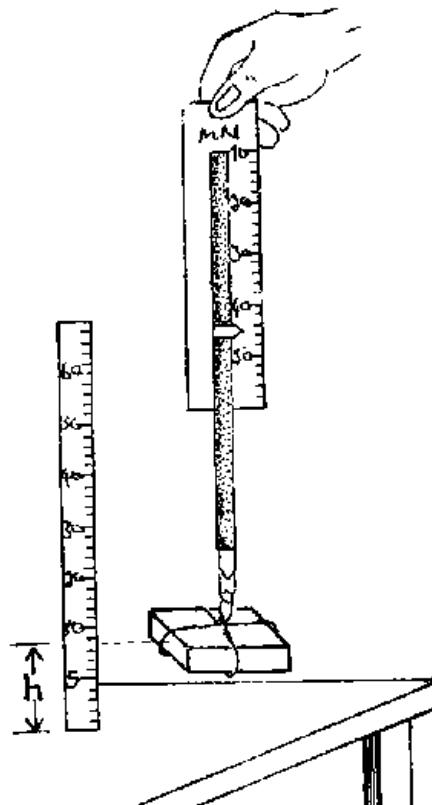

**P:** Raise a block of wood from the table using a Newton balance (see p. 15). Read the balance when you lift the block at *constant* velocity, not when starting or stopping. Compare this force with the weight of the block. Measure the vertical distance the block is raised.

**Q:** Calculate the work done when the block was raised by the vertical distance  $h$ .

**E:** The force which lifts the block at constant velocity is equal to its weight in magnitude but has the opposite direction. Thus, the *work done by lifting* is

$$\text{Work done} = \text{weight} \times \text{vertical distance}$$

### 3.9.2 Work Done by Friction

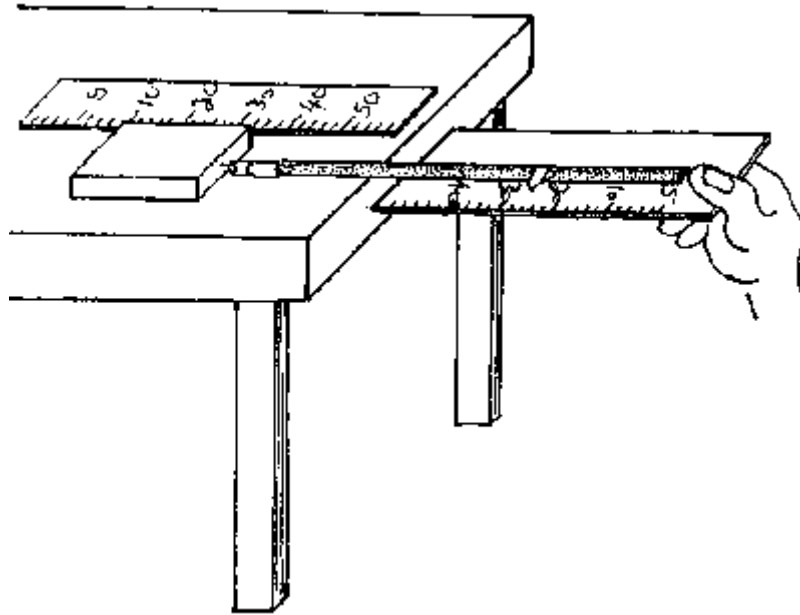

**P:** Place a block of wood on a table. Pull it with constant velocity using a Newton balance. Measure the distance moved by the block.

**Q:** Calculate the work done from the reading of the balance and the distance measured.

**E:** The force which pulls the block at constant velocity is equal to the force of friction in magnitude but has the opposite direction. Thus, the *work done by friction* is

$$\text{Work done} = \text{force of friction} \times \text{distance moved}$$

### 3.9.3 A Catapult

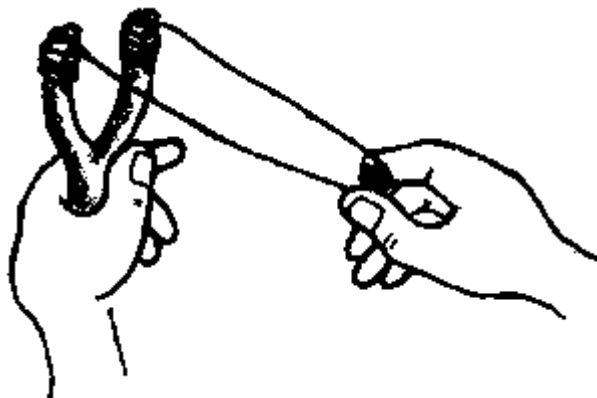



**P:** Tie a rubber band to the ends of a branched stick. Place a stone in the middle of the rubber band and stretch the band by pulling the stone towards you. Then release it.

**H:** Be very careful that nobody will be hit by the stone!

**Q:** What do you observe?

What kind of energy does the stretched rubber band, what the flying stone possess?

### 3.9.4 The Principle of a Steam Engine



**P:** Fill some water into an opened electric bulb (see appendix) and close it *slightly* by a stopper. Then holding it with a strip of paper heat it using e.g. a kerosene burner until the water boils.

**Q:** What happens to the stopper? What energy changes take place?

### 3.9.5 A Pendulum

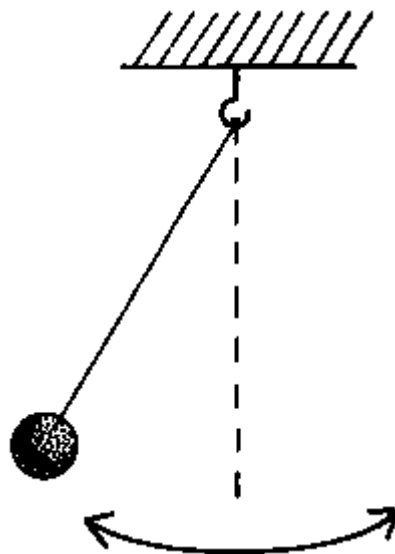

**P:** Suspend a stone on a long string. Displace it sideways.

**Q:** What do you observe? What changes in energy take place?

**E:** When the pendulum is displaced sideways by your hand, *chemical energy* of your food is changed into *potential energy* of the pendulum. When the pendulum swings back, it converts the latter into *kinetic energy* which is changed again into *potential energy* on the other side of the oscillation and so on.

### 3.9.6 Potential Energy in a Clothes-Peg

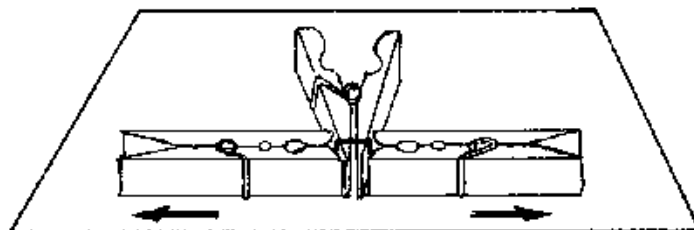

**P:** Tie the handles of a spring clothes-peg together with *one* loop of thread. Place this peg at the middle of a smooth table and place two other pegs beside it, one against each end of each handle. Bum the thread.

**Q:** What do you observe? What changes in energy take place?

### 3.9.7 Energy and the Funny Jumper

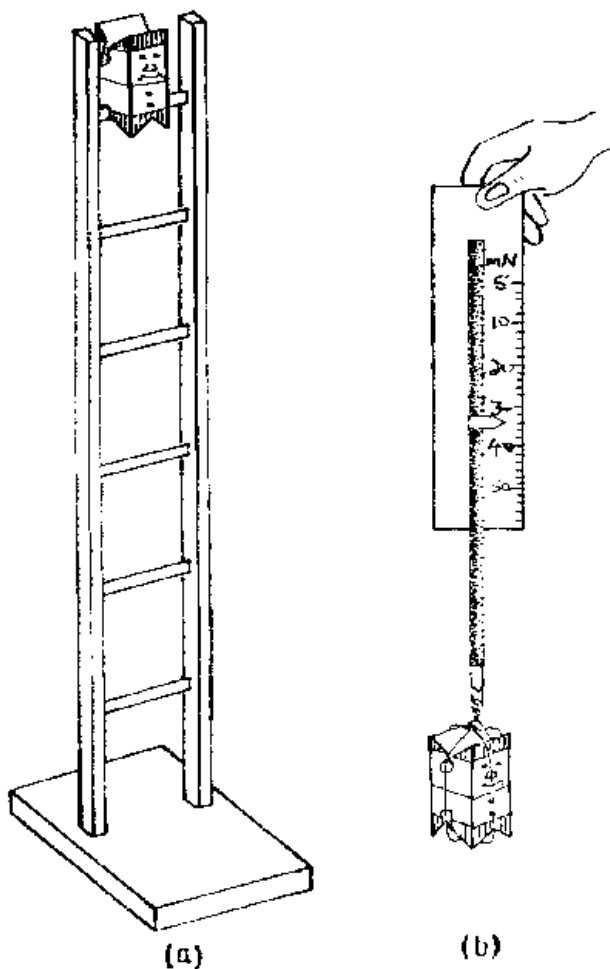

**P:** Set up the funny jumper (see p.21). Weigh the jumper using a Newton balance.

**Q:** Calculate the potential energy of the jumper when it is on the uppermost step of the ladder. Where does this energy go when it jumps down step by step?

**E:** The *potential energy* of the jumper is equal to its weight times the height of the uppermost step above ground. As the jumper jumps down, this energy is converted into *kinetic energy* (energy of motion) which in turn is converted into *heat* by friction.

### 3.9.8 Power

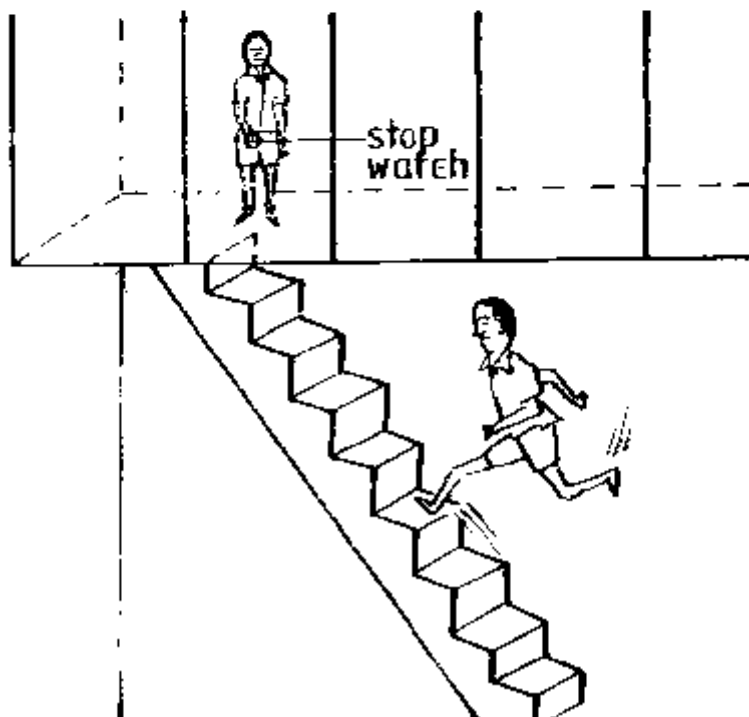
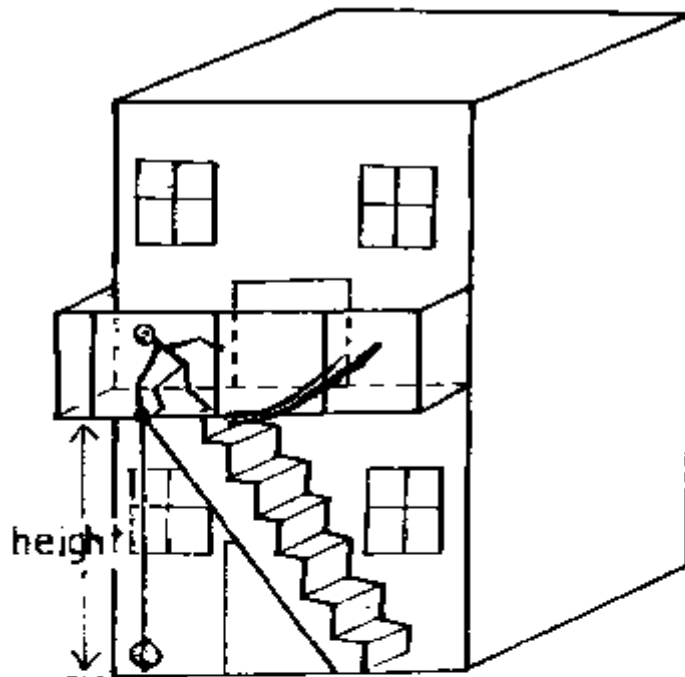

**P:** Measure the vertical height above ground of the first floor of a storey building. Run up to that floor as fast as you can while your friend times you with a watch. Take your weight (probably in a hospital).

**Q:** Calculate your maximum power.

**E:** Using your weight and the height of the first floor above ground, first calculate the potential energy (PE) of your body when it is on the first floor:

$$PE = \text{weight} \times \text{height}$$

This is the energy which you had to give out in order to raise your body to that height.

Now calculate your power by dividing that energy by the time (in seconds) you needed for running up.

### 3.10 Simple Machines

Simple machines use the principles of Physics to give us mechanical advantage, e.g. to *lift a heavy load using a small effort*. Examples are levers, wheel and axle, pulleys, the inclined plane etc.

Mechanical advantage (MA) = load  $\div$  effort. It depends on friction.

Velocity ratio (VR) = distance moved by effort  $\div$  distance moved by load. It does not depend on friction.

Efficiency = output  $\div$  input - work done on the load  $\div$  work done by the effort = MA  $\div$  VR. It depends on friction.

#### 3.10.1 Levers

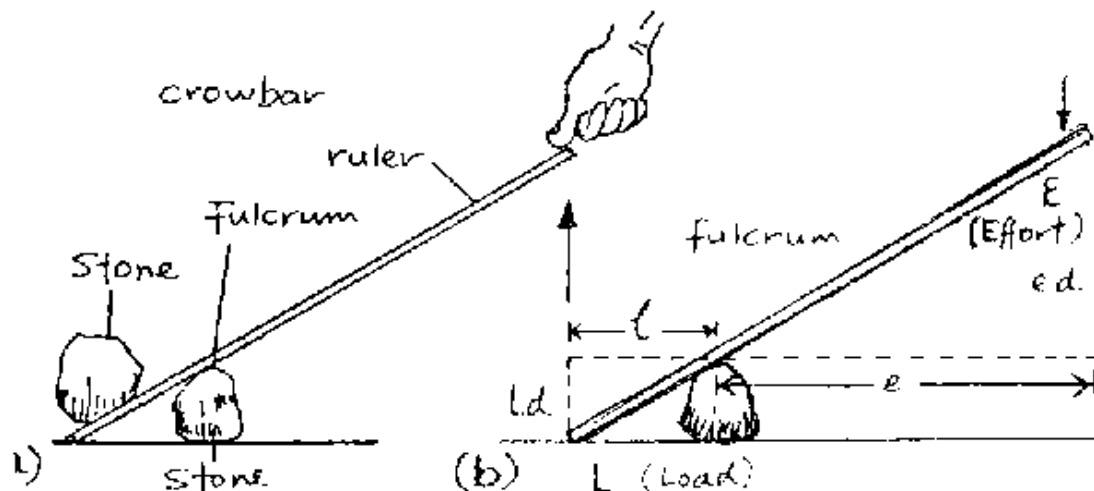

**P:** Make a lever using your ruler and a tipped stone. Use it to lift a heavy stone or brick.

**Q:** Do you feel the mechanical advantage? Derive a simple formula for MA (assuming there is no friction) using moments of forces (see p.20).

**O:** The effort is less than the load but the distance moved by the effort (d.e.) is longer than the distance moved by the load (d.l.).

E: Taking moments of forces (see fig. b) we obtain (neglecting friction):

$$L \times 1 = E \times e$$

A:

$$\frac{L}{E} = \frac{e}{1}$$



The seesaw, pliers, the wheelbarrow, tweezers, the bottle opener, the forearm, the roman steelyard, etc. are all levers.

### 3.10.2 The Roman Steelyard

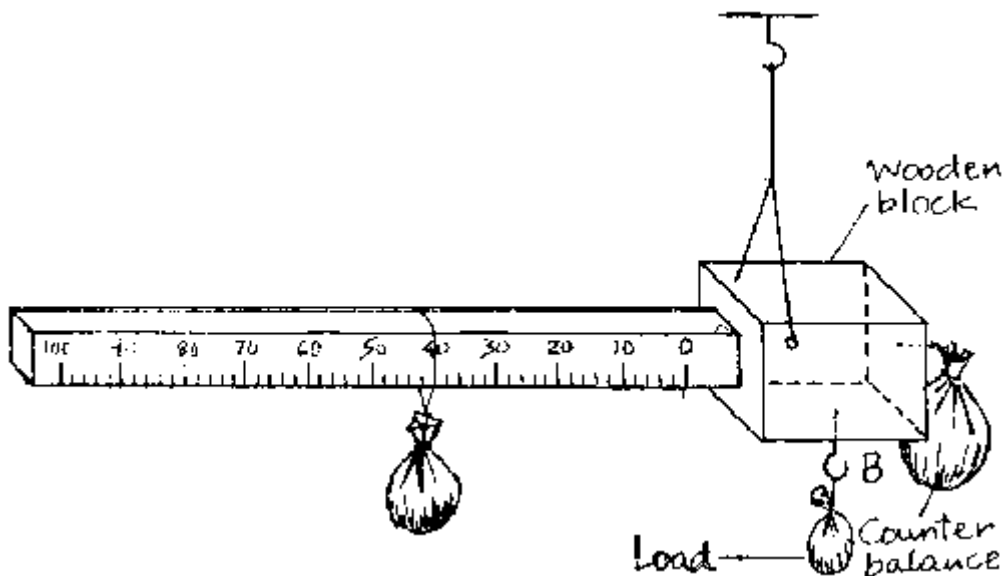

P: Make a roman steelyard according to the figure using wood.

*Calibration:* Suspend the roman steelyard in air. Then suspend e.g. a 100 g mass on the assumed zero mark. Hang a counterbalance mass on the other side (as shown) so that the whole system balances horizontally. Then hang a standard mass, e.g. 50 g on B and adjust the 100 g along the rod so that the whole system balances horizontally. Mark this point for the standard mass used (e.g. 50 g). Repeat this procedure for other masses (e.g. 100, 150, 200 g, ...).

*How to measure an unknown mass (load):* Suspend the load (whose mass you want to determine) from B. Then adjust the 100 g mass along the beam so that the whole system balances horizontally. Read and record the mass of load.

**H:** The whole system should be suspended freely in air and it must be balanced *horizontally* in each step.

**A:** Used in weighing cotton, bags of coffee etc.

### 3.10.3 The Single Pulley

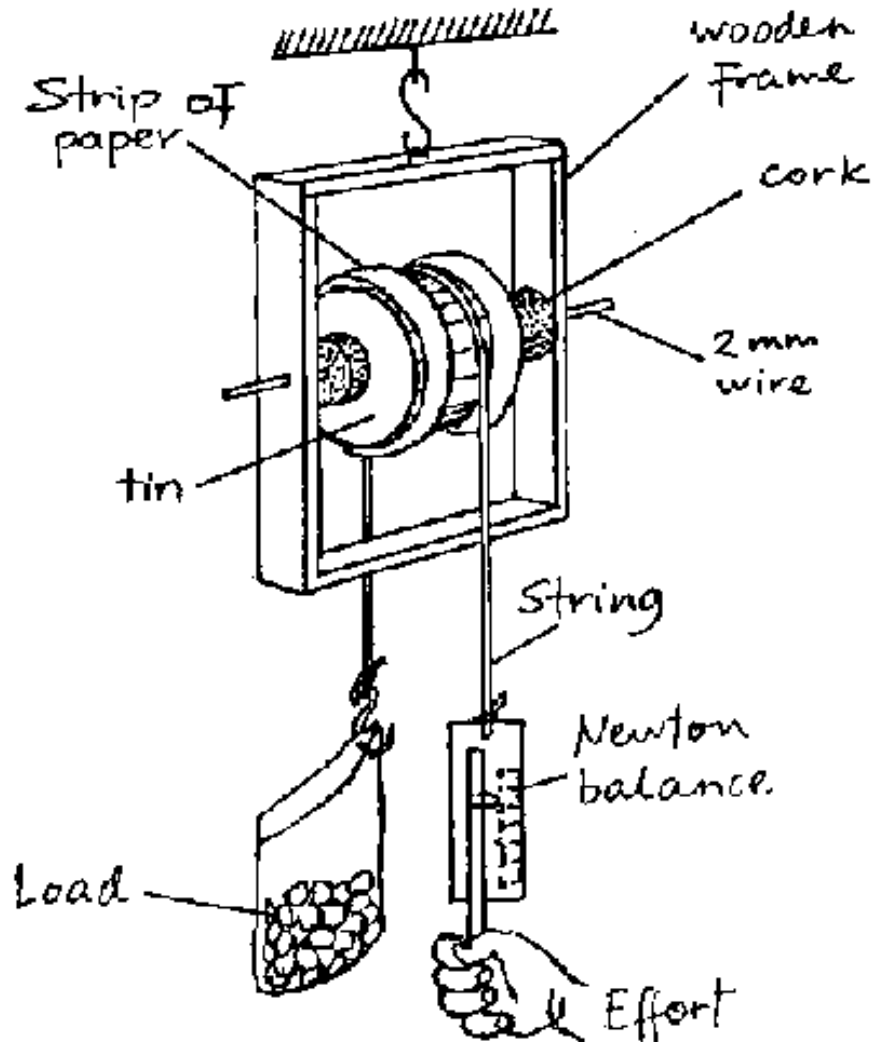

**P:** Produce a pulley by boring holes in the centre of the top and the bottom of a small tin. Take a wire of 2 mm diameter as an axle and fix it in a wooden frame as shown in the figure. Attach strings and use it to lift a load (which should be much heavier than the pulley). Use a Newton balance to measure load and effort.

**Q:** What is the MA of the simple pulley? What is the advantage of it?

**E:** A single pulley has an MA of 1, i.e. the effort is as big as the load is (including friction it is even bigger). Yet, the advantage is that the pulley *changes the direction* of the force. You can easier lift a heavy load by pulling downwards (assisted by your weight) than by pulling upwards.

### 3.10.4 The Two Pulley System

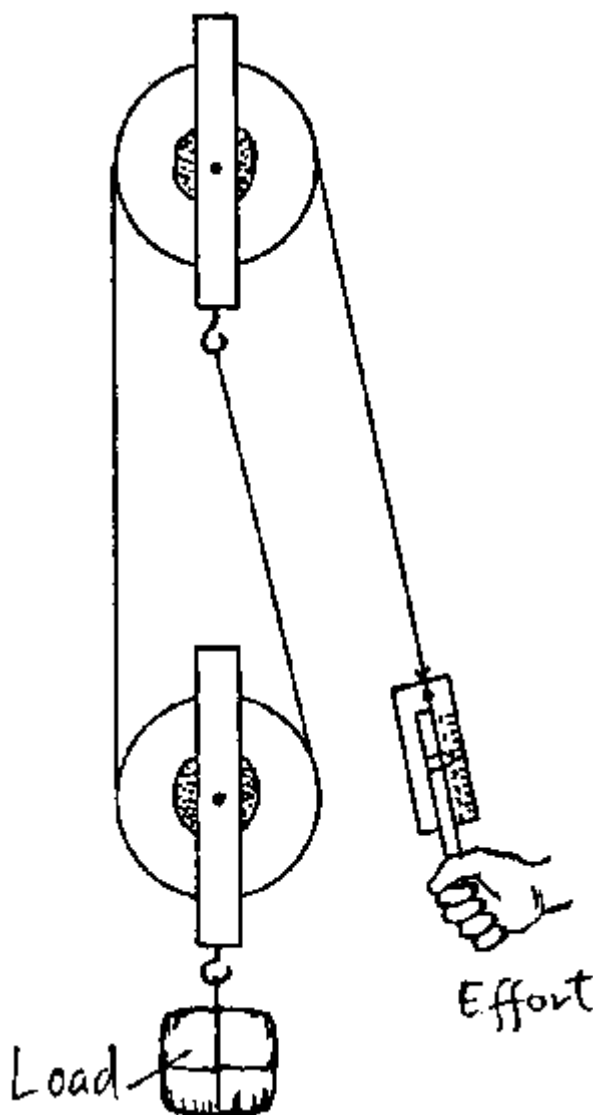

The two pulley system is the simplest *block and tackle* which gives a real MA when used to lift heavy loads.

**P:** Connect two single pulleys as shown in the above figure. Use this system to lift the same load as in experiment 3.10.3. Measure the effort using a Newton balance.

**Q:** What do you feel when lifting the load directly and when using this pulley system? How is the MA now (if you neglect friction and the weight of the lower pulley)? How far does the effort move, when the load moves, e.g. a distance of 20 cm?

**O:** It is easier to lift the load using this system: the effort is smaller.

**E:** Neglecting friction and the weight of the lower pulley, the MA will be 2, i.e. the load is twice the effort. However, in practice it is less due to the factors mentioned.

The effort moves 40 cm when the load moves 20 cm.

**A:** Cranes (e.g. in harbours) use (even more complex) pulley systems to lift very heavy loads.

### 3.10.5 A Riddle

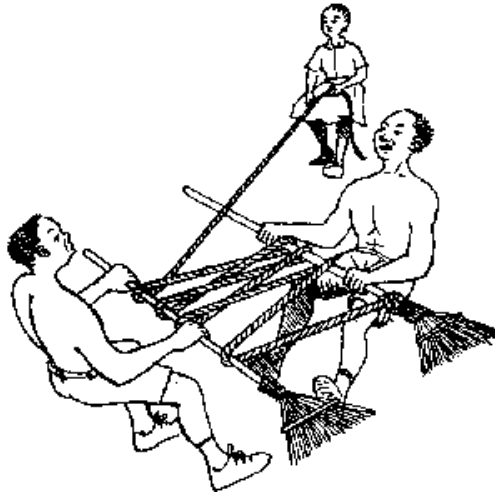

**P:** Ask two strong boys and a girl to take two (broom) sticks and a rope and to arrange themselves as shown in the figure.

**Q:** Will the girl be able to pull the two strong boys together or can the boys resist the pull of the girl?

**O:** The girl wins. Why?

**E:** This is an arrangement of "broomstick pulleys". Thus, the girl needs much less effort to pull the heavy loads of the two boys! However, the girl will have to move farther than the boys do.

### 3.10.6 The Inclined Plane

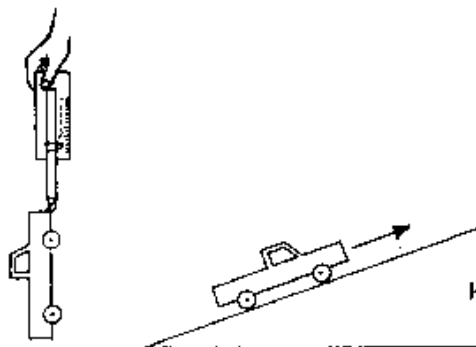
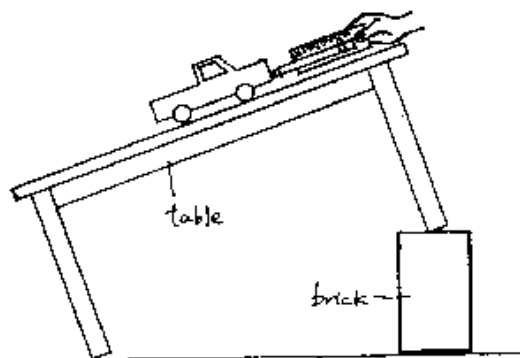



**P:** Tilt a smooth table by placing bricks underneath its legs on one end of the table (see fig. a). Ask students to bring their toy cars.

Weigh a toy car using a Newton balance. Now pull this toy car up the inclined plane of the table using a Newton balance to measure the effort.

**Q:** Is the effort smaller than the load (weight of the toy car)? How is the velocity ratio = (distance moved by effort along the slope) ÷ (distance moved by the load *vertically*)?

**E:** The effort is smaller than the load. The MA depends on the inclination of the plane as does the VR which is greater than 1.

**A:** Hills, slopes and ramps are examples of inclined planes, screws apply the same principle. The Egyptians used inclined planes to build their pyramids as people do sometimes nowadays to carry the building materials when building a two or three storey house.

### 3.11 Astronomy - The Solar System

Astronomy is the study of bodies in the universe and of their motion, e.g. the study of the solar system. The sun has nine planets going around it. The planets differ in size and relative distances from the sun. They are kept in their almost circular paths by the *gravitational force* of the sun which acts as *centripetal force*.

#### 3.11.1 Model of Sun-Earth-Moon

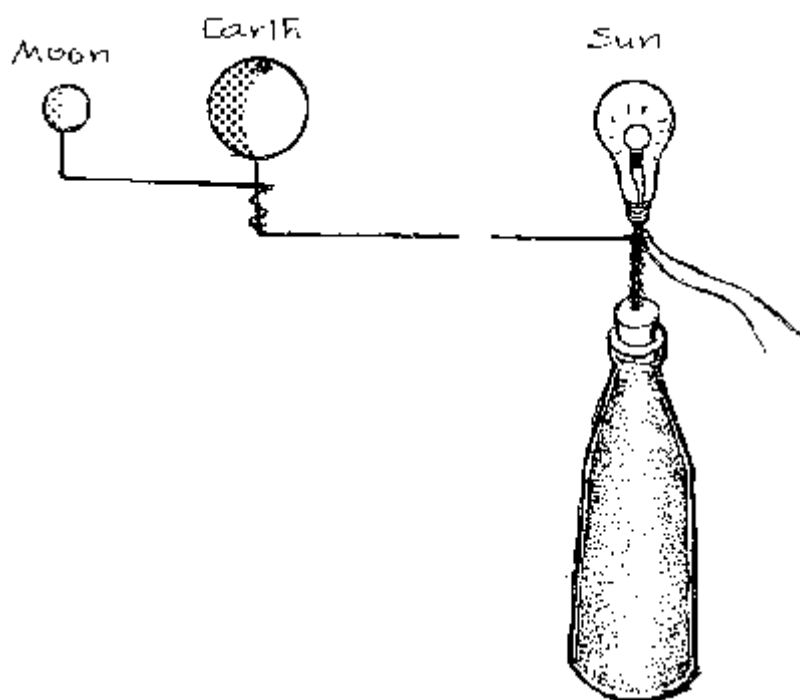

**P:** Pierce a seed and a small fruit with wires. Join an opened bulb (see appendix) to a bottle filled with sand using a wire. Join the three wires so that they allow rotation. The seed, fruit and bulb represent moon, earth and sun respectively. The bulb may be lit using a torch bulb and battery.

**E:** The model can be used to show the movement of the earth and the moon around the sun and earth respectively. It can also show the eclipse of the moon and the sun, when the earth shades the moon or the moon shades a part of the earth respectively.

### 3.11.2 Centripetal Force

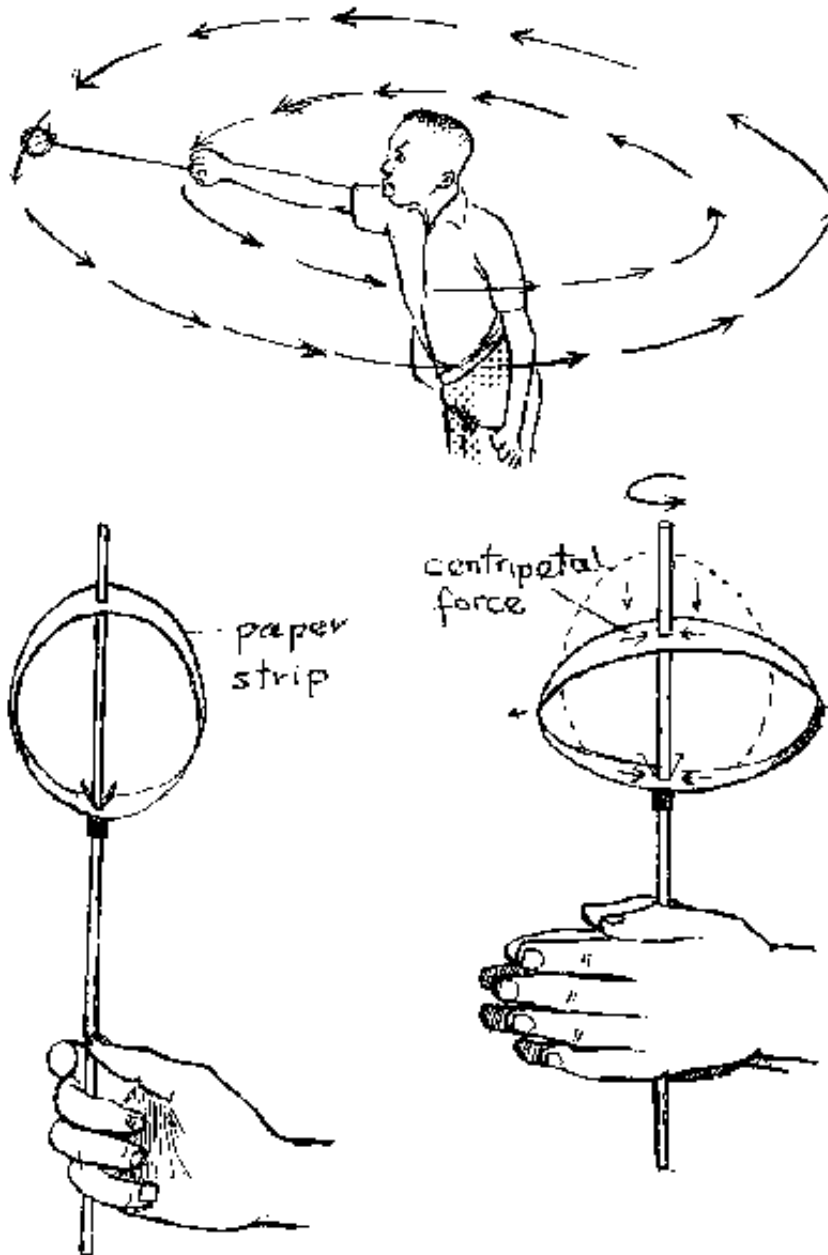

Due to its inertia a body will move along a straight line when *no* force acts on it. What force keeps the planets on their circular paths?

**P:** Tie a ball or stone to a thread and whirl it around as shown in the above figure.

**Q:** What force keeps the stone on its circular track?

**E:** There acts a force along the thread (which you feel in your hand) called the *centripetal force* which forces the stone to the circular path. Thus, a centripetal force must also act on each planet to keep it on its circular path.

### 3.11.3 Demonstrating the Solar System



**P:** Place a chair at the centre of the football field of your school to represent the sun. Now ask nine students to go around the chair in circles to represent the planets. The radius of each circle should correspond to the distance of the respective planet from the sun.

For example, if you use a scale of 1 cm representing a distance of 1 million km from the sun, then (see the table below) the radius of the mercury path must be 58 cm, that of the venus 107 cm, that of the earth 149 cm and so on. (Of course, in this scale, the sun would be a ball of 2 cm diameter, the earth only a grain of sand).

**Q:** What will be the radii of the paths of Jupiter, Uranus and Pluto respectively in this model?

**E:** They will be 7.8 m, 28.5 m and 58.7 m respectively.

Planet	Distance in millions of km from sun
Mercury	58
Venus	107
Earth	149
Mars	227
Jupiter	773
Saturn	1418
Uranus	2853
Neptune	4469
Pluto	5866

### 3.11.4 Gravitational Force

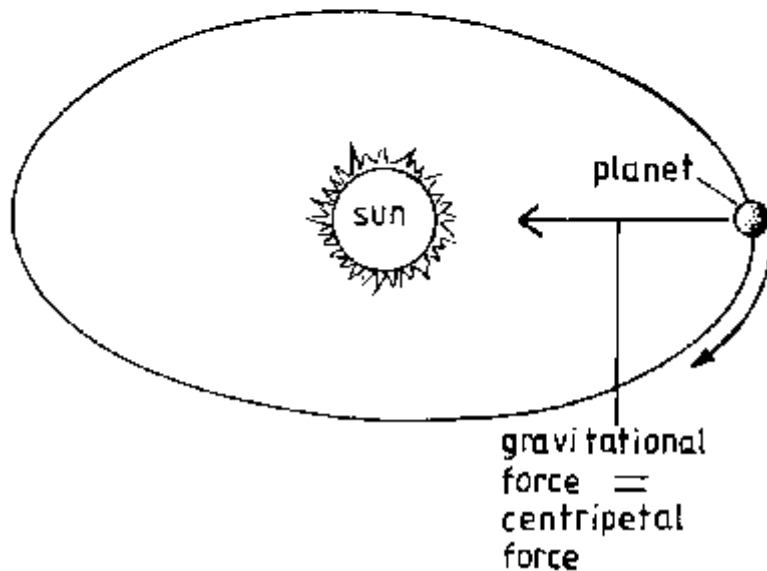
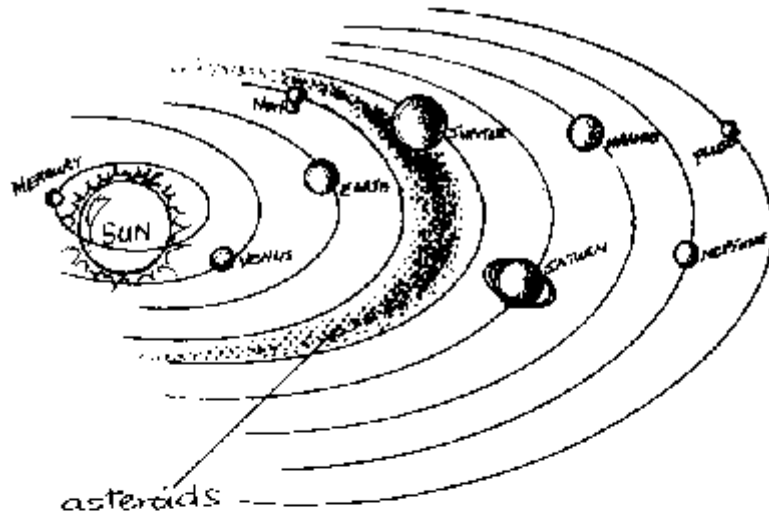

How do we call the force which acts as the centripetal force for the planets? Obviously, the planets are not tied to the sun by a string as the stone in experiment 3.11.2 is tied to your hand.

There must be a force acting through the empty space tying the planets to the sun. This force is the pull of the mass of the sun on the mass of the respective planet. It is a force of attraction between the two masses which we call *gravitational force*. Thus, the gravitational force between the sun and a planet acts as centripetal force (always directed towards the sun) to keep the planet in its circular path. (You can feel the gravitational force of the earth causing the *weight* of a body on the earth. Due to this gravitational pull of the earth, e.g. a stone falls down to the earth where released.)

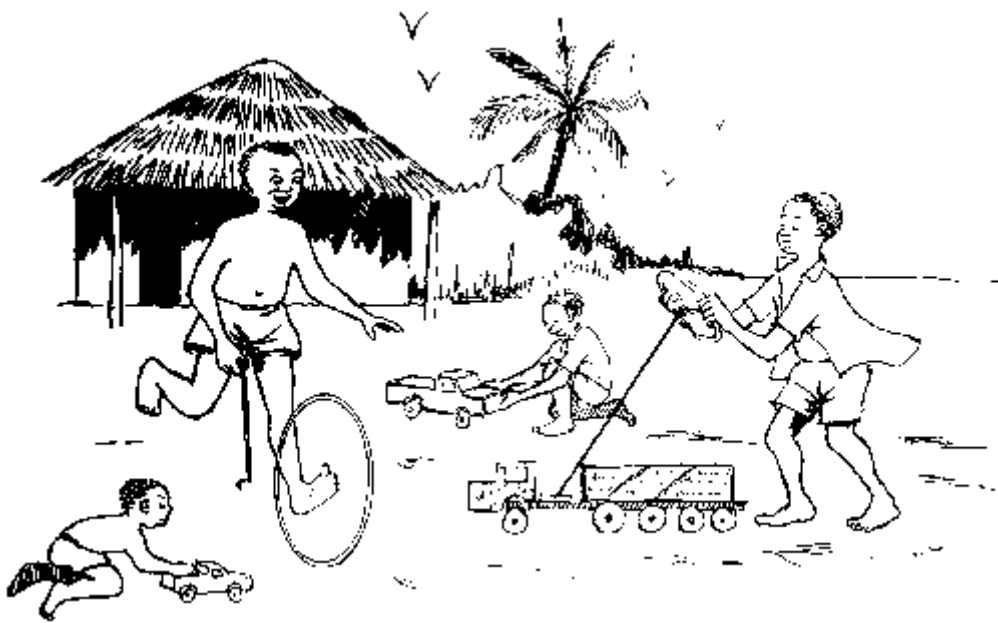
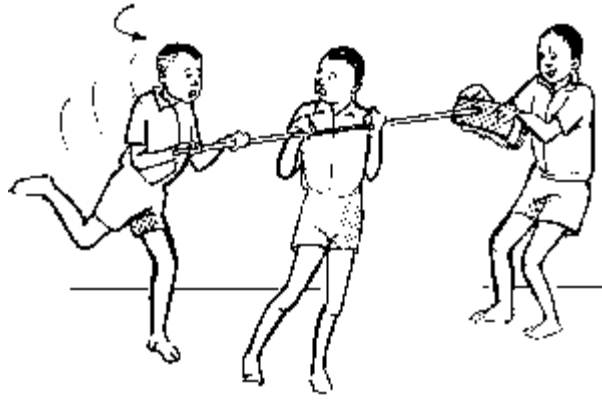

## 4. Matter

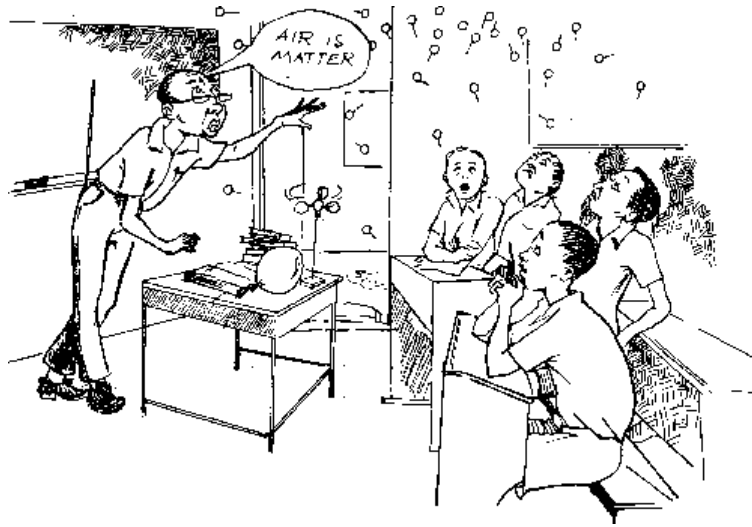

### 4.1 The Particle Model of Matter

*Matter* is anything which occupies space and has mass. It consists of very *small* particles called atoms or molecules which take part in chemical reactions. The particles possess kinetic energy. Therefore they are in constant vibration. The energy content increases with the increase in temperature. Hence, the motion of the particles increases with the temperature. Forces exist which hold the particles strongly together in *solids*, while they can easily move past each other in *liquids* and *gases*.

#### 4.1.1 Salt is Made of Particles

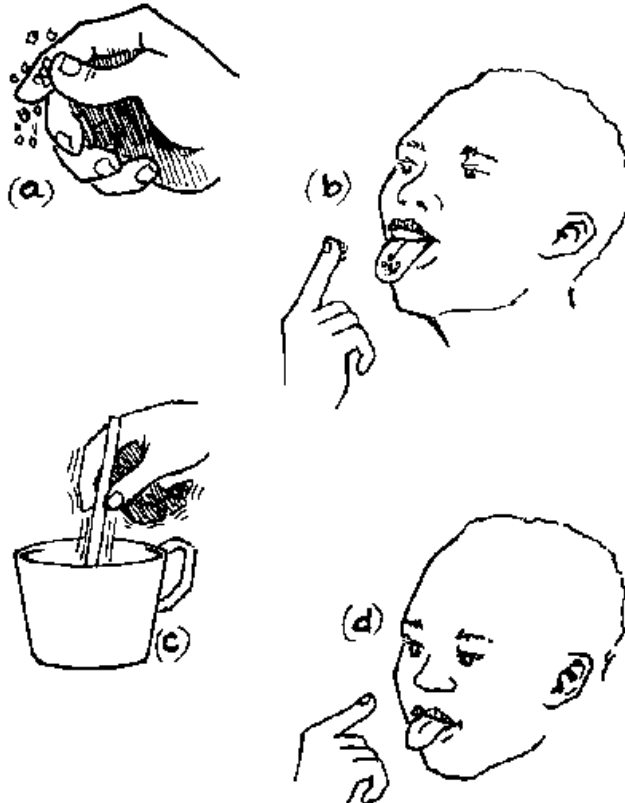

**P:** Take some salt (or sugar) crystals and roll them between your fingers in order to feel their hardness. Taste the crystals.

Take a small amount of boiled water and taste it.

Put salt (or sugar) crystals into the water and shake. What happens? Taste again.

**Q:** Describe and explain your observations.

**O:** Salt crystals are often of cubical shape. They are quite hard.

The crystals dissolve in water. The solution tastes like salt (or sugar).

**E:** Sugar or salt in water exists as very tiny invisible particles that can be identified by tasting.

#### 4.1.2 Water is Made up of Particles

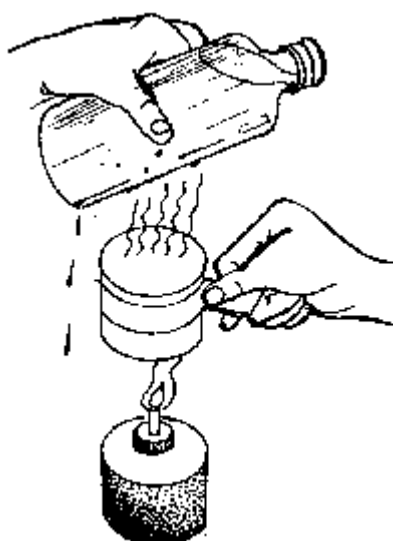

**P:** Pour a small amount of water into a tin can and heat it until it boils. Fill a bottle with cool water and hold it above the tin can.

**Q:** What do you observe?

**O:** Water drops form on the outside of the cool bottle wherever it is touched by the steam of the boiling water.

**E:** Water particles escape from the boiling water as vapour and condense on the lower surface of the bottle to form water droplets.

The formation of drops from vapour is an indirect evidence that water is made up of small particles.

### 4.1.3 Size of Particles

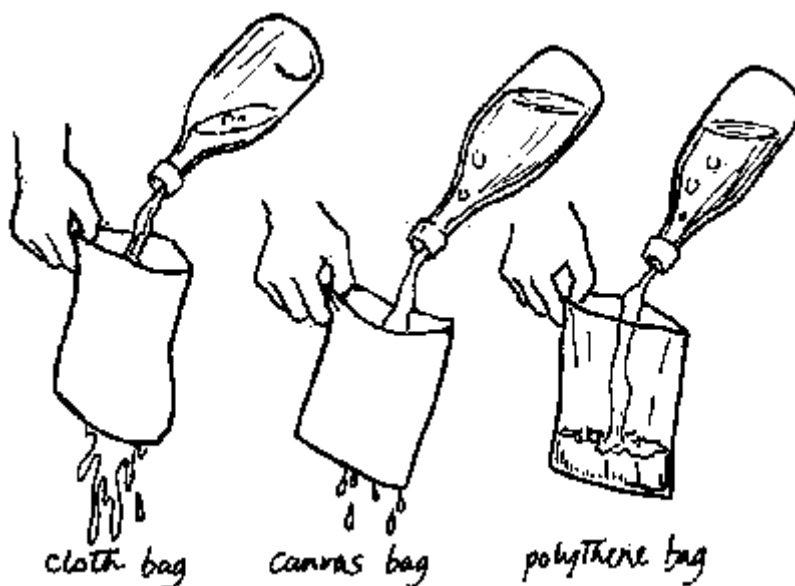

**P:** Make bags from cotton cloth, canvas cloth and polythene sheet. Fill water into the bags.

**Q:** What do you observe?

**E:** Water passes through cotton and canvas but not through polythene. This is because polythene has too small pores to allow water particles to pass through.

### 4.1.4 Feeling Particles



**P:** A wind is blowing vigorously towards a student carrying an open umbrella.

**Q:** What will she feel?

**E:** The umbrella is forced down by the wind pressure. This is due to the current of air particles (wind).



#### 4.1.5 Smelling Particles

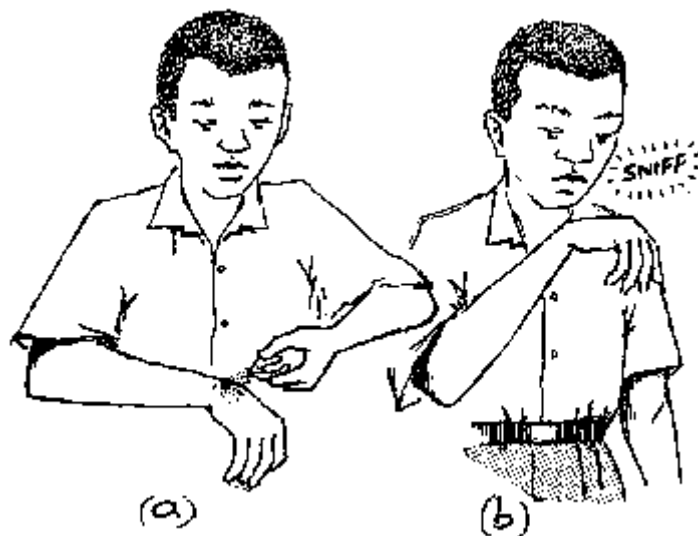

**P:** Let a student squeeze an orange peel.

**Q:** What can he sense?

**E:** He smells the orange, because invisibly tiny particles from the orange peel spread by diffusion to his nose.

#### 4.1.6 Weighing Particles

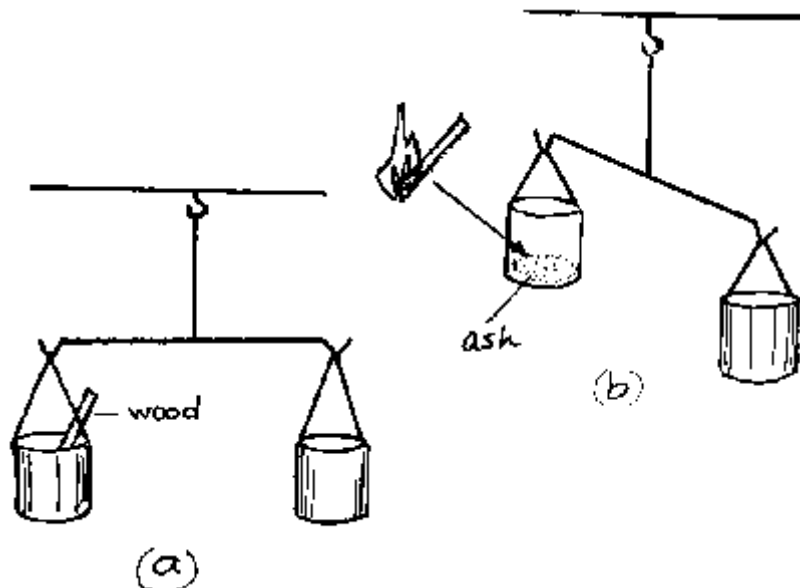

**P:** Ask students to weigh pieces of wood. Record the weight. Burn the pieces of wood and weigh the ash.

**Q:** Is there any difference between the weight of the wood and the ash?

**E:** The weight of ash is less than that of wood. The loss in weight is due to particles which escaped as soot and gas.

## 4.2 States of Matter

Matter exists in three states namely: solid, liquid and gas. The three states can be converted into one another by heating and cooling. In *solids* the particles are very close together and have a definite order. In *liquids* the particles are slightly farther apart than in solids and can move past each other. In *gases* the particles are in fast random motion. The three states differ mainly in the thermal energy each contains and as a consequence in the volume which equal masses of the same substance occupy.

### 4.2.1 Changes of State

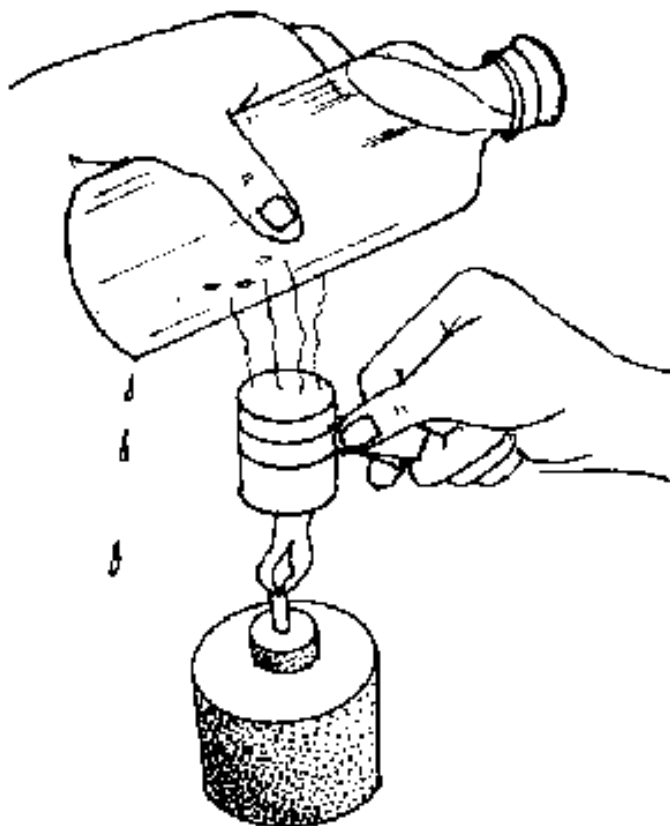

**P:** Heat pieces of candle wax carefully in a spoon or in a tin and hold a glass filled with cold water above it.

**Q:** What do you observe?

**O:** On heating, the solid melts to form a liquid and then by further heating the liquid evaporates as a vapour which is in gaseous state. The gas then condenses at the cold surface. This is similar to experiments performed with water (see 4.1.2, 5.3.1 and 5.3.2).

#### 4.2.2 Explaining the States of Matter

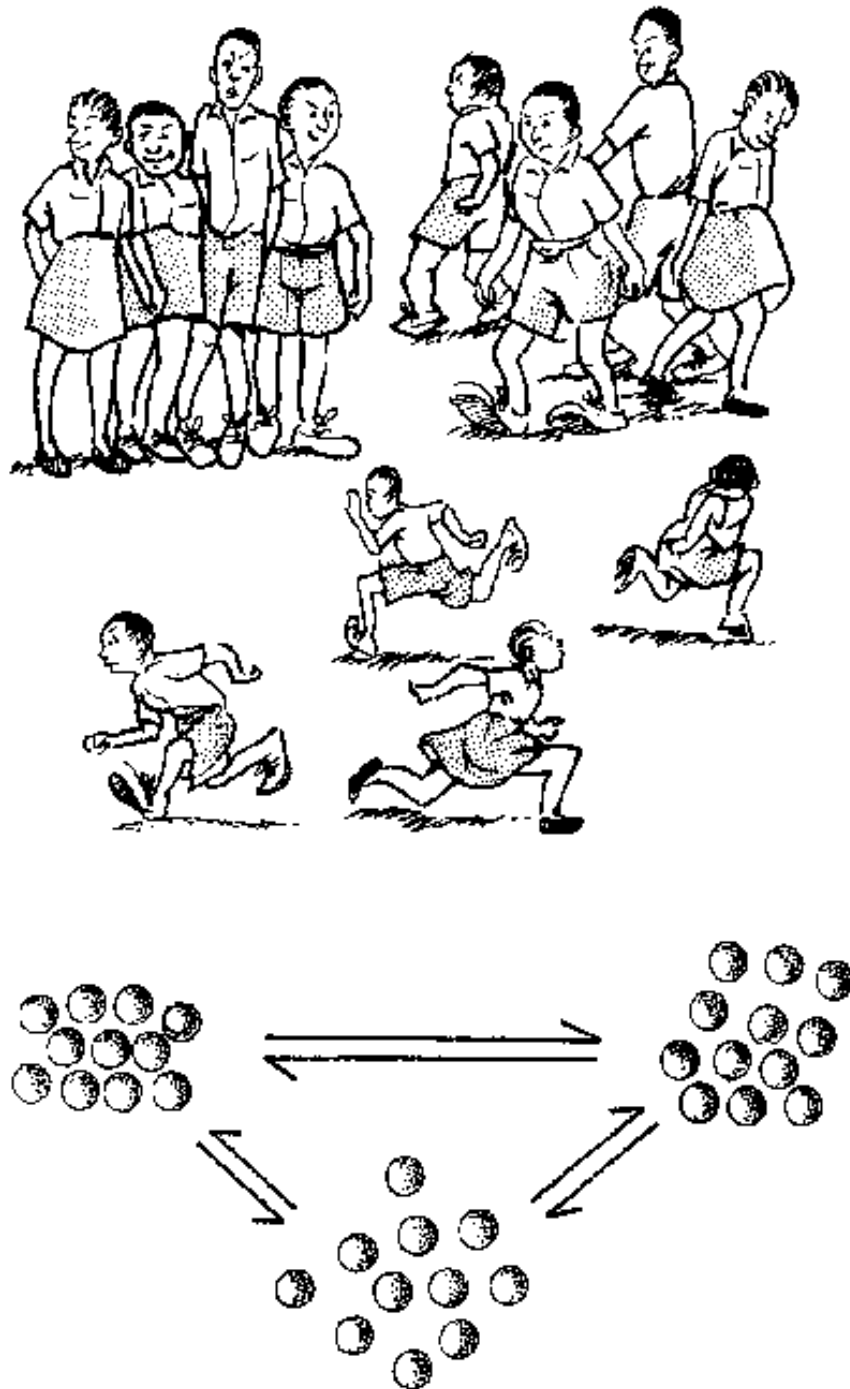

**P:** The three states of matter can be explained by simple models as shown in the figures above.

**Q:** What do the pictures represent?

**E:** Very close pupils or balls represent the particles in the *solid* state. Farther apart pupils or balls represent the particles in the *liquid* state. They move past each other. Fast and randomly moving pupils or balls represent the particles in the *gaseous* state.

### 4.3 Motion of Particles

Particles are in random motion. However, they cannot be seen. How do we get to know about their motion? The existence of the molecular motion can be deduced by indirect evidence through observation of *diffusion*. The movement of one kind of substance through a volume already occupied by another substance is known as diffusion. More direct evidence for molecular movement in gases or liquids comes from *Brownian movement*. Small visible particles can be seen in an irregular movement. From this we conclude that rapidly moving invisible gas molecules collide with them.

#### 4.3.1 Diffusion in Liquids

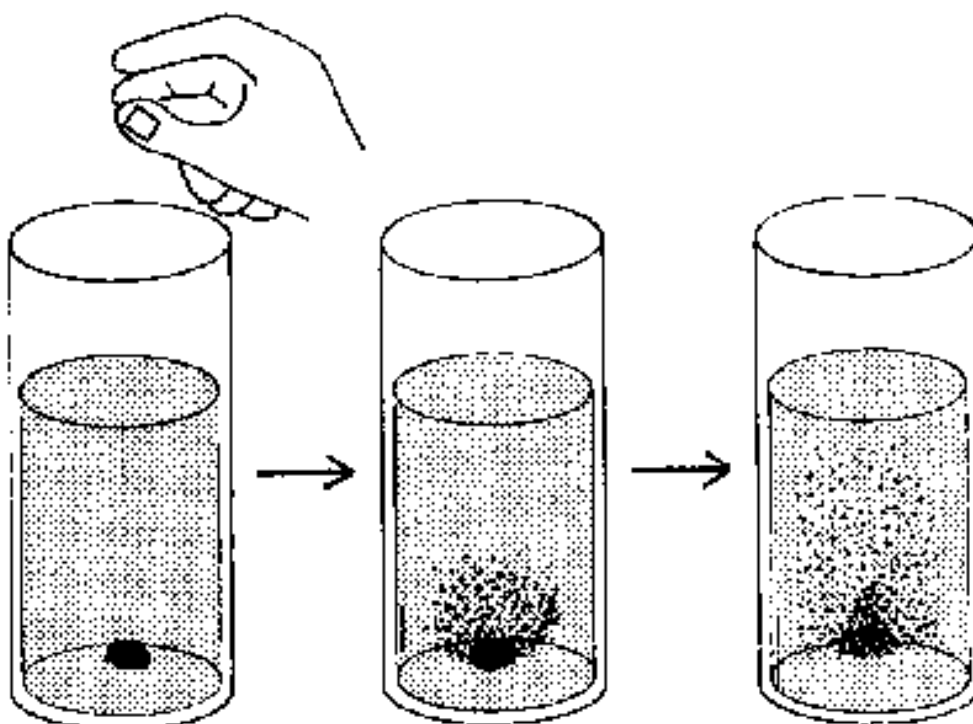

**P:** Put a crystal of potassium manganate (VII) (permanganate) into a jar containing water. Set the jar and observe.

**Q:** What do you observe?

**O:** The purple colour of potassium manganate(VII) (permanganate) will be found to spread gradually throughout the water.

**E:** This spreading out is due to the motion of the particles of potassium manganate(VII).

This process is called *diffusion*.

**H:** This is a slow process. Therefore allow the jar to stand for some days.

### 4.3.2 A Model on Motion

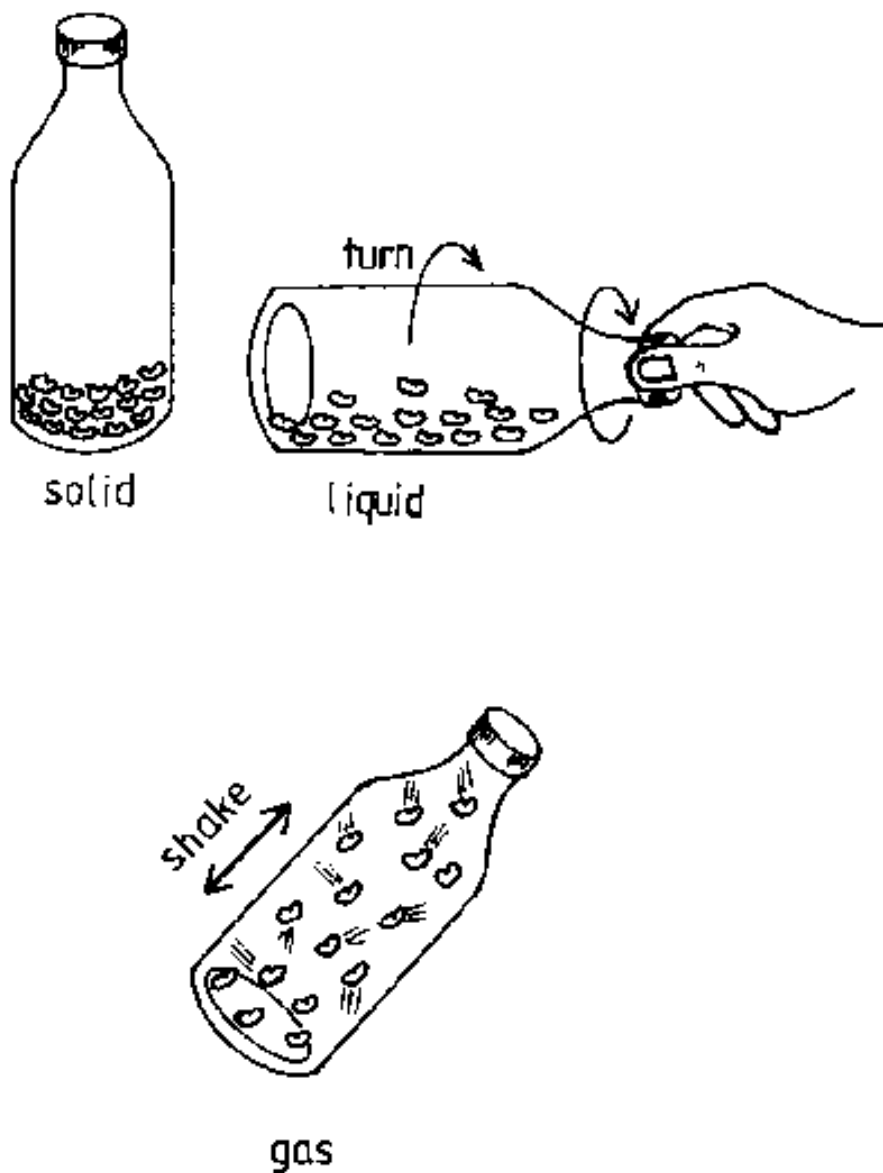

**P:** Put some dry beans, rice or stones in a transparent bottle. Hold the bottle still (a), then turn it (b). Then shake it vigorously (c).

**Q:** Which activity corresponds to which state of matter?

**E:** The movement of particles in *solids* is small and hence the particles are in a fixed order. In *liquids* the particles move past each other and have lost the stiff order. In *gases* the particles move very fast and randomly. They have now no order at all anymore. Hence, the observations in (a), (b) and (c) represent solid, liquid and gaseous state respectively.

### 4.3.3 Diffusion in Daily Life

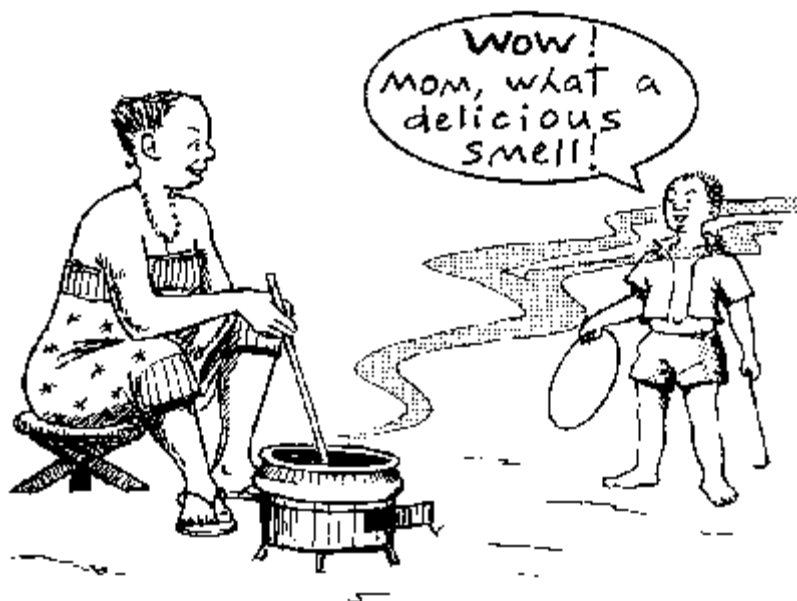

**P:** Pass near a place where people are roasting meat or cooking.

**Q:** What do you smell? Why?

**E:** The smell is sensed even at a distance, because the particles which produce the smell spread by *diffusion*.

### 4.3.4 Diffusion and Pollution



**P:** Pass near a polluted area (e.g. latrine, burning heaps of litter, a filling station).

**Q:** What do you smell?

**E:** Many hazardous substances spread to the environment by *diffusion*. (Hazardous substances in any state of matter in our environment mean *pollution*.)

#### 4.3.5 Brownian Motion



**P:** Observe a beam of light through dust in a dark room.

**Q:** What do you observe? Why?

**E:** The dust particles can be seen moving randomly. This demonstrates *Brownian motion*. What is seen is the consequence of the bombardment of the dust particles by invisible air particles. This is an indirect evidence for the existence of particles in the air.

#### 4.3.6 Model on Brownian Movement



Imagine there would be standing a tall adult person around whom small children are in a continuous random movement. The tall person would be punched permanently by the children and hence would be jerkily moved.

#### 4.4 Cohesion and Adhesion

There are two types of *forces between particles*. Forces between particles of the same material are called *cohesive forces* while those between particles of different materials are called *adhesive forces*. Cohesive forces hold the molecules in a water drop together. Nevertheless they are weak, so that the molecules can be easily separated, for example,

when we jump into water or when it is heated. Paints and all kinds of glues are based on the effects of adhesive forces.

#### 4.4.1 Exploring Cohesion and Adhesion

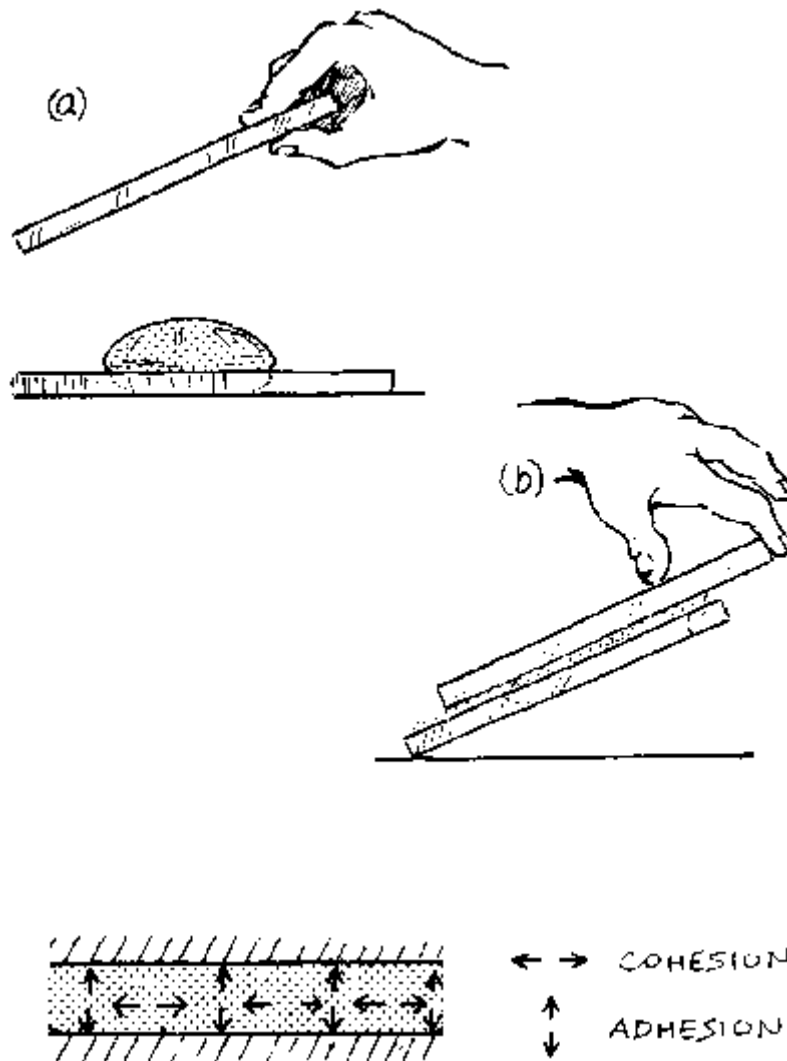

**P:** Drip water on a clean glass sheet (a).

**Q:** What happens?

**P:** Place a second glass sheet on the wet first sheet and try to lift it, see fig.(b).

**Q:** What do you notice?

**E:** (a) Water spreads to form a patch on the first glass surface because *adhesive forces* attract water molecules to the glass surface.

(b) A strong force is applied to separate the two glass sheets because the adhesive forces between glass and water are large.



#### 4.4.2 Water Drops from the Tap

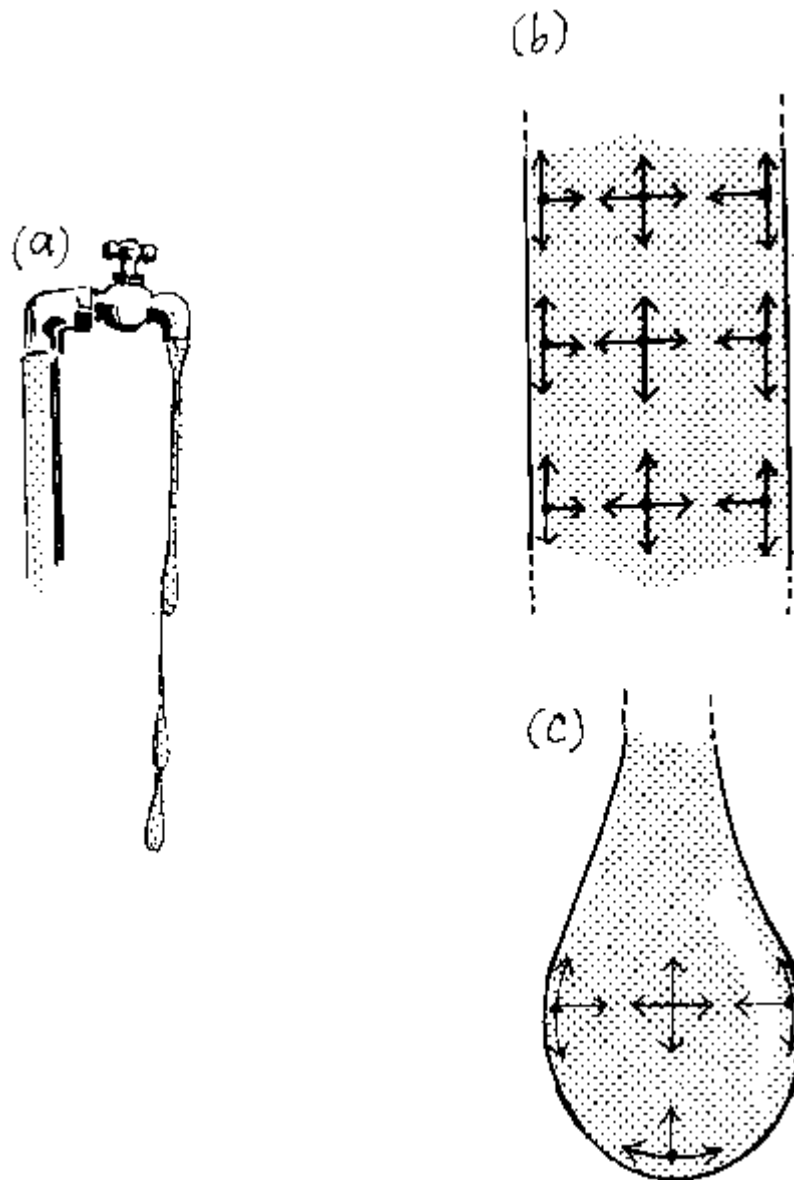

**P:** Let a thin stream of water flow from a water tap.

**Q:** What happens?

**O:** The water stream grows thinner and thinner as it moves further down and finally breaks to form drops.

**E:** Considerably strong *cohesive forces* exist as the stream starts to flow, but as the stream grows thinner the cohesive forces are overcome by the accelerating force of gravity and hence the stream is breaking down to drops. The molecules of the resulting drops are still held together by cohesive forces.

#### 4.4.3 Surface Forces

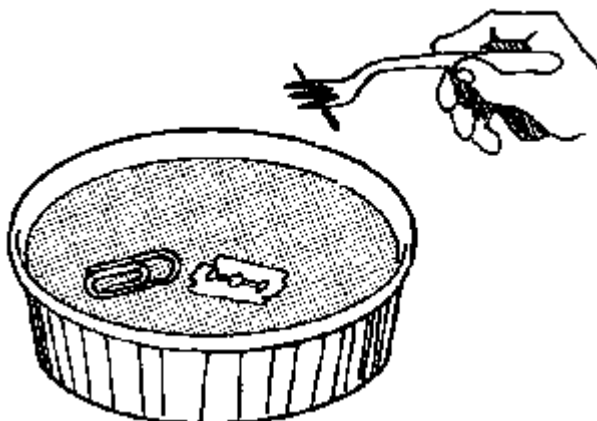

**P:** Carefully float a needle, a razor blade, a clip and a pin on a water surface as shown.

**P:** What do you observe?

**E:** The surface of water behaves like a thin elastic membrane. This is due to forces of cohesion called *surface tension*.

**H:** The pin can be easily floated with the help of a fork.

#### 4.4.4 More on Surface Forces

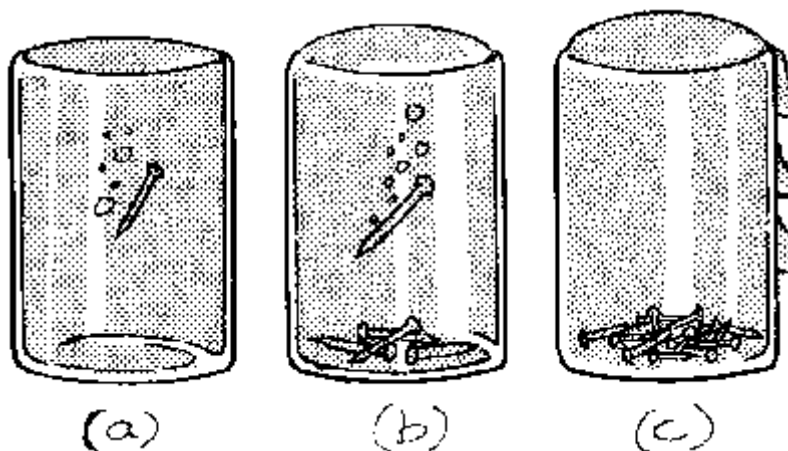

**P:** Carefully fill a transparent glass vessel with water to the rim. Add nails, one at a time, to the water and count the number of nails sunk just as water begins to spill over.

**Q:** Explain your observations.

**E:** The water surface bulges out but does not break immediately because of strong *cohesion forces* between the water particles.

#### 4.4.5 Affecting Surface Tension

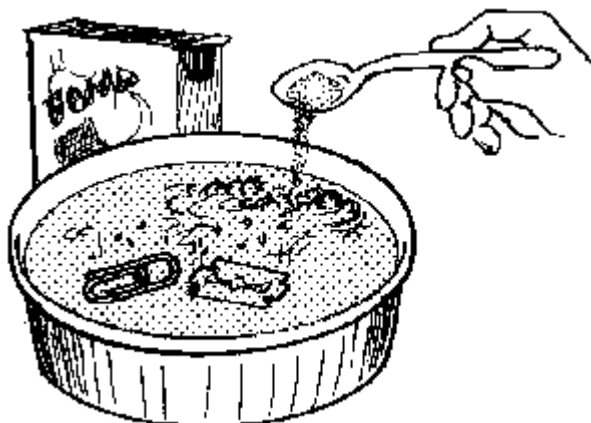

**P:** Repeat experiment 4.4.3 using detergent or soap solution instead of water.

**Q:** What do you observe?

**E:** Soap lowers the *surface tension* of water and therefore the bodies sink.

#### 4.4.6 Capillary Rise

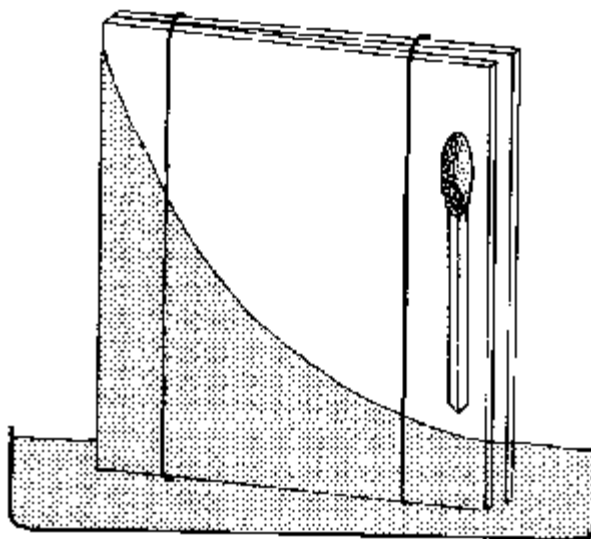

**P:** With the help of a rubber band and a matchstick, arrange two clean glass sheets as shown in the diagram. Place the arrangement in a plate containing some water.

**Q:** What do you observe?

**E:** Water rises to different heights along and between the glass sheets. This is *capillary action*. Water rises more where the glass sheets are closer together (see also 4.4.7).

#### 4.4.7 Measuring Capillary Rise

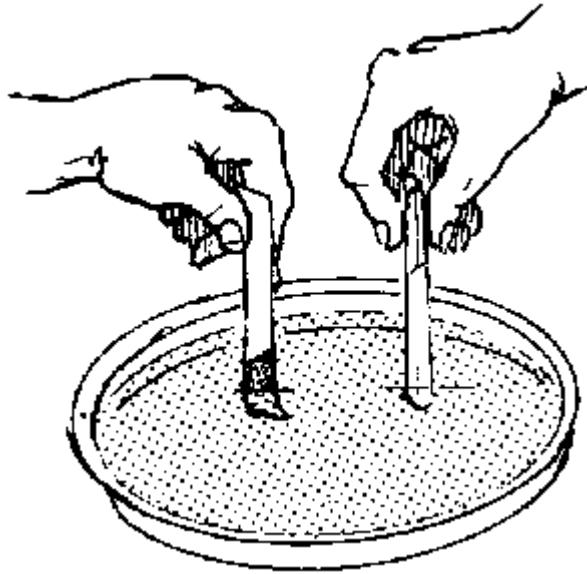

**P:** Hang a strip of newspaper and place a chalk-stick in a vessel containing water. Leave the arrangement for some time and measure the capillary rise in each with a ruler.

**Q:** Explain the causes of the differences in capillary rise.

**E:** Due to smaller capillaries water rises faster in the chalk-stick than in the paper.

**H:** Test other substances too.

#### 4.4.8 Automatic Irrigation

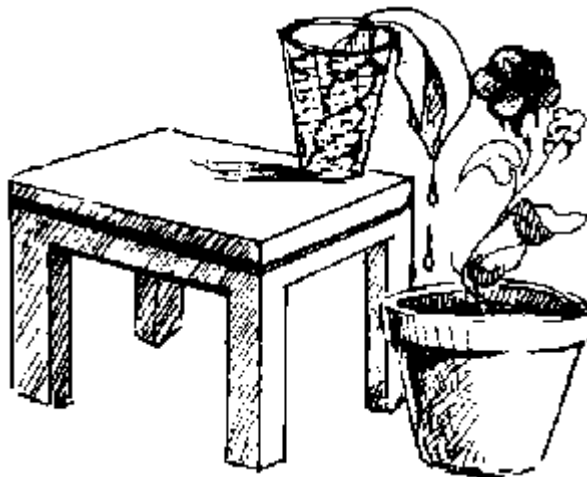

**P:** The knowledge of capillarity can be used to provide an automatic irrigation. Students can perform irrigation by dipping a porous material such as paper or cotton cloth in water.

#### 4.4.9 Inclined Water Transport

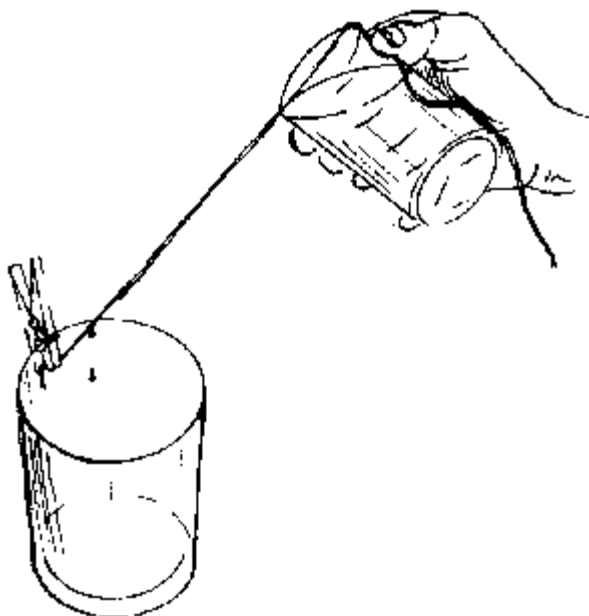

**E:** When *adhesive forces* are greater than *cohesive forces*, drops of water can be made to move down along an inclined thread.

#### 4.4.10 Weak Adhesion

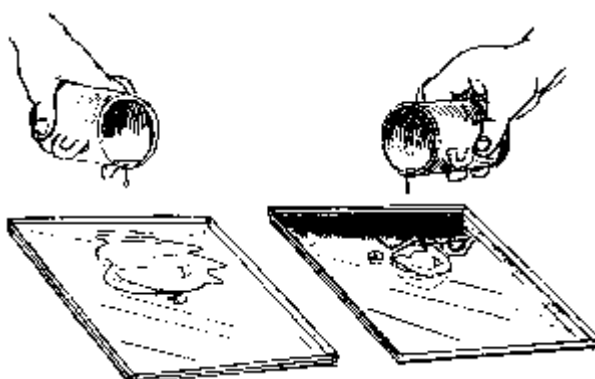

**P:** Put a few drops of water on a clear glass surface (a) and on a sooty or greasy surface (b).

**Q:** What do you observe?

**E:** The shiny surface gets wet because the *adhesive forces* between water and glass are very great. The sooty or greasy surface does not get wet because adhesive forces between water and these surfaces are very weak.

#### 4.5 Elasticity and Viscosity

*Elasticity* is the ability of a substance to recover its original shape after a distorting force is removed. *Hooke's law* on elasticity states that the extension of a spring is directly proportional to the load applied provided the elastic limit is not exceeded. Most materials are elastic. It is important to know the behaviour of a material when acted by forces before we can use it for a particular job.

*Viscosity* is the frictional force exerted by a fluid. The flow of liquids is influenced by this force. Where the frictional force is greater, the liquid flows less readily and is said to be more viscous and vice versa.

#### 4.5.1 Elasticity in Solids

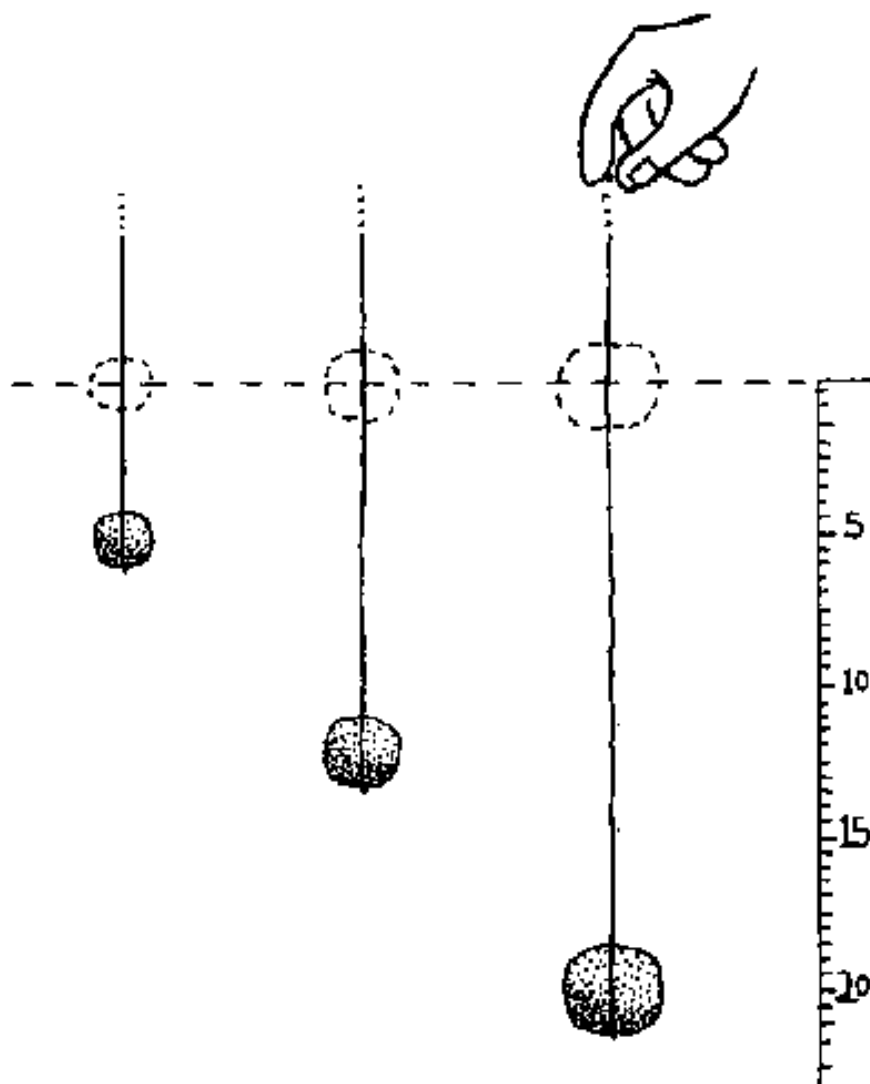

**P:** Attach various masses (e.g. 1 g, 2 g, 3 g) to a rubber band or a spring and measure the extension for each mass attached. Remove the masses in succession and record the corresponding readings.

**Q:** What happens when the masses are removed one after the other?

Plot a graph of extension (y-axis) against mass (x-axis).

**E:** The graph obtained shows that the extension is proportional to the mass which is *Hooke's Law*.

#### 4.5.2 Viscosity in Liquids

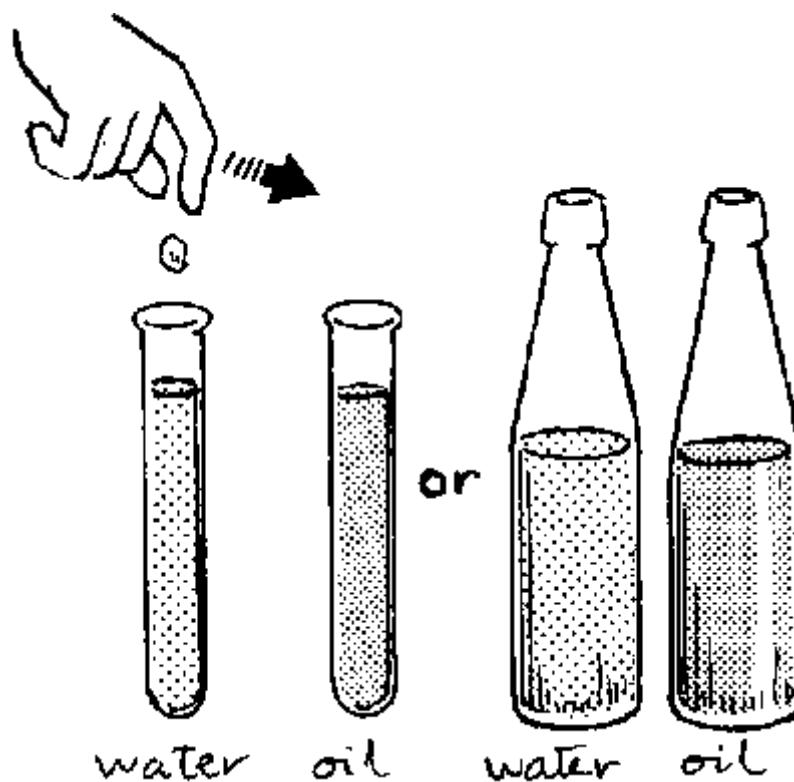

**P:** Fill one test-tube or a tall bottle with water and another with oil, both to the rim. Put a small stone into the water and record the time taken by the stone to reach the bottom. Repeat the experiment using oil.

**Q:** In which liquid does the stone take longer to reach the bottom?

**E:** The stone takes longer to reach the bottom in the vessel containing oil because oil has a higher *viscosity* than water.

## 5. Thermal Physics

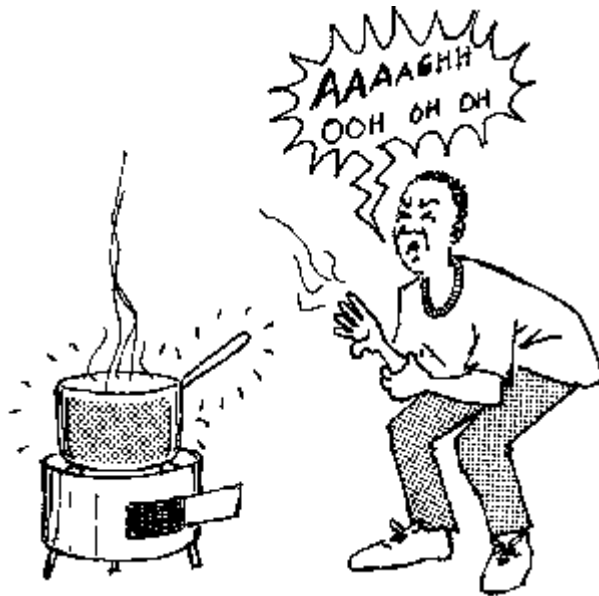

### 5.1 Thermal Energy and Temperature

Thermal energy is a form of energy which can easily be produced by converting other forms of energy. Thermal energy is commonly called *heat*. The quantity of heat absorbed by a body generally causes an increase in its temperature. The *upper fixed point* of a thermometer is the temperature of the steam of pure water boiling at standard atmospheric pressure. It is  $100^{\circ}\text{C}$ . The *lower fixed point* is the temperature of pure melting ice at standard atmospheric pressure. It is  $0^{\circ}\text{C}$ . *Absolute zero* is the coldest possible temperature which is  $-273^{\circ}\text{C}$ . This corresponds to the zero degree on the kelvin scale.

#### 5.1.1 Sources of Thermal Energy

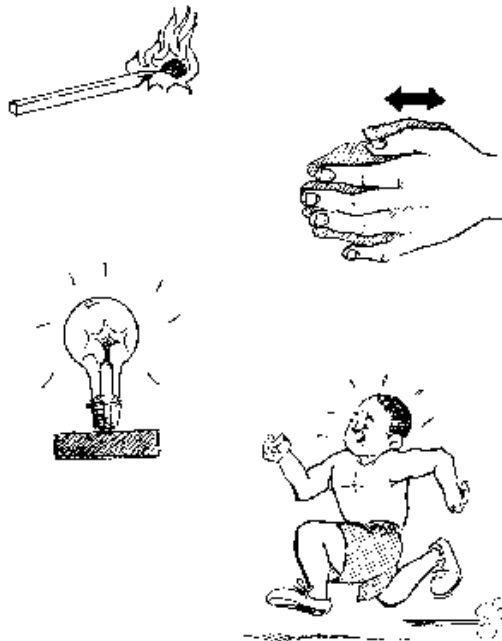



**P:** Ignite a match stick. Rub your hands very vigorously. Switch on an electric bulb. Run as fast as you can a certain distance or up a staircase.

**Q:** Which forms of energy are converted to thermal energy in each case?

**E:** (a) A match stick burns converting *chemical energy* into *thermal energy*.

(b) An electric bulb gets heated because *electric energy* is converted to *thermal energy*.

(c) The hands get hot, because *mechanical energy* is converted to thermal energy.

(d) We feel hot, because our body converts the *chemical energy* of the food partially to *thermal energy*.

### 5.1.2 Principle of a Thermometer

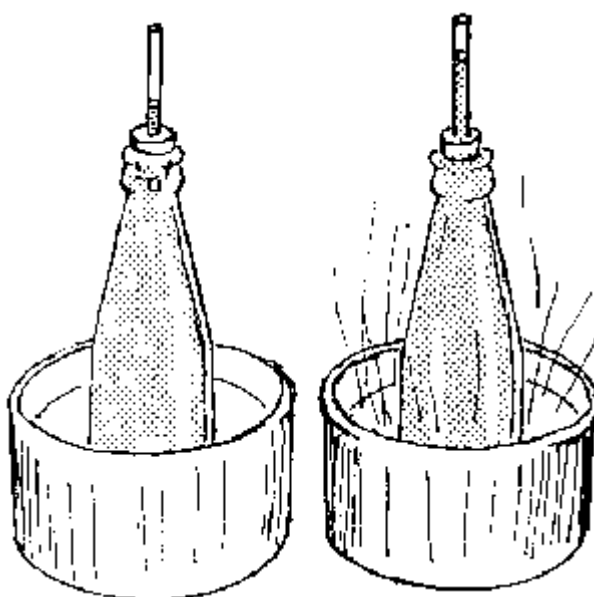

**P:** Fill a small bottle (about 0.5 litre) with coloured water up to the rim. Tightly fix a stopper which is carrying a narrow transparent tube (e.g. an empty ball pen tube) into the mouth of the bottle. The liquid level should be just visible above the stopper. Then put the bottle into hot water or heat it gently.

**Q:** What happens to the liquid level in the tube? Why?

**E:** The liquid level rises, because the liquid is expanding on being heated.

**A:** The principle of expansion of liquid is used in clinical thermometers. In the clinical thermometer the expansion of mercury is used to measure the body temperature. Obtain a clinical thermometer and discuss its scale. Ask the students to draw a diagram of the thermometer. Some out-door thermometers contain coloured alcohol instead of mercury. The expansion of alcohol is six times greater than that of mercury. Mercury is often used in thermometers for measuring higher temperatures than alcohol because it has a higher boiling point than alcohol.

### 5.1.3 Fixed Points

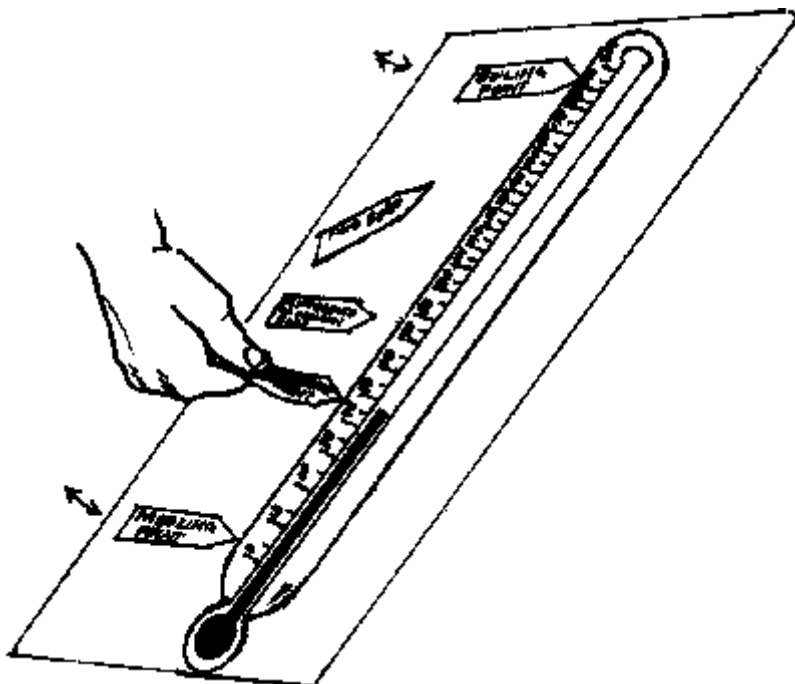

**P:** Draw a large diagram (a display chart) of a thermometer on a paper (paper from cement bags is suitable). Cut out paper arrows for indicating the characteristic fixed points for water and other substances. The pupils can be asked to indicate (using the arrows) the appropriate fixed points on the diagram.

### 5.1.4 Specific Heat Capacity of Liquids

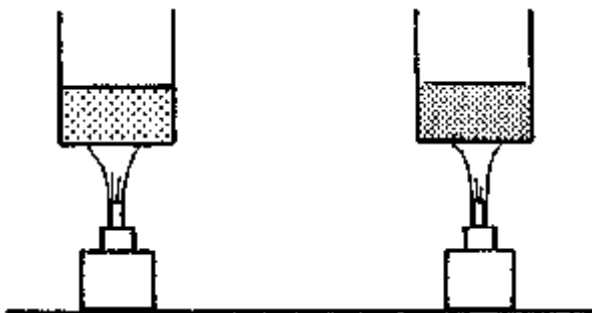

**P:** Heat equal masses of different liquids (e.g. water and oil) in two identical containers using a "kibatari" (kerosine lamp) for the same length of time.

**Q:** What difference in temperature can you feel with your finger?

**E:** The temperature of the oil is higher, because it needs less energy to raise the temperature of one gram of oil by  $1^{\circ}\text{C}$  than that of water. Thus, using the same amount of heat and mass, the temperature of oil must be higher.

**H:** Great care must be taken when heating oil, for it can catch fire (and you should not put your finger in it, if you have heated it for a long time).

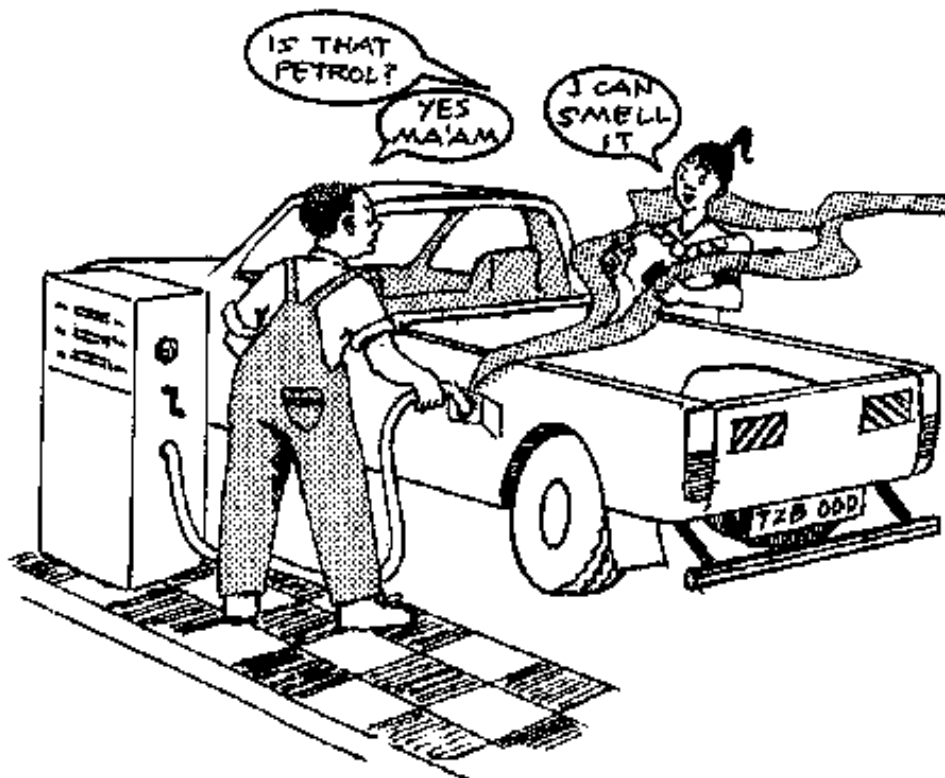

### 5.1.5 Thermal Energy

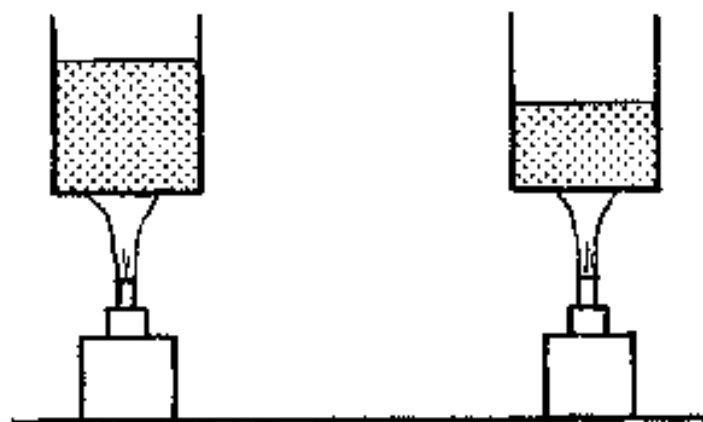

**P:** Heat different quantities of water using a "kibatari" (kerosine lamp) in two identical containers (e.g. tin cans) for the same length of time. Dip your finger into the two containers of water.

**Q:** What differences in temperature can you feel?

**E:** The temperature of the smaller quantity of water is higher, because it received more thermal energy per gram of its mass than the larger quantity. So for the same heat input the temperature rise of the smaller quantity of water will be greater.

### 5.1.6 Application of Specific Heat Capacity



**P:** Using your hand find out how fast a water puddle and a heap of sand warm up during the day. Find out again how fast they cool during the night.

**E:** A heap of sand heats up faster during the daytime and cools down faster during night, because sand has a lower specific heat capacity than water. (Specific heat capacity of water =  $4200 \text{ J/kg}^\circ\text{C}$ ; of sand =  $800 \text{ J/kg}^\circ\text{C}$ ).



### 5.2 Thermal Expansion

Solids, liquids and gases expand when heated and contract when cooled. Expansion and contraction occur in all directions. The kinetic theory explanation is, that the particles vibrate with large amplitudes when heated, forcing each other a little further apart. Cooling reduces

the amplitude of vibration and brings the particles closer together. *Water* has an anomalous expansion. Its highest density is at 4°C. Therefore in cold regions water at this temperature always sinks to the bottom of lakes. This is why in cold regions the water at the bottom of the lakes does not freeze.

### 5.2.1 Expansion Apparatus

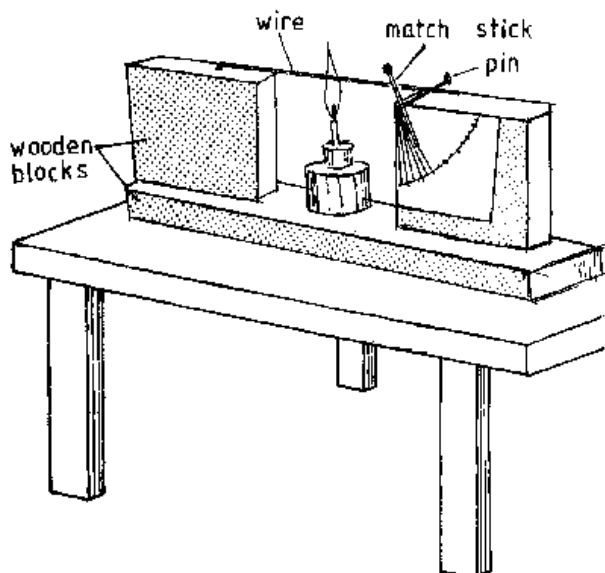

**P:** Place a metal rod horizontally with one end fixed firmly on a wooden block. Insert the pin through a match stick and place it under the rod as shown in the figure. Heat the rod from below with a candle or a "kibatari" (kerosine burner).

**Q:** What do you observe?

**E:** The match stick turns in the clockwise direction, because the rod expands causing the pin to roll forward and the match stick to turn. **H:** For the best results the pin should lie on a smooth surface. A wire of 2 mm diameter or a bicycle spoke can be used for the metal rod.

### 5.2.2 A Simple Model for Explaining Expansion

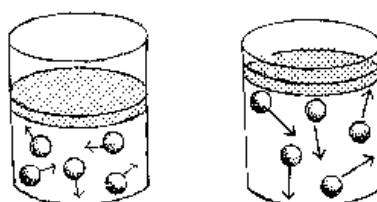

**P:** Expansion can be explained by a simple human model: When a group of pupils stands still, they are close together and they do not need much space. But if they start to dance or even to run about, each of them needs more space and the group as a whole takes more space. The particles in a body are like the pupils in the group, they only move far apart when they are heated and hence need more space.

### **5.2.3 Expansion of a Coin**

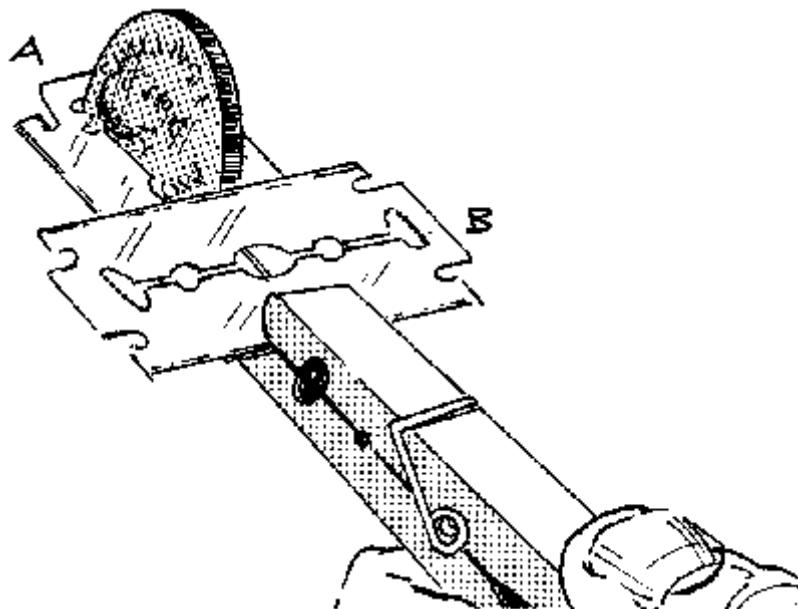

**P:** Place a coin into the slit of a razor blade A. Slide a second blade B so that the coin just passes through the slit. Firmly clamp the blades together with pegs or clips. Now remove the coin and heat it in a flame and try to pass it through the slit again.

**Q:** What happens?

**E:** The coin does not pass through, because it has expanded due to heating.

### **5.2.4 Expansion of a Wire**

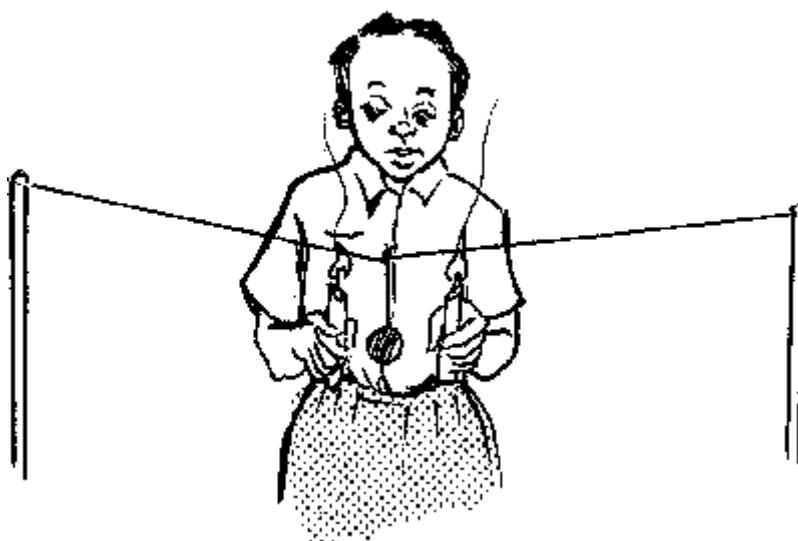

**P:** A thin copper wire is firmly fixed between two chairs and a weight is hung in the middle to stretch the wire. Then heat the wire along its length.

**Q:** What happens to the weight?

**E:** The weight sags further down, because the heated wire expands and hence increases in length.

### 5.2.5 Applied Expansion

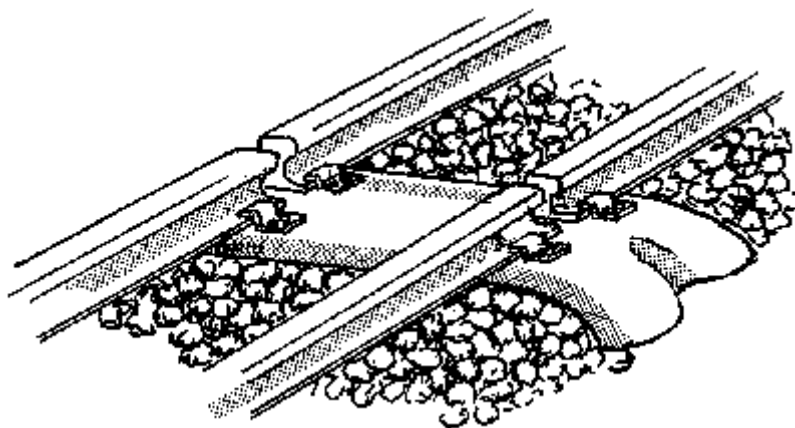

Steel railway lines have gaps at the end of each length of rail. Clicks can be heard as the wheels go over them.

**Q:** Why are the gaps necessary?

**E:** The gaps are needed to allow the rails to expand without bending during hot days. The gaps are called *expansion gaps*.

### 5.2.6 Bimetal Principle

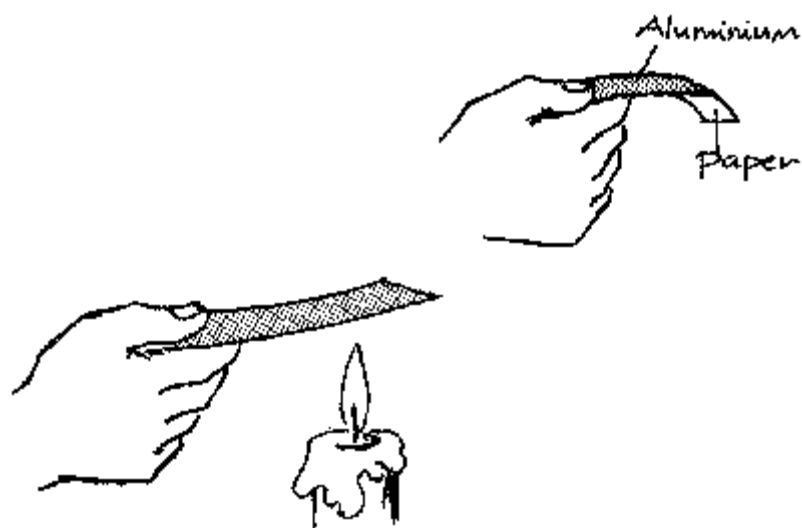

**P:** A bimetallic strip is made of two different metal strips like iron and brass or iron and aluminium joined together. To show the principle of a bimetallic strip, cut a one centimeter strip of aluminium paper from a cigarette packet and hold it close to a flame.

**Q:** What happens?

E: The strip bends towards the paper side, because aluminium expands more than paper.

### 5.2.7 Expansion of a Liquid

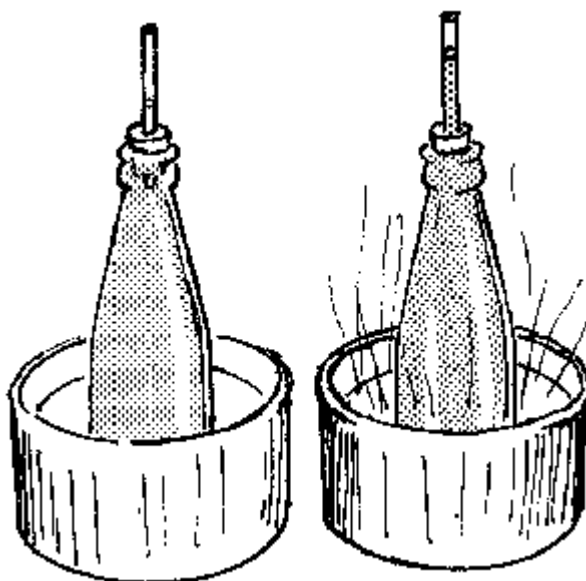

**P:** Fill a bottle up to the rim with coloured water. Tightly fix a cork bearing a transparent plastic tube (an empty ball point pen tube). Place the bottle into hot water.

**Q:** What happens?

**E:** The liquid rises along the tube, because it is heated by the hot water and expands along the tube.

### 5.2.8 Allowing for Liquid Expansion

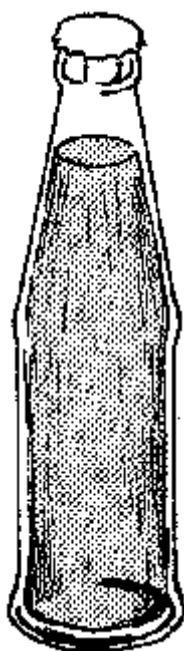



**P:** Observe the top of soda or beer in a corked bottle.

**Q:** Why does the bottle contain a small amount of gas trapped above the soda or beer?

**E:** The space is to allow the expansion of soda or beer when the bottle is stored in a warm place.

### **5.2.9 The Jumping Coin**



**P:** Wet the rim of a bottle with water and cover it with a coin (e.g. a shilling coin). Place the bottle into a hot water bath.

**Q:** What happens to the coin after a short time?

**E:** The coin vibrates opening and closing the bottle. This is because when the air inside the bottle expands, it pushes up the coin and when the air escapes, the pressure inside drops and the atmospheric pressure pushes down the coin.

### **5.2.10 Contraction of Air**

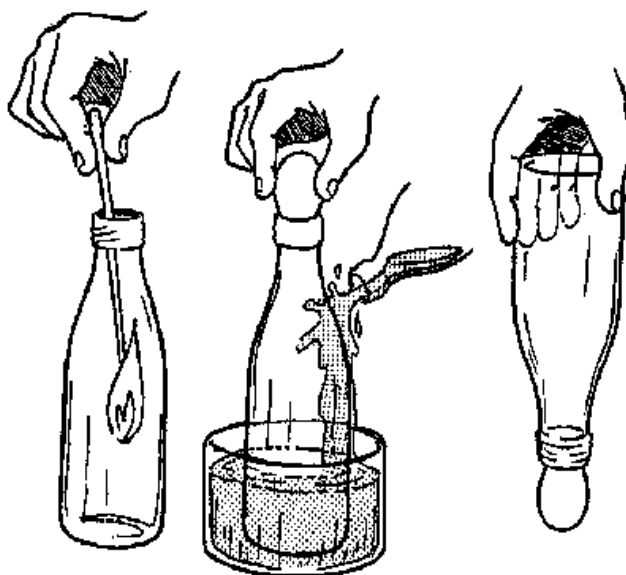

**P:** Place an "empty" bottle into a hot water bath or burn some paper or a wooden stick in it. After it has warmed up, close the bottle either with your thumb or a boiled and peeled egg. Now immerse the bottle in cold water.

**Q:** What do you observe?

**E:** The thumb or egg will be held by the bottle, because on cooling the bottle the air inside contracts and creates a lower air pressure inside.

### 5.3 Changes of State

There are three states of matter, *solid*, *liquid* and *gas*. Matter can be converted from one state to another:

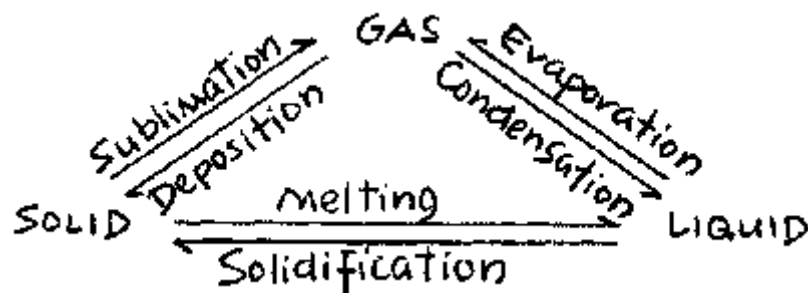

Every pure substance has *characteristic fixed points* at which one state changes into another one. That depends on the temperature. The water cycle in the atmosphere illustrates the change of state of water.

#### 5.3.1 Changes of State of Water

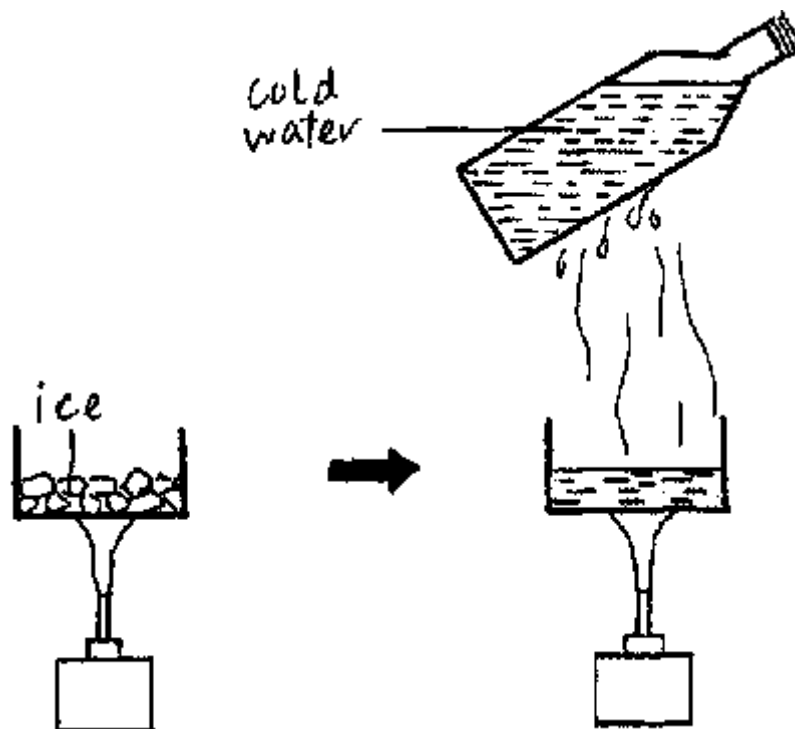

**P:** Heat ice in an open can for a few minutes and hold a glass bottle filled with cold water above the can.

**Q:** Which changes of state can you observe?

**E:** The ice changes from solid to liquid (*melting*) in the can. The liquid changes to gas (*boiling*) and the steam changes to liquid on the cold surface of the cold bottle (*condensation*).

### 5.3.2 Rain and Hailstone Formation

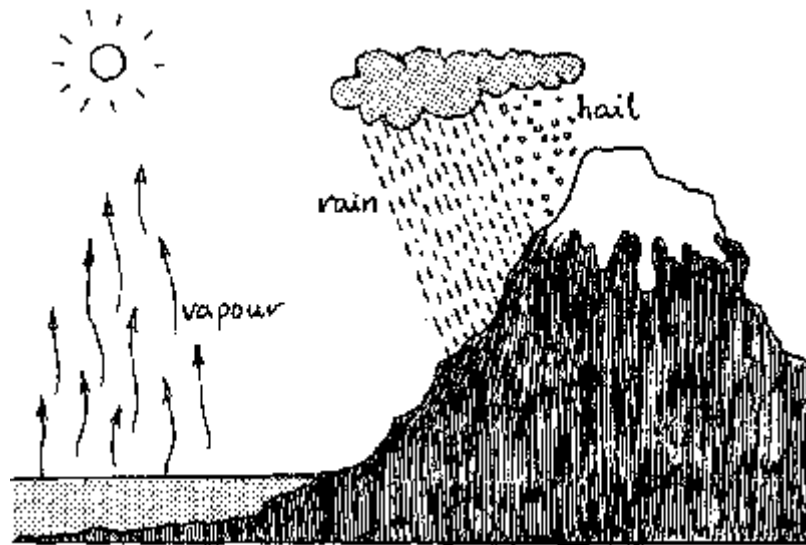

**P:** Rainfall is a common occurrence all over the country and sometimes the rain is accompanied by hailstones which destroy our crops.

**Q:** Can you explain how rain and hailstones are formed?

**E:** The sun heats the sea and lakes. The water evaporates and rises up in the air. The vapour cools and condenses into water droplets forming a part of the clouds. At higher altitudes where temperatures are very low, bigger drops of water are formed which fall as rain. At times bigger drops of water turn into ice (solid) and fall as hailstones.

### 5.3.3 Evaporation



**P:** Pour some spirit or petrol on the back of your hand.

**Q:** Explain what you feel as the spirit evaporates.

**E:** The back of the hand feels cold, because evaporation of the spirit needs energy which it absorbs from the skin.

### 5.3.4 Evaporation



**P:** A boy plunges himself into a pool of water and then gets out.

**Q:** Explain the change of the temperature of his body.

**E:** He feels very cold (chilly) because the evaporation of water from his body absorbs heat from his skin making him feel cold. This explains why we feel very cold when we stand in a draught of air after sweating.

### 5.3.5 Cooling Water

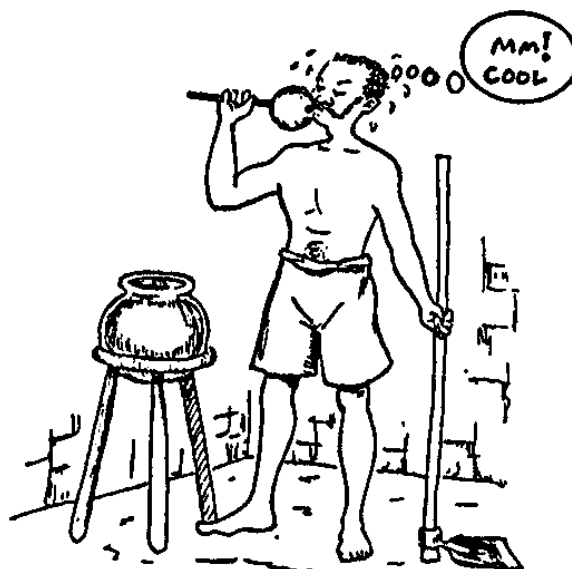

**P:** Touch the blackboard with a wet hand.

**Q:** Observe the trace for some minutes.

**P:** In many houses water is kept in fired clay pots (*chungu*). Water pots have very tiny pores through which minute amounts of water ooze out.

**Q:** Explain how water is cooled in these clay pots.

**E:** Some water passes through the tiny pores and evaporates. The energy needed for the evaporation is taken from the pot and water and hence the water cools down.

### 5.3.6 The Refrigerator

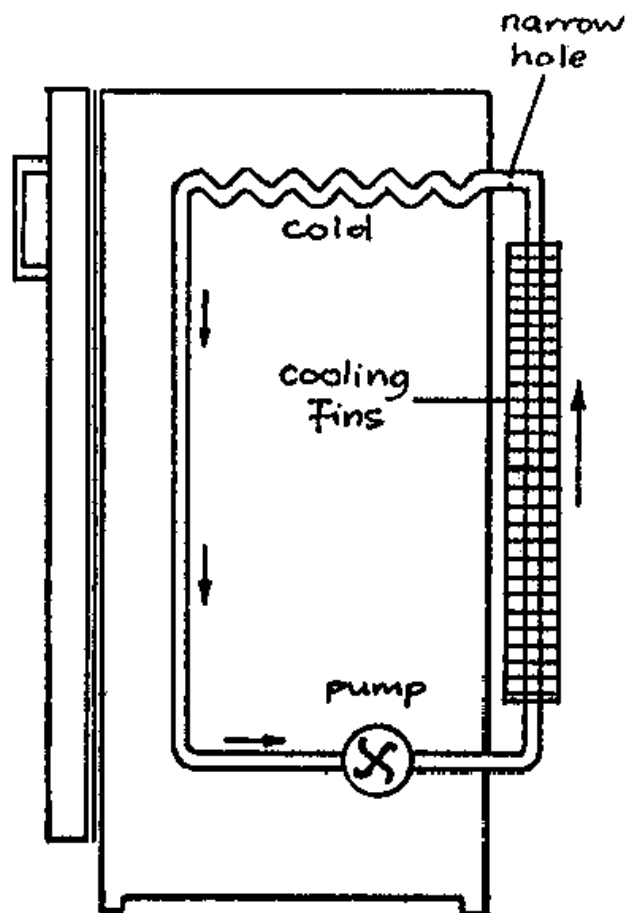

**E:** Some urban households have got refrigerators. In the refrigerator a special liquid is circulated through a pipe. In one portion of the pipe the liquid evaporates at a low pressure. The energy for the evaporation is taken from the pipe which cools the inner part of the refrigerator. In the pipe at the back the vapour condenses to a liquid under high pressure, thus giving out heat. Therefore cooling fins on the outside have to transmit this heat to the air.

### 5.3.7 Pressure and Melting Point

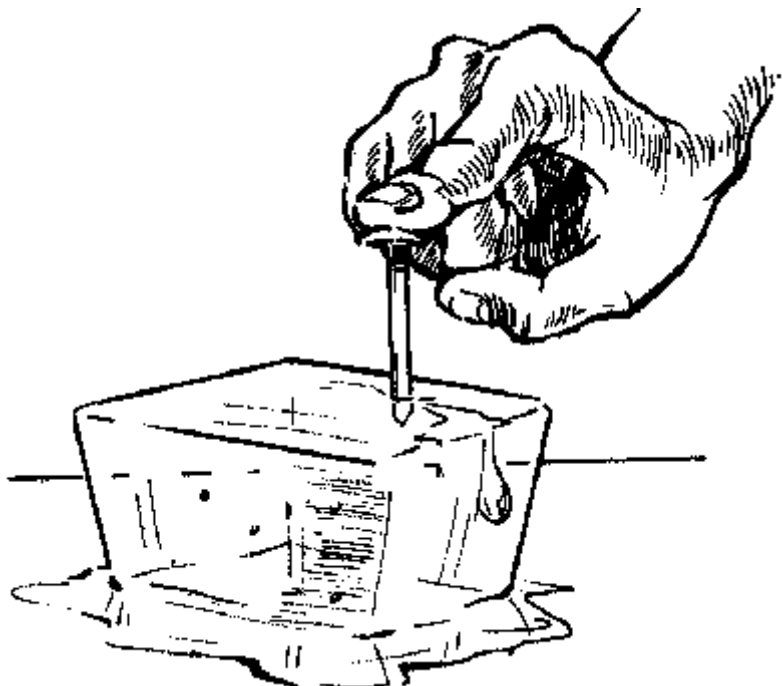

**P:** Steadily press a nail or a screw into a block of ice without heating it.

**Q:** What happens?

**E:** The nail penetrates into the ice because the pressure causes the ice at the tip of the nail to melt. (This is so, because water has less volume than the same mass of ice.) But when you release the pressure on the nail the water freezes again and "glues" the nail into the block of ice.

### 5.3.8 Impurities and Melting Point

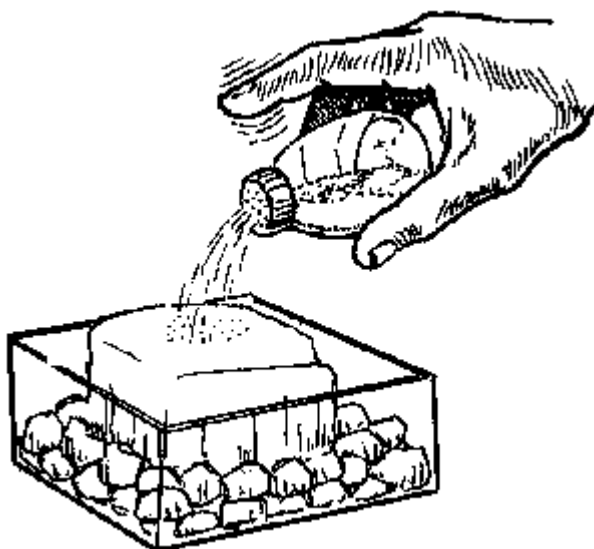

**P:** Place some pieces of ice in a glass container and sprinkle some salt on the ice. Stir the mixture and measure the temperature.

**Q:** What do you observe?

**E:** The ice pieces melt at a lower temperature than  $0^{\circ}\text{C}$ . *Impurities (e.g. salt) lower the melting point of ice.*

### 5.3.9 Pressure and Boiling Point



**P:** Some people who go for mountain climbing expeditions take pressure cookers with them for cooking on the peak of a mountain.

**Q:** Can you explain why?

**E:** The air pressure decreases with the altitude and water will boil at a lower temperature on the peak of a mountain. Generally, *the lower the pressure on the water, the lower its boiling point*. Thus, food would need a very long time to be cooked e.g. on the top of Mount Kilimanjaro. So for food to cook faster we need to use a pressure cooker so that the temperature inside increases to cook the food faster.

### 5.3.10 The Pressure Cooker

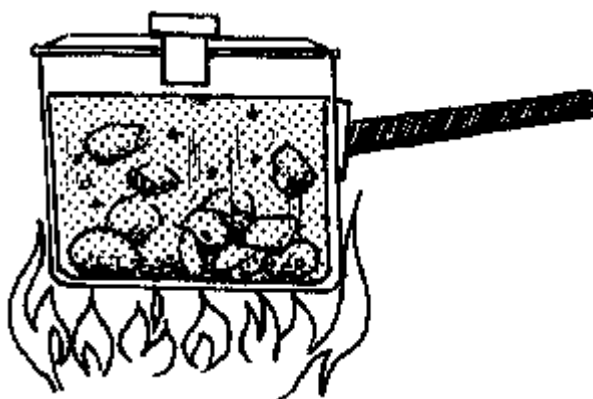

**P:** Demonstrate how a pressure cooker works.

**Q:** Explain how it helps to save energy costs.

E: Under the high pressure in such a pot the water boils at a higher temperature of about 120°C. At this temperature food like beans need only about one hour (instead of 3 hours in a normal pot) to cook and become soft. Therefore the pressure cooker uses less fuel to cook and hence saves fuel.

## 5.4 Transfer of Thermal Energy

Heat can be transferred in three ways:

*Conduction* of heat is the transfer of heat through a material from one point to another, whenever there is a temperature difference between the two points.

*Convection* of heat is the transfer of heat energy due to the movement of the material particles of the medium.

*Radiation* of heat is the transfer of heat energy from one place to another without the use of any material medium.

### 5.4.1 The Football Model Of Thermal Energy

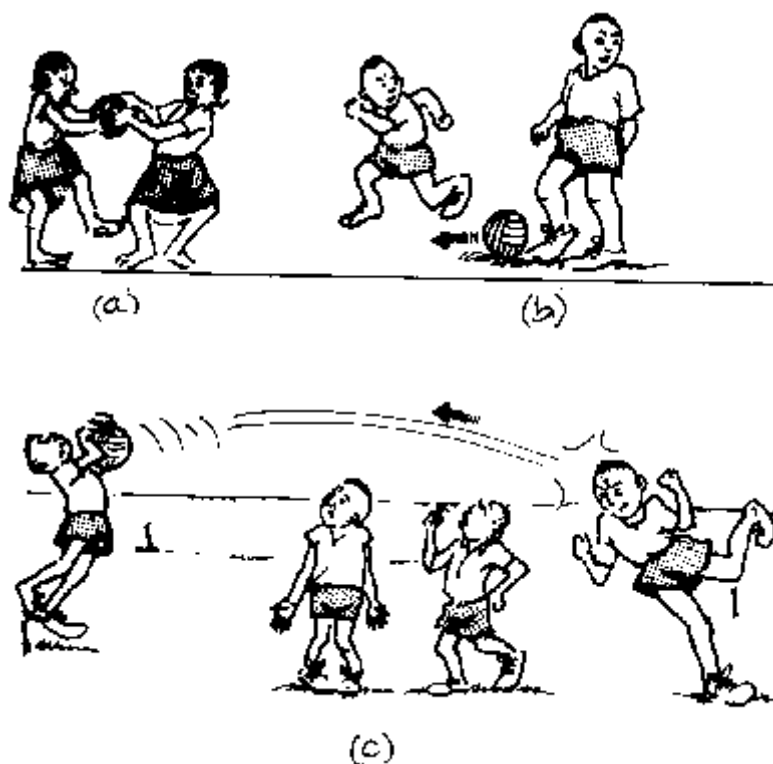

*Heat conduction* is likened to a football being passed from one player to another just as heat passes from one molecule to another in conduction of heat as shown in figure (a).

*Convection* is likened to a football being taken by one player from one point of the playground to another one just as heat in a gas or liquid is transported by a particle from one point to another in convection of heat as in figure (b).

*Radiation* is likened to a football being kicked by one player from one point at the playground to another one without the use of intervening players just as heat is transmitted from a hot object to another without any medium by radiation of heat as in figure (c).



## 5.4.2 Candle Flame and Heat Transfer

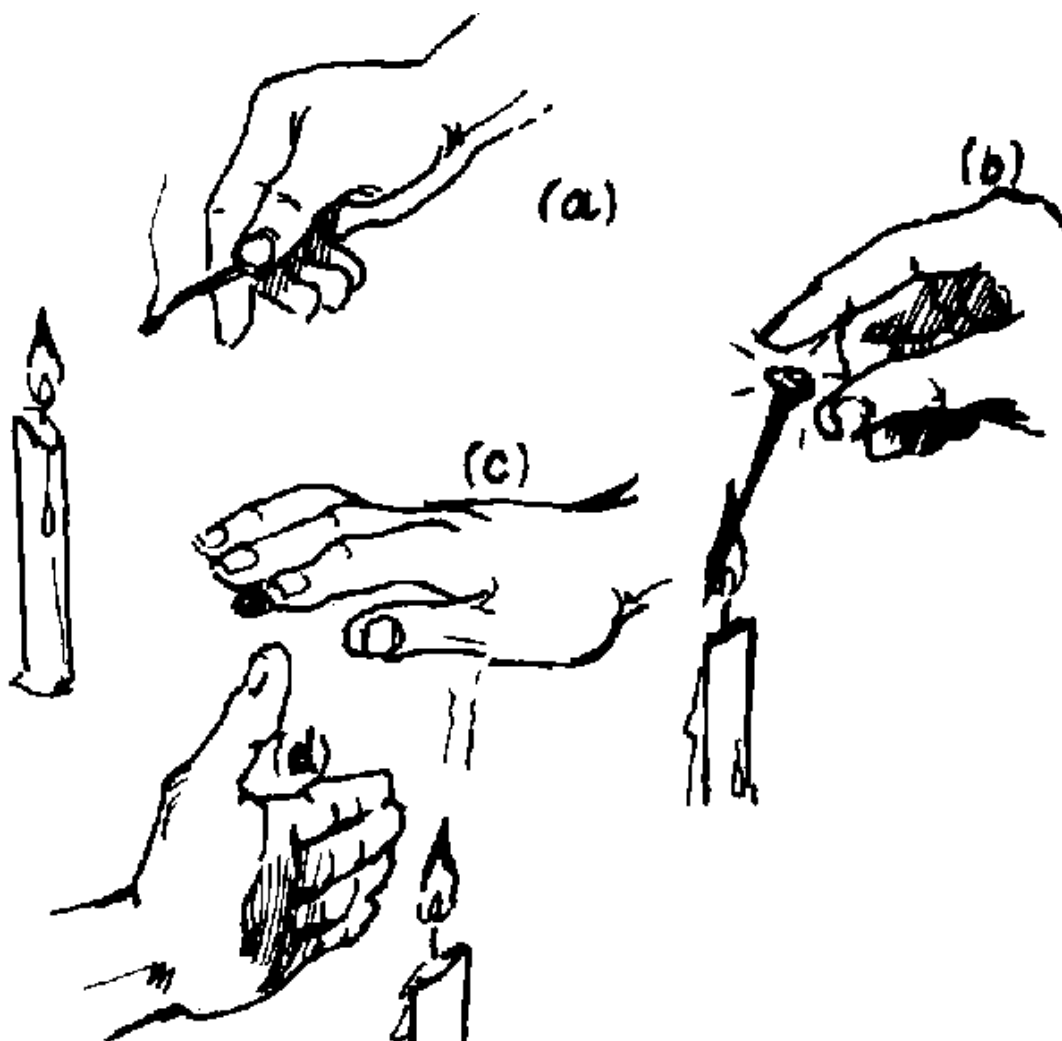

**P:** (a) Light a candle and demonstrate three ways of heat transfer by a simple hand experiment.

(b) *Conduction:* Stick one end of a nail into the flame.

**Q:** What do you feel?

(c) *Convection:* Place your hand at a distance above the flame.

**Q:** What do you feel?

(d) *Radiation:* Place your hand at the same distance on the side of the flame.

**Q:** What do you feel?

**O:** In each case heat is transmitted to your hand.

**P:** To check the *amount of heat transferred per unit time* by convection and radiation, hold a new match stick above and on the side of the flame and find out how long it takes to ignite the match stick in each case.

**H:** Any burner can be used instead of the candle. Non-luminous flames will produce the best results.

### 5.4.3 Solids as Conductors

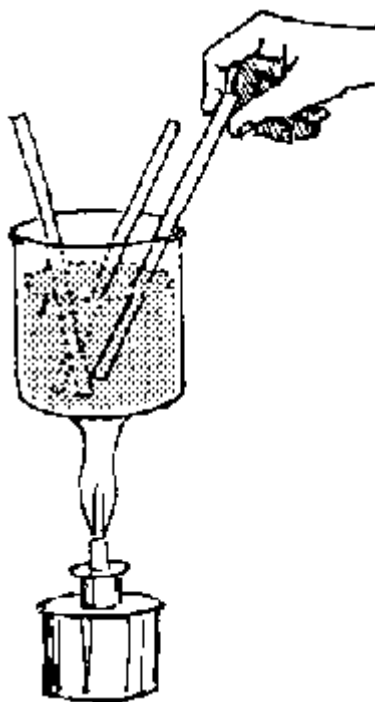

**P:** Heat water in a container until it is about to boil. Place metal, wooden and plastic rods of the same dimensions vertically into the water. Touch the exposed ends of the rods after 3, 4 and 5 minutes.

**Q:** What do you conclude about the conductivity of each rod?

**E:** The metal rod is a good conductor but the plastic and wood are bad conductors.

**A:** Plastics and wood are used as handles of saucepans; the saucepans and other cooking pots are best made of good conductors of heat e.g. metals.

### 5.4.4 Conduction by a Metal Rod

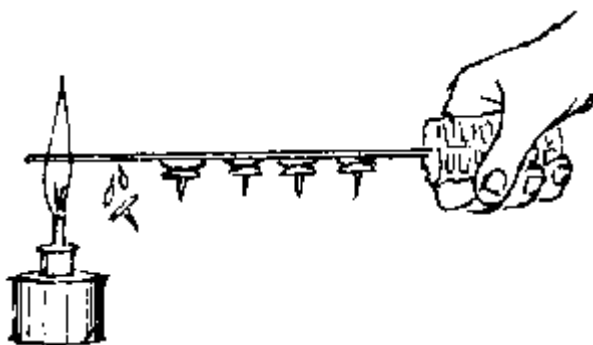

**P:** Fix several small stones with molten candle wax along a metal rod at a regular interval. Heat one end of the rod.

**Q:** What do you observe?

**E:** The stones will fall off one after another starting from the end being heated, because heat is conducted slowly along the rod from the heated end.

### 5.4.5 Liquids as Conductors

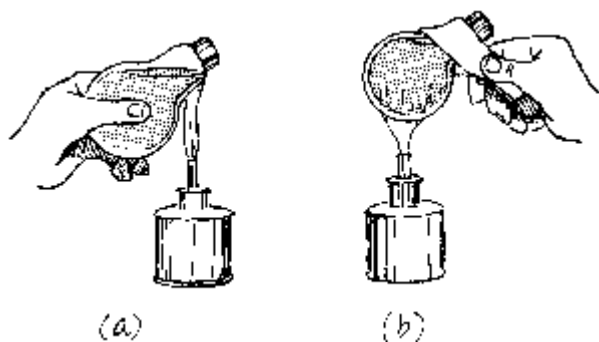

**P:** Fill a test tube or an opened bulb (see appendix) with water. Heat the water just below the top. Feel the bottom of the test tube with your hand, see figure (a).

**Q:** Explain what you feel.

**E:** The bottom of the test tube stays cold because water is a bad conductor and does not conduct the heat to the bottom.

**Q:** What would happen if you held the test tube at the top and heat it at the bottom? (see figure (b)).

### 5.4.6 Convection of Heat

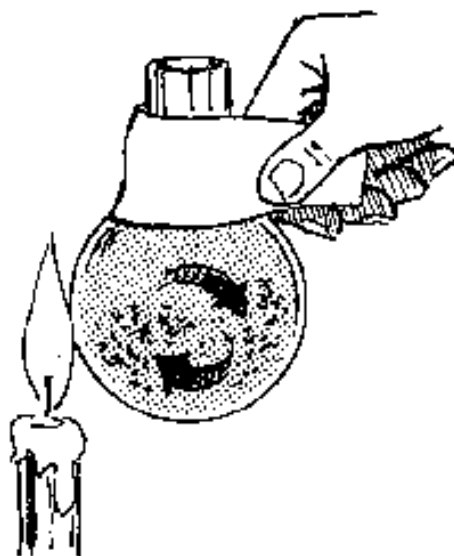

**P:** Fill a round flask or opened bulb (see appendix) up to the neck with water. Sprinkle a pinch of fine saw dust on the water. Heat one side of the flask only.

**Q:** What do you observe in the flask?

**E:** You will see a *convection current* being formed in the flask. The warm water rises and the cooler water sinks down to the bottom as seen by the movement of the saw dust.

#### 5.4.7 Breeze as a Convection Current

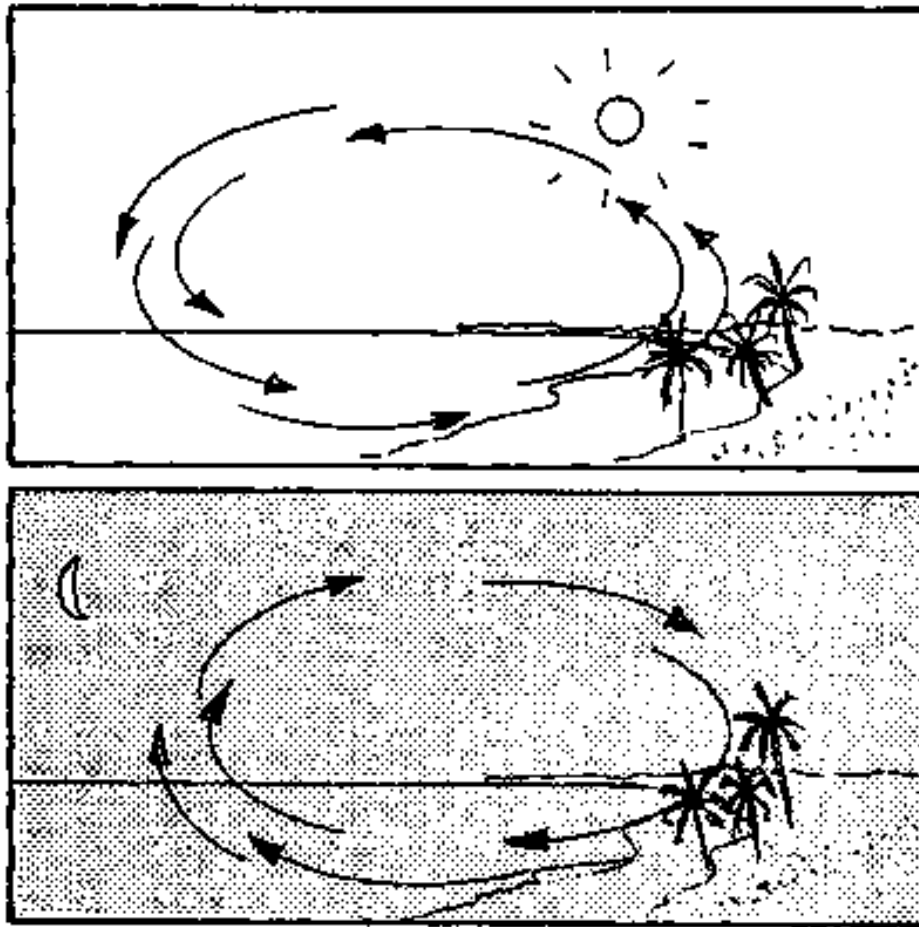

**O:** At the coast and on lake shores a gentle air stream (breeze) always blows. The direction of the breeze during the day is different from that at night.

**Q:** How can you explain this?

**E:** *During daytime* the land warms up faster than the sea. The warm air rises over the land and colder air from the sea flows to the land. This creates a breeze from the sea to the land. *During night*, the water stays warmer than the land, air over the water rises, colder air from the land flows to the sea. This creates a breeze from the land to the sea. The general effect is that the breeze from the sea keeps the daytime temperature on the land lower than expected from the hot sun, whereas the breeze from the land makes the night temperatures cooler than expected.

### 5.4.8 Good and Bad Radiators

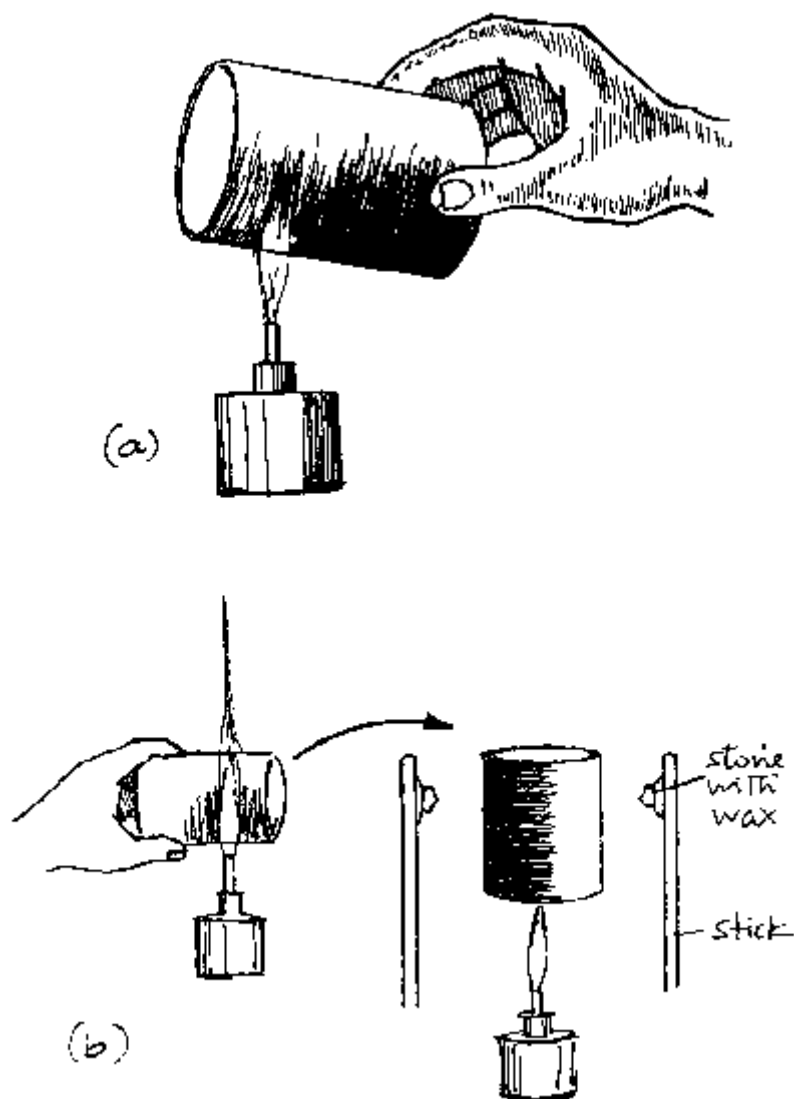

**P:** Paint one half of the outside of an open can black and leave the other half shiny (see figure (a)). Place a wooden stick near each side of the can. Stick a small stone with candle wax on each stick. Heat the bottom of the can.

**Q:** What do you observe?

**E:** The candle wax opposite the blackened surface begins to melt earlier than the wax opposite the shiny surface. This shows that *a black surface is a better radiator than a shiny surface.*

**H:** Soot and black shoe polish will do for the black paint.

#### 5.4.9 Good and Bad Heat Absorbers

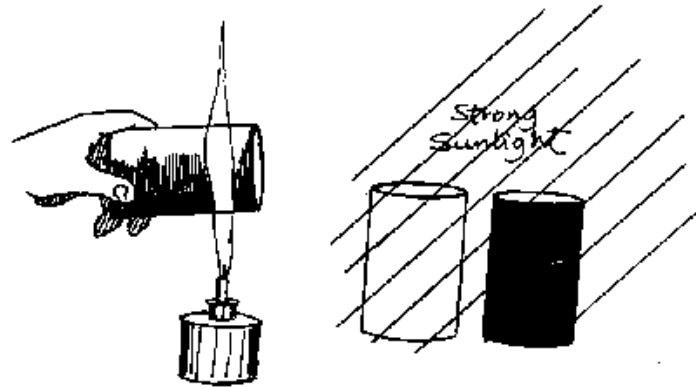

**P:** Take two shiny and identical cans and paint the outside of one black (soot can do). Place both of them in the sun or place them at equal distances from a fire for some time (about half an hour). Then find out how hot each can feels.

**Q:** Which can heats up more quickly?

**E:** The can with a *black surface* absorbs heat more quickly than the one with a *shiny surface*.

**A:** It is wiser for people in hot areas to wear bright clothes and paint their houses white - so that they absorb less heat. What colour should a petrol tank be painted? Give your reasons.

#### 5.4.10 The Thermos Flask

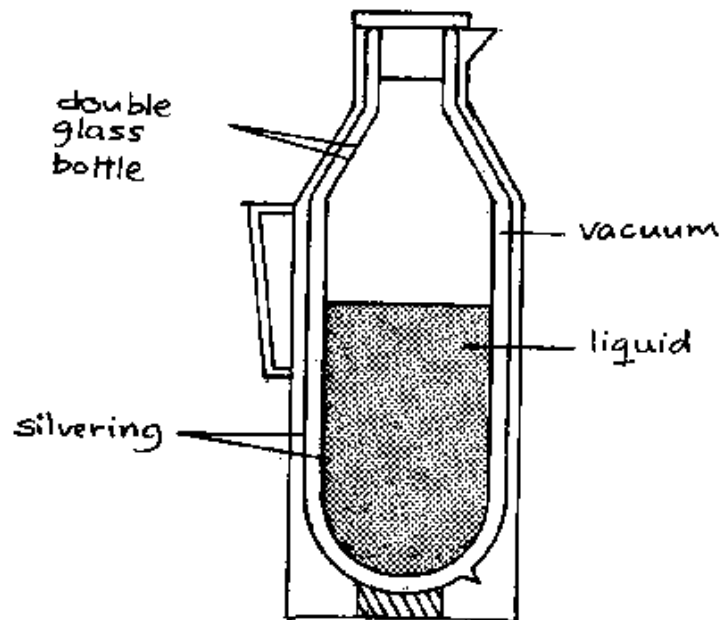

**P:** The thermos flask is a double walled glass bottle with a vacuum between the walls. Both the inner and outer surfaces of the walls are silvered so that they are shiny.

**Q:** How does the flask keep hot tea hot or cold water cold?

**E:** A vacuum is a bad conductor of heat and does not allow convection of heat. The vacuum prevents heat loss or gain by conduction and convection. The silvery walls reduce heat absorption and heat loss by radiation.

## 6. Wave Motion

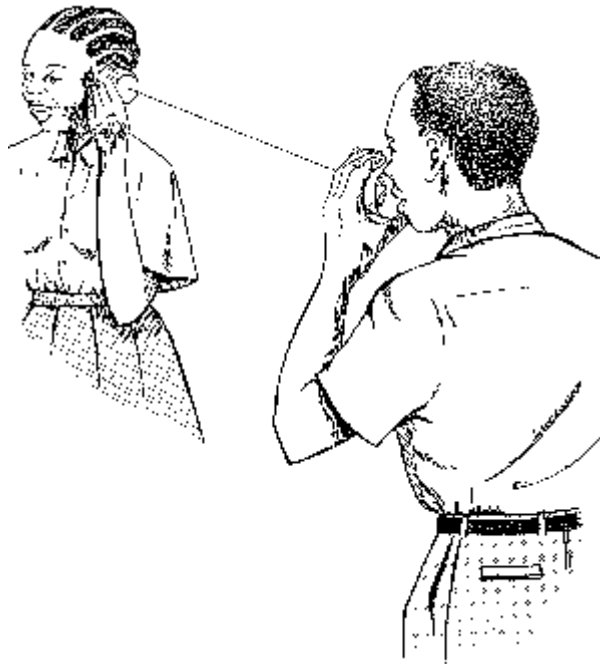

### 6.1. Production of Waves

If a stone is dropped in a still pool of water, concentric circles spread out from the point where the stone enters the water. These concentric circles are an example of a travelling disturbance. A travelling disturbance is called a wave.

In *transverse waves* (e.g. water waves) the vibration of the particles is *perpendicular* to the direction of the propagation of the waves. In *longitudinal waves* (e.g. sound waves) the vibration of the particles is *in the direction* of the propagation of the waves.

Only *energy is transported by a wave*. The oscillating particles of the medium, which transmits the wave, do *not* travel with the wave.

The *frequency* gives the *number of oscillations per unit time*.

#### 6.1.1 Transverse Wave Using a Rope

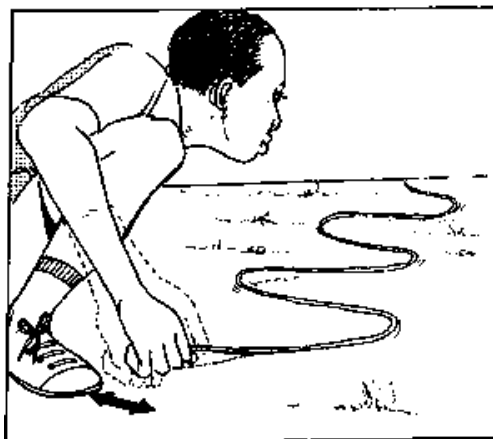

**P:** Take a piece of rope of about 6 m length. Hold it at one end and jerk it sideways.

**Q:** What do you observe? Draw a sketch.

**E:** The disturbance produced by jerking travels along the rope making *crests* and *troughs*. The jerking of the rope acts as a source of disturbance which travels along the rope. The direction of motion of the wave is *perpendicular* to the direction of jerking. Thus is a *transverse wave*.

### 6.1.2 Tracing a Wave Using a Pendulum Container

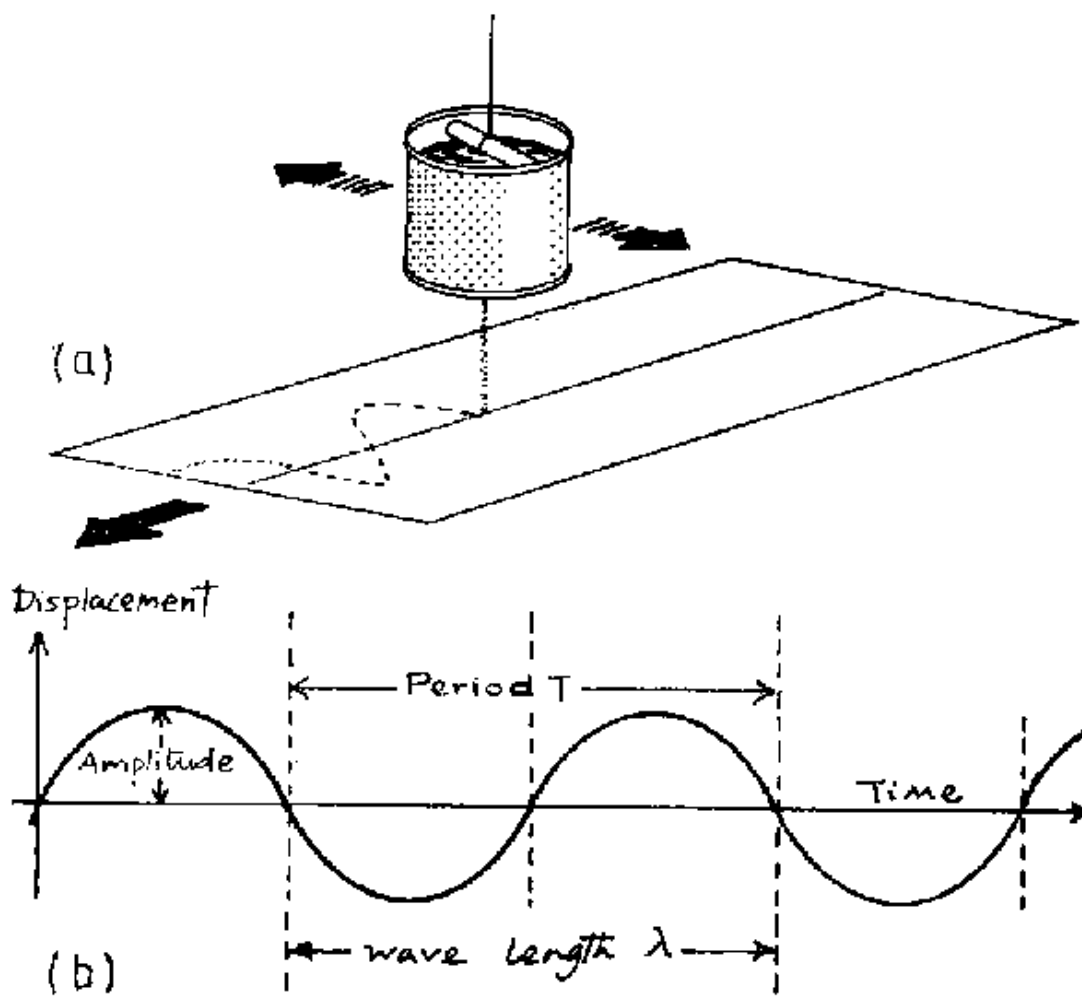

**P:** Take an empty tin opened at one end. Make a small hole at the other end using a sharp nail. Suspend it using a string so that the bored end faces downwards. By gluing or pinning prepare a 30 x 200 cm sheet of an old newspaper. Fill the suspended tin with coloured water (e.g. using ink) or fine sand (dry). Pull the tin to one side and leave it to oscillate freely. While it is oscillating steadily, pull the paper under the tin with *constant velocity*.

**Q:** What do you observe? Draw a sketch.

**E:** When the tin is pulled sideways, it tries to go back to the equilibrium position and overshoots. As it oscillates the jet from the tin draws a sinus trace on the paper passing underneath it. The resulting trace shows a *transverse wave*.



### 6.1.3 Sound from a Ruler

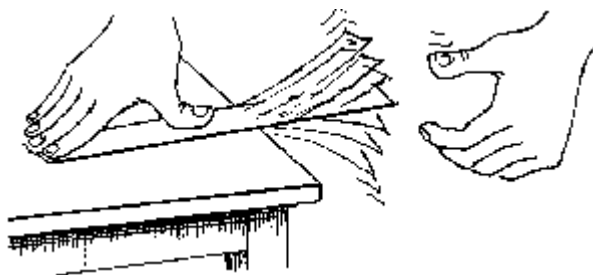

**P:** Clamp a ruler on a table with its free end protruding. Cause the free length to vibrate and listen to the sound. Repeat this for different protruding lengths of the ruler. Four different lengths are enough.

**Q:** How does the sound and vibration relate to the protruding length of the ruler?

**E:** When the vibrating length is reduced, a higher pitch sound is heard and the vibrations become faster and faster. When the vibrating length is increased, a lower pitch sound is heard and large masses of air are set into vibration with large amplitude. Consequently a loud sound is heard. Conversely, short lengths cause small masses of air to vibrate with small amplitudes producing a low sound.

### 6.1.4 A Transverse Pendulum

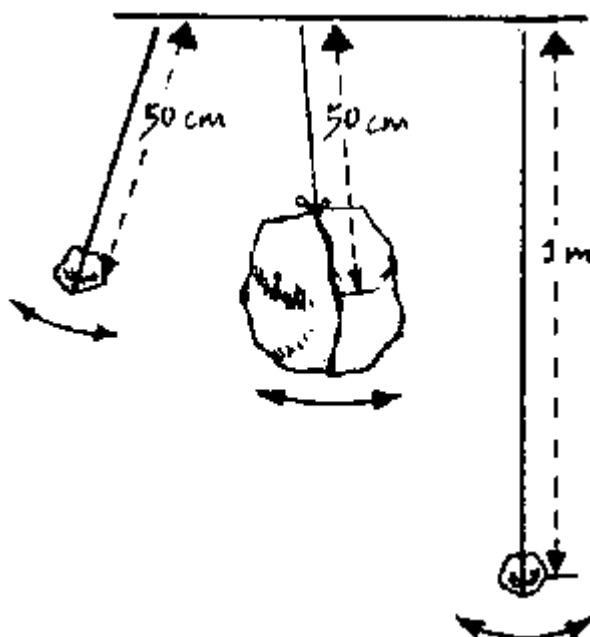

**P:** Tie a stone to one end of a thread of 50 cm length. Fix the other end of the thread and cause the pendulum to oscillate. Make sure that the displacement is not more than  $10^\circ$ . Record the time for 20 oscillations and find the frequency. (Frequency = number of oscillations  $\div$  time taken). Change the stone to a heavier one and repeat the procedure. Change the length of the thread to 100 cm and repeat the procedure.

**Q:** What do you find?

**E:** The frequency is independent of the mass, but depends on the length of the thread.

### 6.1.5 A Longitudinal Pendulum

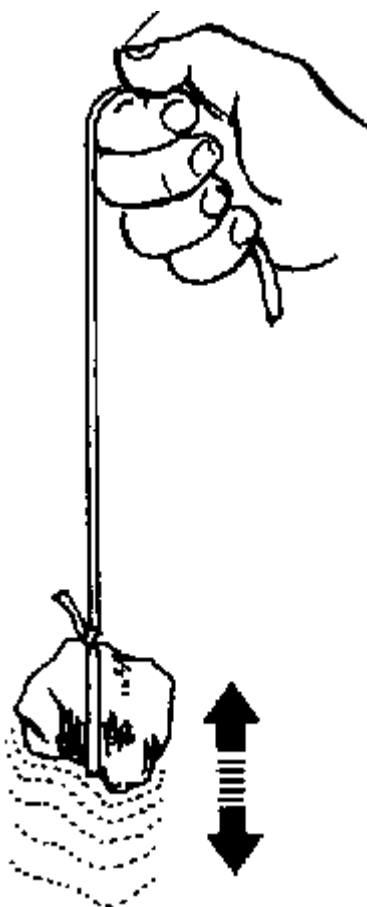

**P:** Tie a stone to one end of a rubber band and hold the other hand as shown above. Lift the stone up and release it so that it oscillates. Record the time for 20 oscillations. Find the frequency. Repeat the procedure by varying the length of the rubber band and the mass of the stone.

**Q:** What do you observe?

**E:** The frequency is independent of the mass but depends on the length.

### 6.1.6 Sound Vibrations



**P:** Cover one end of an open tin with a membrane (paper). Fasten it using a string. Spread fine dry sand on the membrane. Speak a soft and a loud sound from the bottom into the tin while your friend is watching the sand.

**Q:** What does he/she observe?

**O:** The louder the sound, the larger the amplitude of the vibrations.

**E:** The air underneath the membrane has been disturbed by the sound waves which in turn disturb the membrane and make it vibrate. This experiment shows that sound travels as a vibration.

### 6.1.7 Knocking a Water Tank

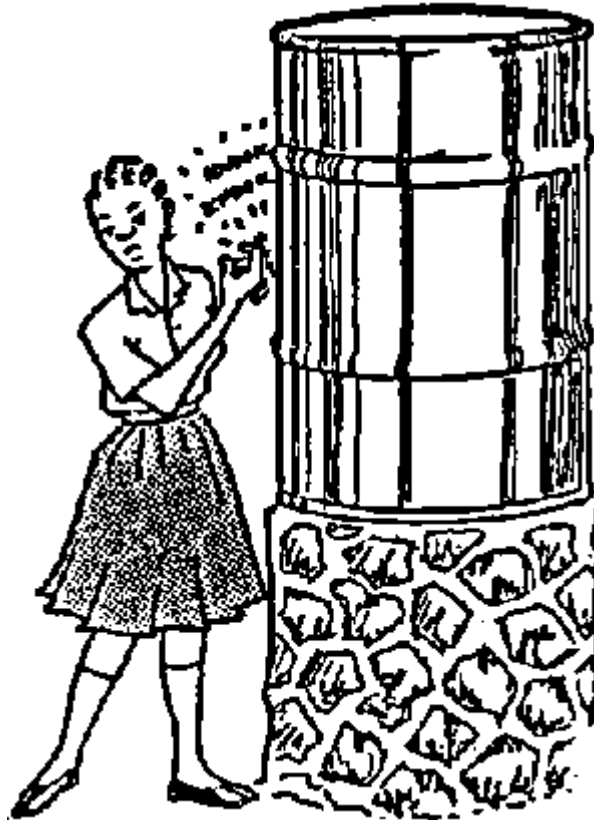

**P:** Gently knock the side of a wa(...)um from the top downwards to the bottom and listen to the tones (see the figure).

**Q:** What do you hear?

**O:** The knock causes the drum to vibrate. At the top, the knocking sets air inside the drum into vibrations giving a loud sound; at the bottom the knocking sets water inside the drum into vibrations giving a soft sound.

**A:** This can be used to check the presence of liquids in tanks or larger containers.

### 6.1.8 Waves on a Water Surface



**P:** Allow the surface of coloured water in a bucket to come to rest. (Ink can be used to colour the water.) Fill a plastic bag with water and make a small hole at its bottom. Raise the bag so that drops of water fall on the surface of the coloured water.

**Q:** What do you observe?

**O:** You will see circular waves spreading out rapidly. The drops disturb the water. The disturbance spreads out in concentric circles from the centre. The concentric circles observed are water waves.

### 6.1.9 Transfer of Energy

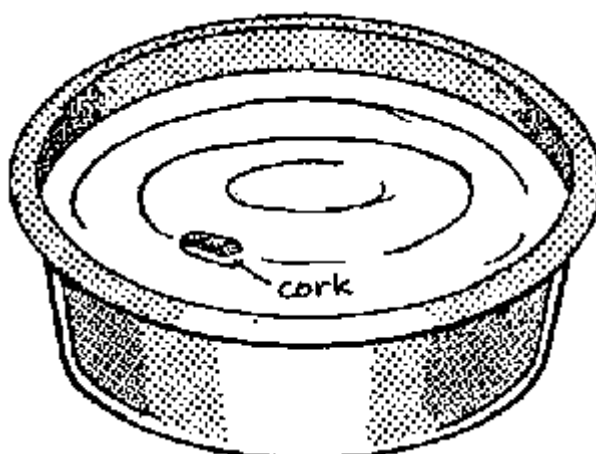

**P:** Put a small piece of light material (e.g. light wood, polystyrene) on the surface of water in a bowl. With a dropper (see 6.1.8) release a few drops of water onto the centre of the water surface. Avoid wind.

**Q:** What do you observe?

**O:** You will see water waves moving from the centre outwards but the pieces of light materia will not travel with the waves.

**E:** Energy travels with the wave. However, the particles of the wave-transmitting medium (e.g water) do *not* travel with the wave, they only oscillate up and down.

### 6.1.10 Transfer of Energy

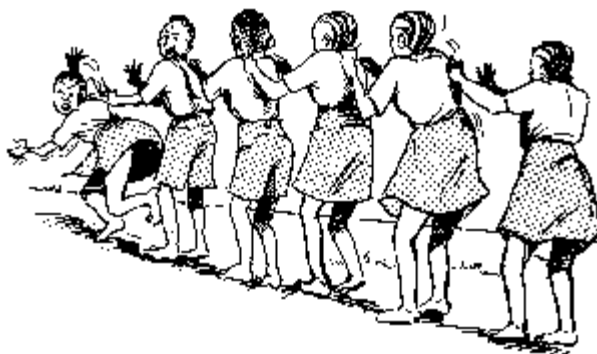

**P:** Line up a group of students and ask each student to place his/her hands on the shoulder of the student in front with the elbows kept bent. Tell the last student to push forward.

**Q:** What do you observe when one after the other student pushes?

**O:** A longitudinal wave moves through the queue.

## 6.2 Propagation of Waves

Sound does not travel through a vacuum but it requires a *medium* for its propagation. Denser media are better transmitters of sound than less dense media.

Thus, sound travels faster and better in water, wood or strings of various materials than in air.

### 6.2.1 The String Telephone

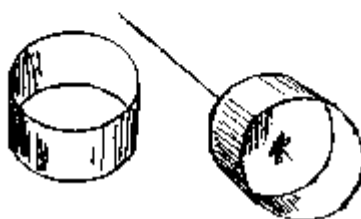
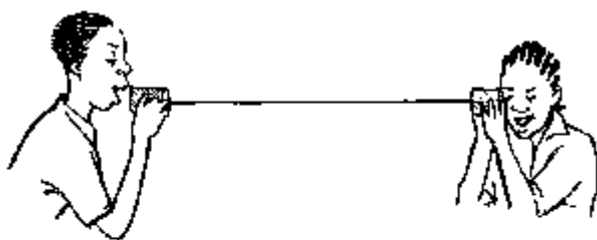

**P:** Punch a small hole at the centre of the bottom of each of the two empty cans. Connect the cans with a long string knotted inside each can. Hold the cans so that the string is stretched. Talk into one can while your friend is listening (he/she may close the other ear with a finger). Ask your friend to talk to you also and listen to him.

**Q:** What do you hear?

**O:** You will hear each other distinctly. Sound has travelled through the string (as a medium) from one can to the other.

### 6.2.2 Sound Waves in Air

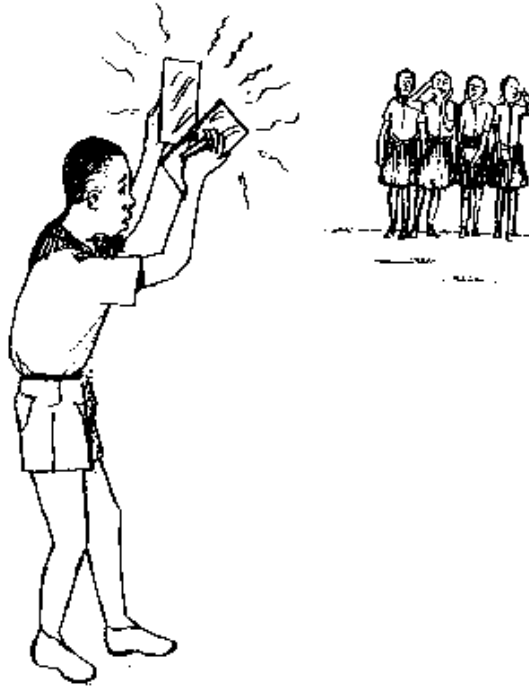

**P:** One student is standing about 100 m from the class and making sound by clapping two metal pieces (two lids) together.

**Q:** What do you hear?

**O:** You will hear a sound. The sound you hear has been transmitted from the source to you by air as a medium.

### 6.2.3 Sound in a String

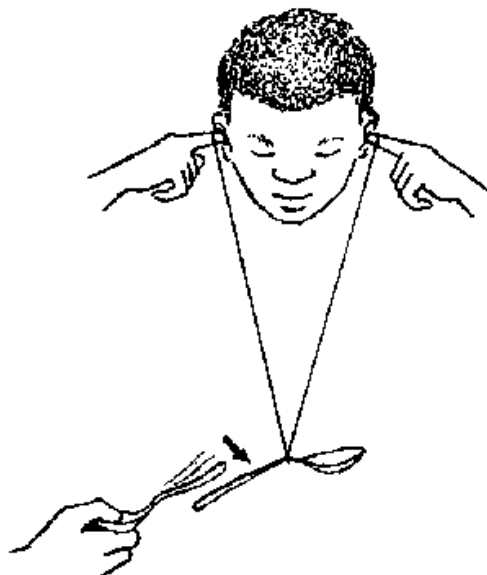

**P:** Tie a metallic teaspoon at the middle of a one metre long cotton thread. Wind each end of the thread around a fingertip (see figure). Press the fingertips into your ears. Bend down so that the string and the spoon hang freely. Let someone hit the spoon slightly with a nail or another spoon. Listen to the sound.

**O:** You will hear a chime sound like that of a church bell.

**E:** Sound travels through the string to your ears. Sound travels better in strings than in air.

#### 6.2.4 Sound in Wood

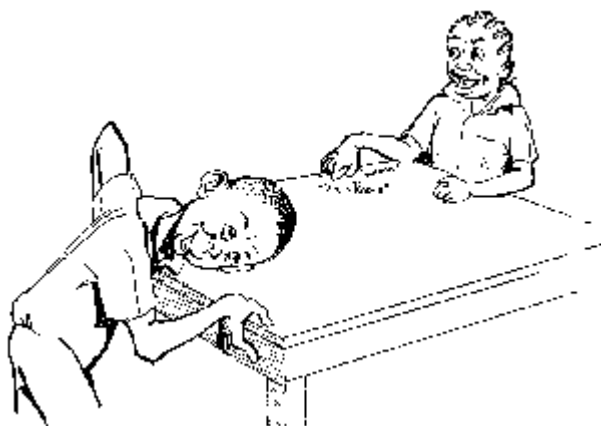

**P:** Place your ear against one edge of a table while your friend is knocking the opposite edge slightly. Repeat the experiment by scratching the table slightly. Listen to the sound through air and the sound through the table.

**Q:** Describe what you hear.

**O:** The sound travelling through the table is heard more distinctly than when heard through the air.

**E:** Hence sound travels better in wood than in air.

#### 6.2.5 Sound in Metal

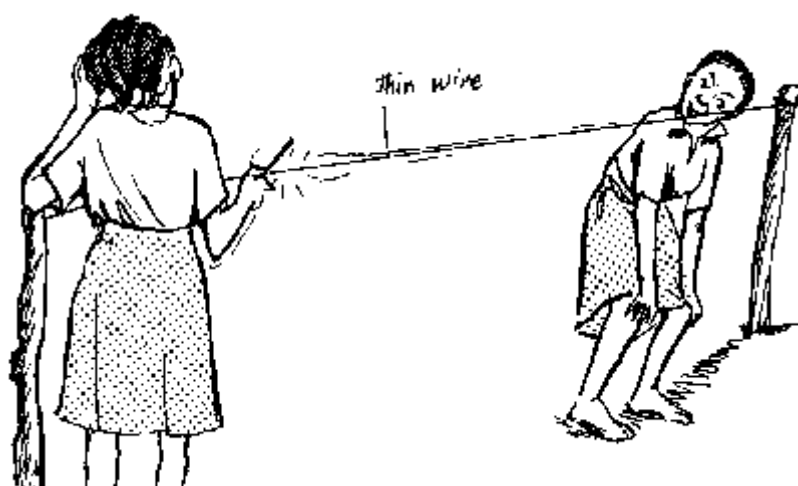

**P:** Take a long thin wire and fix it to two posts placed about 5 m apart. Tell your friend to be at one end. Then scratch the other end of the wire. Scratch the wire again while your friend has placed his/her ear against the wire on his/her side.

**Q:** Ask your friend what he/she hears.

**O:** Your friend will hear nothing unless he/she places his/her ear against the wire.

**E:** Sound travels better in metal than it does in air.

### 6.2.6 Sound in Water



**P:** Fill a plastic bucket with water. Take two stones and knock them against each other *in the water*, while another person has put his/her ear close to the bucket.

**Q:** What does he/she hear?

**O:** He/she will hear the sound coming through the water more loudly.

**E:** Sound travels better in water than in air.

### 6.3 Reflection of Waves

When a travelling wave meets a smooth barrier it is reflected. When a wave is reflected, the angle of incidence is equal to *the angle of reflection*.

When a wave is constantly reflected the same way back as it comes to the obstacle (e.g. a wave reflected on the fixed end of a string), a *standing wave* is produced.

Reflected sound is called an *echo*. Ships use *echo-sounding* to determine the depth of the ocean.

#### 6.3.1 Reflection of Water Waves

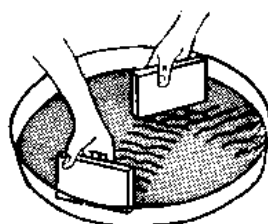
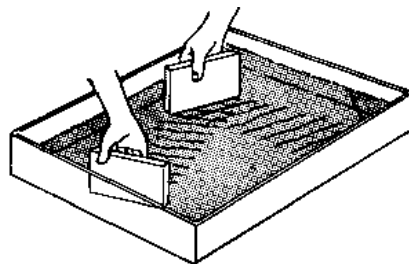



**P:** Place a straight metal or plastic barrier in the dish containing coloured water. Touch the surface of the water with a rectangular block of wood repeatedly in equal time intervals.

**Q:** What do you observe?

**O:** Parallel waves move across the dish and rebound from the barrier.

**E:** This behaviour is known as *reflection of waves*. When the angle of inclination of the barrier is changed, the angle of reflection remains the same as the angle of incidence. The barrier is acting as a reflector just as a mirror is a reflector of light.

### 6.3.2 Reflection of Sound Waves

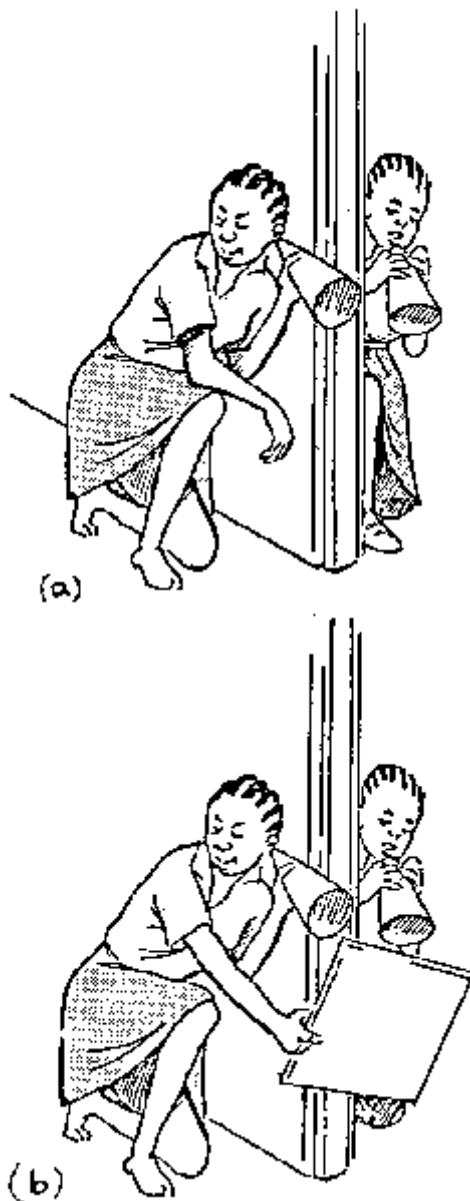

**P:** You and your friend should stand on both sides of a wall beside an opened door. Ask your friend to whisper into a cone and listen through the other cone, see figure (a).

**Q:** Do you hear anything?

**O:** No sound is heard.

**P:** Repeat the above procedure while holding a smooth cardboard as shown in figure (b). Change the position of the smooth cardboard.

**Q:** What do you hear?

**O:** Distinct sound is heard. This is because the whispered sound has been reflected by the smooth cardboard towards the listener.

### 6.3.3 Reflection in a Rope

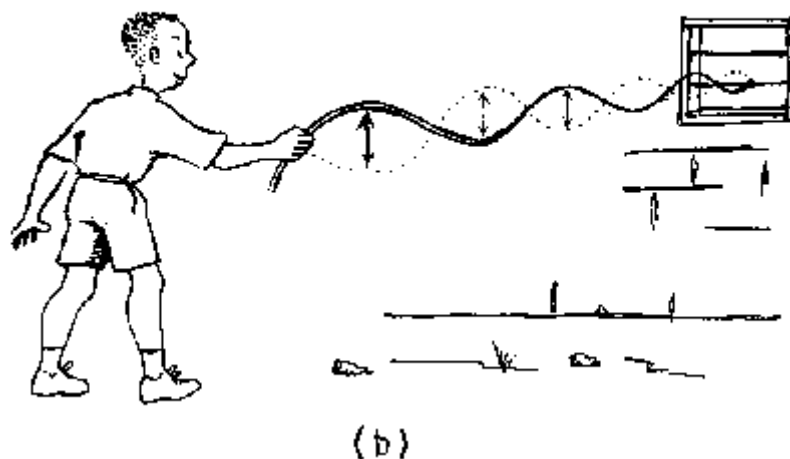
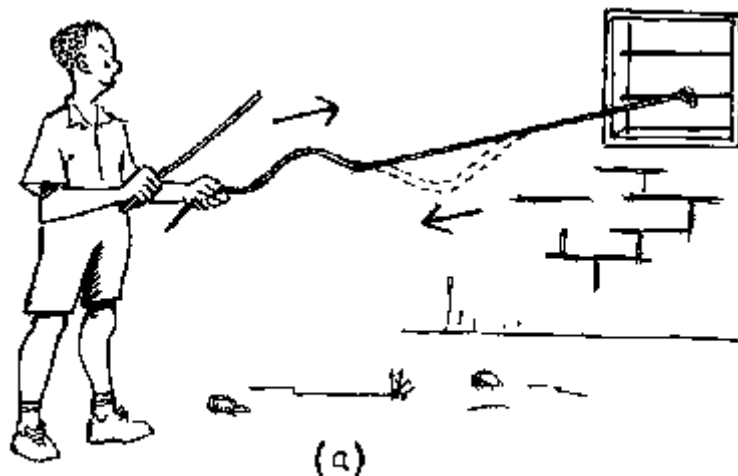

**P:** Tie a rope of about 4 metres length on a fixed bar of a window as shown in the diagram. Hit the rope by a stick.

**Q:** What do you observe?

**P:** Repeat the procedure above by jerking the rope up and down.

**Q:** What do you observe now?

**O:** (a) An impulse travels along the rope and comes back.

**E:** When the impulse hits the fixed end of the rope, it bounces off and comes back again as shown by the dotted line in the diagram. The reflected impulse has the same shape as the

incident impulse, but is inverted, see figure (a). ? Thus, when a wave is reflected on the fixed end of the rope, a *standing wave* is produced, see figure (b).

### 6.3.4 Reflection in a Hose Pipe



**P:** Take a long piece of an empty garden hose pipe. Listen at one end of the pipe while your friend is whispering into the other end of the pipe.

**Q:** What do you hear?

**O:** The sound is heard more distinctly.

**E:** When your friend is whispering,, he is sending sound waves into the pipe which are reflected on the walls of the hose pipe. These waves are directed to the other end of the hose pipe where they can be heard.

**A:** Similarly light can be reflected in a glass fibre. Thus, light pulses may be transmitted by glass fibres. This is used for telephone television etc.

### 6.3.5 Reflection of Sound Waves: Echoes

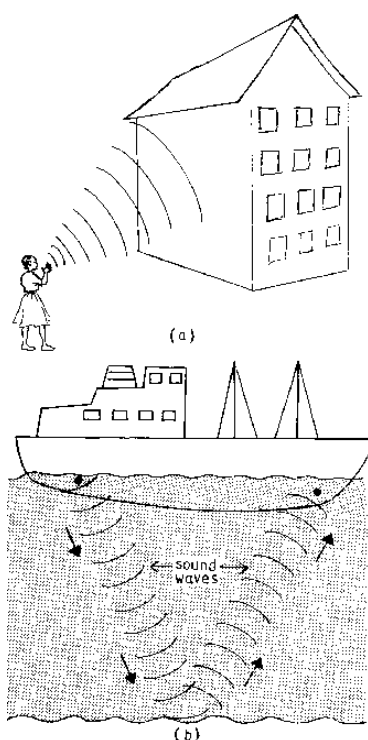

**P:** Stand near a tall building and call out loudly, see figure (a).

**Q:** What do you hear?

**O:** After a short time, the call is heard again.

**E:** The sound waves have been reflected from the wall of the building. The reflected sound which is heard is called an *echo*.

**A:** Echoes are used by bats in (ultra sound) navigation. Also echoes are used to determine shoals of fish and the depth of oceans, a phenomenon called *echo-sounding* see figure (b).

### 6.3.6 Reflection of Sound Waves

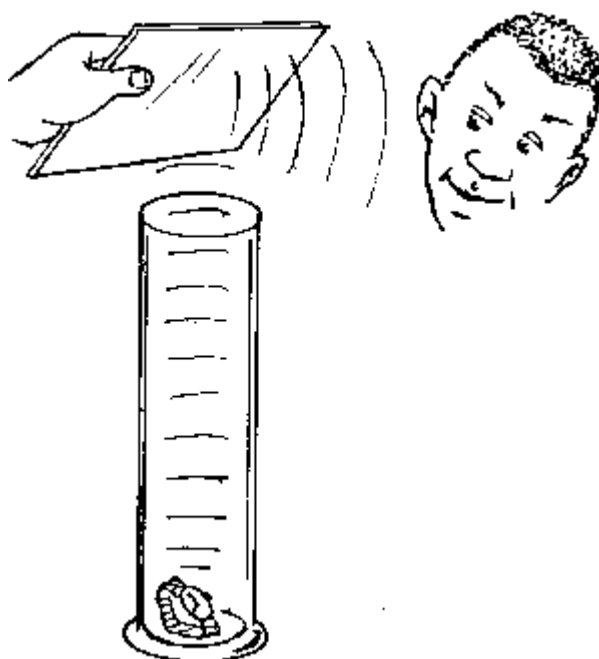

**P:** Take a tall cylindrical container and put a mechanical clock in it. Place your ear close to the side of the container. Listen to the sound from the clock. Then place a cardboard at slant position about 5 cm on top of the container and listen again (change the position of the board).

**Q:** What do you hear?

**O:** In the absence of the cardboard no sound is heard. But in the presence of the cardboard the tick-tack sound is heard.

**E:** This is because the sound from the clock travels vertically up and is reflected by the cardboard towards the observer.

### 6.4 Music and Musical Instruments

The human voice is produced by the vibration of the vocal cords. Changes in tension and length produce changes in pitch or tone of the voice. *The less the length and the higher the tension of a cord, the higher the pitch of the tone produced.* The same principle is used to produce music with a *guitar* or a *violin*. The *marimba* and the *xylophone* use sticks or bars of various length or thickness to produce tones of different pitch. The *flute*, the *bottle orchestra* and the *organ* use air columns of various length.

### 6.4.1 Sonometer (One - String Guitar)

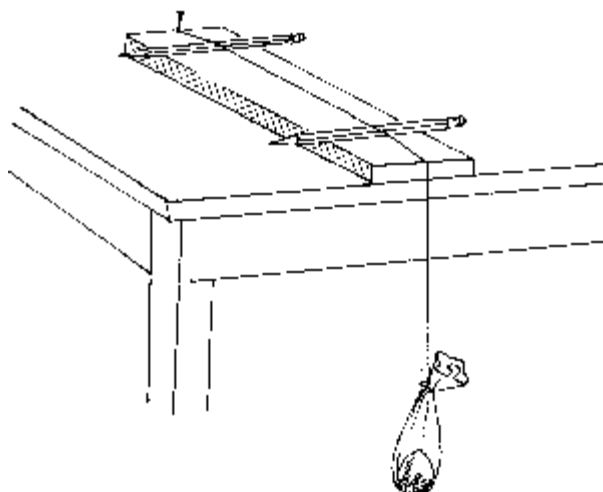

**P:** Place a soft board on a table. Fix a string with a nail to one end of the soft board. Tie the heavy mass of a stone to the other end of the thread so that the mass hangs below the edge of the table. Insert two pencils under the thread so as to raise the thread off the board. Pluck the thread between the two pencils. Vary

- (a) the distance between the two pencils;
- (b) the mass hanging.

**Q:** What do you hear?

- O:** (a) A higher tone is produced if the distance between the two pencils is reduced.  
(b) A higher tone is produced if the mass is increased.

**E:** The tone which is produced by the vibrating string depends on its vibrating length and the tension of the string.

### 6.4.2 Bottle Orchestra



**P:** Take four equal bottles. Leave the first bottle empty. Fill the second bottle a quarter of its volume, the third a half, and the fourth three quarters of its volume with water and blow into

the bottles one after another and listen to the tones produced.

**Q:** Do you notice any difference in sound?

**O:** The shorter the air column the higher the tones.

**A:** The organ (used in some churches); the flute.

#### 6.4.3 Marimba

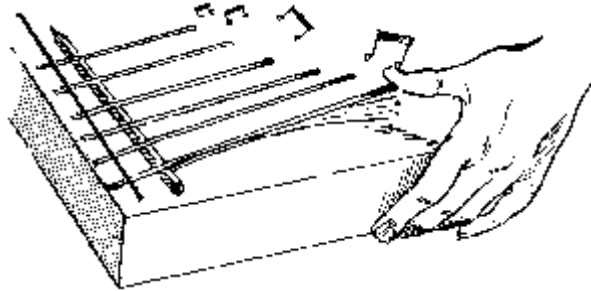

**P:** Cut bicycle spokes into different lengths. Arrange them on a piece of wood and fix them to it by putting another spoke across them as shown in the figure. Lift the fixed spokes by inserting a pencil under them to raise the free ends of the spokes off the wood. Pluck the free ends one after another and listen to the tones produced.

**Q:** What do you notice?

**O:** The plucking causes the spokes to vibrate and produce sound. The longer the spoke, the lower the tone.

**A:** Grand pianos produce lower notes than normal ones.

#### 6.4.4 Simple Flute (Bamboo Flute)



**P:** Take a straight bamboo tube of about 1.5 cm diameter and 30 cm length. Clean the knots inside. Dry it until its colour changes to yellowish-brown. Make a mouth-piece and a row of holes as shown in the figure. Blow air into the mouth-piece while closing some of the holes with your fingers.

**Q:** What do you hear?

**O:** Different tones are produced by the flute as you remove fingers from different holes.

The pitch of the tones depends on the distance of the first open hole from the mouthpiece, i.e. the closer the hole is to the mouth-piece, the higher the tone produced.

**E:** Thus, the tone produced is determined by the vibration of air in the column between the mouth-piece and the first uncovered hole.



#### 6.4.5 The Violin



**P:** Make two holes diametrically opposite each other near the upper open end of a tin and then pass a flexible wooden stick through them so that it just protrudes from the can on one side. Bore a small hole at the centre of the bottom of the can. Fix one end of a string at the hole and tie the other end to the end of the stick which is bent into a bow as shown in the diagram. Make the string tight. Pluck the string repeatedly with a finger as if playing a guitar.

(a) Change the tension by further lightening the string.

(b) Change the length of the vibrating portion of the string by touching the upper end with your finger.

**Q:** What do you hear?

**O:** (a) The pitch of the tone produced increases with the tension of the string.

(b) The pitch of the tone produced increases with the decrease of the length of the string.

**H:** Knotting the string on a nail held horizontally in the bottom of the can helps to anchor the string.

#### 6.4.6 The Xylophone



**P:** Make a wooden box with the bottom and the top side open. Take timber bars of different types and thickness. Drill four holes into each bar and pass two strings to hold all the bars together on the top of the open box. Beat the bars in turn by using two sticks.

**Q:** What do you hear?

**O:** Different sizes of bars give different tones and different types of materials of the same thickness give different tones.



## 7. Geometrical Optics

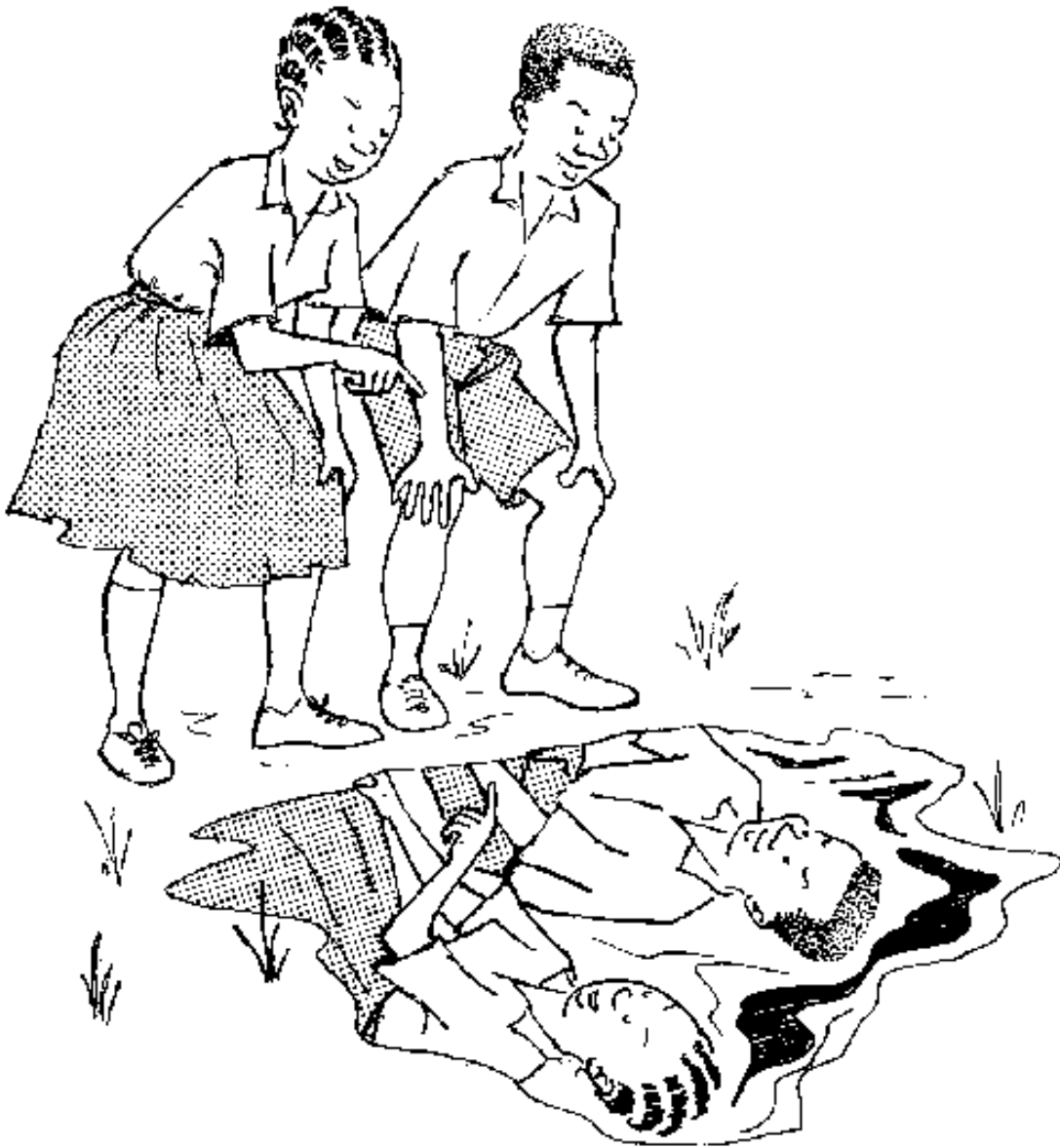

### 7.1 Nature and Propagation of Light

Light is the energy which is given off by very hot bodies in the form of electromagnetic waves and makes objects visible to our eyes. Light travels in straight lines. Thus, we may use *ray diagrams* in order to explain the *formation of the image in the pinhole camera* or the *formation of shadows* of an object.

### 7.1.1 Light Travels in Straight Lines

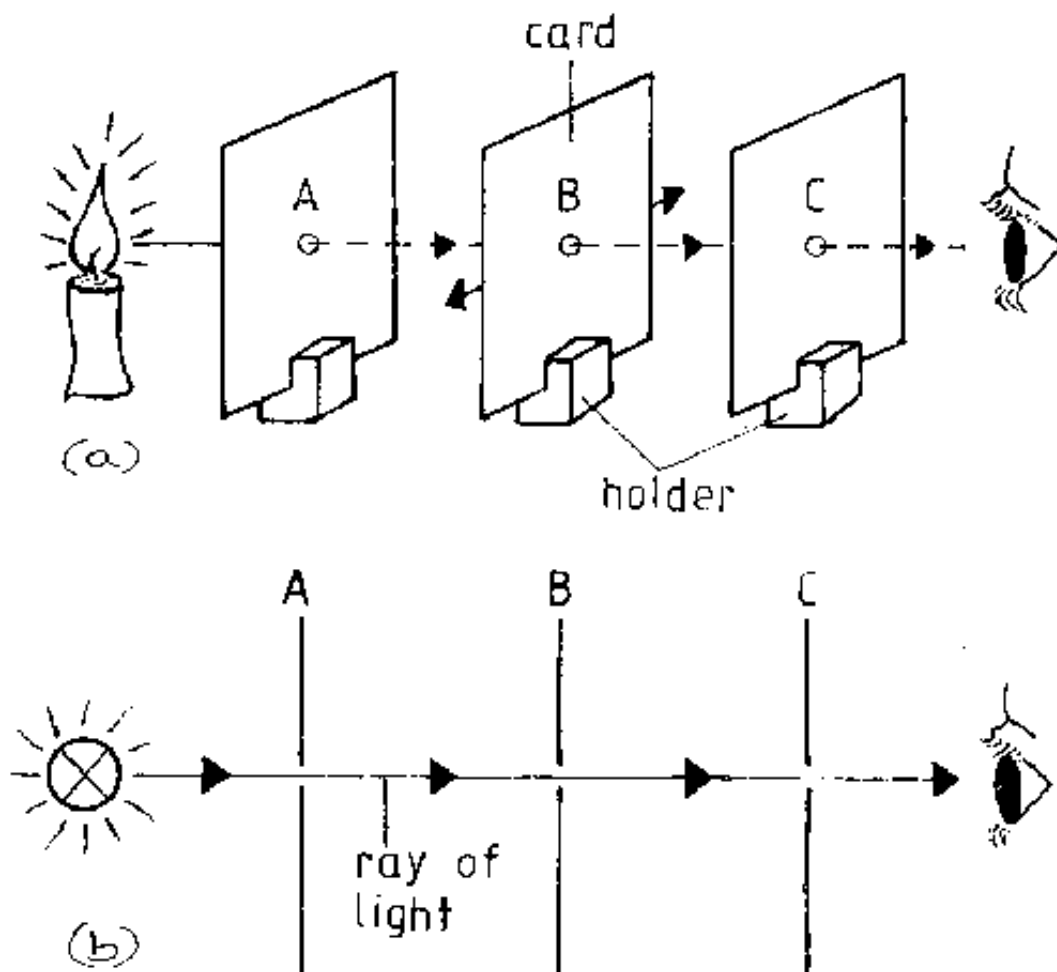

**P:** Make small holes on pieces of cardboard A, B and C. Place them in front of a source of light as shown. Pass a thread through the holes and pull it at both ends to make it taut. Adjust the cardboards so that all the three holes are in line. Remove the thread. Bring a candle near card A and look through the hole in card C. Record your observations.

Displace any one of the cards so that the holes are not in alignment.

**Q:** What do you observe? How can you explain this?

**E:** The light can be seen from end C only if all the three holes are in line. Displacing any of the cards obscures the ray of light and hence you cannot see the ray as you look from card C.

Hence *light travels in the straight lines*.

Figure (b) shows the same arrangement as figure (a) using symbols which are like the cross-section of the actual apparatus. We call such a figure a *ray diagram*.

### 7.1.2 The Pinhole Camera

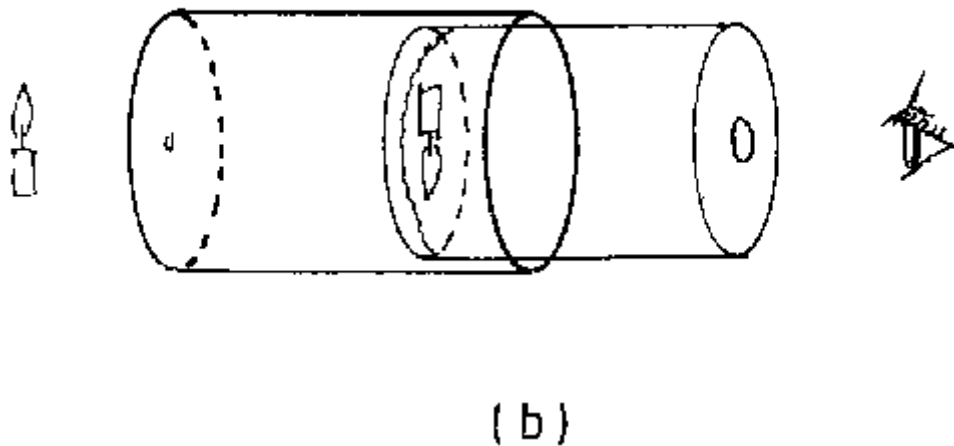
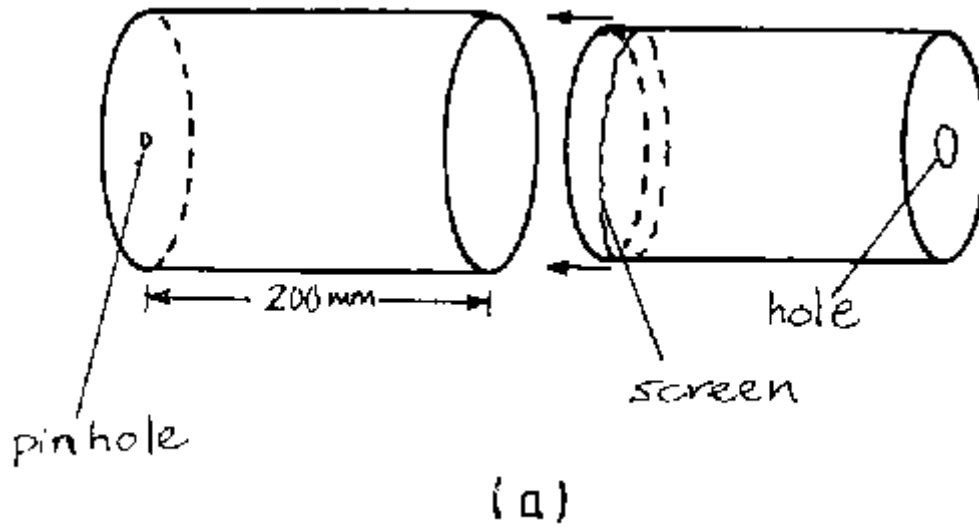

The pinhole camera is a camera made by using a tin or box with a pinhole at one end.

**P:** Roll a piece of manila card to make a cylinder. Glue a circular piece of card on one open end of the cylinder and puncture a hole at its centre using a pin. Make a second cylinder which fits tightly into the first cylinder. Cover one end of the second cylinder with a plain paper. The paper acts as a screen for the image which will be formed. Close the other end of this cylinder with a card. At the centre of the card produce a hole of about 2 cm diameter. Through this hole you will observe the image. The card prevents light to enter from this side because the image may be too dim to be seen, if light enters from the side of the observer.

### 7.1.3 Using a Pinhole Camera

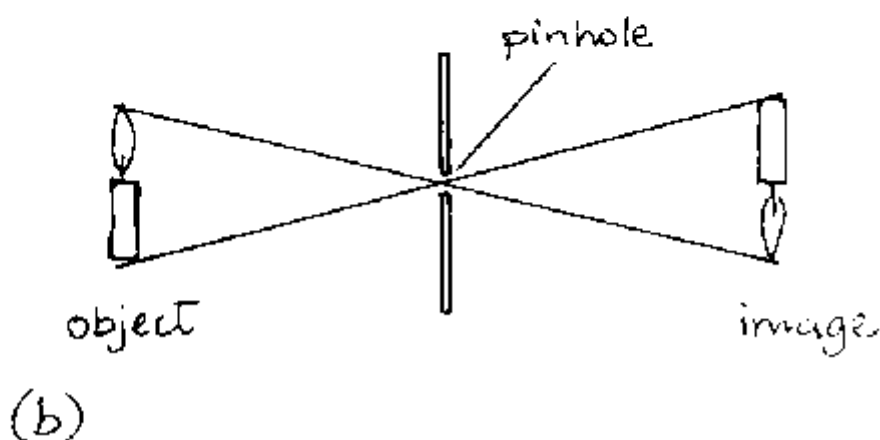
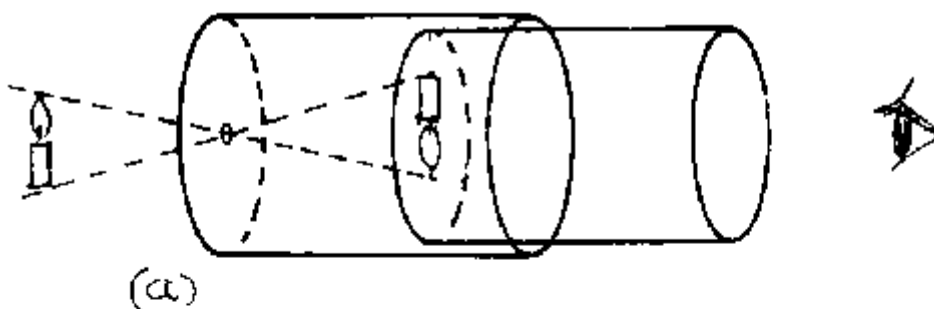

**P:** (a) Observe a burning candle using the pinhole camera. Adjust the pinhole-screen distance in order to get a clear, sharp image of the candle.

(b) Change the distance between the screen and the pinhole by steadily pulling the inner cylinder. Observe what happens to the image.

(c) Move the camera slowly away from the candle, and observe what happens to the image.

(d) Make the hole wider. Observe the image.

**E:** (a) The cone of rays reaching the pinhole from the object (candle) decreases with the distance of the hole from the object. Thus, the image becomes smaller and less bright. It is always an *inverted and real image*. An image is real if it can be caught by a screen, since the rays really meet in the various point of the image.

(b) When the distance between screen and pinhole is increased the image on the screen becomes larger and more blurred.

(c) The image becomes larger and more blurred when the object is closer to the hole and becomes smaller and sharper when the object recedes.

(d) When the hole is made larger the image on the screen becomes larger and more blurred. Generally, an optical image is sharp when all the rays, coming from one point of the object to the screen, meet at one point of the image. If the rays, coming from one point of the object to the screen, hit several points of the screen, the image is blurred.

### 7.1.4 Shadows Using one Light Source

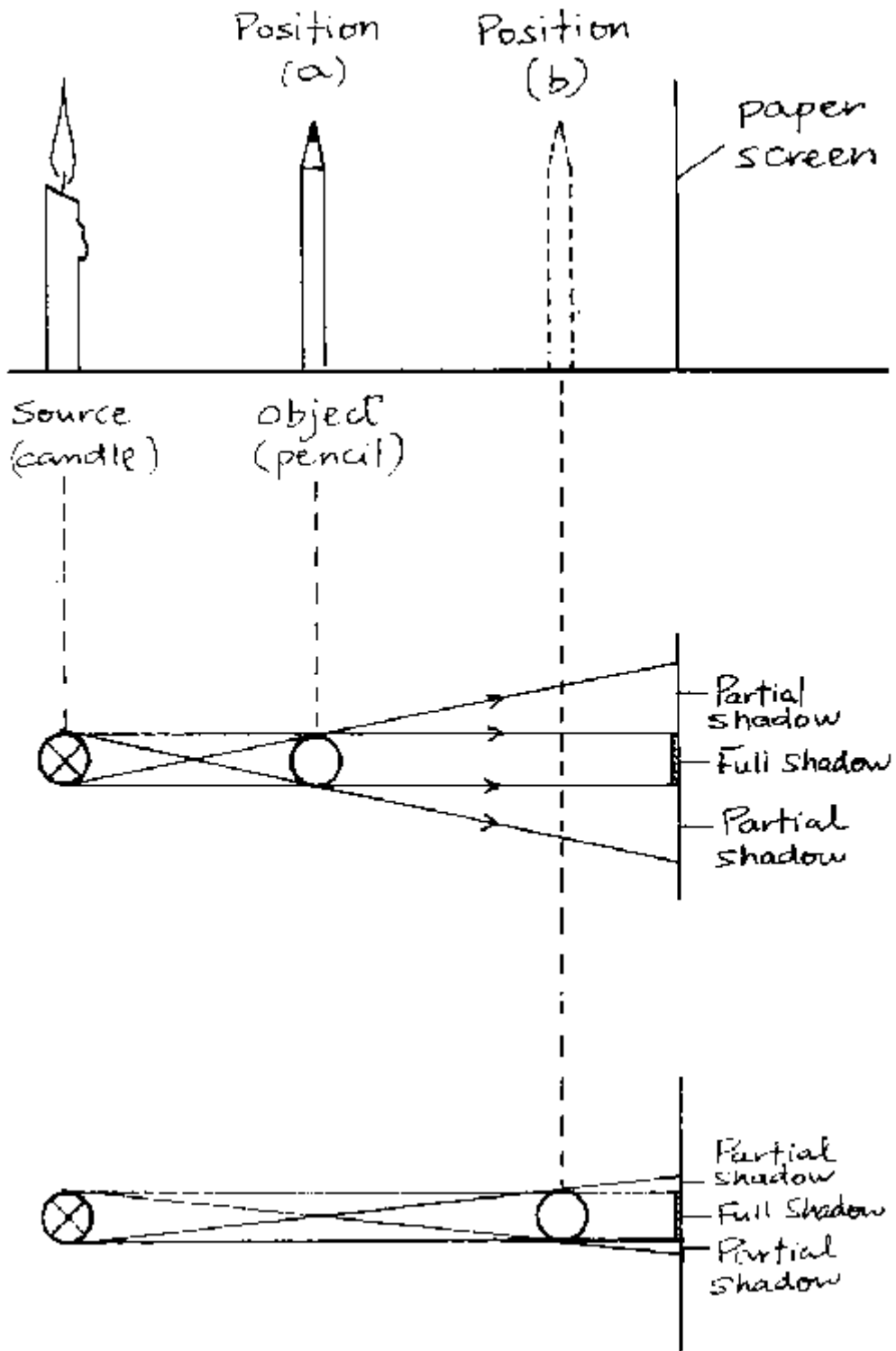

**P:** Hold a pencil between a source of light (e.g. candle) and a white paper. Observe the shadow formed on the paper (screen).

Gradually move the pencil closer to the screen and observe the change in the shadow.

**Q:** How does the shadow change?

Explain this with the use of ray diagrams.

**E:** The shadow becomes sharper as the obstacle (pencil) approaches the screen.

The figures show that *full shade* exists only on those points of the screen, which are *not hit at all* by rays coming from any light source. Wherever points of the screen receive rays from a *part* of the light source only (but *not* from the whole source), there is *partial shade*.

### 7.1.5 Shadows Using two Light Sources

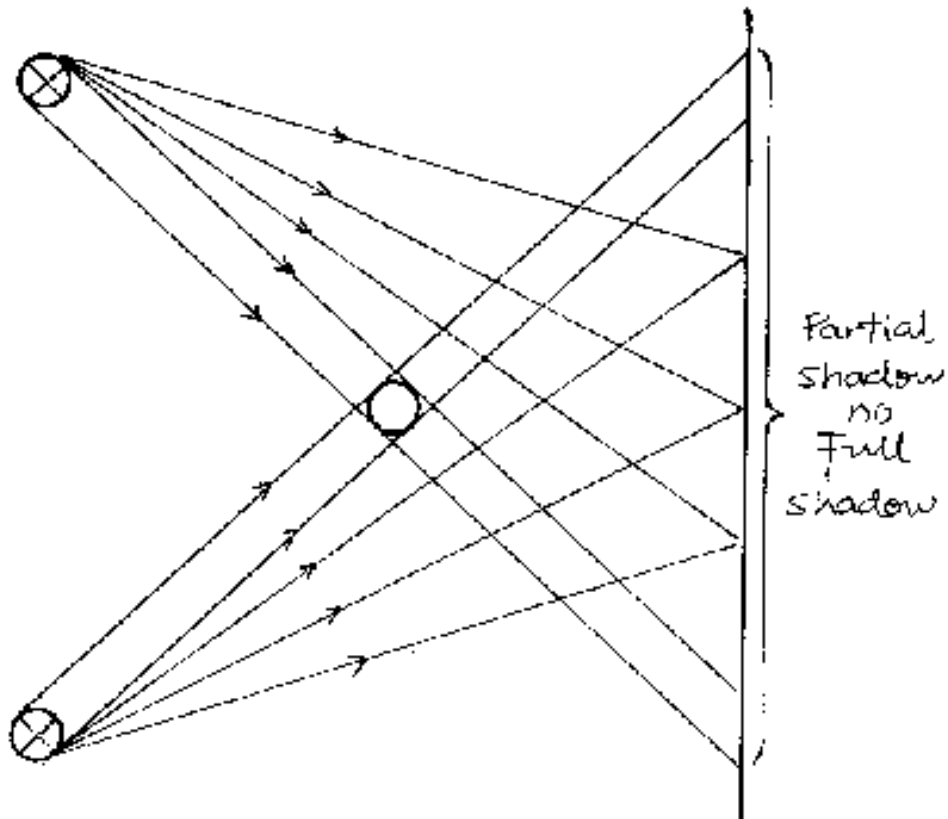

**P:** Repeat the above experiment using two candles and one pencil. Observe the shadows formed.

**Q:** Explain the results and discuss the formation of shadows by a point source and extended source of light.

**E:** The figure shows that all the points of the screen which do *not* receive rays from candle 1, *do receive* rays from candle 2 and vice versa. Thus, full shade does not exist in this experiment (except the object is brought very close to the screen).

### 7.1.6 Rays in the Smoke Box

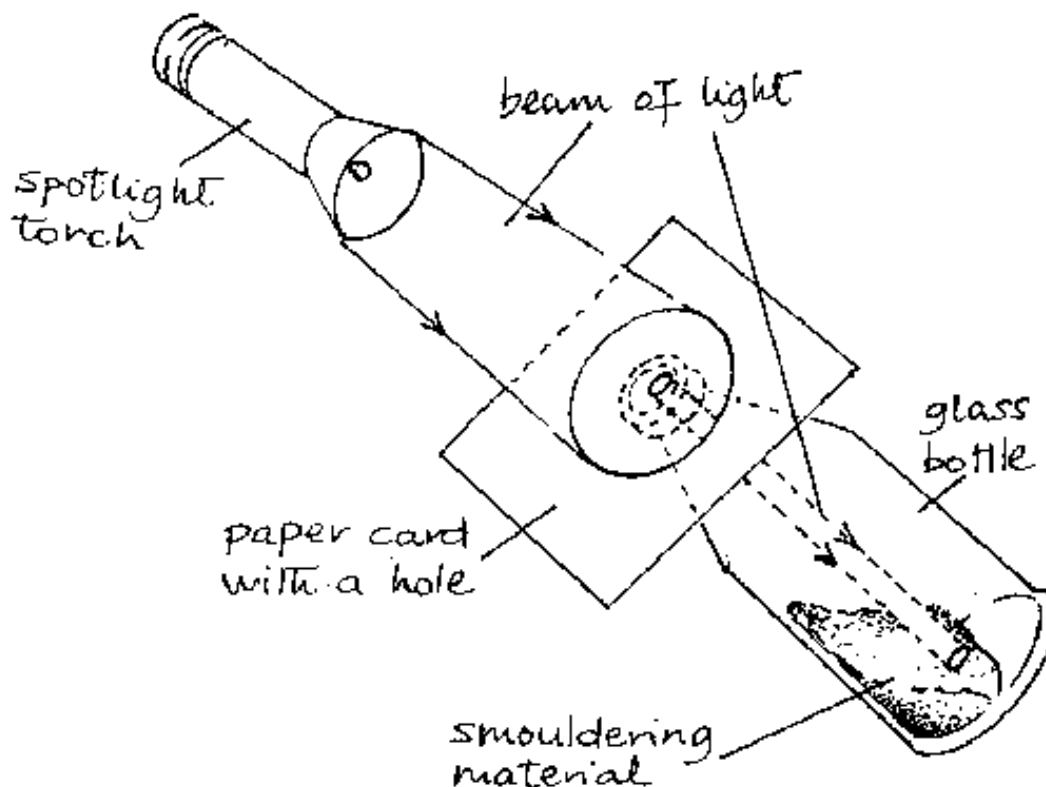

**P:** Make a smoke box using a glass bottle and some smouldering material e.g. damp paper, cotton wool etc., as shown in the figure.

Produce parallel and divergent beams of light by using small and larger holes in the papercard covering the mouth of the bottle. In a dusty room, parallel, convergent and divergent beams of light can be visible when the floor is swept.

Sunlight or torchlight may be used as a source of light.

**Q:** How is it possible for smoke or dust to make beams of light visible? Why are sunlight rays parallel?

**E:** The smoke particles reflect some of the light in all directions and hence make it visible.

Sunlight rays are parallel when they reach the earth, because the earth is 150 million km away from the sun.

### 7.1.7 Beams of Light

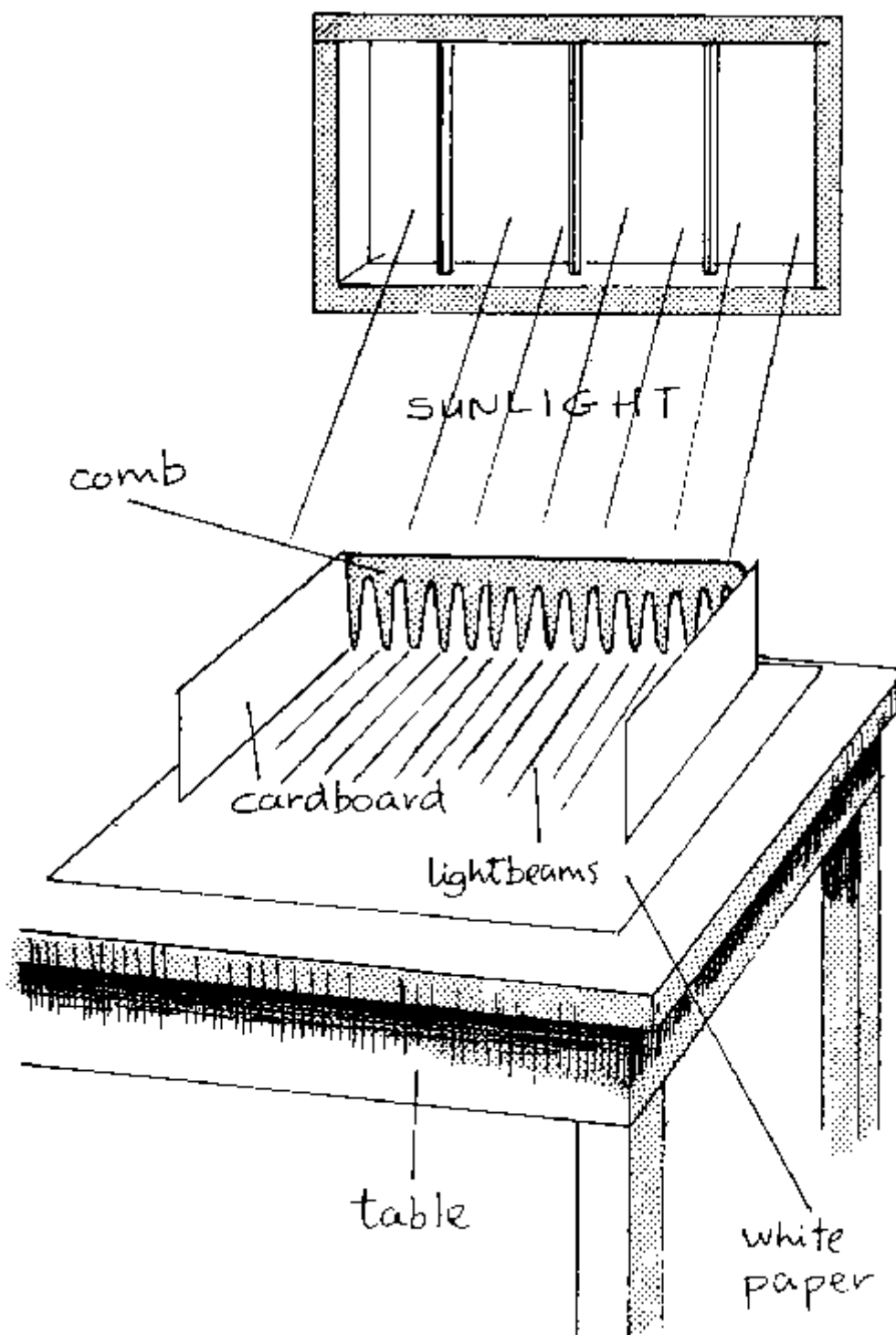

**P:** Hold a comb on a white paper placed on a table. Place pieces of cardboards by the sides of the comb (see diagram).

**Q:** What do you observe on this white paper? Explain.

Trace the beams of light which become visible on the white paper. Explain what is meant by the words "rays" and beam of light.

**E:** A *ray* is the direction of the path taken by light. A collection of rays forms a *beam*.



Since the sunlight consists of parallel rays, *parallel* beams of light will be observed on the white paper.

### 7.1.8 Shadow Formation by Point and Extended Sources of Light

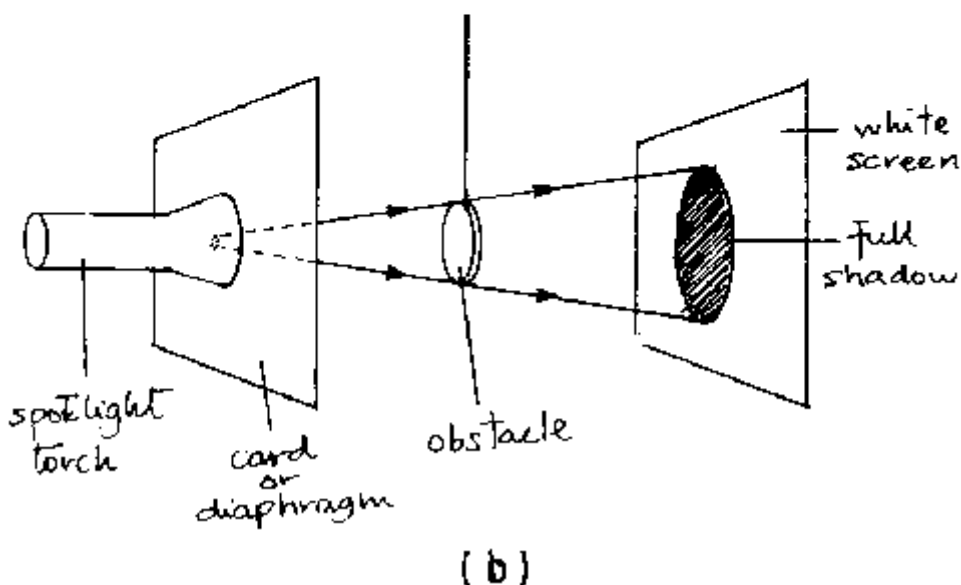
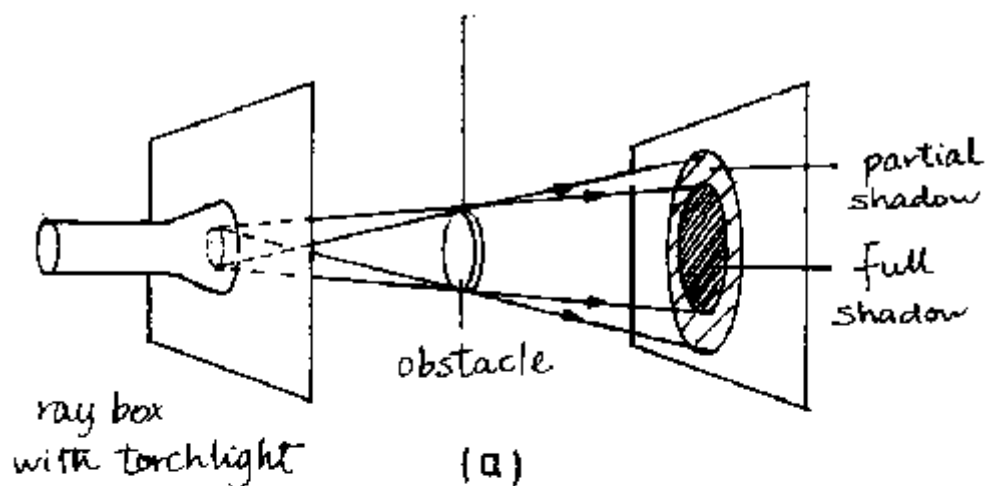

**P:** Place a torch light behind a cardboard with a hole in it. The assembly is called a *ray box*. Observe the shadow formed by an obstacle placed in the light from a ray box with a large hole (see fig. a).

Change the hole of the ray box to a very small size and note the shadow formed by the same obstacle on the same screen (see fig. b).

Repeat the above experiments with sunlight.

**Q:** In which case do you get

- (i) full and partial shadow?
- (ii) full shadow only?
- (iii) Sharper shadows?

Explain why the shadows formed by sunlight are not typical of your results in these experiments.

What do these experiments suggest about the way light travels?

**E:** All the experiments give evidence that light travels in straight lines.

Single *extended light sources* give partial and full shadows.

Single *point sources* give mainly full shadows. Sharper shadows are obtained when an obstacle intercepts parallel rays, i.e. rays from a distant source. Though the sun is an extended source, its rays reach the earth parallel and therefore produce sharp shadows.

## 7.2 Reflection of Light

When light strikes a surface separating two different media, part of it is thrown back to the original medium. This phenomenon is called *reflection*.

If the surface is smooth, reflection is regular, otherwise it is diffuse. The position of the object determines the position and attribute of the image.

The *law of reflection* states:

The *angle of incidence is always equal to the angle of reflection*. These angles are always measured *against the normal* of the reflecting surface.

This is sufficient to construct *ray diagrams* for plane mirrors. For *spherical mirrors* the following rules are helpful for the construction of ray diagrams:

- (i) *Rays parallel to the axis are always reflected through the principal focus F.*
- (ii) *Rays passing through C (the centre of curvature of the mirror) are reflected back along their own path.*
- (iii) *Rays passing through the principal focus F are reflected parallel.* (Reverse light path of (i).)

The distance of F from the mirror surface is called the *focal length f*. For spherical mirrors the *radius of curvature r* is always equal to  $2f$ :  $r = 2f$ .

### 7.2.1 The Kaleidoscope (Inclined Mirrors)

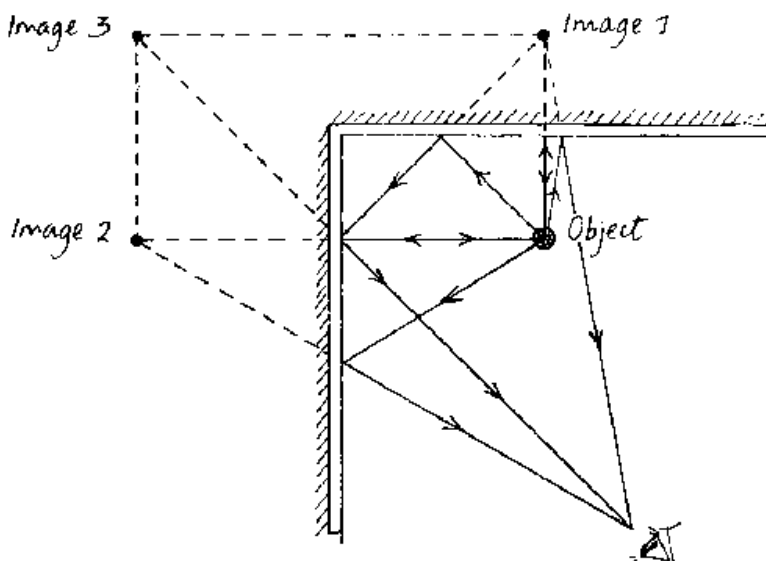

**P:** Arrange two plane mirrors to meet each other at right angles as shown. Confirm that three images of one object (candle) can be seen simultaneously. Refer to figure.

Repeat the experiment with mirrors at angles of  $60^\circ$  and  $30^\circ$  to each other.

**Q:** How many images can be seen in each case?

**O:** When mirrors are at  $60^\circ$  to each other, five images are seen, at  $30^\circ$  eleven images are observed. When the mirrors are parallel to each other, there is a large number of images.

**H:** Note that the number of images =  $(360^\circ \div \text{angle between the mirrors}) - 1$

**A:** The kaleidoscope arrangement is used in shops and pavillions to display items.

### 7.2.2 The Focus of a Concave Spherical Mirror

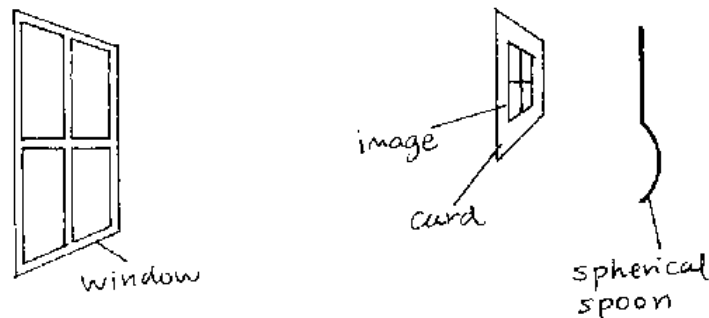

**P:** A simple concave mirror is the face of a shiny spherical spoon. Hold the curved mirror and a white card in front of the mirror as shown in the figure. Point it towards a distant window, so that it throws the image of the window on the white card. Move the mirror back and forth to find a position where it gives you a clear image on the white card. Note the image distance (the distance from the mirror to the card).

**Q:** Draw a ray diagram for this experiment. How are the rays coming from the distant window? What does the image distance give in this case?

**E:** Since the window is distant, its rays meet the mirror parallel. Hence, they are reflected through F. Thus, the image distance recorded give  $f$ , the focal length of the mirror.

### 7.2.3 The Radius of Curvature of a Concave Spherical Mirror

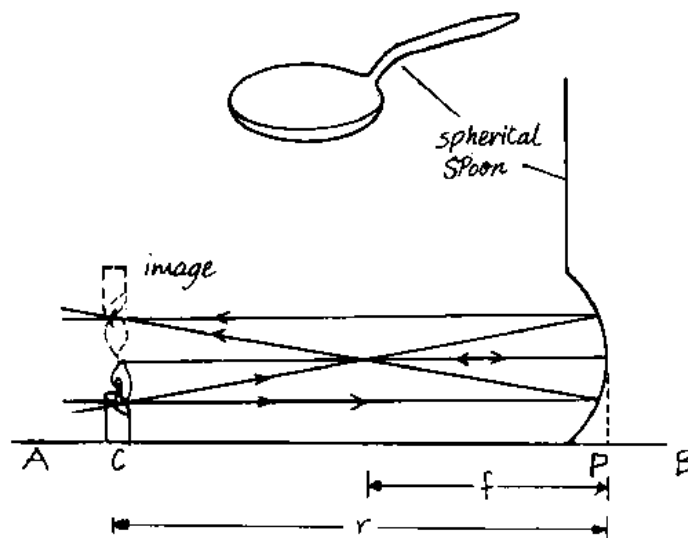

**P:** Draw a line AB on a white sheet of paper. Place a concave mirror on the paper with its centre vertical above point P. Light a candle and place it in front of the mirror on line AB, see in the figure.

Move the candle back and forth along line AB to get a point C on AB, where the inverted image of the candle coincides with the object candle. Point C is a *point of no parallax* because when you move your head slightly to the left or right, the object and image remain inseparable.

**Q:** Measure the radius of curvature  $CP = r$ . Compare your values of  $f$  and  $r$ . What do you find out?

Draw ray diagrams to show how the mirror forms images of an object placed at different positions. How would the mirror work best as a shaving mirror?

**E:** The ray diagram shows that C is the centre of curvature and hence  $r = 2f$ .

Ray diagrams show that (i) the *concave mirror* produces a real, inverse and magnified image, if the object is farther away than F from the mirror.

(ii) If the object is nearer to the mirror than F, the image appears to be behind the mirror and is hence virtual. However, it is erect and magnified. In the latter case the mirror works best as a shaving mirror.

**A:** Shaving mirror, dentist's mirror, floodlight (case (ii)); if the object (bulb) distance =  $f$ : torch, car headlight.

#### 7.2.4 Convex Spherical Mirror

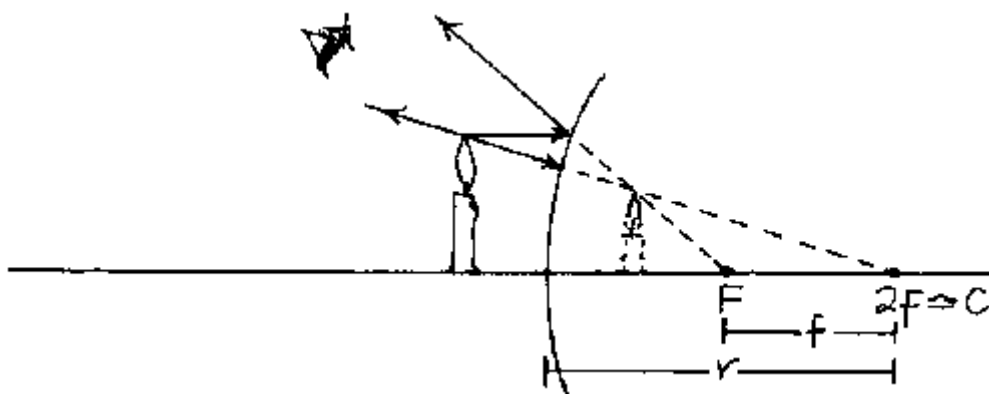

Arrange the back of a spherical spoon (a convex spherical mirror) and a lighted candle on a white sheet of paper. Locate the image formed by use of a needle or a lighted candle held behind the mirror. The image position is the point of no parallax (see 7.2.3) between the image and the locating needle or candle.

Mark the position of the object, the mirror and the image. Measure the object size, the object distance and the image distance.

Draw the ray diagram to show how the convex mirror forms an image (see the figure).

**E:** The image seen is always virtual, erect and reduced in size.

**A:** The convex spherical mirror is used as a rearview mirror in cars because it gives a broad field of view.

### 7.2.5 Candle in Water Experiment

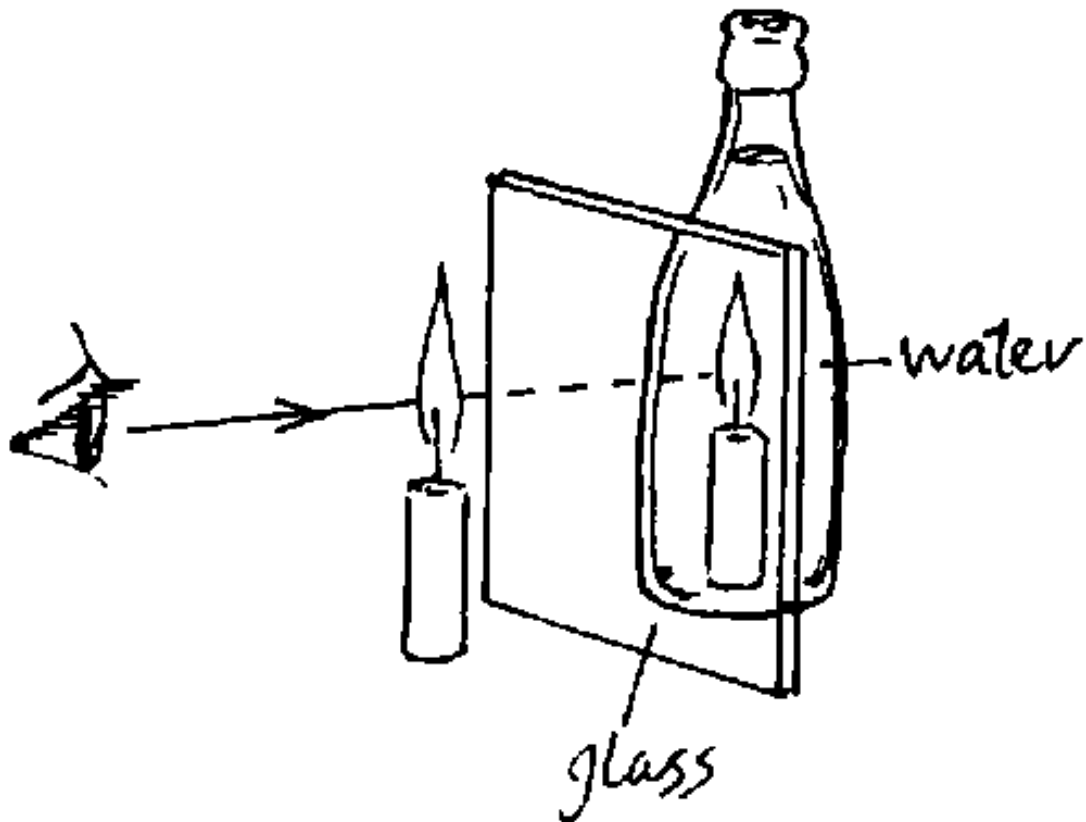

**P:** Place a transparent glass-pane mid-way between a lighted candle and bottle full of water. View the bottle through the glass-pane from the side of the candle.

**Q:** At what position do you see the image of the burning candle?

**O:** The candle appears to burn in the water in the bottle.

Explain this observation using a ray diagrams.

### 7.2.6 The Periscope

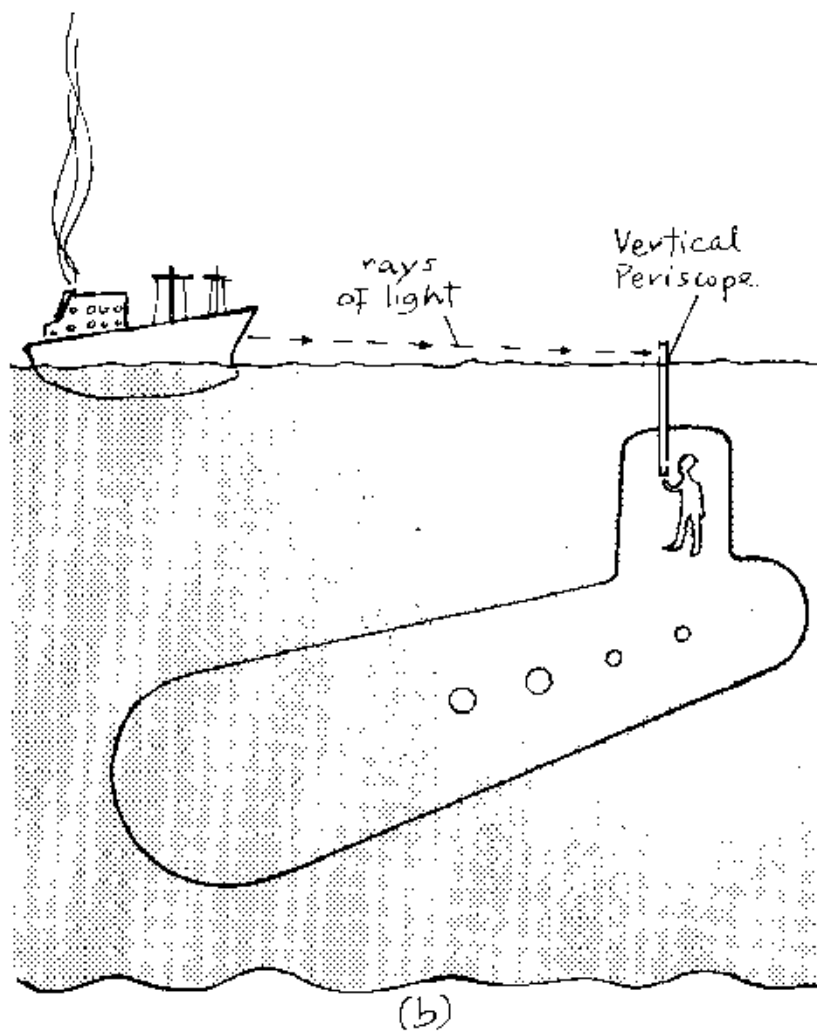
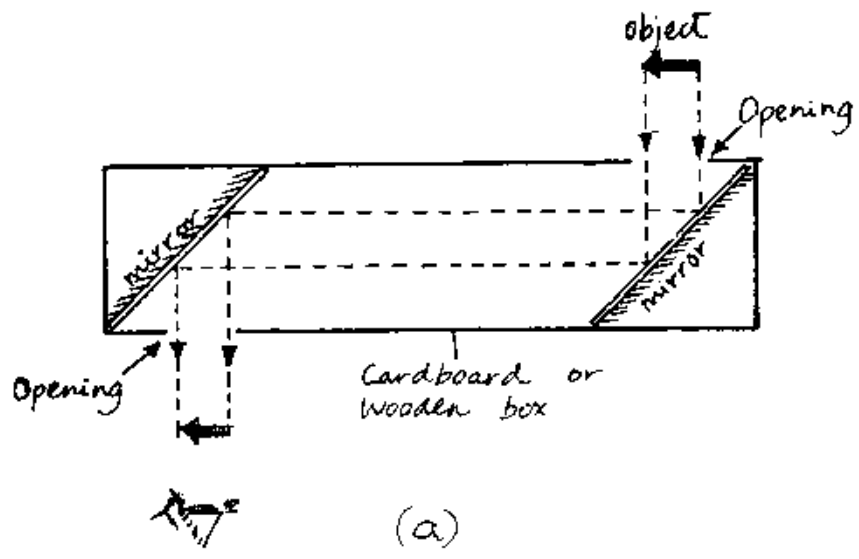

**P:** Arrange two mirrors in a rectangular box as shown in figure (a). This instrument is called a *periscope* and allows to observe objects behind corners.

**Q:** Observe objects placed behind obstacles.

How do they appear?

Write the word OPTICS on a paper and use it as an object. How does the image appear?

Compare your observations with experiment 7.2.7.

**A:** The periscope is used in dived submarines to see what is above the water surface, see figure (b).

### 7.2.7 Reversed Image

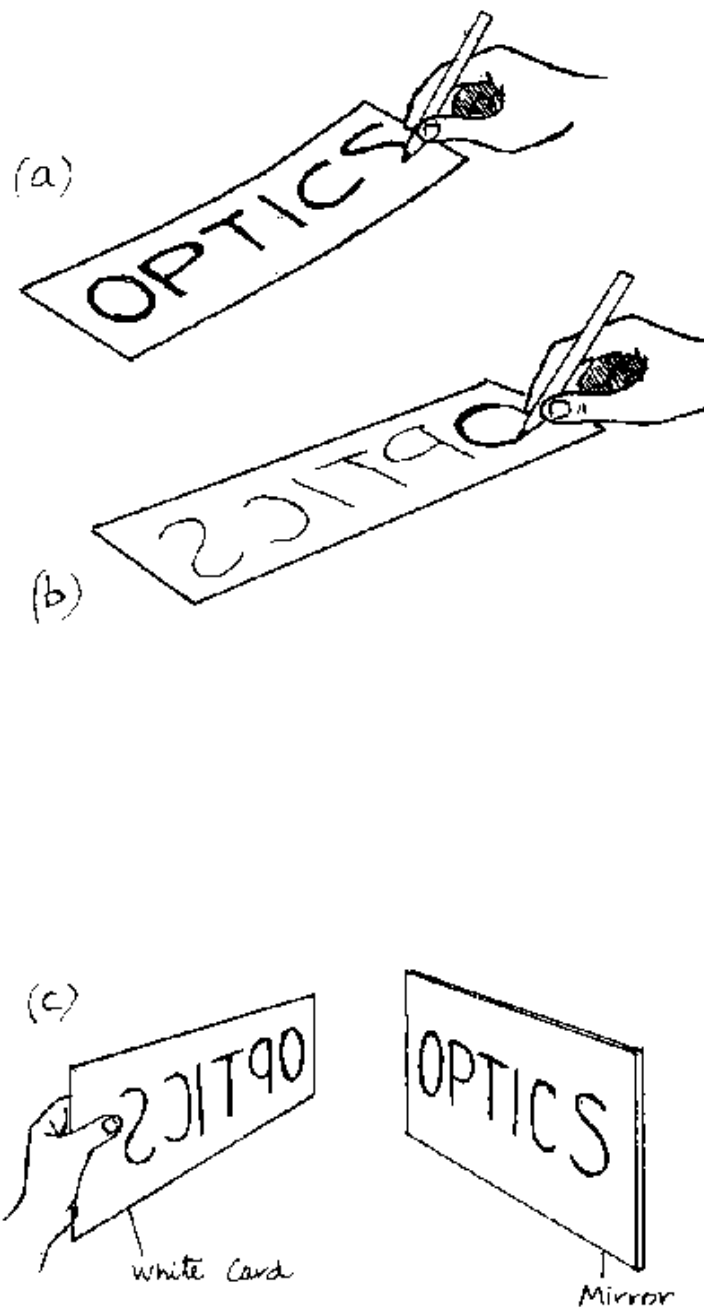

**P:** Write the word OPTICS on an ordinary piece of paper, see figure (a). Turn the piece of paper and retrace the faint word appearing on its back, see figure (b). You will obtain the *mirror-writing* of the word OPTICS. The latter is a reversed image of the former.

Place the piece of paper in front of a plane mirror (see figure (c)).

**Q:** What do you see? Repeat using the word at the back side of the paper. What do you see? Compare your observations with those under section 7.2.6. What do you conclude about the mirror image?

**E:** Mirror images are reversed images, i.e. the left and right side of the object are interchanged.

### 7.3 Refraction of Light

*Refraction* is the change in direction of light as it passes from one medium into another of different density. Refraction is used in lenses to produce images in cameras, microscopes, telescopes, etc. *Total internal reflection* takes place on the boundary between an optically denser medium (e.g. glass) and an optically less dense medium (e.g. air), when the angle of incidence in the denser medium is greater than the *critical angle*.

#### 7.3.1 The Rising Coin

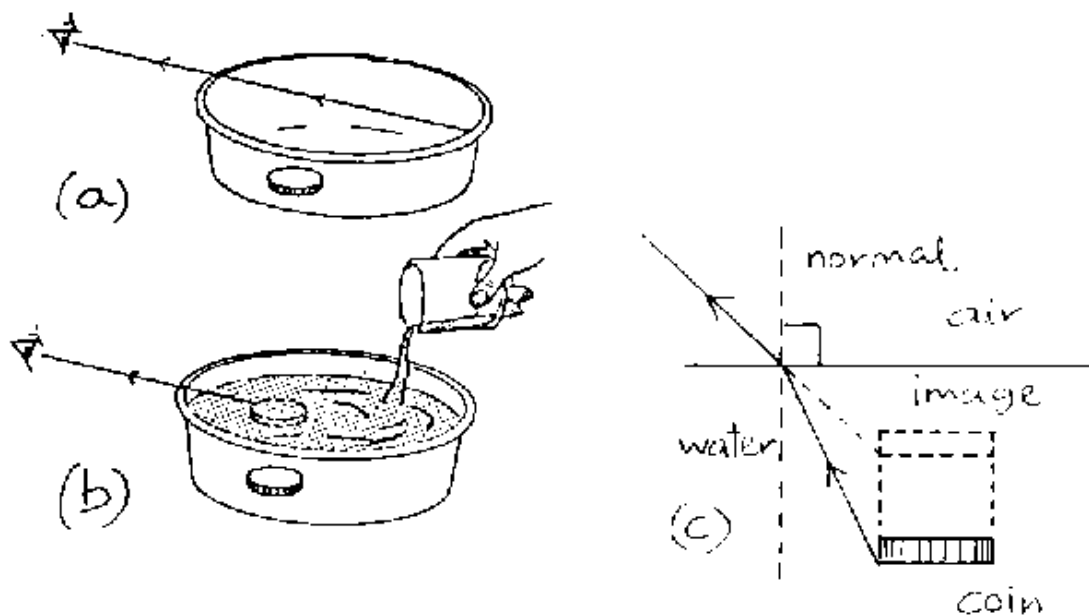

**P:** Put a coin in the lid of a jam jar.

Hold the lid up to almost level of your eye, until you just cannot see the coin in the bottom of the lid. Gently pour water in the lid to cover the coin completely. The coin will be visible to you again, see figures (a) and (b).

**Q:** Explain your observation with the use of a ray diagram.

**E:** The ray diagram of figure (c) shows that we can only see the coin because the light rays coming from it are deflected at the water surface away from the normal of the water surface.

**P:** Lower the lid and look at the water vertically from above



**Q:** Where does the coin appear now?

Explain the observation.

**O:** When viewed vertically from above the coin appears to be at the bottom of the lid. However, the bottom seems to have risen because of the refraction of those rays which reach the water surface under an angle of incidence different from  $0^\circ$ .

**P:** View the coin from different directions.

**Q:** How does its position seem to change?

**E:** When viewed at an angle from the vertical the coin appears to be raised above the bottom of the lid, therefore as the viewer changes position the coin's position also seems to change because of the refraction.

### 7.3.2 Total Internal Reflection

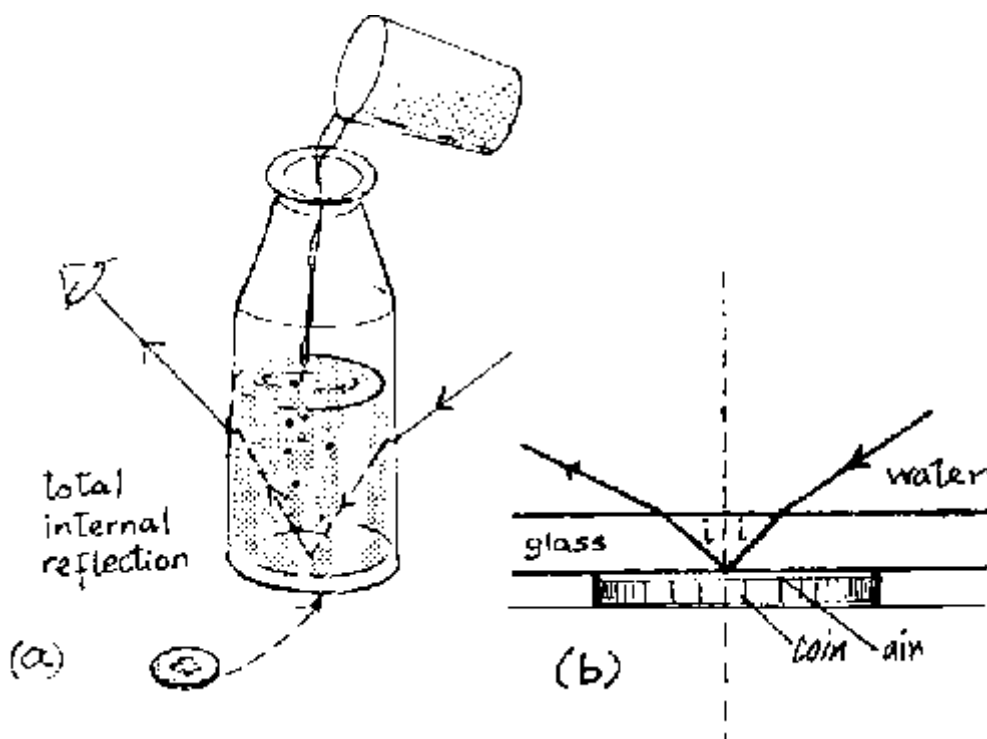

Place a transparent bottle on a coin and look at the coin from above at an angle from the normal. The coin can be seen. Pour water into the bottle slowly. There is a level at which, when you look at the coin, it disappears from sight, see figure (a).

This phenomenon is called *total internal reflection*. It is a special type of refraction. In our experiment, it takes place at the bottom of the bottle where the glass borders the air (above the coin). Total reflection only takes place on a boundary between an optically denser (e.g. glass) and an optically less dense medium (e.g. air) when the angle of incidence in the denser medium is greater than the *critical angle*. In our case the light rays coming from the right side into the glass of the bottom of the bottle are totally reflected and then coming to your eye, see figure (b). These rays are *not* refracted to the air outside the bottom of the bottle because their angle of incidence  $i$  is larger than the critical angle for a glass/air boundary which is  $42^\circ$ . These totally reflected rays are so strong that they completely cover the relatively weak rays coming from the coin. Hence, the coin cannot be seen any longer.

**A:** Prisms in binoculars, etc., see 7.3.6.

### 7.3.3 Bending a Pencil with Water

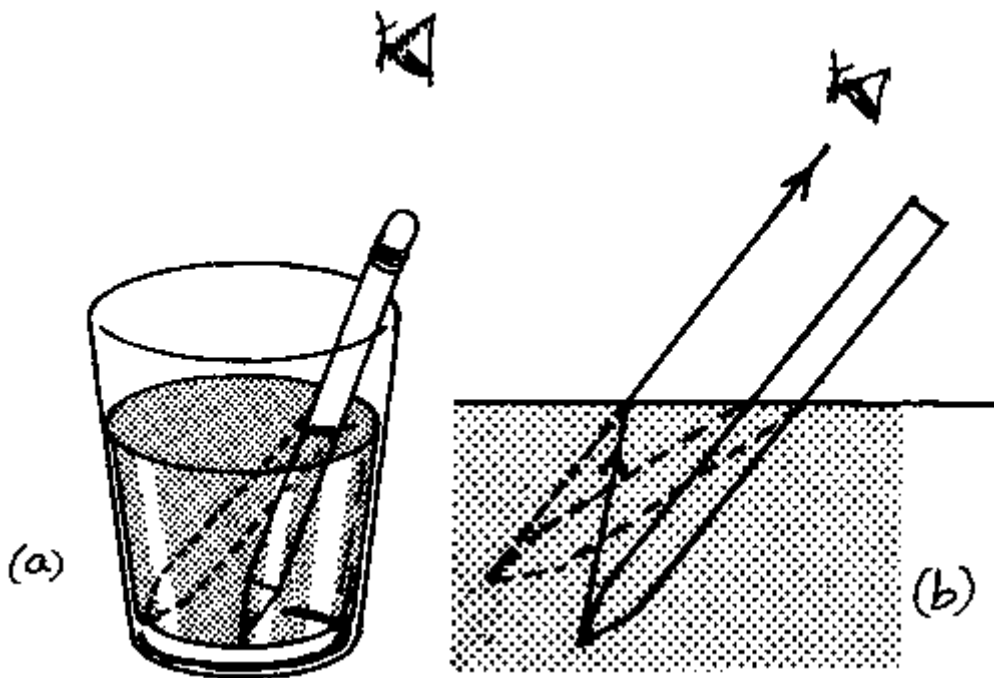

**P:** Pour water in a glass. Place a pencil in the water at a slant position, see figure (a). Look at the pencil through the surface of the water sidewise along its length and note what you see. Explain your observation by using a ray diagram.

**E:** Figure (b) gives the ray diagram which explains the observation that the pencil seems to be bent by refraction.

### 7.3.4 The False Pin

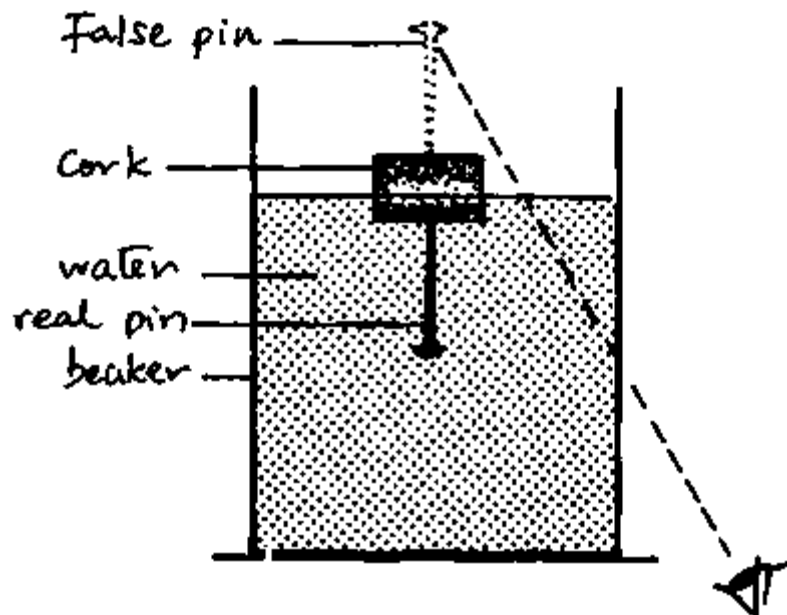

**P:** Stick a pin (office pin) into the underside of a small cork and allow it to float in a beaker full of water.

Hold the beaker above your head and look up through the side of the beaker at an angle from the vertical.

**Q:** What do you see?

**O:** You will see the real pin below the cork and a fake pin above the cork.

### 7.3.5 Explaining the False Pin

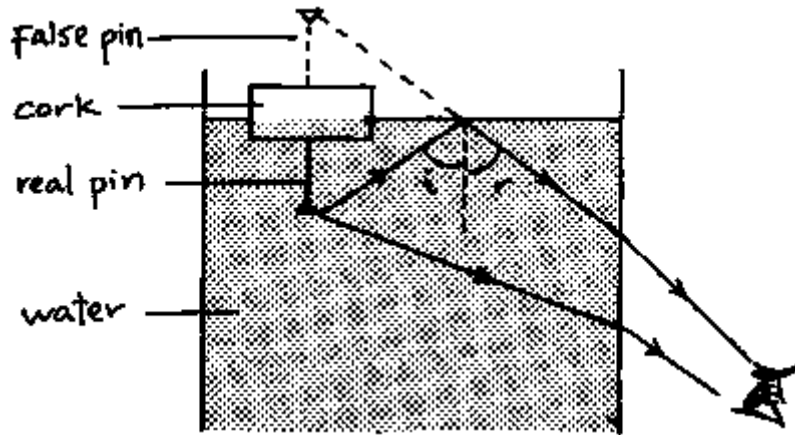

Draw a ray diagram and explain how the false pin appears on top of the cork.

**E:** Some rays from the pin towards the eye are refracted at the glass-air boundary making the pin visible to the eye.

Other rays from the pin undergo total internal reflection at the water-air boundary. The reflected rays are refracted at the glass-air boundary before they reach the eye. Hence the eye sees a virtual image of the pin on top of the cork as shown in the figure.

Hence both the real pin and the false pin can be seen by the observer.

### 7.3.6 Total Internal Reflection in Prisms

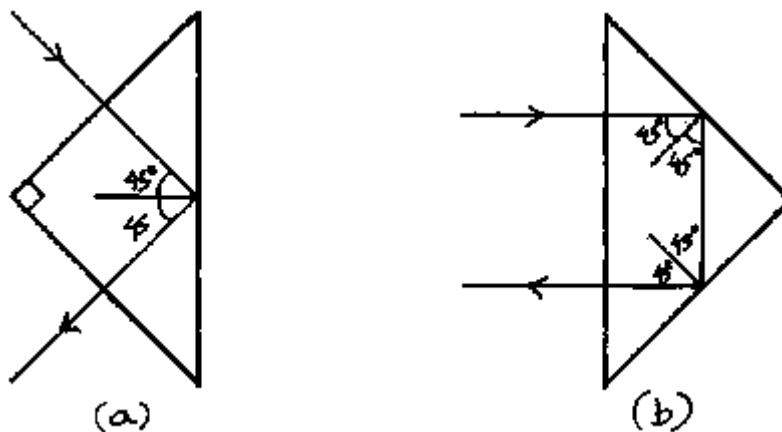

**P:** Total internal reflection occurs when light falls on a glass prism with angles of  $45^\circ$ ,  $45^\circ$  and  $90^\circ$ . This is because a ray falling normally on any face of such a prism hits the inside face at  $45^\circ$ , and this is greater than the critical angle of glass/air (about  $42^\circ$ ). In figure (a) the ray is turned through  $90^\circ$  and in figure (b) through  $180^\circ$ .

**A:** Totally reflecting prisms are used in periscopes (instead of mirrors) and in binoculars.

## 7.4 Lenses and Optical Instruments

Any transparent material bounded by at least one curved surface acts as a lens. Common examples of lenses are made of glass. By their action on rays of light lenses can be put into two groups: the converging and the diverging lenses. A *converging (convex) lens* is thickest at its centre whereas this is where the *diverging (concave) lens* is thinnest. The action of a lens is due to the refraction of the rays on its curved boundaries. For the construction of *ray diagrams* for *thin* lenses the following rules are helpful:

*For both types of lenses: rays passing through the centre of the lens travel straight on, see figure (a).*

*For convex (converging) lenses: rays parallel to the axis are refracted through the principal focus F, see figure (b).*

*For concave (diverging) lenses: rays parallel to the axis are refracted away from the nearer principal focus F, see figure (c).*

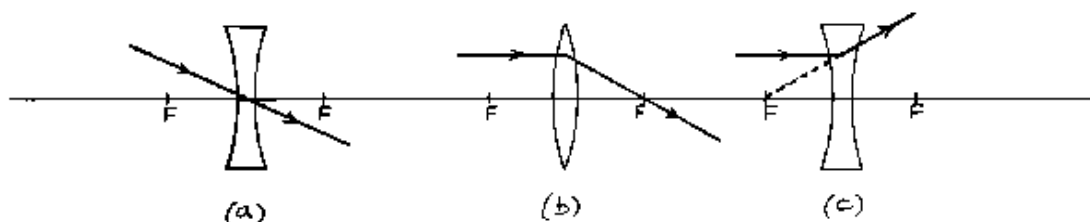

### 7.4.1 Action of a Convex Lens on Parallel Rays

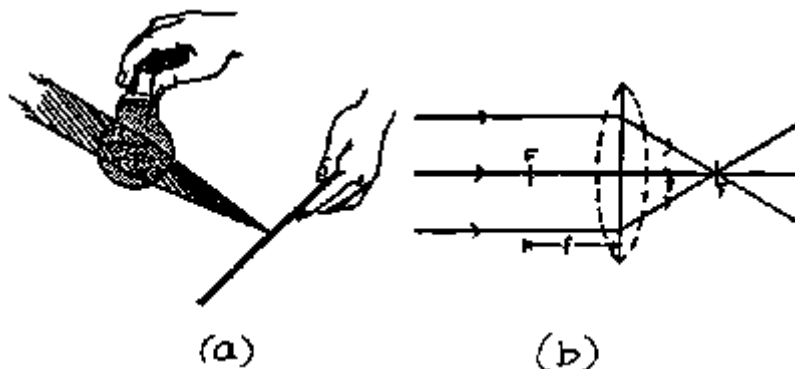

**P:** Hold a water filled opened bulb (see appendix) or a concave lens into the direct sunlight and focus the light on one spot of a paper.

**E:** The distance between the centre of the bulb or lens and that spot on the paper is called the *focal length*  $f$ . We can draw a ray diagram for this experiment, see figure (b). The focal points are denoted as F. The action of the lens or bulb on the rays is explained by refraction of the rays on its curved surfaces.

**H:** The bulb is *not* a *thin* lens. Hence the focus is not as sharp as with a thin lens.

### 7.4.2 Action of a Concave Lens on Parallel Rays

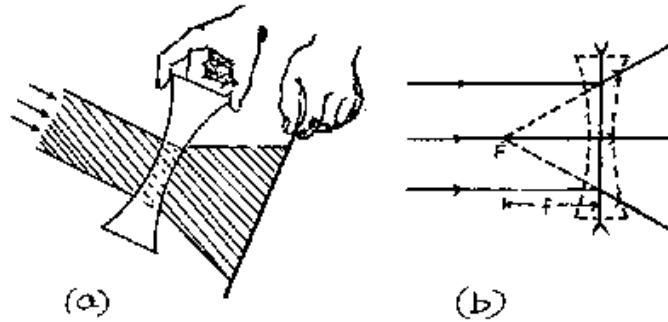

**P:** Try to repeat experiment 7.4.1 using a concave lens. If that is not available, the base of a soda bottle or a thin film of water on a wire loop also can serve as a concave lens.

**Q:** What do you observe? Do you find a focal point?

**O:** No focal point can be found.

**E:** This lens *diverges* the light and hence no real focus exists.

However, the ray diagram (see fig. b) shows that a *virtual* focal point can be found on the same side of the lens on which the light source is.

### 7.4.3 How to Construct a Simple Box Camera

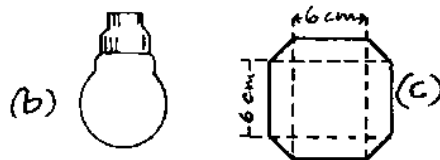
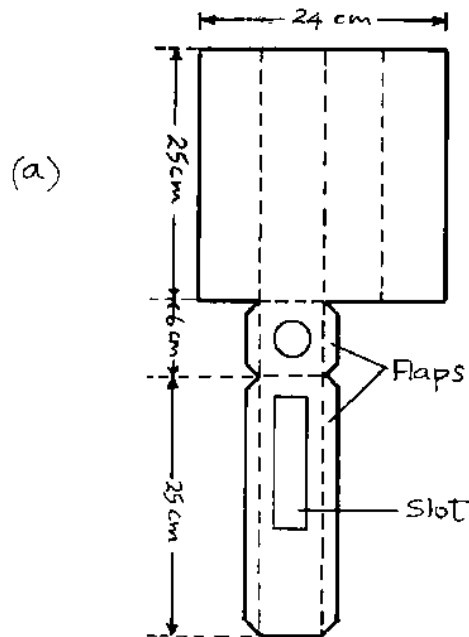

- P:** (i) Cut a piece of manila sheet according to the plan of a rectangular box in figure (a).
- (ii) Open the bulb seal of a transparent used up electric bulb and remove the filament. Then fill it with water to make the water lens (see appendix).
- (iii) Fold the manila sheet cutting (figure (a)) along the dotted lines. Fit the water lens on the slot and close the box by gluing the flaps.
- (iv) Cover the open end with a piece of plain paper or (better) parchment paper as a screen using glue (see figure c).
- (v) Close the slot using a sliding manila sheet cover, having dimensions of 6 cm by 30 cm with a hole to fit the bulb at its centre.

**H:** Make sure that the box is light-tight (light-proof).

#### 7.4.4 Using the Simple Box Camera

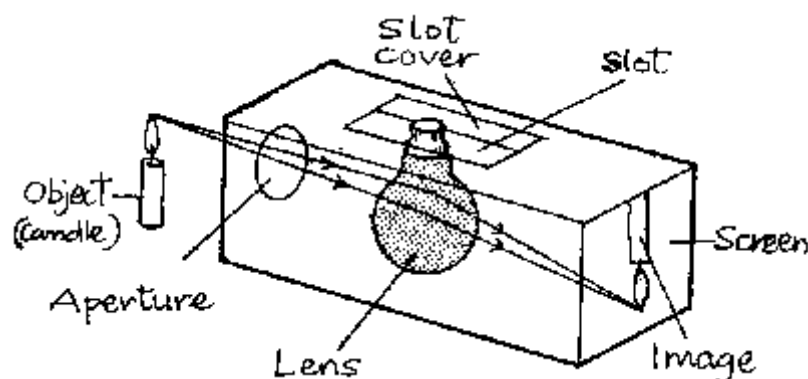

**P:** Use the simple box camera to produce images of illuminated objects like a candle, a window etc. Change the position of the lens (bulb) so that you obtain a sharp image on the screen.

- (i) Find the focal length  $f$  of the lens (bulb) by focussing a distant object (e.g. a distant window) on the screen. Then the image distance  $v$  is equal to  $f$ . Measure the image distance  $v$  on top of the camera from the centre of the bulbs neck to the screen.
- (ii) Choose a large object distance  $u$  of a lit candle (the distance between the centre of the lense (bulb neck) and the candle) and adjust the lens so that you obtain a sharp image on the screen.
- (iii) Now decrease the object distance by moving the camera towards the object and adjust the image distance each time.
- (iv) Note  $u$  and  $v$  at which the image size becomes larger than the object size.

**Q:** Why is  $v = f$  in case (i)? How is the image distance  $v$  in each case? How is the size of the image (e.g. of the candle flame) as compared with the size of the object in each case? What kind of image do you obtain?

**E:** (i)  $v = f$  because the rays coming from a distant object are parallel.

(ii), (iii) The size of the image grows larger as the object distance  $u$  decreases. First the image size is smaller than the object size. When  $u = 2f$ , then the image size is equal to the object size. All images are *real* because they appear on a *screen*.

(iv) When  $2f > u > f$ , then the image size is larger than the object size. When  $u < f$ , no *real*

image can be observed.

**H:** The bulb is no thin lens hence the image will not be as sharp as with a thin lens which may be obtained from TAN OPTICS, P.O.B. 1929 Moshi, Tanzania.

**A:** (iii) Photographic cameras, (iv) projectors for movies and slides.

### 7.4.5 Ray Diagrams for the Box Camera

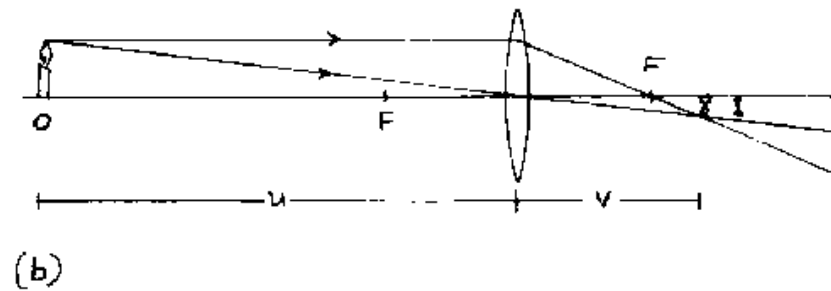
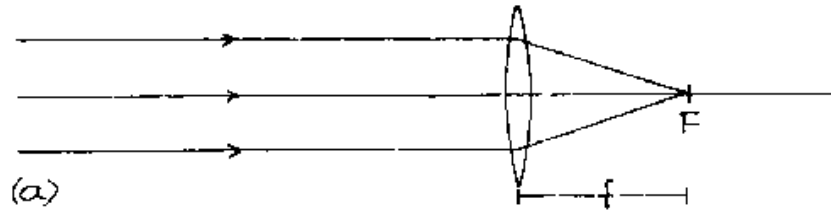

**P:** Ask the students to draw ray diagrams using thin converging (convex) lenses for the cases (i) to (iv) of experiment 7.4.4.

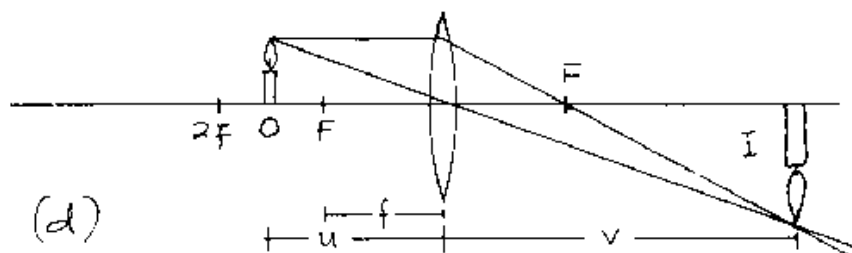
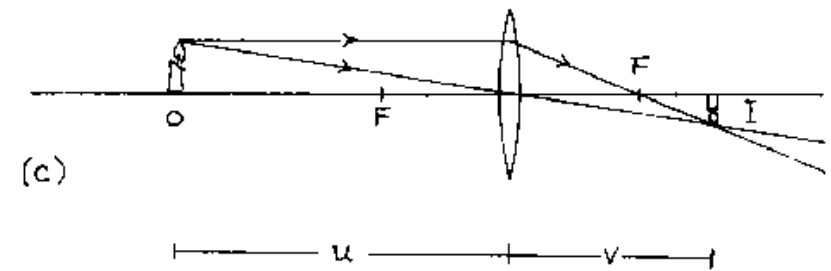

E: See figures (a) to (d) which correspond to the cases (i) to (iv) of experiment 7.4.4.

### 7.4.6 Magnification

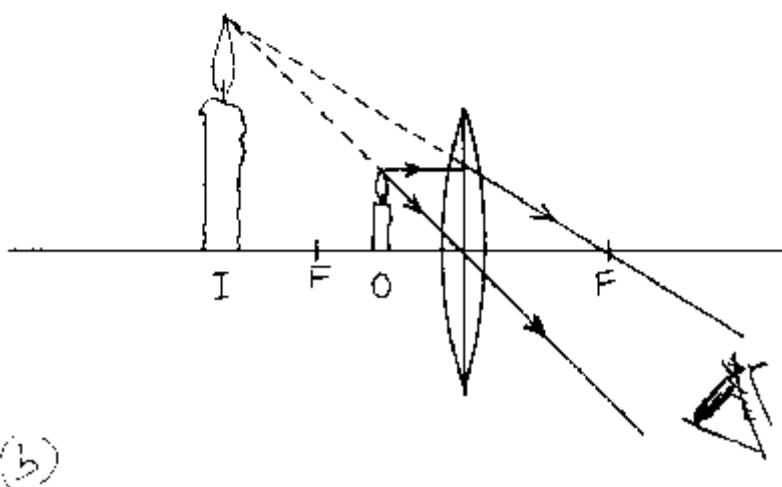
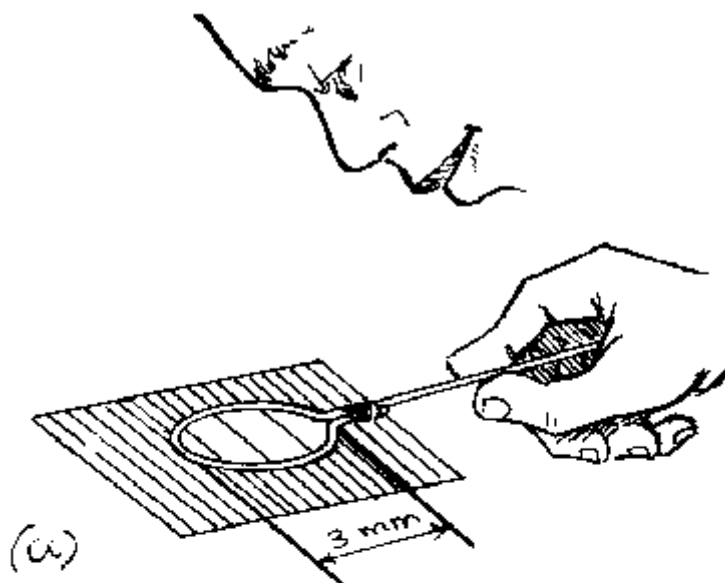

**P:** Produce a magnifying glass by making a loop as shown in figure (a) using paper clip wire (e.g. winding it around the tip of a ball point pen). Dip this loop in water and use it as a magnifying glass by observing letters in a book etc. Thus, this water drop lens acts as a convex lens.

**Q:** Explain the magnification by drawing a ray diagram. What kind of image is formed?

**E:** See fig. (b), the image is larger than the object. However, this image is *virtual* because it cannot be obtained on a screen. In a virtual image the light rays do not meet really in the image point. They only seem to meet there because the eye and brain of the observer are accustomed to assume that the light rays travel in straight lines only. Yet the real rays were refracted by the lens which causes the image to appear in the eye of the observer. The object distance  $u$  must be less than  $f$ :  $u < f$ .



**H:** A bulb filled with water can also be used.

**A:** Magnifying glass, eye lens of compound microscopes, telescopes etc.

### 7.4.7 Simple Microscope

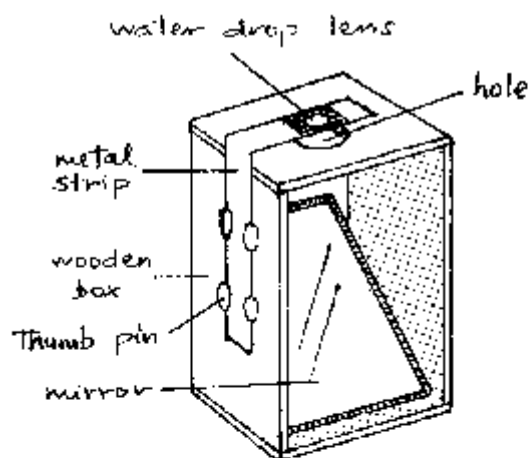

(a)

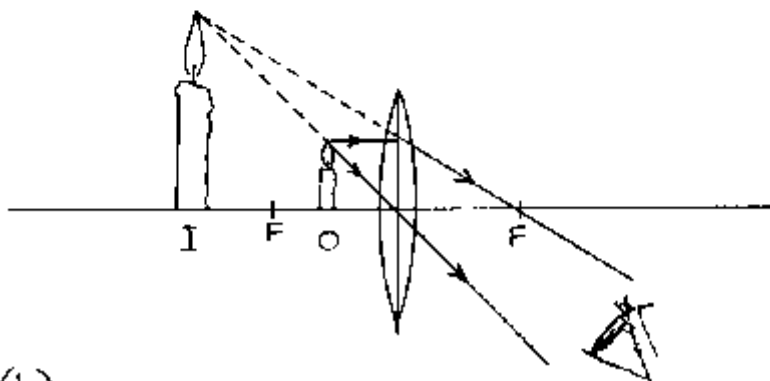

(b)

**P:** Produce a simple microscope according to the above figure. Adjust the mirror so that sun rays will be reflected to the hole below the lens. Place a transparent object (e.g. wing of a fly) on the hole and adjust the metal strip so that the water drop lens has less distance from the object than its focal length.

**Q:** How does the lens act here? What happens when you bring it even nearer to the object? Draw a ray diagram.

**E:** The lens acts here as a magnifying glass. When the object distance decreases further, the magnification will increase. The ray diagram is the same as in the last experiment.

### 7.4.8 Mirror Reflex Camera

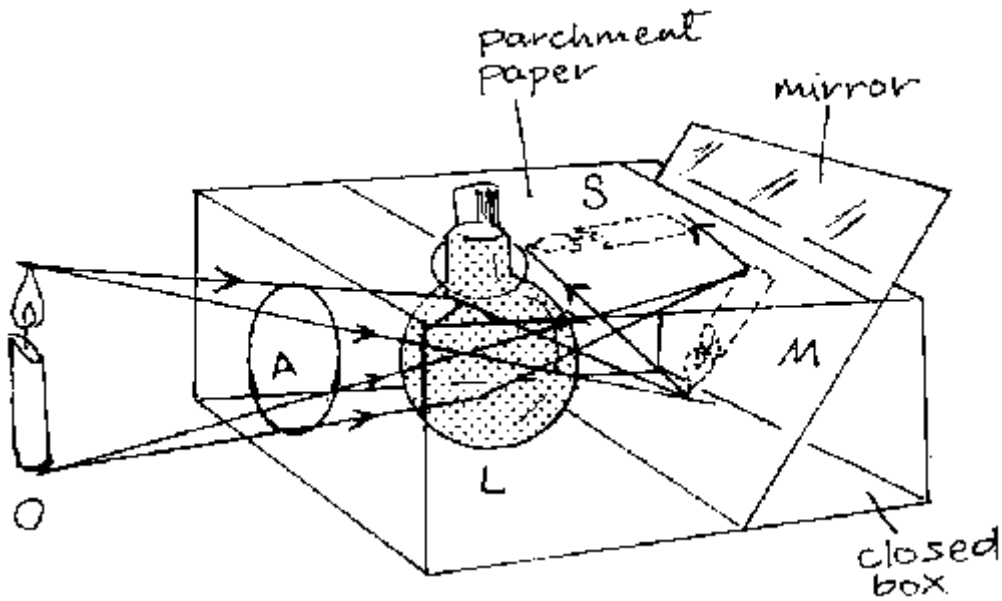

**P:** Modify the box camera (see p.90) according to the above figure using a mirror and another sheet of parchment paper to provide the top screen. Now this camera can serve as a model of a mirror reflex camera.

**Q:** Explain how a mirror reflex camera works.

**E:** In the mirror reflex camera the film is there where the screen is in the box camera (see p.90). The screen on top is just to view the same image (and to focus it) which will be produced on the film when the mirror has been removed. Thus, when taking a snap with the mirror reflex camera, the mirror is turned so that the image falls on the film instead on the top screen.

### 7.4.9 Display Chart of the Eye

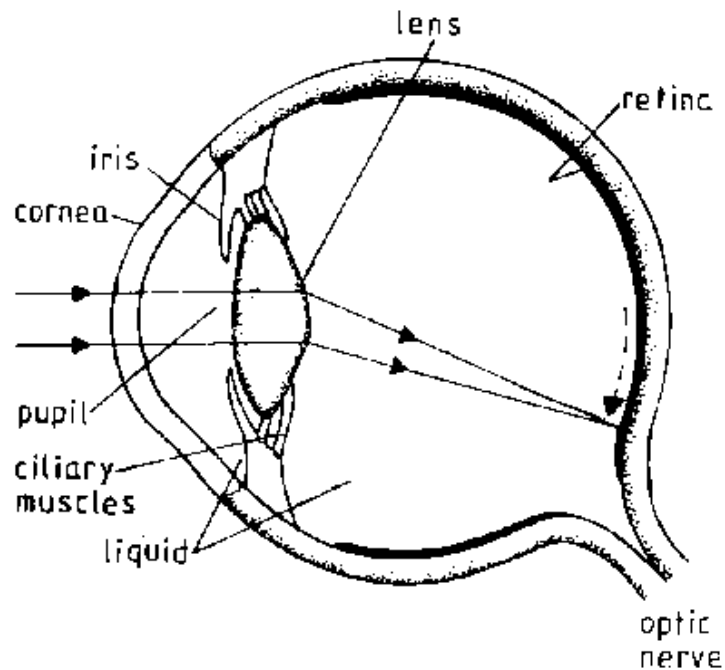

The eye possesses an convex lens which focusses the light on a sensitive membrane (called retina). In difference to the camera the eye lense changes its curvature and hence its focal length in order to focus the light from objects of different object distance. The focal length varies according to object distance while the image distance is kept constant and is roughly equal to the diameter of the eye, see the figure.

**P:** Draw a display chart of the above figure.

#### 7.4.10 The Long-Sighted Eye

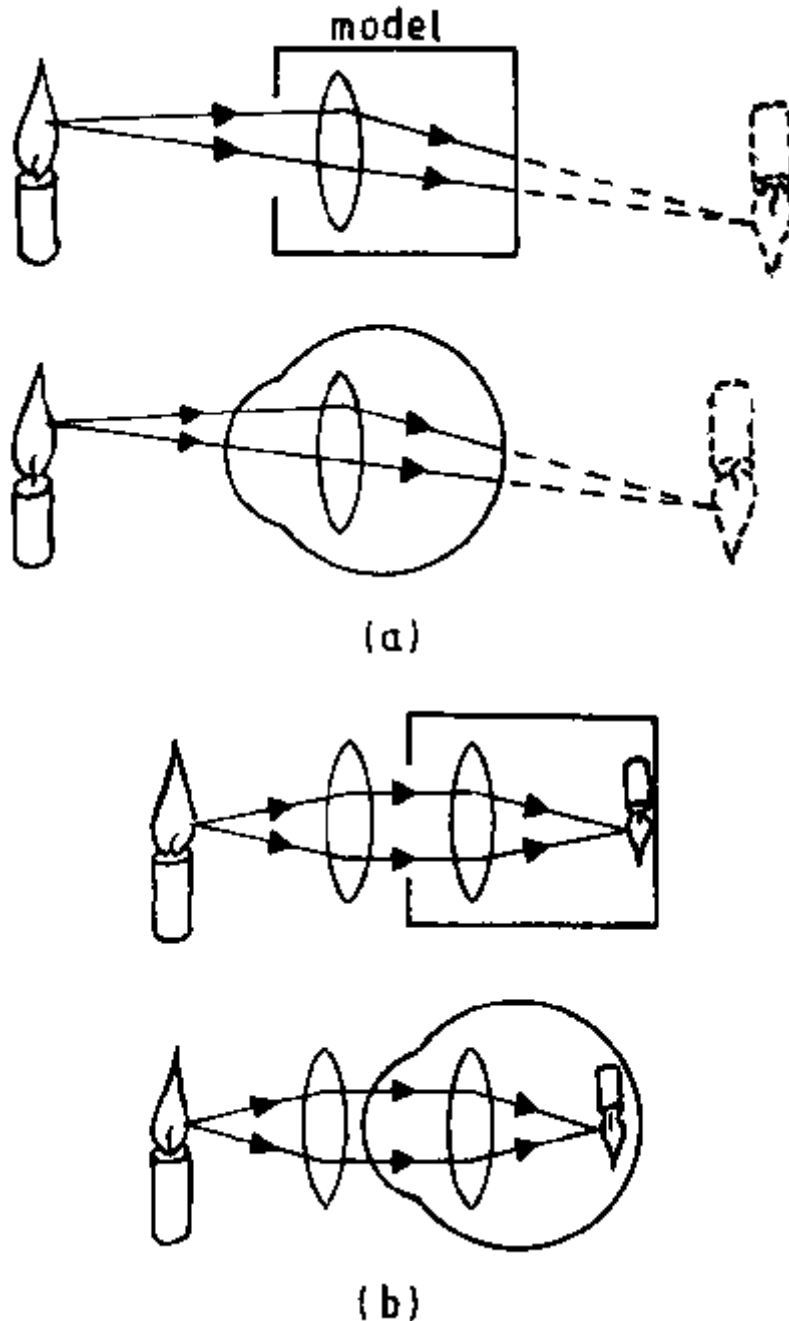

The long-sighted eye cannot focus near objects. The rays from a near object are focused *behind* the retina, see figure (a).

**P:** Make a *model of the long-sighted eye* by fixing the lens of the box camera (see p.90) so that it focusses a near candle *behind* the screen.

**Q:** How can you amend this sight defect in your model (without changing the image distance because that is *constant* in the eye)?

**E:** You need to place a convex lens of suitable focal length in front of the eye model in order to focus the near candle on the screen (retina), see figure (b). Thus, a long-sighted person needs spectacles having converging lenses.

#### 7.4.11 The Short-Sighted Eye

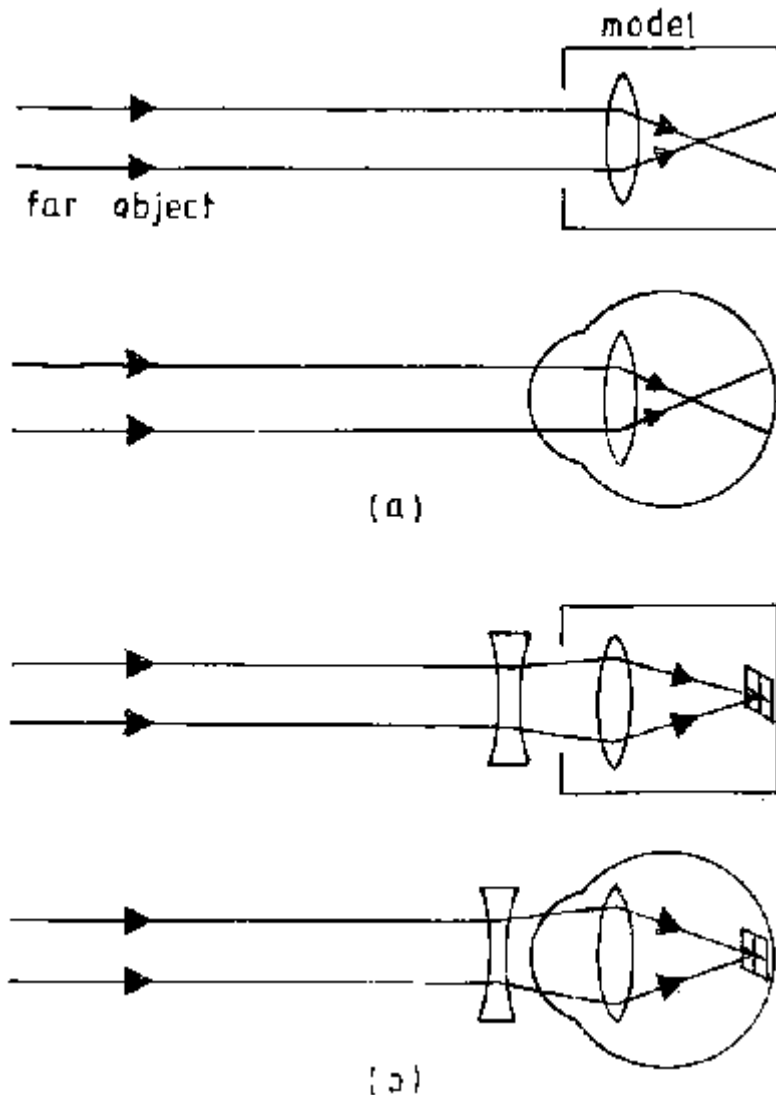

The short-sighted eye cannot focus distant objects. They are focussed *in front* of the retina, see figure (a).

**P:** Make a *model of the short-sighted eye* by fixing the lens of the box camera (see p.90) so that it focusses a distant candle *in front* of the screen.

**Q:** How can you amend this sight defect in your model (without changing the image distance because that is constant in the eye)?

**E:** You need to place a concave lens of suitable focal length in front of the eye model in order to focus the distant candle on the screen (retina), see figure (b). Thus, a shortsighted person needs spectacles having diverging lenses.

### 7.4.12 Persistence of Vision

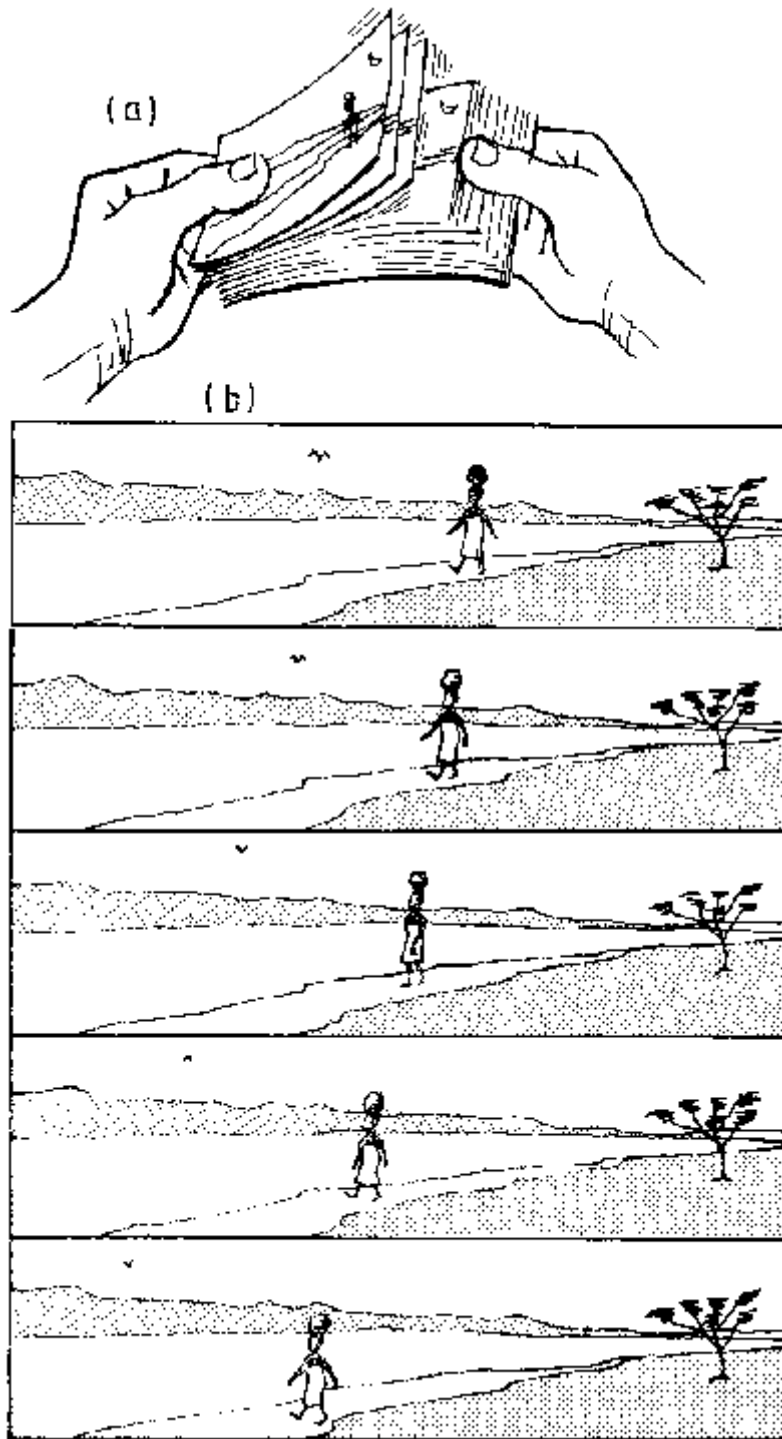

An image lasts on the retina for about one tenth of a second after the object has disappeared as can be shown by flipping cards having motion pictures as shown in figure (a).

**A:** The effect makes possible the production of motion pictures. 24 separate pictures each slightly different from the previous one, are projected on to the screen per second and give the impression of continuity.

**P:** Make eight motion pictures of a walking woman as shown in figure (b). Arrange them subsequently and hold them so that each picture comes to vision after the previous one within

a short time.

**Q:** What do you observe?

**E:** The woman appears to walk.

**A:** Movies, television, videos.

### 7.5 Dispersion and Colours

The separation of white light into its component colours is called *dispersion*. Each colour has a particular value of refractive index. Hence by passing light through a glass prism, each colour is refracted through different angles.

#### 7.5.1 Dispersion by a Glass Prism

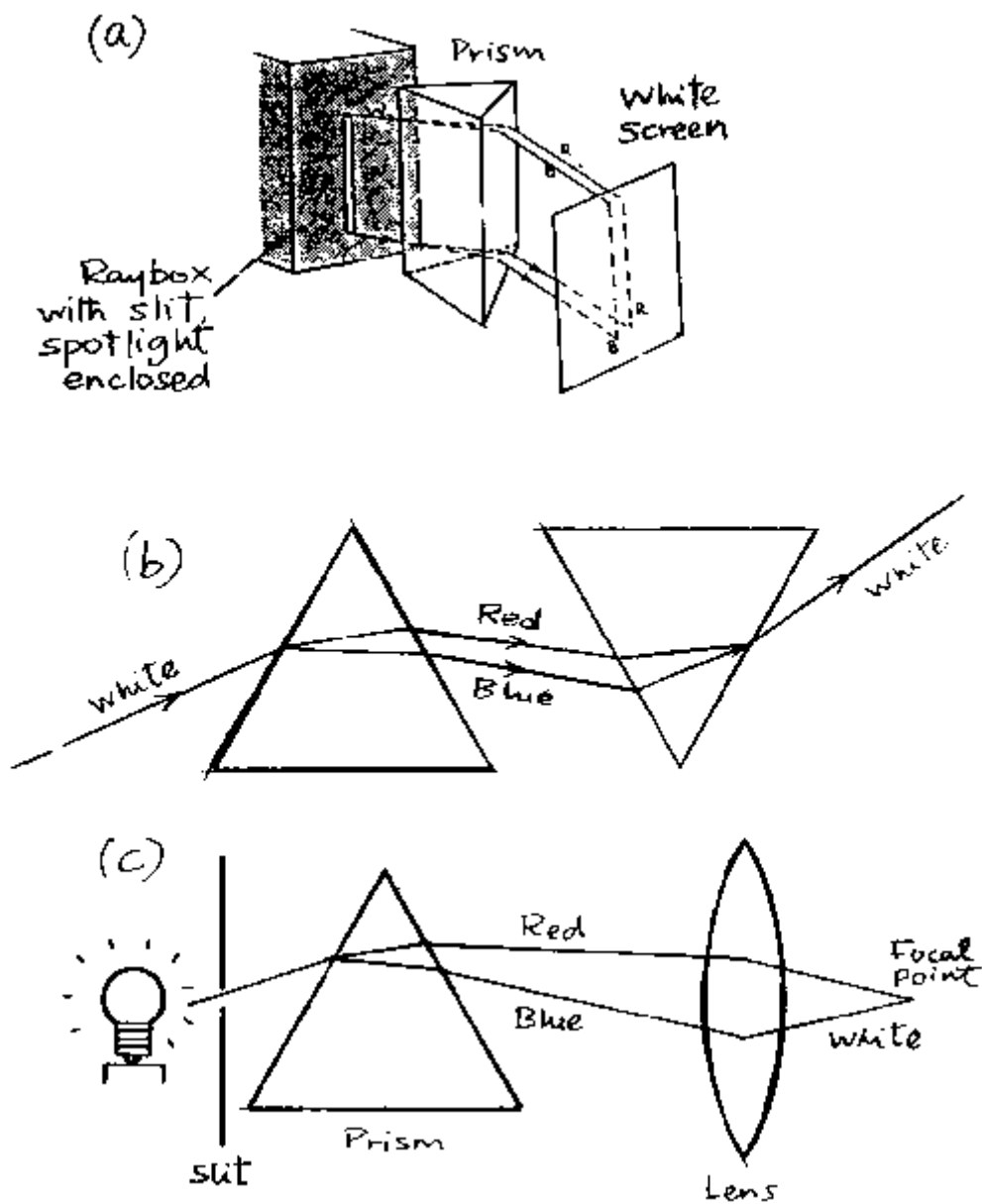

**P:** Arrange a glass prism, a narrow source of white light and a screen as shown in figure (a). Adjust the angle at which the ray hits the prism and the screen so that you catch the dispersion colours (*spectrum*)

**Q:** Which colour of light is most refracted by the prism? Which colour is least refracted by the prism?

**E:** The prism splits white light into its component colours. Blue light is refracted most and is observed nearest to the base of the prism. Red light is least refracted.

With the use of a second prism or a converging lens the separated light colours can be recombined to form white light, see figures (b) and (c).

### 7.5.2 Dispersion with a Mirror in Water

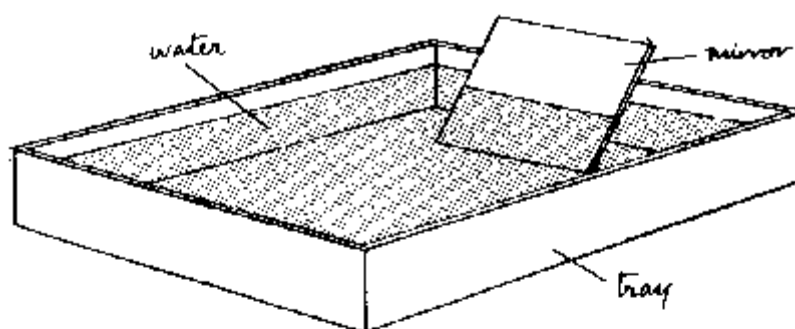

(a)

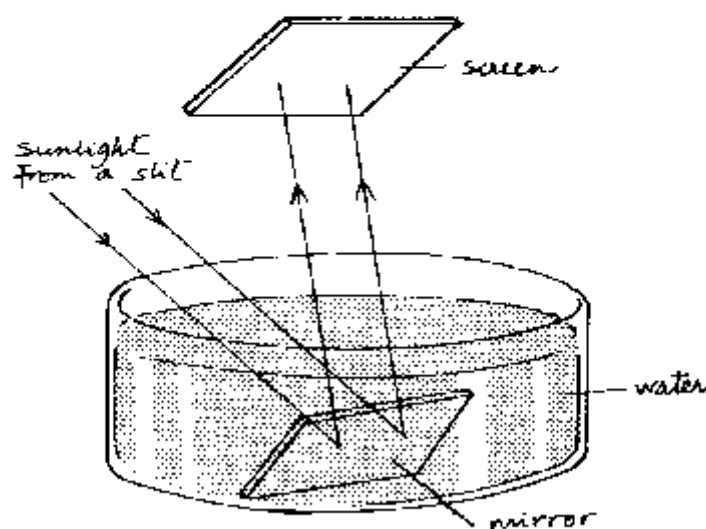

(b)

**P:** Place an inclined mirror in a container half full of water. Allow a light to strike at the slanted face of the mirror. Look through the submerged portion of the mirror, see figure (a).

**Q:** What do you observe?

**O:** The dispersion colours (*spectrum*).

**P:** Use the arrangement of figure (b) to obtain the spectrum on a screen.

**Q:** How do you explain the formation of this spectrum?

**E:** The refraction of the incident colours on the surface of the water and of the reflected rays again makes the water act as a "water prism".

### 7.5.3 Rainbow Colours from a Water Hose



**P:** Early in the morning or late in the afternoon of a bright sunny day spray water from a hose pipe against a dark background of trees with your back towards the sun, see the figure.

**Q:** What do you see? How can it be explained?

**O:** You will observe the colours of the rainbow in the spray from the hose.

**E:** The rainbow is a result of the dispersion of light rays striking water droplets.



### 7.5.4 Colour Mixing: Newton's Disk

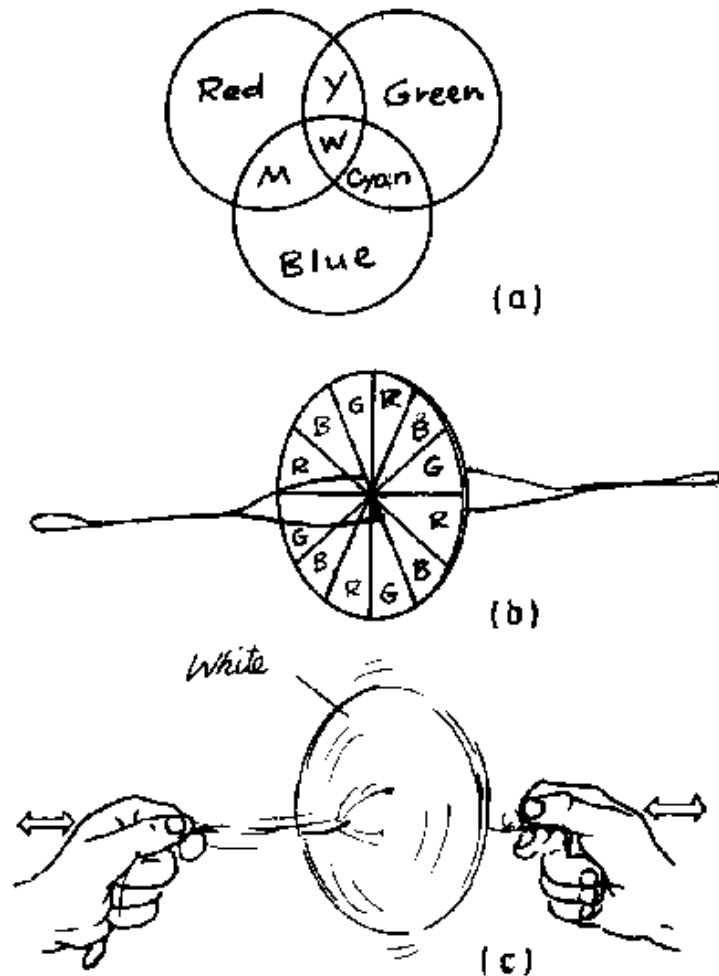

There are colours of light which when mixed in varying intensities will produce all other colours, but they themselves cannot be produced by mixing other colours. When mixed in appropriate intensities, they will also produce white light. These are the *primary colours* of light. The three primary colours of white light are *blue, green and red*. Hence BLUE + GREEN + RED = WHITE, see figure (a).

Y = yellow, M = Magenta and W = White.

*Secondary colours* are formed by adding two primary colours, e.g. Red + Green = Yellow.

So yellow is a secondary colour of red and green.

**P:** Paint twelve equal sectors of a disk made from white cardboard with red, green and blue colours arranged in that order, see figure (b). Tie a string through the two holes around the centre of disk. Swing and pull the string ends with both hands, see figure (c). The disk will start spinning to and forth.

**Q:** What do you observe on the disk?

**O:** The spinning disk appears whitish.

**E:** The colours of the light reaching the eye at short time intervals mix to white light due to the *persistence of vision*.

## 8. Magnetism and Electricity

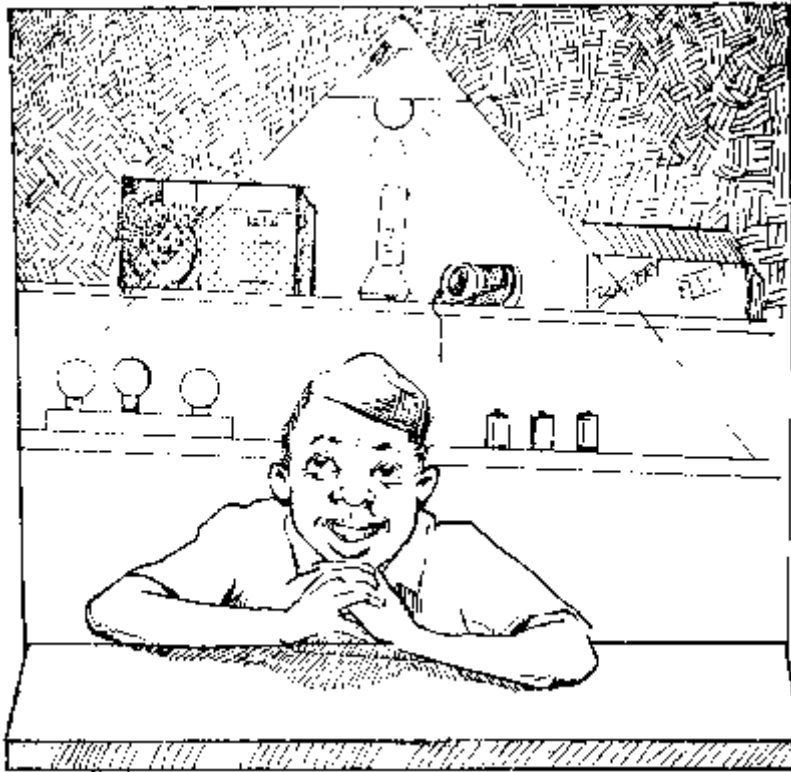

### 8.1 Magnetism

There are some materials which can attract iron. These kind of materials are said to have *magnetic properties*. The earth is a very weak magnet. Hence, a freely suspended magnet can be used as a *compass*. The end of a magnet pointing to the north is called the north (N-) pole, the end pointing to the south is called south (S-) pole. Thus, each magnet has a N-pole and a S-pole. Magnets can be found, for example, in loudspeakers and bicycle dynamos. Magnets are remarkable because they exert a force on iron or other magnets at a distance without any medium being in between. *Unlike poles attract each other, like poles repel each other.*

#### 8.1.1 Distinction of Magnetic and Non-Magnetic Materials

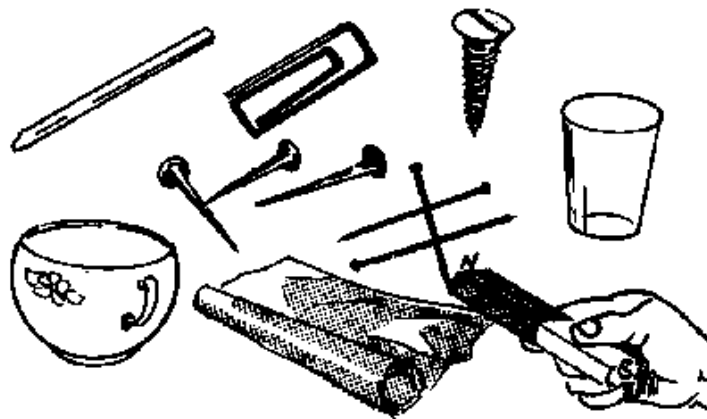

**P:** Arrange the materials shown in the diagram above on a table. Bring a magnet close to each material.

**Q:** What happens to each material?

**E:** Those materials which are attracted by a magnet are called magnetic substances. Those which are not attracted are called non-magnetic substances.

**A:** One can use a magnet to distinguish magnetic materials from non-magnetic materials. For example, you can find out if dry sand collected from outside contains magnetic materials by pushing a magnet through the sand.

**H:** The materials used in this experiment should include copper, iron, aluminium, plastic, porcelain, wood, nickel etc. if ever possible.

### 8.1.2 Interaction between Magnets

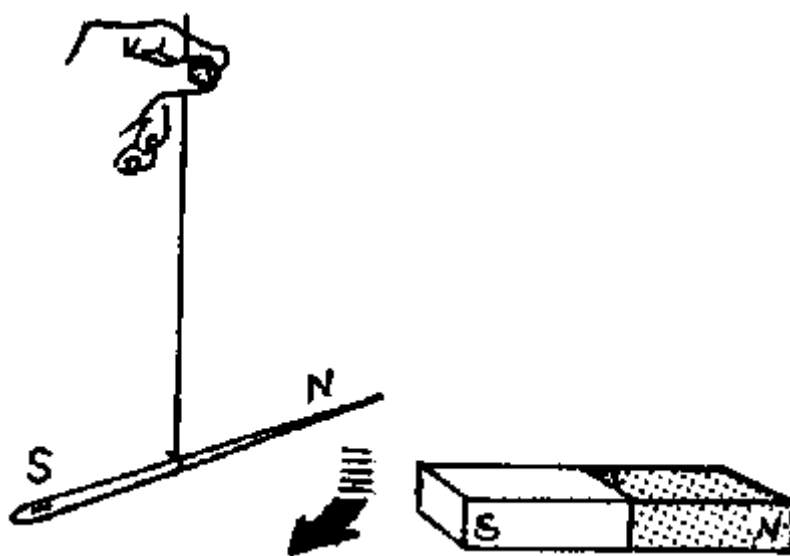

**P:** Suspend a magnetized steel needle (see experiment 8.1.3) and a bar magnet, one at a time. In each case mark the end pointing to the north as N-pole, and the end pointing to the south as S-pole.

Bring the N-pole of the magnet near the S-pole of the suspended needle.

Bring the S-pole of the magnet near the S-pole of the needle.

Now bring the N-pole of the magnet near the N-pole of the needle.

**Q:** What do you observe in each case?

**O:** You will observe that the N-pole of the magnet attracts the S-pole of the needle; the S-pole of the magnet repels the S-pole of the needle; and the N-pole of the magnet repels the N-pole of the needle. So we say *unlike poles of magnets attract each other and like poles repel each other*.

**H:** In case bar magnets are not available a magnetised piece of steel can be used instead of a bar magnet, see experiment 8.1.3.

### 8.1.3 Magnetisation by Single and Double Touch Method

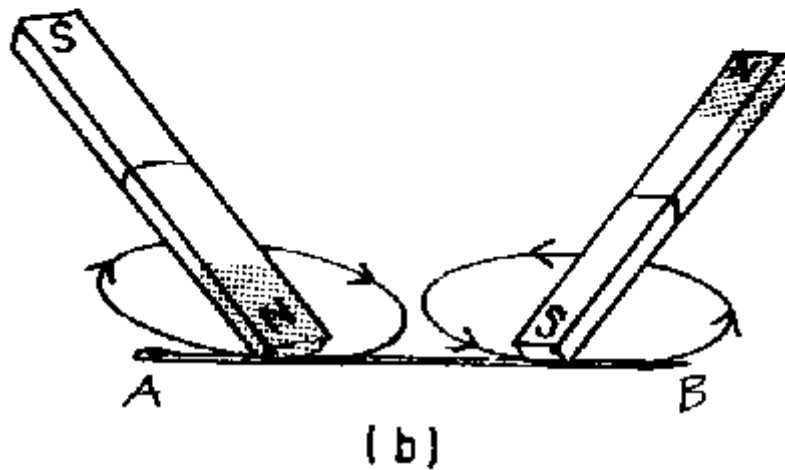
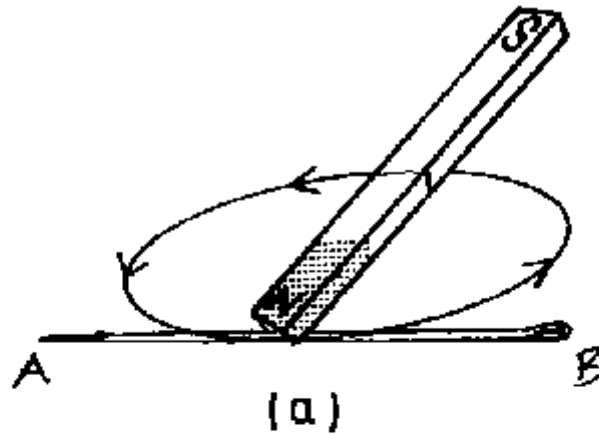

**P:** Move one pole of a bar magnet many times along the needle as shown in figure (a).

Now move the magnet along another needle as shown in figure (b). Do this several times, each time starting from the middle of the needle.

**Q:** Are the two needles magnetized? If so what are the poles of the needles?

**O:** Both needles are magnetised. The end A of the first needle is a N-pole and end B is a S-pole. The end A of the second needle is S-pole while end B is a N-pole.

**H:** The first needle has been magnetised by the single touch method and the second one has been magnetised by the double touch method.

### 8.1.4 Magnetic Ducks

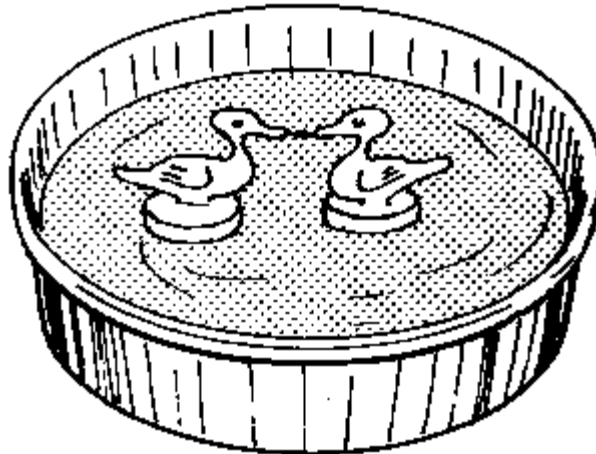

**P:** Magnetize one pin (or needle). Fix the pin or needle on the beak of one the paper ducks. Fix an unmagnetised pin on the beak of the second duck. Place the ducks to float in a bowl of water.

**Q:** What do you observe?

**O:** The beaks of the ducks come together as if they were kissing each other.

**E:** This is because the end of the magnetised pin in the beak of one duck attracts the end of the unmagnetized pin in the beak of the second duck.

**H:** To make the ducks, cut four pieces of paper in the shape of a duck and stick two of them together to make a duck. Fix each duck on a piece of wood so that it can float.

**P:** Magnetise both pins which are inserted into the beaks of the ducks and observe what happens.

### 8.1.5 Magnetisation by Electric Current

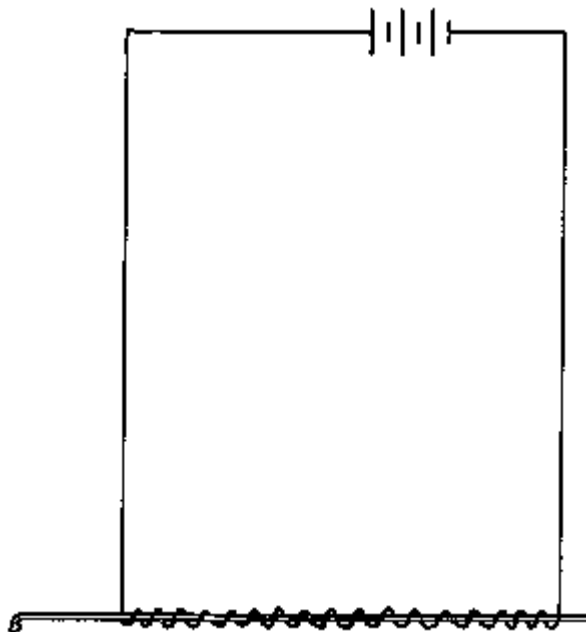

**P:** Make a coil by winding about fifty turns of isolated wire around a bicycle spoke. Connect the coil to two or three radio cells, see the figure. After a few minutes disconnect the battery and remove the spoke from the coil. Dip the spoke into iron filings.

**Q:** What do you observe?

**E:** The iron filings are attracted by the end of the spoke. The electric current in the coil has magnetized the spoke.

**H:** Steel can be magnetized by this method but soft iron *cannot*.

### 8.1.6 Demagnetisation of a Magnet

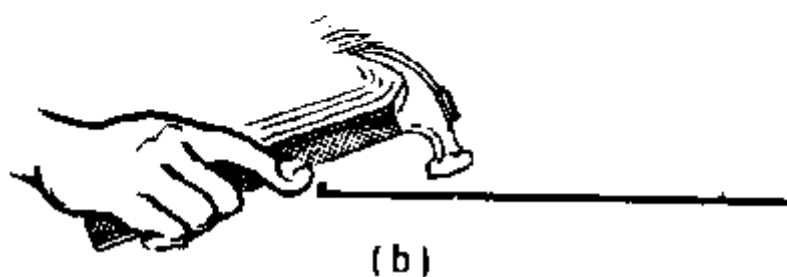
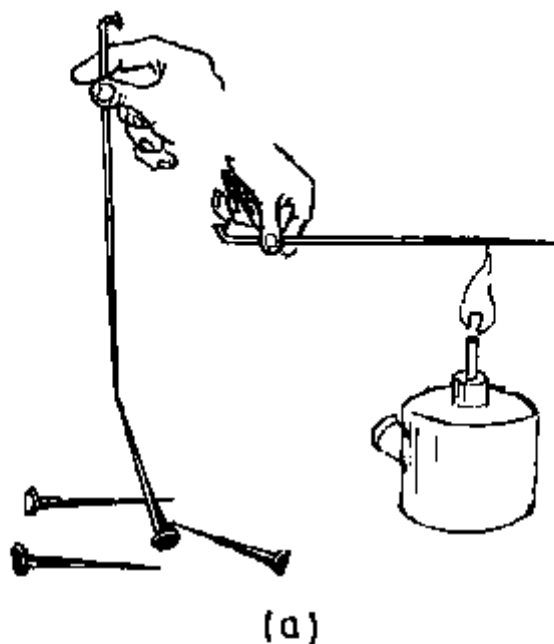

**P:** Magnetise a bicycle spoke and check if it attracts small nails or iron filings. Heat the spoke in a flame as in figure (a) and check again if it attracts the nails. Get another magnetised spoke and hammer it several times as shown in figure (b). Check if the spokes still retain their magnetism.

**Q:** What has happened to the spokes?

**E:** Heating and hammering of the spokes has destroyed the magnetism of the spokes.

**H:** Magnets should not be kept in hot places or dropped otherwise they may lose their magnetism.

### 8.1.7 Magnetic Field Pattern

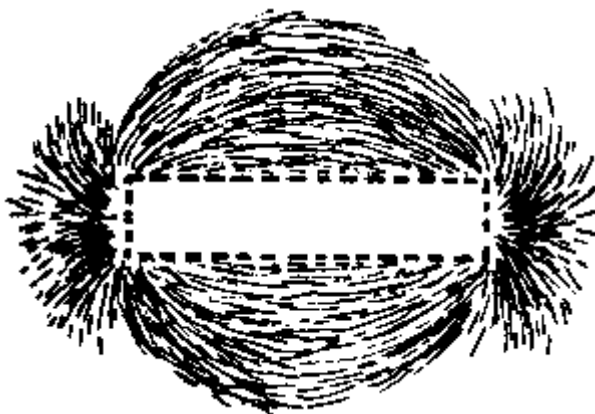

**P:** Place a cardboard on top of a permanent magnet. Sprinkle iron filings on the cardboard. Tap the cardboard gently several times.

**Q:** What pattern do you observe being formed by the iron filings? Draw a sketch diagram of the pattern formed.

**O:** The iron filings form a pattern as shown in the figure above. The iron filings are aligned along lines called *magnetic field lines* or lines of magnetic force.

**H:** Instead of iron filings small bits of iron wool may be used.

### 8.1.8 Making a Simple Compass Using a Knitting Needle

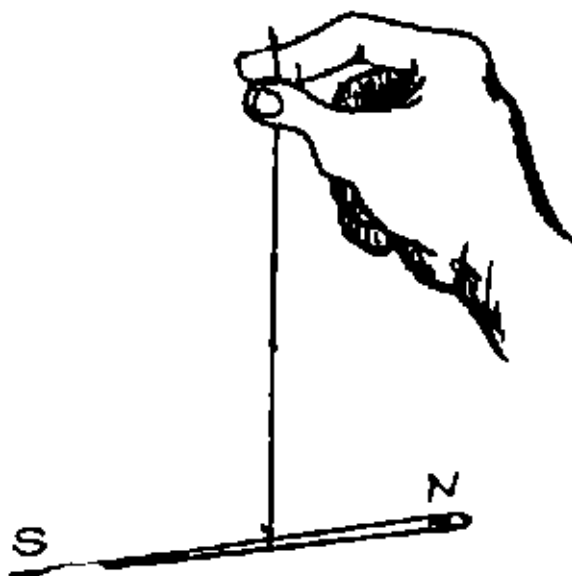

**P:** Suspend a magnetized knitting needle using a cotton thread. Allow the needle to settle and label the N-pole and S-pole of the needle.

Turn the suspended needle through various angles and release it.

**Q:** What do you observe?

**E:** You will notice that the needle will always return to settle in the N-S direction.

The suspended magnetised needle can act as a simple device to find the north-south direction.

A: Such a device which shows the N-S direction is called a *compass*.

### 8.1.9 Making a Simple Compass Using a Razor Blade

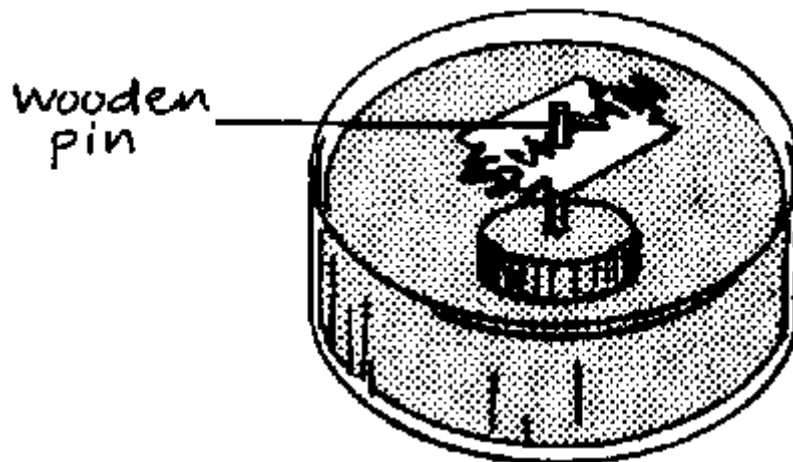

P: Fix a wooden pin vertically in a bowl of water. Slip a magnetised razor blade along the pin and carefully place it on the surface of the water so that it can rotate using the pin as an axle. Allow the blade to come to rest and mark its N-pole and S-pole.

First gently rotate the bowl. Then rotate the blade through any angle and leave it

Q: What do you observe in each case?

O: In the first case the blade will continue to lie in the N-S direction. After the blade has been rotated, it returns to lie in the N-S direction.

A: This arrangement can be used as a simple compass.

### 8.1.10 Testing for Magnets

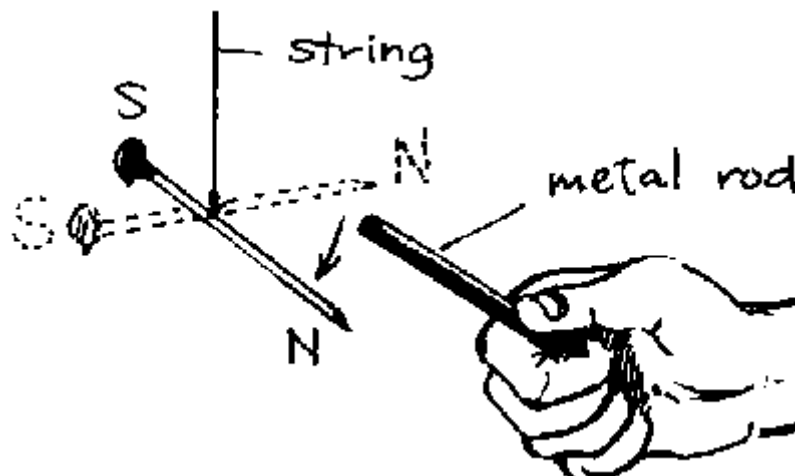

P: Bring the first end of a metal rod close to one pole of a suspended magnetized steel nail. Bring the second end of the metal rod close to the same pole of the suspended steel nail.

Repeat the above procedure with an iron rod which is magnetized.

Q: What do you observe with the magnetised and with the unmagnetised rod respectively?



**O:** With the unmagnetised rod both ends are attracted by the pole of the suspended magnet  
With the magnetised iron rod, one of its ends will be repelled. This follows from the fact that like poles repel and unlike poles attract.

**A:** This is used to distinguish magnets from unmagnetised iron.

## 8.2 Electrostatics

When plastic materials, e.g. plastic pens, combs and rulers are rubbed with fur, woolen clothes, or hair, they acquire negative *electric charges*.

When materials made of glass are rubbed with silk or polyester clothes, they acquire positive charges.

The charges acquired are stationary (static). The study of stationary electric charges is known as *electrostatics*.

*Like electric charges repel each other, unlike charges attract each other.*

### 8.2.1 Charging by Rubbing (Friction)

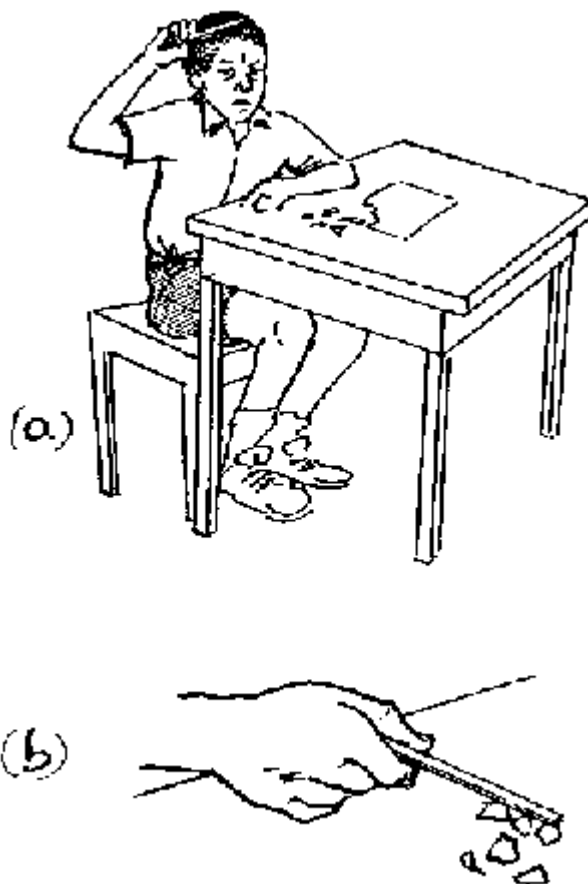

**P:** Rub a plastic pen on your hair, on woolen or synthetic clothes and bring it near small pieces of paper or pieces of thread.

Repeat the experiment by rubbing a glass bottle with a piece of "baibui" (made of silk) or polyester.

**Q:** What do you observe?

**O:** The plastic pen or glass bottle picks up small pieces of paper or thread.

**E:** The plastic pen becomes negatively charged and the bottle becomes positively charged. Thus they both attract pieces of paper.

**A:** The roller in a photocopying machine is charged positively. It attracts the paper which is being photocopied. Thus the paper sticks on the roller.

**H:** Charging by rubbing is more effective if you use dry materials during a dry day. Most of the time, electrostatic experiments won't work on a humid day.

### 8.2.2 Laws of Electrostatics

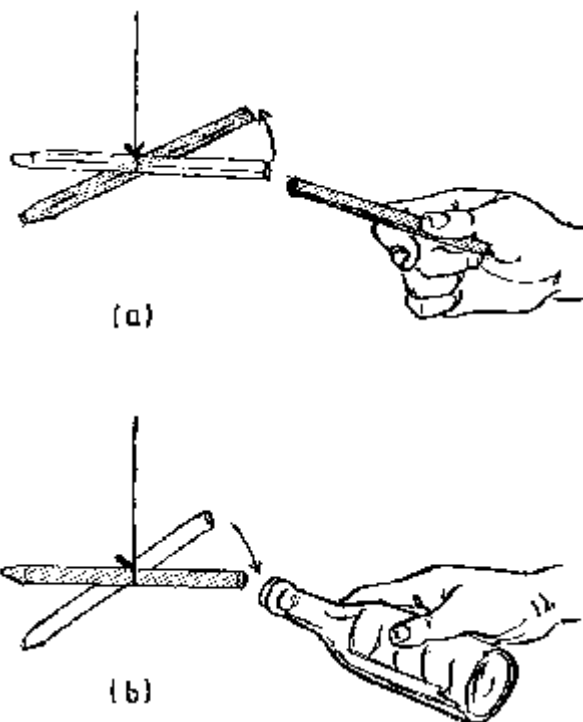

**P:** Rub a plastic pen on your hair or on a woolen or synthetic cloth and bring it near a suspended plastic pen (also charged by rubbing it on your hair).

Repeat the experiment by bringing a glass bottle charged by rubbing with silk or polyester material near the freely suspended *charged* plastic pen.

**Q:** What do you observe in both cases?

**O:** In the first experiment the two plastic pens repel each other; and in the second experiment, the plastic pen is attracted by the glass bottle.

**E:** The existence of the same types of charges (negative) on the plastic pens causes repulsion. When the positively charged bottle (glass) is brought near the plastic pen, attraction occurs.

This experiment demonstrates the electrostatic law: *like charges repel and unlike charges attract each other.*

### 8.2.3 Simple Electroscope

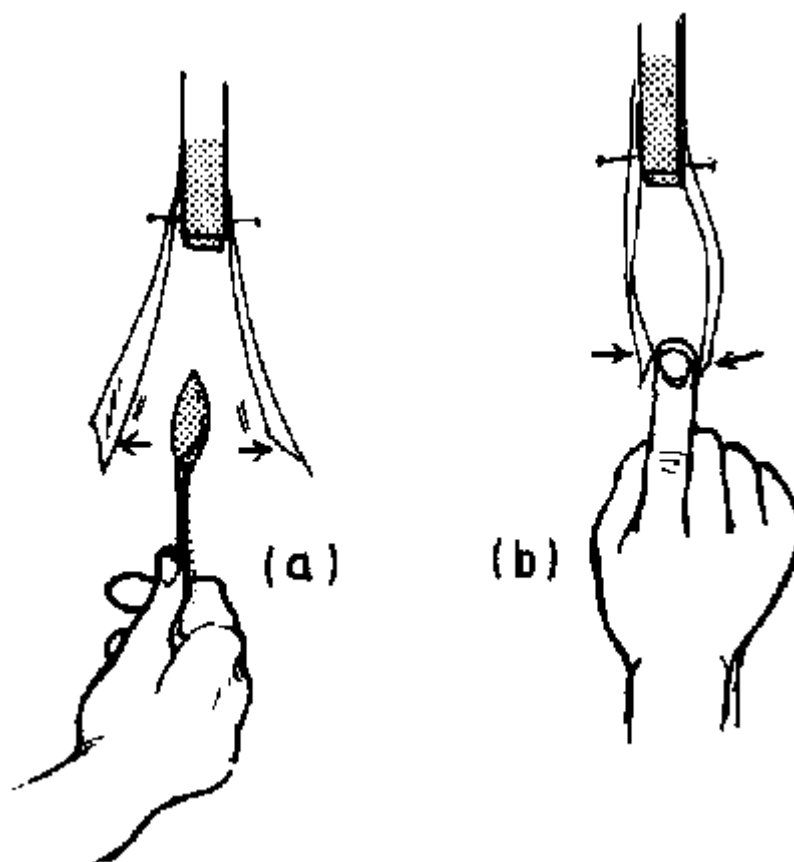

**P:** Cut two strips of polythene sheet. Fix the strips to a piece of wood as shown in the figure. Charge the strips by rubbing them with a clean duster.

(a) Introduce a charged plastic spoon between the charged strips.

(b) Introduce your finger between the charged strips.

**Q:** What happens to the strips?

**O:** The charged polythene strips repel each other.

(a) The strips are repelled further with the charged plastic spoon between them.

(b) The finger attracts the strips because the body is earthed. So it becomes positively charged relative to the two strips.

**H:** The polythene strips can be obtained from the transparent covering of a cigarette package.

**A:** The electroscope.

### 8.2.4 Electrostatic Induction

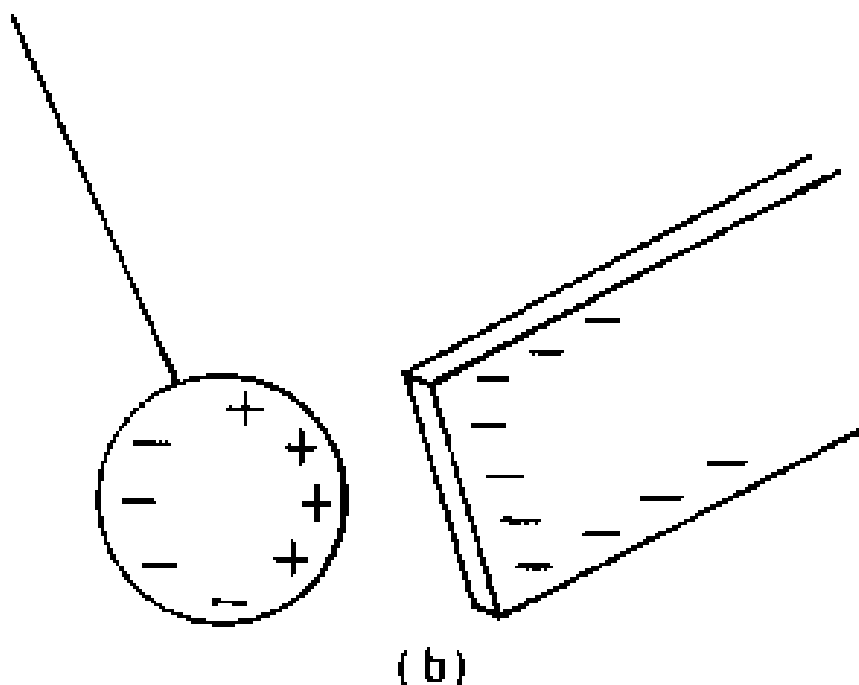
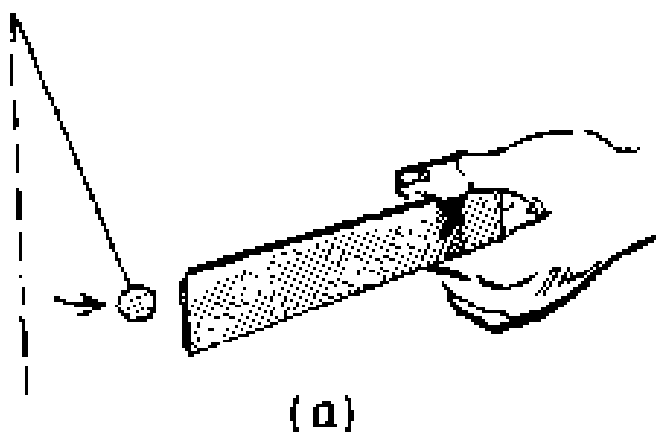

**P:** Make an aluminium ball (by using aluminium foil) and suspend it freely using a cotton thread. Bring a charged plastic ruler (negatively charged) near the aluminium ball without touching it.

**Q:** What do you observe?

**O:** The aluminium ball is attracted by the charged plastic ruler.

**E:** The force of attraction occurs due to the fact that the negative charge on the plastic ruler repels some of the electrons in the aluminium ball away from the side of the spherical surface near the ruler. Therefore the surface near the ruler gets positive charges and so the aluminium ball is attracted by the plastic. The other side of the aluminium ball becomes negatively charged, see figure (b). The process taking place in the aluminium sphere is called *electrostatic induction*.

### 8.2.5 Attraction of a Thin Stream of Water by a Plastic Object

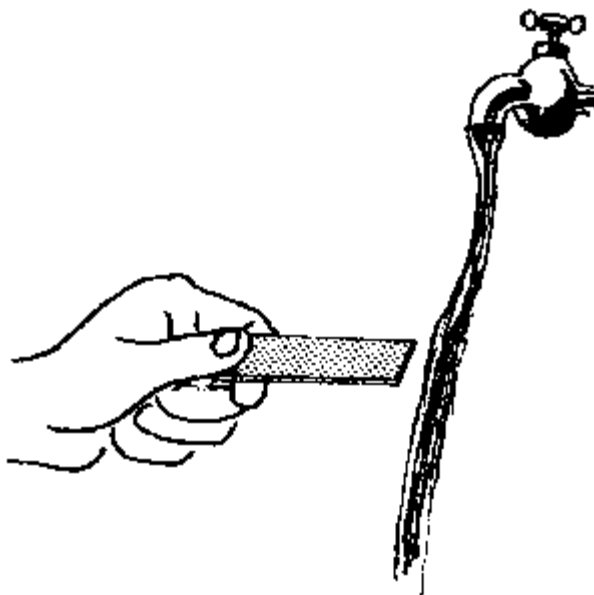

**P:** Charge a plastic object rubbing it on a woolen cloth. Then hold it near (but not touching) a thin stream of water from a tap.

**Q:** What happens?

**O:** The thin stream of water *is attracted by the plastic object*.

**E:** The negative charge on the plastic object causes the water stream to be attracted.

*(For teachers only: The water is not charged. This effect is due to the dipole nature of the water molecules. The pupils cannot understand this yet in form one or two. Since the water molecules are dipoles, they have a positively and negatively charged end, yet the total charge of the molecules is zero since the two charges balance. When the charged object comes near the water stream, the oppositely charged end of the water molecules is attracted, the other end repelled. Thus, the molecules turn so that the attracted end gets nearer to the charged object than the repelled end. Since the electrostatic forces become weaker with the increase in distance to the charged object, the attracted end of the water molecules is more attracted by the charged object than the other end is repelled. Hence, the water molecules are always attracted. It does not matter whether the object is positively or negatively charged).*

### 8.2.6 Charged Air Balloon

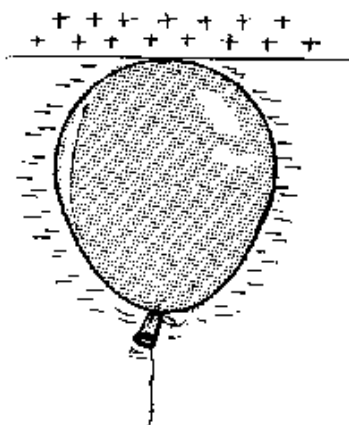

**P:** Rub a balloon on a woolen or synthetic cloth or hair and then place it against the ceiling.

**Q:** What do you observe?

**O:** The charged air balloon sticks to the ceiling.

**E:** This happens because the negative charge on the balloon repels some of the electrons in the ceiling away from the surface. This leaves the surface positively charged and so the negative balloon is attracted by the ceiling,

**H:** The experiment should be carried out during dry weather. Otherwise moisture in the air will neutralize the charges and the balloon will not stick to the ceiling. Holding the balloon with bare hands may also neutralize the charge. Try using dry paper.

**A:** Why do gramophone records tend to gather a lot of dust?

### 8.3 Electric Current

When electrons flow through a conductor they may, for example, light a bulb, heat a wire and produce a magnetic field. The flow of electrons in such a conductor is called an *electric current*. Materials, which allow a current to pass, are called *conductors*. Materials which do not allow a current to pass, are called *insulators*.

Note: If your house or school has got electricity, *never use the mains for performing the following experiments. The voltage there is quite high and could easily kill you.*

#### 8.3.1 Conductors and Insulators

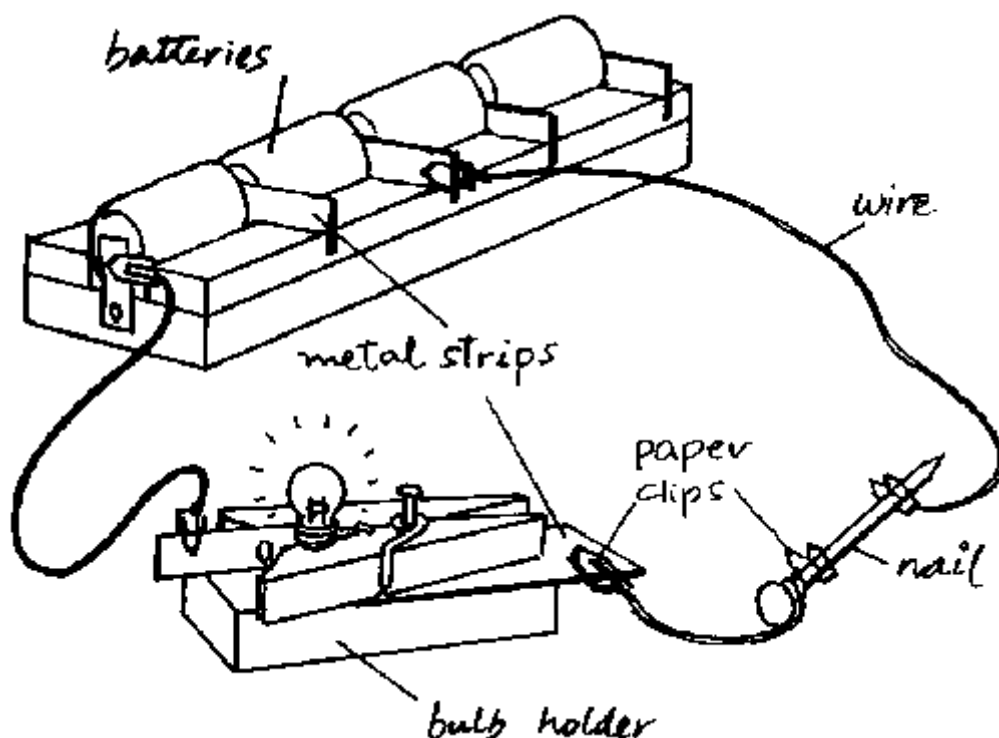

**P:** Connect a nail, a bulb and two cells with wires as shown in the figure. Successively replace the nail with cotton thread, a plastic spoon (or any plastic material), wood, aluminium foil (from a cigarette packet), paper and a piece of graphite from a pencil.

**Q:** What happens to the bulb in each case?

**O:** The bulb lights for some materials and does not light for others.

**E:** The bulb lights when current is allowed to flow through it and does not light when no current passes. The materials, which allow current to pass are called good *conductors* and those, which do not allow current to pass, are called poor conductors (*insulators*).

**H:** How to construct the bulb holder and the cell holder, refer to the figure. Note that metal plates are fixed at the end of the cells as a cell holder. For the lamp holder the metal plates are fixed on the side of the bulb and under the bulb.

Metals like copper, aluminium, iron etc. are used for connecting electric circuits. Plastics, wood, porcelain, etc. are used as insulators.

### 8.3.2 The Electric Circuit

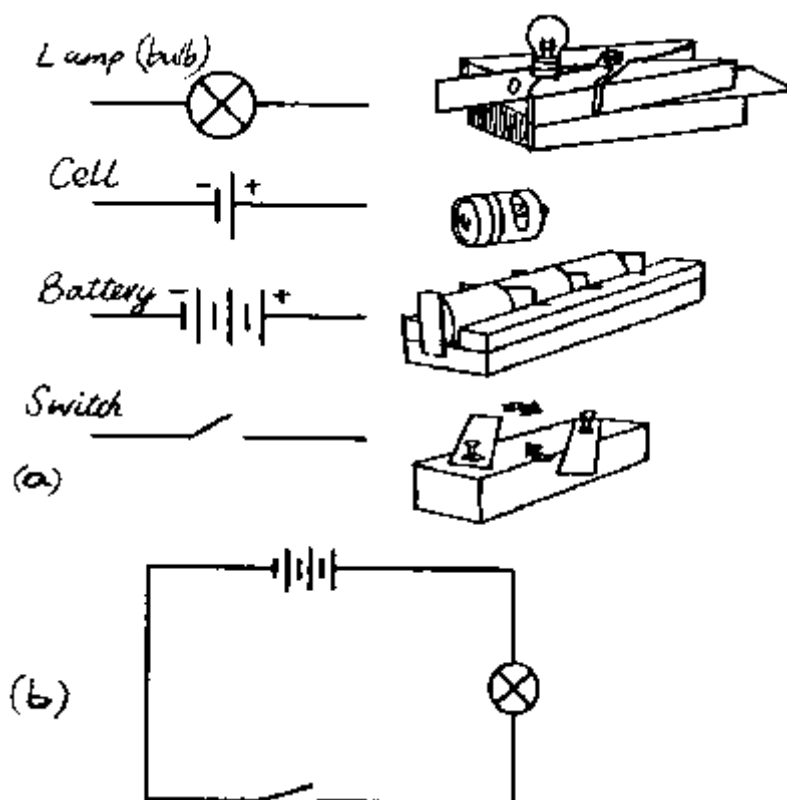

**P:** On the left side of diagram (a) we have placed the symbols used for a bulb, a cell, a battery of three cells, a switch. Connect a battery of three cells, a switch and a bulb with wires as shown in the circuit diagram (b). Close the switch.

**Q:** What do you observe at the bulb when the switch is closed?

**E:** When the switch is closed, the current flows through the bulb from the positive terminal of the battery to the negative terminal. Note, that this is *the conventional* current which flows from the positive to the negative terminal. (Of course, actually *electrons* flow in the wires from the negative to the positive terminal.) The switch makes a continuous path possible and hence the current can flow. This continuous path is called an electric circuit. In an *electric circuit diagram* we always use symbols. Every component of the circuit has its own symbol.

### 8.3.3 Bulbs in Series and Parallel

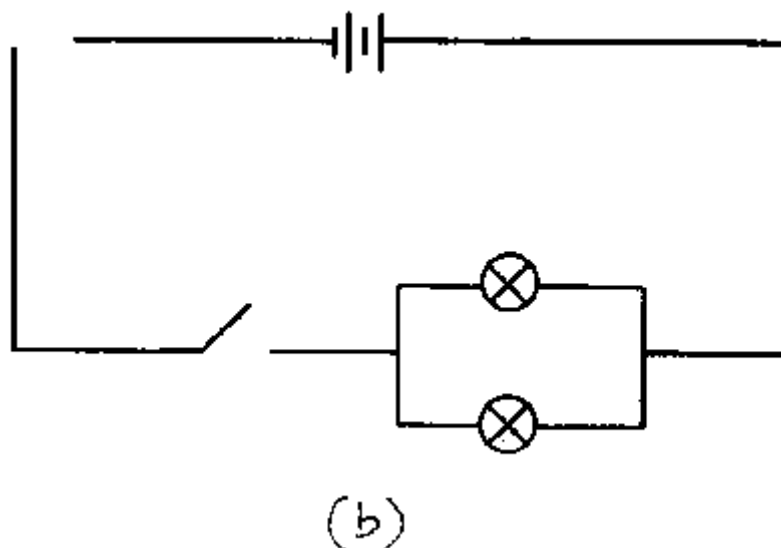
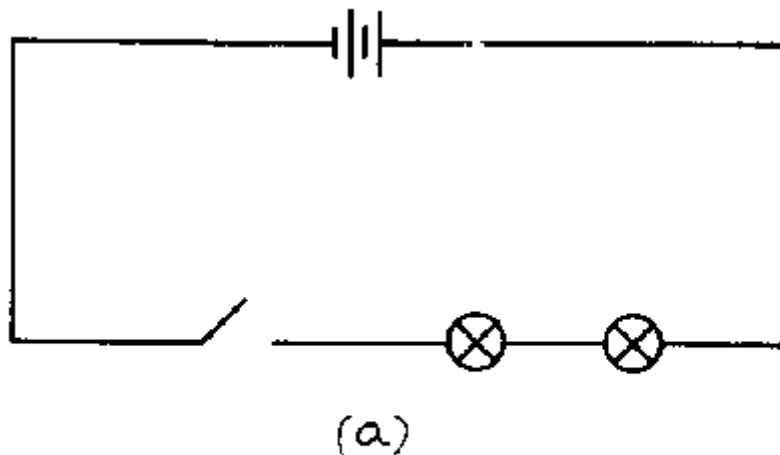

**P:** Connect two bulbs as shown in circuit diagram (a) so that they are in one line (series). Close the switch and observe the brightness of the bulbs. Now connect the bulbs side by side (parallel) as shown in circuit diagram (b). Close the switch and observe the brightness of the bulbs.

**Q:** What difference do you observe in the brightness of the bulbs when they are connected in series and when they are parallel? Explain your observations.

**O:** The bulbs are brighter when they are parallel than when they are in series.

**E:** More current passes through each bulb when they are parallel than when they are in series. The reason is that the full voltage of the battery lies on each bulb when the bulbs are connected parallel. When they are in series only half the voltage of the battery lies on each bulb.

**A:** In domestic wiring bulbs are connected parallel so that they obtain the right voltage.



### 8.3.4 Cells In Series and Parallel

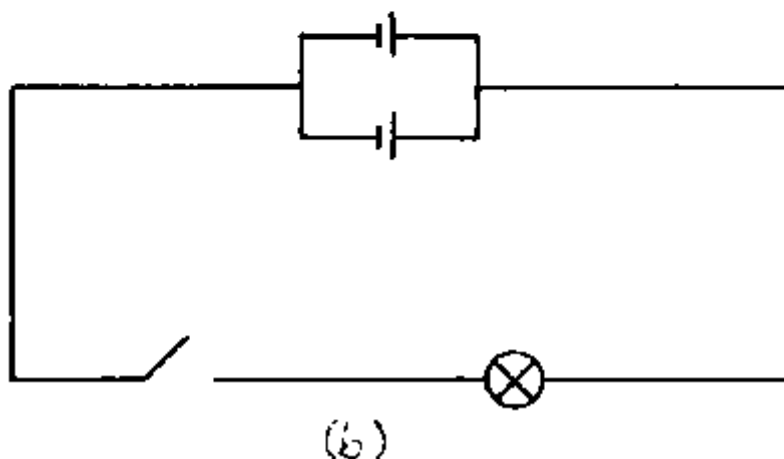
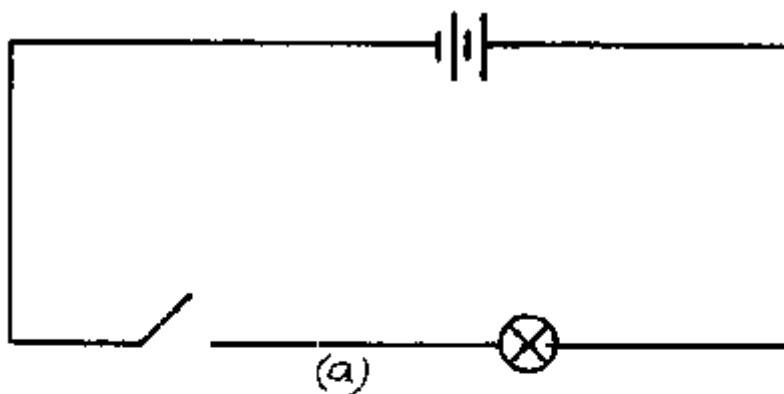

**P:** Connect two dry cells in series, that is the positive terminal of one to the negative terminal of the next as shown in circuit diagram (a). Connect the two cells parallel, that is the positive terminal of one to the positive terminal of the other and the negative terminal of one to the negative terminal of the other as shown in circuit diagram (b).

**Q:** What difference do you observe in the brightness of the bulb when the cells are connected in series as in circuit (a) and when they are connected parallel as in circuit (b)? Explain your observations.

**O:** The bulb is brighter when the cells are connected in series than when they are connected parallel.

**E:** More current passes through the bulb when the cells are connected in series than when they are connected parallel. The reason is that the *voltage* of the two cells add when they are in series. When they are parallel, the voltage stays the same as that of one cell.

**A:** In torches and car batteries cells are connected in series to get the required voltage. In cars 12 volts are needed, thus 6 cells are connected in series since one car cell has only 2 volts.

### 8.3.5 Ohm's Law: Increasing the Resistance

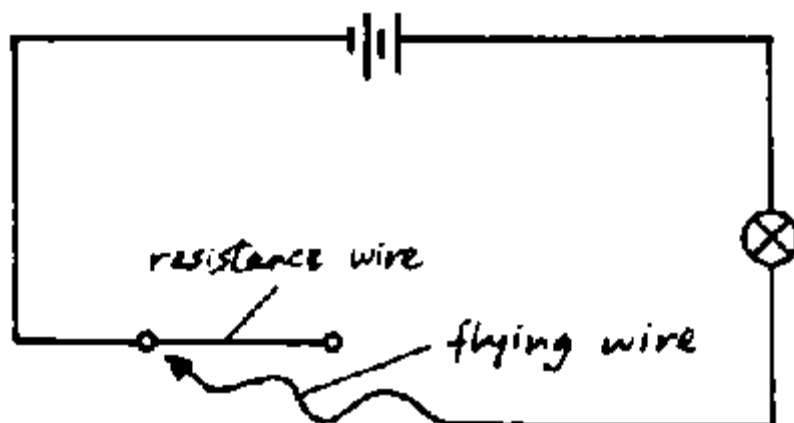

**P:** Connect the circuit as shown in the diagram. Slide the free end of the flying wire along the resistance wire.

**Q:** What happens to the brightness of the bulb?

**O:** The bulb becomes dim when the flying wire is placed at the free end of the resistance wire.

**E:** As the length of the resistance wire increases, the brightness of the bulb decreases. The current passing through the bulb decreases as the length of the wire increases, since the resistance of the wire increases.

**A:** Rheostats are long coiled wires used to vary the current in circuits.

**H:** For the resistance wire you can use a long steel wire from steel wool.

### 8.3.6 Ohm's Law: Increasing the Voltage

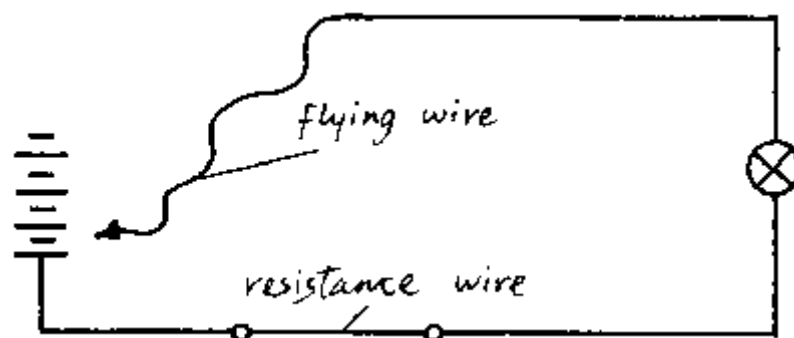

**P:** Connect the circuit above. Starting with the free end of the flying wire connected to one cell, successively increase the number of the cells.

**Q:** What difference in brightness of the bulb do you observe as the number of cells connected are increased?

**O:** The bulb becomes brighter when more cells are used than when one cell is used. The brightness increases with increase in the number of cells.

**E:** The current passing through a circuit increases with increase in the number of cells since the voltage increases accordingly.

### 8.3.7 Heating Effect of an Electric Current

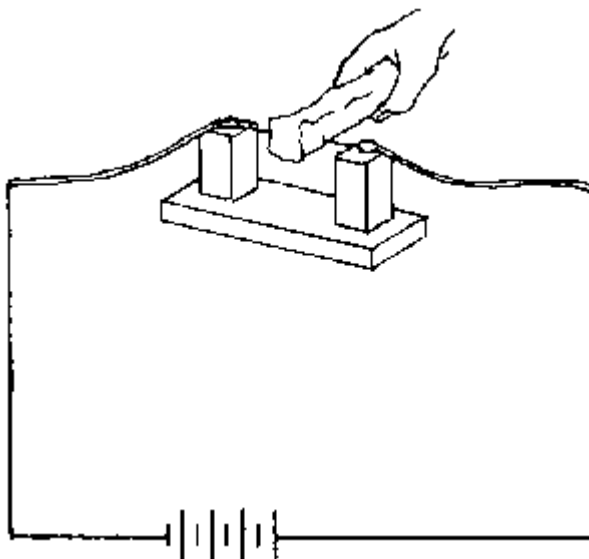

**P:** Set up the circuit as shown. Press a piece of styrofoam (polystyrene) gently across the steel wire.

**Q:** What happens to the styrofoam?

**O:** The styrofoam piece is easily cut.

**E:** The electrical energy has been converted to . heat energy which melts the styrofoam.

**A:** Electric iron, electric kettle, electric cooker etc.

### 8.3.8 The Fuse

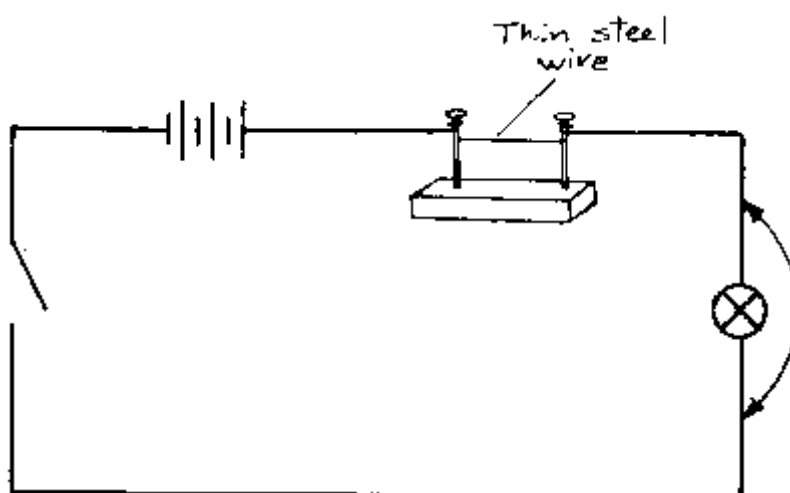

**P:** Connect the circuit as shown in the diagram. Close the switch. Make a short circuit by connecting a copper wire across the bulb.

**Q:** What happens to the thin steel wire connected across the nails?

**O:** The steel wire melts (fuses) and the bulb stops lighting. This is because a large current passes through the thin steel wire. The wire acts as a fuse.

**A:** A fuse is used in electrical appliances and domestic wiring to cut off large currents in electric circuits which could start fires.

### 8.3.9 Chemical Effect of an Electric Current

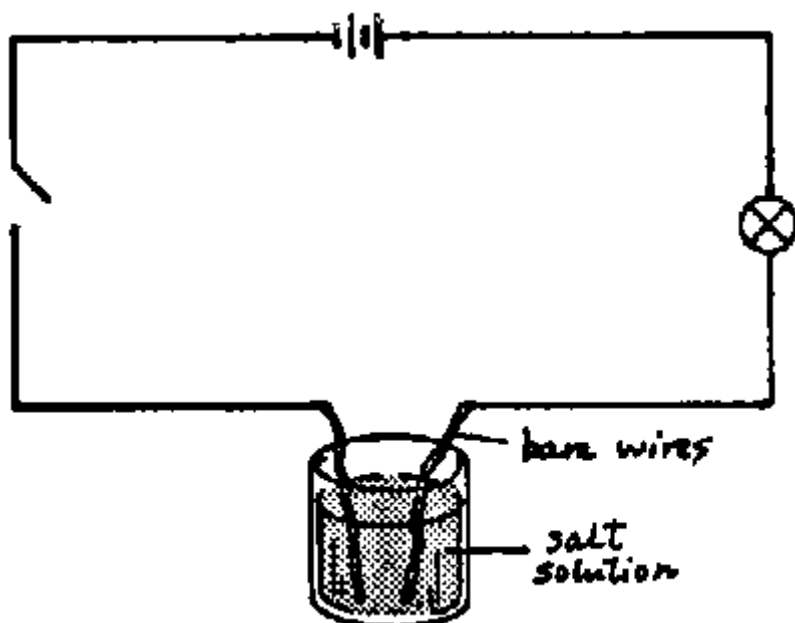

**P:** Connect the circuit shown in the diagram and close the switch so that an electric current passes through the salt solution.

**Q:** What do you observe in the salt solution?

**O:** Bubbles are produced on the bare wires in the salt solution.

**E:** When electricity is passed through a liquid like a salt solution, a chemical reaction takes place which gives off gas bubbles. This process is known as *electrolysis*.

**A:** Electrolysis is used in electroplating and coating of iron with different metals.

### 8.3.10 Magnetic Effect

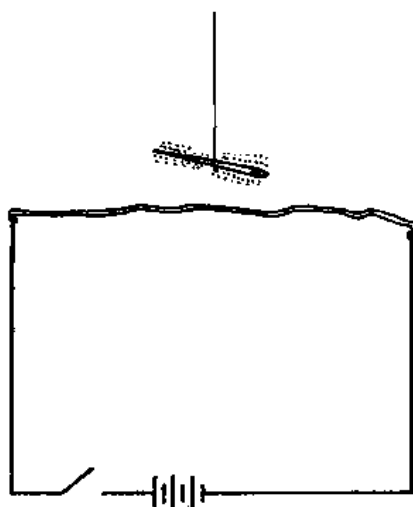

**P:** Connect the electric circuit as shown in the figure. Suspend a magnetized needle with a piece of cotton thread just above the wire. Close the switch *only for a very short time*.

**Q:** What happens to the magnetised needle?

**E:** The magnetised needle is deflected, because the wire has produced a magnetic field.

**A:** Electromagnets.

### 8.3.11 An Electromagnet

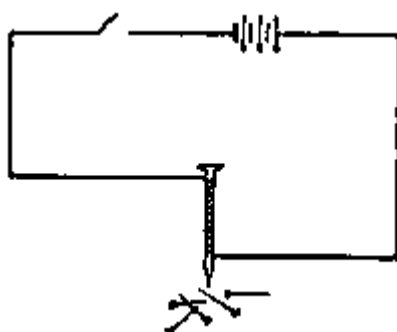

**P:** Wind about fifty turns of insulated wire around a nail. Connect the ends of the wire to the cells. Place one end of the nail close to office pins lying on the table and close the switch. After a while open the switch.

**Q:** What happens to the pins?

**O:** The pins are attracted to the nail, when the switch is closed, and fall off when the switch is opened.

**E:** When the switch is closed the current flows through the coil and magnetizes the nail. The magnet formed is known as *electromagnet*. The nail is made of soft iron. Thus it loses the magnetism when the current is switched off.

**A:** Used in harbours for lifting heavy loads with iron containers. In electric motors.

### 8.3.12 The Force on a Current in a Magnetic Field

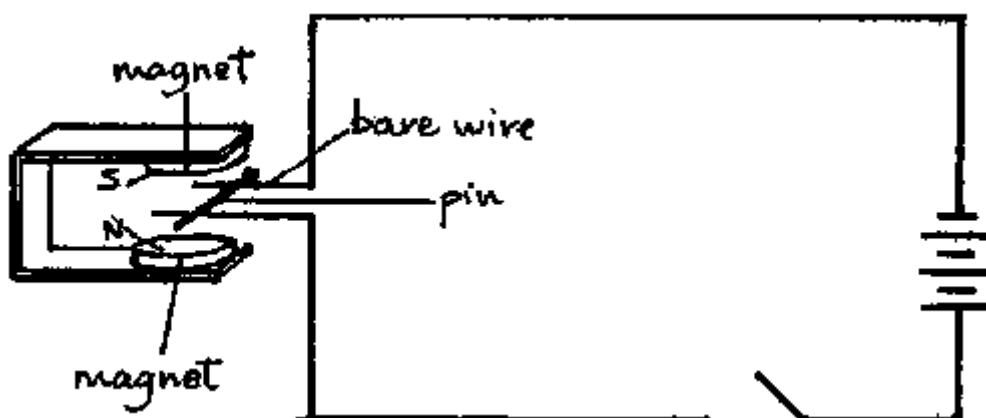

**P:** Connect the circuit as shown in the diagram. Place a nail across the straight bare wires between poles of the magnet and close the switch, *for a short time only*,

**Q:** What happens to the nail?

**O:** The nail rolls along the straight wires, because a force is produced on the current in the

nail by the magnetic field.

A: Electric motors and loudspeakers.

### 8.3.13 Opening a Dry Cell

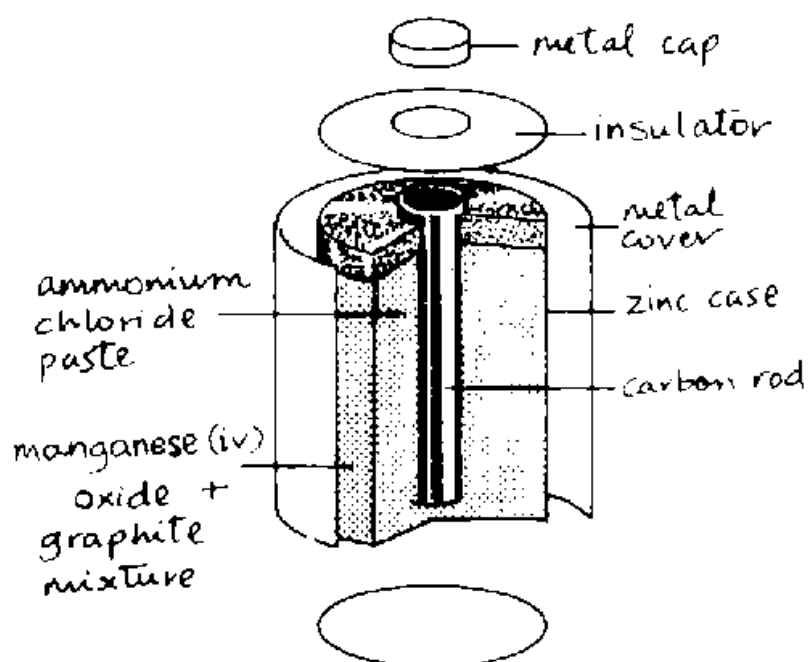
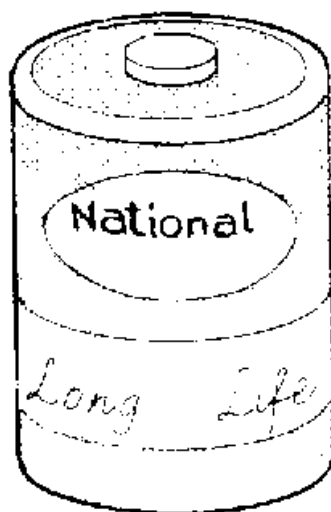

P: Open a dry cell. Examine it carefully.

Q: What do you see in the broken dry cell?

O: You will see a black rod at the centre of the cell surrounded by a black substance covered by eaten up zinc.

E: The black rod at the centre is a carbon rod (graphite). The black substance contains

manganese(IV) oxide and ammonium chloride paste.

The electrical energy is produced by a chemical reaction between the zinc and the ammonium chloride paste.

### 8.3.14 The Bicycle Dynamo

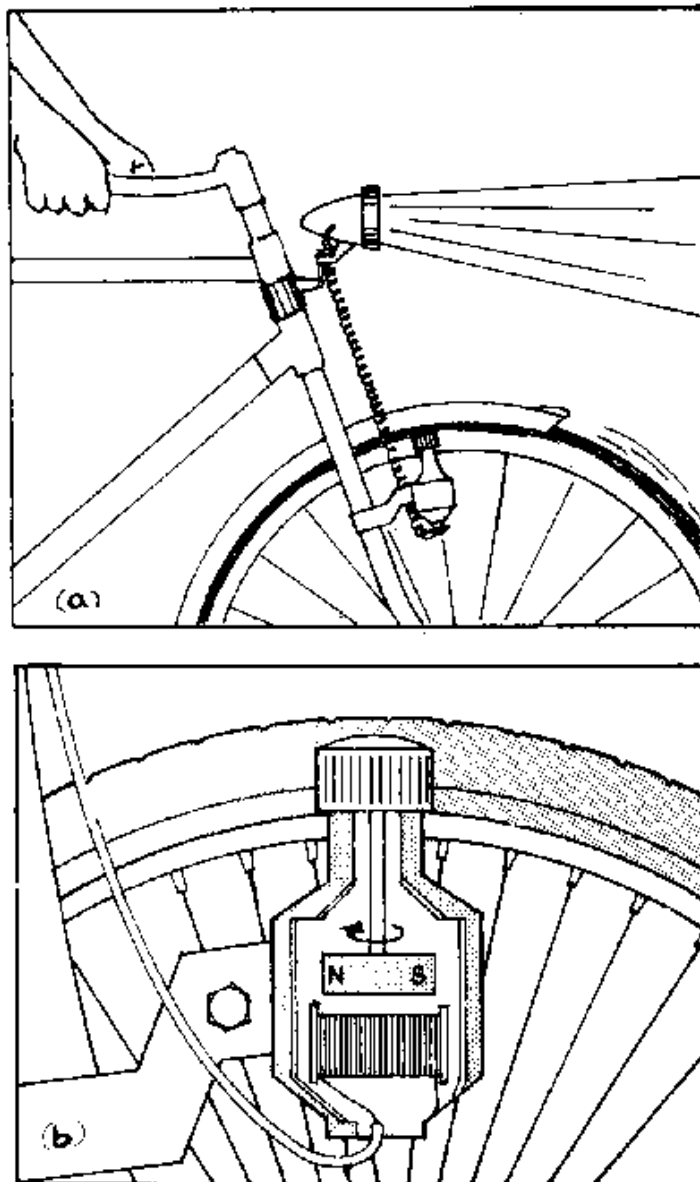

**P:** Connect a bulb to a bicycle dynamo by using connecting wires. Turn the wheel of the bicycle very fast and then slowly.

**Q:** What do you see when the wheel is turned very fast and when it is turned slowly?

**O:** When the wheel is turned very fast, the bulb gives a bright light, and when it is turned slowly, the bulb gives a dim light.

**E:** Inside a dynamo there is a magnet and a coil, see figure (b). When the wheel is turned, it makes the magnet rotate. The rotation of the magnet near the coil produces a current in the coil. The amount of current produced increases with the speed of rotation of the magnet.

**A:** Electric Generators.

## Appendix

### A Sootless Kerosene Burner

Spirit for burners is not always available, but kerosene can be purchased nearly everywhere. For the heating of tins or other things a sootless *kibatari* (kerosene burner) will do.

With a simple and cheap additional device which the same 'fundi' can make who produces the normal *kibatari*, you can get a nearly sootless flame. The principle behind is to improve the draft of the air stream in order to obtain a *more complete combustion* of the kerosene. The flame of the *kibatari* should burn in contact with a metal wall, which acts as a catalyst.

The basic device consists of 4 parts:

(a) A *perforated inner chimney* is made from a tin which is about 1.3 cm wide and 7 cm long. If the diameter of this tube is too small, the flame will not burn; if it is too wide the effect will be small. The holes can be made with a nail and should have a diameter of 2 mm. There should be 3-4 holes per square centimetre.

(b) An *outer chimney* which serves at the same time as a wind shield. The holes below are about 5 mm in diameter.

(c) Both chimneys fit together in a *perforated soda bottle cap* as shown.

(d) Ask the fundi to solder another soda bottle cap around the *wick holder (d)*. This holds the chimneys better.

The flame is optimized by adjusting the length and shape of the wick: it should have contact with the perforated tube. With this burner temperatures of about 650°C can be achieved.



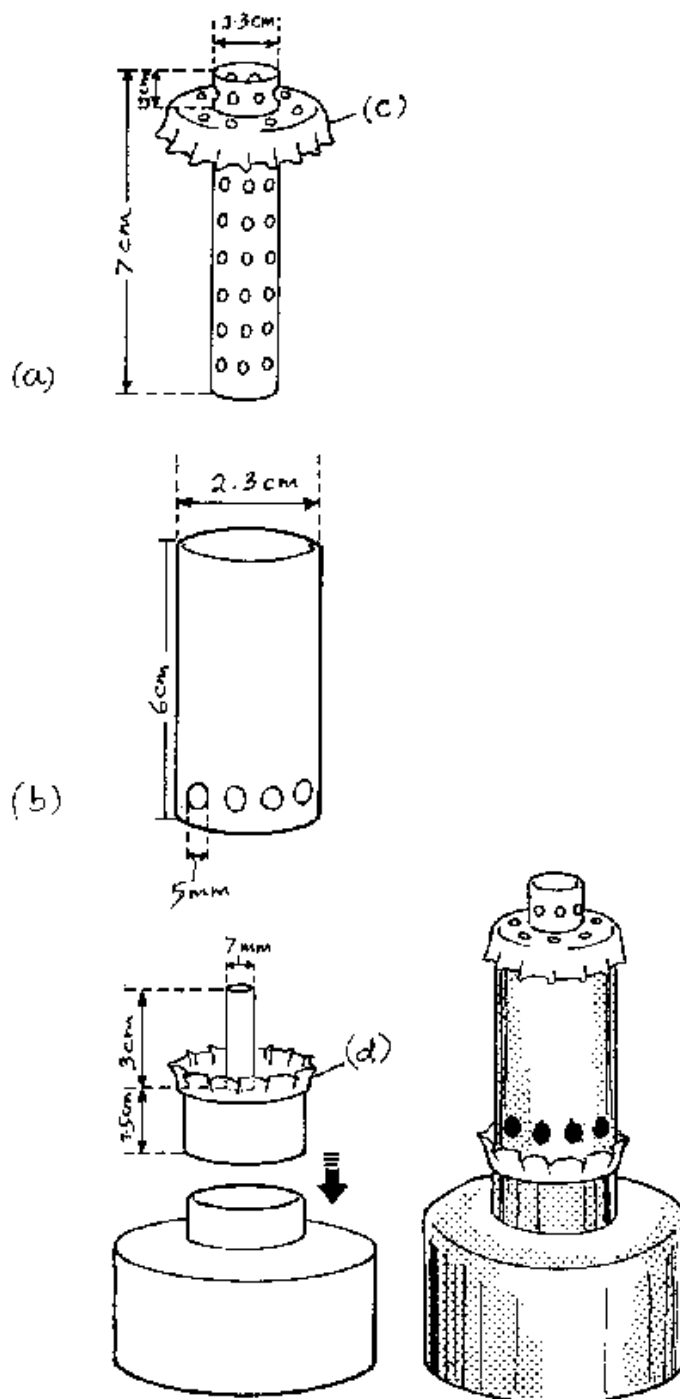

### Test Tubes and Flasks

A cheap substitute for expensive test tubes and reaction flasks are opened worn out electric bulbs. They resist the temperature of an alcohol or kerosene burner, but *not* the temperature of a bunsen burner. Heat the bulbs carefully and do *not* use them for aggressive substances like *concentrated* acids and hydroxides.

Bulbs can be opened with pliers and a round file or even with a pointed long nail. Wrap your hand with a piece of cloth. Never hold the bulb to be opened at its glass, hold it only at its socket, see figure (a).

Special clamps are not needed. Fold a sheet of paper and you have the cheapest test tube or bulb clamp, see figures (c).

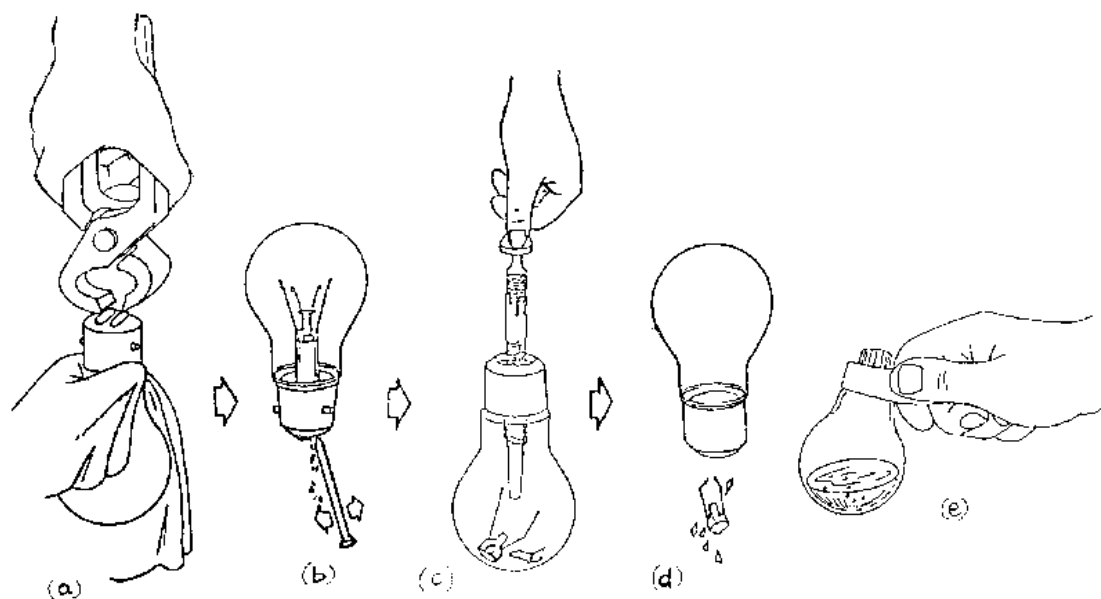

### List of Materials

This is the list of materials needed for a workshop on "Teaching Physics to Beginners with Locally Available Materials."

It is assumed that the organisers will bring the materials which are needed for each kit and the tools listed below. These, therefore, are not mentioned especially under the numbered experiments below. Common materials like water, etc. are not mentioned.

The materials listed allow to produce the *Physics kit* with which the experiments described in this book can be performed. Each participant of a workshop should produce his/her own kit according to the experiments he/she selects.

### Materials (needed for each kit)

Matches  
 Wooden rulers  
 Opened (transparent) bulbs (and if possible some test tubes)  
 Some vibatari (kerosene lamps; if possible with chimneys for a sootless flame).  
 Cement bag or similar paper  
 Nails of different diameters  
 Thumb pins  
 Office pins  
 Paper clips  
 Small and medium size tins for heating  
 Some transparent bottles with smooth surface  
 Some transparent glass jars  
 2-3 candles  
 Glue

### Tools etc. (needed only once)

1 sharp knife  
 1 combination plier  
 1 hammer  
 1 set of weights  
 1 balance (see p. 10)  
 1 measuring cylinder

- 1 magnet (e.g. from a discarded loudspeaker)
- 1 drill borer for 2-3 mm holes
- 1 tin opener
- 1 pair of plate-shears
- 1 pair of scissors

**To be done by craftsmen:**

Chimney for sootless kibatari (see p. 109)

Funny jumper (see p.21)

Box with lid and handle for physics kit, see the figure below

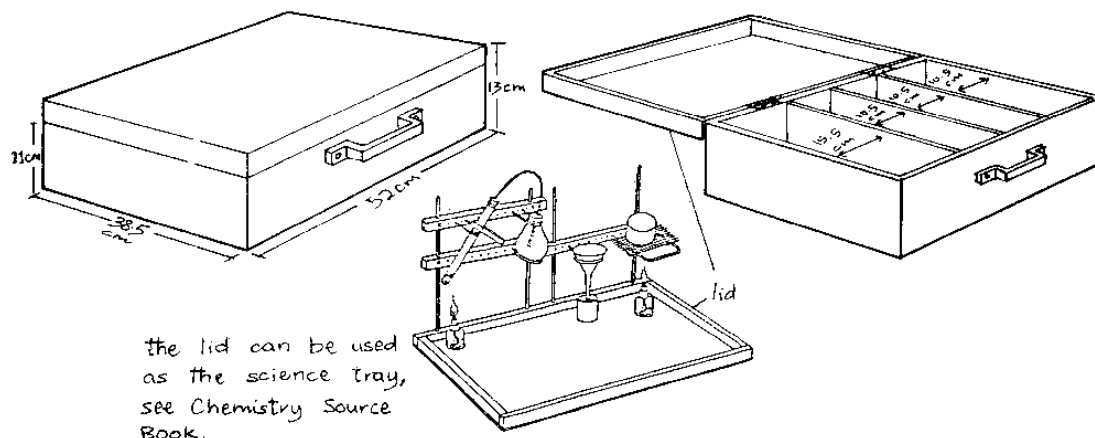

In addition to the materials listed above you need the following materials according to the experiments you choose:

- 2.1.1 Rubber band, thin wire, small plastic bags (groundnuts)
- 2.1.2 Bicycle, meter band
- 2.1.3 Thread, nut or small stone
- 2.1.4 Watch, meter band (better 10 m thread)
- 2.1.5 Thread, wooden ruler, small plastic bags, thin wire
- 2.1.6 Clothes-peg, wire (2 mm), thread
- 2.1.7 Plastic bags (groundnuts)
- 2.1.8 Small plastic bags (groundnuts)
- 2.1.9 -
- 2.1.10 Wooden stick, kerosene
- 2.1.11 -
- 2.1.12 5 m string
- 2.1.13 -
- 2.1.14 -
- 2.1.15 Sewing needle (or a piece of bicycle spoke), insulated wire, 1.5 V dry cell
- 3.1.1 Matchbox, smooth table or plank, some bricks, a small stone
- 3.1.2 The same as 3.1.1
- 3.2.1 A stone, a rubber band, a ball of mud
- 3.2.2 Card board or wooden lath, rubber band
- 3.2.3 -
- 3.2.4 -
- 3.2.5 Newton balance, see p. 15
- 3.2.6 -
- 3.3.1 Stone
- 3.3.2 A large and a small stone, string, ball
- 3.3.3 Newton balance, see p. 15
- 3.3.4 Beam balance, weights, see p. 10
- 3.3.5 A pencil, a strip of paper, (table)
- 3.3.6 A toy pick-up or an open box, some card
- 3.3.7 A large paper

- 3.3.8 A large paper
- 3.3.9 A large paper
- 3.3.10 A large paper
- 3.4.1 Sheet of cardboard, thread, 7 equal clothes-pegs
- 3.4.1 Sheet of cardboard, stone, string, pencil
- 3.4.3 -
- 3.4.4 14 nails of 2-inch length, piece of wood
- 3.4.5 Pencil
- 3.4.6 A candle, some card
- 3.4.7 A coin, 2 forks
- 3.4.8 A potato, 2 forks, pencil, bottle, some card, string
- 3.5.1 Wooden stick, a flat piece of wood
- 3.5.2 Book, table, piece of cloth
- 3.5.3 Oil or margarine
- 3.5.4 -
- 3.5.5 Book, about five round pencils or drinking straws
- 3.5.6 Large paper
- 3.6.1 Stone, thread, Newton balance (see p. 15), measuring cylinder
- 3.6.2 Rubber stopper, piece of glass or transparent plastic tubing, beam balance, (see p. 10)
- 3.7.1 Book, pencil
- 3.7.2 -
- 3.7.3 Bucket, a 'ngata'
- 3.7.4 Plastic bag
- 3.7.5 Large tin with air-tight lid, e.g. a charcoal stove, small tin or cup
- 3.7.6 Drinking glass or jam glass, smooth card or plastic sheet
- 3.7.7 Bottle, plastic bag, string, straw
- 3.7.8 A piece of transparent plastic tubing, string
- 3.7.9 Plastic or rubber tube
- 3.7.10 One way syringe from a hospital
- 3.7.11 Bicycle pump, large paper
- 3.7.12 Large paper
- 3.7.13 Large paper
- 3.7.14 Large paper
- 3.8.1 Stone, thread, Newton balance, measuring cylinder
- 3.8.2 Matchbox, small stone, Newton balance, overflow can (see p.25), measuring cylinder
- 3.8.3 Bottle, small piece of styrofoam
- 3.8.4 Drinking straw, a piece from a plastic bag, thread, bottle or test tube
- 3.8.5 Salt, egg
- 3.8.6 Candle
- 3.9.1 Wooden block, Newton balance, thread
- 3.9.2 Like 3.9.1
- 3.9.3 Rubber band, stone, branched stick
- 3.9.4 Stopper, used bulb, paper, burner
- 3.9.5 Stone, string
- 3.9.6 3 clothes-pegs, thread, matches
- 3.9.7 Funny jumper (see p.21)
- 3.9.8 String (to measure height), stone, watch
- 3.10.1 Heavy stone, tipped stone
- 3.10.2 Wooden block and bar, some weights (see p. 10), string
- 3.10.3 Wooden lath, wire (diameter 2 mm), 1 cork, card, string
- 3.10.4 Two pulleys (see 3.10.3), string, Newton balance
- 3.10.5 Two broomsticks, rope of about 5 m length
- 3.10.6 Table or plank, some bricks, toy car, string, Newton balance
- 3.11.1 Wire (2 mm), thin wire, 1 seed, 1 small fruit, 1 bulb (1 torch bulb, battery, connecting wires), 1 bottle
- 3.11.2 Stone, string
- 3.11.3 Long string for measuring distances
- 3.11.4 -
- 4.1.1 Some salt
- 4.1.2 -

- 4.1.3 Pieces of cotton, canvas cloth, small polythene bag
- 4.2.4 Orange peels
- 4.2.5 Umbrella or big plastic sheet
- 4.1.6 Simple balance (see 2.1.5)
- 4.2.1 -
- 4.2.2 -
- 4.3.1 Some potassium manganate(VII) (permanganate; or other solid colouring agents)
- 4.3.2 -
- 4.3.3 -
- 4.3.4 -
- 4.3.5 -
- 4.3.6 -
- 4.4.1 2 clean glass pieces (of a broken window)
- 4.4.2 -
- 4.4.3 Razor blade, fork
- 4.4.4 -
- 4.4.5 Some detergent or soap
- 4.4.6 2 glass sheets of about 10 cm x 10 cm, rubber bands or string
- 4.4.7 Stick of chalk, plotting paper or newspaper
- 4.4.8 Piece of cloth
- 4.4.9 Thread
- 4.4.10 -
- 4.5.1 Rubber band, plastic bags (groundnuts)
- 4.5.2 2 tall small bottles (or test tubes)
- 5.1.1 -
- 5.1.2 Small bottle, cork stopper, empty ball point tube
- 5.1.3 Large sheet of paper, ruler, writing facilities
- 5.1.4 Some oil
- 5.1.5 -
- 5.1.6 -
- 5.2.1 2 Wooden blocks, 30 cm wire (about 2 mm diameter), pin needle
- 5.2.2 -
- 5.2.3 2 razor blades, 1 clothes-peg
- 5.2.4 Thin copper wire (from used motor coil)
- 5.2.5 -
- 5.2.6 Aluminium paper from cigarette packages
- 5.2.7 The same as 5.1.2
- 5.2.8 -
- 5.2.9 Soda or beer bottle
- 5.2.10 The same as 5.2.9, plus tin for a water bath
- 5.3.1 Some ice
- 5.3.2 -
- 5.3.3 Some spirit or petrol
- 5.3.4 -
- 5.3.5 -
- 5.3.6 -
- 5.3.7 Piece of ice
- 5.3.8 Some salt, piece of ice, plastic dish (or plate)
- 5.3.9 -
- 5.3.10 -
- 5.4.1 A ball (from children)
- 5.4.2 -
- 5.4.3 Wire, plastic rod, wooden rod (all of similar size)
- 5.4.4 30 cm wire (2 mm diameter)
- 5.4.5 -
- 5.4.6 Saw dust
- 5.4.7 -
- 5.4.8 Shiny tin, 2 wooden sticks
- 5.4.9 2 identical shiny tins
- 5.4.10 -

- 6.1.1 A rope of about 6 m length
- 6.1.2 Tin, string, some newspaper, glue, ink or fine sand
- 6.1.3 Table or chair
- 6.1.4 Thread, stones of different masses, watch
- 6.1.5 Rubber band, stones of different masses, watch
- 6.1.6 Tin, paper, string
- 6.1.7 Water tank, etc
- 6.1.8 Ink or potassium manganate(VII) (permanganate), a plate, plastic bag
- 6.1.9 Piece of cork, light wood or polystyrene, dropper (see 6.1.8), plate
- 6.1.10 -
- 6.2.1 2 empty tins, string
- 6.2.2 2 pieces of metal
- 6.2.3 2 spoons, string
- 6.2.4 Table
- 6.2.5 Some metres of a thin wire, two poles
- 6.2.6 Plastic bucket, 2 stones
- 6.3.1 Plate or tray, straight metal, plastic or wood barrier, rectangular block
- 6.3.2 Wall or door, 2 paper cones, a sheet of cardboard
- 6.3.3 A window with burglar bars, rope of about 5 m length, a stick
- 6.3.4 A garden hose pipe
- 6.3.5 Tall building or wall
- 6.3.6 Tall tin or jar, a clock, a sheet of cardboard
- 6.4.1 A soft board, thread, 2 pencils, various stones
- 6.4.2 4 equal soft drink bottles
- 6.4.3 A wooden block (better: a box), bicycle spokes
- 6.4.4 A bamboo tube (1.5 cm x 30 cm)
- 6.4.5 Empty tin with lid, wooden stick, string
- 6.4.6 Wooden box, timber bars of different wood and thickness, 2 sticks
- 7.1.1 Wooden blocks as stands, cardboard, candle
- 7.1.2 Manila sheet, string
- 7.1.3 Candle, pinhole camera (see 7.1.2)
- 7.1.4 Pencil, candle, white paper
- 7.1.5 2 candles, otherwise like 7.1.4
- 7.1.6 Glass bottle, damp paper etc., (torch), some cards
- 7.1.7 Comb, white paper, piece of cardboard
- 7.1.8 Torch, piece of card, piece of white card or paper as screen, pencil
- 7.2.1 2 plane mirrors, candle
- 7.2.2 Spherical spoon or concave mirror, white card, candle, sheet of white paper
- 7.2.3 Like 7.2.2 plus candle, sheet of white paper
- 7.2.4 Spherical spoon or convex mirror, candle, white paper, needle
- 7.2.5 Transparent glass-pane, candle, bottle
- 7.2.6 2 mirrors, rectangular box
- 7.2.7 Paper, plane mirror
- 7.3.1 Coin, lid of a jam jar
- 7.3.2 Transparent bottle, coin
- 7.3.3 Glass or jam jar, pencil
- 7.3.4 Pin or needle, cork, glass or jam jar
- 7.3.5 -
- 7.3.6 -
- 7.4.1 Convex lens or opened bulb (see p. 110), paper
- 7.4.2 Concave lens or soda bottle bottom or wire loop of 8-10 mm diameter
- 7.4.3 Manila sheet, opened bulb (see p. 110) or convex lens, parchment paper
- 7.4.4 Simple box camera (see 7.4.3), window or candle
- 7.4.5 -
- 7.4.6 Thin wire or opened bulb (see p. 110)
- 7.4.7 Wooden box, metal strip, plane mirror, thin wire loop of 3 mm diameter
- 7.4.8 Box camera (see p.90), plane mirror, parchment paper
- 7.4.9 Large sheet of paper
- 7.4.10 Box camera (see p.90), convex lens
- 7.4.11 Box camera (see p.90), concave lens

- 7.4.12 Some paper
- 7.5.1 Glass prism, white paper as screen, second glass prism or convex lens
- 7.5.2 Plane mirror, dish, white paper as screen
- 7.5.3 Hose pipe
- 7.5.4 White card, blue, green and red pencils or felt pens, string
- 8.1.1 Magnet (e.g. from discarded loudspeaker) plus materials listed on p.98
- 8.1.2 Magnet, magnetised steel needle (see 8.1.3), thread
- 8.1.3 Needle, magnet
- 8.1.4 Needle, magnetised pin or needle (see 8.1.3), paper, small pieces of wood or cork
- 8.1.5 Bicycle spoke, thin insulated copper wire (from old motor coil), 3 radio batteries, insulated wire, iron filings or bits of steel wool
- 8.1.6 The same as in 8.1.5 plus burner
- 8.1.7 Paper, bar magnet or magnetised steel needle, iron filings or bits of steel wool
- 8.1.8 Magnetised knitting needle (see 8.1.3), thread
- 8.1.9 Wooden pin, bowl, magnetised razor blade
- 8.1.10 Metal rod or needle, 2 magnetised needles or steel nails, thread
- 8.2.1 Plastic pen, piece of paper
- 8.2.2 2 plastic pens, thread, glass bottle, silk (e.g. baibui) or polyester material
- 8.2.3 Polythene sheets from transparent covering of a cigarette package or a plastic bag, piece of wood
- 8.2.4 Small piece of aluminium foil, cotton thread, plastic ruler or pen
- 8.2.5 Tap with water, plastic pen, woolen cloth
- 8.2.6 Balloon, wooden or synthetic cloth
- 8.3.1 2 radio cells, torch bulb, connecting wires, 2 metal strips, clothes-peg, plus materials listed on p. 104
- 8.3.2 Torch bulb, 8 metal strips, 3 radio cells, insulated wire for connecting
- 8.3.3 2 radio cells, 2 bulbs, 2 bulbholders (see 8.3.1), switch (see 8.3.2), insulated wire
- 8.3.4 2 radio cells, bulb holder (see 8.3.1), switch (see 8.3.2), insulated wire
- 8.3.5 2 radio cells, bulb, bulb holder, resistance wire or long wire from steel wool, insulated wire for connections
- 8.3.6 4 radio cells, insulated wire, torch bulb, cell holder, bulb holder
- 8.3.7 Styrofoam, 8 cm steel wire (from steel wool), insulated wires, 4 radio cells, some pieces of wood
- 8.3.8 3 radio cells, very thin steel wire (from steel wool), torch bulb, switch, insulated wire, piece of wood
- 8.3.9 2 radio cells, bulb, bare copper wire, insulated wire, switch, salt
- 8.3.10 3 radio cells, switch, 1-2 mm copper wire, insulated wire, needle, thread
- 8.3.11 3 radio cells, switch (see 8.3.2), insulated wire, thin insulated wire (e.g. from a motor coil)
- 8.3.12 4 radio cells, switch, insulated wire, 2 magnets or U-magnet, wooden stand for the magnets
- 8.3.13 Worn out radio cell
- 8.3.14 Bicycle with dynamo and headlight

# Questionnaire

## Questionnaire About "Sourcebook for Teaching Physics to Beginners with Locally Available Materials"

(Please tick the relevant answers)

Teacher  O'Level student

Other occupation .....

Male  Female  Domicile village  Town

Country .....

I have used the Sourcebook for private studies   
in my occupation

I like .....

I dislike .....

The book helped me .....

I think the following parts should be omitted  
.....  
.....

I would like to see the following topics added to the book when a new edition is made  
.....  
.....

Further comments: .....

Please send to: **Mzumbe Book Project,  
P.O. Box 19 Mzumbe,  
Morogoro - Tanzania.**



This book .....

- emphasizes learning Physics by doing without which no scientific development can take place.
- describes how to make a Physics Kit which is a minilab by itself. It can be used to equip schools which lack laboratory equipment for Physics with locally available materials.
- Students can even make their own Physics Kit and use it as a home lab to promote their talents in Physics.
- promotes creativity and shows that creative Physics lessons can take place in any scientific development.
- tries to make teachers and students aware of the resources available in their environment which may be used for the teaching and learning of Physics and other science subjects.

ISBN 9987 552 11 0

Low priced edition

**Mzumbe Book Project**  
**P.O. Box 19 MZUMBE, MOROGORO - TANZANIA**



**Sponsored by:**  
**Canadian Organization for Development through Education**