

**Some characteristic comparing details of various crossflow radial MINI-HYDRO turbines**  
*- translation -*

One of our readers has asked our editing office to assess consideration his on an article published in No. 3 (1993) in the column „We transfer“ and relates to the turbine CINK. The reader asked us not to publish his name. The author of the comments on the article, Mr. Krešimir Franjiè is interested in clearing up the matter. We enclose the reader's letter (the original information is known to the editors) and an assessment with the comments of Mr. Franjiè.

The reader's letter:

I am writing about the contribution in the column „We transfer“ describing the CINK turbine. Unfortunately the schematic figure is obsolete and the note saying the turbine is a good aerator is not true. If negative pressure greater than 2,5 to 3 meters water column is created in the diffuser (5), the cavitation bubbles will act in the zone of the blades. Catastrophic consequences result as combined chemical and mechanical abrasion of the blades follows.

It is written in the introduction that this is an improved Banki turbine in spite of the fact that 20 years ago (around 1932) a patent was asked for by an Italian company.

The scheme of the CINK turbine originally drawn by an Australian engineer A. MICHELL was not patented. The turbine that he patented in 1922 is exhibited in Deutschen Museum in Munich as a model for more than 40 years. An improved Michell turbine has been investigated by OSSBERGER, the first ones have been built as early as 1949 and the results have been published in 1952. (L.A.Haimerl: Durchströmturbinen, Deutsche Müllerzeitung 1956 volumes 14 - 17.)

The Ossberger turbine is being made in Weissenburg in Bavaria. It follows from the scheme that the negative suction pressure is limited by spring operated air valve.

So much the reader.

***The historical development of the crossflow radial turbine***

The theoretical basis of this turbine was published by Poncelet in the past century. The basis of his theoretical considerations was a simple water wheel with horizontal shaft. The practical outcome of his consideration was developed by a ingenious Australian engineer A.S.Michell who patented his machine in 1903.

Further development of this machine by a long research in Germany was made by a Hungarian engineer D. Banki (1912 - 1919). This development was patented in 1917. At this time the turbine was known as Michell-Banki turbine.

A cooperation between Michell and a Bavarian businessman Fritz Ossberger who owned a factory in Thalmassing near Nurnberg started in early twenties. This resulted in a patent of a free stream turbine in the year 1922. Further development led to a patent denominated as crossflow turbine issued in 1933. This turbine is called Michell-Ossberger turbine in the literature since that time. By success on the market the capital was created to built new factory in Weissenburg, where present management has its seat. Up to date this turbine is manufactured and installed at more than 8000 sites. At the time being the turbine is called turbine Ossberger.

After a longer pause in the development of this type of turbine a patent by a Czech engineer Miroslav Cink introduces a further development of the crossflow radial turbine. The production destined for market starts in cooperation with Czech companies in 1985. Since 1992 the turbine is manufactured in a private factory CINK-MVE in Carlsbad. More than 150 turbines have been manufactured and put into operation till now.

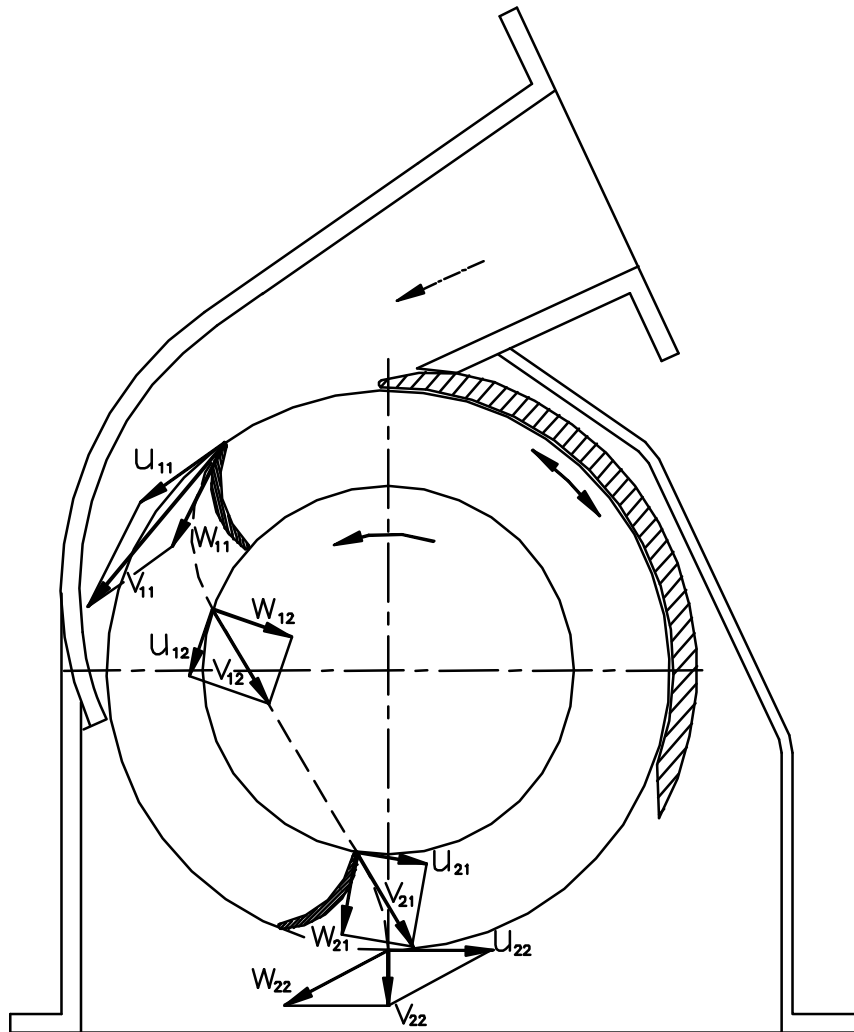

**Fig. 1**

***A popular explanation of the theoretical principles***

The theory of a crossflow radial turbine on the basis of a modified water wheel was formed by Poncelet on the basis of the general Euler turbine theory.

An example of crossflow through the radial wheel according to the mentioned theory is presented in Fig. 1. The specific energy change in the first part of the crossflow gives:

$$Y_{rt1} = u_{11} v_{11u} - u_{12} v_{12u}$$

and in the second part

$$Y_{rt2} = u_{21} v_{21u} - u_{22} v_{22u} ,$$

the total change in the wheel being

$$Y_{rt} = Y_{rt1} + Y_{rt2} .$$

The maximum change of energy is reached when

$$v_{12u} = v_{22u} = 0 \ (\alpha_{12} = \alpha_{22} = 90^\circ).$$

This point is called nominal working point or the point of maximum degree of effect.

In this case the overall change of energy in the wheel (at the same time the maximum possible in the given conditions) is

$$(Y_{rt})_{\max} = U_{11} V_{11u} - U_{21} V_{21u} .$$

The velocity vectors at inflow and outflow from the individual crosssections of the wheel follow from the laws of the vector algebra. In case of flow through the profile cascade of the wheel it means that absolute velocity ( $v$ ) is a vector sum of the circumferential velocity ( $u$ ) and the relative velocity ( $w$ ).

If we take half of the vector parallelogram only (which is sufficient for understanding) a so called velocity vector triangle is formed. The velocity triangles for the nominal working point are shown in Fig. 2.

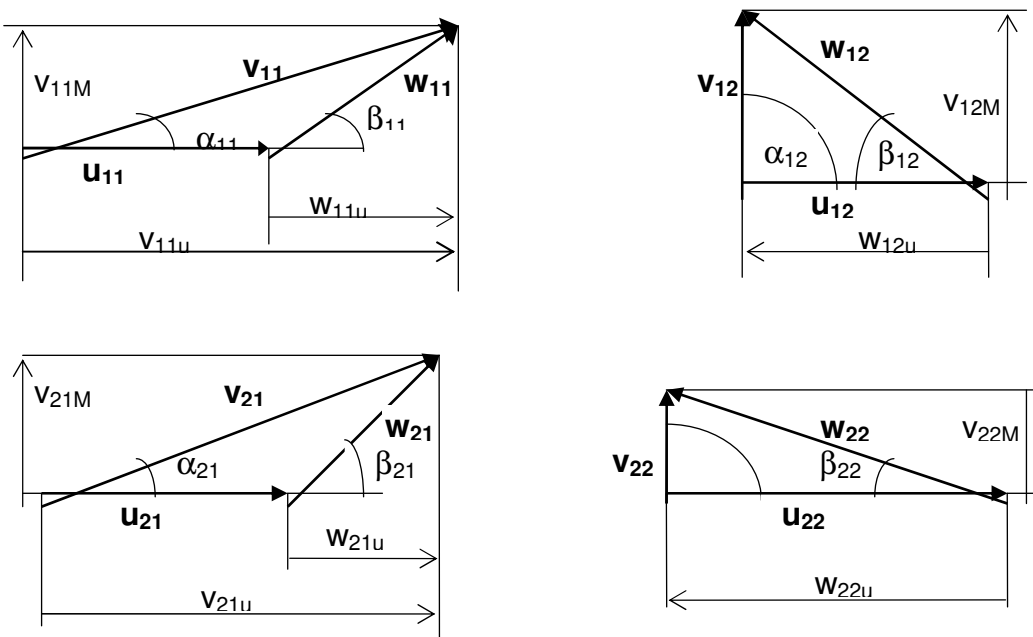
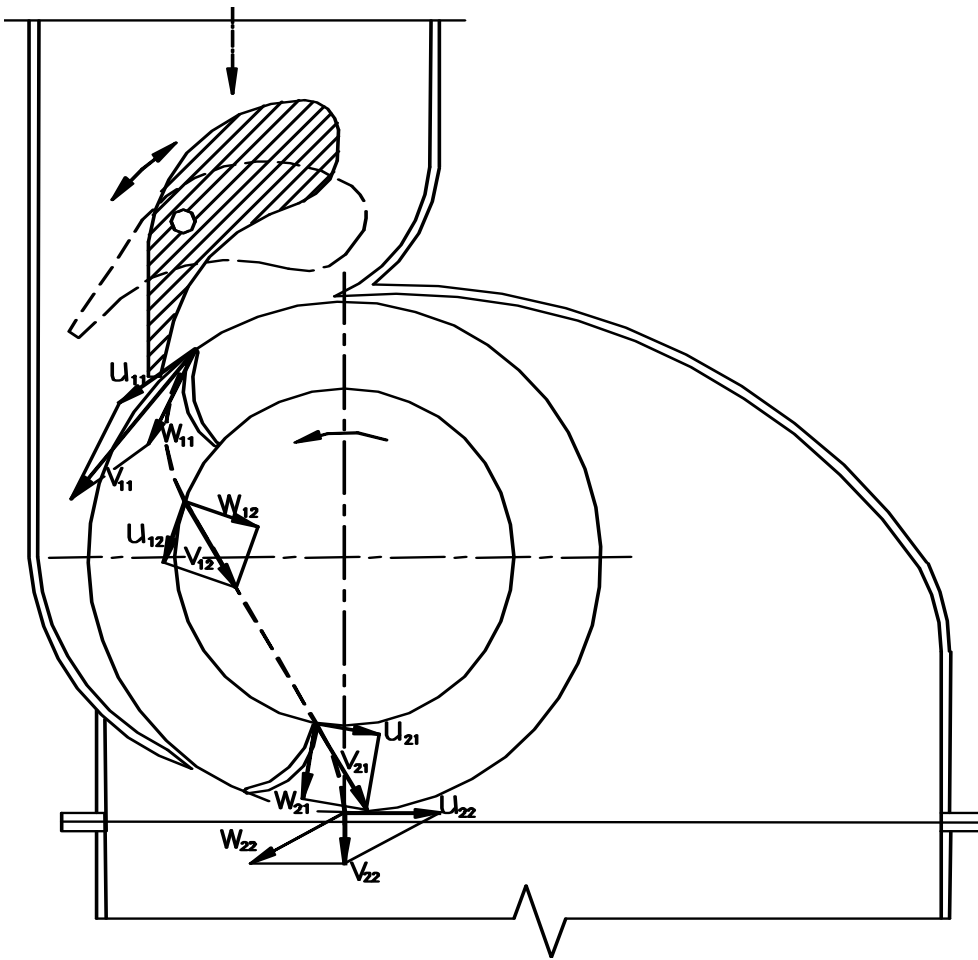

**Fig. 2**

The foregoing consideration on the change of energy are illustrated by velocity triangles as a product of the lengths of the circumferential velocity vector ( $u$ ) and the projection of the absolute velocity ( $v_u$ ) vector into the direction of the circumferential velocity during the two passages across the wheel cascade. The triangles also enable to follow the changes caused by flow alterations in the turbine; this can be used to prove the differences between the individual turbines. If the turbine losses and the suction bell or diffuser effects are neglected, the power generated by the turbine is

$$P \sim \rho Y_{rt} Q$$

and can be changed by the rate of flow only (according to the needs of the grid in case of big hydros or to the natural rate of flow in case of small hydros)



**Fig. 3**

The rate of flow into the turbine may be changed by various methods: a simple valve or segment (Banki), hydraulic flap (Ossberger) or profile shaped semicircular segment (Cink). In the following part an analysis of this turbine will be made from the point of view of flow regulation possibilities and consequences of this regulation as principal features of the turbine.

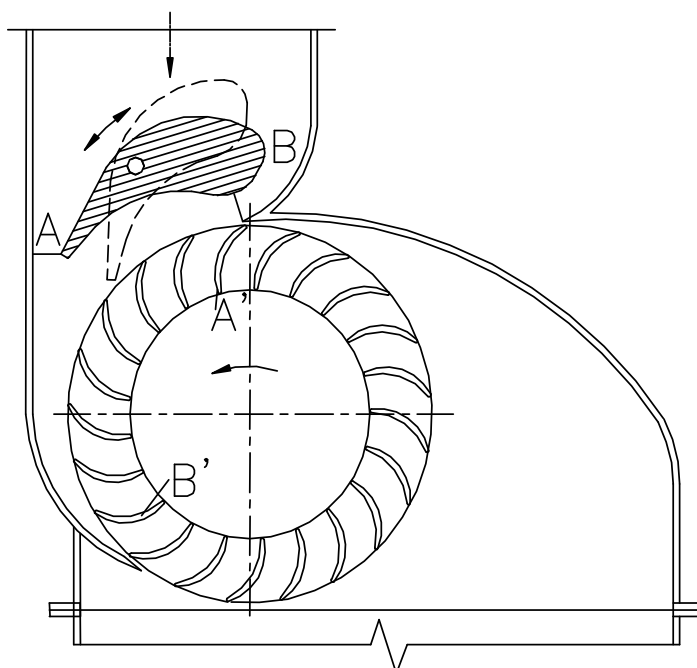
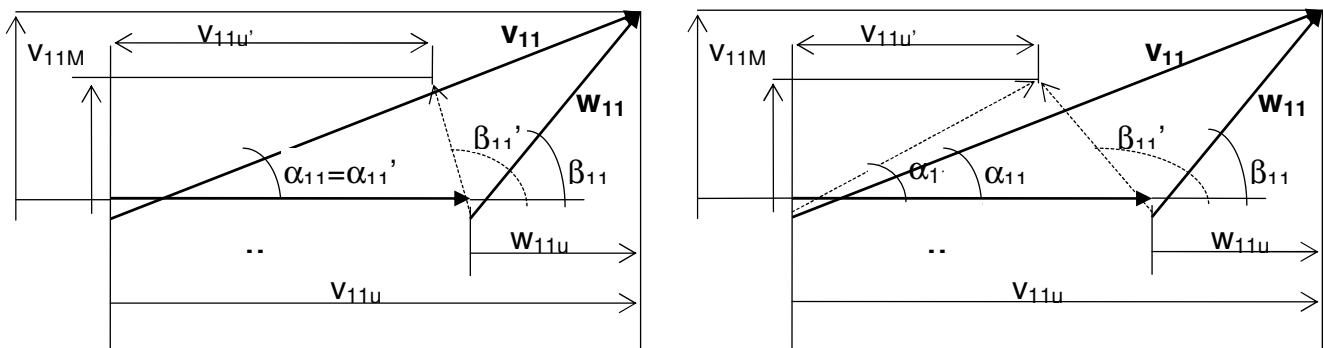

**Fig. 4****Analysis of the hydrodynamic possibilities of the various types of crossflow radial turbines**

The flow into the Cink turbine wheel is shown in Fig. 1.

The Fig. 3 illustrates the flow into Ossberger turbine wheel. Comparing the figures for nominal point of operation shows no difference. This is the reason why both mentioned turbines reach the same efficiency in this point (when the effects of suction bell at Ossberger or diffuser at Cink are neglected).

In case of the necessity to diminish the flow (grid demand or natural flow decrease) the Cink turbine must have the segment gradually closed. In this case the inflow cross-section is smaller but the triangle of velocities remains unchanged.

**Fig. 5**

In case of the Ossberger turbine the inflow is changed by turning the flap (Fig. 4) whereby the inflow cross-sections are changed (denominated A and B in Fig. 4). Turning the flap changes flow conditions in the cascade in the zone limited by blades A' and B'.

On the blades A' and B' the absolute velocity vector direction remains unchanged being formed by the walls of the casing ( $\alpha_{11} = \alpha_{11}'$ ). The consequences may be seen in the left velocity vector triangle in Fig. 5. The flow decrease leads to diminishing both the meridional component  $v_{11M}$  and the circumferential component  $v_{11u}$ . The circumferential component  $u_{11}$  should remain unchanged because of the generator's constant RPM. It should be noted that the flow change causes a change of the angle  $\beta_{11}'$ , i.e. the blade angle of attack.

The blades remaining between A' and B' suffer from a change of the absolute velocity vector direction ( $\alpha_{11} \neq \alpha_{11}'$ ) being different for each of them. The state can be generally described by the right velocity vector triangle in Fig. 5; the change of  $\beta_{11}'$  is still greater.

On both mentioned pictures the triangles corresponding to the nominal point are shown in full lines, the triangles corresponding to low rate of flow by dotted lines. The changes of the angle of attack  $\beta_{11}'$  are evident, caused by the absolute velocity component changes. If the runner blades were designed and made to suit the flow in the nominal point with the corresponding angle  $\beta_{11}$ , any deviation from this direction is unfavourable from the point of view of hydraulics. This causes rapid decline of efficiency at very small rate of flow changes from the nominal point value.

The facts described explain the reasons of the sudden efficiency drop of the active inflow to the Ossberger turbine. Ossberger was therefore forced to introduce two inflow sections (with flow rate ratio 1:2) with a partial flow along the runner (and two independent regulation flaps) to be able to create acceptable turbine efficiency values in a wide range of flow rate.

If we assess the Cink turbine now, the originality and geniality of introducing the profiled segment for regulation is evident. The first passage velocity triangle is constant (with the exception of extremely low rates of flow, when the segment gap is the same or lower than the blade pitch) and optimal. The change of the efficiency value in case of very small rates of flow is due to the change of velocity triangles of the second passage; this is a problem the size of which precludes describing it in one short article.

To arrive at a picture valid for the Banki turbine in the described conditions of operation, it is necessary to say that the changes of flow due to a simple valve can be described by the right triangles of Fig. 5; the conclusion connected with these triangles are applicable to the Banki turbine, too.

### ***The remaining differences***

The Banki turbine was of the action type i.e. the pressure in the casing was atmospheric. It had to be placed rather high above the lower water level to prevent the blades from touching it. A rather great loss of geodetic head resulted, significant in case of low heads typical for most installations.

Michell and Ossberger solved the problem by introducing a tube for underpressure in the casing making the turbine independent from lower water level variations. To achieve this an underpressure limiting spring operated air valve had to be installed in the casing.

A constant section draft tube did not enable the full use of the outlet water velocity denominated  $v_{22}$  on Fig. 2; such is approximately the velocity in the draft tube. Its value is usually between 2,5 and 3,5 m/s. If the mean value of 3 m/s is taken into account, the corresponding velocity head is

$$h_v = \frac{v^2}{2g} = \frac{3^2}{2g} = 0,459 \text{ m.}$$

This head is taken away from geodetic head, i.e. is not used for power generation. For instance in case of a geodetic head equal to 3 m, a loss of 15,3 percent (i.e. 0,459 m) from the energy at hand results. This makes the Ossberger turbine very uneconomical at low heads.

Cink modified the draft tube into the shape of a diffuser increasing the section in the downward direction. By making use of the diffuser effect most of the runner outlet energy could be used. Modifying the above mentioned example to diffuser outlet speed of 1 m/s the outlet loss is reduced to 0,051 m making it 1,7 percent of the geodetic head.

By this way the Cink turbine got acceptable even for extremely low head installations which is its great advantage over all known turbine types.

Using the diffuser effect the overall turbine efficiency in the nominal point is improved by about 3 to 5 percent (dependent of head). This gives the Cink turbine a corresponding lead over the Ossberger type.

### ***Conclusion***

Returning to the reader's notes mentioned at the beginning the following may be concluded:

- 1) The reader follows the technical literature closely. He connects the drawing from [4a] made by the author for the item Water Turbines in Technical Encyclopaedia) with the Michell's drawings

from 1904. If this idea is true, it would mean a jump over 90 years of development of this type of turbine (Banki, Ossberger, Cink). Michell would surely consider the last solution to be the best. We can hope that this article will help our reader to clear up the problems. If he wishes to widen his knowledge even more the author of this article is at his disposal.

- 2) Further the meaning of cavitation (chemical and mechanical abrasion) is not quite clear to the reader. The cavitation is caused by water vapour forming in extreme underpressures. The causes of the underpressure are the geodetic placing of the point in question (e.g. high above the lower water level) and the fluid velocity.

Because of relatively low velocities at the second water passage through the runner and at the outlet from the runner it is possible to use a relatively strong underpressure in the turbine casing (high turbine position above lower water level). Further factors enter in practice like atmospheric pressure, water temperature, velocity increase on the suction surface of blades; for safety reasons the casing underpressure is limited. For example the Cink company has installed the turbine in a water supply system Kružberk so high that the casing underpressure reached a value 6,2 meters of water column. The turbine maintains a record of many years reliable operation.

In spite of that, if possible, Cink company doesn't recommend to exceed the height 3,5 m above tailwater level.

The cavitation erosion as a consequence of cavitation sets is only in the conditions of extreme lower water levels. Then the underpressure limiting valve is used.

- 3) The author of this article had not the opportunity to inspect the turbine exposed in Deutchen Museum in Munich; on the base of the historical development he assumes it to be the „historical“ Michell - Ossberger turbine from 1933. This might be the case because the Germans as a technical nation have no representant among the water turbine inventors (Pelton, Francis and Deriaz were Americans, Kaplan was a Czech and Banki was a Hungarian).

- 4) As far as the function of the underpressure valve on the casing of Ossberger turbine is concerned the reader is again not right. This valve as explained maintains only an optimal value of underpressure; it is installed for individual case and geodetic head.

As described this valve lets through an amount of air inside the casing which is exactly necessary to maintain the pre-set value of underpressure bypassing the influence of the lower water level.

The air sucked into the Cink turbine is regularly distributed and mixed with the water leaving the runner serving a double purpose. First it damps the pressure pulsation which may arise in the diffuser (a phenomenon known with Francis and Kaplan turbines, too). Second purpose is ecological, i.e. the aeration (oxygenation) of the polluted water in the stream.

Then without respect to the reason of air suction the turbine serves as a good aerator. The reader should not be exclusive in his conclusions; it seems he is not well informed in the matter.

The mentioned advantages of the turbine patented by Czech Ing. Cink make the turbine original and different from the foregoing types (Michell-Banki and Michell-Ossberger). The author feels right to use the term CINK turbine as it is evident that the turbine is going to be known under this name in technical history. There is also another reason: The name of the inventor should not get lost as it happened with the name Michell.

#### **Literature:**

- [1] S. Khosrowpanah, M. L. Albertson, A. A. Fiazat: *Historical overview of crossflow turbine*, Water Power & Dam Construction, October 1984, 38 - 43
- [2] K. Franjiè: *Novi tip turbine za male hidroelektrarne*, Energetika \* Gospodarstvo \* Ekologija \* Etika - EGE, ožujak 1994, 36 - 38
- [3] *Ossberger company prospects*
- [4] M. Cink: *Použití vodních turbín Cink, system Bankieve vodarenství*, SOVAK, kveten 1993, 15 - 16

- [4a] M. Cink: *Korištenje vodnih turbina tipa Cink u vodovodnim sustavima* (djelomičan prijevod (L4)) Hrvatske vode, studeni 1993, 216 - 217

Mr. Krešimir Franjić