

EUROPEAN
AIR WAR™

PILOT'S GUIDE

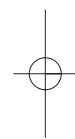

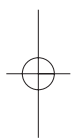
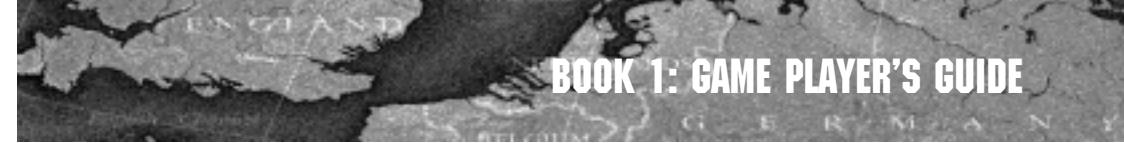
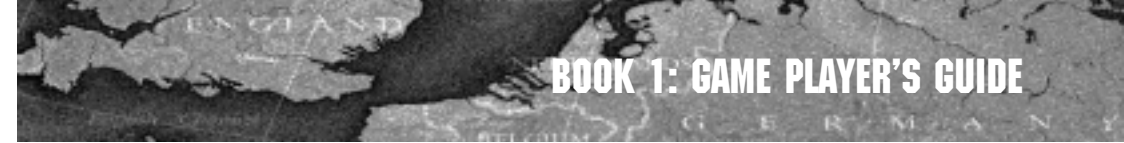

TABLE OF CONTENTS

- BOOK 1: GAME PLAYERS' GUIDE**viii
- REQUIREMENTS AND INSTALLATION**1
 - The Technical Prerequisites2
 - Installing the Game3
- THE CONTROLS**5
 - Configuration6
 - DIFFICULTY6
 - CONTROL11
 - GRAPHICS12
 - SOUND12
 - Keyboard13
 - PAUSING14
 - QUITTING14
 - Mouse14
 - Joystick15
 - Pedals16
- THE MAIN MENU**17
- QUICK START**21
- FLYING A SINGLE MISSION**23
 - The Hangar24
 - Mission Parameters25
 - TIME PERIOD25
 - TIME OF DAY25
 - WEATHER26
 - INSTANT ACTION26
 - MISSION TYPE27
 - TARGET28
 - NUMBER OF AIRCRAFT28
 - CRUISE ALTITUDE28
 - HOME BASE28
 - FRIENDLY SUPPORT ACTIVITY: SECONDARY AIRCRAFT29
 - FORMATION SIZE30
 - PILOT SKILL LEVEL30

- EXPECTED ENEMY ACTIVITY: ACTIVITY LEVEL30
- PRIMARY AIRCRAFT30
- SECONDARY AIRCRAFT30
- AAA ACTIVITY LEVEL31
- SAVING A MISSION31
- LOADING A MISSION31
- MAKING REVISIONS32
- Armaments Board**32
- Fly Mission**33
- Take-off**34
- Getting There**35
- The Cockpit Controls**36
 - MISSION MAP36
 - COCKPIT RADIO37
 - AUTOPILOT40
- Viewpoint and the Camera**40
 - F-KEY VIEWS41
 - SNAP VIEWS42
 - CHANGING PLANES42
 - TARGETING42
 - VIRTUAL COCKPIT MODE43
 - PADLOCK44
 - THE EXTERNAL CAMERA44
- Accelerating Time**47
- Encountering the Enemy**47
 - IDENTIFICATION47
 - GROUND TARGETS48
 - CYCLING YOUR GUNS48
 - DOGFIGHTING49
 - PADLOCK AND TARGETING FEATURES49
 - DIVE BOMBING50
 - STRAFING51
 - FIRING ROCKETS53
- Getting Shot Down**53
- Returning and Landing**53
- Debriefing**55



CAREER PILOT	57
Creating a Pilot	58
Loading a Career	60
The Briefing Room	61
The Hangar	62
ARMAMENT BOARD	62
FLY MISSION	62
The Aerial Campaign	63
BATTLE LINES	63
CHANGING BASES	63
REPAIRS AND REPLACEMENTS	64
PILOT FATIGUE	64
COCKPIT RADIO	64
RESCUE, CAPTURE, AND DEATH	64
Debriefing	65
Medals and Promotions	65
Barracks	66
LOGBOOK	66
VIEW MEDALS	67
RADIO	67
LEAVE	67
BUNK	67
Tour of Duty	67
Squadron Commander's Office	68
SQUADRON BOARD	68
The End of the War	69
Hall of Fame	70
MULTI-PLAYER MISSIONS	71
Connecting	72
IPX	73
TCP/IP	73
MODEM	73
SERIAL	74
Joining a Mission	74
Hosting a Mission	75
Session Parameters	75

Flying a Multi-Player Mission	77
COMMUNICATIONS	77
DEATH DURING TOTAL MAYHEM	77
PLAYER KILLS	78
The End of the Game	78
Newsreel	79
View Objects	79

BOOK 2: PILOT'S HANDBOOK

WHY YOU'RE HERE	83
THEORIES	84
THE COMBATANTS	85
The Battle of Britain	92
THE FALL OF FRANCE	92
ENGLAND STANDS ALONE	94
CHANNEL RAIDS	96
THE CALM BEFORE THE STORM	98
THE STORM BREAKS	99
ADLERTAG	101
THE BATTLE CONTINUES	106
LONDON	109
THE CRISIS	111
Fortress without a Roof	113
THESE MAD AMERICANS	113
SCHWEINFURT/REGENSBURG	116
OPERATION ARGUMENT	120
BIG "B", MARCH 6, 1944	122
PREPARING FOR INVASION	126
SUPPORTING THE INVASION	129
OPERATION BODENPLATTE	130
THE FALL OF THE THIRD REICH	132
Conclusion	133
AREA BOMBING	133
STRATEGIC BOMBING	133
THE INTERDICTION CAMPAIGN	134

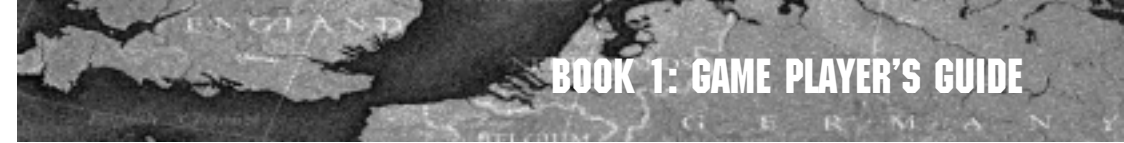

FLIGHT SCHOOL	135
The Basics	136
ESSENTIAL AERODYNAMICS	136
LEVEL FLIGHT	142
ACCELERATION AND DECELERATION	142
LEVEL CLIMB AND LEVEL DESCENT (RISING AND FALLING)	143
CLIMBS AND DIVES	143
SIMPLE TURNS (BANKING)	145
FINAL ADVICE	145
Instruments	146
COMPASS	147
ARTIFICIAL HORIZON	147
AIRSPEED INDICATOR	147
TACHOMETER	148
ALTIMETER	148
OIL PRESSURE GAUGE	148
ENGINE TEMPERATURE GAUGE	149
FUEL GAUGE	149
MANIFOLD PRESSURE GAUGE	150
RATE OF CLIMB INDICATOR	150
AMMUNITION COUNTER	151
Formations	151
ECHELON	151
V	152
FINGER FOUR	152
BOMBERS AND ESCORTS	153
Simple Maneuvers	154
AILERON ROLL	154
BARREL ROLL	155
LOOP OVER	155
LOOP UNDER	156
WING OVER	157
Emergency Procedures	158
RECOVERING FROM A STALL	159
THE POWER STALL	160
GETTING OUT OF A SPIN	163
LOW FUEL	164
DAMAGE	166
COMING IN ON A WING AND A PRAYER	167
FIRE	168

BAILING OUT	169
Advanced Flight	171
A LITTLE AIR COMBAT THEORY	171
YOUR WEAPONS	179
APPROACH	185
DOGFIGHT VS. HIT-AND-RUN	186
IMMELMANN	187
SPLIT-S	188
INTENTIONAL STALL	189
SKID	190
SLIP	190
SCISSORS	191
THACH WEAVE	192
ADVANCED MANEUVERING	194
Some Further Advice	200
TACTICAL QUICKIES	200
ALTERNATIVE DELIVERY TECHNIQUES	202
LANDINGS	210
THE COCKPITS	217
Background	218
United States Army Air Force	219
LOCKHEED P-38 LIGHTNING	220
REPUBLIC P-47 THUNDERBOLT	222
NORTH AMERICAN P-51 MUSTANG	224
Royal Air Force	226
HAWKER HURRICANE	227
HAWKER TEMPEST V	229
HAWKER TYPHOON Mk IB	231
SUPERMARINE SPITFIRE	233
Luftwaffe	235
Focke Wulf Fw 190	236
MESSERSCHMITT Bf 109 (Me 109)	239
MESSERSCHMITT Me 110 (DESTROYER)	242
MESSERSCHMITT Me 262A	244
GLOSSARY OF TERMS AND ACRONYMS	246
CREDITS	253

An aerial photograph of a city, likely Rotterdam, showing extensive destruction of buildings and infrastructure. A semi-transparent map of Europe is overlaid on the left side of the image, with labels for 'North Sea', 'NETHERLANDS', 'BELGIUM', 'LUXEMBOURG', 'GERMANY', 'FRANCE', 'CZECH REPUBLIC', 'SWITZERLAND', 'AUSTRIA', and 'POLAND'. The map labels are in a light, sans-serif font. The city below is in black and white, with smoke rising from several points, suggesting a recent bombing or fire.

BOOK 1: GAME PLAYER'S GUIDE

Great Britain and France declared war on Germany in early September of 1939, a mere two days after Germany had invaded Poland. Less than a year later, France would be occupied and England fighting for her own independence. Thus began the European campaign of the Second World War. The conflict flared on ground and at sea, bloody and hard-fought, but it would be in the air that the war was won.

Most of the fighting over Europe was too high for people down below to see. The sole signs of the melee overhead were the distant buzz of engines and the occasional wreck, yet battle was no less fierce in the air than on the ground. With only a thin skin of metal as a shield, pilots had little room for error. Their fate was in their own hands. Success was, of course, only fleeting—failure often final.

From the Battle of Britain in the summer months of 1940 until the day of Axis capitulation five years later, the world's military leaders engaged in a struggle for control of the skies over western Europe. Aerial support was key to any offensive assault and a principle means of defense as well. Crippling a nation was as simple as wearing down its supply of pilots and planes.

*In **European Air War**, you step into the cockpit of a 1940s' fighter plane and join your country's daily struggle to achieve air superiority. Germany is wearing away the RAF's resources. The Allies strive to beat back the onslaught and shove their way straight to Berlin. Now you assume your place in the pilot's seat.*

*This book, the **Game Player's Guide**, contains complete instructions on installing, running, configuring, and playing **European Air War The Pilot's Handbook** (later in this manual) has historical background and a little advice on piloting. The **Quick Reference Card** is a one-stop reference to all of the keyboard, mouse, joystick, and other controls. Changes made to the game after this manual was written are described in the **Readme** file; that file was written last, so any notations in it supersede all other information.*

REQUIREMENTS AND INSTALLATION

You've got the box open, the CD-ROM in your hands, your flight jacket on, and that manic gleam in your eyes. What do you do now?



THE TECHNICAL PREREQUISITES

For *European Air War* to work, there are a few things your computer *must* have.

- ☛ The processor has to be a 166 MHz Pentium or better. If you have a 3D graphics acceleration card, you can play on a 133 MHz Pentium.
- ☛ You must have at least 32 MB (megabytes) of RAM (working memory).
- ☛ You must have a CD-ROM drive.
- ☛ Since the installation program will copy parts of *European Air War* onto your hard disk, you must have a lot of empty storage space on your hard drive. How much you need depends on how much of the game you choose to install; the different amounts are calculated for you by the installation program, and it shows you what you need for each install type.
- ☛ Your computer must be capable of SVGA quality graphics.
- ☛ There must be a working mouse (or a device that fulfills the same function) attached to the computer.
- ☛ You must have DirectX version 6.0 (or higher). If you don't have this, you can install version 6.0 as part of the installation process. To use the game's 3Dfx Glide support, you must have Glide API version 2.43 (or higher) installed and working.

There are also a few pieces of equipment that we strongly recommend you have:

- ☛ To hear the game, you must have a sound card and the requisite drivers to support DirectSound.
- ☛ To fly well, we recommend you use a joystick. We encourage the use of throttle controls and foot pedals (for the rudder) if your joystick doesn't have that capability.
- ☛ For modem play, we recommend you use a modem capable of 28.8 kps or faster.

If you think you have all of these, but still have a problem running the game, please contact Technical Support for assistance.



INSTALLING THE GAME

Before you can play *European Air War*, the installation program must copy some files onto your hard disk. To have it do so, follow these instructions:

- ☛ Turn on your computer. Windows 95 should load the Microsoft CD-ROM Extension when the computer starts up. (If you have problems installing, this extension may not be loaded. Check your computer manuals for instructions on getting it loaded.)
- ☛ Open the CD-ROM drive, place the *European Air War* CD in it, and close the drive.
- ☛ *European Air War* is a Windows 95 "AutoPlay" CD-ROM. That means that just putting the disc in the drive for the first time starts up the installation program. If AutoPlay is enabled, an AutoPlay menu should appear. If AutoPlay is not enabled, double-click on the "My Computer" icon on your Win95/98 desktop. Next, double-click on your CD-ROM icon to install the game. If the AutoPlay menu still does not appear at this point, locate the "setup.exe" file on the *European Air War* game disc and double-click on it.
- ☛ Click on **Install** to continue. (If you change your mind at this point, click **Exit**.)
- ☛ As is usual in Windows 95 installation procedures, there are two decisions you need to make before the installation process can begin. The first decision is to what directory you want to install the game. You can accept the default, type in a directory path, or use the **Browse** button to seek out a directory. Click **OK** when you're done.
- ☛ The second decision is what sort of installation you want to do. Pick one of the options presented:

Typical installs the required program files and some other stuff. This type of installation strikes a balance between the needs of game speed (more files copied) versus conserving hard disk space (less files copied). [55 MB]

Compact is the minimum; it installs only the required program files. [2 MB]
Note: This install type risks slower game performance.

Custom gives you control of what gets installed. How much disk space this takes up depends on what you select. [#MB based on your selections]

Full installs everything for the best performance possible.



- ④ **European Air War** will now copy the files you selected to your hard drive from the CD-ROM.
- ④ Use the check-boxes to decide whether to add a shortcut on your desktop for this game and whether to begin the game immediately when the installation is done.
- ④ After the game itself has been copied over, **European Air War** will ask if you'd like to install Microsoft's DirectX drivers (version 6.0).

Once the installation is complete, the game is ready to play.

If you selected "Yes" when asked if you'd like to run **European Air War** now, the game begins right away. If you selected "No," you can still start playing now:

- ④ Leave the **European Air War** CD-ROM in the drive.
- ④ When the AutoPlay pop-up menu is visible, click the **EAW Play** button.

To play later:

- ④ Make sure that the **European Air War** CD-ROM is in its drive.
- ④ If you checked the shortcut box, double-click on the **European Air War** shortcut on your desktop. If you did not check the shortcut box, open the Windows® 95 **Start** menu, then select **Programs**, then **Infogrames Interactive**, then the **European Air War** sub-menu, and then select the **European Air War** option. You can also wait for the AutoPlay menu to pop up and then click the **Play EAW** button.

Have fun!

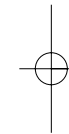
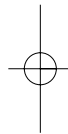

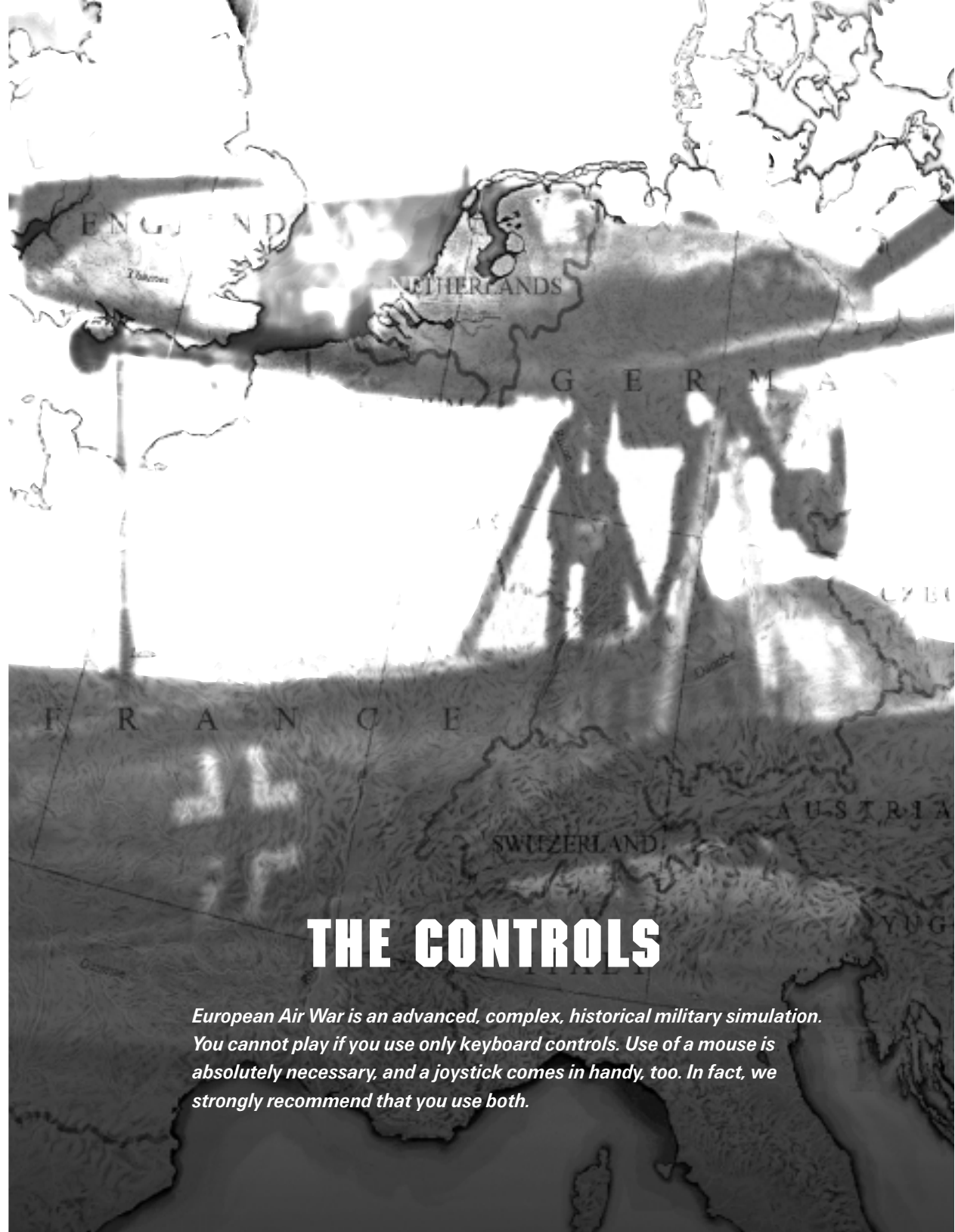

THE CONTROLS

European Air War is an advanced, complex, historical military simulation. You cannot play if you use only keyboard controls. Use of a mouse is absolutely necessary, and a joystick comes in handy, too. In fact, we strongly recommend that you use both.



What follows is a brief introduction to the use of the configurable game options and the standard game controllers. *European Air War* is designed to work with most of the available Windows 95 compatible flight simulation add-on hardware systems (“peripherals”). If you follow the installation instructions and the documentation that came with the peripheral you’re using, you should not have any problems. Customer Support will likely be able to solve whatever trouble you do encounter. Calibration settings for joysticks and other hardware is taken from Windows data; if you installed the hardware correctly, you should have no need to recalibrate just for this game.

CONFIGURATION

The first time you fire up *European Air War*, before you even consider stepping into the cockpit, you should click on the **Configure Game** button. Use the configuration setup to specify how you want to control the game, as well as to adjust the settings of such things as sound, screen resolution, and level of detail.

DIFFICULTY

These three menus—**Flight**, **Combat**, and **Display**—let you adjust the level of realism and difficulty of each mission you fly. As you enable more realistic settings, the overall Difficulty Rating increases, thus increasing your score at the end of every mission (a reward for playing at a harder level).

Flight

Flight Model Depending on your abilities and what you want out of this game, you can decide whether to use a **Realistic** flight model—with all the difficulty of piloting a real aircraft—or an **Easy** one, which is more forgiving.

Stalls/Spins This option, when enabled, makes it possible for your plane to stall (when your speed is below that needed to sustain lift) or go into a spin. Turn this option **Off**, and stalls and spins will not occur unless your plane has been damaged.



Torque Effect Radial engines create a turning force known as torque (see the *Pilot's Handbook* for details). Pilots of single-engine planes must take this into account. Twin-engine machines don't suffer the same pull, because their engines rotate in opposite directions and cancel the torque effect. If **Torque Effect** is **Off**, your plane will show no signs of pulling. However, when this is toggled **On**, single-engine aircraft will pull one side according to their manufacture. Torque has no effect when the autopilot is engaged, since the autopilot makes the necessary corrections.

Blackout\ Redout While designers can tinker with planes to make them react better at high acceleration, it's harder to enhance the human body's performance under similar conditions. High-speed maneuvers can prevent a pilot's heart from pumping enough blood into his brain. When an airman pulls hard out of a dive, turns his aircraft tightly at top speeds, or performs other high-speed aerial moves, he may lose consciousness—black out.

Forcing too much blood into the brain (as when throttling forward into a steep dive) is also a problem. If the pressure becomes too great, tiny blood vessels in the pilot's eyes burst. This is known as a “redout.” Severe brain damage or death can result.

Losing consciousness is especially dangerous at low altitudes, when you have too little time to recover, but even at great heights it poses serious risks. These days, pressurized suits help fighter pilots maintain control at high speeds. During World War II, such suits were too bulky and unpredictable to be practical, so pilots had to know their own limits.

If you enable blackouts, you subject yourself to the laws of nature and human limitations. If not, you'll maintain both vision and consciousness even when performing unheard-of aerial feats.



This pilot is at risk of blacking out.

Engine Overheat

Even when equipped with complex cooling systems, engines generate a lot of heat, and the harder they have to work, the more heat they put out. It's possible to damage an engine if you run it too hard for too long. In some planes, holding the throttle fully open for as few as ten seconds can lead to overheating, and overheating can quickly escalate into permanent engine damage—or complete failure. When **Engine Overheat** is disabled, you can run your craft all day without once approaching the danger point. If you opt for a more realistic scenario, beware a heavy hand on the throttle.

Structural Limits

Even the sturdiest and most dependable of planes has its limitations. When it's pushed beyond them, anything can happen, from the annoying—like buffeting in a dive—to the downright dangerous. A craft can fall into a spin or a stall, or a wing might break off in mid-flight and leave you plummeting helplessly back to the ground.

By selecting **On**, you open yourself up to many irksome but realistic problems that pilots of the day had to contend with. Leaving the option in the **Off** position, you avoid such troublesome issues and can push your plane beyond its physical limits.

Wind/Turbulence

When enabled, this option makes flying a bit harder, because wind can slow you down, adjust your course, and generally complicate things. Select **Off** if you do not wish to have your course deviate due to the effects of wind and turbulence.

Combat

Enemy Skill Level

This option provides a quick and easy way to modify the overall difficulty. You can choose between **Green** (to face inexperienced pilots), **Veteran** (pilots who have been in a few dogfights), and **Ace** (the most experienced the enemy has to offer). Be forewarned that the enemy skill level **Ace** is designed to push even the most fanatic flight simulation veterans to the limits of their abilities.

Landing

A combat pilot can count on very few certainties, but one thing is sure—what goes up must come down. Assuming that you haven't bailed out or showered down in a thousand pieces somewhere over Europe, you know that you're going to have to land your crate. How you do that depends on your plane and your piloting prowess. Some planes are easier than others to set down, but bringing one in for a successful landing always requires skill and an excellent knowledge of your machine. When you enable **Realistic**, you must cope with the vagaries of bringing your craft in manually. If you select **Simple**, touching down is a much simpler affair.

Realistic Gunnery

In actual air-to-air combat during World War II, it was no mean feat to hit your target. Pilots needed great skill and marksmanship (and sometimes luck) to down an enemy plane. Fortunately, in **European Air War** it doesn't have to be that difficult. Using a more blocky, less-than-precise silhouette of enemy aircraft to determine hits can turn many near misses into scores. Of course, if you'd rather have the greater challenge, that can be arranged, too. If **Realistic Gunnery** is off, you'll have a slightly easier time finding your mark. With the option on, hits on enemy aircraft are determined using a slimmer and more realistic silhouette.



Mid-Air Collision

The limited range of World War II weapons means that air-to-air combat takes place at close quarters. For your guns to be effective, you have to be frighteningly near your target. Mid-air collisions are of great concern; especially in the heat of battle, it's easy to lose track of who's around you and where exactly they are. This can be a fatal slip if **Mid-Air Collision** is enabled—aircraft coming into contact with each other explode in a fireball. With quick reflexes you might bail out, but at best you'll be headed for a dirt bath or a dousing. If you leave this option off, one aircraft can pass right through another without effect.

Unlimited Ammo

Ammunition is a valued commodity in aerial combat. Armed, you're a lethal threat, but when you run out of ammo, you must break off the attack and head home, vulnerable the entire flight. Every plane has weight and storage restrictions that limit how much ammunition the ground crews can pack on board. During the Second World War, a full load of bullets could be measured in seconds of firepower. In addition, most pilots had to estimate their remaining rounds without benefit of the ammunition counters now standard on warplanes. If you enter battle without **Unlimited Ammo**, be advised to use your weapons judiciously. If you opt instead for a limitless supply, just try not to give yourself away by the unrestrained use of your guns.

Invulnerable

This option allows you to designate whether or not your plane takes damage—from enemy fire, friendly fire, the ground, or anything else. If you want to practice flying without having to worry about damage, set this option **On**. When you're ready to fly in a real dogfight, turn this back **Off**. (Note that this option is always **Off** in multi-player missions.)

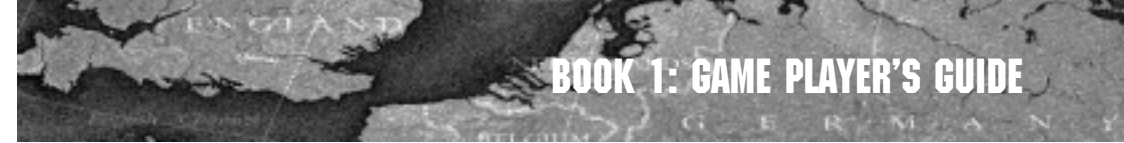

Display

Display Unit

This option controls what system of measurement is used by your commanding officers, your cockpit instruments, and your map. Select **English** to use the Imperial system or **Metric** for (oddly enough) the metric system. If you choose **Default**, each nationality uses the system they had in place at the time of the war.

HUD Display

You can use this to turn on the cockpit Head-Up Display, which is something no pilot during the war actually had. This projects useful information in front of you.

Altimeter Display

There are two types of altimeter. The type used during the war gives readings based on ambient air pressure. This is **ASL** (Above Sea Level). Modern radar altimeters read altitude **AGL** (Above Ground Level). During the war, planes did not use radar altimeters, and the description of the altimeter in this manual reflects that. If you choose to use **AGL**, that description no longer applies.

Airspeed Display

Select the way you want the Airspeed Indicator in your cockpit to work. **IAS** (Indicated Air Speed) measures your velocity relative to the air around you; this is the type of indicator used in WWII-era planes. **TAS** (True Air Speed) measures your actual rate of movement relative to the ground below you; this is more reliable for navigation, but less historically accurate.

CONTROL

This is where you designate exactly what hardware you'll use to control which aspects of the game—and exactly what controls correspond to which commands.

The *Flight Control* is the important one; it's the main instrument for flying your aircraft. Selections for the other options might change or be limited depending on what you select here. In general, for instance, you cannot use the same instrument as both *Flight Control* and for controlling the external camera—the exception being that if your joystick is your flight control, you can use the joystick "hat" to maneuver the camera.



To customize (or completely reconfigure) the controls for the game, select **Advanced**. This option gives you control over all four groups of controls—*View* controls, *Flight* controls, *Weapon* controls, and general *Game* controls.

When you're done, click **OK** to save your changes or **Cancel** to undo them.

GRAPHICS

The options on this screen influence how everything in every mission looks. Generally, more detail makes playing the game more realistic and fun, but it also tends to slow down the game's operation. If you notice that your plane doesn't respond as quickly as you would like, or that movements on the screen are jerky, you may need to lower the level of detail. Adjusting the settings to lower detail levels or turning some of the options off should result in a smoother picture and faster responses.

Make sure you select the correct **3D Renderer** option—the type of 3D acceleration you're using. You can also adjust your distance visibility. The higher the visibility, the farther you (and other pilots) can see.

If the background or the color level is darker than you would prefer, try sliding the **Gamma Correction** to the right to brighten the entire viewing area.

SOUND

The **Sound** screen lets you control not only the volume of game sounds but also their quality. Choose between 8-bit and 16-bit sound. The higher setting (16-bit) sounds better, but requires quite a bit more memory, as well. You can also determine the number of sound effect channels; generally, more channels means better quality, though you are limited by what your computer's capabilities.

You adjust the levels for the different sound effects and the music separately. Click anywhere along a line or drag the volume controls where you want them. Bear in mind that the engine sound effects can clue you in to the health of your plane—your engine may begin to labor before it actually fails. You can only react in time if you hear the change in pitch. You probably don't want to turn these sound effects completely off.

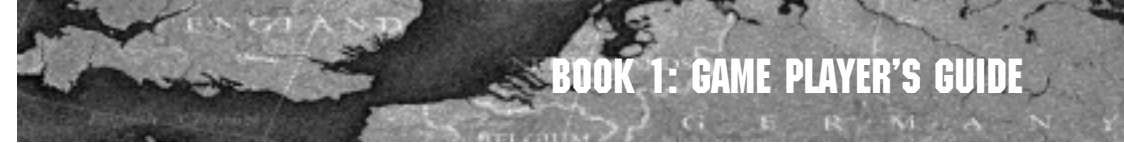

The last option in the sound configuration allows you to turn the subtitles on or off. The officer presenting your briefings speaks in the language of his homeland, as do all pilots on your radio. Thus, for example, if you are flying a German plane, but you do not understand German, you would turn this option on to have your briefing information and communications subtitled in your native language.

KEYBOARD

The keyboard is the primary control device for your computer, but it is often a secondary controller while playing *European Air War*. Keystroke commands are most commonly used to change the viewpoint while flying, to enter text in certain fields (naming pilots, for example), and to control things like the throttle, gear, and brakes.

Keyboard controls are represented in this manual by symbols. Thus, for example, Function Key # 1 would appear as **F1**, just as it does on the keyboard itself. Key combinations that should be pressed at the same time are separated by plus signs, as in **Ctrl+Alt+Del**. All keys will be capitalized, but you do not need to enter capital letters. (A capital **P**, for example, would appear as **Shift+P**, while a lowercase **p** would be **P**.) We use the standard abbreviations for the special keys.

Though some of the keyboard commands are described in the relevant sections, please refer to the **Quick Reference Card** for the exact default keystrokes used in controlling *European Air War*. You can change many of these defaults using the **Control** option on the **Configure Game** menu, described in **Configuration**.

Note that on most of the game screens (not during missions), you can use the **Spacebar** to toggle labeling of all the hot spots on and off. This can be quite helpful when you aren't sure exactly what you can do on a particular screen. You can also right-click to briefly view the hot spots; they stay visible as long as you hold down the **[RMB]**.

PAUSING

At any time while in flight, you can press **[Alt]+[P]** to pause the game. All action in the game will stop until you restart it, but you still have control of the external camera and the viewpoint controls. Note that none of the controls except those relevant to the camera and viewpoints will function while the game is paused. To restart the action, press **[Alt]+[P]** again.

QUITTING

The **Main** menu includes an **Exit** option for leaving the game, but real life doesn't always allow enough time to work your way back to this menu to quit. To leave *European Air War* at any time, you can press **[Alt]+[Q]**. The game prompts you to verify that you want to quit. Note that if you are in the middle of a career mission when you quit, your career continues with that mission when you come back to the game.

If you wish to end your current mission without shutting down the whole game, press **[Esc]**. You must verify this command. If you do, you proceed directly to your debriefing, and the mission is counted a failure unless you completed your objective before quitting.

MOUSE

If you do not have a joystick attached to your system, the mouse is likely to be the primary controller for *European Air War*. Even if you do have both a mouse and a joystick, the mouse is important. The mouse is necessary for selecting from menus and maps and moving around the briefing screens.

Mouse controls are represented in this manual in a manner similar to keyboard controls. Thus, for example, the Left Mouse Button would appear as LMB. Directional controls are represented by "mouse" commands in brackets—**[Mouse Left]**, for example.

Throughout this manual, we stick to the standard terms for using the mouse:

- 'Click' means to click the left mouse button (LMB).
- "Right-click" means to click the right mouse button (RMB).
- "Drag" means to hold down the LMB while you move the mouse.
- "Right-drag" should be obvious enough.
- "Double-click" means to click the LMB twice rapidly.

The mouse controls for the external camera are described in the relevant section. You can also use the *Quick Reference Card* as a quick reference. The mouse motions used to fly the plane are summarized here. You can change these defaults using the **Control** option on the **Configure Game** menu, described in **Configuration**.

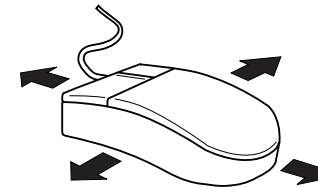

- [Mouse Fwd]** Stick forward, nose down (dive)
- [Mouse Back]** Stick back, nose up (climb)
- [Mouse Left]** Stick left, bank left (left turn)
- [Mouse Right]** Stick right, bank right (right turn)

JOYSTICK

If you have access to one, it's best to use a joystick as the primary control device for *European Air War*. Even in tandem with a mouse, the joystick is essential—a joystick is the optimum controller for the plane in flight.

Directional controls are represented in this manual by "stick" commands—**[Stick Left]**, for example. Joystick controls other than those for flight are described in the relevant sections. You can also use the *Quick Reference Card* as a quick reference. The default joystick controls used to fly the plane are standard and fairly obvious; they are summarized here. You can change some of these defaults using the **Control** option on the **Configure Game** menu, described in **Configuration**.



EUROPEAN AIR WAR

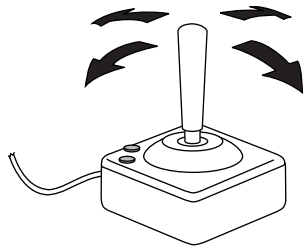

- [Stick Fwd] Elevators down, nose down (dive)
- [Stick Back] Elevators up, nose up (climb)
- [Stick Left] Bank left (left turn)
- [Stick Right] Bank right (right turn)
- [Button 1] Fire guns
- [Button 2] Fire Selected Weapon

PEDALS

Foot pedals are optional hardware for controlling the rudder of the plane. If you do not have rudder pedals, don't worry; *European Air War* also allows you to control the rudder from the keyboard, joystick, or mouse. Using rudder control, several useful maneuvers are available to you that are not possible using the stick alone.

Rudder pedal controls (rudder controls in general, in fact) are represented in this manual in bold type and enclosed in brackets. Thus, for example, sliding the left pedal forward and the right pedal back would appear as **[Rudder Left]**. The direction of the control (i.e. "left" or "right") is based on the direction in which the control motion moves the rudder, as is standard in aviation.

The rudder is the pilot's only direct method of controlling the yaw of the plane. (Please refer to 'Yaw' in the *Glossary* for a brief definition.) The primary uses of the rudder are to counteract the adverse yaw caused by banking with the ailerons and to steer the plane while on the runway. The rudder can also be helpful when you're making those little sideways adjustments as you approach the runway. The two pedal controls are as follows:

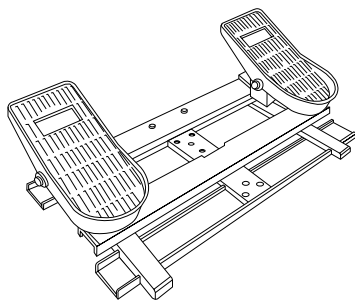

- [Rudder Left]** Yaw left (counteract adverse yaw of right bank)
- [Rudder Right]** Yaw right (counteract adverse yaw of left bank)

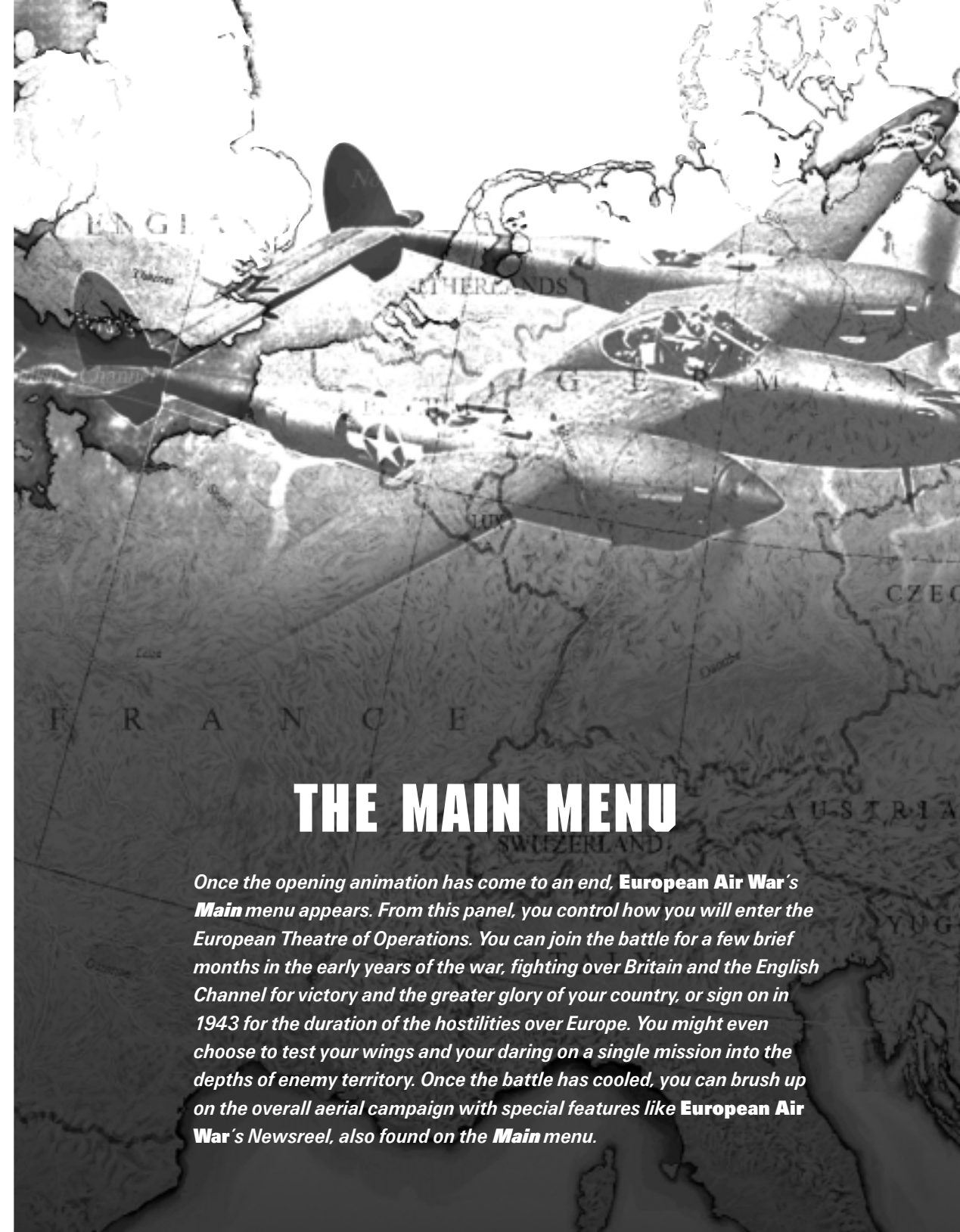

THE MAIN MENU

Once the opening animation has come to an end, *European Air War's* **Main** menu appears. From this panel, you control how you will enter the *European Theatre of Operations*. You can join the battle for a few brief months in the early years of the war, fighting over Britain and the English Channel for victory and the greater glory of your country, or sign on in 1943 for the duration of the hostilities over Europe. You might even choose to test your wings and your daring on a single mission into the depths of enemy territory. Once the battle has cooled, you can brush up on the overall aerial campaign with special features like *European Air War's* Newsreel, also found on the **Main** menu.



Main menu screen

- Quick Start** This is the fastest way to jump into the cockpit and get your first taste of air combat.
- Single Mission** Design and fly individual missions for either the Axis or the Allies. Single missions are a good way to practice in preparation for a piloting career.
- Pilot Career** Start your career as a pilot for the RAF, USAAF, or Luftwaffe.
- Configure Game** Choose how to control your aircraft and other aspects of the game.
- Multi-Player** Test your aerial combat skills against those of your friends.
- Newsreel** Watch brief films on some of the major aerial operations in *European Air War*.
- View Objects** Examine—in detail—all the planes in *European Air War*.
- Exit** Quit the game and return control to Windows.

Our thanks to RAF Wing Commander James Isles (Retired) for these brief insights into the air war in defense of England, and for all the other information he so thoughtfully supplied.

A PERSONAL EXPERIENCE OF A CIVILIAN

The Sunday morning of 3rd September 1939 was beautifully sunny and warm, with the first tints of autumn beginning to appear. On this particular morning, I had motored from my home in North Berkshire to be with my future wife, who was at that time nursing at Lord Mayor Treloar's Hospital at Alton.

For many months, there had been speculation whether or not there would be war or peace in Europe in our time, since Hitler was already using force to gain his way with a programme of annexations. It was known that the offer of British support in the event of anyone threatening the independence of Poland had become relevant on the 1st September. Thus, Britain was under obligation to stand by her treaty.

An ultimatum issued by the British Government to Germany for the withdrawal of troops from Poland had been rejected by Hitler. Thus, the Prime Minister made his radio broadcast to the British people. The Matron of the Hospital at Treloar's had invited me into the hall where staff were assembled to listen to the announcement. I shall always remember the empty silence in that hospital in the moments that preceded the broadcast. When Mr. Neville Chamberlains, the British Prime Minister, came to the microphone to speak to the British nation he said:

"This morning, the British Ambassador in Berlin handed the German government a final note stating that unless we heard from them by eleven o'clock that they were prepared at once to withdraw their troops from Poland, a state of war would exist between us. I have to tell you now that no such undertaking has been received, and that consequently this country is at war with Germany."

Those awesome words that came over the air on that peaceful Sunday morning stunned everyone into a silence like that which precedes an approaching storm. Within a few months, that storm front had broken for me, and I had become a Volunteer Reserve in the Royal Air Force.



A pre-arrangement with an elderly aunt of mine living in London was that if war was declared on 3rd September, I would drive direct from Alton to London, collect my aunt, and deliver her to some relatives in Berkshire. The general belief was that as soon as war had been declared, the German Luftwaffe would release an onslaught of bombers against major cities in Britain—but particularly on London. Having reached London in less than an hour and driving eastwards along the Great West Road, I noticed that the streets were almost deserted. I had seen some air-raid wardens ushering people into the shelters, and I realised that an alert had been sounded. My aunt lived in nearby Hounslow, and I arrived to find her and my uncle together with their dog in the air-raid shelter at the bottom of the garden, where I joined them until the all-clear was given.

As we found out later, soon after the declaration, two officers of the French Air Force had been on their way to join the Allied Air Mission in Britain. The Observer Corps had spotted the French plane crossing the coast and flying towards London, but they failed to identify the aircraft. However, it was plotted and transposed to the Operations Centre at Headquarters Fighter Command, who gave the signal “Air Raid Warning Red”. This brought the warning sirens into use, and the civilian population—believing that the German air raids had begun—made for the nearest shelters.

In the meantime, the French aircraft had landed at Croydon, a de-briefing had sorted the matter out, everything was in order, and the all-clear was sounded.

As it turned out, this was an excellent exercise to test not only the Air Defence System of the UK, but also the Civil Defence Organisation—all on the very first day that war had been declared.

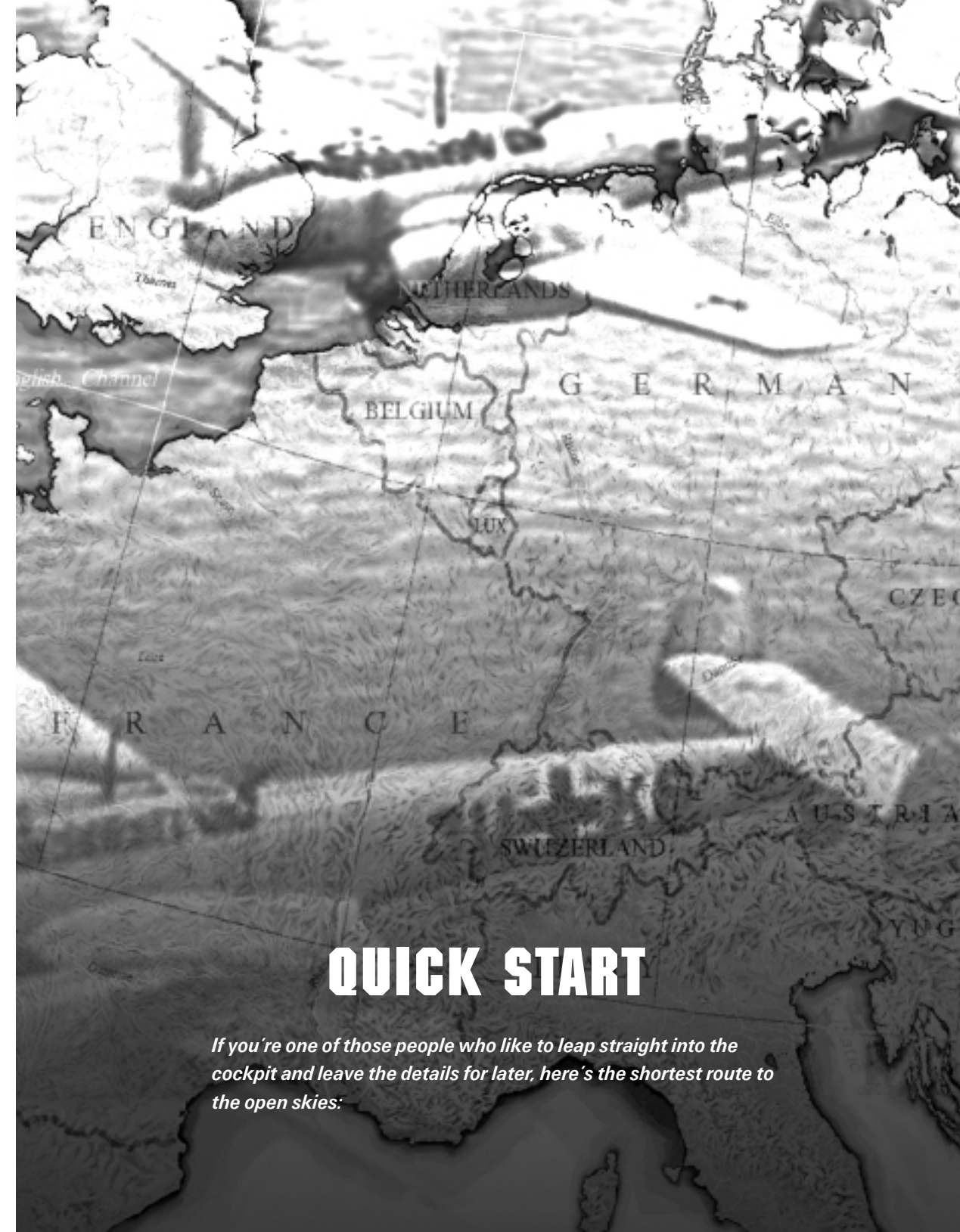

QUICK START

If you're one of those people who like to leap straight into the cockpit and leave the details for later, here's the shortest route to the open skies:



- ④ On the **Main** menu, choose **Quick Start**.
- ④ The game automatically recruits you for duty based on what plane you last selected in the Luftwaffe, Royal Air Force (RAF), or United States Army Air Force (USAAF) and designates where over Europe the air combat will unfold. **European Air War** also selects your armaments and makes all other pre-flight decisions.
- ④ Fly. The plane is already aloft and engaged with the enemy when you slide into the cockpit. The skill of your adversaries is based on the selection you made in the difficulty options. Your objective is simply to down them all before they do the same to you.

Quick Start missions use the same aircraft controls as the rest of the game. For details on how to pilot your plane, please refer to the **Quick Reference Card** and to the **Flying a Single Mission** section in this manual. Operations in Quick Start are small in scope, covering less terrain than other available flights, but they let you dive in and get your feet wet (preferably not in the drink). At mission's end—success or your own untimely demise—you receive a mission summary report and then return to the **Main** menu.



FLYING A SINGLE MISSION

*In the thick of war, there's precious little time for showing young pilots more than the basics, but lack of experience will get you killed out there. Don't risk it all—life, limb, and love of flying—without adequate training and preparation. **European Air War's Single Mission** feature lets you test the waters. Take the opportunity to practice the same maneuvers time and again until you master them. Train in a particular type of mission or plane, or strive to be an all-around pilot with superior skills in a variety of different circumstances. You might even want to try flying your enemy's planes to see what advantages and disadvantages they may have. Single missions are also perfect for those not suited to the rigors of military life.*

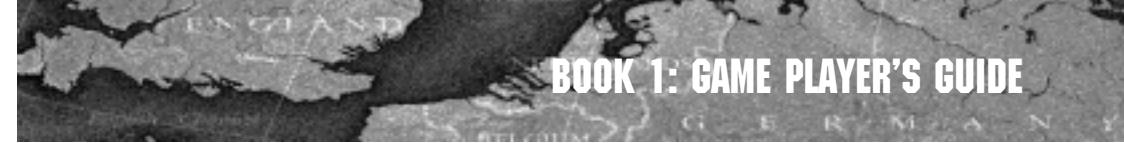

The **Single Mission** menu puts you at the controls, helping you design and carry out your own missions without having to answer to your superiors. You decide what kind of sortie to fly, and in which model of plane. You determine what enemy forces you'll face. You choose your target. You even select the weather. Better yet, since you're not a career man, you've got nothing to lose. Here you have no past and no future, but can afford to live for the moment. *Carpe diem!*

Once you have selected the **Single Mission** option from the **Main** menu, you see a board posted with pictures of the different planes you can choose from. Each board contains only planes from one nationality. You can select a different nation by clicking on the name of the country at the bottom right, near the **Exit** button.

Since you'll be flying one of the planes you order aloft, it's a good idea to pick something you actually want to pilot. Maybe you're training as a specialist in a particular make and model, or perhaps you'd like to try something altogether new. In any case, be sure to settle on a plane that captures your interest. After you select a plane, you can set your mission parameters.

THE HANGAR



British Hurricanes await servicing in the hangar.

In the hangar, ground crews have been working feverishly for hours to prepare your plane. Your fuel tanks are topped off. Now it's time to make some final decisions before taxiing down the runway. Make your selections carefully, as they'll determine how difficult a mission you face.

You have several options as you wander around the hangar waiting for orders to man your craft. Use the mouse pointer to search the shed until you've found each one, or simply press the **Spacebar** to reveal them all.

MISSION PARAMETERS



Mission Parameters screen

The first time you create a mission, the parameters are on their standard settings. Thereafter, they default to those from the last sortie you prepared. Move around the document, clicking on the highlighted words to cycle through your available choices.

If, as you fill in your preferences, you find that things aren't turning out quite as you'd planned, don't worry. You can go back and change things at any time; you can even reload and edit a mission after you've flown it and saved it.

TIME PERIOD

Select the year of battle. The date influences which aircraft models are in the mission; only those in production in the year you choose are available for you and your opponents to fly.

TIME OF DAY

Adjust the time of your take-off. Note that as your mission progresses, the light shifts to reflect the time of day (or night). Depending on the hour of take-off and the length of your flight, the sun may rise or set while you're aloft.

WEATHER

Even a Group Commander doesn't have control over the weather during an operation, but then, he usually doesn't get to choose which planes the enemy plans to fly, nor how many of them he'd like to meet in battle. So as long as we're departing from reality, we might as well go all the way.



Cloudy skies over England

Weather always has its say in determining if it's possible to take to the air on any given day, but during World War II this was especially true. In heavy cloud cover, lacking modern instruments and technologies, bombers couldn't bomb and pilots couldn't take off (or, worse, land). Yet weather could also turn the course of an aerial skirmish; a pilot might use a well-placed cloud or a strategic moment in the sun as effectively as a complicated maneuver to elude the enemy.

INSTANT ACTION

This option, available only on single missions, is for those players itching to get embroiled in the fray. Click in the box to proceed directly to the combat area (as in a Quick Start mission), with no lengthy flight to endure before you encounter the enemy.

MISSION TYPE

There are five basic mission types from which to choose. As each kind requires aircraft specially tailored for its different goals, your choice of mission will limit the models of plane available. Possible assignments include:

Fighter Sweep A fighter sweep is a flight designed to clear the skies and ground of enemy aircraft, often in preparation for a following strike force. Fighter planes fly ahead and soften an area's defenses, clearing the way for bombers or—less frequently—a second wave of fighters. The more damage a sweep can inflict on its target, the greater the chance for a successful follow-up strike.

Bomb Target This is a strike meant to damage and destroy enemy ground units and structures. Oil plants, armament factories, sub pens, radar towers, warehouses, bridges, hangars, and barracks all make good marks. A strike often follows on the heels of a sweep, hoping to catch fighters refueling from the earlier contest. Ideally, you want to pounce before the enemy has had time to repair any defensive installations or grounded aircraft that suffered damage in the previous raid.

Interdiction Less structured than other types of operations, these "search and destroy" flights generally patrol a particular area, attacking any targets of opportunity encountered. These might include enemy planes, air control towers, hangars, anti-aircraft guns, trains, and convoys of ships or trucks.

Escort Escorts protect other aircraft, most often ungainly bombers, from enemy planes as they fly toward and over a target area. Frequently, escorts pass in the wake of a fighter sweep, which attempts to poke holes in the air defense system around the mark. Escorts hover near their more vulnerable compatriots, straying only as far as needed to protect against enemy threats. The survival of escort planes is incidental; their primary concern is to give the convoy safe passage to the target.

Intercept Intercepts are defensive flights dispatched to head off enemy aircraft. You must try by whatever means necessary to disrupt and disband attacking formations before they can inflict any damage.



TARGET

Each time you select a target, it is marked on a large map of the European theater. You can scroll the map in each direction by moving your mouse pointer to an edge. On the map, each target available for the selected time period is represented by a small white box. To select a target, place your mouse cursor on or near the white box (until the name of the target appears), then click.

NUMBER OF AIRCRAFT

This determines the number of friendlies. Depending on the number of primary and secondary planes you order up, you have the power to crowd the skies over Europe. If you're angling for overwhelming aerial superiority, go for broke and assign as many planes as possible, but if heavily congested airways don't appeal, you might consider something more modest.

CRUISE ALTITUDE

Select one of three different cruise altitudes: *Low*, *Medium*, or *High*. You can also use *Random*, to make each mission different.

HOME BASE

To a career pilot, home base represents everything. It's a safe haven after flying an operation, the chance for a meal, a shower, and bed, and it's where fellow airmen gather to share harrowing tales and stories of stunning success. But for you, home base is simply where all missions begin and end.

Your current home base appears on the mission parameter sheet. To specify a new home base for your mission, click on the name of the base. A map of Europe fills the screen, showing the available bases represented by white squares, your current base represented by your national insignia, and your target represented by a red square and an X. The white squares reflect the approximate locations of your country's actual bases of operation during the war. As you pass the mouse over each square, its name appears.



When you are selecting a home base, keep in mind your plane's fuel consumption and capacity. (Your range is marked on the map.) You need to have enough fuel for a dogfight and the return trip home. Click on the base that suits, and you return to the **Mission Parameters** screen, which now displays your chosen command post. To return from the map without designating a home base, simply press **[Esc]**. If you wish to view areas of the map that are currently off-screen, move the mouse pointer to the extreme edge of the chart, and you can pan up, down, or over.

FRIENDLY SUPPORT ACTIVITY: SECONDARY AIRCRAFT

Of all the criteria for your mission, none has more importance than the planes you send out for both sides. Different models of aircraft have different strengths and weaknesses. Tightness of turn, dive speed, service ceiling, and acceleration all vary according to a craft's design, and your plane's performance relative to your adversaries' determines whether you will be fairly matched. Each time you select a plane, the second picture on the right side of the screen changes to show that aircraft.

By opting for a specific mission type, you have already limited the models available for your sortie; for instance, a bomber cannot be the primary aircraft on a fighter sweep. The planes have to be suited to the mission at hand.





FORMATION SIZE

Determine the size of the formation of your secondary aircraft. Remember that, in general, the greater the number of planes flying on a mission, the slower the game performs. (This is also affected by the way you have configured the game options.)

PILOT SKILL LEVEL

Most flight instructors say there's no substitute for innate intelligence when it comes to being a pilot. If you haven't got it in the brains department, there isn't much anyone can do. But they also admit that grey matter isn't all that counts when it comes to being a good aviator. Experience and skill can carry you almost as far.

European Air War allows you to adjust the skill level of the computer pilots, both friend and foe. (Sorry—there's no comparable feature to enhance your own level of play.) Choosing between **Green**, **Seasoned**, and **Expert**, you can select the *average* level of pilot skill. This is not a guarantee that you won't encounter airmen of different experience levels. When you check **Seasoned**, for example, you might still run into the occasional greenhorn or ace.

EXPECTED ENEMY ACTIVITY: ACTIVITY LEVEL

Set this activity level to reflect the approximate number of enemy craft you'd like to take on with each encounter. Whereas *European Air War* permits you to pick exactly how many of your country's aircraft set out on a mission, your choices for enemy flights are limited to **Light**, **Moderate**, **Heavy** or **Random**.

PRIMARY AIRCRAFT

Select the type of aircraft you want the enemy to have as their primary plane. Each time you click on a selection, the third picture on the right side of the screen will change to the plane you just selected.

SECONDARY AIRCRAFT

Select the type of aircraft you want the enemy to have as their secondary plane. Each time you click on a selection, the last picture on the right side of the screen will change to the plane you just selected. Your choices might be restricted based on the type of mission.



AAA ACTIVITY LEVEL

Select the amount of anti-aircraft artillery activity you want to fly against. The higher the activity level you ask for, the greater chance the enemy will have of hitting you, since more flak will be flying in the air.

SAVING A MISSION

Once you have gone through and set all the mission parameters, chances are you'll want to save the script to fly (or edit) later. If so, simply click on the **Save** button.

At this point you have a couple of options for naming the new mission. You can save the scenario under the default name (the two primary aircraft), or type in a different name.

When you've chosen a name for the mission, click **Save**. If by chance you should pick the same name as an existing saved mission, you are prompted to confirm your choice (and permanently overwrite the old mission). Click **Change** to enter a different name for the scenario, or use **Save** to replace the older version with the one you have just created.

Naturally, if at any time you decide not to save your mission, use the **Cancel** button to return to the **Mission Parameters** screen.

But what happens if you elect to fly your mission without saving it, later to discover that you'd like to keep the set-up after all? As long as you haven't created another scenario, you can still go back and save it. Call up the **Mission Parameters** screen from the **Single Mission** menu. The settings reflect the last mission you designed. Simply click **Save** and proceed from there.

LOADING A MISSION

Starting a mission that you have saved is a snap—just choose **Load** from the **Mission Parameters** screen. A window opens listing all the saved missions. Use the mouse pointer to highlight the mission you plan to fly (you may need to scroll up or down the list) and then click on it. Next, click **Load** (again). The screen of parameters should pop up. At this point, you can:

- 1) Fly the mission as is.
- 2) Tinker with the mission conditions and then fly it immediately.
- 3) Fine-tune the parameters and save the mission for future play, then fly the newly saved scenario.

Click on **Cancel** if you decide not to load a mission design after all.

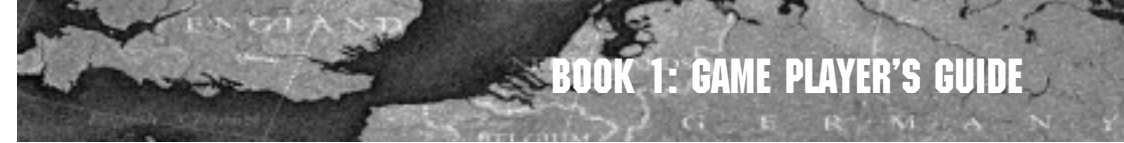

MAKING REVISIONS

Sometimes, after you fly a mission, you realize that it doesn't quite measure up. The plane doesn't respond as well as you had hoped, or the weather's not right, or you made the enemy too weak. Whatever the reason, you can always modify an existing mission. Load the old version (see above), which calls up the screen of parameters. Make your changes, and then save the new edition. Saving it under the same name will permanently delete the older copy, so if you wish to preserve the original version, save your current changes under a different moniker.

ARMAMENTS BOARD

Before leaving the hangar, you should check out the **Armaments Board**. Here, you select the weapons package you want the ground crew to load on board your plane and your wingman's. Click on the chalkboard to get to this screen.



Loading out

Your armament options vary according to the type of aircraft and the kind of operation you're undertaking. On a quick sweep, for instance, you might not be allowed to carry bombs, since the extra weight would slow you down and limit your maneuverability. On the other hand, a heavy external drop tank might be just the thing; although it will initially curb your speed, it will also increase your range, and you should be able to jettison the tank before it affects your maneuverability in close combat.

Highlight and click on the first flight you wish to arm, then cycle through the ordnance packages to be had. Your selections appear in writing next to the plane. On the projection screen to the right, you can see a slide of the load-out actually in place on the aircraft.

Select a load-out for each flight on the day's run, then click **OK** to return to the hangar. There you can at last begin your mission.



Ground crews like these, photographed in the early 1950s, stow your ammo and bombs aboard.

FLY MISSION

You've now cast the players and handed out the scripts, but be ready for a little improvisation once you get in the air. The beauty of *European Air War's* single flights is their lack of predictability. The game takes the settings you've plugged in and, within that set of limitations, generates an encounter. This means that with the exact same setup, you can end up in an almost infinite variety of skirmishes. You never know precisely what to expect.

Now that you have your mission loaded and customized to please, it's time to don your flight jacket and boots. Click on **Fly Mission** to climb into your plane and prepare to take the enemy by storm.

TAKE-OFF

It's show time! Slip on your parachute, adjust your scarf and goggles, and join your fellow airmen as they stride confidently toward their planes. Already, the buzz of engines fills the air. The first few flights clear the runway. After a final check with your ground crew chief, you climb aboard, strap yourself in, and prepare for take-off.

Almost every mission requires that you get off the ground. There's no two ways about it, but how you actually rise to the skies is up to you. Takeoffs can be tricky for the uninitiated. Lucky for you, *European Air War* lets you avoid them altogether, if you so desire. Just sit back and let the autopilot take over; it'll see you into the air and on your way without a hitch.



Lifting off

If, on the other hand, you think you're up to the challenge, here's the procedure:

- 1) Extend your flaps.
- 2) Start the engines by pressing **[Shift]+[I]** for a single engine plane and **[Shift]+[J]** to start the second engine in a twin engine craft like the P-38 and the BF-110.
- 3) Give your engines 90 or 100% throttle by pressing **[9]** or **[Shift]+[=]**.
- 4) Press **[B]** to release the wheel brakes.

- 5) Roll forward until your plane gains sufficient momentum. The exact speed needed for a smooth take-off differs according to the model of plane, but it's roughly 100–120 mph (160–195 kph) for each of the aircraft you can pilot in *European Air War*.
- 6) Pull gently back on the stick to ease your plane off the ground.
- 7) As soon as you are fully airborne, raise the landing gear (press **[G]**). This will reduce drag and improve lift.
- 8) When you're safely a thousand feet or so above the ground, pull in your flaps.

Once aloft, climb to a comfortable cruising altitude. How high you want to fly depends on your mission. To offer any protection, escort planes must remain fairly close to their bombers, but on other types of operations, your intended style of approach will determine your precise cruising altitude. Generally, greater height gives increased visibility and a better energy state.

At this point you can loosen up just slightly and give yourself a small pat on the back. You made it, but the best is yet to come.

GETTING THERE

Career pilots are under orders to fly a particular plane and to assume a particular role in flight formations. The pilot of a single mission does not have the same constraints. As your mission gets underway, you will find yourself in the lead plane of the primary flight (except on escorts, in which you will be the lead of the secondary flight). If you're comfortable with your plane and your role, great. If not, you can always change aircraft. Inexperienced pilots, for example, should probably not assume the lead; they have much to learn by trailing and watching their more seasoned cohorts. (See *Viewpoint and the Camera: Changing Planes*.)



Crossing the English Channel

Take some time at the outset to learn about your plane. The more you know about how it handles in different conditions, the better off you are in combat. Experiment with different maneuvers and learn how to make your craft do what you want it to do. You've got to control it, not let it control you.

THE COCKPIT CONTROLS

Before engaging in battle, you have to know your way around the cockpit of your craft. An explanation of the various dials and gauges can be found in the *Pilot's Handbook*, but here are a few notes on other features available as you pilot your plane.

MISSION MAP

Conveniently stashed in the cockpit is your very own map of Europe. When you press **[Alt]+[M]**, the map appears; it's a good idea to give the autopilot control of the plane before you open the map. Otherwise, you might want to pause the action once you have unfolded the map. Press **[Alt]+[P]** to do so. This allows you to take a good, long gander without losing any of your flight time. To restart the action, use **[Alt]+[P]** again.

Consult the map to review your intended flight path; icons plot the progress of all friendly aircraft. Press **[Esc]** or any of the view keys to exit the map. You return to the cockpit in the standard forward-facing view (or whatever view you selected). Your plane is moving at normal speed (unless you chose to pause the action).

COCKPIT RADIO

Combat pilots rely heavily on their vision and intuition to see them through battle, but their radio is also an important ally, a vital link to fellow airmen. *European Air War's* cockpit radio allows direct communication between you and the other pilots on your side. Call out a warning—Bandits at ten o'clock!—ask for help, or listen in as your flight leader issues new orders. Just be quick about it; you've still got a plane to fly.

To initiate radio communication, use the **[Tab]**. A menu appears, listing the people you can contact by radio—your squadron and Ground Control are on the same frequency; if there are other squadrons involved in your mission, they're on another frequency, and you cannot communicate with them. Press the key that corresponds to the intended receiver of your message.

When you're prompted, choose what type of communication you wish to send. If you don't see the exact command you're looking for, try the three menus—Tactical, Formation, and Navigation.

Finally, choose the statement you want to pass along. If you have opted to issue a command, you must select not only an action, but also the specific target. Pressing **[Esc]** at any time cancels your message.

Radio Commands

Commands are best sent *before* battle. How well commands are followed depends on pilot morale and skill. Dogfights can be quite chaotic, and you can't reasonably expect a rookie pilot to be able to quickly and efficiently rejoin you in tight formation during a heated battle. All pilots will do their best to follow orders, but don't always expect immediate compliance. As the British learned early on, it's difficult to remain in formation (which requires a constant eye to avoid collisions), *and* watch your enemies (and dodge their guns). It's normally wise to break apart or at least loosen formation prior to battle.



If you are the lead plane in an element, you can send commands to your wingman (you might sometimes have two), regardless of relative rank. If you are the flight leader (number one), you can command your entire flight. Only if you are the squadron leader can you send orders to other flights, or to the squadron as a whole.

Depending on the situation, you can issue some or all of the following orders to your wingman. (The default is *Cover Me*, so if you want any other behavior, you must order it.)

- Engage Bandits** Attack the enemy. If enemies have been sighted, your wingman is free to break off and engage. If there are no enemies in sight, he waits, then breaks off as soon as you make contact.
- Cover Me** Stay in formation, but if an enemy targets the lead plane (you), break off and attack until the threat is removed, then return to formation.
- Attack Ground Targets** Drop bombs (or launch rockets) at the mission's ground targets.
- Attack My Target** If out of formation, but in the general area, attack whatever is the lead plane's target at the time the command is issued. If in formation, stay in formation and fire at whatever enemy the lead plane attacks. (As in all combat situations, self-preservation can supersede orders; your wingman might need to break off from time to time to avoid enemy fire.)
- Disengage** Break off the attack on the current target. Lacking other orders, your wingman will probably return to formation, but might take shots at any easy targets on the way.
- Regroup** Give priority to getting back in formation—avoid enemies when possible in order to rejoin the lead. (In general, if you are trying to get planes back into formation, flying straight and slow makes it easier for everyone catch up and get in place.)
- Target** Attack enemies. The target commands are on the Tactical sub-menu. There are three choices: *Target All*, *Target Fighters* and *Target Bombers*. These order your wingman to focus the attack on the type of plane you specify (or all enemies). This overrides the default attack orders for the mission (for example, on a Bomber Intercept, the default is to target bombers).

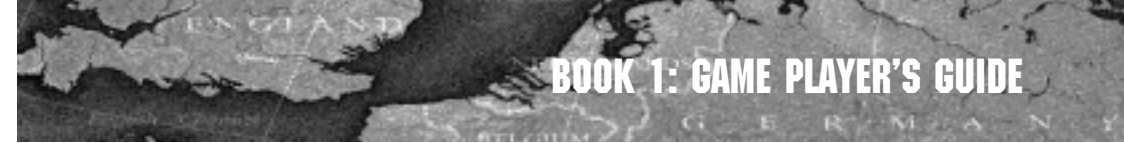

- Break** The Break commands are also on the tactical sub-menu. You can order you wingman to break *Right*, *Left*, *High*, or *Low*. This tells him to separate from you in the specified direction, generally so that the two of you can attack a target from different directions.
- Drop Tanks** Release the external fuel tank.

If you are the flight leader, you can issue nearly all of the same orders to your flight. The exception is that you cannot order the whole flight to **Attack My Target**. There are a few additional flight commands.
- Tighten Formation** Close up the formation. This command is on the Formation sub-menu. Tight formations look better, and when attacking bombers can result in more concentrated firepower, but the disadvantages normally outweigh the advantages.
- Loosen Formation** Spread the formation out a bit, normally about double the current space. This command is on the Formation sub-menu.
- Checkpoint** You use the *Next* and *Previous* checkpoint orders to get a loitering flight to continue on course or backtrack. (These commands are on the Navigation sub-menu.) The map includes navigation checkpoints, in case any plane becomes lost or gets hung up engaging the enemy, and these commands tell the flight to move to one of those checkpoints.
- Loiter Here** Circle the current position and await further orders. This command is on the Navigation sub-menu.
- Return To Base** Ground control normally gives this order, but as leader, you can decide (if you're massively overwhelmed, for example) to retreat and return home. Your mission will likely be considered a failure, but that's better than failing the mission *and* getting everyone shot down. This command is on the Navigation sub-menu.

If you're the squadron leader, you can give orders to flights other than your own, and to the squadron as a whole. Squadron Commands are the same as the flight commands, except that you can choose to issue them to the whole squadron or to a specific flight.

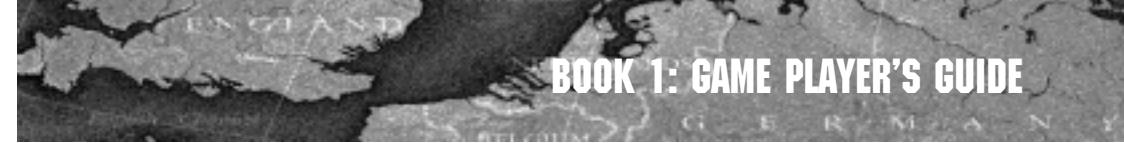

Ground Control

You can use the radio to call ground control and request a vector to the nearest enemy, a vector to your friendly bombers (if you're on an escort mission), or a vector back to home base. The vectors to the bandits and bombers are *intercept* vectors—the suggested heading for quickest intercept. Note that ground control is based on primitive radar and a network of civilian spotters. Therefore, some of the ground control information might be less than accurate.

You can call ground control to request assistance—additional fighters scrambled to help you out. Depending on how well the battle or war is going, there might or might not be any available.

Cockpit Red Light

Night missions were perilous affairs prior to the advent of radar. Nonetheless, wartime strategy requires from time to time that an operation begin before dawn or near dusk, and so your plane comes equipped with a small light to illuminate the cockpit dials. (In the dark, your instrument panel can be hard to read.) Since a bright white light could significantly reduce your night vision, the bulb produces a soft red glow. To turn it on or off, press **[Shift]+[L]**. The light works only after dark.

AUTOPILOT

All of the planes come equipped with an autopilot that can take over control of your craft in flight. (Historical purists should know that few of the aircraft you can pilot in *European Air War* actually had an autopilot installed, and none had one as sophisticated as this. It has been included strictly to ease game play in certain situations.) Upon encountering enemy aircraft, the autopilot notifies you of their presence and disengages itself, leaving you once again at the helm. Autopilot can also assume command during take-off to ensure that you get safely aloft. Of course, under no circumstances can autopilot save you when your craft has been damaged beyond control—you must bail out.

VIEWPOINT AND THE CAMERA

Now that you've had a chance to get acquainted with the inside of your cockpit, take a peek at the world outside the plane. It's time to try out the various viewpoints and your external camera.

F-KEY VIEWS

The F-key Views are a standard feature of many flight simulations. Pressing one of the numbered function keys changes your point of view. There is a slight overlap of views, so that you have no blind spots. The views are:

F1	Standard front-facing cockpit view
F2	Right wing, front view
F3	Right wing, rear view
F4	Over right shoulder view
F5	Over left shoulder view
F6	Left wing, rear view
F7	Left wing, front view

Use **[Shift]** with any of these keys to get a 45-degree up version of the same view.

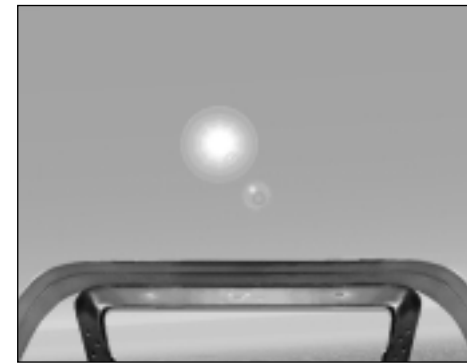

Full Up view



Lap view

There are a number of other controls that change your point of view. Most of these are for the external camera and are discussed in a later subsection. The other important ones are listed here:

[Ctrl]+[F1]	Lap view	Lower your eyes as low as possible to view the instrument panel
[F8]	Virtual Cockpit	Activate the Virtual Cockpit mode (see below)

FLYING A SINGLE MISSION



SNAP VIEWS

Snap Views allow you to quickly scan a field of vision using the numeric keypad. The key layout is designed in a very easy to use, logical order. The views are:

Numpad 1	Left Shoulder
Numpad 2	Six (blind spot)
Numpad 3	Right Shoulder
Numpad 4	Left
Numpad 5	Up*
Numpad 6	Right
Numpad 7	Left Front
Numpad 8	Front
Numpad 9	Right Front
Numpad 0	Instruments

* You can use the Numpad 5 key in combination with the other snap views to get a high view. For example, 5+3 looks up and over your right shoulder.

CHANGING PLANES

On single missions (but not on career operations or in multi-player games), pressing **Alt+J** allows you to jump into the cockpit of a different plane. This can come in handy. As a rookie, it might be more useful to assume position as a wingman than to fly the lead plane. You can gain valuable experience just by watching your more accomplished flight mates. Others (those with sadly deficient morals) might want to change planes after their own has been badly torn up. Repeatedly pressing **Alt+J** cycles you through each available aircraft on your mission (flyable planes only). Cycle too far, though, and you'll end up back in your original crate. **Note:** This feature is not available in a Pilot Career.

TARGETING

As a convenience, and to help simulate the way a pilot locks his attention onto a specific target and estimates the distance to it, you have the option of using the not-quite-historically-accurate *Targeting* feature.

Closest Enemy **Ctrl+T** puts the target marker on the enemy plane nearest you, and labels that marker with the name of the plane and its distance from you.

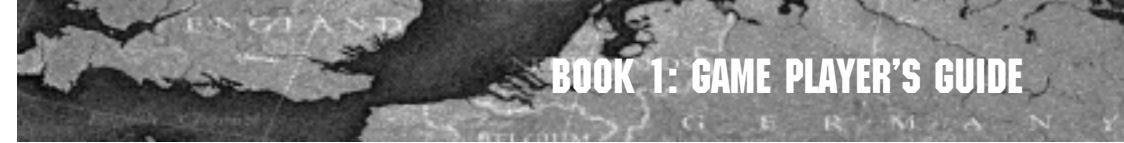

- Next Enemy** **T** moves the targeting marker to the next enemy plane. Using this, you can cycle through all of the enemies in sight.
- Previous Enemy** **Shift+T** moves the targeting marker to the previous enemy plane.
- Closest Friendly** **Ctrl+Y** puts the target marker on the *friendly* plane nearest you. Why would you want to target friendly planes? Hopefully, just to find out who's who and how far away they are.
- Next Friendly** **Y** moves the targeting marker to the next friendly plane. Using this, you can cycle through all of the friendlies in the mission.
- Previous Friendly** **Shift+Y** moves the targeting marker to the previous friendly plane.
- Clear** The **Backspace** key removes the targeting marker.

VIRTUAL COCKPIT MODE

The game's Virtual Cockpit view is the next closest thing to being in an actual cockpit. You can swivel your head and crane your neck just as a fighter pilot does, with none of the limitations (or frustrations) of static views. At first it's easy to get disoriented in Virtual Cockpit mode, but with practice, you'll find it extremely natural and useful in combat.

To access this virtual view, press **F8**. All the cockpit dials remain functional, and you still control the craft, but the camera control now moves your "head." Pushing the control forward tilts your head forward (and your view down), while pulling it back tips it back (and your view upward). Moving to the left or right pans in that direction. (Please refer to the *Glossary* if you need definitions of 'tilt' and 'pan.')

Using the virtual cockpit, you have the same range of view as a pilot in a real fighter plane.

PADLOCK

An added advantage of the virtual cockpit view is its padlock feature, which allows you to simulate the way a pilot keeps a single enemy aircraft in view at all times. Activate the padlock mode by pressing **Numpad** [*] (the asterisk on the numeric keypad). You can also turn it off with this key. Your view immediately shifts to your current target and stays on him. Once you've locked onto a particular craft, it's easier to maneuver until you face him, and then go for the jugular. Beware, though, the deadly threat of target fixation. That's when you concentrate on a single plane, completely forgetting about all the others training their sights on you. To exit padlock view, press any of the other view F-keys.

Use the **Numpad** [/] key (slash) to padlock the plane nearest the center of your view. Note that this is not necessarily the closest enemy, but it's the one you have the best shot at at that moment.

Note that you can activate the padlock feature even if you are not in the Virtual Cockpit. You are switched into Virtual Cockpit mode, then the padlock goes into effect.

THE EXTERNAL CAMERA

Hanging out in the pilot's seat is fun, but sometimes you want (or need) a different perspective on the world. Time to dust off the external camera, which lets you roam at will outside your plane, get a fresh view of a dogfight, or search in the distance for signs of the enemy. If you plan to stray far, consider enabling the autopilot—or pause the action altogether (**Alt**+**P**). This frees your hands and your concentration while you set up any unusual camera angle. Leaving an external camera view is as simple as selecting another camera viewpoint or any of the static views.



The external camera gives you a bird's-eye view of the action.

Camera Controls

Some of the external camera views allow you to control the camera and some do not. Some give you partial control. Regardless of what you can and cannot do with a camera, if you can control a specific movement, the keys you use to do so are always the same. The default mouse controls are:

LMB + [Fwd]	Zoom in or move forward
LMB + [Back]	Zoom out or move backward
[Left]	Track left (clockwise) around the plane
[Right]	Track right (counterclockwise) around the plane
[Fwd]	Track up—over around the plane
[Back]	Track down—under around the plane
RMB	Reset to original placement

You can use the keyboard and joystick, as well—with one or two slight modifications. If you plan to use a joystick with a "hat" to control the external camera views, first configure which button or key activates the zoom functions (which one acts in place of the LMB). You control all other camera movements exactly as with the mouse. When you're operating the external camera with the keyboard:

[H]	Track left (clockwise) around the plane
[J]	Track right (counterclockwise) around the plane
[U]	Track up—over around the plane
[N]	Track down—under around the plane

Camera Views

There are several different views for the external camera. Each has its own benefits, and the best circumstance for use of each depends on your needs. (Keep in mind that the keys listed are the defaults; if you've re-configured them, you must use the controls you set.)



Chase	Shift+F8	This view has the camera fly along with your plane and keep it in focus. You can inspect your craft from any angle, check for damage, or just admire the sleek beauty of your plane.
Flyby	Ctrl+F8	With this view, the camera positions itself ahead of your plane, then stays still and follows as you go by. It's a nice view, but it's not often useful.
Track Next	F9	Track mode functions much like the Chase view, except that it follows planes other than yours, and it sticks closer to the plane. This command changes the focus of the camera to the next plane. If the camera is not yet in Track mode, this command puts it in that mode.
Track Previous	Shift+F9	Change the focus of a camera in Track mode to the previous plane. If the camera is not yet in Track mode, this command puts it in that mode.
Target	F10	When you have a plane targeted (see Targeting for the scoop), you can get a close-up view of that plane using Target mode.
Player to Target	Shift+F10	This Target mode view positions the camera so that your plane is in the foreground and your target's in the background. The camera moves to maintain this relationship, which can be handy when you're trying to get in position to fire. If the camera is not yet in Target mode, this command puts it in that mode.
Target to Player	Ctrl+F10	This Target mode view is just like Player to Target, except that your target is in the foreground and you're in the background. If the camera is not yet in Target mode, this command puts it in that mode.
Bomb	F11	Any time when one of your bombs has been released but hasn't yet hit the ground, you can switch to a camera mounted on the bomb.
Player to Bomb	Shift+F11	Any time one of your bombs is in flight, you can watch it from a camera under your plane.
Bomb to Player	Ctrl+F11	Any time one of your bombs is en route, you can look back at your craft from a camera mounted on the bomb.

ACCELERATING TIME

As any World War II pilot knows, getting to the target area can take considerable time. Once you feel at ease in your aircraft, you can opt to speed up your trip. The game provides a way to hasten your jaunt. While not historically accurate, this feature nevertheless saves you the tedium of long stretches of flight with little action.

European Air War's time acceleration feature allows you to stay in the cockpit and use any of the external camera views while you move several times faster than normal. Pressing **Page Up** increases your rate of speed (for greater acceleration, repeat), while **Page Down** reduces it. For anything faster than four times normal, you'll probably want to engage the autopilot. At great speeds, even slight movement of the joystick can cause you to swing wildly out of control, with events happening so quickly that you may not have the chance to recover.

ENCOUNTERING THE ENEMY

Sure it's fun to fly—doesn't everyone dream of sliding into the cockpit of a fighter plane and soaring into the skies? Just don't forget that there's a war on. Sooner or later, you're going to come up against an enemy aircraft, and you'd better have a plan.

If you're new to flying, you should study the *Pilot's Handbook* for the skinny on combat tactics and maneuvers, but in the meantime, cast a glance through the next few pages. They'll get you started on the basics of battle.

IDENTIFICATION

As a military pilot, your first priority is to identify any unknown aircraft you encounter. Before you can take action, you've got to determine whether you've spotted an enemy plane or one of your own, and you'll have to do it without benefit of radar or the IFF (Identification Friend or Foe) systems routinely installed in modern warplanes. Sometimes you'll know just by how the bogey acts; opening fire on you is generally a pretty good indication of hostile intent. At other times, though, you must get close enough to identify a plane by its shape and markings. (If you'd rather not risk your own neck—and don't mind being unscrupulous—you can use the external camera to roam ahead and check things out long before you arrive on the scene.)

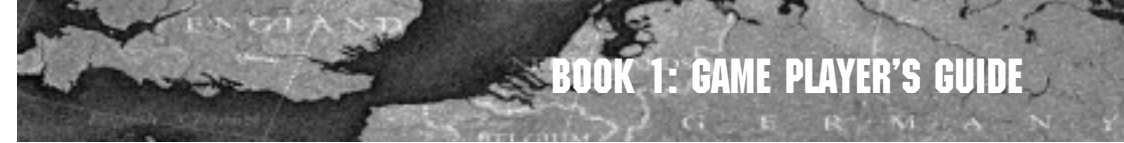

As with unidentified planes, you should also verify any and all ground targets before commencing an attack. If they're in the vicinity of the target's coordinates, they'll more than likely belong to the enemy, but they might not be your specific mission target.

Take heart that the enemy has all the same technological restrictions as you. They, too, must rely on visual identification. If you're sneaky enough about your approach, they may never even know that you are there.

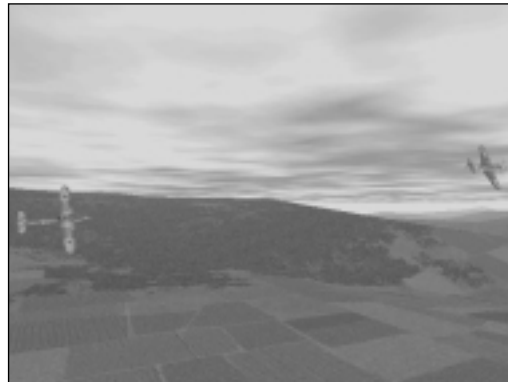

Closing in on the enemy

GROUND TARGETS

There are a variety of objects on the ground at which you can aim. These include bases, factories, forts, airfields, submarine pens, bridges, AA guns, and convoys of ships or trucks. Each carries different strategic or tactical weight. Many will be targets of opportunity on the return trip—a good way to rid yourself of extra munitions and to curry favor with your commanding officers.

CYCLING YOUR GUNS

Because ammunition is such a precious commodity, a pilot will often try to conserve his meager supply by firing only certain of his guns. Every fighter in *European Air War* comes outfitted with a feature designed to help you do just that. At the outset, your guns are set to go off in tandem. Using **[S]**, however, you can cycle through different combinations of firepower. (To cycle backwards, try **[Shift]+[S]**.) Since the guns are set up differently on each plane, cycling patterns vary among the aircraft. You can review the selections by pressing **[Ctrl]+[S]**.

DOGFIGHTING

Dogfighting refers to a close-quarters combat between aircraft. It evokes romantic images of World War I flying aces: the Red Baron bravely manning his triplane, scarf swirling in the slipstream. Yet these dogfights are anything but elegant. Your sole aim is to give the enemy a worm's-eye view of the world before he does the same to you. Speed, maneuverability, and a stout machine will all stand you in good stead, but in a dogfight there is no substitute for pilot skill—except maybe luck.

Fighter pilots entering battle must believe that they're at least as good as the next guy, and that means practicing. Only over time can a pilot establish a repertoire of trusted moves, and only through extensive combat experience can he cultivate a strong situational awareness. These are the tools that will see him through a dogfight.

The type of plane in which you enter a dogfight is important; generally speaking, you'll fare better if it's nimble. More important, however, is to know and exploit your craft's strengths. A bomber cedes the advantage of maneuverability to a lightweight fighter. However, if he plans it right, the bomber pilot has nothing to fear in close-quarters combat. Because of his craft's great weight, he can pick up plenty of speed in a dive and outrun most other aircraft. Anyone senseless enough to follow sets himself up directly in the sights of the tail gunner.

A few basic rules apply to dogfights. As in most forms of aerial combat, the higher plane has a distinct advantage. While a plane at a slower speed is more maneuverable than a faster moving craft and is capable of a tighter turn, it is also an easier mark. Against another fighter, strive to get in position behind and slightly above him. From there, you can dictate the course of the fight. Conversely, don't let your enemy linger long in that position, unless you can spare a few tail parts.

PADLOCK AND TARGETING FEATURES

During a dogfight, it can be difficult to locate and follow an enemy. *European Air War* includes a couple of features that, though not entirely historically accurate, can help you in times of need.

You can activate a targeting marker by pressing **[Ctrl]+[T]**. The marker places a box on the enemy plane closest to the center of your view and labels that box with the name of the plane and its distance from you. (See **Targeting**, in **Viewpoint and the Camera**, for more.)



Combine this feature with the Padlock feature (**Numpad** [*] and [/]), which has your view follow the targeted plane, and you should have no trouble keeping your enemy in sight. With a little practice you should be able to use these two features together to rack up plenty of kills. (See **Padlock**, in **Viewpoint and the Camera**, for more.)

DIVE BOMBING

Bombers exist for a reason; they're designed to pack quite a punch. Yet you'll find that with a knowledgeable pilot at the helm, other aircraft can also serve effectively on bombing runs. With a bit of practice, you'll hardly even miss having a true bomb sight, and though your explosives don't carry the same wallop, they're more than enough to do some damage.

All the same, don't kid yourself; dropping your bombs is a harrowing task that will push your aircraft to its limits. For one, your target is far from unwary. Enemy fighters swarm in droves around the bomb site, even when a successful sweep has recently blown through. There's no end to the flak from anti-aircraft artillery (AAA) on the ground, and to make matters worse, you have to fight your way down through all the traffic to have a shot at delivering your packages. It's a daunting assignment. Hope you've got nerves. Press [W] to arm your payload.

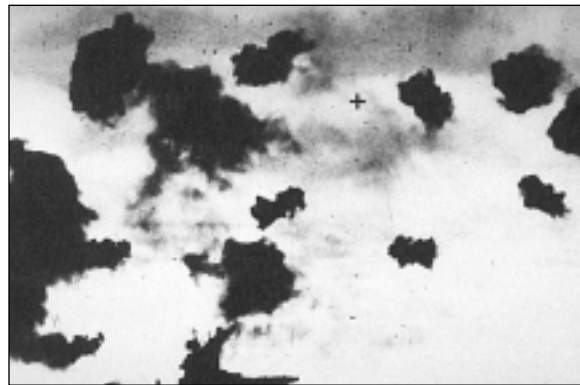

Flak from anti-aircraft artillery can be very dangerous.

Traditionally, a dive bombing run starts fairly high. In between jukes to dodge the flak, you've got to dive long enough to line up with the target. When you're almost over the objective, push your nose down into as close to a vertical drop as your plane can handle. (You'll learn in time what your craft can tolerate.) Using **Button 2** or [Enter], unleash your bombs *before* you're directly above the target. Since the explosives are moving with the same speed as the plane, they'll continue to travel forward after you release them. If you're firing on a moving target, take its motion into account as well.

The saying goes that a miss is as good as a mile, and generally speaking this is true. However, bombs can still take a heavy toll, even without scoring a direct hit. The closer you can get before releasing your payload, the better, but be sure to leave enough room to pull out before the ensuing explosion.

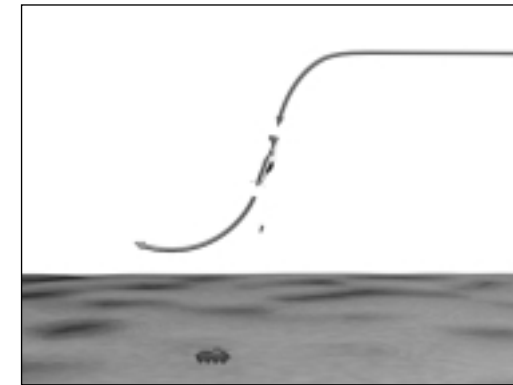

Standard dive bombing approach

STRAFING

Guns blazing, you swoop low over a landing strip and pepper the ground with lead—few methods of combat elicit the simple glee of a strafing run. Strafing means firing your guns at a ground target while making a low-level pass overhead. Most Allied fighter planes returning home from an escorting mission would expel all remaining ammo on any ground target that was on the flight path home. Many grounded Luftwaffe planes—as well as some train and truck convoys—were destroyed in this way. Don't underestimate the amount of damage you can do to the ground targets, or how easy it is for them to shoot at your tail as you pass by.

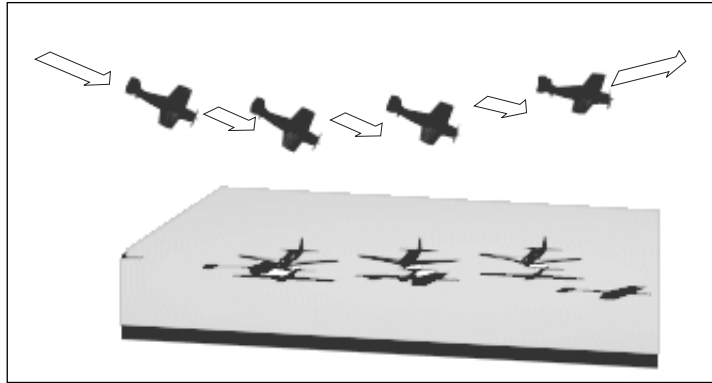

Strafing an airfield

The key to a successful strafing pass is to fly low and fast. Bear in mind that you will lose some altitude during the course of the run. Get low enough to fire, but not so low that you'll end up brushing the ground. Speed is also essential. To protect yourself from anti-aircraft fire from below, you must fly as fast as possible without sacrificing the ability to aim your weapons. Fire off your rounds, aiming as you would at any target in the air, then pull up at the end of your pass. If you've got the bullets and the bravado to make a second run, perform a wing over and have at it.



Effective strafing can be as devastating as a bomb—note the damage to this hangar.

FIRING ROCKETS

During the later part of the war, both sides had the ability to carry and fire rockets. These rockets were very basic, crude weapons that, once fired, followed a straight course until they hit an object. Most of the rockets were meant for ground targets, due to their inability to fly a straight path for a long distance. To use rockets on a ground target, Press **[R]** to arm your rockets, perform a strafing attack, and use **Button 2** or **[Enter]** to release a rocket salvo just before you are about to pull the nose of the plane up. Remember to get as close as possible to the target, since these rockets have a tendency to lose accuracy as they travel farther.

German pilots enjoyed using their rockets to break up bomber formations. the B-17 and B-24. To fire a rocket effectively at a bomber, you don't need to get close—1,000 meters or so is a good range.

GETTING SHOT DOWN

No one likes to ponder his own mortality, least of all a military pilot who depends on steady courage and confidence to get him through battle, but death is a fact of war. No one is immune. Fortunately, as the pilot of a single mission, you have multiple lives to squander. Each time you are shot down or bail out, *European Air War* reassigns you to the least-damaged friendly craft remaining aloft, and you find yourself in the cockpit once again. If the new plane doesn't suit your liking, cycle through the rest of the available aircraft and select another (see *Viewpoint and the Camera: Changing Planes*). There is no guarantee, however, that it will be airworthy. When the final friendly plane falls from the sky, your luck and your mission come to an end.

RETURNING AND LANDING

Unless your aircraft has suffered heavy damage, returning home should be no more difficult than the flight to the combat area. Just be sure to watch over your shoulder as you speed away from the target. Even in the face of devastating destruction, enemy forces frequently manage to mount an attack on parting planes. Approaching from behind, they are hard to pick up. Your best bet is to fly high and fast.



Once you're out of immediate danger, it might be tempting to cruise home in relative tranquility by letting the autopilot take over, but keep your eyes peeled on the return flight for "targets of opportunity." (This is when visual identification becomes both more difficult and more important.) Laying waste to a target of opportunity, in addition to raising your score, can help you dispose of leftover munitions that might otherwise break free on landing and cause headaches—or worse—at home base. If you plan on landing with bombs still aboard, you'd better make it a gentle touchdown.

If you'd rather not land your plane, you don't actually have to. Simply fly back into friendly territory and then quit. You proceed directly to your debriefing. (Note that if you quit the mission in enemy territory, you are not credited with a successful sortie.)

Many World War II pilots enjoyed performing a flyover before landing, wagging their wings to indicate a successful mission and a safe return. Unless you're a veteran, that kind of panache can get you killed; landing is the most difficult and dangerous part of flying, and it requires all of your concentration. A myriad of things can go wrong on a touchdown, any one of them enough to send you crashing to earth.

To land, you need to allow yourself plenty of room to maneuver. This is the most frequently ignored axiom of flight, and the most important as well. If possible, begin your descent a full three miles or more from the runway. As you approach, line your plane up with the edge of the landing strip, coming in only slightly above stalling speed. Avoid going too slowly, though, lest you lose control or stall your craft. Try also to refrain from making excessive corrections to your plane's attitude.

In preparation for touchdown, lower the landing gear and fully extend your flaps. Ideally, you'd like to come in steady and nose-high. Any tilt or sideways movement can throw off your approach. Try to touch down simultaneously with all three wheels. As soon as you set down on solid ground, cut the throttle and apply your wheel brakes. You should still have enough steering (using the rudder, *not* the stick) to guide your plane, just in case you're veering toward the edge of the runway.



Coming in with wheels down

DEBRIEFING

Following every sortie, you receive a mission summary detailing your performance. This info should be self-explanatory. It includes a recap of the objective and a tally of enemy casualties. Your total score is based on what you destroyed or damaged during the operation, as well as on whether the mission was a success. This is then modified by the difficulty settings that you selected before your flight began.

When you're done here, you are free to go. You have your choice of two options. They are:

- Re-fly** Immediately attempt the same mission again. The objective and all other parameters are exactly the same, although the point of enemy contact and number of enemies might well be different.
- OK** After a single mission, this returns you to the **Main** menu. If you just finished a career mission, this is how you return to the barracks.



A HURRICANE PILOT'S COMBAT REPORT

Whilst leading Red Section on a patrol SE of London, I noticed AA fire just west of London, and on investigation I noticed a force of some forty enemy aircraft which I could not immediately identify. I put my section into line astern.

I made towards the AA fire, when two ME109s appeared to my right. I turned and attacked them. I gave one a burst, and it half rolled and dived vertically to 12,000 feet, when it straightened out. I had dived after it, and as soon as it had finished its dive, I recommenced my attack. I was then going faster than the 109 and continued firing until I had to pull away to the right to avoid collision. The enemy aircraft half rolled and dived vertically, with black smoke streaming—it seemed—from underneath the belly of the aircraft. I followed it down until it entered cloud at about 6,000 feet and had to recover from the dive, as the 109 was then travelling at something like 480 mph. I then made my way through the cloud at a reasonable speed and sighted the wreckage of the aircraft burning furiously.

The aircraft was painted yellow from spinner to cockpit.

I climbed up through cloud and narrowly missed a JU88, which was on fire and being attacked by several Hurricanes. Unfortunately, as I was getting low on fuel, I could not make further contact with the enemy and so returned to base.

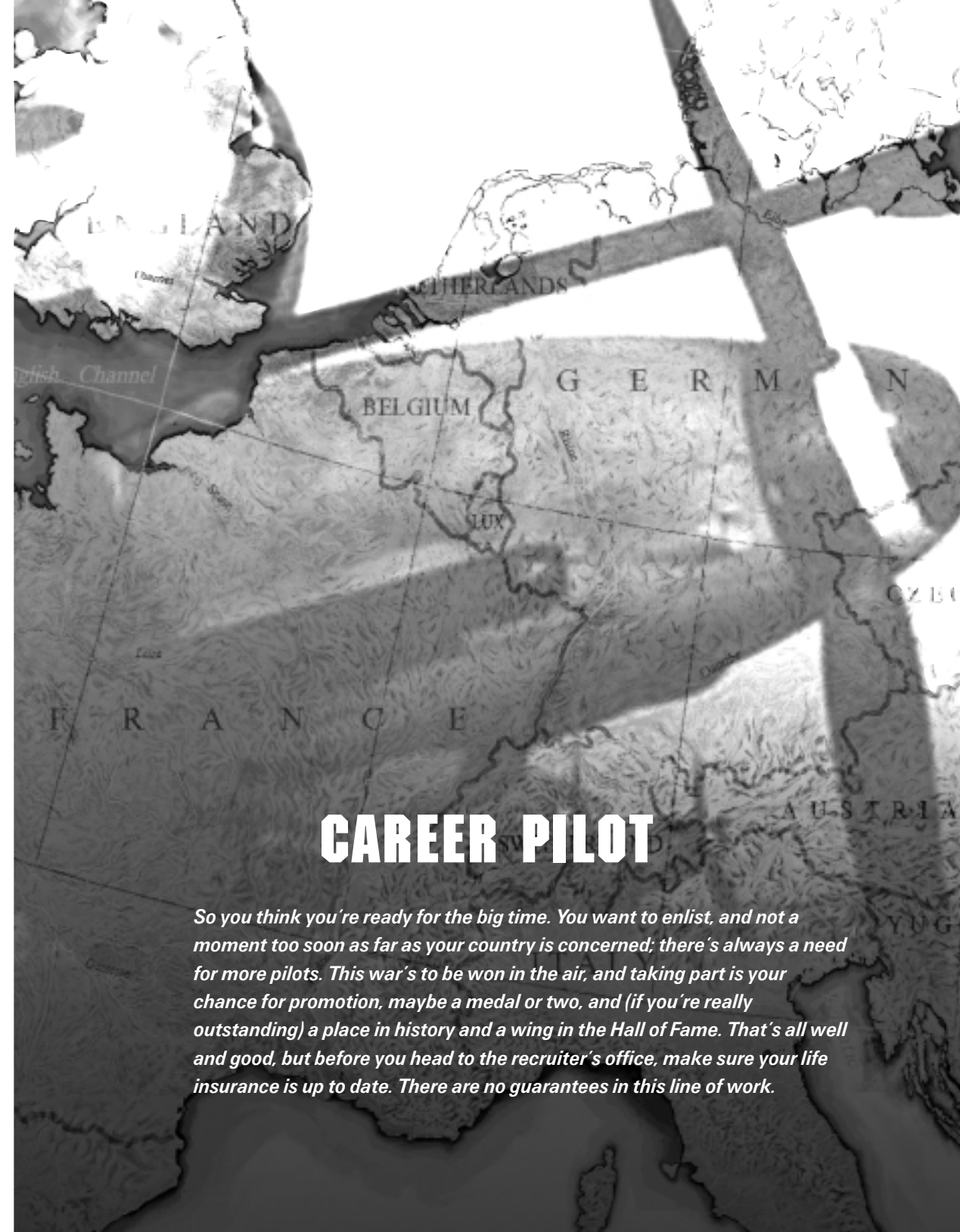

CAREER PILOT

So you think you're ready for the big time. You want to enlist, and not a moment too soon as far as your country is concerned; there's always a need for more pilots. This war's to be won in the air, and taking part is your chance for promotion, maybe a medal or two, and (if you're really outstanding) a place in history and a wing in the Hall of Fame. That's all well and good, but before you head to the recruiter's office, make sure your life insurance is up to date. There are no guarantees in this line of work.

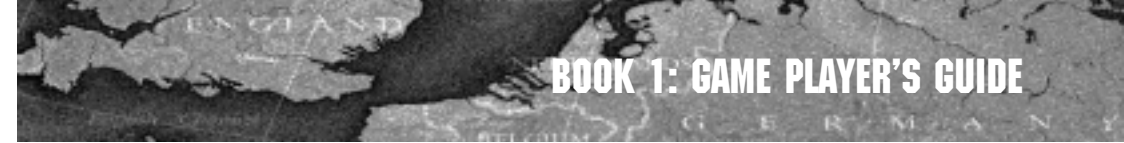

CREATING A PILOT

Joining up is simple, but there's still some paperwork to fill out before you receive clearance to fly. Once you decide to enlist, click **Pilot Career** on the **Main** menu. At this point, you choose the period in which you want to take part:

- Battle of Britain: 1940** Start a shortened tour of duty in the Battle of Britain.
- European Theater: 1943** Sign up for a full-fledged career in the European theatre of war starting in 1943.
- European Theater: 1944** Sign up for a full-fledged career in the European theatre of war starting in 1944.

In creating a pilot, your very first decision is whether to sign up for an abbreviated stint that lasts only through the Battle of Britain or enter combat in the European theatre of war. Click on whichever career you prefer. You must also to select which air force you want to join. Point and click on the nationality you wish to fight for. (Note that the United States did not participate in the Battle of Britain; to fly for the USAAF, you must embark on a full European career.)

There are a few other options near the bottom of the screen.

- Start** Begin the career, using the current selections.
- Load** Resume the career of a pilot already in the game.
- Hall of Fame** Rub elbows with the most celebrated aces of *European Air War*.
- Exit** Leave this screen without starting a career.



BOOK 1: GAME PLAYER'S GUIDE

When you choose **Start**, the game presents the **Personal Record** screen, where you set your name, rank, and unit. A name has been chosen for you, but if you prefer, you can create your own. Simply highlight the name box, delete what's there, type a name, then press **Enter**.

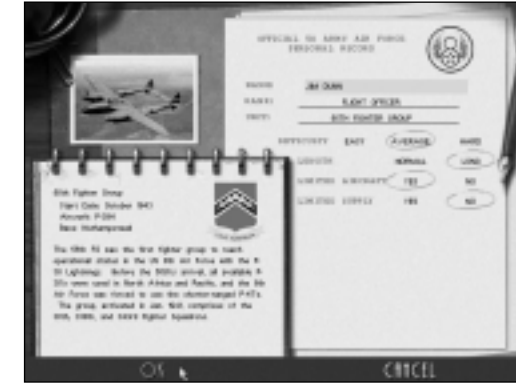

Personal Record screen

Next, using mouse clicks in the appropriate spots, cycle through the ranks at which you can start. Rank defaults to the lowest standing in each of the three air forces, but you are free to choose something a little more glorified. Higher rank lends greater control over decisions, but also greater responsibility. Don't get in over your head.

Now, you assign yourself as a new recruit to a specific unit. The group or wing you highlight determines which plane you fly in your initial action. For a European career, it also affects the date of first combat. Highlight your choice of group or wing and click on it. Then designate one of the squadrons or *staffel* detailed to this group.

Finally, you have the option to change the settings that determine some of the overall characteristics of your career.

- Difficulty** Select the overall level of challenge you want to deal with; among other things, this affects the flight and combat skill of the other pilots.

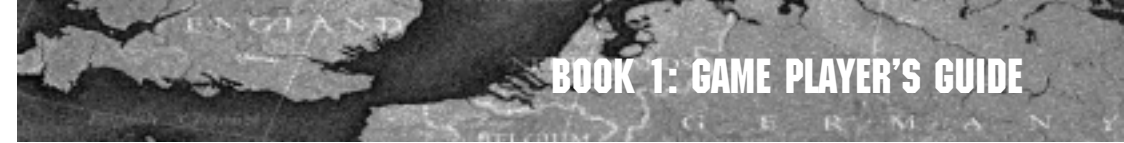

- Length** Choose how long a hitch you intend to sign up for—*Normal* or extra *Long*.
- Limited Aircraft** If you turn this on, you can lose a career not only by being killed, but by losing too many aircraft in the course of the campaign.
- Limited Supply** When enabled, this provides the added realism of limited access to vital equipment; the availability of drop tanks, rockets, and other supplies might be curtailed by the vagaries of war.

You are now ready to launch your career. Click **OK** to accept your recruitment and assignment. The pilot data is automatically saved (although you can't load it until you've flown at least one mission as that pilot). Military officials welcome the newest airman to the conflict with a brief message (you can bypass this by pressing any key) before handing you over to your commanding officer. Report immediately to the **Briefing Room**.

If, for whatever reason, you prefer to scrap your career, click on **Cancel**, and you return immediately to the **Career** menu. From there you have the same choices as before: to create a new pilot, load an existing career, or exit to the **Main** menu.

LOADING A CAREER

Sometimes, instead of creating a new pilot identity, you want to resume a career in progress. No problem. From the **Career** menu, choose **Load**. (The option is available only if you have previously created and saved at least one pilot career.) *European Air War* furnishes you with a list of all the saved pilot careers, as well as the airmen's nationalities and present status. You can continue an active career or permanently delete a pilot from the list.

- Continuing** To continue a career already in progress, move the mouse pointer to an active pilot and click to designate your choice. That pilot's career resumes when you click **OK**.
- Deleting** For those undistinguished pilots whose careers are floundering or downright dead in the water, or for any other airman whom you might wish to polish off permanently, the **Load** menu offers a **Delete** function. Remove any pilot from the list of saved careers by highlighting his name and clicking on (surprise) **Delete**. You must verify this choice, so that you can't accidentally snuff out your most promising pilot in mid-career.

As always, **Cancel** returns you directly to the previous menu.

THE BRIEFING ROOM

The **Briefing Room** is your first stop after starting or loading a career. Here, you join the others in your squadron and await the call to man your planes. You have no idea what the day will bring.

Unlike single missions, career mission assignments are handed down from above. Remember, you've officially renounced any ties to the civilian way of life, including the right to act on your own initiative. You've got no control over the planned strategy of aerial encounters (your chain of command reserves that honor), and you'll probably never even hear all the details—the less you know, the better, lest you somehow fall into enemy hands.

There are a couple of things you can count on, though. You will carry out the same kinds of missions that you flew in training (refer to *Mission Type* in the *Flying a Single Mission* section for details), and you'll never have a mission completely free of enemy resistance.

Listen up. Your commanding officer is about to fill you in on the details of your day. This is the only chance you have to learn about your mission—when it starts, where the target is, what kind of enemy activity you can expect, and all the other nitty-gritty particulars. Your life depends on knowing this stuff, and your fellow pilots are counting on you not to let them down. The entire course of the war could hinge on the success of this one operation, so pay attention.

Your CO begins to brief you on your mission. As you listen, you can follow his words via the text at the bottom of the screen. During the talk, you view a detailed map of Europe, complete with your intended flight path, expected flak concentrations, and way points. Letters mark the way points in your journey—the coordinates ending each leg of your flight.

As any air force man will tell you, commanders tend to get long-winded, even in so-called *briefings*. If you'd prefer not to hear your CO drone on, just press **[Esc]** or click anywhere on the screen. Nowhere else in the military can you so easily silence those in command—and without fear of repercussions!

Following your leader's prepared presentation, you have the option to review the very same details at your leisure. Press the **[Spacebar]** to reveal all of your choices. (Wait until he's finished, though. Keep in mind that if you click anywhere, you'll cut your commander off—so take care not to use the mouse unless you mean to.)



Click on the map to examine your flight plan up close. Only a small area of the map is visible, but you can access other regions by guiding the mouse pointer to the edges of the chart. Press **[Esc]** or **OK** to return to the briefing room.

The mission description is also available for your reading pleasure. The better you know the details, the more prepared you are for the operation. If you didn't quite catch all the information or want to re-familiarize yourself with it prior to take-off, select the briefing room easel. Use **[Esc]** to exit the display when you're done.

When you're satisfied that you've absorbed everything possible about the mission's objectives, click **Continue** to move out to the hangar. Or if you prefer, **Quit** your career and return to the **Main** menu. (Your career will be scrapped for good, so don't take this action lightly.)

THE HANGAR

The **Hangar** for career pilots resembles that in **Single Mission**, with a few important exceptions. They are as follows:

ARMAMENT BOARD

Selection of weapons is contingent upon your rank. At low ranks, you may be unable to choose even your own armament load, while higher ranking officers can alter the ordnance selection for their own flights—and eventually armaments for each flight on the mission.

FLY MISSION

Once you've finished poking around the hangar, slip into your Mae West, check your dog tags, and click on **Fly Mission**. You're set for take-off. (Refer to ***Flying a Single Mission*** for details on getting aloft and piloting your craft.)

In contrast to flying a single mission, on a career mission you will not necessarily be in the lead plane at take-off. Instead, you are assigned a flight position appropriate to your rank and experience. You might want to glance around before lifting off, to establish your position relative to the other planes on your flight. The easiest way is to use one of the external camera views.



Awaiting your turn to take off

THE AERIAL CAMPAIGN

Career missions play out in much the same fashion as individual ones, relying on the same flight controls and types of encounters. Career flights, however, have an added dimension—time—which changes certain aspects of the game.

BATTLE LINES

The battle lines drawn between the nations at war move periodically during the course of the conflict. Towns and territories gain their liberty or learn to live under the harsh conditions of wartime occupation. Each battle line's movement more or less follows a historical timeline, but depending on the damage you inflict on enemy forces, you can hasten or put off the shift.

CHANGING BASES

During World War II, commanders constantly shuffled pilots (and other personnel) from base to base as dictated by strategic and logistic needs. You, too, may be called upon to move to a new location at any point for tactical reasons. In that event, you and your unit will receive packing orders. Allow a 48-hour delay while all support personnel and equipment arrive, and then you're good to go. At the next mission briefing, you get your first glimpse of your new home base.



REPAIRS AND REPLACEMENTS

In the wake of a raid, no air base crew twiddles its thumbs and sits idly by waiting for the next one. Instead, support personnel (and pilots) work feverishly to repair the damage and brace for the next onslaught. This holds in *European Air War* as well; ground targets undergo repairs and renovations. Just because you bombed the starch out of an airfield last week, knocking out the anti-aircraft artillery, munitions sheds, and runways, don't think for a minute that they won't soon be up and running again.

The supply of planes and pilots, too, requires constant replenishment as a result of wartime attrition. When necessary, your HQ furnishes replacements, although—as in any war—your unit may not receive a full complement, supplies being at times limited.

PILOT FATIGUE

Pilot fatigue was a serious problem in the Second World War. It arises when airmen fly numerous missions in a very short period, with little chance for rest. Flying every day, a pilot can never fully relax, and the mental strain takes its toll over time. Fatigue threatens a person's reactions and decisions, the very cornerstones of a fighter pilot's skills. Yet in the thick of the hostilities, commanding officers can't necessarily afford to ground their airmen or send them away for a week of R&R. In *European Air War*, no pilot—except perhaps you—is immune to the effects of fatigue.

COCKPIT RADIO

Your rank and flight position determine whom you can contact by radio and what you can say. Anyone can make observations, give warnings, or request help, but all other radio communications are restricted. Your options depend on your rank. (Please refer to **Cockpit Radio**, in *The Cockpit Controls*, for details on using the radio.)

RESCUE, CAPTURE, AND DEATH

Your plane went down, and now you're stuck. All you can do is snack on bugs and bits of bark as you wait for someone to happen by. Who comes to your rescue depends on where you wound up.

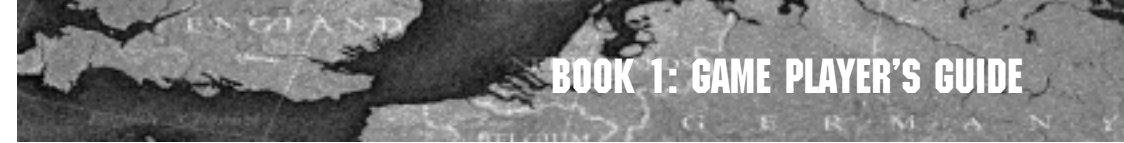

CAREER PILOT

If you landed in one piece in friendly territory, you'll no doubt be picked up by locals and wend your way back to your unit. Behind enemy lines, though, you have a much slimmer hope of flying again for your country. Of course, there's always the off chance that the resistance might smuggle you to safety, but it's far more likely that you'll wind up a prisoner of war, scratching out an existence in an enemy camp. A POW's career as a pilot is as good as over.

Death is the only thing worse than internment as a POW. How you die doesn't much matter; the result is the same. You're history; your career is at an end. Perhaps you can take some small measure of consolation knowing that your death and discharge were honorable, so your family will receive your pension.

DEBRIEFING

At the end of every career sortie, you get a written debriefing—even those of you who didn't make it back. If you thought that by dying on the mission you'd be exempted, you were wrong; the military owns you in death as in life.

MEDALS AND PROMOTIONS

Sure, everyone dreams of returning home a highly decorated war veteran, and you're no exception. You'd love to be the toast of the town. To be a hero, though, you've got to act the part, which means earning your laurels in battle. Medals are awarded in recognition of incredible feats of daring, bravery, and courage performed in the line of duty.



A slew of medals



Given a stellar service record, you might someday earn promotion to a higher rank. In part, this reflects recognition of your increased knowledge and skill, your growth as a pilot, and your battle experience. You must also have demonstrated potential as a leader, and there must, naturally, be a vacant position. If chosen for promotion, you should feel honored and lucky to have made the grade. If the chain of command passes you over in favor of another, climb back into the cockpit and work out your anger on the enemy.

BARRACKS

Back at the barracks after the latest flight, some pilots catch a game of poker, some read the mail from home, and the smart ones retire for some shut-eye. Drift around the room to find all of your options. (Press the **[Spacebar]** for assistance.)



USAAF barracks

LOGBOOK

The **Logbook** lets you view the various missions you have flown throughout your career. It details the date and type of flight, the target location, the number of kills you tallied, and other statistics. To change the page and peruse missions not currently displayed, use the **Previous** and **Next** buttons. Press **[Esc]** or click **Exit** to return to the barracks.



VIEW MEDALS

After a particularly rough day in the cockpit, you might feel the need to console yourself with mementos of your past glory. If you're a decorated veteran, **View Medals** allows you to do just that with a simple click on the footlocker. You can select any medal by moving to pointer over it and clicking. This calls up the original citation. When you're done, hit **[Esc]** or **Exit**.

RADIO

One way to relax at the end of a grueling mission is to lie back and listen to some of your favorite tunes playing softly on the barracks radio. The radio has a couple of short selections of music from which to choose. A click on the barracks radio turns it on, and subsequent clicks change the station.

LEAVE

The door from the barracks leads you directly to the **Main** menu. In the process, it saves your campaign.

BUNK

Back in the barracks, select the bunk to advance to the next mission while saving the previous day's flight.

TOUR OF DUTY

German pilots, once in the Luftwaffe, fought 'til the bitter end—either their own or that of the Second World War. The only ways out of service were capture, death, and dismemberment. American and British pilots didn't have it quite so tough; they signed up for a tour of duty, at the end of which they either retired or re-enlisted.

You have it easier than they did. No matter which nationality you choose, each tour of duty last approximately one year, at the end of which you have the option to retire. If you re-up, subsequent hitches also last a year.

SQUADRON COMMANDER'S OFFICE

Hope you enjoyed the promotion ceremonies, because now that you're commander of an entire squadron, there's going to be no more goofing around—too many lives depend on you. As a symbol of your new status, you now have your own quarters, complete with a softer pillow specially requisitioned for your sleeping comfort. Not that you'll get to use it much; as Squadron Commander, you're never off duty. While you pace back and forth across your office, keep an eye out for the options you have, or use the **[Spacebar]** to reveal them. They include, among others, viewing your logbook and medals or humming along with the radio (all of which you should remember how to do from your time in the barracks).



A squadron leader's quarters

There are a few notable differences between your old digs and the new ones.

SQUADRON BOARD

The **Squadron Board** lists all the airmen in the squadron, their rank, missions flown, and other data.

Pilot's Name	Rank - Missions	Reference
Sgt. Ldr. Harvey Brown	0 / 1	Aircraft Shot
Wt. Off. Sydney Gardner	0 / 1	Hurricane T1 Operational 18
Wt. Off. Stuart Hay	0 / 0	Hurricane T1 Damaged 1
Wt. Off. Bryan Gibson	0 / 0	
Wt. Off. Brian Hughes	0 / 1	Wt. replacement in 24 days
Wt. Off. Stuart Smith	0 / 1	
Wt. Off. Kenneth Marshall	0 / 1	
Wt. Off. David Smith	0 / 1	
Wt. Off. Carl Miller	0 / 1	
Wt. Off. Bruce White	0 / 1	
Wt. Lt. Bernard Williams	0 / 1	
Wt. Lt. Brian Stevens	0 / 1	
Sgt. Ldr. William Sullivan	0 / 1	
Wing Cdr. Blair Owen	0 / 1	

Squadron Board

Don't discount the data here; remember that experience significantly affects pilot performance. If an airman has flown a few missions, his skills are likely to be much improved over a green pilot right out of training. Fatigue is a factor, as well, and both exhaustion (too many missions) and taking too many days off between flights can strip a pilot of his fighting edge. It's up to you to achieve the best balance with your men.

THE END OF THE WAR

Sooner or later, the war will come to an end. You can escape home life only so long. And while we're disillusioning you, there's another thing you should know; no matter what you accomplish as a pilot—even if you manage to win the Battle of Britain for the Luftwaffe—the Germans are going to lose the war.

If you're alive as peace breaks out, you receive a final tally screen listing how you fared. Following a particularly distinguished career, you might even be honored with induction into the Hall of Fame.



HALL OF FAME

The **Hall of Fame** is a tribute to the all-time best pilots of the war. There you can see the aces from each of the three air forces in the European Theatre of Operations or view the best pilots from the Battle of Britain. With a little perseverance and a lot of luck, maybe some day you'll enter these hallowed halls. For now, look but don't touch. The top eight pilots in each category appear next to their rank, kills, and other info. For more details on any of the men, click on a name.

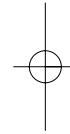
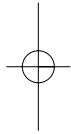



MULTI-PLAYER MISSIONS

*Competing against computer pilots is all well and good, but think how great it would be to smoke someone you actually know—a friend, your roommate, or even your boss. **European Air War**'s multi-player missions are designed for those individuals who want to test their mettle against real live people, not mere machines. After all, other human beings can be so much more devious than a computer—not to mention vindictive.*

*To get started, select **Multi-Player** from the **Main** menu.*



CONNECTING

Once you have selected **Multi-Player** from the **Main** menu, the **Connection** screen appears. This is where you begin the process of setting up or joining a multi-player mission. The first thing you should do here is name yourself. Click on the **Player** box (near the bottom) and enter the name you want to be known by during the mission.

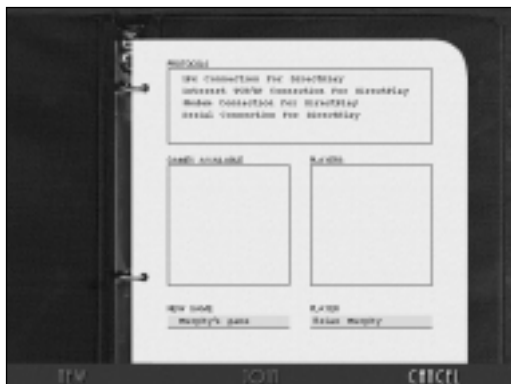

The next decision you must make—by selecting a **Protocol** option in the top box—is what type of connection you want to use. The connection determines both how many players can attach to the game and how their computers will hook up. All of the available options use DirectPlay to connect; they are:

- IPX** Connect to a local area network (LAN). A local area network is a bunch of computers all linked by a particular network system, as in many offices. (We are not suggesting that you play at work. Really.) Up to eight LAN players can do battle between themselves or against computer opponents.
- Internet TCP/IP** Connect to the Internet using a specific Internet address, or attach to a local area network using the TCP/IP protocol. Up to eight players can battle each other or the computer.



- Modem** Communicate via modem with a second computer. Modem games are limited to two players, who will either go head-to-head or work cooperatively against a common enemy.
- Serial** Establish a direct serial link to a second computer, using a cable strung between the two machines. A maximum of two players can join forces in battle or fight each other head-to-head.

Depending on the protocol you chose, you might need to enter some necessary data.

IPX

There is no extra data to enter for an IPX LAN connection. If you're connected to the network, the game searches for games currently running and forming and displays the game information for you.

TCP/IP

If you plan to join a game on the Internet, you must instruct the game to search for a particular host. To do so, type in a specific Internet address when you're prompted for it.

Leave the box blank if you intend to play over a LAN.

MODEM

Prior to modem play, both players should agree which computer will serve as the **Connect** computer and which will **Wait on Connection**. The player at the **Connect** computer acts as the host.

Both players must be aware of which Comm Port their modem is attached to and should know as well the baud rate of their modems. It's also a good idea to have the other player's phone number at hand. This might seem obvious, but you'd be surprised how often the most elementary things get forgotten.

Once you select the **Modem** option, you are prompted to specify whether you are the **Connect** or the **Wait on Connection** computer. Next, you must choose which Comm Port the modem is attached to and select the baud rate of the modem. Note that no matter what speed you enter, the game will default to that of the slower machine.



Finally, the player at the Connect machine must enter the other player's phone number and, thus, begin the attempt to establish the connection between the two computers. (The player whose computer is *Waiting on Connection* should just hang tight until the Connect computer links up.)

SERIAL

A serial connection is similar to a modem connection, except that instead of using the phone lines to hook up the computers, there is now a direct physical link—a cable—between them. Because modem and serial connections are so similar, the procedure players use for linking up with each other's computer is pretty much the same. Players must still agree whose computer will be designated to *Connect* and whose will *Wait on Connection*. Each player also has to fill in the *Comm* port and baud rate. In fact, the only difference between establishing a serial connection or a modem link is that for serial connections, you don't need to enter a phone number.

JOINING A MISSION

If you're joining a mission that's being set up and run—hosted—by someone else, then you've already done most of the work. Once you're connected, the **Games Available** box shows you the games you can access. (You can't join a game that's already started.) The **Players** box shows you who is involved in whichever game you select.

If you join a game, remember that the **Flight** and **Combat** difficulty settings for the mission are determined by the host of the game. Your default settings are not changed, but they're overridden for the duration of the multi-player mission.

When you're ready to join, select the game you want, then click **Join**. You proceed to the **Session Parameters** screen.

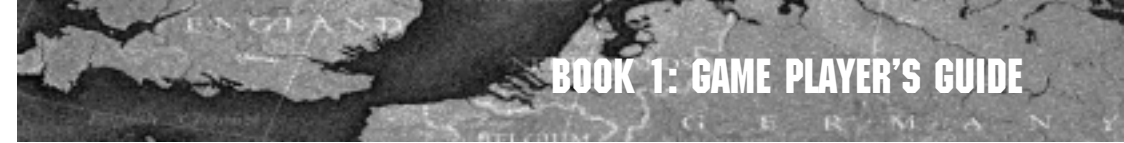

HOSTING A MISSION

If you're setting up and running the mission, you are the *host*. Hosting is not much different from joining a mission, except that you have more control over the situation. The first thing you get to do is name the game. Click on the **New Game** box, then type in the name you want to give the mission. Consider making it a name the other players you expect to take part will recognize easily.

If you host a game, remember that your **Flight** and **Combat** difficulty settings are enforced on everyone who joins the mission.

When that's done and you're connected, click **New** to proceed to the **Session Parameters** screen.

SESSION PARAMETERS

Now that you've arrived at the **Session Parameters** screen, much of the hard work is over. Here, the host sets the parameters of the game, and those joining choose their own place in the mission. If you're not hosting, your choices on this screen are limited, since only the person initiating the game can control certain parameters. If you're the host, you have control of the scenario.

The **Joined Players** box shows you the players who have already chosen to join the mission and the settings they have determined—name, nationality, and so on. The **Chat** box allows you to communicate with other players before the mission begins.

To change any of the parameters, click on the current setting to cycle through the options. They include:

Air Force Choose the country you wish to fly for. This decision affects which aircraft you can opt to pilot. Your air force also determines your enemies and your allies—except in games of *Total Mayhem*, where it's every pilot for himself.



- Aircraft** Choose the type of plane you want to fly; your options depend on both the time period (chosen by the host) and your air force. Your weapons load-out is determined according to the needs of the mission; you have no control over it.
- Region** The host determines the scene of the hostilities. The possibilities reflect historical battle areas of the selected time period.
- Time Period** The host selects the year in which the engagement will take place. Your choice influences both the battle region and aircraft availability for all players.
- Time of Day** The host stipulates the time of day at take-off. Options include anything from dawn all the way through nightfall, thus determining whether the sun or darkness will be a factor in the battle.
- Battle Size** The host selects the number of planes in the game. Settings include Small, Medium, and Large. This selection is independent of the number of players in the game; any planes without a player pilot are controlled by the computer. The number of player pilots can never exceed eight.
- Pilot Experience** The host sets the experience level of the computer pilots. This not only dictates the average skill, but also alerts potential players before they join.
- Mission Type** The host chooses one of the usual mission types for this operation. All forces on the same side as the host fly this mission; the enemies' objective is to prevent their success. For example, if the host selects an escort mission, the opponents find themselves flying an intercept. The exception is a *Total Mayhem* mission, in which it's every pilot for himself, with no allegiance and no objective but to survive and destroy.

When you're finished, click on **Launch** to begin (move on to your briefing) or **Cancel** to return to the **Connect** screen.

FLYING A MULTI-PLAYER MISSION

Once you're actually in the mission, you'll find that the similarities outweigh the differences. You get the usual briefing, then get airborne.

The aircraft in multi-player missions handle much the same as they do in Single Missions, but you'll notice a few slight differences. You can't, for example, use the time acceleration feature, and you cannot pause the action—period. That means you'll have to keep your wits about you at all times.

COMMUNICATIONS

In other missions, the cockpit radio is simply a means of communicating requests and commands between you and the computer pilots (and ground control). In a multi-player mission, the cockpit radio can be used in the same fashion, but it also comes in handy as a method of chatting with other human players—enemies and friendlies alike.

Press the tilde (~) to open the **Chat** menu. This gives you various options for sending messages to the other players in the mission. Choose your recipient(s), then type the text of your message. Press **Enter** when you're done, and the message goes out.

In the heat of battle, it's can be pretty difficult to type a full sentence without getting shot down. That's why the game includes some pre-set taunts that are available at the touch of a key. Using the menu, select the recipient(s) of your message, then hit one of the shortcut keys (**F1** through **F12**).

DEATH DURING TOTAL MAYHEM

Sooner or later, you'll probably get shot down or forced from the skies. If you're playing a Total Mayhem mission, don't panic—this isn't the end. You and your plane are "re-spawned"—recreated near the area of battle—so that you can continue flying and fighting.



PLAYER KILLS

Multi-player games keep a running tally of every pilot's kills. Players receive credit for downing enemy fighters and bombers. On the other hand, points are deducted for shooting down a friendly aircraft, for crashing a structurally sound plane, and for other such bonehead maneuvers.

If you're interested in tracking other players' records (as well as your own) during play, use **[F10]**. This places a kill tally on your screen. These scores are continually updated throughout the game. To remove this tally, press **[F10]** again.

THE END OF THE GAME

At game's end, you'll no doubt want to know how well you did. That's the whole point, after all. Just sit tight, and the **Final Tally** screen appears (unless, of course, you quit before the battle came to a close). The **Final Tally**, quite simply, shows the statistics for all players.

The overall air force winner (not listed for a Total Mayhem mission) is calculated based on the success or failure of each side's mission. The triumph of an escort mission depends on the number of bombers that made it over the target. Strikes take into account both the damage inflicted on the objective and the severity of one's own air casualties, while for an intercept to be a success, you have to have stymied your adversary. Sweeps are decided based on each side's total kills.

An overall individual winner is recognized as well. The title **Ace of Aces** is awarded to the player who, at game's end, has the greatest number of kills. This recognition is bestowed independently of the air force winner.



NEWSREEL

With the **Newsreel** option, those of you who aren't up on your history can watch brief snippets on some of the major aerial operations in *European Air War*. Three-minute narrated films present actual footage from the battles as well as commentary on the strategies involved. When you click on a particular battle, you're treated to a video of actual combat scenes. Once the segment has come to an end, you may view another or return to the **Main** menu.

VIEW OBJECTS

A valuable resource, the **View Objects** archives store a wealth of information about every plane in *European Air War*. Here, away from the frenzy of battle, you can study up on the technology of your adversaries, review a plane's dimensions, performance, and standard armament at your leisure, or learn to recognize different aircraft at a glance.

The **[Spacebar]** reveals your options. Click one of the decks to choose which set of planes you want to peruse. Use the **Previous** and **Next** buttons to call up different planes or models from the open deck. Whatever plane is currently visible, the **View Plane** option shows you the actual in-mission object for that aircraft, and **Details** calls up a listing of statistics for that plane.

For each plane, if the film canister is open and there's a film inside, you can view a one-minute multimedia presentation on that aircraft. The presentation includes a brief history of the plane, as well as slides or film footage of the craft in action. Once the presentation has come to an end, you can replay the piece or browse through the exhibit at your own pace. **Exit** returns you to the **Main** menu.



OBSERVATIONS OF A FLIGHT LIEUTENANT

A Flight Lieutenant who had flown Wellington bombers during the earlier part of the war, before being transferred to a Fighter Squadron, was making his first combat trip in a Hurricane. Enemy aircraft, including bombers and fighters, attacked Dover harbour in two waves, with their escort circling several thousand feet above, and formations of Hurricanes and Spitfires rose into the sky to meet the attackers. This is an observation of the combat made by the Flight Lieutenant.

"We were up bright and early waiting by our Hurricanes; suddenly we received an alarm enemy bombers were over the Channel. We raced to our aircraft, and just as the engines were starting up, the air-raid sirens sounded. We took the air to their wail. When we were at 8,000 feet, we made a turn and saw thirty or forty Junker 87s about to dive down and bomb four ships in Dover harbour. As we raced to intercept them, I watched the first low begin their dive. I watched their bombs falling when they got down to 2,000 feet and saw them exploding in the water around the ships. There were ten bombs at one time, and the water all 'round the ships was heaved up into a number of huge fountains.

"As we raced along at 300 miles an hour, I saw the bombers waiting their turn to go in and attack. Somewhere above were the escorting Messerschmitts. They were being looked after by a Squadron of Spitfires, so we had the bombers pretty well to ourselves. Not all of them got the chance to attack. A number of them did not get their turn. But I shall never forget the sight of them stepped up in the sky.

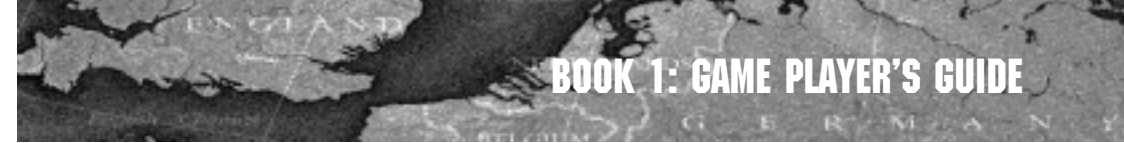

BOOK 1: GAME PLAYER'S GUIDE

"It was only a matter of seconds before we were flying down to our targets. I first saw a Junker 87 being chased by six Hurricanes, and I felt like cheering when I saw the bomber go down in flames. Immediately afterwards, another Junkers flew right across my bows. I raced after him, got him in my gun-sights, and let him have it. I was overtaking him fast, and when I stopped firing, he was covering my entire windscreen, only fifty yards away. I stopped firing because he blew up. I had heard about enemy aircraft blowing up in the air, and this was my first experience of it. Both his petrol tanks exploded at the same moment. Pieces of the aircraft were blown in all directions, and I had to dive away sharply to avoid being hit by the fragments. When I looked again, I saw the wrecked bomber tumbling down towards the sea. Then, below me, I saw three Junkers racing for home. They were only about thirty feet above the surface of the water, going away as fast as they could. I dived and attacked them in turn and chased them about a dozen miles out to sea. I gave the first one a good burst, and I knew I hit him. Then I blazed away at the second and hit him, too, before turning back.

"Our Squadron came out of the combat untouched, except for one bullet through the wing of one aircraft for four bombers destroyed and six others damaged—and some of them didn't even get the chance to drop their bombs.

"When I first saw the Germans, I felt a kind of fascination. I was surprised that I was able to see so much of the battle. After dealing with my first Junkers, I was able to notice other members of the Squadron shooting down other German bombers. I saw out of the corner of my eyes a short dogfight, which ended in one of our Squadron shooting down a Messerschmitt 109.

"One of the other things which stands out in my mind was a sailing boat with a big red sail steadily passing down the coast. Aircraft were blazing away at one another in the sky above. Occasionally, one would smash into the sea and disappear, but that little boat with the red sail appeared to take no notice. It seemed incongruous.

"When the battle was on, I was surprised because there was no confusion. Everything was very orderly. Each combat was distinct in itself. Things seemed to happen as in a well-rehearsed play. I was astonished to find myself able to be a spectator and a fighter at the same time. From the moment we took off to the moment we landed, exactly thirty-six minutes had elapsed, though I suppose the fight itself did not last more than five minutes. After that we had breakfast."



BOOK 2: PILOT'S HANDBOOK

*Welcome to the pilot training program for **European Air War**. The supplementary information in this portion of the manual is intended to help you stay airborne long enough to fulfill your duties. Though skill, daring, and marksmanship are extremely important factors in any aerial combat, it has been proven time and again that knowledge is the key to victory. When you know the enemy's strengths and weaknesses, you're ready to go into battle. When you know your own, you're ready to win.*

WHY YOU'RE HERE

By the outbreak of war in 1939, the aircraft had matured from the fragile, lightly armed, wood and canvas kites of the Great War into fast, heavily armed killing machines. In the 1940s, no army could win a battle on the ground if their enemy controlled the sky. In addition, the battle was no longer limited to the front lines. With bomber formations attacking cities and industry far from the field of battle, whole nations finally understood for the first time what it meant to be in a war. Combat aircraft had changed the face of battle forever.



THEORIES

Technology has always caused drastic changes in warfare. In less than three decades, improvements in aircraft design changed the way nations plan and prepare for war. Aircraft engines had become smaller, lighter, and more powerful. By the middle of the 1930s, wood and canvas biplanes had been almost universally replaced by all metal, mono-wing designs. Technology not only creates weapons and equipment, but necessitates new tactics as well. During the decade prior to the war, nations developed both aircraft and tactics to suit their own concepts of what would be needed in the next war.

Unlike those of ground and naval warfare, the strategies and tools of aerial combat changed radically between the First and Second World Wars. Whereas in the earlier conflict individual dogfights had prevailed, by 1940, this was no longer the case; whole new breeds of specialized planes had been designed that would forever alter war in the air. The advent of bombers, for instance, called for very different offensive and defensive strategies than those in use. Germany had spent the previous decade experimenting with novel techniques of battle, both in the Spanish Civil War and during top-secret training in Soviet Russia. Great Britain, on the other hand, had not substantially altered its approach to aerial combat. English flyers would now have to learn everything from scratch.

All nations planned on the tactical use of air power to influence ground battles. Fighters, the theory went, would gain control of the skies over the battlefield, much as their predecessors had in the First World War. Light bombers would then range over the battlefield, attacking enemy headquarters and supplies—as well as enemy ground troops. The Germans went an additional step, planning for their aircraft to function as mobile artillery. As the war progressed and experience mounted, the tactical importance of air power grew with it.

One of the most controversial developments during the Second World War was the bombing of civilian targets. For the first time, more civilians lost their lives due to military action than soldiers. The theory was that this “terror bombing” would break the morale of the enemy’s population, forcing them to surrender. The reality was far different. Germany was the first to use terror bombing, in the Great War and the Spanish Civil War, and it continued to use the tactic in Holland and Belgium. During the Battle of Britain, the Germans initially avoided bombing cities, but then accidentally bombed London. The British immediately retaliated, attacking Berlin and other German cities. This started a series of escalations, resulting in both sides switching more and more to area bombing of enemy cities.



Back in the 1920s, the Americans had been the first to propose and plan for an air campaign to destroy enemy production and military industry. American senior commanders disliked the concept of area bombing. However, most of the Third Reich’s factories and supplies were located inside European cities. The Americans invented and emphasized the new term *strategic bombing* to eliminate any criticisms, as their Army Air Corps developed the art of bombing industrial sites inside a city. By the end of the war, U.S. bombers were able to destroy their targets, but the collateral damage to surrounding areas was still extensive. It would be another fifty years before their dreams of precision bombing became a reality.

THE COMBATANTS

The Luftwaffe

The German *Wehrmacht* developed a combined air and ground doctrine, called *blitzkrieg*, or “lightning war.” To support this doctrine, the Luftwaffe evolved into a tactical air force the main focus of which was close air support of ground units. Its aircraft were designed to attack over relatively short ranges, carry lighter bomb loads, and hit small targets with precision. The German bomber force consisted of fast, twin-engine “*schnell*” bombers, perfect for supporting advancing ground forces, but inadequate for deep or so-called “strategic” bombing. This oversight did not become apparent until the Battle of Britain, and could not be corrected before the Allied bomber offensives began.

Until that battle, Germany had not needed a plane for those tasks; as each nation fell, the Luftwaffe advanced its medium-range bombers far into the newly conquered territories, where they could easily be launched against the next victim. The German warplane industry had thus skirted the issue of a heavy strategic bomber. Existing German medium bombers and dive bombers were meant to support—and be supported by—infantry, much like artillery. By 1943, it was too late. The Luftwaffe was forced to concentrate more and more on the fighter defense of Germany and could spend fewer resources on bomber development.

The Germans used four primary bombers during the war. The first of these, the Dornier Do 17, was one of the Luftwaffe's two principal workhorses during the early war years. Known as the "Flying Pencil" for its long and slender fuselage, the Do 17 had been converted from a civilian aircraft at the outbreak of war. It was considered the most accurate of the Luftwaffe medium bombers. The Do 17 was a favorite of both air and ground crews because of its reliability, but the bomber did have some shortcomings. Among other things, it was slow and had scant defensive armament. (Dornier crews were known to carry hand grenades and toss them out at pursuing fighters.) The plane also lacked the payload capacity of most other bombers. It took large numbers of Dorniers to inflict any lasting damage. The Do 17 was withdrawn from service in 1942.

The other workhorse of the early war was the Heinkel He 111. During Germany's masked rearmament of the early thirties, it had been introduced under the guise of a high-speed civilian transport and mail plane. At the outbreak of war, it was quickly converted into a medium-range bomber. When it first went into military service, the He 111 could outrun most single-engine fighters, and it placed Germany in the forefront of bomber technology, but by the Battle of Britain its fangs had already begun to dull. This bomber could easily be overtaken by the swifter English fighters.

The Junkers Ju 87 "Stuka" (short for the German word for "dive-bomber") had earned great notoriety as a precision bomber during the blitzkrieg of Poland and France. Its hulking form and fearsome whine damaged the psyche of the people as surely as its bombs ravaged the land. During the summer of 1940, though, the Stuka floundered badly—first at Dunkirk and then again in the opening encounters of the Battle of Britain. The Ju 87 served best in support of ground troops. Unaided by soldiers and artillery, it was out of its league. It was extremely slow and could not protect itself against a modern fighter defense, except when accompanied by a large escort. Heavy losses in the initial weeks over England led to the Stuka's redeployment elsewhere, in areas where it could exploit its strengths, but at lesser rates of attrition. Thereafter, it made only the occasional raid over Britain.

The Junkers Ju 88 was the newest Luftwaffe bomber. It was a versatile machine that undertook all types of high-speed bombing. In addition, the Ju 88 laid mines, performed reconnaissance work, and provided close support. It was sturdier than any other Luftwaffe bomber, and the plane's high diving speed allowed it to evade even the feisty Spitfire. The RAF considered the Ju 88 the most formidable plane in its class. As the war progressed, the Ju 88 progressed with it, becoming a night fighter, reconnaissance plane, and close support aircraft. This versatility made it arguably the best medium bomber design of the war.



A band of Ju 88s heads for Great Britain.

Besides its array of bombers, the Luftwaffe began the war with two fighter designs, the Bf 109 and Bf 110, both made by Messerschmitt. These were supplemented by both the Focke Wulf 190 and the Me 262 as the war progressed.

The Bf 109 was one of the fastest machines of any air force at the start of the war. It was an outstanding aircraft that outclassed its early opponents in most categories. The 109 responded quickly and cleanly to the throttle, was good in high-g turns and fast in a dive, and possessed remarkable low-speed handling. The 109 was fitted with a fuel-injected engine, which allowed the plane to fly inverted. The craft's greatest deficiency was its range; it couldn't go north of the Thames except on the briefest of sorties, and it often had to turn back even before it reached the target area. As a defensive fighter, the Me 109 continued to be a tough opponent throughout the war, undergoing numerous upgrades from the E-4 model flown in the Battle of Britain, through the G-6 and on to the K-4 version by the end of the war.

The Bf 110 *Zerstörer* (Destroyer), a twin-engine fighter with twice the range of the smaller Messerschmitt, was built for both offensive and defensive roles. Its designers envisioned a machine that could either clear a path for bombers through the defensive fighter screen or defend a region from the approach of enemy bombers. The Bf 110, however, soon proved a disappointment. It was too large and sluggish for a dogfight, and its top speed was slower than that of the British fighters. Squadrons flying the planes took unreasonably high losses, yet not until the end of the Battle of Britain were these planes taken off fighter duty and limited to reconnaissance work. The 110 was used with some success as a defensive fighter, and was a threat to unescorted bomber formations. Its replacements, the failed Me 210 and the Me 410, both suffered from the same basic problems. The Me 410, with its massive armament, was a formidable tank buster on the Eastern Front, and as a heavy fighter over Germany, it was a serious threat to Allied bombers. On the other hand, like its predecessors, it was no match for Allied fighters.

The Focke Wulf Fw 190 was designed in the late 1930s as a complement to the Me 109. The success of that design and a shortage of fighter engines delayed production until 1941. By this time, the need for additional fighters—and the use of a radial bomber engine—solved both problems. The Fw 190 was a fast and highly maneuverable fighter, and was a favorite of many Luftwaffe pilots. Produced in ten different versions, the Fw 190 was a match for any Allied fighter. The final version, the Fw 190D, used a Junkers Jumo inline engine instead of the BMW radial, had comparable flight characteristics to the P-51D, and must be considered one of the best designs of the war.

The Me 262 *Schwalbe*, or swallow, was the first operational jet fighter to see combat. The Me 262 was over 100 miles per hour faster than any Allied fighter, and it packed a tremendous amount of firepower. Its quad 30mm cannons were capable of destroying a bomber in a short pass. Unable to fight the 262 in the air, Allied fighters learned to attack them while they were attempting to land, and were therefore vulnerable. Many large scale dogfights occurred between Allied fighter sweeps and the normal German fighters trying to protect the landing 262s. Although the Me 262 had the potential to change the air war in the Luftwaffe's favor, it never lived up to this potential. Production was delayed for over a year by Hitler's insistence on a fighter-bomber design. This type of high level interference continued to plague the program until the end of the war, as production was needlessly diverted to production of night fighters and bomber versions. Less than one quarter of the 1,430 jets produced were issued to fighter units. Imagine the havoc that would have occurred if the American bombers had faced numbers of Me 262s in late 1943.

The Royal Air Force

Across the Channel, the RAF had different aerial needs. As early as 1937, Great Britain realized that it had fallen behind Germany in the production of bombers—but bombers are not critical for defense. Instead, fighters would be the saviors of the English. While bomber production never stopped, fighters were much cheaper to build. They were also in greater supply. At the outset of the battle, the English aircraft industry was suffering a shortfall against the number of planes contracted. The manufacture of fighters, however, had flagged only slightly; it had already been assigned priority, and the British were quickly tightening up the system of production. Between May 1940 and the war's end five years later, aircraft production never fell below the planned numbers.

In 1940, the RAF relied heavily on two types of fighters to save their island from invasion. When the battle began, more than half of Fighter Command's squadrons were equipped with Hawker Hurricanes, long a mainstay of the RAF. For a fighter, it was considered slow—the German Bf 109 was faster and could outmaneuver the Hurricane with ease—but what the Hurricane lacked in speed and rate of climb, it more than compensated for in other categories. It had a greater range than any other fighter, enabling it to maintain a longer flight. The plane had the added benefit of an older construction, which could be serviced at virtually any RAF base in Great Britain. Perhaps the Hurricane's greatest asset, however, was its armament of eight machine guns. The craft amassed more enemy kills during the battle than all other British fighters and ground defenses combined.



Fighter Command rises to meet the challenge.



Enemy tallies notwithstanding, it was the Supermarine Spitfire that attracted the public's eye. With its graceful and distinctive lines, it stood for the English people as the symbol of hope and victory. The Spitfire was not quite as durable as the sturdy Hurricane, and it was more vulnerable in places to enemy fire, but it had greater acceleration and was amazingly maneuverable. Pilots praised its superior handling. The Spitfire could turn a tighter circle than any other fighter used during the war, which let it get behind its German counterparts. Continued improvements to the Spitfire kept it in the front line throughout the war. The different versions, from the IXC through the XIVE, continually met the challenge posed by the improving German fighter designs.

The RAF also fielded some of the best fighter-bomber designs of the war. The Hawker Typhoon, which first saw service in 1942, was an excellent ground support aircraft. It was superseded in 1944 by the Tempest. This new bomber was one of the only interceptors with enough speed at altitude to intercept the V-1 "buzz-bombs," and Tempests managed to shoot down almost 35 percent of all of the V-1s launched against England. The Tempest's speed also made it an excellent choice to send against the Me262 bases. Perhaps the role both of these aircraft are best remembered for is as close air support fighter-bombers. After Normandy and throughout the Allied invasion, squadrons of Typhoons and Tempests ranged over the battle zone, attacking German units with cannon fire and rockets.

The Army Air Force

The American Army Air Force had several advantages over the British and Germans. The geographic isolation of North America had insured that the AAF possessed both long range fighters and strategic bombers. Between the wars, American aviators had led the world in strategic and operational bombing theory. Finally, America had the advantage of two years of combat in Europe to prepare for the war. These factors, combined with America's industrial capacity, insured that the USAAF would be a potent factor in the war.

American heavy bombers were unique in being designed from the outset to fly long range, unescorted missions deep into enemy territory. They were built on extremely tough airframes and carried an extensive array of defensive machine guns. The standard American bomber at the start of the war was the B-17 "Flying Fortress," a name the aircraft more than lived up to. In Europe, the AAF fielded two major types of bombers, the B-17 and the B-24 "Liberator." The B-24s were used in Africa and Italy, while the B-17 carried the brunt of the fighting in England.



U.S. medium bomber designs were, in effect, scaled-down versions of their heavy bombers. The best example is the B-26 "Marauder." These aircraft were intended to perform missions against the same strategic targets as the heavies, but only at intermediate ranges. This would allow the AAF to attack in depth and spread the enemy defenses. During the war, the medium bombers came into their own on interdiction missions, attacking transport and logistics targets and isolating the German front lines from reinforcements and supplies.

The AAF relied on variants of three fighters in the European Theater of Operations: the P-38, the P-47, and the P-51. The P-38 and P-51 were excellent air superiority fighters that could be pressed into service as fighter-bombers if needed. The P-47, on the other hand, was a fighter-bomber that also made an excellent fighter.

The P-38 "Lightning" was designed as a high altitude interceptor, but its speed, power, and durability led to its use in almost every type of fighter-bomber mission. Lightnings fought on all fronts of the war, and the aircraft remained in production in several variations until the end of the war. The first P-38s were deployed to England in 1942, but most were moved to Africa in late 1942, forming the backbone of the 12th AAF fighter squadrons.

The P-47 "Thunderbolt" was considered by many to be the best heavy fighter of the war. The Thunderbolt was an exceptional bomber escort and fighter-bomber. With drop tanks, it could escort bomber formations into Western Germany. Throughout 1943, the Thunderbolt was the main U.S. fighter over Europe. When the P-51 began to take over the bomber escort role in 1944, the P-47 became the main U.S. fighter-bomber. Thunderbolts earned a reputation second to none as a close support aircraft, and any ground commander felt better knowing a "cab rank" of Thunderbolts was overhead.

When most people think of a WWII aircraft, the P-51 "Mustang" leaps to mind. Any discussion of the best fighter in WWII will include the P-51. This agile, fast fighter was deadly in the hands of a trained pilot, and its ability to escort bombers all the way to the target was unequalled. The P-51 served in all fronts and beyond the war, remaining in U.S. service into the 1950s—and in some smaller air forces for another twenty years or more. Arguably, the Mustang was the best piston-engine fighter in history

WHY YOU'RE HERE



THE BATTLE OF BRITAIN

In the spring of 1940, Germany was on the offensive in western Europe. It had already conquered Denmark and Norway, and in early May, German troops began an invasion of France. Few doubted that if France fell, Great Britain would be next.

THE FALL OF FRANCE

Adolf Hitler's true designs lay on Soviet Russia. As early as 1939, he had expressed plans to invade the vast territory to the northeast. Taking Poland by storm had been the first step toward this objective, but it had drawn both the French and the English into the hostilities. Since Germany couldn't afford to attack two powerful adversaries at the same time on two separate fronts, Hitler wished to dispatch the threat from western Europe before proceeding on his conquest of the east.

As the closest powerful ally to the European coast, England received numerous appeals for military aid from countries already under attack. They poured in from across western Europe—Belgium, the Netherlands, and France all requested immediate assistance. Whenever possible, Britain responded. In France, the British Expeditionary Force sprang into action, as did the Royal Air Force, which committed both fighters and bombers to the battle.

There were those, however, who opposed such international aid, among them Air Chief Marshals Sir Hugh Dowding and Sir Cyril Newall, responsible for air defense over England. Arguing that committing more aircraft to the fray would do nothing except expose Britain to possible attack, Dowding and Newall fought to keep their men and planes in Great Britain. Air Ministry, however, was not swayed by their pleas, and the two men watched with dismay while their fighter defense was spread ever thinner.



The Germans marched with alarming speed across the European continent to its western shores. French opposition did little to slow the advance, even with British intervention, and in a matter of weeks the English began to pull out. The French could muster no further resistance. It was time for England to prepare for the defense of her own shores.

"We shall defend our island, whatever the cost may be. We shall fight on the beaches, we shall fight on the landing grounds, we shall fight in the fields and in the streets, we shall fight in the hills. We shall never surrender..." Winston Churchill, 4 June 1940

Under cover of the RAF, a massive evacuation took place in northern France. The Royal Navy—with the help of French, Belgian, Dutch, and civilian vessels—rescued more than 338,000 British and French soldiers from the besieged beaches at the port of Dunkirk. During the evacuation, the RAF made numerous reconnaissance runs and bombing raids, as well as nearly 2,750 fighter sorties. For many pilots, the experience gained was invaluable. Yet the French campaign took a serious toll; it claimed a number of front-line aircraft, including more than 500 of the RAF fighter planes that were soon to be in high demand. In addition, vital stocks of spare parts were abandoned in the rush to flee before France fell to the Germans.

Even more disheartening was the loss of skilled pilots. The majority of flyers downed during the Battle of France had been trained in peacetime, before extensive flight instruction had been sacrificed in the name of expediency. These airmen had practiced combat techniques and advanced flight maneuvers. They were far more experienced than those who would pass through flight school during the summer of 1940. They were also the men most qualified to take over command and lead newer recruits into battle. The loss of their expertise was a huge blow to the RAF.

"As England, despite her hopeless military situation, still shows no signs of willingness to come to terms, I have decided to prepare and, if necessary, to carry out a landing operation against her. The aim of this operation is to eliminate the English motherland as a base from which war against Germany can be continued, and if necessary to occupy the country completely." Adolf Hitler, 16 July 1940

WHY YOU'RE HERE



On June 17, a mere two weeks after the evacuation at Dunkirk, the French government requested an armistice. The next day, Prime Minister Winston Churchill made a radio address from the House of Commons. In it he announced, "The Battle of France is over. I expect that the Battle of Britain is about to begin... The whole fury and might of the enemy must very soon be turned upon us. Hitler knows that he will have to break us in the island or lose the war."

ENGLAND STANDS ALONE

In previous conflicts, England's geography—her island status—had protected her from much of the ruin inflicted on countries on the European mainland. It came as a great shock to the British people that their country might soon fall into enemy hands. Their armed forces had long been preparing for a German attack, but they had planned for one originating in Germany proper, some 200 miles distant. That attack could now be launched from anywhere along the French coastline, thirty miles and less than an hour's flight away. All of Britain battened down.

An invasion of England would have to come by sea, across the Channel, since the massive numbers of troops needed could never be transported by plane. German naval forces, however, were vastly inferior to England's; outlawed at the close of the First World War by the Treaty of Versailles, the German navy had not yet recovered to full strength. If Germany was to have any chance of transporting a landing force, the air force—the Luftwaffe—would have to attack British shipping, and before the Luftwaffe could have a clear shot at shipping, it would need to destroy the RAF.

The Luftwaffe, under the command of *Reichsmarschall* Hermann Göring, was organized into three *Luftflotten* (Air Fleets). In preparation for an assault on the English mainland, Luftflotten 2 and 3 had moved into position in Holland, Belgium, and France. Luftflotte 5, the smallest of the three groups, was stationed in newly occupied Denmark and Norway. Each Air Fleet was separate from the others. Each had separate supply lines for manpower and spare parts, separate weather forecasting services, and separate chains of command. Each prepared separate plans of attack to submit to Göring.



The RAF was also split into three primary groups: Bomber, Fighter, and Coastal Commands. (Balloon Command and Reserve Command, introduced in 1938 and 1939 respectively, performed lesser roles.) Of these, Fighter Command—led by Air Chief Marshal Dowding—was most crucial to the battle. True, ground defenses provided support and at times served to distract the enemy, and bombers attacked German holdings on the Continent, but because England had been forced into a defensive position, Fighter Command bore the brunt of the work in the late summer and early fall of 1940.

Following the Battle of France, there was a stay as the Germans gathered their strength, formulated a strategy, and redeployed their forces. The Luftwaffe continued nightly small-scale raiding of Great Britain, but these initial strikes were little more than a nuisance. In England, nerves were on edge; there was no telling how long the relative calm might last, and everyone knew it would be followed by a fight for the very existence of their country.

To a great extent, the element of surprise that had served the Germans so well in previous attacks on Poland, Norway, and even France was gone; both sides realized that the weather would dictate the timing of the offensive. For the planned invasion to have any chance at success, German troops needed to capitalize on the extended summer daylight and the relatively sunny weather. Conditions would soon deteriorate, preventing both air and surface crossings of the Channel. All the English had to do was repel the Luftwaffe's attacks until the coming of the fall storms.

Great Britain was on full alert, but only the Germans knew precisely when and where they were going to attack. This was a valuable advantage. England could only respond, not take the initiative, and for the first time in memory, the British had no one stationed on the European mainland to help warn them of impending attacks. Crossing the Channel could take as few as five minutes, but for Spitfires to gain adequate height to intercept incoming planes required at least fifteen.

WHY YOU'RE HERE



If Germany could ordain when battle would be joined, England at least had the edge of fighting over friendly territory. A Luftwaffe pilot who had to bail out of his plane was doomed to sit out the rest of the war in a prison camp, while pilots of the RAF were merely patched up and put back on the line to fly another day. Fuel consumption, too, posed a greater problem for the Germans than for the English. No single-engine fighter at the time was equipped to carry an external drop tank, and so Luftwaffe fighter planes were limited to a mere 80 minutes of flying time. An hour of that was used to fly back and forth across the Channel, leaving only 20 minutes over England itself. There was the very real possibility of ending up in the English Channel if German airmen exceeded these limits. English fighters had only to land at a local base and refuel when their tanks ran dry.

The Channel itself didn't discriminate between Luftwaffe and RAF when claiming its victims, and all pilots faced battle over the sea with a measure of dread. The frigid water could kill a man in a few short hours if he wasn't pulled from its grasp. Many a flyer died within sight of his own shores. The RAF had no coordinated system of air-sea rescue—not until August 22 would the subject officially be brought to the table—but the Luftwaffe operated an efficient rescue operation. It equipped its pilots with emergency flares, dye packs, and bright yellow skull-caps to aid others in locating downed airmen. Inflatable dinghies and "lobster pots" (sea rescue floats outfitted with everything from beds and blankets to food and water) allowed the men to get out of the cold waters, and specialized air-sea rescue planes diligently patrolled the Channel for survivors. In this way, the Luftwaffe returned at least a few pilots to the cockpit.

CHANNEL RAIDS

From the British standpoint, the battle began July 10 with a Luftwaffe attack on the large convoy "Bread" that was pushing through the Channel. An early morning reconnaissance mission directed the Germans to the convoy, and the dogfight that followed involved more than 100 aircraft. Only one of the bombs dropped on the ships below actually scored a direct hit, but the message of aggression was unmistakable.



At the time, although Hitler was proceeding with plans for a forceful invasion, he still hoped for a swift and uncontested victory. Some estimates gave the RAF no more than four days against the more powerful Luftwaffe, and Great Britain not even a month before invasion. Hitler expected the English to concede rather than face the ravages of an all-out air war. Nine days after the strike on Bread, the *Führer* delivered his "last appeal to reason and common sense" in front of the *Reichstag*. In it, he urged the British to surrender and avoid any further casualties or conflict. It was a suggestion the British flatly rejected.

"If this struggle continues, it can only end in the annihilation of one of us. Mr. Churchill thinks it will be Germany. I know it will be Britain. I am not the vanquished begging for mercy. I speak as a victor. I see no reason why this war must go on. We should like to avert the sacrifices which must claim millions." Adolf Hitler, 19 July 1940

"Hitler has now made it plain that he is preparing to direct the whole weight of German might against this country. That is why in every part of Britain there is only one spirit, a spirit of indomitable resolution.... We never wanted the war; certainly no one here wants the war to go on for a day longer than is necessary. But we shall not stop fighting till freedom, for ourselves and others, is secure." British Foreign Secretary Lord Halifax, 22 July 1940

In the following weeks, the Luftwaffe continued to make small forays against English shipping in the Channel. Göring also kept up his harassment of coastal targets. By attacking shipping, Göring hoped to draw the RAF into a small-scale battle of attrition which it would be unable to withstand. If the RAF refused to respond, then the Luftwaffe had free passage across the Channel and a clear shot at both the Royal Navy and the British shipping industry. Disrupting British trade would no doubt hasten the island's need to capitulate, and destroying the navy would open the English Channel to invasion forces.

WHY YOU'RE HERE



THE CALM BEFORE THE STORM

July and the first weeks of August were a period of sizing up the enemy. Luftwaffe fighter pilots tried to goad their counterparts into battle to see what they would face when the invasion got underway. They tested out RAF response times and British defenses. The English spent the spell fine-tuning their early warning system. Both air forces took stock of the planes to be involved in the battle.

By mid-July, Fighter Command had nearly 800 aircraft—100 Blenheims (which were soon to prove ineffective and relegated to night flying) and a total of 700 or so Hurricanes and Spitfires. These would face the more than 1,500 bombers and 1,000 Me 109s and Me 110s that the Luftwaffe devoted to the offensive. The odds were grim.

In its campaign against Great Britain, Germany needed an air force of both bombers and fighters. Its bombers would be key to damaging ground targets, while its fighters would perform escorts, reconnaissance missions, and close-combat sorties. The Luftwaffe had a good numerical balance between the two types of planes, and quality seemed to be on their side. As long as their objective remained the destruction of the RAF, this force was adequate. However, if the emphasis shifted to a general campaign against Great Britain, the Luftwaffe had (as discussed earlier) overlooked a critical requisite for a successful assault: the heavy, long-range, strategic bomber.

On the whole, the two sides' planes were well matched. Although the Germans had a sizable numerical superiority during the Battle of Britain, their fighters couldn't overpower those of the RAF, and as a result, pilot skill would weigh heavily on the outcome. In this the German air force had an edge in both confidence and combat experience.

At first the German pilots' greater expertise was quite apparent. Seasoned Luftwaffe veterans knew how to make the best use of the sky. They were famous for swooping down out of the sun on the tight, highly visible British formations, getting the upper hand in battle by spotting their opponents first. RAF flyers soon coined the watch-phrase "Beware of the Hun in the sun."

WHY YOU'RE HERE

Fighter Command's pilots learned the hard way that their tactics were obsolete. They were accustomed to flying in rigid formations, with fixed battle maneuvers to guide them through enemy encounters. In the traditional tight V formations, pilots flew in such close proximity to one another that just maintaining the proper distance consumed much of their attention. They were often too close to their leader and so had only an obstructed view of the skies ahead. Once the battle disintegrated into individual dogfights, each English flyer was vulnerable and alone. Over time, and after many painful losses, the British began to fly looser formations, but not until the end of the battle did squadrons begin to adopt the flexible "Finger Four" that the Germans used so effectively. In the Finger Four, each aircraft took the position of a fingertip on an imaginary outstretched hand. This decreased the flights' visibility and let pilots concentrate more on spotting the enemy rather than on maintaining a complex and tightly grouped formation.



The Finger Four formation

THE STORM BREAKS

Throughout the first month of battle, the Germans had no real plan of action. The army, navy, and air force were all at odds over how to proceed. The army urged a massive assault with three separate landings over a huge front. The navy, concerned about holding its own against a stronger British fleet, preferred a more concentrated front that would not stretch its resources to as great an extent. While Hitler weighed the different proposed strategies, he ordered the Luftwaffe to reduce its attacks on naval units and proceed with plans to overpower the RAF. Ground installations, supply networks, and the aircraft industry were all to be targeted—as were, of course, enemy planes. Once the RAF had been subdued, the Luftwaffe would be free to work on the southern ports and the Royal Navy.



July's clouds and rain precluded massive air assaults, especially by formations of bombers. Instead, the German air force launched a number of smaller raids. As British pilots rose to challenge the strikes, gaping holes appeared in their defensive screen. Air Chief Marshal Dowding's Fighter Command was unable to plug them all, and Luftwaffe aircraft slipped through to wreak havoc on the English countryside. The attacks grew in frequency as the month came to a close.

By early August, Fighter Command had lost nearly 150 planes, the Luftwaffe close to 300. The numbers foretold a dire situation for Dowding and his men. Although Fighter Command had so far withstood the swelling attacks, it would be unable to if the size and number of raids increased or if they threatened a wider area of coastline. Losses in recent days had begun to exceed production from the aircraft industry, a troubling sign. The outlook to Reichsmarschall Göring was less grim. His Luftwaffe could tolerate the current rate of attrition—as long as Fighter Command was in the end rendered impotent.

Although the weather improved dramatically in the first week of August, Luftwaffe activity came to a virtual standstill, and an uneasy calm ensued. Dowding attributed this in part to the reduction in the number of convoys sailing the Channel; throughout the battle, German air raid activity had been closely tied to the amount of British shipping. Still, Dowding could take little comfort from the slackening of the pressure. The RAF had yet to deliver a resounding defeat to the Luftwaffe—their few victories had been modest—and so in all likelihood, the Germans were gathering their strength for something more ferocious.

Dowding's fears were soon borne out; from the German vantage point, the battle was at last to begin in earnest. Having spent the previous month studying Fighter Command's defenses, Göring was now ready to mount a full-scale attack. Over several weeks, the Luftwaffe was to engage in repeated, crushing strikes on the airfields and radar towers dotting the southeastern coast. Known as *Adlerangriff* (Attack of the Eagles), this period of extensive raids was expected to bring the RAF to its knees, after which Germany could launch *Seelöwe*, or Operation Sea Lion—the invasion of Great Britain. Ground troops would be ferried across the Channel in converted river barges, tugs, motorboats, and large transport vessels, to hit the south coast of England in three waves. Once they—and large formations of paratroopers—had secured the English beachheads, they would push ever inland and closer to London, in the hopes of cutting the capital off from the rest of the country. British capitulation, the Germans believed, would surely follow.



ADLERTAG

The date for the start of *Adlerangriff* (called *Adlertag*, or Eagle Day) was initially set for August 10. Heavy clouds and rain, however, forced a postponement. Meanwhile, aerial activity over the Channel and English south coast gradually increased. Every day brought larger clashes. Pilots on both sides spent more than half of each day on alert. RAF squadrons flew an average of four sorties a day. Luftwaffe fighter squadrons flew three sorties a day, and bomber squadrons at least two. As the summer progressed, both sides routinely sent out almost 500 sorties a day.

August 12, the day before *Adlertag*, was consecrated to the wholesale destruction of radar stations from Portland all the way to the Thames Estuary. In 1940, radar was still emerging as a technology. It provided the remarkable ability to detect distant objects, revealing their location and speed. Both the German and English militaries had systems of radar, but although Germany was far ahead of Great Britain in actual technology, only the British had established a means of incorporating radar into their air defense.

England had erected a large number of radar stations, especially on its eastern coast facing the continent. Between these and the Royal Observer Corps (staffed entirely by volunteers) the RAF could detect almost all aircraft activity along the northern coast of occupied France and over the Channel. It could identify a Luftwaffe attack and determine approximately how large a force was needed to counter it, then dispatch the necessary planes to head off the offensive. Even though Reichsmarschall Göring was aware that the RAF relied on radar to some extent in their coastal defense (judging by the number of times German attacks had been successfully intercepted), he did not understand quite how the arrangement worked. Still, he wanted the system silenced.

WHY YOU'RE HERE



Radar stations like this dotted the English coastline.

Attacks on the radar stations went according to plan; bombers were escorted through the fighter screen and unloaded their munitions on the seemingly vulnerable towers of the Chain Home and Chain Home Low radar systems at Dover, Dunkirk, Pevensey, Rye, and Ventnor. The Luftwaffe also carried out hits on the British airfields of Hawkinge, Lympne, and Manston. Pilots returned with reports of apparently extensive damage at each of the sites. German High Command was ecstatic—they thought they had put the air defense system out of commission for some time to come.

Despite heavy surface damage, however, the raids on the towers were largely unsuccessful. Dunkirk continued transmitting without interruption, while Dover, Pevensey, and Rye experienced only brief suspension of their signals, thanks to their emergency systems. Ventnor was the most seriously damaged, and even it was up and running within three days. In the meantime, its silence was partially camouflaged by a built-in overlap of coverage and by the use of a portable signaling unit. When the Luftwaffe flew sorties later in the day to test how well they were picked up by Fighter Command, they found to their dismay that the British responded appropriately to the threat.

WHY YOU'RE HERE

August 13, the scheduled date for Adlertag, dawned cloudy and unsuitable for the day's planned operations. Despite his fears that Luftwaffe morale was slumping, Göring again delayed the assault. Unfortunately, the orders came too late for a flight of Dornier bombers and their Messerschmitt escorts, which had already left to bombard targets in Kent. Feldmarschall Albert Kesselring ordered the planes back by radio. Only the escort responded—the Dorniers continued along their course. Due to faulty radio equipment, they never received the message to head back to base, and in the heavy clouds they didn't realize that they were now flying unescorted. Ironically, that same cloud cover helped conceal the bombers and deliver them unscathed to their destination. The Dorniers unleashed their fury on a coastal air base at Eastchurch and a naval station at Sheerness. Then, hounded by a force of Spitfires, they fled the scene. Only four Luftwaffe planes went down on the mission.

When the bombers arrived back at base, however, they faced no hero's welcome, only a stern rebuke. Göring was livid that the flight had proceeded against orders—now Adlertag's carefully synchronized plan of attack was in jeopardy. Worse yet, the morning's effort had been in vain; the Dorniers had inflicted no permanent damage on their targets, which returned to operational status a short time later.

By mid-afternoon, the weather had cleared sufficiently, and Göring launched the rest of Eagle Day. Raids were to focus on western and central southern areas, as well as on a few selected inland airfields. Poor communication again threatened the operation; several groups of bombers failed to meet up with their escorts or rendezvoused only after considerable delay, throwing off the timing of the attack.

As a result of the confusion on Adlertag, the Air Fleets experienced heavy casualties. All told, the Luftwaffe lost almost 50 machines, while nearly that many more suffered serious damage. Fighter Command fared better; only 13 planes were knocked from the skies. (Although the afternoon's bombardment also claimed quite a few grounded RAF aircraft, only one was a fighter.) Nevertheless, Dowding did have cause for concern; under cover of cloud, many German craft had roamed at will over the countryside. If the weather was to continue in this vein, Fighter Command needed a viable means of detecting enemy planes even behind the clouds.

The next day, Feldmarschalls Hugo Sperrle and Albert Kesselring continued their raids. Kesselring launched a single, large flight on Kent, spurring a dogfight that involved more than 200 planes. Sperrle, on the other hand, went with a strategy of multiple smaller attacks across a 100-mile front in the south and southwest. In the wake of the previous afternoon's debacle, he intended to minimize his own losses while forcing the RAF into the air, and thus into danger. Sperrle gambled that Fighter Command would be unable to intercept all of the many simultaneous raids. As had been the case the day before, the RAF was indeed sorely challenged. Many Luftwaffe planes skirted Dowding's defensive shield and blitzed British targets.

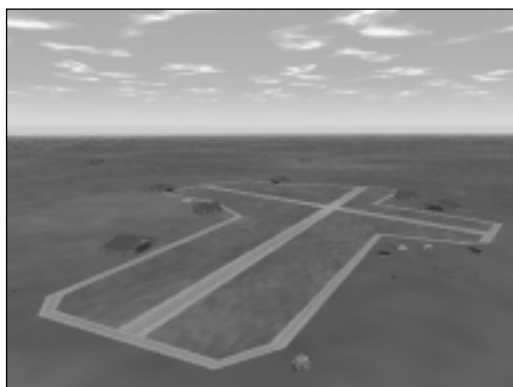

A tempting target

The following morning, August 15, started innocuously enough, but by mid-day the action had heated up. In southern England, the Luftwaffe pummeled the British. They shuttled bombers continuously back and forth across the Channel, their target the network of RAF bases. At any given time, Fighter Command planes were outnumbered in the air by as many as 20 to 1. Bombs rained down on the airfields, burning hangars, lighting up runways, and destroying precious British fighters before they could even get off the ground. The toll in both men and planes was heavy.

WHY YOU'RE HERE

In northern areas, in contrast, it was the Luftwaffe that took the beating. Effective resistance in the south during recent weeks had led German High Command to believe that the RAF had committed all of its fighter planes to the defense of the south and east. Göring therefore reasoned that he could send Luftflotte 5 from Norway to attack the north with relative impunity. Unbeknownst to him, however, Fighter Command had maintained a small force in the north to defend against just such a raid—despite heavy pressure, Dowding had insisted on this point. He frequently shuffled battle-weary squadrons to the area for a brief respite before returning them to the main field of combat. By that mid-August day, the men in the north were ready for a fight.

Air Fleet 5 was tracked by radar for an hour before it even reached the English coast, and Fighter Command was waiting for it when it arrived. (Due to a navigational mix-up, the main force of Luftflotte 5 had flown too close to its decoy flight, making both detection and interception much easier.) The RAF dove on the Air Fleet from out of the sun and quickly scattered the flight of escorts. The formation of bombers, now unprotected, was decimated. Most jettisoned their bombs before reaching their intended targets. Fighter Command's force of Hurricanes and Spitfires splashed nearly 30 Luftwaffe planes without losing a single craft of its own.

The day saw the heaviest fighting of the entire battle. German pilots later dubbed it "Black Thursday." Altogether, the German air force flew more than 2,000 sorties and British Fighter Command just under half that number. Losses were withering on both sides—scores of Luftwaffe fighters and bombers against more than two dozen RAF fighters, not to mention the pilots dead or captured. For the Germans, the day was particularly grievous. The Luftwaffe had destroyed no vital targets, had discovered no weak northern link in the fighter defense chain, and had been dealt a staggering defeat to one of its mighty Air Fleets. This was the first and only mass attack in daylight hours that Luftflotte 5 ever made, and the only major assault it attempted on Great Britain.



THE BATTLE CONTINUES

In the days to come, Göring grew increasingly frustrated. Despite an astounding rate of attrition, the RAF showed no sign of caving in. Fighter Command continued to mount resistance in the skies. According to the Reichsmarschall's own calculations, the RAF should have had fewer than 150 fighters left. (In fact, while the supply was certainly dwindling, it was nowhere near this level.) With each day that the RAF clung to life, the proposed timetable for Operation Sea Lion broke down a little further.

In anger, Göring berated the commanders of his Luftflotten. Little did he realize that his own intelligence service was partially at fault; their reports failed to differentiate between Fighter Command stations and those used by the other services, like Coastal Command. As a result, the Luftwaffe spent much time and effort bombing minor—sometimes even inactive—airfields. German intelligence also mistook the functions of a surprising number of British factories; several vital and highly vulnerable installations remained untouched throughout the battle, while the Luftwaffe instead set their sights on buildings only tangential to the war effort.

Göring's task was further complicated by the system of individual and independent Air Fleets—the lack of communication between the different Luftflotten caused untold confusion. Furthermore, pilot claims inadvertently exaggerated the number of downed enemy planes. Göring's estimates of enemy strength, based primarily on participants' accounts, were thus inherently flawed.

As August progressed, the weather deteriorated, forcing the intermittent suspension of full-scale attacks. In 1940, instrument flying, while not entirely out of the question, was both tricky and extremely dangerous. Heavy clouds between August 19 and 23 kept most flights from departing and let ground crews catch up on their repairs, pilots on their sleep. The break in the action also allowed commanders to reassess the course of battle. Some activity persisted—the Luftwaffe, after all, wanted to keep the pressure squarely on the RAF—but after the most recent spate, the action seemed to the English blessedly light.



The RAF had begun to feel the acute strain of battle. The problem was not a lack of aircraft, but the lack of trained pilots to fly them. British airmen were pushing themselves to the breaking point. The men were on constant alert. Pilots barely had time to eat between sorties, and they slept in their flight gear, ready to scramble at a moment's notice. Since August 8, almost a hundred Fighter Command pilots had died, and many more lay wounded in hospitals. Even after shortening flight school and recruiting volunteers from other countries, Fighter Command still had trouble putting men into its machines. On top of it all, the Royal Navy had requested and received (albeit grudgingly) standing patrols. Unlike Göring, who could choose to rest his men, Dowding was forced to put his patrols up each and every day. During the current lull, he stood down as many men as possible while maintaining adequate defensive measures. He also shuttled his most severely fatigued pilots northward to recuperate.

Göring used the respite to retool his strategy. He removed the vulnerable Stuka from front-line action and assigned Bf109 escorts to accompany all flights of Bf110s. In response to recent losses, he also instituted a new policy limiting the number of commissioned officers who could fly in a bomber at any given time.

As soon as the weather cleared, the Luftwaffe again pressed its advantage. It kept the airfields of southeastern England under constant bombardment. Kenley, Biggin Hill, Hornchurch and others hunkered down against the attacks. Manston, the most heavily bombed of all British bases, suffered through multiple raids. The Luftwaffe also took great interest in Eastchurch, one of Coastal Command's stations.

Any fighter losses were by now critical to Great Britain. The RAF needed every plane it could muster; its aircraft were always outnumbered in the sky. Twelve Hurricanes or Spitfires might meet a force of up to 40 bombers and their attendant escort of a hundred or more fighters. In desperation, British forces would often split into two groups—one to distract the escort, the other to take on the bombers—but there were always more than enough enemy fighters to parry both. The noose was beginning to tighten. Hitler scheduled a September 21 launch date for Operation Sea Lion.



The Luftwaffe claims yet another victim.

RAF losses continued to mount, at times now even surpassing Luftwaffe totals. On the final day of August alone, Fighter Command lost close to 40 planes—its highest total ever. Not surprisingly, by the first week of September, RAF fighter reserves were at their lowest level. Still, the British met the Luftwaffe's attacks.

Göring was beside himself. England's supply of fighters seemed limitless. Luftwaffe pilot claims indicated that the RAF had lost well over a thousand planes, nearly all of them fighters. Even allowing for a few inaccuracies, the Reichsmarschall felt the RAF should have been overcome by such staggering losses. What Göring didn't know was that Great Britain had one of the best programs for pillaging parts from dead planes—including German wrecks. Furthermore, the country's aircraft production never once fell behind schedule that summer or fall. No Fighter Command squadron had a full complement of planes, but the service somehow clung to life.

The most grievous concern to the RAF continued to be the supply of pilots. As far back as July, following the loss of more than 80 squadron and flight commanders in the Battle of France, Fighter Command had felt a shortage of qualified flyers. By the start of August, only about half of Dowding's pilots had any combat experience, and by mid-August the scores of dead and injured airmen far outnumbered their replacements. In the eleven days between August 8 and 18, more than 150 Fighter Command pilots were knocked out of battle. Training programs covered not even a third that number. Across the Channel, the shortage was less acute. Germany, long a country fascinated by aviation, still had a large reserve of skilled civilian pilots from which to draw.

LONDON

When Göring had launched Adlerangriff, he had given his pilots permission to bomb at will any target, with the exception of London. Hitler wished to delay for now an assault on the city, and so the bombings of August encircled the capital but left it untouched. Paradoxically, in England there were a number of people who actually wished the Germans to turn their attentions toward London—Prime Minister Winston Churchill, for one. He hoped that an attack on the British capital would draw the United States into the war. Another was Air Chief Marshal Dowding, who believed that the bombardment of London would divert the Luftwaffe from his fighter bases and give them a much-needed respite.

On the night of August 24, Luftwaffe bombers set their sights on the oil storage tanks at Thameshaven, only 15 miles from London. The planes were to fly in blind on the suburb, following the Thames Estuary in lieu of other directional aids. This decision proved a fateful one; in the clouds, one of the bombers strayed out of formation and inadvertently continued too far westward before dropping its payload. As it happened, the aircraft had drifted over the heart of London. Damage from the errant raid was restricted primarily to residential areas. No more bombs fell on London that night. The crew of the lost bomber was severely reprimanded for its navigational error, and Hitler reiterated his ban on targeting the capital city.

In the aftermath of the attack, Churchill ordered the RAF to retaliate with a raid on Berlin. Massive formations of bombers set out on the night of August 25 for the German capital, as they did on three of the next four nights. Their bomb loads were invariably light, since each aircraft was already weighted down with extra fuel, and the raids caused scant damage either to the suburbs or the city proper. The impact on the morale of German citizens, though, was devastating. Their Führer had intimated that the war was almost won, but now British bombers rumbled in the skies near the capital.

Bombing Berlin got the reaction that Churchill and Dowding wanted; on August 30, Hitler met with his Reichsmarschall and withdrew the earlier ban on attacking London. The German leader acted not merely out of revenge; he thought that a massive assault on the capital city would demoralize the English people and throw all of Great Britain into immediate and utter administrative chaos. Surrender, the Führer believed, would follow in a matter of days. Hitler was also convinced that bombarding the capital would be a healing tonic for the growing frustration of Luftwaffe pilots, and he suspected that they could soon polish off the RAF. On this, Feldmarschall Albert Kesselring agreed.

WHY YOU'RE HERE

Amidst the cries for retaliation on London, however, there was a single voice of dissent—that of Feldmarschall Hugo Sperrle. Sperrle felt that the Luftwaffe should continue on its current course of multiple smaller forays that had so dearly taxed Fighter Command to this point. A change in strategy now, he argued, could only help the RAF. His warnings went unheeded. Göring traveled immediately to France and took direct command of the Luftwaffe forces stationed there, in preparation for the bombardment of the capital.

Nothing in the air on September 7 hinted at the Luftwaffe’s change of focus. There were the usual early morning reconnaissance missions, followed by a pause in air traffic. Later in the day, multiple Luftwaffe flights approached from across the Channel, and Dowding sent his Fighter Command aloft to patrol the same airfields that had for so long been under attack. The men waited and watched. Nothing happened. Soon Fighter Command realized that the separate strikes were moving in from different directions and at different times, but on the same target: London. None of Dowding’s men was in position to head them off.

Wave after wave of bombers thundered overhead and let their bombs drop on the city below. The ground shook with the force of the explosions. Buildings crumbled, and factories collapsed. Much of London was ablaze by the time Fighter Command arrived. Although Dowding’s men gave chase to the Luftwaffe raiders, they claimed only a handful of bombers. Later that evening, in the darkness, the Luftwaffe returned with full fuel tanks and fresh payloads to strike again. More than 300 English civilians died in London that night. Nearly 150 more perished in the nearby suburbs, and over 1300 were badly injured. Thus began the Luftwaffe’s onslaught on London. Many hundreds of civilians died over the following weeks.



A pair of Me109s soars high over Great Britain during a daylight raid.

The daily fury of the bombing raids clearly seemed to indicate that the end was near—similar brutal attacks on the civilian population had preceded Germany’s other forced occupations. Moreover, despite England’s hopes, the United States still refused to lend military aid. The British believed that the German invasion was close at hand. But while the Führer’s newfound obsession with London traumatized the civilian population, it gave Fighter Command just the respite it needed. With the Luftwaffe’s attention focused primarily on the capital city, the RAF could repair bases, rest weary pilots, and train a sufficient number of new recruits to fly British warplanes. The interception of German aircraft also became much easier; pilots knew where the enemy was headed on every raid. Fighter Command—indeed the entire air defense system—had once been on the verge of collapse. Now it was on the rebound, and with it the nation’s spirits.

German morale, conversely, was steadily sinking. Nothing had prepared the country for a long-distance war of attrition with a truly powerful enemy. Their blitzkrieg offensives in Poland, Norway, France, and elsewhere had met with easy success, but conditions were different here. Lacking the ground support of previous encounters, Luftwaffe planes had to clear the way single-handedly for invasion forces. They were unprepared for the task. Nor were the Germans accustomed to resistance. For weeks on end, Luftwaffe pilots had been told that the RAF was all but extinct, yet Great Britain stubbornly refused to concede defeat. The battle had turned out to be more than the simple river crossing that Germany had expected.

THE CRISIS

September 15 signaled the turning of the tide. Mid-morning, Reichsmarschall Göring sent out an impressive array of aircraft on a daylight raid of London. Large formations of Bf109s and Dorniers linked up over the French coast and proceeded toward the city en masse. Their number and strength easily outmatched anything the English could muster. Göring didn’t count on meeting much resistance. The sheer size of the flight, however, made it easy to pick up by radar, and the RAF tracked its progress from the very outset. Fighter Command ordered aloft a defensive force of Spitfires and Hurricanes—virtually every RAF fighter available was running intercept.



The two forces clashed over Great Britain. The drone of engines filled the air as scores of German aircraft powered toward London. Fearlessly, the RAF attacked the strike head-on, breaking it apart and leaving the bombers vulnerable. The Bf109 escort was shortly forced to turn back as fuel ran low. Most of the Dorniers, harassed from every angle, unloaded their munitions willy-nilly and fled the scene. Damage was scattered and minimal. Even several direct hits on Buckingham Palace had little impact—the bombs failed to detonate, and both the King and Queen were absent at the time.

After a calm of several hours, the Germans came roaring back, this time with even greater might, but with substantially the same results. The flight took nearly half an hour to form over the Channel, and British radar again monitored every move. A fighter force was waiting as the Luftwaffe crossed into England. For a second time that day, the two adversaries locked horns, and for a second time the RAF splintered the incoming formation. In the battle that ensued, the Bf109s (as before) had to break off their escort early or risk splashing into the Channel on the return trip. Though the undefended bombers gallantly continued toward their target, they soon dumped their payloads and turned tail in the face of an unrelenting defense.

The RAF downed 60 German planes that September day and lost fewer than half that number themselves. Within 48 hours, Hitler indefinitely postponed his planned invasion of Britain. England had withstood the threat and dealt Germany its first decisive defeat of the war. Thus came to a close the first exclusively aerial battle in world history.

“The gratitude of every home in our Island, in our Empire, and indeed throughout the world, except in the abodes of the guilty, goes out to the British airmen who, undaunted by odds, unwearied in their constant challenge and mortal danger, are turning the tide of world war by their prowess and devotion. Never in the field of human conflict was so much owed by so many to so few.” Winston Churchill, 20 August 1940



FORTRESS WITHOUT A ROOF

“Hitler built a fortress around Europe, but he forgot to put a roof on it.” Franklin Delano Roosevelt

Royal Air Force Bomber Command began night-time area bombing raids against Germany in 1940 and continued raids against German cities and coastal installations in France and the Low Countries. Attempts early in the war had convinced them that daylight raids with unescorted bombers were too costly. Imagine their disbelief when the Americans proposed just that.

The first units of the U.S. VIII Air Force arrived in Great Britain in the beginning of July, 1942. Bomber command was very enthusiastic about the arrival of the Americans, and provided much needed logistics and facilities for the fledgling force. Cooperation between the RAF and VIII AF commanders had produced the needed procedures for air traffic control, logistics support and multi-national escorts. The first major problem facing the VIII AF was the level of training of its crews. Due to the rapid expansion of the air force, units were filled out with half-trained crewmen. Many pilots had little or no formation flying experience, and many units had only flown together for a couple of weeks before deploying to England. Aerial gunnery standards were poor, with many gunners never having fired their guns in flight, let alone at an airborne target. The RAF provided critical training schools and equipment to the new American units, and within a few weeks, they were combat ready.

THESE MAD AMERICANS

Many senior American officers, including the AAF's commander, General H.H. Arnold, and the VIII AF commander General Carl A. Spaatz, were proponents of strategic bombing. They believed that limiting bombing to night missions would not lead to any long-term success against the German war machine; the inaccuracy of night attacks would limit their ability to cause lasting damage to industry and other military targets. They favored daylight raids against key targets, with enough aircraft to ensure destruction of the target facility, but accurate enough to avoid excessive collateral damage to civilian areas. The British and many U.S. senior commands were skeptical, to say the least.



Proponents of strategic bombardment believed that the defensive firepower of a large formation of B-17s flying in a tight formation could hold off enemy fighters, allowing the formation to hit their targets with the accuracy of “dropping pickles in a barrel.” It was their belief that a force of bombers could penetrate and attack strategic targets deep inside an enemy’s country while maintaining acceptable losses.

Every theater commander was pushing for more heavy bombers and more air power. Early plans did not call for an extended air campaign against Germany to begin until a cross-channel invasion was only a few months away, so the VIII AF could not count on any immediate major reinforcement. In fact, their first two heavy bombardment groups and four fighter groups were transferred in November 1942 to create the XII AF in North Africa. If strategic bombardment was going to work, the VIII AF had to prove the concept quickly.

The first B-17 raid occurred on August 17, 1942, against the marshaling yards in Rouen. The attack consisted of 12 B-17s, escorted by RAF Spitfires. The Germans did not intercept the attack, and damage to the target was disappointing. Raids on this scale continued through August, with the first interception taking place on August 21. In this case, a 12 plane raid was late to rendezvous with its escorts, requiring the fighters to return early. The Germans had been waiting for such an opportunity and attacked the formation with approximately 20 fighters. They were totally surprised by the volume and accuracy of the defensive fire and limited their attack to a lone straggler. This B-17 was heavily damaged, but made it back to England. The Germans lost a few aircraft.

The number of bombers slowly increased during the next couple of months, culminating in a 108 plane raid on the Fives-Lille Steel Works on October 9. Four bombers were lost, and about 30 were heavily damaged. According to initial claims, 56 German fighters were shot down, but this total was soon cut closer to 20. Bombing accuracy still needed improvement. Overall, the raid was deemed a success, but this was to be the largest raid for the next six months. Bad weather limited attacks through the remainder of October, and in November, the units assigned to the XII AF were withdrawn.



The results of these early raids were definitely mixed. However, they were good enough to justify additional equipment and time. Over the next six months, the VIII AF, with just four active Heavy Bombardment Groups, had to either prove the validity of strategic bombing or give up the concept.

During those next few months, attacks were mainly limited to targets in occupied France and Belgium, with an occasional raid to the fringes of Germany. The initial bombing runs on the submarine pens and yards yielded inadequate results to justify an average ten percent loss rate. This very high attrition (a percent loss near five was considered more acceptable) lowered the morale and effectiveness of the American bombing crews. Planes began dropping their payloads prior to reaching their target, to avoid the heavier flak zones. The B-17s started to fly as high as 25,000 feet, trying to avoid the deadly flak. This higher altitude reduced bombing accuracy, since the bombs scattered more on the way down. The reduced damage required multiple trips on the same target. This meant that, in the long run, more planes were lost on the same target.

The air forces learned many, sometimes painful, lessons from these early raids. Luftwaffe commanders learned to exploit the weaknesses of the American formations. The standard B-17 bombing formation always kept the lead squadron in the center of the group. As the first plane dropped its payload, the other planes would release afterwards. If the German pilots could destroy the lead planes or force them out of formation, the chances for the entire formation to hit the target were reduced. The Germans also learned to coordinate their attacks on bomber formations just minutes after the escorting P-47s and P-38s disengaged due to low fuel. The Luftwaffe had a higher success rate against American bombers without the protection of their “little friends.” While the results of the bombing attacks continued to be mixed, they were just successful enough to keep the concept alive. The most significant outcome was the increasing number of fighter units the Germans were using to oppose the attacks. If they were hurting the Germans, strategic bombing would continue.

WHY YOU'RE HERE



The limited success of the American campaign gave rise to a strategy called “around the clock bombing.” The British would use their Stirlings and Lancasters after sundown, while the VIII Air Force would head out as soon as the RAF returned. What the Allies also agreed on was the importance of coordination, in terms of flight paths, takeoffs, and landings, as well as military targets. This pattern created separate bombing periods, allowing the AAF to work independent of the RAF. The initial targets of priority that the Allies agreed upon were the German submarine yards and aircraft industries. The Allies felt that if they could crush a high percentage of these installations, Hitler’s war machine would slow down enough for them to choose more targets of opportunity. The next, obvious targets were the transportation routes, oil plants, and war industries.

SCHWEINFURT/REGENSBURG

As the Eighth Bomber Command grew in strength, it began to search for a target that could prove that daylight bombing was capable of inflicting significant damage to Germany’s war effort—with acceptable losses. On August 17, 1943, the anniversary of its first raid, the Eighth launched mission number 84. The Schweinfurt/Regensburg raid was to be costly proof.

During the 1930s, Schweinfurt had become the center of Germany’s ball-bearing industry. Plants there produced the high quality ball-bearings necessary for motorized vehicles, aircraft engines, and so forth. At the outbreak of the war, these three plants began producing over half of Germany’s war-time requirements, making this a prime industrial target. In 1938, a large aircraft factory was completed at Regensburg. At the time of its selection as a target, this factory was the single largest builder of Me 109s, producing approximately 300 to 400 aircraft a month. Eighth Bomber Command believed that the destruction of these two targets would have a major impact on Germany’s ability to continue the war.



The Plan

Eighth Bomber Command’s planners envisioned a simultaneous attack on the ball bearing plants of Schweinfurt and the Messerschmitt factory at Regensburg. They believed that this coordinated attack would force the Luftwaffe to split its forces between the two, thus reducing the losses to both attack groups. The Regensburg force, consisting of 146 B-17s, was scheduled to leave first, followed fifteen minutes later by the Schweinfurt strike, 230 B-17s. Upon completing its mission, the Regensburg force was to continue southward and land in North Africa, while the Schweinfurt force returned to England. To sow further confusion among the enemy, four diversionary raids were carried out against various targets, in hopes of drawing some attention away from the main attacks.

The Mission

The morning of August 17 found the bases of the Eighth blanketed with a heavy, low hanging cloud cover. The initial take-off time of 0545 was delayed one full hour. After the delay, the weather still wasn’t cooperating, but time was now crucial for the Regensburg group if they were to reach North Africa before dark. At 0715, the latest they could leave, the Regensburg group took off. Time wasn’t as crucial for the Schweinfurt group, and their departure was delayed by three and a half hours. This decision would have grave consequences for both groups.

The Regensburg force crossed the Dutch border around 1000. At this point, two fighter groups were supposed to meet them and provide escort to the German border—but only one made the rendezvous. The Luftwaffe, alerted of the raid by their radar, took full advantage of the mistake. They concentrated their attacks on the two rear groups, in particular the low squadron of the low group. The further the Fortresses pressed on into Germany—devoid of any escort—the worse the opposition became. Me 109s and Fw 190s attacked singly, in pairs, and in waves of four or more for the next 150 miles. Most of their attention was focused on the 100th Bomb Group (which became known as the Bloody 100th). Eventually, nine of their aircraft were destroyed.

WHY YOU'RE HERE



After the bombers passed Mannheim, the single-engine fighters—now low on fuel and ammunition—were replaced by twin-engine Me 110s and Ju88 night fighters, which continued to harass the group from the rear. After nearly one and a half hours of continuous battle, the enemy broke away and the bomber group neared Regensburg—having lost seventeen Flying Fortresses. Leaving the factory smoldering, the surviving bombers set course towards North Africa. They encountered little opposition, as the Germans hadn't anticipated that move. Another reason for the light opposition was that the Germans had become aware of another raid beginning to form over England. Around 1730, slightly over 11 hours since takeoff, the Regensburg planes landed in North Africa. They had lost an additional 7 planes en route.

The Schweinfurt group began taking off slightly after 1100, and they proceeded along the same route the earlier bombers had taken. The Luftwaffe, now fully alert after the Regensburg mission, had time to concentrate thirteen *Jagdgruppe* in and around the area. What they had prepared for was the returning Regensburg force, but instead, they intercepted the inbound Schweinfurt force. The failure of the escorts to make rendezvous with the bombers provided the Germans with a golden opportunity that they didn't let slip by. Beginning near Antwerp, the bomber group was attacked intermittently by roughly 200 aircraft—all the way to Schweinfurt and back. At the height of the engagement, the Schweinfurt group faced nine full *gruppen*, approximately 180 aircraft, compared to the three (60 aircraft) faced by the Regensburg raiders.

Switching tactics from the morning's fighting, the Germans attempted to eliminate the lead formations. They nearly succeeded. As before, they initially concentrated their efforts on the lower group, destroying nine of the 381st Bomb Group. The Luftwaffe followed quickly with vicious attacks on the lead group, the 91st Bomb Group. This resulted in another eight bombers going down in flames. While the lead groups suffered catastrophic losses, the rear bombers were totally unaware of the disaster taking place in front of them, and were taking only minimal losses. The German "golden rule" applied—attack the weakened groups.



During the final leg to Schweinfurt, the Luftwaffe's attacks began to subside, as many of its pilots were running low on fuel and ammunition. They had destroyed twenty-four bombers, compared to fourteen from the Regensburg force. The running battle had lasted approximately one hour and fifteen minutes. At 1453, the bombers began their bomb run, and six minutes later, Schweinfurt felt the first of many explosions. During their time over target and their return flight, a further twelve bombers were lost due to flak and additional interceptions. The early morning decision to separate the two bombing forces allowed the Germans to concentrate their fighter force against both, instead of separating them as the attack had been designed to do.

Conclusion

On the anniversary of Eighth Bomber Command's operations, they had dispatched a force of 376 bombers to Schweinfurt and Regensburg. Of those, 361 crossed into enemy territory. When the day was over, 60 bombers had been lost—the highest single mission loss to date—and another 162 suffered various degrees of damage. On the other hand, Germany lost only 27 aircraft. For the next six weeks, the Eighth Air Force's attacks were confined to French and Belgian coastal targets. The Schweinfurt/Regensburg mission was a clear victory for the Luftwaffe, but the question remained—did the bombing results justify the cost in aircraft and crews lost?

At Regensburg, the bombing results were remarkably good. Fully two-thirds of the workshops were damaged, and production halted for a few months. Approximately eight to ten weeks of production (800 to 1,000 aircraft) were lost as a direct result of this raid. Learning a lesson, the Germans dispersed production facilities into the surrounding countryside. On the other hand, the bombing results at Schweinfurt were less fruitful. The raid failed to inflict any serious, lasting damage. In fact, the raids gave the Germans a clear warning that their ball bearing plants were vulnerable. As a result, they undertook protective measures to strengthen the defenses at Schweinfurt and protect the valuable equipment located there. The Eighth would have to return to finish the job at Schweinfurt.

WHY YOU'RE HERE



The Schweinfurt/Regensburg raid destroyed the illusion of the self-protecting daylight bomber. American commanders learned that knocking Germany out of the war was going to be a tougher and longer job than they had previously anticipated. Furthermore, the need for a long-range escort fighter became apparent, for without it, any deep penetration raid would again result in heavy losses. The Eighth Air Force learned that it didn't possess sufficient bombing capacity to destroy two targets simultaneously. In October, the Eighth returned to Schweinfurt with its full might and damaged the plants heavily.

OPERATION ARGUMENT

In 1942, the Allies had reasoned that a cross-channel invasion wouldn't be feasible until the German Luftwaffe had been defeated. They assigned that task to the Eighth Air Force, and throughout 1943, the Eighth struggled to accomplish this goal. Despite their efforts, control of the skies was still in doubt at the beginning of 1944—which threatened the proposed invasion set for later that year.

In late February, however, the Allies took a major step toward ending the Luftwaffe's reign. In a series of raids, Operation Argument, the Eighth attacked all of Germany's aircraft industry. The plan for Operation Argument required the VIII AF to attack a series of critical Luftwaffe targets. This would, in theory, force the Luftwaffe to make their own maximum effort to protect these targets, allowing the VIII Fighter Command to engage them and destroy the Luftwaffe in the air. The following targets were selected:

- ④ The Erla *Maschinenwerke* at Leipzig, responsible for final assembly of one-third of all the Me 109s built (This same complex housed repair shops and assembly lines for both the Ju-88 and Ju-52.)
- ④ Messerschmitt plant at Wiener Neustadt
- ④ Messerschmitt plant at Regensburg



WHY YOU'RE HERE

- ④ The Central Germany Complex, which included aircraft production facilities at Oschersleben, Kassel, Warnemunde, Anklam, and Marienburg
- ④ The Eastern Germany Complex, consisting of facilities at Tutow, Poznan, Gdynia, Sorau, Cottbus, and Kresinki
- ④ Aircraft Plants at Brunswick, Gotha, Augsburg, Bernburg, Munich, and Budapest (these produced the Me 110, 210, and 410, plus the Ju-88 and 188.)
- ④ Approximately 18 other factories in 14 cities that produced engines for twin-engine fighters

The raids provoked an all-out response, which was exactly what the Eighth was hoping for. It was a costly week for both sides, but seriously affected the Luftwaffe's ability to defend Germany.

The attacks during "Big Week" deprived the Luftwaffe of many badly needed aircraft, but the initial damage estimates were wildly over-optimistic. The German dispersal program, a direct result of the raids in July and August of 1943, had had a cushioning effect. The decentralization of production limited the ability of the Allied attacks to hit critical industrial bottlenecks and forced the attackers to seek out a group of smaller, dispersed targets. German fighter production took a plunge after Big Week; the following month's total was less than half of that planned. This reduction was not permanent.

Another softening factor was that the bombs dropped by the VIII AF were too small to be capable of destroying the vital machine tools inside the factories. These were soon retrieved and reused. Fighter production returned to near pre-attack levels within months. During the six day operation, Eighth and Fifteenth Air Force bombers flew 3,300 sorties and dropped approximately 10,000 tons of bombs, at a cost to the Allied forces of over 220 bombers and 28 fighters. Afterward, the Luftwaffe was still capable of mounting a strong defense, but this operation forever altered the course of the air war in favor of the allies.



Big "B", MARCH 6, 1944

Assuming that they had struck a telling blow to the Luftwaffe during Operation Argument, the Allied air commanders wanted to keep up the pressure. They made a point of selecting targets that the Germans would be forced to defend in the air. It wasn't long before they decided to attack the biggest target of all—Berlin.

As a potential target, Berlin had many attractive qualities. Primary among these, the Eighth Air Force reasoned that the Germans would defend their capital with everything they had available. Drawing the Germans into combat would give the Eighth the opportunity to further the destruction of the Luftwaffe. As an added benefit, the city contained many strategic industrial targets, including a ball bearing plant, an aircraft engine plant, and an electrical equipment factory (to name just a few). Finally, the morale boost of bombing the Reich's capital would be tremendous. Berlin had been bombed several times by the RAF, but the Americans had not yet paid their first visit. That was about to change.

The raid was originally scheduled for March 3, but due to weather conditions, that sortie was scrubbed. On March 5, forecasters predicted acceptable conditions over Berlin for the next day. The stage was set. On March 6, 1944, Eighth Air Force Mission number 250 took off for Hitler's capital ('Big B'). This mission would prove to be the costliest of the war, but it showed that the Eighth could go anywhere it wanted to, and that no place in German territory was safe any longer.

The Plan

The plan for Mission number 250 called for a maximum effort involving nearly all the operational fighter and bomber groups of the Eighth Air Force—a total of 810 bombers and 796 fighters. The bombers were organized into three divisions, and each division was assigned a target. First division targeted the ball bearing works at Erkner, on the east side of Berlin. Second division drew the Daimler Benz engine plant at Genshagen, slightly south of Berlin. Third division set their sights on the electrical equipment plant at Klein Machnow, to the southeast. The Second's original target had been an aircraft plant at Oranienburg, but weather conditions had forced a change in plans.

Weather dictated that the raiders travel the most direct route, with only minor deviations to avoid known areas of heavier flak. The bombers were to follow the 52 degree, 37 minute line of latitude to a town called Celle, after which they were to turn east-southeast and head to a point slightly north of Magdeburg. There, the divisions were to split and make their way to their respective Initial Points, then complete their bomb runs. Afterwards, the First was to continue north, while the Second and Third turned westward in an attempt to leave the flak area quickly. All three bomb divisions were to link up northwest of Berlin and use the same route out as they had going in. During the return flight, the divisions were to fly line abreast, instead of the column formation used on entry. This simpler formation would make the job of the escort easier, by condensing the bombers into a group 20 miles wide by 30 miles long, instead of a column 1 mile wide by 94 miles long.

The bomber divisions were to be escorted by sixteen fighter groups from the VIII and IX Air Forces, as well as two R.A.F. squadrons. The plan had P-47s covering the bombers' outbound and homebound routes roughly as far as Brunswick and P-51s escorting them to the target area. P-38s would assume escort duty as the bombers left the target area. On paper, the plan seemed simple and sound, but whether it was going to work was another question entirely.

The Mission

At 0745 on the morning of March 6, lead elements of the First bomb division began taking off, followed by the Third and then the Second. As the bombers began to form up over England, German radar picked up the force and alerts brought their pilots to *Sitzbereitschaft*—cockpit readiness. After assembly, the bombers headed out. They formed a stream of aircraft almost 100 miles long—so long that after the First division crossed into the North Sea, around 1000, it was fully 40 minutes until the last plane was over the sea. (The lead division reached the Dutch border only a few minutes after the rear division had begun flying over the North Sea.) The first group of escorting fighters, P-47s, moved into place. Moments after the raid crossed the Dutch border, the Luftwaffe ordered the first of its units into the air. When the First crossed into Germany, they had already—unknowingly—deviated from the planned route.

WHY YOU'RE HERE



At 1130, German observation posts reported the enemy passing over the border. As the stream of bombers flew deeper into hostile territory, over a hundred German fighters began assembling over Lake Steinhuder. Ground control directed them towards the bombers. Slightly before noon they made contact near Lake Drummer. As a result of the first being off course, instead of intercepting the vanguard of the bombers, which were well protected, the German fighters found themselves engaging a group of relatively unprotected bombers. In the ensuing battle, which lasted approximately 25 minutes, a total of twenty B-17s and three escorting P-47s were destroyed—for a cost of twelve Fw 190s and Me 109s. The opening round was over, but even as this battle raged, German controllers were assembling another large attack formation.

The controllers had organized a large concentration of fighters comprised of Me 110s, Me 410s, and Me 109s near Magdeburg. Together with some additional aircraft, the group totalled 72 single-engine and 41 twin-engine planes. All the twin-engine fighters were equipped with rockets under their wings. The Me 109s had strict orders to protect the heavy fighters until they reached the bombers; then they were on their own. At 1230, this group received intercept instructions from ground control. It wasn't long before another great battle was underway.

The German fighters engaged the lead bombers approximately twenty miles north of Magdeburg. The 25 escorting P-51s positioned themselves to cover their bombers as best they could, but they were extremely outnumbered. Just as the Germans began their attack, a timely reinforcement of P-51s showed up and entered the fray immediately. The main battle lasted for a solid 25 minutes, with minor skirmishes continuing for another half hour. The German force was a much larger and more powerful one than in the prior engagement, but this time the escort was able to effectively blunt their attack. Only eight B-17s and four P-51s were lost. Conversely, the Germans suffered heavily—the heavy fighters in particular—with sixteen Me 110s and 410s lost and seven Fw 190s and Me 109s. The bombers continued toward Berlin.



Arriving over Berlin a little after 1300, the Allied bombers were met by the heaviest and most accurate flak concentrations they had seen to date, which destroyed some and damaged many more. Poor weather conditions at the targets prevented visual bombing. Unfortunately, by the time the crews realized this, it was too late to attempt radar bombing. As a result, the bombing results were poor, with most of the bombs falling on the wrong targets. Berlin residents finally received the All Clear at 1408, after the last bombers had turned away.

After completing their bomb runs, the bomber groups turned northwest to reform into their divisional formations for their journey home. Of course, the Luftwaffe wasn't done with them yet. While the stragglers were being attacked, ground controllers vectored in another one-hundred-plus aircraft for the last action of the day. Some of these aircraft were flying their second sortie, having participated in one or the other of the earlier engagements. At 1440, the last onslaught began, near the German-Dutch border.

Unlike in the previous two major attacks, the Germans did not have time to assemble into a large attack formation. The Luftwaffe fighters attacked in small groups from different sides. The escorting fighters again intervened efficiently. Between this attack and attrition during the withdrawal, an additional eighteen B-17s, one P-47, and one P-38 were lost. The Luftwaffe lost seven Me 109s and four Fw 190s for its participation. The first mission to Berlin officially came to an end at 1745, when the last bomber landed.

Conclusions

The mission to Berlin produced exactly the reaction that the Allied High Command had been hoping for—a strong defense from the Luftwaffe. As a result, the Eighth Air Force lost a total of 80 aircraft: 69 bombers and eleven fighters. Germany's losses amounted to 66 fighters. The Eighth's lost aircraft, though the highest number of any mission to date, were easily replaced. On the other hand, Germany had lost 46 pilots, either killed or wounded, who were irreplaceable. The Luftwaffe's training facilities had long since not been able to keep pace with their rate of loss, resulting in a steady decline of fighter strength. Furthermore, the pilots being turned out were inferior, due to their training being cut short as demand grew stronger.



Although the raid caused only minimal damage to the target areas, the Eighth had shown the world that they could strike anywhere in Germany at will. They returned to Berlin four more times that month, meeting substantially less resistance each time. The first mission to Berlin could be considered a pyrrhic victory for the Luftwaffe, but at that time, they could ill afford such victories. Overall, the mission allowed the Eighth Air Force to continue its main goal, the destruction of the Luftwaffe. By June 6, 1944, it was clearly evident they had accomplished that goal.

PREPARING FOR INVASION

In the months leading up to the invasion of Normandy, the Allied Air Forces found themselves filling a dual role. They had to both maintain the strategic bombardment of Germany, in order to keep the Luftwaffe suppressed, and attack the necessary targets to prepare for the invasion—Operation Overlord.

The Air Campaign Continues

The Allies' most important strategic targets for bombing during this period included V-1 launch sites and Germany's synthetic oil production facilities. The V-1 sites, code named NOBALL, were located in the Pas de Calais and the Low Countries. Attacks on these targets had several objectives. The first (and most obvious) was the destruction of the V-1 sites themselves. This would help to slow or stop the V-1 attacks on England. The Allies also feared that the Germans might begin to target the V-1s on staging areas and ports in southern England—those required for the invasion. (The Germans never used this tactic.) Attacks on any target in the Calais area also served to mislead the Germans that the invasion would occur there, instead of the real target area in Normandy. Finally, the weather over these V-1 targets was usually better than over target areas in Germany. This allowed them to use NOBALL targets as secondary targets if the weather was too bad for an attack into Germany.



By 1944, General Doolittle, the new VIII AF commander, was opposed to stopping the strategic bombardment of Germany just to prepare for the invasion. Cloaking the attacks against oil targets under the pretext of destroying the Luftwaffe, General Doolittle balanced attacks on the oil industry in Germany with the required attacks on invasion targets in France. The German oil industry had long been a favored target of strategic bombardment proponents. There were several reasons it had not previously become a target. Germany's main source of oil was the Romanian oil fields at Ploesti; over 75% of German oil needs were met with synthetic petroleum. The processing and production centers for the synthetic industry were scattered, and combat strength in 1943 did not allow for the type of effort needed to attack such a dispersed target. Direct attacks against Ploesti proved to be much too costly. Early 1944 was the first real opportunity the Allies had for strategic attacks against the oil industry.

This series of attacks, including a record 1,282 bomber raid on May 28, saw some of the most critical air battles of the war. Attacks by Luftwaffe fighters were pressed home, with massed attack following mass attack. Bomber losses were heavy, but these missions resulted in some of the best bomb performances of the war. In the 12 May attack on oil targets in the Leipzig area, the 385th Bomb Group dropped 97 percent of their loads within 2,000 yards of the aim point—an outstanding success by the standards of the time. These attacks had two positive results: the Luftwaffe continued to lose precious aircraft and pilots in the defense of Germany, and German oil production was reduced in the critical months of the invasion.

Preparing for Overlord

The success of Operation Overlord depended on three key actions. First, the Allied air forces had to gain air superiority to allow the initial assault and build-up to proceed unimpeded by enemy air attack. Second, the rail and transportation network in France and Germany had to be destroyed in order to isolate the lodgment area and prevent German supplies and reinforcements from reaching the combat area. The third and in many ways most important objective was to maintain the element of surprise for the assault.

WHY YOU'RE HERE



The battle for air superiority had been in progress for over a year, and by May of 1944, the Allies had succeeded. The Luftwaffe was a mere shell of its former self, and it was totally committed to defending the Fatherland against Allied bombing missions. German tactical units in France were desperate for pilots, aircraft, and fuel. As a measure of Allied air domination, the Luftwaffe launched a grand total of two sorties on D-Day.

The second part of the air plan, the interdiction plan, began in March, when all Allied air forces were placed under the command of General Eisenhower. This change of command responsibility did not sit well with the American air commanders, who felt that diverting their bombers to interdiction missions was a waste of their ability. As it turns out, it was critical. The interdiction campaign started in March, with attacks on marshaling yards located throughout northern France and a continual reconnaissance of enemy movements. In April, these missions were expanded to include attacks on locomotives, barges, and vehicle convoys—to disrupt the transportation systems. These attacks continued until the last week of May, when all bridges over the Seine between Paris and Rouen were targeted. These were destroyed by D-Day. In addition, permanent airfield installations within a 150-mile radius of the beachheads were attacked. The destruction of maintenance and repair facilities was followed by attacks on hangars and runway surfaces. The German radar network along the French coast between Dunkirk and Brest was also attacked, to prevent early detection of the invasion fleet.

The deceptive part of the air plan required that for every target attacked within the invasion area, two targets must be struck outside the assault area—an attempt to cover the Allies' real intention. Air crews did not know where the invasion area would be; they were aware only of their target, not of its relative importance in the invasion plan. These diversionary attacks placed a lot of extra strain on the men and planes of the Allied air forces, but helped insure the successful invasion of Fortress Europe.



SUPPORTING THE INVASION

The interdiction campaign continued after D-Day, delaying German reinforcements and causing attrition in combat units before they could reach the battle area. The *Wehrmacht* was forced to move its panzer divisions by road instead of rail, resulting not only in delays, but severe wear and tear on the combat vehicles. Divisions were forced to move only by night, and to remain scattered along the road. Combat formations are only effective if they can be committed in a body and with their supporting arms; the interdiction campaign prevented this and allowed the Allied armies to win the build-up race.

During June and July, Allied aircraft flew close air support and interdiction missions constantly over Normandy. A majority of the VIII and IX Air Forces were dedicated to close air support and interdiction missions. There were over 2,000 sorties per day against transportation routes, convoys, supply lines, tank farms, railways, and bridges. Many of the German communications installations were destroyed or disrupted, causing havoc throughout the *Wehrmacht*. The VIII and IX Air Forces played an important role in the Allies' rapid advancement through France.

During this period, General Bradley and Field Marshal Montgomery both attempted to use the heavy bombers as artillery, trying to blast the German front line with carpet bombing. The tactic had mixed results. On the positive side, bombardment was devastating to any unit under it, destroying combat vehicles and rendering most units combat ineffective. On the other hand, on several occasions the bombers were off target, accidentally hitting friendly units, causing tremendous casualties. In addition, the bombardment devastated the ground so much that it slowed any advance through it almost as much as the defenders would have. The carpet bombing technique was not repeated after the U.S. breakout.

Throughout the period, General Doolittle continued to launch as many strategic missions as possible into Germany. The main targets continued to be the oil industry and Luftwaffe production facilities.

WHY YOU'RE HERE

Just a week after D-Day, the Germans launched the first V-2 rockets against London. This vengeance weapon was perhaps the one invention the Allies feared the most—not because of the damage it could do, but the potential it would have once perfected. The Allied Air Command frantically switched priority to any factory that produced these rockets. Fighters returning home from escorting missions often deviated from their flight path to unload any extra ammo on any installation that could or would launch V-2s.

OPERATION BODENPLATTE

Adolf Galland, head of the Luftwaffe fighter force, had watch his fighters suffer grievous losses to enemy incursions throughout 1944. In the first four months alone, Germany lost over 1,000 pilots, including many irreplaceable veterans. Galland's report that summer stated, "The time has arrived when our weapon is in sight of collapse." In June, Galland watched his fighter ranks further thinned when he attempted to contest the Allies' landing in Normandy. By fall, Galland faced the daunting prospect that the Luftwaffe was all but absent from the skies above Europe. However, as he observed the steady decline of his fighter force, he learned one valuable lesson—individual or small group attacks against the large escorted bomber formations proved fruitless. Reasonable results were achieved only when significant numbers could establish some semblance of numerical parity.

Galland devised a plan known as *Der Grosse Schlag*, the "Great Blow." His design was to cripple the bomber force of the Eighth in a single, one-day, massive retaliation. It would employ 1,000 fighters to storm the bombers of a single mission headed into Germany. Furthermore, 400 fighters would fly a second sortie, destroying any previously damaged bombers. Additionally, approximately 100 night fighters would be positioned to annihilate any cripples attempting to make it to Switzerland. Galland believed that he could destroy upwards of 300 bombers, and he was prepared to accept an even exchange rate of up to 400 fighters. He hoped that such a blow would force a temporary halt to the daylight bombing offensive against Germany. Luftwaffe Command allowed Galland to build a large reserve, but they had other ideas for such a force—support for their upcoming winter offensive. Galland's plan was never realized, as a series of setbacks in November and December decimated the reserve he had built up. These setbacks, however, did not deter command's decision to use the remaining fighters in support of the planned *Wach am Rhine* ground offensive. As the panzers ground to a halt outside Bastonge, the German air force prepared for one last desperate gasp. The stage was set for the Luftwaffe's death throes.

The Objective & Plan

The Luftwaffe's overall objective was to destroy the Allied air power based in Europe and regain control of the airspace over western Europe. Afterwards, that would allow them time to create a strong defense against the daylight bomber incursions. The plan called for a series of simultaneous attacks on Allied airfields located in Belgium, Holland, and France early in the morning of January 1. Their hope was to catch and destroy a majority of the Allies' planes on the ground. The operation involved every available unit, with the exception of the JG300 and JG301. Altogether, 900 German aircraft in 33 Gruppen were involved in the last major Luftwaffe offensive.

The Mission

On the morning of the first, German planes began to take off and proceed towards their designated targets. All German flak batteries were notified of the operation and had strict orders not to fire during specific times, to allow the Luftwaffe to pass unhindered. However, an unexpected ground mist and some delays in forming resulted in revised timings. Unfortunately, these new times were not communicated to the anti-aircraft batteries, resulting in catastrophe. The Germans lost upwards of a hundred aircraft to their own gunners. The remaining aircraft proceeded to their targets.

The first attacks began shortly after 0900, with the last to begin just before 1000. Navigational error resulted in some of the targeted airdromes being missed or attacked by only a few aircraft. In addition, poor aerial reconnaissance led to strong fighter attacks on airfields which contained only a few aircraft. Furthermore, some aircraft formed up with the wrong groups, consequently upsetting the balance of each planned attack.

Despite the problems and confusion, those attacks which found their marks obtained varying degrees of surprise. Initially, the Allies' response was slow, but it quickly erupted like a stirred hornets' nest. The ensuing battles above the airfields were intense and bloody. At Eindhoven, the Germans managed one of its most successful attacks, destroying the equivalent of a wing of Typhoons and several Spitfires. The Allies also suffered roughly 25 pilots killed during this attack. On the other hand, the raid on Le Culot was a total fiasco. Instead of attacking Le Culot, a navigational error resulted in the Germans striking the airdrome at Melsbroek. The error cost them dearly. After the day was over, only 30 aircraft returned out of the 55 aircraft that had left that morning. A total of 23 pilots were killed or captured. All of the other attacks had similar results, some with success and others failure.

Conclusion

The attacks on January 1 had varying degrees of success. Of the nineteen airfields struck, only two could be called complete successes—Eindhoven and Evere. Meanwhile, Le Culot was total failure. The remaining sixteen attacks resulted in some success and some minor damage.

Overall the Allies were barely affected by the operation. Although they had lost close to 500 aircraft, both on the ground and in the air, the air forces didn't flinch. Within two weeks, they had replaced their losses. Furthermore, since a majority of the aircraft lost were on the ground, few air crews were lost, resulting in little to no effect on the units' state of readiness. On the other hand, the German losses were prohibitive. More than 200 pilots were lost, including many of the few remaining experienced combat leaders. An estimated 300 planes were destroyed, approximately 30 percent of the total aircraft involved. After that day, the Allies encountered only token resistance from the once mighty Luftwaffe. Operation *Bodenplatte* had been their swan song.

THE FALL OF THE THIRD REICH

The war of attrition was wearing down the once mighty Luftwaffe. American war production was at an all time high. The VIII and IX Air Forces were reinforced at a rate more than twice their attrition rate. Green pilots were getting front-line action side by side with veteran aces. Most of the American sorties moved in large formations, so the Luftwaffe could never muster enough strength to even the odds, even when time allowed. The Luftwaffe, on the other hand, had more planes than pilots. Most of the German planes were waiting for an experienced (or even inexperienced) pilot to fly them. The war on the Russian front, in combination with the Allied march through France, crippled pilot training time. Most of the Luftwaffe cadets had only enough time to sit in the cockpit for eight to twenty hours before they were engaged in a dogfight. The only training concept the Luftwaffe could create was, "real training with live ammo and deadly opponents." The German army had become so used to the idea of having no air support that they had a simple saying, "If the plane is silver or blue, it is an Allied plane. If it is invisible, it is ours."

CONCLUSION

The nature of aerial combat changed in the six years of war as much as it had in the twenty years between the two world wars. The successes and failures of the various air forces are still being debated more than fifty years later. Let's take a brief look at the various strategies used and evaluate their success.

AREA BOMBING

The area bombing of enemy population centers was intended to break the morale of the enemy's population, forcing them to surrender. It didn't work. The bombing of English cities only hardened the resolve of the British population. At no time did the British consider surrendering to stop the bombardment. Twice, in the Battle of Britain and during the V weapon *Blitz*, the Nazi insistence on terror bombing crippled their war effort. In 1940, it relieved the pressure on the RAF and allowed it to rebuild its airfields and support structure. In 1944, a V weapon bombardment of the staging and port facilities—let alone the Normandy beachhead itself—could have lengthened the war or even stopped or postponed the invasion. The British raids on German cities had much the same result. Instead of weakening the German resolve, it actually hardened the German will to fight on.

STRATEGIC BOMBING

The goal of strategic bombardment was to destroy industrial capability and render the enemy unable to supply and support its military. In other words, to bomb them into submission. When viewed from this perspective, strategic bombing failed.

The U.S. Strategic Bombing Survey, conducted after the war, came to some startling conclusions. The ability of German industry to recover from bomb damage had been vastly underestimated during the war. The survey also indicated that the German dispersal program was probably responsible for more lost production than actual bomb damage to factories. The attacks on German industry in 1942 and 1943 did not produce a lasting effect on German production. Military production peaked in 1944, then fell sharply as the production areas were occupied by ground forces. In retrospect, the technical abilities of the aircraft available were not sufficient for a successful strategic bombing campaign. In fact, it would take another fifty years before a strategic bombing campaign was successful.



This said, the strategic bombing campaign was critical in winning the war, but not the way it was planned. The constant air attacks forced the Luftwaffe to fight a losing, defensive battle of attrition and prevented the Germans from fighting the tactical air battle in support of their ground forces. The overwhelming Allied industrial capacity allowed them to replace losses much faster than the Germans. This sealed the fate of the Third Reich.

THE INTERDICTION CAMPAIGN

The U.S. Strategic Bombing Survey also made some other discoveries. Over three-fourths of the bomb tonnage dropped on occupied Europe was dropped after D-Day. Of the targets bombed, the strike on the transportation and oil industry produced the greatest strain on the German economy. The interdiction campaign waged throughout 1944 crippled the ability of the Wehrmacht to fight the ground war. This often-overlooked aspect of the war was probably the greatest contribution to victory in Europe.

At the end of the war, Feldmarschall Von Rundstedt, German commander in the West, stated that three factors defeated Hitler. The first was Allied air supremacy over Europe, which made movement during the day almost impossible. The second was the lack of fuel needed to fly their planes or move their panzer divisions. The third was the destruction of all the vital railways and bridges, so that it became impossible to supply or reinforce the front lines. All three of these were results of the Allies' domination during the European Air War.



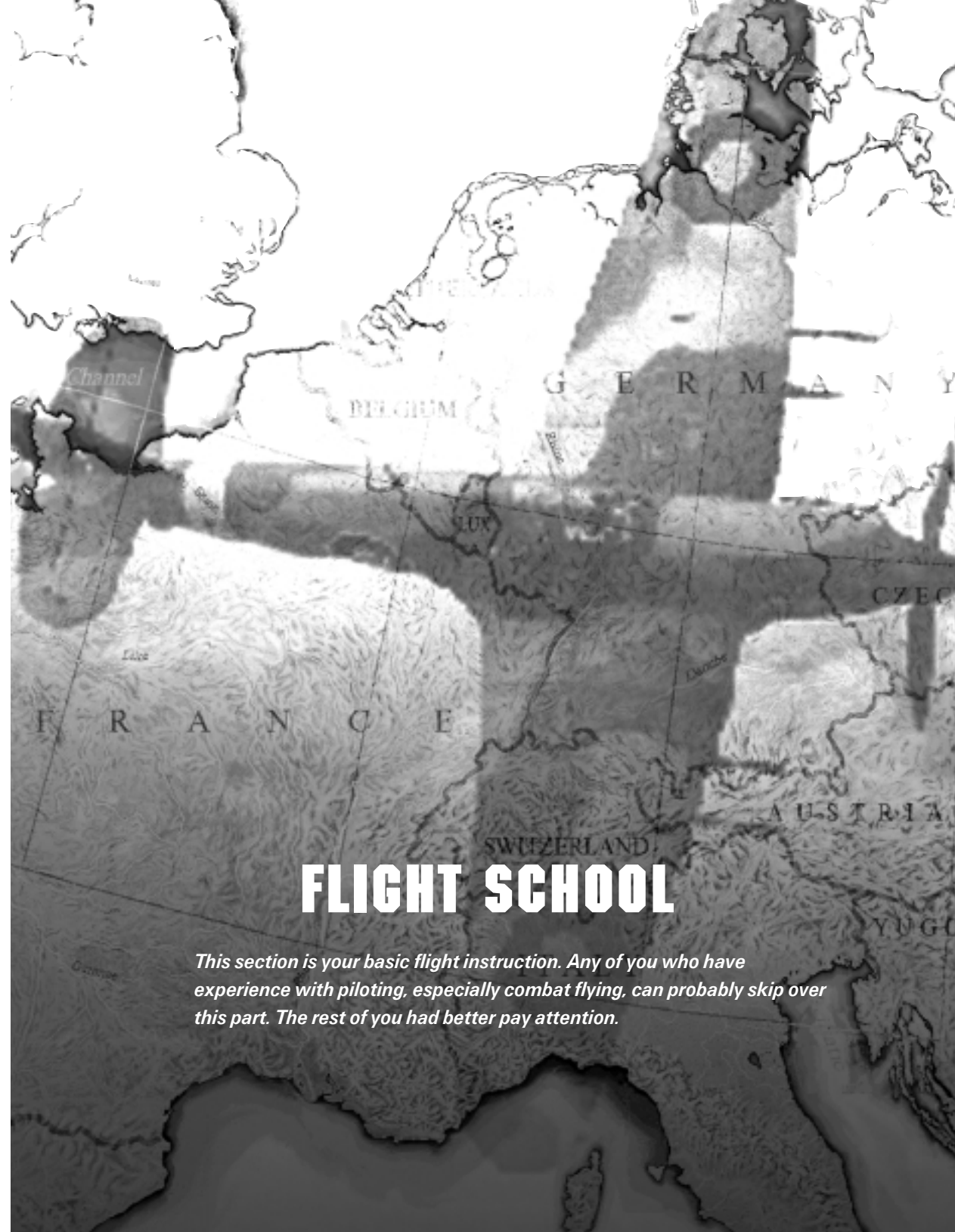

FLIGHT SCHOOL

This section is your basic flight instruction. Any of you who have experience with piloting, especially combat flying, can probably skip over this part. The rest of you had better pay attention.

THE BASICS

Despite the differences in design between the several models of aircraft included in *European Air War* (these differences are discussed in detail in the subsection entitled *The Cockpits*), there are some features of flight that remain consistent across the board. It is your responsibility as a pilot to familiarize yourself with the essential basics of flight before you take control of any aircraft.

Those of you who think you know something about flying might find some of these lessons overly simplified. Read them anyway. You won't have this book with you in combat, and your life *will* depend on knowing more and being more skilled than your enemy. Besides, you might learn something.

ESSENTIAL AERODYNAMICS

This is the physics lecture. Literally hundreds of green pilots have lost their lives because they *thought* they knew how their plane would react. The only way (let us stress that—the *only* way) to really be in control of your aircraft is to understand the forces acting on it and the way the control surfaces manipulate those forces. You don't need to memorize Bernoulli's equation, but you'd better understand what it means for your wings. The pilot who has the aerodynamics ingrained in his head can overcome virtually any enemy, including the "ace-killer," an uncontrolled spin.

The Four Forces and Torque

There are four basic physical forces that you have to worry about when you're flying a propeller-driven aircraft. Most textbooks stop at those, but there's more; if you don't know about torque, you'll end up like the many inexperienced pilots whose careers (and, too often, their lives) were ended trying to land without taking the torque of their plane into account.

1) **Gravity** is easy to understand; you deal with it every day. Your plane and everything in it are attracted to the surface of the earth. The more weight (technically, mass) on your plane, the greater the attraction. If there were no other forces acting on your plane, gravity would pull it to the ground and keep it there.

- 2) **Drag** would limit how fast you would fall. In simple terms, drag is the resistance the air offers to anything trying to move through it. A moving aircraft with no force impelling it would quickly slow down and stop because of the drag of the air around it.
- 3) **Thrust** is how you force your plane through all that drag. The spinning propeller pushes air backward, which action results in Newton's equal and opposite reaction—a forward motion of the entire aircraft. In a jet engine, air is taken in through the front (the "intake") and the oxygen in that air is burned with fuel, causing exhaust. This exhaust leaves the rear of the engine at tremendous speed, which causes the same sort of forward thrust as a spinning propeller, but much more of it.
- 4) **Lift** is what keeps you in the air. The aircraft's wings are designed to take advantage of a side effect of the law of conservation of energy. The curvature of the wing causes air to move faster going over the top of the wing than it does going under. The side effect is that this faster-moving air has a lower pressure than the slower air (the pressure is determined using Bernoulli's equation), and the difference in pressure between the bottom and top surfaces of the wing lifts it. When the lift on both wings is great enough, the plane is held aloft. With lift and thrust both working to counteract nature's attempts to keep your plane from moving, it flies. The angle at which the wings meet the airflow—the "angle of attack"—affects the amount of lift produced.

Bernoulli's equation, as applied to the airflow around a wing (in case you really want to know) is:

$$P + \frac{1}{2}\rho v^2 + \rho g y = K$$

That is, for any particular volume of air, the sum of its pressure (P), kinetic energy ($\frac{1}{2}\rho v^2$), and potential energy ($\rho g y$) stays constant (= K). Meaning, roughly, that the faster a volume of air moves, the lower its pressure.

5) **Torque** in an aircraft is roll caused by a radial engine. These engines rotate in only one direction, and that direction coincides with the roll axis of the plane. Some of the torque generated by the engine's rotation is transferred to the body of the plane, which makes the plane try to rotate in the opposite direction as the engine (usually counterclockwise—the left wing tends downward). If the pilot does not compensate for this, the torque will cause the plane to roll. This is especially dangerous at low airspeeds and when landing.

The Three Axes

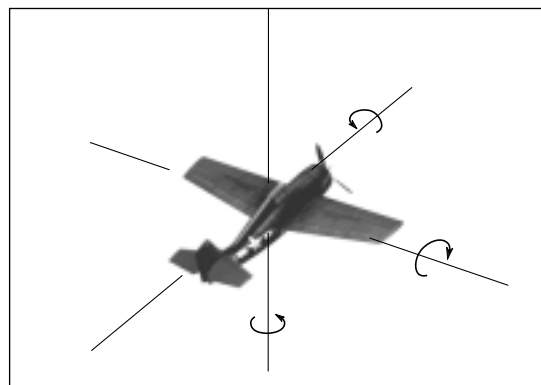

Axes of motion

An aircraft can move in an essentially unlimited number of directions. For simplicity, however, we use a system of reference based on three axes of motion. By design, these axes correspond to the three main types of aircraft motion that you can control.

- Ⓜ **Roll** is rotation of the plane around its length, also called the "parallel horizontal axis". What this means in simple terms is tipping the plane to the right or left.
- Ⓜ **Pitch** is rotation of the plane around its "transverse horizontal axis" (the line of the wings). That is, tilting the nose up and down.

- Ⓜ **Yaw** is rotation of the plane around its vertical axis. If you were looking at the top of the aircraft, moving the nose to the left or right (the tail would move in the opposite direction) would be yaw.

In short, *roll* tips the entire aircraft to the left or right, *pitch* pushes the nose of the craft up or down, and *yaw* swings the plane's nose to the left or right.

Control Surfaces

Manipulating these basic forces is how you control the movement of your plane. Your engine provides the thrust, thus you have control over thrust. Two of the forces—drag and lift—do not act on all parts of the plane equally. Aircraft designers have taken advantage of that fact to build in features that let you control the plane. These features are called the "control surfaces."

Elevators These are vertically-tilting sections of the horizontal part of the tail. Through drag, they affect the pitch of the plane. You control them with the forward and back movements of the stick. When the elevators are down (stick forward), the imbalance in the drag on the plane makes the nose tilt down. This is called "lessening the angle of attack," and it causes the plane to dive. Up elevators, conversely, tilt the nose up, and the plane climbs.

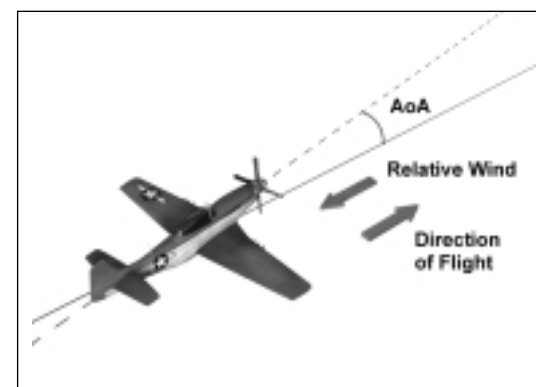

Angle of attack



Ailerons These are similar to the elevators, only they're on the wings. When you move the stick to either side, one aileron goes up and the other one goes down. This means that one wing gains some extra lift, and the other one gets more drag. The former wing rises, and the latter drops. This motion is called 'roll.' Your aircraft banks in the direction of the roll—the direction you moved the stick.

Flaps Built into the backs of the wings are flaps, which you can extend or retract as necessary. These are used most often during landing, but they do have the occasional other purpose. Extending the flaps ("flaps down") has several results. First, lift is increased, so the plane rises; next, drag is also increased, so the plane slows. Overall (and this is most important), the flaps lower the speed at which the aircraft will stall. This means that, when landing, you can approach more slowly without stalling or, conversely, dive to a landing more steeply (because the flaps slow you), then "flare"—bring the nose up sharply just before touching down—and the flaps will kill most of your speed. Keep in mind that when you retract the flaps ("flaps up"), the plane will drop a bit. Some pilots use partial flaps for extra lift during take-off. If you are one of these, do not raise your flaps too soon after take-off, or you may find yourself at a negative altitude. Note that in addition to flaps, the German Me 109 also has *s/ats* built into the front of each wing. These provide much the same function as flaps.

Rudder The rudder is a horizontally tilting section of the vertical part of the tail. Through drag, it affects the yaw of the plane. When the rudder is moved left or right, the nose yaws to that direction. Not using the rudder in turns can cause a rough ride, and ruddering can be extremely crucial for lining up shots, aligning a straight approach for landing, and recovering from a spin.

You can use the **wings**, indirectly, as a control surface to manipulate lift. When you change the plane's angle of attack (using the elevators), the airflow over the wing changes. A greater angle of attack creates more lift—to a point. If this angle gets too big, and the plane's airspeed is not high enough to maintain a smooth flow (you try to gain too much lift too fast without enough thrust), turbulence will take away all of the lift. Without lift, the plane will stall and drop like a rock—you go into a dive and sometimes a spin. At low altitude, this can be fatal if there is not enough time to regain the thrust needed to re-establish the air flow. A lesser angle of attack creates less lift.

Inertia

All good pilots are aware of the effects of inertia on their aircraft and on their bodies. One definition of inertia is "the tendency of any object to resist a change to its state of motion." What that means is that if your body or your plane is sitting still, it wants to stay that way; if it is moving in a particular direction at a particular velocity, it wants to retain that speed and heading.

While in flight, inertia makes maneuvers more difficult at higher speeds. The faster your plane is moving, the more inertia it has in the direction of movement. Thus, the engine and control surfaces have to do more work to get the plane to change direction.

The most noticeable problem inertia causes is g forces. The 'g' is a standard abbreviation for acceleration due to gravity; in this case it is used to denote any acceleration experienced by the plane and pilot. Whenever you change direction, you are subject to g's. If you turn to the side (as in yawing or banking), you're putting a centripetal acceleration on the plane and your body. Inertia (often mistakenly called "centrifugal force") tries to keep you moving in your original direction, causing "transverse g's." When you turn downward, "negative g's" make you feel lighter, as in a dropping elevator. If you turn upwards, as when pulling out of a dive, "positive g's" push you down into your seat. Positive and negative g's entail risks—blackouts and redouts.



LEVEL FLIGHT

Level flight is accomplished when all the forces are in balance. In this state, the aircraft moves at a constant speed without changing its altitude. Most of the aircraft in *European Air War* are stable by design. That means that if you leave the controls alone, a correctly trimmed airplane will (eventually) go into level flight at a particular speed and altitude. This is also called “trimmed flight.” If the plane is going faster than the trimmed speed, then it tends to pitch up and slow down. If it is going slower than the trim, the plane tends to pitch down and speed up. A gentle hand on the stick and perhaps a little rudder is all it takes to maintain level flight. If you find it difficult to level your plane, the control surfaces (rudder, ailerons, and such) may have been damaged. Return to the base as soon as possible for repairs.

Pilots generally make level flight easier by setting the “trim” of the aircraft. Trimming is analogous to calibrating a joystick to center. You can “calibrate” the elevators to compensate for lift and the ailerons and rudder to compensate for roll. In *European Air War*, all of this is done for you by the automatic trim feature. Though this may seem unrealistic, the theory behind it is simply that trimming comes effortlessly to a pilot as skilled as you, like breathing. You don’t think about it; you just do it.

ACCELERATION AND DECELERATION

Acceleration and deceleration—speeding up and slowing down—are primarily governed by the effects of thrust, drag, and gravity on the aircraft. To increase your speed, you can increase the thrust (add throttle), decrease drag (pull in your landing gear), or trade altitude for speed (dive). To slow down, decrease thrust (less throttle), increase drag (take a turn), or fight gravity (climb). In general, more throttle means higher speed, and less means lower speed. Drag is affected by many factors, including the angle of attack, altitude, and airspeed of the aircraft, as well as the flaps and landing gear settings.

LEVEL CLIMB AND LEVEL DESCENT (RISING AND FALLING)

Level climb and level descent—gaining and losing altitude without changing the pitch of the aircraft—are accomplished by changing the amount of lift generated by the wings. To start a level climb, increase throttle. This increases the speed of the aircraft, and thus the amount of lift generated, and the aircraft climbs gradually. To lose altitude without gaining speed, cut back on the throttle. The reduced speed generates less lift, and the aircraft descends gradually.

Green pilots tend to fly at full throttle all of the time. That’s a bad idea, because doing so consumes more fuel, and your engines can overheat. A veteran pilot knows the cruising speed of the plane and maintains that speed until a combat situation arises. This conserves fuel for the important part of the flight—keeping yourself alive during the minutes of aggressive flying during a dogfight.

CLIMBS AND DIVES

Climbs and dives are more dramatic ways of gaining and losing altitude. To climb, pull back on the stick. The farther you pull, the steeper the climb will be. Keep in mind that the steepness of any climb is limited by your airspeed and the capabilities of the aircraft. The best angle of climb (and most efficient) for most aircraft is about 20 degrees above the horizon, at full throttle. To dive, push forward on the stick. The farther you push, the steeper the dive. Be forewarned that a steep dive will cause you to gain airspeed rapidly.

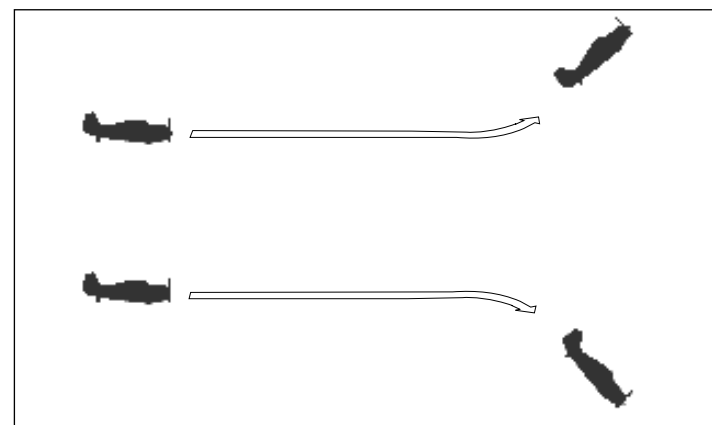

Climb and dive

The reason this works is that tilting the plane changes the angle of attack of the wing surface. The angle at which air encounters the airfoil determines the amount of lift acting on the plane. A greater angle of attack means more lift, so your plane rises. A lesser angle of attack means less lift, causing your plane to fall.

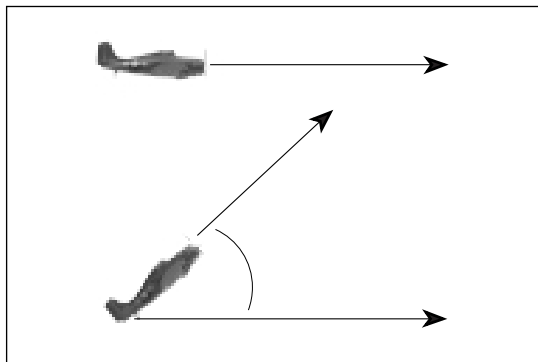

Angle of attack

Remember also that quick, steep dives are the main cause of redouts. Combat pilots who want to lose altitude quickly will not normally push the stick forward. Instead, they flip the plane over, then pull back on the stick to “climb” downward. Repeating the flip and climb straightens the plane out again, or you can continue the downward “climb” and end up pointing back the way you came (if you have room; otherwise, you end up as a lawn dart). Please refer to the **Split-S** maneuver in the **Advanced Flight** subsection for a detailed description and a diagram.

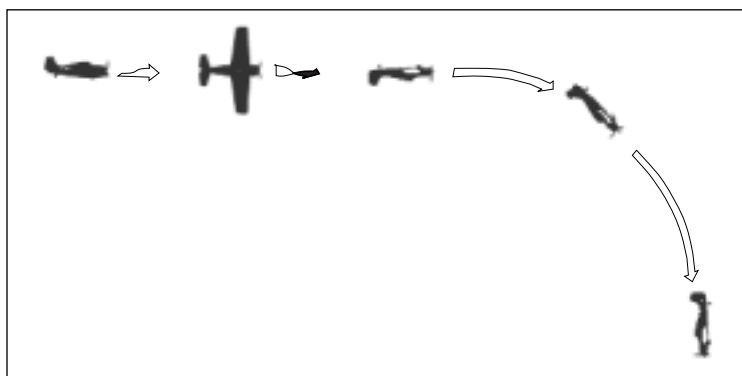

Steep dive

SIMPLE TURNS (BANKING)

To perform a simple turn, push the stick to either side. The plane rolls in that direction, which redirects the wings’ lift (remember, wing lift acts in whatever direction the top of the wing is facing, not necessarily straight up). The plane “banks” to that side, and you turn in that direction. Pulling back on the stick tightens the turn. You will notice that you lose speed as you turn, the nose starts to drift downward, and you begin to lose altitude. Add throttle to speed up, then pull back on the stick and ease the rudder in the opposite direction to counter this drop. For every aircraft there is an optimum airspeed for making nice, tight turns. If you are flying faster than this optimum, your turn will be more open than necessary; if you are below the optimum airspeed, you will lose altitude more quickly.

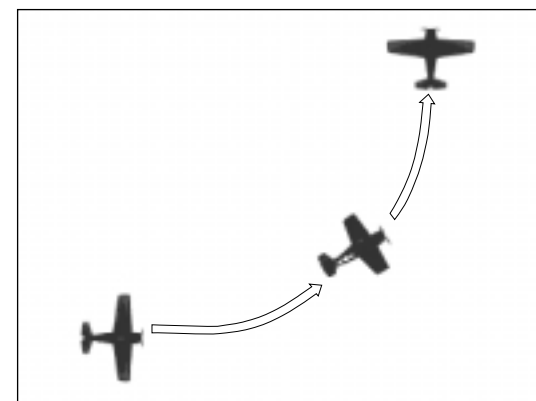

Simple bank

FINAL ADVICE

You can learn more advanced maneuvers from watching your fellow pilots, especially your leader. Analyzing the tactics of the enemy is another good way to learn. (According to Sun Tzu, your enemy is the most important teacher of all.) During dogfights, though, you’re usually pretty busy, and there’s rarely time for analyzing every move. Just keep your eyes open and do the best you can.

INSTRUMENTS

The instruments in the cockpit do not vary substantially from plane to plane. (German instruments are marked according to the metric system, while the American and British ones are calibrated to imperial units.) Every aircraft in the European theatre is outfitted with the same essential instruments, though they are certainly not in the same place in every cockpit. *European Air War* reproduces the most important instruments, leaving out some of the complexity of the cockpit instrumentation to facilitate game play. The basic set of gauges and dials is summarized here.

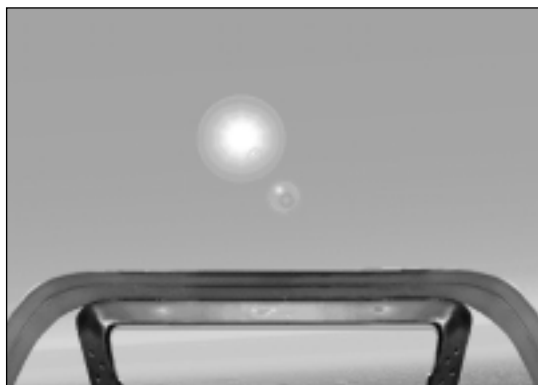

Sample cockpit: Heads-up view



Sample cockpit: Lap view

Remember that many (if not all) of the instruments in your cockpit will be located below the "dashboard" visible in the standard cockpit view. Tilt your view down and up or use the **Virtual Cockpit** mode view to get a look at these gauges.

COMPASS



Magnetic compass

The compass is a simple, magnetic direction indicator. Whatever heading is at the top of the indicator is the direction in which the nose of your aircraft is pointing. Headings are numbered from 000 (zero) to 360, starting and ending at due North and proceeding clockwise. Thus, due North is both heading 000 and 360, East is 090, South is 180, and West is 270.

ARTIFICIAL HORIZON



Attitude indicator

The artificial horizon (also called the 'Attitude Indicator') is a floating ball that indicates your plane's relation to the surface of the Earth, or attitude. This is extremely useful when visibility is poor or when for some other reason you cannot see the natural horizon. If you are flying level, the artificial horizon will be centered and flat. If you are banking or rolling, it will be at an angle. When you climb, the light part (the "sky") will cover more of the gauge; when you dive, the dark part (the "ground") covers more. Keep in mind that the artificial horizon represents the actual, natural horizon. This is not radar! Irregularities in the surface of the Earth (mountains and such) are not reflected on this gauge.

AIRSPEED INDICATOR



Airspeed

The airspeed indicator is a dial that registers the speed of your aircraft in relation to the air around it. This airspeed is indicated in miles or kilometers per hour. Keep in mind that your airspeed must remain above a certain minimum (different for each model of aircraft) to stay aloft. Lower airspeed means greater control of the plane's lateral (horizontal) movement, but less power for climbing.

TACHOMETER



RPM

The tachometer dial measures the rpm (rotations per minute) of the aircraft's engine. Under most circumstances, this is also the rpm of the propeller crankshaft. (Many planes had step-up gears and such, so this is not always true.) This indicator of engine power is relative to, but not directly determined by, the amount the throttle is open. Though the tachometer can serve as a rough guide to how much throttle you have on, especially during level flight, do not rely on rpm for an exact gauge. Knowing your engine's rpm is primarily useful when you are planning a maneuver that requires a certain amount of engine power—climbing, for example, or pulling out of a particularly steep dive.

ALTIMETER



Altitude

The altimeter tells you how far above sea level you are. The short needle indicates thousands of feet, the long needle indicates hundreds. So, for example, when the long is at 2 and the short is at 4, you are 4,200 feet above sea level. Since none of the aircraft in *European Air War* is equipped with radar, radar altimeters are out of the question. Your altitude is measured as a function of the ambient air pressure, *not absolute altitude*. What this means to the pilot is that you can trust your altimeter only when flying over ocean (which is pretty flat and by definition very close to sea level). Over land, you must stay alert for changes in the topography. If you are less than 100 feet above a 2,000-foot mountain, your altimeter will still read 2,100 feet. An inattentive pilot might feel safe making a dive and later (assuming he survives) wonder why he crashed.

OIL PRESSURE GAUGE



Oil pressure

The oil pressure gauge, like the one in an automobile, keeps track of the pumping pressure of the oil that lubricates your aircraft's engine. Since your flight crew are the best your nation has to offer, you can assume that there is nothing wrong with the engine when you take off. If you start to lose oil pressure, there can be only one explanation—your engine has been damaged by enemy fire.

The leak may not be a bad one, but you shouldn't take chances. Try to return to your take-off point right away. Otherwise, the oil will eventually all run out, and the plane's engine will seize (stop working suddenly). You might, with luck, be able to glide to a safe landing, but it's much more likely that you'll end up a sitting duck for enemy pilots to shoot down. If you choose to stay in the fight and then wind up bailing out, fine. Living to fight another day is better than going down with your plane. However, unless you had a damn good reason for staying, expect a reprimand. Bringing your country's plane home with you is more important than seeking personal victories.

ENGINE TEMPERATURE GAUGE



Engine temp

The engine temperature gauge indicates the operating temperature of your aircraft's engine. As you warm up prior to taking off, this gauge should rise from the bottom to hover approximately in the center of its range. Under normal conditions, engine temperature will not deviate substantially from this center. Note that combat flying at high rpm is *not* considered normal conditions.

Performing combat maneuvers, running the engine without oil, carrying heavy loads, or remaining aloft when the engine has been damaged all may cause the temperature to rise to dangerous levels. If it nears the top of the indicator's range, there is a good chance your engine will cease functioning. *Avoid this if at all possible!* Although you will hear stories of overheated engines that were restarted in flight after cooling off, these are almost miraculous exceptions to the rule. Overheating causes permanent damage to the engine which must be repaired to make the aircraft airworthy.

FUEL GAUGE



Fuel gauge

The fuel gauge, like the one in a car, tells you how much fuel is left in the tanks. The level in your main tank is measured by the bright white "Main" needle of the gauge, while the level of fuel in any external tanks is indicated on the dimmer "Reserve" needle. When the reserve tank runs out, the engine begins drawing from the main tank automatically. Once the external tank is empty, you should consider jettisoning it. Without the excess weight of the empty tank, your plane will handle better and fly faster.

MANIFOLD PRESSURE GAUGE



Manifold pressure gauge

The gauge labeled “MP” measures manifold pressure. This is an approximate measure of the air pressure inside the engine. Taken together with the tachometer reading, this information gives you an idea of how much horsepower you have available. A lower manifold pressure means less available power, while a higher one (always assuming that the pressure is not great enough to destroy the engine) generally means you have more power.

Note that the MP can also be a reliable indicator of engine damage. If your engine is punctured by one or more bullets or chunks of shrapnel (or anything else), the manifold pressure will start to drop. A drop in pressure all the way to zero means one of two things: either you have turned the engine off, or it has ceased functioning.

Manifold pressure has a habit of becoming slightly lower as your altitude increases, reflecting the decrease in ambient air pressure. Thus, at higher altitudes (usually above a certain optimum operating altitude, which is different for each model of aircraft) you will tend to get a little less power for the same amount of throttle.

RATE OF CLIMB INDICATOR



ROC

The ROC indicator lets you know how quickly your altitude is changing. Though you can get a rough approximation of this by watching the altimeter move, sometimes you need to know in a glance, and that’s where the ROC comes in. If the needle is above the centerline, you’re climbing; if it’s below, you’re diving (or falling). Different planes have different scales (x 10, x 100, x 1000, etc.), but the hash marks on the dial will always indicate a number of feet per minute (or meters, in the case of German craft).

AMMUNITION COUNTER



Ammunition counter

In contrast to the other basic cockpit instruments in *European Air War*, the ammunition counter is not standard equipment; it can be found only in German planes—and not even in all of these. The counter, as you might have deduced, shows a pilot exactly how many rounds are in his guns at any given moment. Pilots of Allied planes (and those unfortunate German airmen in older model aircraft) must resort to estimating their remaining rounds.

FORMATIONS

If you’ve gone ahead against advice and flown a mission or two without reading this, you probably noticed that the aircraft in your flight are flying in formation. This is standard procedure, even if your flight is only yourself and one other pilot. Your flight should stay in formation until the enemy engages you in combat or the mission ends. All of the normal formations you will encounter in *European Air War* are variations on basic themes.

ECHELON

Echelon formations come in two flavors: *echelon left* and *echelon right*. The planes fly behind and to one side of each other, forming a diagonal or “stair-step” line. This type of formation can accommodate any number of aircraft, although it is not suggested for more than five. A two-plane echelon is the standard lead and wingman formation.

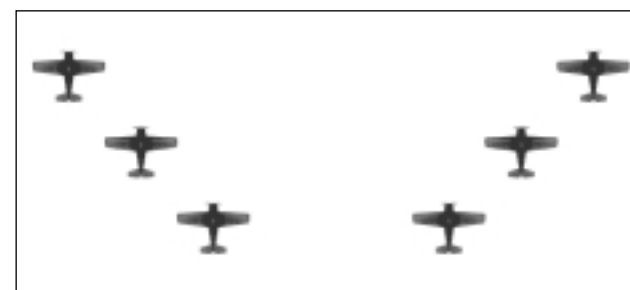

Echelons

V

V formations, or “vees,” are the standard formation for flights of bombers (and geese). The lead aircraft is flanked by two planes flying slightly behind and to each side, thus forming the V. Any further planes extend the legs of the formation; the standard V does *not* include any aircraft within the legs of the V. When there is an even number of aircraft in a V formation, the flight leader decides which leg will be extended. The two-plane V is essentially the same formation as the two-plane echelon.

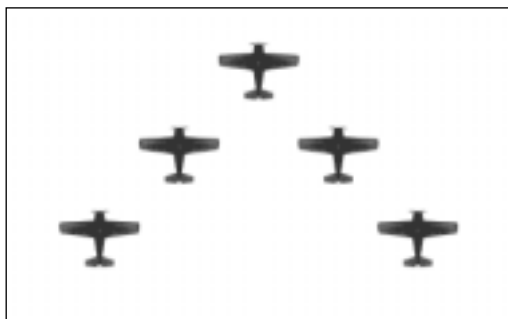

V formation

FINGER FOUR

The Finger Four formation, also known as the ‘Rotte and Schwarm’ or the ‘Double Attack’ system, is a variation on the standard V. It was first designed and implemented by the Germans, but both British and American forces quickly adopted it as well. It is perhaps the most common flight pattern found in *European Air War*.

Developed by ace Werner Mölders, it is an inherently flexible formation consisting of two groups of two fighter planes whose flight pattern, viewed from above, resembles the fingers of an outstretched hand (minus the thumb). Each pair (‘rotte’ or ‘element’) consists of a leader and his wingman. The leader is the senior flyer of the two and the better marksman. A wingman flies slightly lower and behind the leader, with the sole responsibility of guarding his leader’s tail. In the Finger Four, the two pairs (together called a ‘schwarm’ or ‘flight’) generally work in concert and take direction from the senior leader. When forced to split up, however, each leader-wingman unit can act independently of the other.

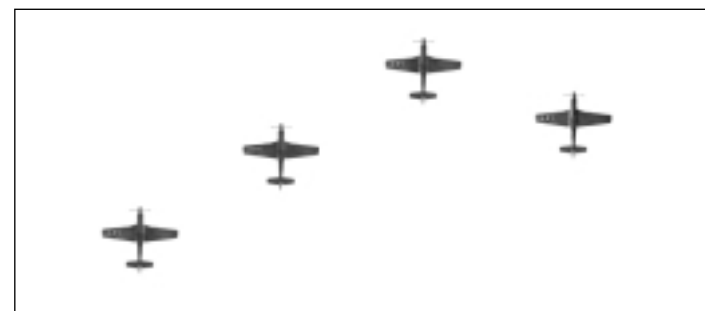

Finger Four formation

BOMBERS AND ESCORTS

Bombers and their escorts fly near each other, but not in the same formation. As noted above, flights of bombers generally travel in a V formation. The escorting flight of fighters should keep 1,000 feet above the bomber group and 1,000 feet out in the direction from which the enemy is expected. Any formation is acceptable for the fighters, as long as it maximizes the protection of the bombers.

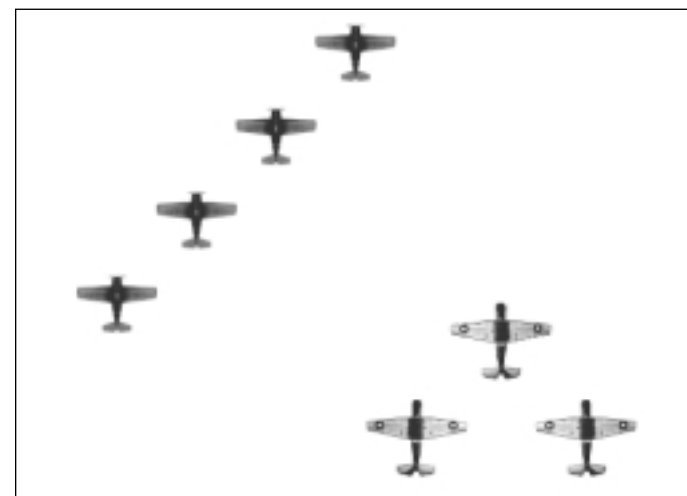

Bomber escort

SIMPLE MANEUVERS

There are several easy maneuvers that are not only basic, but essential to combat flying. You may already be familiar with some of them. Regardless, you ought to practice each time you begin flying a new type of aircraft; every plane reacts differently, and you should always adapt to your aircraft—it will not adapt to you. Know your plane's inherent advantages (like the Spitfire's high rate of turn) and use it against your opponent. Also remember that maneuvers should only be performed when you have enough altitude.

AILERON ROLL

This is not a stand-alone maneuver, but rolling with your ailerons is a basic component of almost every other possible maneuver, trick, or trap you might use. Pull back slightly on the stick first, so that the aircraft is in a gentle climb. Next, push the stick all the way to either side, hold it there, and the ailerons cause the plane to roll. Center the stick again once you return to an upright attitude. Now roll in the opposite direction. Notice how your plane acts during the rolls: which direction it "likes" to go in, how much speed and altitude you lose, et cetera. Little things like this get to be vital during a close-in dogfight.

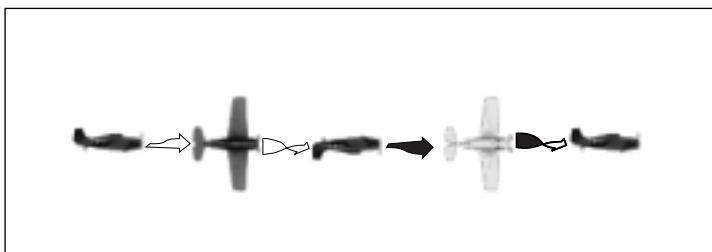

Aileron roll

Now roll into the inverted position and center the stick there. Spend a little time upside down and see what the plane tries to do. Roll back over whenever you're ready (preferably before you hit the ground). The half roll is the first step in many an important and useful maneuver.

BARREL ROLL

A barrel roll is similar to the aileron roll, but has a lateral component that turns it from a spin-in-place to more of a corkscrew motion. Performing the full roll is of value primarily as an evasive maneuver when the enemy is on your tail. The barrel roll is similar to the aileron roll, however, in that a partial roll is often used as a part of another, more complex, maneuver.

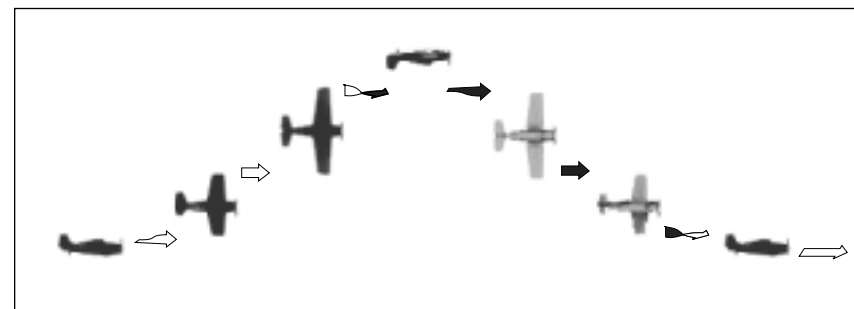

Barrel roll

To perform this roll, you push the stick to one side as in the aileron roll, but you also pull it back a bit, initially swinging the plane out and slightly up. A perfect barrel roll brings you back to the same position and altitude, but lowers your airspeed. (Normally you will lose some altitude.) It is the lessening in your speed that will sometimes trick your opponent into overshooting. When you recover your position, it's likely you'll be sitting right in his "six" (flying at six o'clock, or directly behind him).

LOOP OVER

The loop over is what most people simply call a 'loop.' A related maneuver, the *loop under*, is also covered here; thus the slight difference in the name. The loop is, essentially, a way to turn your plane over and end up back where you started.

Make sure you have plenty of airspeed and altitude before you try a loop over. If you run out of steam partway through, you will stall and could end up in a spin, which is bad. Pull the stick all the way back and hold it there. If you start to stall, give the plane more throttle. During the first half of a loop over, you will lose airspeed dramatically. This makes you an easy target for anyone who foresaw the maneuver. If you do notice someone shooting at you, however, you can easily roll out of the loop and enter a dive, using up some altitude to gain speed. Unfortunately, an enemy who saw the loop coming will probably be ready for the dive, too.

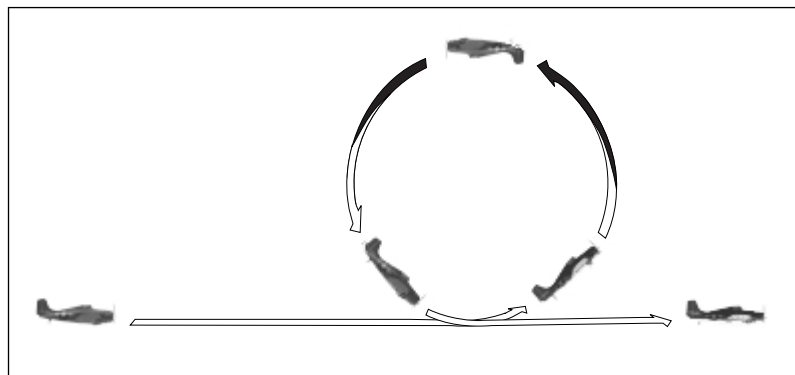

Loop over

After you reach the top of the loop, you won't need the extra throttle any longer; you'll reclaim almost all of your lost airspeed from gravity during the second half. At the end of the loop, if you've done it right, you should return to the same heading and speed you started with. Center (neutralize) the stick for level flight.

LOOP UNDER

The loop under is essentially a reversed loop over, except that it can be more dangerous. It is also more valuable in combat, since you gain speed quickly early in the loop. The loop under is used as one step in some more complicated maneuvers.

You don't need to worry about airspeed when you start, but you do have to consider your altitude. If you don't have enough altitude to pull out in time (at least 5,000 feet), don't try it. Perform half an aileron roll, so that you're inverted. Pull back on the stick and hold it there. During the first half of a loop under, you will gain airspeed quickly. This can be pretty handy when trying to elude an opponent. Do not do anything to slow yourself down, or you may not be able to complete the loop.

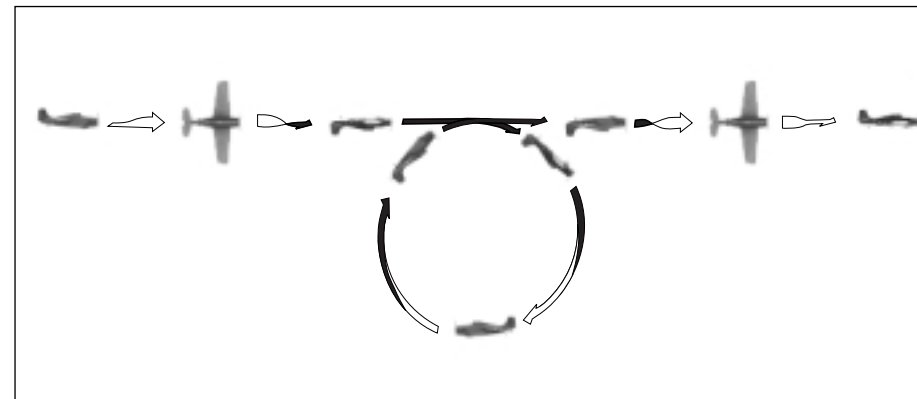

Loop under

After you reach the bottom of the loop, you'll stop accelerating and begin to lose airspeed on the way back up. This is when you become vulnerable to any enemy who sees what you're doing. If it becomes necessary, you can increase throttle to finish faster or simply roll out of the loop. At the end of an uninterrupted loop done correctly, you should return to the same heading and speed you started with. Flip right-side up, then neutralize the stick to return to level flight.

WING OVER

The 'wing over' is what was originally called an 'Immelmann.' However, there is another Immelmann maneuver now, so this turn has been renamed. A wing over is a handy way of turning around at the end of a strafing run, but it's not much use in a dogfight. Since you begin the turn by climbing, thus losing speed, you'd be a sitting duck for any alert opponent. Note that you cannot perform this maneuver unless you use the rudder.

As mentioned, you start a wing over by pulling back on the stick and climbing. The idea here is to gain a little altitude *and* lose some airspeed. Therefore, do not increase throttle to compensate for the plane's slowing down. One of the consequences of the aerodynamics of flight is that rudders are most effective at low speeds.

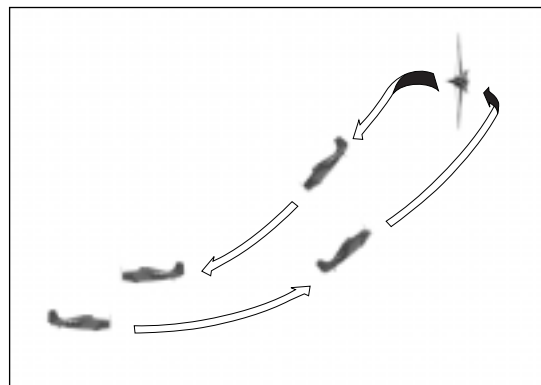

Wing over (old Immelmann)

When you have sufficient altitude to begin another run *and* your airspeed is in the good range for rudder control, it's time to turn. Kick the rudder full to either side and neutralize the stick. Your aircraft should do a quick 180-degree turn, exactly like a car doing a J-turn. Push the stick forward and go into your strafing run.

EMERGENCY PROCEDURES

What distinguishes an extraordinary pilot from an average one is often the same thing that separates the heroes from the corpses—how you deal with emergencies. What really tests a pilot's mettle (outside of combat) is the terrifying, all-but-hopeless case when only nerves of steel and reflexes as fast and as sure as instinct can save your neck. It would be nice to think you'll never need to know any of the emergency procedures outlined in this section, but let's be realistic.

RECOVERING FROM A STALL

A stall isn't really an emergency—unless you don't know how to deal with it. A wrong move during a stall can easily put you into a spin, and if you can't cope with a stall, you sure as hell won't be able to save yourself from a spin.

Your aircraft will stall when it does not have enough lift to balance out the force of gravity. There are lots of ways this can happen, but two are most common. The first is a simple lack of thrust. Since thrust is what keeps the air flowing around the wing, and since airflow generates lift, lack of thrust equals lack of lift.

To recover control from this type of stall, you don't really have to do anything. The nose of the plane will dip when you stall, and you will start to gain speed as you dive. The extra speed should cancel the stall, and you'll regain control of the aircraft. Alternatively, you could increase throttle. This is probably the better option, since otherwise you'll just stall again.

The second kind of stall is slightly more complex. Whenever your aircraft is climbing, the angle of attack is increased. If you do not have enough forward motion (thrust) to compensate for the loss of lift this causes, the plane could stall. This is a more dangerous type of stall than the other, partly because of its complexity and partly because you were probably climbing for a reason.

Regaining control of your plane can be troublesome. Since you were climbing, your nose is pointed up. The first tendency of the aircraft, then, is to go nose-down and act like a rock. Let it. Neutralize the stick and you can control the direction in which the nose falls using the rudder. If you're not at too great an angle, you may even be able to get the nose to fall forward into a standard dive.

Once you're diving, neutralize the rudder and use the stick to straighten out. Pull out of the dive as gently as your altitude and situation allow. Next time, be sure you have enough airspeed for the climb, or use more throttle to avoid stalling.

One further piece of advice: If you go into the second type of stall too low, you'd better bail out. Remember, you've got to have enough sky under you to safely recover *and* get out of the resulting dive. Otherwise you haven't got a chance.

THE POWER STALL

There is a third type of stall that you should understand—the power stall. Getting out of a power stall is no different from escaping any other type of stall—put your nose down first thing and you'll be successful every time (assuming you're far enough from the ground). *There is no better or faster way to regain control of the aircraft in a stall.* What's different and difficult about the power stall is knowing when you're at risk and recognizing the stall when it happens.

The reason a power stall is so vicious is that it usually comes as a complete surprise. Most pilots realize that, when they're flying at low speeds, yanking the stick all the way back is likely to cause a stall. What is less intuitive is that the plane can in fact stall at *any* speed. The only things that matter are the forces acting on the aircraft and how they affect the angle of attack (AoA) at which the plane is flying. The fact is, a stall is *always* caused by flying at too large an angle of attack—that's the definition of stalling. Knowing how maneuvering affects your AoA is key to avoiding power stalls.

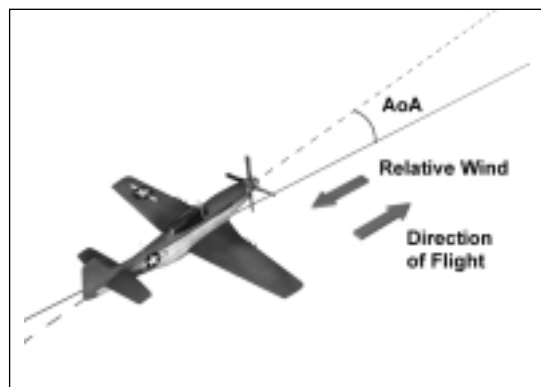

Angle of attack

In normal, straight (unbanked) flight, your AoA is directly related to the amount you pull back or push forward on the stick. This gives you a reliable measure of when the plane is likely to stall—*until* you start to encounter significant acceleration forces. As you're well aware, the direction in which the nose of the plane is pointing is rarely the direction in which the aircraft is moving. The nose aims in the direction you dictate with the elevators, but although the plane tends to *try* to go in that direction, it generally moves in a slightly different direction—the net result of the forces of gravity, drag, thrust, lift, and torque on the plane. For our purposes, it will suffice to say that the difference between the two directions is roughly equivalent to the AoA. (The exact angle of attack is the difference between the direction of the relative wind and the "no-lift line" for each airfoil.) Note that each wing has its own AoA, as does every airfoil that is part of the craft. In straight flight, both wings have the same AoA, thus they will stall at the same time.

When will an airfoil stall? It will stall when its AoA is high enough that the airflow over the top separates from the surface and becomes turbulent. The loss of lift caused by this turbulence is called a stall. The particular AoA that will cause this is different for each wing, and often different for parts of the same wing. In fact, many modern wings are designed to stall from the body outward, so that the pilot has some warning of an impending stall, but still has control over the unstalled ailerons on the outer ends of the wings.

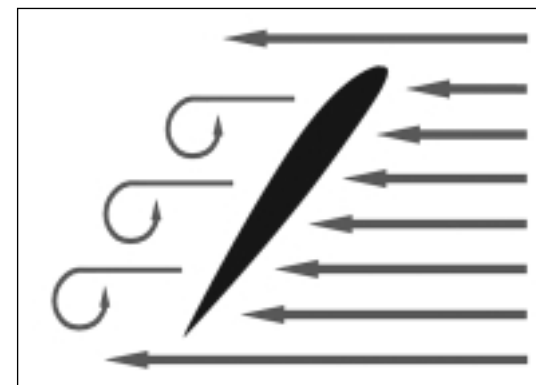

Stalling airflow

Acceleration, also known as the g force, does not change the angle of attack. What acceleration does is change the weight of the plane and its contents, a process called 'g loading.' If you enter a full-power climb from level flight, the g's push you down into your seat. That's because the change in direction—the *acceleration* away from your original course—actually makes you temporarily weigh more. This acceleration has the same effect on the entire aircraft. Since a heavier plane with the same wing area has less lift, it will stall at a lesser AoA. The acceleration has caused you to be suddenly and drastically closer to stalling your plane.

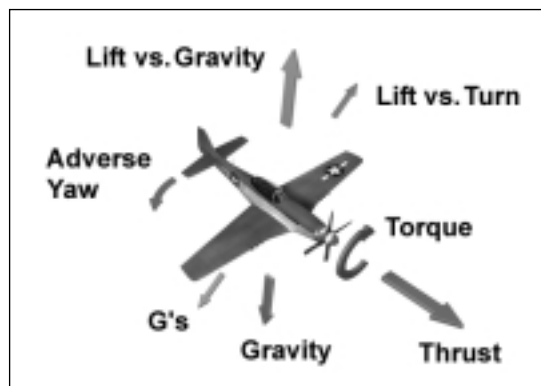

Physical forces acting on a banking plane

When the wings are banked, things start to get complicated. First off, the turn that results from the bank is a change of direction. Thus, the plane is accelerating (and hence temporarily weighs more), and the AoA needed for a stall is smaller. Next, the total lift generated by the wings is no longer directly upward. Part of the generated lift must counteract the g force of the turn, leaving less to negate the normal force of gravity. This does not directly affect the chance of a stall, but it causes the pilot to take some action to keep the aircraft from losing altitude. Usually, what the pilot does is rudder a bit and pull back on the stick, thus increasing the AoA. Now the aircraft is much closer to stalling than in level flight, and the pilot had better keep that in mind.

If the plane does stall in a banked turn, it is because the pilot tried to get the aircraft to do something that it could not. Trying to turn more tightly than airspeed and loading will allow is a common mistake of this type. The things that make this more dangerous than a basic, wings-level stall are (1) you may not know that you are stalled, and (2) each of the wings can stall independently and differently. When the nose starts to drop toward the ground in a turn, the pilot's natural assumption is that more rudder is necessary. If the pilot is already using a lot of rudder or foolishly applies heavy rudder suddenly during the turn, chances are good that one of the wings will yaw ahead of the other, causing the aircraft to skid somewhat. When this is the case, the backward wing—the one the pilot ruddered toward—is at a higher AoA than the forward-skidding wing. That backward wing will stall first, significantly ahead of the other, and the aircraft will enter a dangerous spin so quickly that the pilot could be caught completely off guard.

The best way to survive a power stall, then, is to avoid it. Be aware of your effective AoA at all times. But if you do find yourself suddenly stalled, don't hesitate to drop the nose and lessen your angle of attack—no matter what your altitude. Even 50 feet off the ground, losing 30 feet while regaining control is preferable to losing 51 feet and ending a promising career.

GETTING OUT OF A SPIN

Spins are potentially the most dangerous situation a pilot can get into. The pilot's handbook for almost every aircraft warns against entering a spin intentionally, since they can be so difficult to escape. Unlike some other "unconventional landings," a spin will almost *never* conclude with a survivable touchdown. You must either get out of the spin or get out of the plane.

If you go into a spin at any altitude below 3,000 feet, bail out immediately—you do not have enough maneuvering room to save your plane, so you may as well save your life.



If you feel you have enough room below you, your first action should be to jam the rudder hard (“with a positive motion,” the books say) in the direction opposite the spin. That is, rudder left for a clockwise spin and right for counterclockwise. Hold it there. At the same time, haul the stick as far as it will go in the same direction as the spin. (Stick left for a counterclockwise spin and right for clockwise.) Do not adjust the throttle at all. Soon, you should “pop out” of the spin and regain control.

If you don’t, try again—and keep trying. Often, if you were going exceptionally fast when you entered the spin, you should allow more time for the recovery. Unless you feel you are gaining control, you should bail out when you get too low.

If and when the spin eases and you feel control of the plane returning to you, you will find yourself in a dive. Ease out of it as gently as your altitude and situation allow, so as to avoid going into another spin.

LOW FUEL

It happens. Maybe you get caught up in a long, drawn-out dogfight. Maybe you have to go around one too many times to get your bombing run just right. Could be you just weren’t paying attention, or you unintentionally jettisoned your external tank. Whatever the situation, sooner or later you’re going to have to fly home on fumes. In this situation, you have two problems: getting home and getting down.

Don’t think, “Oh, no problem. I can just quit the mission and I’ll be okay.” It’s not true. Assuming you’ve completed your mission objective and you do choose to skip the flight home, *European Air War* decides whether you make it back based on your *current* speed, altitude, attitude, and leftover fuel. The autopilot won’t try to minimize your fuel use, either. The only way to get home on low fuel is to do it yourself.

Your biggest problem when your fuel is low (unless you’re very near your home base) is how to get the most mileage out of what little fuel you do have. There are three strategies to consider, and the chances are good that your best bet is a combination of these three.

First, trim your aircraft for low-drag flight. Part of this trimming is getting rid of any extra weight. Make sure you’ve jettisoned that empty external fuel tank, then drop any ordnance that may still be attached to your plane. (Verify that there aren’t any friendlies below!) The other part of this tactic is a clean profile. Double check that your flaps are fully retracted and your gear is up. Remember that damage to your fuselage will add to the drag on your aircraft—but, unfortunately, there’s nothing you can do about that.

MINIMUM DRAG PROFILE CHECKLIST

- ☐ External fuel tank detached
- ☐ External munitions detached
- ☐ Flaps fully retracted
- ☐ Landing gear raised

Next, there are some minor advantages to flying at a higher altitude. Flying higher means flying faster and farther without using more fuel. Here’s how it works. The higher you are, the thinner the ambient air gets and the lower the pressure. Lower ambient air pressure means two very important things: less lift and less drag. The aircraft in flight is designed to be a balanced, self-regulating physical system. Therefore, as you rise and both lift and drag decrease, the forces acting on the plane continually shift to stay in balance. Less lift means the plane “wants” to nose down a bit and go faster. Less drag means it *can* go faster. Higher speed brings the nose back up, and these forces eventually come into balance. Here’s the key, though—they come into balance at a higher true airspeed *with no change in the throttle setting*.

One thing to note is that this increase is in *true* airspeed, not *indicated* airspeed. The airspeed indicator will show the same—or lower!—even though you’re actually moving significantly faster in relation to the ground and the air around you. This is because the indicated airspeed is a pressure-based measurement, and is thus affected by the loss of pressure in the same way as the lift of the wings.

Finally, the most important piece of strategy is the aircraft's *L/D Max*, a measure developed primarily for use with modern jet fighters, but perfectly applicable to any powered aircraft. *L/D Max* is shorthand for "that airspeed which provides the maximum coefficient of lift over drag." In other words, the airspeed at which your plane will fly most efficiently. For all of the aircraft you can pilot in *European Air War*, the *L/D Max* is roughly in line with the plane's cruising speed.

What good is that? It's actually fairly simple. First, figure out how far you are from your home base. (Consult your cockpit map; it's not cheating.) Now multiply that number by 200. The result is *approximately* the altitude you need to start from to reach the runway if you fly at the *L/D Max* the whole way. Pull your nose up to a 20 degree angle and climb at full throttle to that altitude. Set the throttle to idle (10%), then assume whatever attitude is necessary to stay at the *L/D Max*. This will get you as close to the runway as is possible with your remaining fuel.

Note that if the altitude you need to reach is above 20,000 feet, you should probably still climb only to 20,000 feet to start your power glide; if the runway is more than 100 miles away, you can re-boost yourself later, as it becomes necessary and as fuel allows. Once you've fixed your speed and attitude for greatest mileage, stick with it. The flight home is going to be long and boring, and there's no movie, but it's better than the alternative.

When you get there, follow the instructions for an unpowered landing. More than likely, that's what it'll turn out to be.

DAMAGE

Even exceptional pilots get shot up now and again, so chances are you will, too—in which case, you'd better be able read the signals and react quickly. The cockpit instruments will be your first warning that your plane has taken a hit. Sluggish controls or loss of command are also good clues. Unfortunately, there is absolutely nothing you can do to repair your aircraft while in flight (except when on a multi-player mission). Your only recourse is knowing how to cope.

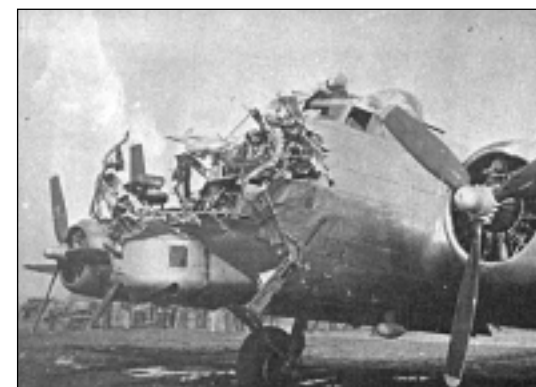

This B-17 made it home because the pilot knew what he was doing.

Remember, once you're airborne, you are in command. If the damage to your aircraft is severe enough that you have trouble controlling your flight, you have a command decision to make: whether to continue on and attempt to complete your mission. Use your best judgment. Severe damage will make your mission impossible, and you might need to return prematurely. If the damage is too great, you may even have to bail out in order to save your neck.

COMING IN ON A WING AND A PRAYER

You're out of gas, the engine's been shot up, there's a hole in the wing you could drop a bowling ball through, and the rest of your flight is either home already or never getting there. You're on your own and you've somehow got to coax the plane in. Don't get your hopes up.

Gliding

If you have no power, obviously you'll have to glide. Luckily, the plane you're flying glides much better, unpowered, than the average bomber would. Gliding, in terms of speed and attitude, is similar to flying at the *L/D Max*, but with important modifications.

When there is no power, the engine becomes nothing more than a source of drag. The propeller windmills (spins in the wind), causing even more drag. All this extra drag slows the plane and steepens the glide slope. To regain your L/D Max and, therefore, fly as far as you can from your present altitude, you will need to drop the nose somewhat. How much depends on the characteristics of the plane you're piloting. Slowly stick forward until your IAS gets close to L/D Max. As long as you're at the right airspeed, you know that the plane's glide slope is as distance-efficient as it can be.

Unpowered Landing

The end of the long journey home is actually less difficult than you might think. Landing without power is just like landing with power, except that your descent slope is going to be steeper and you're going to be in a hurry. The only other problem is control; that is, you won't have very much. Even with power, controlling the aircraft is difficult at the extremely slow speeds necessary for landing. Without, it's just that much worse.

Gliding the landing requires more foresight and better reactions than usual. It's like everything happens in slow motion. The controls are sluggish, the response reluctant. You can get better control by nosing down and picking up some speed, but keep in mind that this will change your descent slope. On the bright side, chances are your rudder will be more responsive, since it works best at lower speeds. Beyond a certain point, however, there is simply not enough air moving past the rudder to give you any control effect.

The best advice for unpowered landing is to get it right the first time. You don't get a second chance. Once you've traded in all your altitude and speed, you have nothing left. If you miss the landing, you'll just have to hope for the best.

FIRE

If your aircraft is burning, what you do depends on where you are. Generally, the first warning sign of a fire will be the enormous, black billows of smoke coming out of the rear of your aircraft. This means that the aircraft's fire control system has not been sufficient to extinguish the fire. You have only a few viable options, and none of them is particularly pleasant.



This one's a goner.

You should attempt to return to a friendly airfield only if you feel you have a good chance of making it. (That is, if you can see the airfield from where you are.) Be careful when landing a burning aircraft on a friendly runway; you can cause all sorts of collateral damage during a flaming landing. Note that safely landing a burning plane is extraordinarily difficult. Most pilots will not attempt such a maneuver unless they're suicidal.

If you aren't close to an airfield, but you believe you can safely crash-land or ditch, feel free to try. Then, too, you could always bail out. There's no real difference between that and a crash landing—except that you're much more likely to survive if you hit the silk. Whatever you decide, don't dilly-dally; you probably don't have much time to act before the fire reaches the fuel tanks.

If you have no other options—you can't bail out and your chances of surviving a crash are nil—you can always use your wounded craft as an offensive projectile. *You will not survive, and this is not a recommended tactic.*

BAILING OUT

Bailing out—abandoning your aircraft and parachuting to the surface—is a simple, last-ditch attempt to save your life when your plane has been shot up. All you have to do is get your plane as close to level flight as you can manage, then jump from the cockpit.

Vital Note: It is not possible to bail out safely if your altitude is too low. If you can't get above 3,000 feet, attempting to land is your only safe option.



What happens once you're on the ground depends more on luck and where you landed than on your survival skills. Enemy territory is patrolled regularly, and very few pilots have made it back.

One last bit of advice. Headquarters wants to assure you that parachuting pilots are *not* considered viable targets. None of the reports of the enemy's firing on defenseless pilots and their 'chutes has been confirmed. You know how these rumors spread.

THE AIRCRAFT, CONSIDERED AS A PROJECTILE WEAPON

All that careful, drag-your-half-dead-body-back-to-the-base stuff is fine for some people, but going out in a blaze of glory and carnage also has a certain allure. Why go to all that trouble saving your neck, when you could slam a couple of tons of flaming steel into a strategic target?

Most pilots like to wait until they've used up all their other destructive options, though it's not a requirement. Any bombs still attached to your plane when you hit probably won't go off (they aren't armed), but any fuel left in your tanks makes a nice fireball. Fact is, if you're considering a "kamikaze" maneuver, you've probably already gotten your plane toasted and are desperate for a way to wreak some extra havoc. When your plane is damaged, you have less than perfect control over it. Take these directions as guidelines, then; they're pointers to what you should do, if you can.

Approach your target (the nearest one or the one you think will look the most satisfying in flames) as if you're on a dive bombing run. Come in as high as you can. The farther you fall, the more time you'll have to aim yourself. Keep in mind that any enemy planes are still out there trying to shoot you down, and the flak isn't going to go away, either.

When you're almost directly over your intended victim, go into a 95-degree dive with your flaps fully extended. Here's why. At a 90-degree dive, your plane is still moving forward, which will take you past the target. At 95 degrees, the aircraft falls straight down like a rock, with the added convenience of being able to see your target the whole way down. The flaps are to keep your speed down, so that (hopefully) your plane won't break up before impact; parts just don't hit with the same satisfying crunch as the entire plane.

Nobody's aim is perfect, so you may need to make adjustments on the way in. Remember that in a dive of this angle and speed, your rudder is of little value. The ailerons, on the other hand, can come in handy. Use them in coordination with forward and back control on the stick—much as in a Split-S—to keep yourself on target. The ailerons can also impart a twisting spin to your plane, which is quite a stylish way to smack into the ground.

ADVANCED FLIGHT

If you understand everything in the previous sections, then you're well on your way to becoming a useful pilot. At this point, you could probably survive for a few whole seconds against an experienced opponent.

Now, you're going to learn a few things which will help you turn that survival time into a chance to perforate the enemy's plane. Note that the potential uses of the techniques described here are only suggestions; any maneuver is as versatile as the pilot who undertakes to learn it.

A LITTLE AIR COMBAT THEORY

The idea of flying a fighter in combat can be intimidating. No matter how good you are at cruising around, once you get into a dogfight situation, all of a sudden you're on your way to the ground. Your career is over, and you don't even know what happened. As a beginning fighter pilot, you might feel outclassed, but don't be hard on yourself. The fact is, the guy flying the enemy plane simply knew a little more about air-to-air combat than you—this time.

There are several ways to overcome this minor hurdle. Many pilots just practice and study flight films until they figure things out for themselves. Good for them. The rest of us get a book out of the library and read up on tactics, then come back to the cockpit and kick some butt. Some of us are lucky enough to have experienced pilots around to ask for advice. Whenever these experts start in, they always go for specific maneuvers. There's an underlying set of basic knowledge, though, that they take for granted. Without getting into too much detail, here are three of the more vital pieces of information.

Energy Management

What fighter pilots call 'energy management' is extremely important when flying jets. It's doubly essential when you're buzzing around in a prop plane; you have a tiny bit more leeway in timing, but you don't have a huge afterburner to fall back on. Any of you who don't already know what energy management is, throw away your first ideas. It not only has nothing to do with saving fuel, but it also doesn't involve the aircraft's electrical system. What a good, experienced pilot always keeps in mind is what your Physics 101 teacher called the Law of Conservation of Energy.

There are two types of energy the pilot has to worry about in this context: kinetic and potential. When you're talking about the whole aircraft, kinetic energy means velocity—airspeed. When you're flying slowly, you don't have much kinetic energy; when you're really screaming along, you've got heaps of it. Potential energy is just what it sounds like; it's anything that you can easily turn into kinetic energy. Altitude is what pilots use as a rough gauge of how much potential energy they've got; the higher you are, the more you have. Fuel is also a form of potential energy, but it takes time to turn fuel into speed. When you're thinking about energy management, think of fuel as a distant second to altitude. Since energy is easily transformed from one type to another, you can also turn speed into altitude (by climbing) and fuel into altitude. (You cannot, however, turn altitude or airspeed back into fuel.) The cornerstone of energy management is that you have only so much energy stored in your aircraft—kinetic plus potential plus fuel—you can't ever get any more, and you want to have as much of it available for quick maneuvering as you can.

If you have sufficient airspeed, you can easily and *quickly* escape from an unexpected attack or perform whatever maneuver you have in mind. If you don't have enough airspeed, but do have altitude, you can *quickly* turn your height into speed by diving, then escape or maneuver. If you have neither, however, you can't do anything except pour on the throttle and *wait*. Waiting is bad when someone is shooting at you. Any experienced pilot will tell you that "low and slow" is as good as dead in a dogfight. Energy management is knowing what your current energy state is—how high you are and how fast you are moving—and knowing what your options are should you need to do something with that energy. It also helps if you can estimate your opponent's energy state, keep track of it, and take advantage of the knowledge.



"Low and slow" equals trouble.

So how does this translate into useful advice? First of all, you never want to enter a fight if the other plane has a significantly better energy state than you. Next, you should try to avoid maneuvers that will leave you going slowly at a low altitude. If you notice your opponent using his energy unwisely, get ready to shoot him down. Once the other plane gets into a "low and slow" situation, you have a perfect opportunity to blast it apart—but only if you've been a smart energy manager yourself.

Even when you're finishing off an opponent, keep your own energy state in mind and don't get careless. The enemy you just shot down probably isn't the only one nearby, and one of his friends is usually right on your tail. That's where situational awareness comes in.

Situational Awareness

"Situational awareness is an essential component of tactical success in airborne combat"—that's just the seven-dollar way of saying that to live through a dogfight, you need to know what's going on around you. Seems like common sense, but many inexperienced pilots forget. It's an artificial distinction, but situational awareness can be split into six categories. All rolled together, these pretty much cover everything that you need to be aware of at every moment of every mission.

The Environment: Is there any cloud ceiling? If so, how high? How thick? Where is the sun? These things can be extremely useful to you and your opponents during a fight, so know the situation before you go into it. It's relatively easy to get this info into your head and keep it there; it doesn't normally change as the combat progresses. Other environmental considerations that will be important (even if you don't use every advantage, sooner or later you'll run into an opponent who will) are the locations of nearby land features—hills, mountains, valleys, etc. Every one of these is a potential hiding place, a shield, and a weapon for use against an inattentive enemy.



Dangerous hiding places

Your Aircraft: Without a doubt, this is the most vital aspect of situational awareness. Everything you can know about the state of your plane and its aerodynamic situation will become important during the fight. You must protect your weak points from your opportunistic enemies, and you should use your strong points to advantage. Know your energy state (altitude and airspeed), what your maneuvering options are, and how many seconds of ammunition you have left. Watch your fuel gauge and keep your engine temperature in mind. Remember your aircraft's strengths and weaknesses. Don't forget what's attached to your wings and belly, in case you need to lose weight. Last, but not least, stay aware of your position with respect to the target and your home base. After some experience, all of this will become second nature.

Your Bandit: The state of the enemy plane that you're currently engaging is almost as important as that of your own aircraft. After all, you're trying to kill each other. With some practice, you will be able to read his energy state and know what his maneuvering options are. After maneuvering skill, this is probably the single most useful expertise you will ever develop for dogfighting. Watch everything he does; every move tells you something about his energy and his intentions. Most pilots can't help but telegraph their next move, and that can give you an advantage. Remember, he's watching you the same way. Some of his moves could be feints or deceptions, and he could be trying to lure you into a bad energy state or some other trap. Know what his aircraft is capable of and try to decipher his plans.

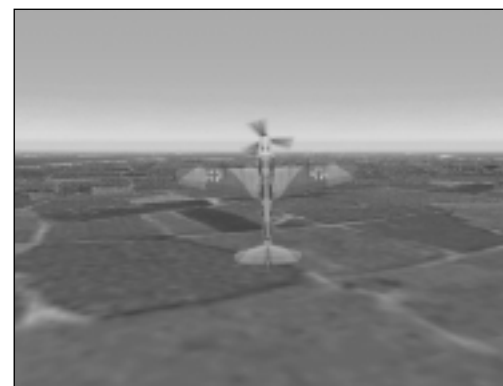

What's he up to?

Other Bandits: Except for unusual circumstances, you'll rarely be fighting in a vacuum. The bandit you're chasing (or being chased by) might be setting you up, and you'll never know it—until it's too late—if you're not aware of where his buddies are. At the very least, you should try to determine as early as you can how many of them there are, what altitudes and speeds they're flying at, and what formation they started in. You don't need to watch the energy states of every one of your enemies, but if you're that good, it doesn't hurt to know. Just keep in mind that any one of them could be your next target or the threat on your six (directly behind you). Try to know, at least in a rough way, where every one of your enemies is. The enemy pilots will cooperate with each other, and you could easily be the worse for it if you're not watchful.

Allies: Good pilots try to watch out for one another. The rest of the planes on your side, especially any bombers you're supposed to be escorting, deserve your help whenever you can give it. You should know where your friendlies are, just like you know where the enemy planes are—at least approximately. Helping out aside, avoiding collisions becomes a consideration in a tight dogfight; not every pilot is good enough to both watch where you are and avoid the fighter on his tail. If you get a free moment, without engagement, you might even spot one of your allies getting a bandit into an "opportunity situation." This is what happens when two planes have maneuvered to a stalemate (as in a matched one-circle fight) and neither can escape or gain an advantage. At this point, a third plane can enter the dogfight and easily shoot down one of the two combatants. If you're attentive, you could help a buddy and get an easy kill on your record.



Surface Forces: Though less important than anything in the air, the AAA emplacements down on the dirt certainly have an effect on your situation. Know where they are. Even if the fight starts out a safe distance from anti-aircraft emplacements, you're going to be maneuvering all over the place up there and might very easily fly into their range unintentionally. Once the range closes, you could be in heavy flak without ever realizing you were getting into it. An occasional glance down at the deck (easy when you're banking) will keep you up to date.

If you can keep all of these factors in mind and still remember your name, then you just might make a good combat pilot.

Lethality

Fighter pilots in the WWII European Theater have to think about lethality on every mission. Lethality is a combination of factors—including firing rate, muzzle velocity, effective range, deflection angle, caliber, relative velocity, drag, gravity, time of flight, and g deflection angle—that determine the damage potential of any gun burst. These factors are relevant to any shot taken with machine guns, cannon, or even rockets. In most cases, you'll have an almost instinctive feel for the lethality of a particular shot, but it doesn't hurt to have the details. Fairly often, your instinctive feel is dead wrong.

Ace pilots fire only when they can "touch" their enemy. That means firing every gun on the plane for that brief few seconds when the enemy is close enough that the sight of his plane fills your cockpit glass. Being able to do this means having the skill and patience to maneuver into position (while your enemy is trying to prevent you from doing so), fire a short burst, then painstakingly maneuver into position again. One mitigating factor is that if you damage his plane on your first attack, getting lined up for a second attack becomes that much easier.

The whole idea behind lethality is to maximize the amount of damage you do with the amount of ammunition you have. If you shoot only when you know you will hit, you need not fret over the other factors of lethality.

Note that lethality is an important consideration when the opponent is at a distance of *more* than a couple of hundred feet; when he's closer than that, you've got plenty of lethality to spare, and you should be worrying more about avoiding a collision.



The effects of the weapon's *Rate of Fire* are pretty straightforward. The higher the rate of fire (ROF), the faster the weapon fires and the more projectiles are launched at the target per second or burst. Assuming that your aim is on the mark, a higher firing rate means more damage per second of fire. Thus, a higher ROF means a greater lethality. Of course, it also means fewer seconds of fire in the long run, which doesn't affect the lethality of any one burst, but it certainly limits the number of bursts you'll get.

Muzzle Velocity is the speed at which each projectile leaves the gun. This velocity is all the energy the slug has to overcome friction with the air—*Drag*. Thus, muzzle velocity and, to some extent, altitude and air density (which can change the drag coefficient of the air) determine the *Effective Range* of each bullet. In simple terms, the farther away your target is, the slower your bullets are going to be moving when they hit it. The slower they're moving, the less damage they're going to do. For rockets, these considerations are less important at close ranges. Once the propellant runs out, though, a rocket acts just like a bullet; then, drag begins to take its toll.

Time of Flight is a similar consideration, but a more elementary one. How long does each bullet take to get to the target? Most of the factors that limit lethality are time-dependent; the lethality goes down as the time goes up. Drag is essentially a factor of air density and distance to the target, but you can easily estimate the effects of drag as a function of time of flight. (The slug slows down so much each second.) The effect of *Gravity* on your projectiles depends purely on how long each one is in flight. Every second that a bullet is on its way, it accelerates downward another 32 feet per second. (Thus, after five seconds of flight, a slug will be moving forward more slowly, due to drag, and downward at 160 ft/sec because of gravity.) This will tend to throw off your aim and lower the lethality of the burst. The effects of deflection are also time-dependent.

Deflection is a term you'll hear bandied about frequently among people who know a lot about air-to-air combat. What they're talking about is the angle from which you're approaching your target when you fire (deflection angle). If you're directly behind another plane, you've got the best angle there is—no deflection at all. Firing at a plane from the front is the same, except that you have a lot less time. Any other angle is a tougher shot and will do less damage. In fact, the farther you get away from the straight-on shots, the worse your chances get—your lethality goes way down. To hit from a 90 degree angle, you have to lead the enemy aircraft so much (offset your shot) that the target might not even be visible! Note that the deflection angle works essentially the same way horizontally and vertically. If you're on a different level than your enemy, diving in on him or climbing up under him, you're deflected, and your shots won't be quite as damaging. On the other hand, the enemy may not know you're coming, which is certainly an advantage.



45-degree deflection

There is a related deflection effect that can ruin a shot when you're turning; it's called *G Deflection*. Whenever you pull g's, your bullets do, too. Despite their muzzle velocity, the slugs are subject to all the laws of physics. As soon as a projectile leaves the gun, it begins to travel in a straight line in whatever direction the gun was pointing when it fired. Since you're pointing in that particular direction for only a moment, the shots will seem to lag behind your motion. To overcome this, you must offset your shots to compensate for your turn.

The *Relative Velocity* of your target is another effect that causes a need for offset. This one is more "natural" than the others—easier for most folks to estimate. If you were sitting in a tower with a machine gun, you would know that you had to take into account every moving target's velocity relative to your position. The same consideration is true in a moving gun platform; it's just easier to forget. If your opponent is coming into your field of fire from above, for example, you need to fire a little below his plane—by the time the bullets get there, the aircraft will have moved to meet them. The hard part is accurately estimating your target's velocity relative to you. Planes fly around at all kinds of bizarre angles, and it may take a little practice before you get good at it.

Caliber is easy to explain. The bigger the projectile, the more damage it will do. Thus, cannon rounds hit harder than machine gun rounds. (Cannon rounds are also explosive, which adds to their damage capability.) Larger projectiles also tend to incur more drag, so the effective range will be lower unless the velocity is higher.

What all of this physics and dynamics boils down to is that some shots are going to do more damage than others. The closer you are to your target, the better. The bigger the slugs you're throwing and the faster they move, the bigger the hurt you'll put on the other plane. The faster your guns can pump out lead, the more hits you'll get. If you're directly behind your target, you'll get a great shot. If you're approaching each other head-on, just make sure your aim is good. Coming in from any other angle, it's more difficult to get a hit. Never forget to lead your shot ahead of a moving target and above where you actually want it to go. If you can hit a running receiver with a ball, you should be able to shoot down fighters.

YOUR WEAPONS

Before we get into the discussion of your approach and combat, it's a good idea to have some familiarity with the weapons at your disposal. Naturally, you're limited to what's available for the aircraft you expect to pilot, but there's almost always some room for choice.



Some description of every weapon follows. While most of the information is self-explanatory, one thing warrants a little explanation. Whenever you drop, launch, or fire a projectile, you're hoping it will impact and damage an enemy structure (plane, bridge, whatever). If it hits or near misses, your weapon *might* do damage to the target. Here's the part that needs explanation: there's no way to know exactly how much damage any particular hit does. A hit could ricochet, and a bomb might be a dud. A near miss could spray shrapnel into a store of munitions. There are always those factors, bizarre or ordinary, that cause more or less damage than you'd expect. In real life, you take your chances. In *European Air War*, the same rule applies.

Machine Guns and Cannons

Bullets and cannon rounds are best used against those pesky enemy fighters and bombers. Nonetheless, those of you with a predilection for close-in destructive action will find yourselves down on the deck again and again, strafing. There's a certain wild excitement to swooping in on some unsuspecting target and toasting it with your guns.

In *European Air War*, there are some important qualifications to the sheer joy of strafing. One is that you cannot damage any strategically valuable installation with mere bullets. This is unfortunate, but realistically accurate. Your average military installation is hardened, or armored, to minimize the damage from bombs and artillery shells. Thus, bullets just bounce off. A strafed area might begin smoking or even seem to be burning, but no actual damage has been done. You've just ignited something that was left lying around. Lesser targets, however, are a different story. These you can not only damage, but also destroy with machine gun and cannon rounds.

.303-caliber Browning Mk2 MG

Weight	22 pounds
Length	44.5 inches
Muzzle Velocity	2,660 feet/second
Rate of Fire	1,200 rd/min

The Browning Mk2 .303-caliber machine gun is the low end in firepower; you'll find it only on fighters of the RAF. Its lack of punch is compensated for by the fact that these guns are usually installed in foursomes.

7.92 mm Solothurn MG17

Weight	28 pounds
Length	47.7 inches
Muzzle Velocity	3,000 feet/second
Rate of Fire	1,100 rd/min

This Solothurn machine gun is standard armament on many Luftwaffe planes. Adapted from another German stalwart (the MG15), the fixed-mount MG17 is similar in firepower to the British Mk2.

.50-caliber Browning M2 MG

Weight	64 pounds
Length	57 inches
Muzzle Velocity	2,850 feet/second
Rate of Fire	750 rd/min

In the USAAF, the .50-caliber machine gun is the bread-and-butter weapon. In fact, some fighters don't have anything else. The ROF is lower than that of the British .303-caliber, but the "point fifty" more than makes up for it in punch; its large bullets have a devastating impact, and the gun is accurate even from a distance. As an added advantage, you'll usually have a wing full of them.

13 mm MG131

Weight	40 pounds
Length	46 inches
Muzzle Velocity	750 m/second
Rate of Fire	930 rd/min

The MG131 is the German equivalent to the Browning .50-caliber machine gun. It's a little lighter and shorter, and the ROF is higher, but the differences are outweighed by the similarities. Don't underestimate this gun; it's everything that the American point fifty is.



20 mm M2 Hispano Cannon

Weight	102 pounds
Length	94 inches
Muzzle Velocity	2,850 feet/second
Rate of Fire	600 rd/min

The 20 mm Hispano cannon, used by both the American and British forces, is slow and dangerous. The ROF is quite low, which gives you plenty of firing time, and each explosive shell does several times the damage of the .50-caliber machine gun bullet. This gun's got the moxie for some serious strafing.

20 mm Mauser MG151/20 Cannon

Weight	93.5 pounds
Length	69.75 inches
Muzzle Velocity	2,650 feet/second
Rate of Fire	800 rd/min

With a higher rate of fire than most comparable weapons, this cannon packs a wallop. It has the same basic design as its smaller cousin, the 151/15, but it fires explosive shells and can therefore inflict more damage—lots more. This gun is a favorite on a number of German planes.

30 mm Mk108 Cannon

Weight	198.9 kg
Length	2,335 mm
Muzzle Velocity	500 m/second
Rate of Fire	380 rd/min

The German Mk108 discharges 11 oz. explosive shells that can take a serious toll on any target. The rate of fire is low, but the damage each hit does more than compensates. In the hands of a skilled pilot, this gun is quite effective.

Rockets

It was during this war that the first self-propelled air-to-ground projectiles were put to regular combat use. Note that most of these miniature rockets—available only on certain planes—are not really designed for air-to-air use. (The German 21-centimeter rocket is the exception.) Rockets are, essentially, bombs you can aim.

5-inch Rocket

Weight	90 pounds
Length	55 inches
Maximum Velocity	875 feet/second

Both British and American forces use a 5-inch rocket. For its part, the RAF invented an entirely new weapon, while the USAAF actually recycled an existing one; American rockets are nothing more than modified AA shells stuck onto a 3.5-inch, fin-stabilized rocket motor. The two rockets are nonetheless quite similar, and each does roughly half as much damage as the M43 500 lb bomb. (In 1944, the Americans' early rocket was replaced by the "Holy Moses" 5-inch HVAR—with a full 5-inch rocket motor—though the new projectile didn't see regular use until '45.)

M8 4.5-inch Rocket

Weight	38.4 pounds
Length	34 inches
Maximum Velocity	860 feet/second

Late in 1943, the American forces developed a tube-launched 4.5-inch rocket. It does serious damage to anything it hits, but it's quite difficult to aim; because of a delay before the rockets reach their maximum velocity, gunners are hard-pressed to estimate the projectile's path with any accuracy. The four-and-a-halves are installed in racks of three per wing and are available only on the P-47D Thunderbolt.

21 cm Rocket

Weight	248 pounds
Length	42.44 inches
Maximum Velocity	650 feet/second

The German-designed 210 mm rocket, with its 80 lb. warhead, sits slung beneath the wings of Luftwaffe aircraft. (Single-engine planes carry two of the 50 inch launching tubes, while twin-engine craft can manage up to four.) The rocket's primary use is against bombers, in particular to break up large formations and expose individual planes to attack.

Bombs

American ordnance comes in a few different sizes and types, and not all of them will be available for the fighter you're flying. The two you can regularly use are both of the GP/HE (General Purpose/High Explosive) type—50 to 60 percent explosive, and the rest steel. Though not designated armor-piercing (AP) or even semi-armor-piercing (SAP), these types of bomb do have the potential to sometimes damage armored targets.



The USAAF thunders toward its target.

The M44 1000 lb. GP bomb isn't the largest HE device dropped by American aircraft, but it's the biggest you can carry with a fighter. (It's really only 965 lbs.) This bomb can be used against industrial targets, as an antipersonnel ordnance, and to put big holes in runways. It is not particularly effective against massive, concrete submarine pens. The fuse was modified several times during the war, in an attempt to produce as much damage as possible with one hit.

The smaller egg for the USAAF is the M43, a 510 lb. HE bomb. As you might expect, it does about half as much damage as its bigger brother, although—unlike some of the lighter USAAF bombs that are best against airfields and transport lines—the M33 can still mete out punishment on industrial targets.



M43 500 lb. bombs hang beneath the wings of this American aircraft.

Like the Americans, the **British** rely on 1000 lb. and 500 lb. bombs to do most of their dirty work. The RAF also makes extensive use, however, of a 250 lb. explosive device. Because of its light weight, this bomb is of little use against the majority of ground installations. It can't pierce either thick, concrete walls or armor plating. On the other hand, it's quite effective at potholing runways, roads, and bridges. Not only is this annoying to the Germans, but it also means they must spend valuable time and resources to patch things up, thus sapping supplies desperately needed elsewhere.

The **German** air force calls on two heavy hitters—a 500 kg (1100 lb.) and a 250 kg (550 lb.) bomb—to do most of its knuckle breaking. Slightly heavier than the comparable American or British versions, these explosives put quite a hurt on ground targets. Both are reasonably effective against industrial targets, and either one is easily carried by a fighter.

APPROACH

Now that you've been introduced to the basic concepts of air combat and to the weapons you might have on your plane, let's talk about dogfighting. As soon as you identify an aircraft as belonging to the enemy, the conflict has begun. Even though neither of you can effectively fire on the other yet, one of the keys to aerial combat is the balance of advantage and disadvantage in approach positions.



The first and most important consideration is *Awareness*. You are already aware of the existence, the position, and the approximate speed of the other plane. Depending on the angle at which you are approaching, he may not know you are there. (The converse is also true; if you suddenly see tracers cross your line of flight from behind, someone has gained a serious awareness advantage over you.) You can usually tell by the other pilot's action—or inaction—whether or not he has spotted you.

The next thing to consider is *Altitude*. Whichever aircraft is flying at a greater altitude has a distinct tactical and energy advantage. However, approaching most bombers from above is a mistake, as their tail guns are designed to protect from exactly that type of threat.

Speed is another vital consideration. The faster plane, like the higher one, has an energy advantage. More speed means more climbing ability and outrunning potential. Remember, though, that the slower plane is better able to maneuver (to a point) when it comes to rudder effects and tight turns. The faster aircraft may also be lured into overshooting, thus becoming a rather easy target.

The *Deflection* at which the attacking aircraft approaches is also critical. A pilot gets his best shot (most likely to do damage) when he fires along the flight path of the other plane. Otherwise, the uncertainty factor of leading the enemy comes into the picture. Deflection is measured by the angle the attacker's path makes with the path of the target. The greater the deflection, the less likely the shot will hit.

All told, the more advantages you have (or can create for yourself) *before* you start the fight, the more likely you are to be the victor. Putting those advantages to good use, however, is a matter of pilot skill and experience.

DOGFIGHT VS. HIT-AND-RUN

The differences between the two basic types of aerial fighting are analogous to the contrasts between boxing and wrestling. A pilot with an advantaged approach often has the power to decide what kind of fight it's going to be, but a fast, maneuverable aircraft with an experienced pilot can force the fight to go the other way.

When most people say 'dogfight,' they mean any midair conflict between aircraft. For simplicity, that's a good definition, but a pilot has to know better. A dogfight develops when two or more planes close with one another, getting into a close-quarters duel of maneuverability (usually a one-circle or two-circle fight). Obviously, if your aircraft is significantly less maneuverable than your opponent's, you will want to avoid this kind of close-contact fighting.

The other option here is an open conflict, which is sometimes called a 'hit-and-run' fight. In this type of aerial combat, the aircraft involved make repeated strafing passes ("slashing" attacks) at each other, depending on firepower, strategy, and endurance to win the day. This sort of battle emphasizes the advantages of altitude, speed, and situational awareness (knowing what's going on around you). Of course, if you know your plane isn't as tough or as hard-hitting as your enemy's, you should avoid hit-and-run fights.

IMMELMANN

The modern Immelmann is a time-honored method of gaining altitude and (potentially) changing direction. It is a combat maneuver, but not one that you want to use when an enemy is on your six. At the beginning of the Immelmann, you lose speed and become vulnerable to attack. For this reason, you should use this particular tactic only when there's no *immediate* threat. The modern Immelmann is best used after a nose-to-nose pass, to turn for the next pass and gain altitude for an advantaged position.

It is important that you have enough airspeed; the Immelmann is a lot like a loop over. To start, pull back on the stick as if you are performing a loop. When you are exactly vertical (pointed straight up), you are at the decision point of the maneuver. This is where split-second thinking and reactions come in handy. If you're on the ball, you can roll your aircraft without losing your sense of position. Whatever direction the top of your head is pointing in when you leave the decision point is the direction your plane will take when you finish the maneuver.

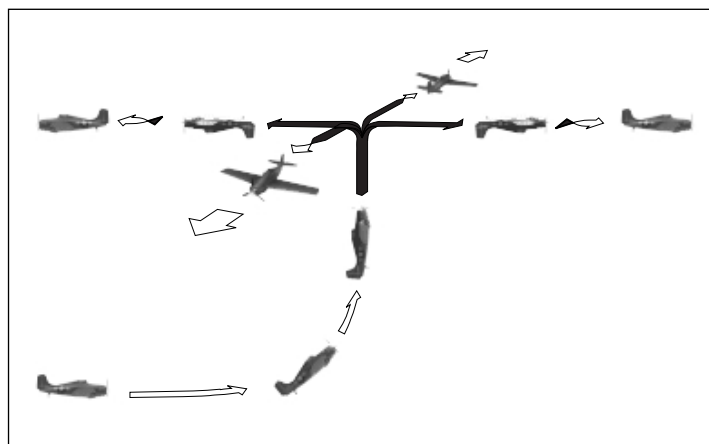

Modern Immelmann

After the roll, which should take place almost instantly, continue the loop until you reach the top. At this point, neutralize (center) the stick. Note that you are, in fact, moving in the direction that you chose at the decision point, though you are inverted. Roll the aircraft over. You have gained altitude and changed direction, though now your speed is significantly lower. If your opponent remained at the original level, you now have an altitude advantage *and* he doesn't yet know what direction you're going in.

SPLIT-S

The Split-S is really an inverted (vertically reversed) Immelmann, but nobody calls it that. It's a great way to drop a lot of altitude, gain speed, and change direction. This maneuver is often useful for escaping an opponent who is just about to shoot you down. Not only is it nearly impossible for your opponent to guess what direction you're turning in—making it difficult for him to follow you—but your new airspeed should give you more than enough juice to run away and end the dogfight.

In this case, airspeed is not important; you'll be getting plenty right from the start. To begin, invert the aircraft and pull back on the stick as if you are performing a loop under. When you are exactly vertical (pointed straight down), you are at the decision point of the maneuver. This is where split-second thinking and reactions come in handy. If you're on the ball, you can roll your aircraft without losing your sense of position. As with the Immelmann, whatever direction the top of your head is pointing in when you leave the decision point is the direction your plane will take when you finish the maneuver.

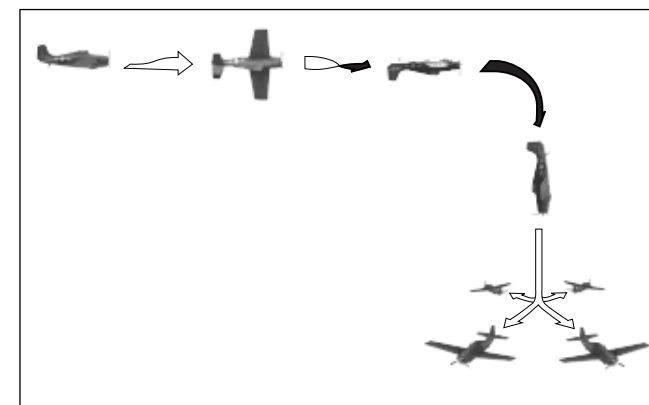

Split-S

After the roll, which you'd better finish quickly, continue the loop until you reach the bottom. At this point, neutralize (center) the stick. Note that you are, in fact, moving in the direction that you chose at the decision point. You have lost altitude, changed direction, and significantly raised your airspeed. If your opponent remained at the original level, he now has an altitude advantage, but he doesn't yet know what direction you're going in.

INTENTIONAL STALL

Despite what you may have read, heard, or seen, there is absolutely no reason to stall the aircraft intentionally unless you are performing in an air show. In combat, this will get you killed—period.

SKID

Skidding is a rudder maneuver you can use offensively, but it takes some practice. Sometimes, you're behind an opponent (at about the same altitude), but not at the right angle to take a shot at him. He knows it, and he's flying straight, counting on it. You're both moving at below top speed. If you bank toward him, you'll get a short shot, but then you'll be past and he'll be on your tail. What you need to do is swing the nose of the plane around *without* changing the direction of your motion. Can do!

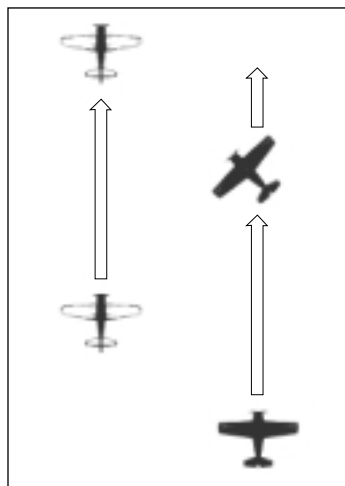

Skidding the shot in

Jam the rudder in the direction of your enemy (that is, rudder left if he's on your left, rudder right if he's to your right). If your speed is right (in the range for good rudder control), the nose will drag itself over until you have a clear shot. Take it.

SLIP

Slipping is another simple rudder maneuver, though you also need to use the ailerons in this one. Its primary use is for momentarily dodging out of the line of fire of an opponent who has gotten the drop on you. You could probably use it, too, in place of a skid, to slide in behind the enemy plane.

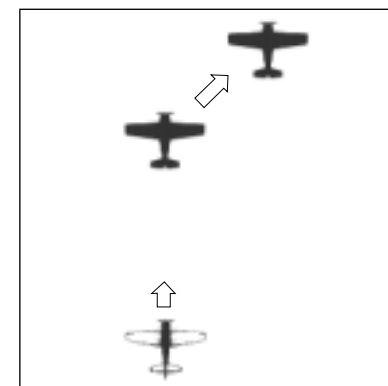

Slipping out

Rudder hard in either direction, while at the same time banking in the opposite direction. This is a lot like compensating for a normal bank, but you want to use more rudder. The key here is that the two forces cancel each other as concerns roll; the plane should remain level. Level or not, your aircraft will "slide" to the side you banked toward. This is as close as you'll get to flying sideways. Once your enemy catches on, he'll slip, too, to catch you. You can repeatedly slip back and forth, thereby eluding him for quite some time. (Maybe help will come, or maybe he'll make a mistake and you can escape.)

SCISSORS

The Scissors is a basic dogfighting technique. Two planes traveling in roughly the same direction cannot easily line up for head-to-head passes. Rather, they engage in a criss-crossing pattern of banked turns, each trying to outturn the other and shoot first. Since lower airspeeds lead to tighter turns, the scissors is sometimes called the "race to go slow."

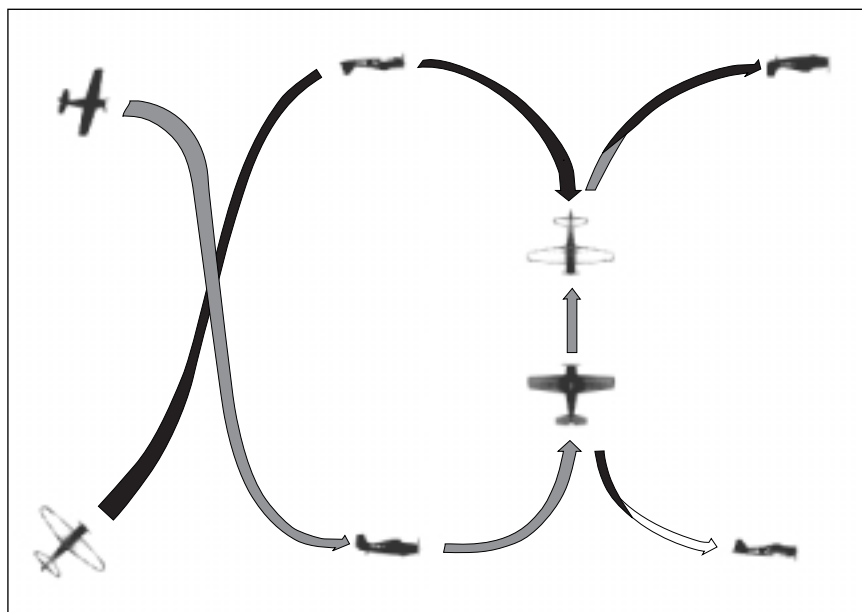

Scissors fight

The scissors is really just a series of banked turns, as tight as possible. Whenever the opponents can get a clear shot on each other, they blast away for all they're worth. Firepower counts in this sort of fight, but maneuverability is more vital.

THACH WEAVE

The Thach weave (no, it's not misspelled—it's named after Lt. Cmdr. John F. "Jimmy" Thach) is an American tactic developed by fighter pilots for defeating the Japanese Zero fighter. If an American fighter got trapped in a one-on-one dogfight with a Zero, the Japanese aircraft had a big advantage. Sticking to hit-and-run tactics helped, but with the Zeke's extraordinary climb and maneuverability, the IJN pilot could usually draw the hapless American into a close-quarters fight.

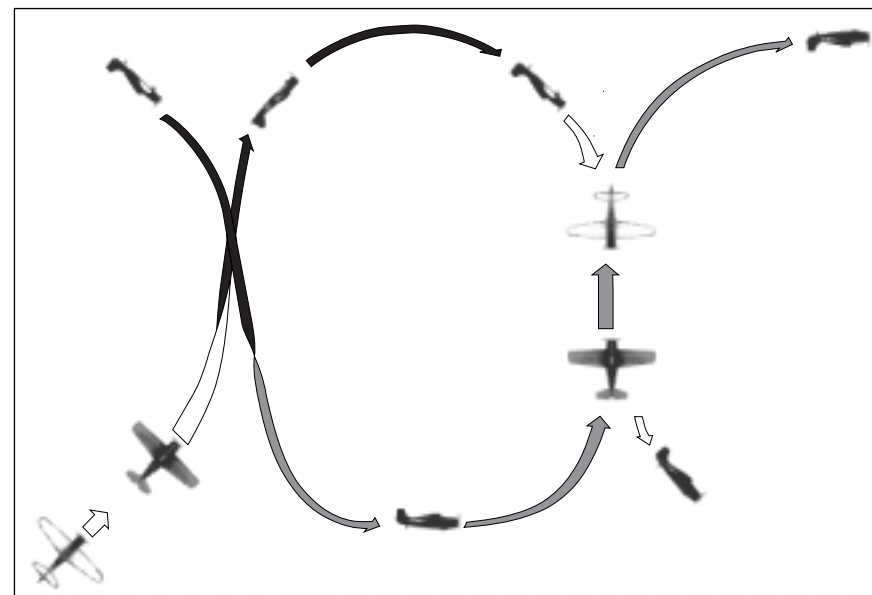

Thach weave

Though invented for use against the Zero, a Thach weave works just as well against almost any enemy fighter. The key to the weave is teamwork. Once an enemy gets behind one of your compatriots, you've got to start the weave pretty quickly. The fighter pilot who's acting as "bait" has to know his stuff, too. He needs to survive long enough (with the enemy right on his tail) for the "hook" pilot to get in and do his job. Executed correctly, the Thach Weave is a deadly trap with little or no real hope of escape.

ADVANCED MANEUVERING

As you fly and fight, you will almost certainly outgrow the small group of simple maneuvers presented in earlier sections. Like any pilot, you'll develop your own favorite moves and tricks. Some will be combinations of those basic maneuvers, and some will be completely new ideas. As happens in real life, most of these will be pretty, but entirely useless in combat. The few that do continue to work are not to be underestimated. Whenever you go head-to-head against the enemy, it's going to be your bag of tricks against his. Generally, the fuller bag will win.

The advice and the few maneuvers presented here are a little more advanced than those presented earlier. Add them to your arsenal, practice them, and use each as you can. Keep in mind, however, that any opponent you face may also know all of this. Your invented maneuvers, once they've been tested and proven in combat, are likely to be more valuable in the long run than anything you learn here.

The "Tightest" Turn

It would be a vast understatement to say, "The ability to make tight turns is often important in air-to-air combat situations." In a scissors fight, a one- or two-circle contest, the Thach Weave, and many other, nameless predicaments, the pilot who brings the nose around most quickly is usually the pilot who survives. So, how do you make the best turns your plane is capable of?

First, you should recognize that the "tightest" turn—the one with the smallest radius—is *not* the turn you want. If your airspeed is low enough, it is possible to turn 180° in a very small area, as in a wing over. Problem is, at that speed the turn takes a long time to complete (and you present a great target throughout).

The other extreme is the "fastest" turn. At top speed, your plane should whip around any turn quickly, right? Of course not. If it was that easy, rudimentary computers would have replaced pilots long ago. Taking a turn at high speed does make you less of an easy target, but the turn is very open and uses up a lot of sky. The turn you want to execute in combat is the one that maximizes the *degrees of turn per second*—the quickest turn.

Of course, every model of aircraft (and every individual plane) is different and thus has different characteristics in a turn. It is impossible to give exact instructions for getting the quickest turn out of any real plane. The planes in *European Air War* are simulated, however, and are actually more similar than they are dissimilar. There are some general considerations that will get you close to the quickest turn for each plane. Tweaking the last second or two off your turn is up to you.

For every plane, there is a certain airspeed at which it is capable of its quickest turn. This speed is a compromise, a balance between turning radius and forward movement of the aircraft. The problem is this: the faster the plane is moving, the faster it will get around the turn, but at higher speeds, the turn becomes more open and, therefore, longer. At slower speeds, turns are less open (shorter), but the plane traverses the turn more slowly. Somewhere in the middle is the airspeed at which you get your best turn. Any faster, and the turn will open up and take more time; any slower, and the plane won't get around it as quickly or might even stall.

That airspeed is between 220 and 280 mph for every one of the pilotable aircraft in *European Air War*. Note that you will lose airspeed during the turn, so you may want to start your turn a little above this perfect speed and "fall into it." Bank 80 to 90 degrees and pull back on the stick. (Don't forget to coordinate the rudder.) Increase throttle as necessary to keep your speed close to the magic number. Most important—and this will come easily only after you are familiar with the plane—do not pull back so far on the stick that you stall in the turn. Chances are good that your opponent would not let you survive to recover from it.

One more subtle effect that you may want to be aware of is the difference in airspeed loss according to your speed through the turn. The more slowly you are moving, the tighter the turn will be. The tighter the turn, the larger surface area your plane presents to the relative wind. Drag in a slow, tight turn will take away a larger percentage of your airspeed than the same drag in a fast, open turn. In the fast, shallow turn, your plane presents a smaller surface to the relative wind, and thus a lesser percentage of airspeed is stolen by drag. In the quickest turn, at a moderately low speed, the loss is average. If you do take the turn at just above the best airspeed, you may save yourself a little speed. Why you might want to do this is covered in the discussion of energy management.

Turning With the Rudder

Now we turn from some of the most efficient turning techniques to what is probably one of the least efficient, aerodynamically speaking. Though it is no longer taught as standard practice (at one time it was), it is quite possible to change the direction of an aircraft using only the rudder. The principle and practice are fairly straightforward. The first question we need to confront, though, is why anyone would ever want to turn this way.

Turning with only the rudder is slow and ungainly. It imposes forces on the plane that make it pretty easy to lose control and drop into a spin. Clearly, this is not the method of choice for pilots who want to see their next birthday—or is it? Professional pilots steer with their rudders every day. In fact, most would probably say that it's nearly impossible to land well without doing so. During the final few seconds of an approach to the runway, no intelligent pilot uses side movements of the stick. (The wing tips, when banked near touchdown, have a nasty tendency to hit the ground.) Tiny last-minute changes in direction are often necessary to avoid touching down at an angle to the runway, and these moves must be made with only the rudder for control. Other than fine-tuning a landing, however, the rudder is best used along with the ailerons for coordinating three-dimensional maneuvers—not for turning.

What happens when a pilot steers with the rudder? If all of the other controls are held steady, left rudder quite simply results in yaw to the left. (We'll use left rudder as an example; you can extrapolate to figure out the effects of right rudder.) Essentially, the extra drag caused by the extension of the rudder surface retards the forward movement of the left side of the aircraft, causing the whole plane to yaw in that direction. This yaw changes the direction in which the nose is pointing, and therefore shifts the direction of the propeller's thrust. For a short time, the plane will move at an angle—skidding—with the propeller impelling it to one side. The combination of the inertial skid and the forward thrust of the propeller results in a curved path of movement.

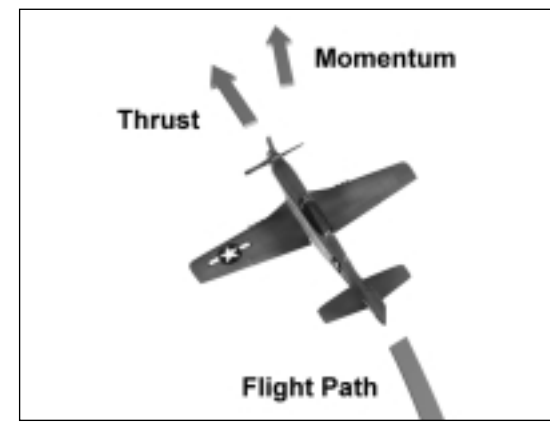

Forces on the aircraft in a skidding turn

This curving movement is all well and good if the rudder is held for only a short time. The aircraft does change direction, though slowly and skidding all the while. (Pilots generally do not approve of skidding, as it is an inefficient and graceless way to fly, and it causes a big loss of airspeed.) For small directional changes when landing, this is quite enough. There are dangers, though, for anyone incautious enough to continue to hold the rudder.

When the plane is skidding, one wing is further forward than the other in relation to the relative wind. That forward wing has more lift than the other wing, especially since the fuselage blocks some of the airflow that would normally hit the back wing. The difference in lift causes the aircraft to roll (bank) in the direction of the yaw (left). This secondary banking will tighten the turn and slow the plane. No problem, right? It just makes the plane turn more. Well, there's a catch. Now that the plane has banked, any further yaw caused by holding the rudder is no longer purely horizontal. The nose dips toward the ground. Airspeed starts to increase, the plane rolls a little more, then yaws a little more, and so on. Much more quickly than you might think, the aircraft is in a tight, fast, corkscrew dive or even a spin.

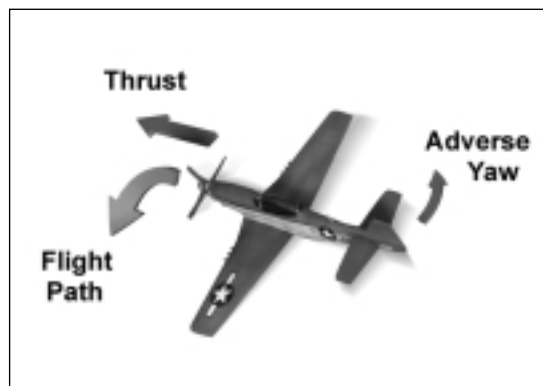

Forces resulting in a corkscrew dive

So if your ailerons are not working, make sure that you never hold a rudder-only turn for too long. Otherwise, you're going in for a dirt bath.

Escaping a Scissors Fight

One of the first rules of dogfighting is: *Never get into a turning fight against a more maneuverable aircraft.* The operative word here is *never*. It's hard to overstress this. *Don't do it.* Ever. Period. There are no exceptions.

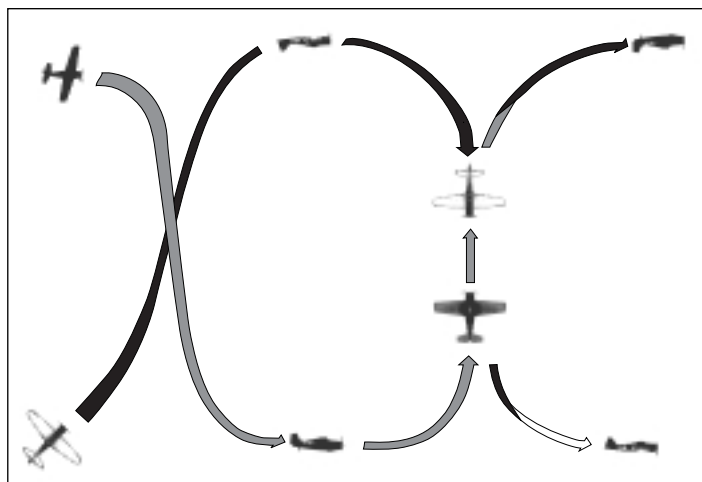

The Scissors

Now, assuming you've gone ahead and done so, you are probably going to get shot down. If you stay to fight, you're history. If you try to disengage, you're toast. There is no reliable way to escape.

What this little section is about is a more unusual situation. Let's say you've gotten into a scissors-type turning fight against a plane that is less maneuverable than yours or just about evenly matched. After you're committed, something about the setup changes, leading you to decide that putting some distance between yourself and your opponent is a good idea. (For example, you find out you've been suckered in by a Thach Weave.) Even if your maneuverability is better than your opponent's, breaking off is going to give him at least one free shot at your six. What to do?

Well, the fact is, there's one point in the scissors when you can effect a pretty clean escape. ("Pretty clean" means you'd better get it right, or you'll end up with a normal, vulnerable break-off.) At the exact moment when the two planes cross paths, your enemy cannot see what you're doing. He has to assume, for a second or two, that you're turning into the next leg of the scissors, just as he is. If, at that precise moment, you invert instead and dive into a Split-S, you can get away clean.

Before you actually pull this maneuver, there are a couple of important things to keep in mind. First, where are all the other planes? Situational awareness is absolutely vital in this case. Since at the end of your escape, you're not going to be in a very good energy state, you want to end up in friendly skies. The Split-S is going to reverse your direction of flight, so make sure there's nothing nasty behind you when you start into it. The other thing to consider is the angle of approach between your plane and your opponent's. The larger this angle is (nose to nose is 180°—as big as it gets—but if you're in that situation, you'd better be filling his engine with lead!), the better your chances of escape. The longer it takes him to get turned around toward your new heading, the better.

Remember, in the first part of the Split-S, you gain airspeed rapidly. It will take only a few seconds for your opponent to realize what you're doing, so you have to gain all you can get from those seconds. Ignore the decision point of the maneuver; do not roll at all. You're already in position to make the enemy's turn take as long as possible, and that's exactly what you want. By the time he gets pointed in your direction, you want to be far away or already coming back.



You can use your newfound airspeed in several ways. One is to go like a bat out of hell for distance, in the case when you need to escape. Another option is to throttle up and carry the extra energy into a zoom, gaining plenty of altitude. This gives you the advantaged position, from which you can come around for a fast, slashing attack. Whatever you decide, at least you've left the scissors, which was the immediate goal.

SOME FURTHER ADVICE

Here's some more information for those of you who want to learn more about flying, fighting, and landing. Just keep in mind that all of this advice is a generalization; none of it is reliable in every situation. What you learn in the sky should always supersede what you learn from the books.

TACTICAL QUICKIES

This section is probably the closest thing to a BFM (Basic Fighter Maneuvers) tutorial in this book. Of course, these are only guidelines. Experience and the advice of other pilots are your best teachers.

Fighter vs. Fighter

This is pretty much the meat of any fighter pilot's career: fighter vs. fighter dogfighting. It's beyond the scope of this manual to cover fighter tactics in depth, but we can offer a few pointers. One thing you might want to keep in mind is that just about every pilot has his or her own opinions about what's important up there. If you ask, most flyboys will gladly share them.

We've already covered the hit-and-run and escaping a scissors fight, but there are three more bits of tactical lore that may prove useful.

A *One-Circle Fight* is something you'll find yourself engaged in fairly frequently in one-on-one situations. In essence, this is a turning contest like the scissors, but one in which both aircraft are more committed to the fray. In the one-circle, the two planes are turning in different directions, but in the same space—one clockwise and one counterclockwise. Both are vying for the earliest shot at the other as their paths cross, and neither can break off without giving the enemy an easy target. Sooner or later, both planes slow down to get a tighter turn. The plane (or pilot) that can turn most tightly will usually win, though firepower is also a strong factor. If the turning battle is a draw, whichever plane is the first to slow down too much will either stall or be forced to trade altitude for speed, giving the other pilot the advantage. If you're high enough, you can usually use a sudden Split-S to escape from the circle.

The *Two-Circle Fight* is also common. In this case, the two aircraft are committed to a turning fight, but they're turning in the same direction. Thus, each plane is making its own circle. As in the scissors and the one-circle, the pilots fire at each other at every pass, with the win normally going to the one with the fastest turn. Firepower can also be a big factor in these fights. Breaking off is easier in the two-circle situation, but still hazardous.

The high and low *Yo-Yos* are maneuvers that can help you maintain your energy when you need to close for a shot. Let's say you're above and behind a bandit moving away from you at the same speed (or faster). You go into a shallow dive, trading some altitude for airspeed, then pull up again to convert that speed back into altitude. At some time during the climb, your target will be right where you want it to be. Fire away, then repeat the maneuver as necessary. This is the low yo-yo. The high yo-yo is the reverse maneuver, used when you're below your target or moving faster. Some pilots will combine the two, firing on the way up *and* the way down. When it's possible, this is the more efficient method.

Fighter vs. Bomber

Bombers are really big, slow targets. Therefore, they're easy to gain advantage over, easy to hit, and easy to underestimate. The thing to remember is that you can't approach a bomber like you would a fighter. You *do not* want to wind up directly behind a bomber. There's a tail gunner in there. Keep in mind that there's a fan-shaped area behind the bomber that you want to avoid.

Approach bombers from the side, top, and bottom (with the sun at your back, if possible). The exception is the B-17; you want to come at that one nose-on. Use your speed advantage to the fullest—never give the pilot a chance to turn on you while you're in range. Just sweep in, pelt the fuselage with holes, and zip away to line up another pass. Generally, bombers on a run don't have much room to maneuver, so they'll not make things too hard for you. The toughest part of shooting down bombers is getting through the escort.

If you run into a heavily escorted group of bombers, you can sometimes use the bomber's firepower to your advantage. If you notice an enemy fighter on your tail, head toward a bomber, take a few shots, and turn away. Hopefully, some of the bomber's anxious gunners will hit the tailing fighter.

AAA

Dealing with enemy fighters is generally your biggest problem. No matter whether you're on the offensive or defensive side of the fight, though, you still have to fly through the flak—the Anti-Aircraft Artillery (AAA). This stuff brings down more pilots than anyone wants to think about. There's really nothing you can do to guarantee that you'll get through unscathed, but knowing a little about how it works might spark a few ideas.

The volume of effective AAA coverage forms a squashed dome of approximately 25,000 yards horizontal radius and 40,000 feet vertical height around each AAA emplacement. These domes usually overlap and combine to form an almost continuous coverage over a target area. The most obvious tactic for minimizing your exposure to AAA is to fly above 40,000 feet for as long as possible. In the final stages of any attack run, though, you need to drop down in order to do any damage.

The gunner at the controls of any AAA battery can't just loft shells up at random and hope you fly into them. Every time he pounds off a round, he first calculates a firing solution based on the altitude, direction, and relative velocity of the target (you). Since these shells aren't self-propelled—muzzle velocity is all they get—they can take quite a while to cover the distance. So here's the punch line: every shell that is flying toward your aircraft was aimed several seconds ago, based on your altitude, direction, and speed at that time. Therefore, don't stand still. Flying in a straight line is the most risky tactic of all.

ALTERNATIVE DELIVERY TECHNIQUES

Even in a fighter, you often have opportunity to drop bombs. The standard dive bombing run is pretty effective, but it does have drawbacks. Throughout the actual dive, you're vulnerable to any determined attacker—your aircraft doesn't have a lot of maneuverability at the speeds it can build up to in a dive. Add to this the fact that most fighters aren't built to sustain a steep dive, and that the stresses—or AAA—can tear them up, and you understand why using a fighter as a bombing platform can be prohibitively risky.

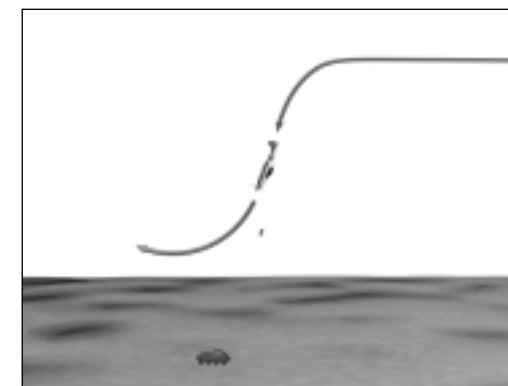

Standard dive

Over the years, fighter pilots have developed other effective ways to deliver their packages.

Cuban 8 Bombing

The *Cuban 8* is not really an alternative to the standard dive bombing technique; it is merely an "advanced" version—an elaboration on the details of the run. Treating the dive bombing run as though it were a modified Split-S adds adaptability to your technique. You'll enter the dive more smoothly and have a much better chance of leaving it alive.

The first difference from the standard bombing dive comes right at the beginning. Many of you will already have figured out that going into a steep bombing dive right side up causes a redout. The inverted entry that you would normally use to go into a dive is safer. There's no reason not to use it in the case of a bombing dive. The key problem is the AA gunners. If you go into a truly vertical dive directly over your target, you're playing right into their hands, and your chance of survival is minimal. Here's where the Cuban 8 comes in. After you invert, drop the nose to exactly the normal dive angle you'd use. When you get to your angle—without the risk of redout—steady the plane and roll over. Works every time.

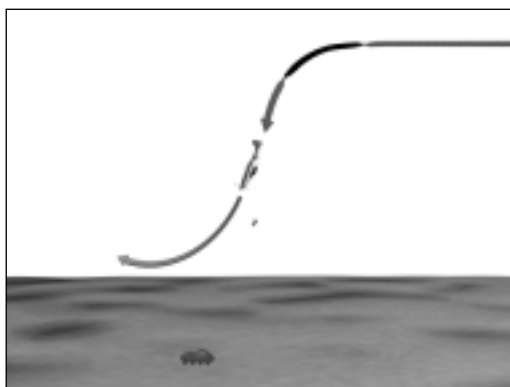

The Cuban 8

One alternative version of the Cuban 8 is a modified loop over. Fly past your target lower than you expect to start your dive, then pull up into the loop. At the top of the loop, when you're pointed back in the direction of the target, use the same Cuban 8 dive angle technique to start your dive, then roll right-side up.

The actual dive is no different from the standard vertical dive. However, there's something you can do toward the end of the dive that will greatly increase your chances of making a clean getaway. The AA gunners who are trying to destroy your plane cannot merely aim at you and fire; they have to lead you, aiming along your supposed flight path. They know as well as you that when you pull out of the dive you will be flying in the direction that your head was pointing when you pulled back on the stick. (Remember the decision point of the Split-S?) They're watching you. If you roll the plane around a little during the dive (fighter pilots call this 'jinking'), you can quite effectively throw their aim off. Just be careful that you don't throw your own out of whack as well.

Before you release your bomb load, choose a direction. Immediately after the drop, roll quickly to that direction and pull out. This last-second roll further disturbs the aim of the AA gunners. Every little jink helps.

Popping Up

The term 'pop-up' is used to refer to two somewhat different tactics used by modern combat pilots. Both involve a type of close-to-the-ground flying that was not practiced by combat pilots until very late in the Second World War. Modern pilots know it as "Nap of the Earth" or NOE flight. One type of pop-up is primarily a helicopter technique, which is also quite suitable for propeller-speed strafing and rocketry. The other is a form of low-level dive bombing, which can be used by most bomb-laden fighters.

The first form of popping up—the helicopter technique—is most effective when combined with self-propelled and self-guiding weapons. In the 1940s, weapons with internal guidance systems were still science fiction, on the verge of becoming reality. The rockets were about as self-propelled as an air-launched weapon got. Give this tactic a try; if it doesn't work for you, discard it. If it does work, use it.

The first thing you need is a hill or a ridge. That's right, you can't use this tactic over flat, open ground. The basic notion is that having a large chunk of dirt between you and your target prevents two things. One, it lowers the chances that the defenses will be alerted to your presence. Two, it serves as a barrier to anti-aircraft fire. What you need to do is fly in low and fast, sticking to the lay of the land (NOE). If you're doing it right, your altitude will be less than that of the hilltop. Now, obviously, this hill also keeps your bullets (or rockets) from getting to the target. (It will also wreck your plane if you continue at your current altitude.) This is where the popping up comes in. If you keep following the nap of the Earth, you'll climb up over the hill. As soon as you clear the top, level off and find your target. (Note here that the closer the hill is to the target, the bigger advantage the element of surprise will give you.) As soon as it's in range, dive in and start shooting.

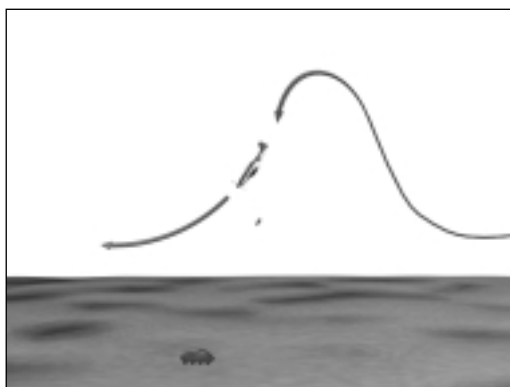

Pop-up Bombing

Pop-up bombing is an altogether different tactic. For one thing, you don't need hills (or even land). For another, it's a bombing technique, not well suited to strafing and rocketing.

Start out moving fast at a fairly low altitude. (You can't pop up unless you're down.) Essentially, you should be at the altitude at which you're going to drop your load, and you need to have enough energy (airspeed) to climb at least 2000 feet. When you get close to your target, go into a steep climb—10° more upward than your dive angle will be downward. You'll lose most of your airspeed, and you should gain between 2,000 and 3,000 feet. At the top of your climb, roll toward the target at 90° plus your intended dive angle. For example, if you expect to use a normal 70° angle, you would roll 160°. When the target is dead ahead and you've gotten to the dive angle you desire, roll right-side up and steady the plane into a standard bombing dive. From here on out it's just like a normal bomb run, except that you're moving relatively slowly. This gives you better control and accuracy, but you'll need to gain some speed to make good your escape.

Level Bombing

Level bombing is the only effective way to deliver a torpedo. Level bombing offers a stable platform for dropping "sticks" of tens or hundreds of bombs over mainland industrial targets. For single-shot bomb drops requiring precise targeting, level bombing is practically useless.

Okay, it's possible to imagine a few situations when level bombing could be a good option in *European Air War*—for instance, maybe your elevator has been shot off. The main problem is that level bombing is less precise than dive bombing; it's much more difficult to hit your target. Another concern is that flying level over a target is a really good way to get yourself torn apart by flak. Nevertheless, there might come a time when necessity corners you, and you need to know how to bomb from a level attitude. To train for such an occasion, your best bet is to practice on targets which have no anti-aircraft weaponry.

The approach is not complicated; you simply fly toward the target. If there is AAA fire, dodging from side to side is encouraged. The altitude at which you approach should be dictated by your grasp of the physics involved—the physics of the trajectory of a released bomb, that is. The physical laws applicable to falling bodies will also provide a good guide as to when you should drop your ordnance for best effect (to hit something).

Slowing due to the resistance of the air is pretty much negligible in the case of these small, aerodynamically designed bombs. Therefore, each bomb will fall along the parabolic course dictated by gravity and forward momentum. As a rough guide, the bomb will hit the surface at the point you are flying over when it impacts (assuming you have continued flying straight). You need to learn how to judge two things. The first is how long it will take you to fly from your present position to a point directly over the target. The second is how long it will take the bomb to reach the surface from your current altitude. When these two numbers are the same (momentarily), that's when you should drop your payload. In aircraft of this sort, both of these judgments are built through experience and cannot be reliably taught. A little physics, however, allows us to compile an approximate guide to drop times.

Altitude (ft)	Time (sec)
10,000	24.5
9,000	23.2
8,000	21.9
7,000	20.4
6,000	18.9
5,000	17.2
4,000	15.3
3,000	13.2
2,000	10.6
1,000	7.4

Glide Bombing

The first aircraft to drop bombs (other than those thrown by hand) were glide bombers. The development of explosive anti-aircraft fire was supposed to render this time-worn delivery technique virtually obsolete, but pilots continued to use variants of it well into this war.

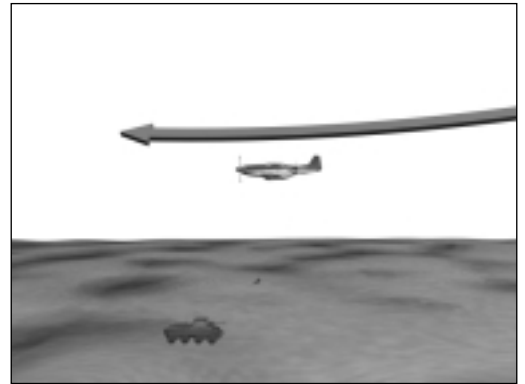

Glide bombing

Although you give yourself more time to line up the shot if you glide it in, you also spend a terrific amount of time exposed to enemy flak. Generally, it is unwise (to say the least) to attempt glide bombing except against undefended targets. Even then, the proximity of your plane to the explosion of the impacting bomb is a grave threat. If you don't get out of the way fast enough, you'll get your wings blown off and go ballistic.

Approach your target by the direct route, in a shallow dive at high speed. Remember that the bomb has only as much force as your airspeed gives it. Also keep in mind that you will have a very short time to get out of the way before that baby goes off, and speed is good for escaping. When you're close enough that you cannot possibly miss, but not quite so close that you can't pull up, loose the projectile. If you've done everything right, the bomb will continue along your flight path long enough to reach the target.

As soon as you've let go of the package, you have three options, each of which has its advantages. First, you can pull up just enough to miss colliding with the target, relying on your airspeed to carry you out of shrapnel range. This works fine if you're going fast enough, but you probably aren't—the bomb is moving as fast as you are, right? Second, you can pull back hard on the stick and try to climb (zoom) out of blast range. This technique will work about half the time. The problem is the loss of speed as you enter the zoom; sometimes it's enough to keep your plane in the danger area. The third (and probably best) option is to bank hard to either side and pull the stick far back. This should curve your plane quickly out of harm's way. Since you lose less airspeed in a bank than a zoom, your plane will leave the blast area just a smidgen more quickly.

Lofting

Lofting a bomb—also called 'lobbing' or 'tossing'—is much less dangerous than gliding it all the way in. Unfortunately, it's also much more difficult to do with any accuracy. Lofting is effective primarily when delivering an unpropelled weapon that has a large blast radius or area of effect. To deliver one of the "dumb" bombs in *European Air War* accurately, you'll need to let go of it fairly close to your target—although not nearly as close as you do when glide bombing.

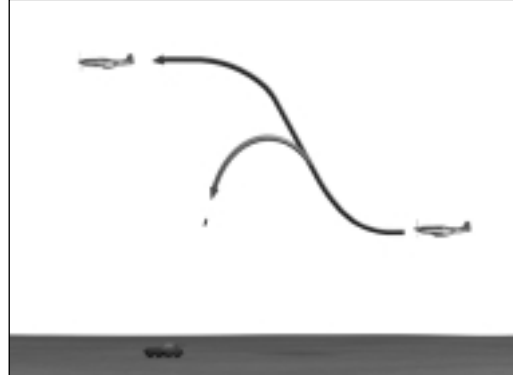

Lofting



The key difference between the loft technique and a glide drop is the tangential release. As pilot, you begin pulling up into your escape zoom *before* letting go of the payload. Drop your egg when your nose has moved approximately halfway to the zenith (45° above the horizon—the zenith is straight up). Since the bomb leaves the cradle with the same momentary direction and speed of flight (velocity vector) as your plane, it will fly off at a tangent to your vertical curve. As long as you release at less than (roughly) a 50° angle, the subsequent upward momentum of the projectile will add to the horizontal range of the bomb. It will also give you more time to get out of the way.

Physics gives you a good idea how far a bomb will travel from any particular release angle. Unfortunately, it's pretty useless knowledge, since in reality you never know the exact angle. Practice will give you a much better feel for it.

LANDINGS

European Air War doesn't require that you ever land your plane. Once you've accomplished your mission objective, whatever it happens to be, and returned to within 50 miles of your base, you can quit the mission. That way, you shorten the long flight home. You also avoid having to land. That's fine if you're in a hurry to get to your next mission, but if you have ammo left and you're in enemy territory, there might still be targets of opportunity between you and your home runway. Allied fighters escorting bombers (especially the P-52s and P-38s) wreaked havoc on German railways and supply convoys by unloading their guns on the way home.

Keep in mind that the planes in *European Air War* are all equipped with the same standard landing gear configuration—nose-high with a short tail wheel. This setup is great for take-offs, but is much more unstable during the landing than the modern tricycle gear. These "tail-draggers," as they've come to be called, are much more likely to lead you into a ground loop than modern aircraft.



Step 1: Lining Up

The first thing most inexperienced pilots do when they want to land is also the first thing they do wrong. If you fly in from the wrong direction or start your approach too close to the runway, you've already doomed yourself to a failed landing attempt. (If you don't yet know the layout of the landing field, fly a pass over the runway to check things out. You need to know in what direction the runway runs.)

Start your landing run at a good distance from the strip. Most pilots like to have at least the 3 miles that the *Game Player's Guide* calls for. At that distance, you should be able to see the runway, which is necessary for judging your angle of approach. You also should have plenty of time to lose most of your altitude, bleed off any excess speed, and make the necessary adjustments to your flight path.

Unless you know the descent characteristics of your plane pretty well, you'll want to fly a *base leg* to lead into the actual approach. A base leg gives you the chance to judge the descent slope you're going to be flying. It also allows you more time to get your speed and altitude right. You start the base leg at the same distance away from the runway, plus a mile or two (or more) off to the left of the point where you plan to begin your landing approach.

Start your base leg at an altitude a little over 1,000 feet, flying roughly halfway between the plane's normal cruising speed and its level stalling speed. Extend the flaps completely. (Note that this will result in a temporary lifting of the aircraft and will drastically lower the plane's *effective* level stalling speed.) Use gentle back pressure on the stick to maintain a level attitude. Presumably, this will cause you to sink (lose altitude) at a regular rate. If not, cut back on the throttle until you do start to sink. Now comes the hard part.



You need to estimate the *angle* at which you are losing altitude. If you were landing an actual aircraft, you could use visual clues to do so. In *European Air War*, you also use visual cues, except that it's more difficult. Watch the visible surface (below the horizon) in front of you. After a short time, you will be able to differentiate between the three types of apparent movement taking place. Things near the top of the view will seem to rise toward the horizon, while things near the bottom will seem to slide downward and toward you. Ignore these things. In the middle will be a narrow area where nothing moves up or down, relative to the horizon. This area is where you would touch down if you continued exactly as you are flying. Note how far this is from the horizon, then look out over your left wing. If the near end of the runway is the same apparent distance from the horizon, your rate of descent is perfect. Of course, this method is less than precise, and you will need to make adjustments to your descent path as you go.

If your descent path is wrong, it's pretty easy to correct. To make your path steeper—that is, to drop more quickly and aim at a touchdown point nearer (farther from the horizon) than your current one—point the nose up a little. At first, it may seem as though you're actually getting a shallower descent, but this is a temporary effect. As long as you don't touch the throttle, your descent will get steeper and you'll lose a little speed. If you have a Rate of Climb indicator in your plane, the ROC reading will prove the difference in the angle of descent. If your path is already too steep, point the nose down a bit. This will increase your speed and shallow your descent.

Having set your aircraft in the correct descent angle, you need only wait until you are aligned with the end of the runway. Turn toward the landing strip and settle into the same descent as before. Once you're lined up facing the runway, you should have your altitude, speed, and distance balanced for a proper and uncomplicated descent slope.



Step 2: Power Descent

This is the easy part. As you gradually settle toward the runway, be alert for any minor changes you need to make to keep your descent angle where you want it. From this point on, you don't want to make any sudden or drastic control changes (unless you abort the landing, of course). Make sure that you're lined up correctly with the runway. Last-minute changes to your direction of approach are not recommended, as they tend to be difficult and dangerous.

Lower your landing gear. The extra drag this causes will slow you down and make your approach noticeably steeper. You can compensate for this using the same rules as in Step 1. Unless you are about to stall, don't increase the throttle setting. You need to keep enough speed that you have good control of the aircraft, but you also want to be going pretty slow when you touch down. Your indicated airspeed (IAS) should certainly be less than 100 knots.

Even if you have trimmed your rudder to compensate for engine torque, you'll still have to keep an eye out for a tendency to turn to the left. In fact, the lower your airspeed gets, the greater the effects of torque will be. In extreme cases, you could find yourself holding full right rudder against the engine by the time you touch down.

Step 3: Final Approach

As you start to get really close to the ground, the tiny corrections come faster and faster. Don't worry. It's just like dealing with a lion; if you remain calm and don't make any sudden moves, you'll probably live through the experience. Once you're within a few hundred feet of the runway, do not use your ailerons at all unless you absolutely have to. Touching down with your wings at an angle is a really effective way to kill yourself—and everybody on the landing field. If you must straighten out your approach, use the rudder. It's less efficient and a little slower to slip and skid into position, but it's far safer in the long run.

The methods of changing your descent slope that you used before will still work now. If you need more drastic changes in your slope than tilting the nose will give you, however, you've probably botched the landing. A combination of throttle and elevator control can often compensate for a bad approach, but if you have enough fuel, go around and try again.

When you're on the mark and ready to touch down, slow down as much as you possibly can without stalling. You may have to lift your nose to stay aloft, and the runway may not be visible. Don't panic; it isn't going anywhere.

Step 3^{1/2}: The Go-around

If you decide that you've botched a landing, you must abort and try again. The first step *absolutely must* be to ram the throttle to full; nothing else you can do is more important. You cannot stop the landing, regain altitude, or even control the plane without getting your airspeed up away from the stalling zone. So, as soon as you decide to do a go-around and restart your approach, go to full throttle right away.



Sometimes a go-around is your best option.

Now raise your gear. This will lessen the drag on your plane and give you a little more speed. You'll need all the speed you can get for the next step.

Pull back very gently and not very far on the stick. Do not bank at all. You want to climb gradually, as if you just took off. Remember that a few seconds ago you were about to stall, and the plane is still very near the stalling point. If you try to climb too quickly by pulling the stick back, you're going to stall and hit dirt. If you bank, you will steepen your angle of attack, stall, and hit dirt.

Once you get some speed and altitude under your belt, you can bank around for another try at it. Treat this approach just like the first one, except correct whatever you did wrong that time. Don't forget to put your gear back down at the appropriate time.

Step 4: Flare and Touchdown

You're dropping toward the runway near stalling speed. Your flaps are extended, gear down, and your nose is up. The ground is coming up fast. Everything is A-okay. Now what?

Well, you just continue this way until your wheels touch dirt. That's all there is to it. Some pilots perform a maneuver known as a *flare*, but it isn't really necessary unless the runway is far too short.

A flare, reduced to its simplest form, is merely an intentional stall. As you approach the runway, your flight profile is already hovering near a stall situation. When you're ready to land—at approximately 100 feet for heavy aircraft and 50 for lighter ones—pull back on the stick just enough to put your plane over the edge into a full stall. This action should take just long enough that the stall occurs less than 20 feet from the surface of the runway. The aircraft will drop onto the runway with the least possible forward speed.



Step 5: Stop the Plane

The moment you touch down, immediately cut your engine and apply the wheel brakes. Let go of the stick entirely; you can only get yourself in trouble with it at this point.

There are just two more things to worry about. The first is: You came down too hard and the plane bounces off the runway. As usual, your first instinct is wrong; don't force the nose down. If you just hold the stick steady, you'll stall again and touch down again, more lightly. If you were to push forward and nose down toward the runway, that's exactly how you'd land. Nose landings are pretty funny-looking, and a pilot who engages in one gets fitted for a dirt shirt.

The second worry is: here you are on the ground, still moving, and you find yourself heading right off the side of the runway. This is not good. Your first instinct is probably to grab the stick and haul it over to one side. However, if you do this, you will likely perform what is known as a *ground loop*—one of your wing tips hits the ground and the plane flips over.

What you really meant to do was to use the rudder. As soon as your wheels are on the ground, the ailerons (and, thus, any sideways movements of the stick) become useless. At the slow speeds involved in landing, the rudder is quite useful for steering the aircraft, especially once it has touched down. Right rudder will steer you to the right, away from the left edge of the runway, and left rudder will take you to the left—away from the right edge of the runway.

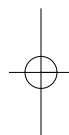

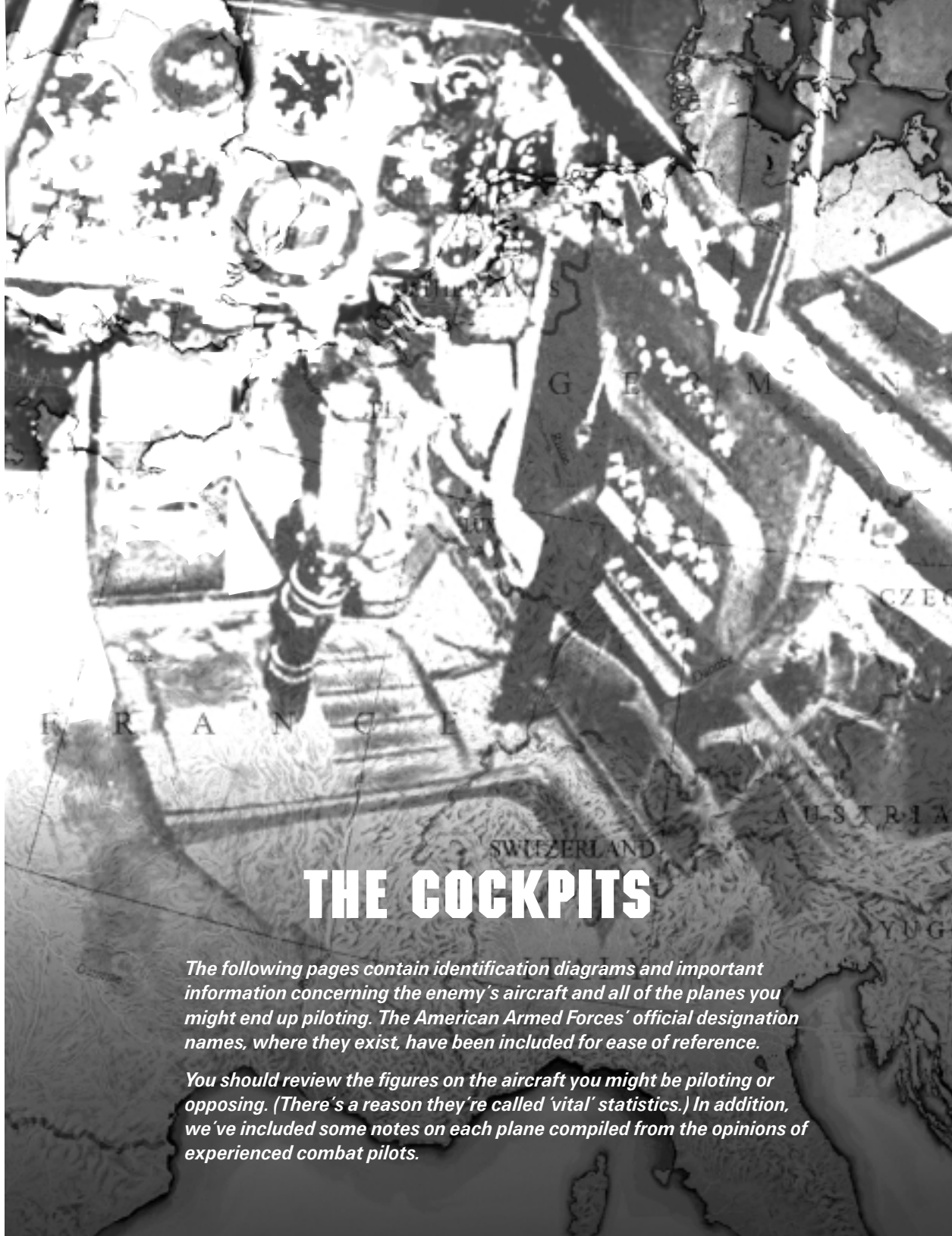

THE COCKPITS

The following pages contain identification diagrams and important information concerning the enemy's aircraft and all of the planes you might end up piloting. The American Armed Forces' official designation names, where they exist, have been included for ease of reference.

You should review the figures on the aircraft you might be piloting or opposing. (There's a reason they're called 'vital' statistics.) In addition, we've included some notes on each plane compiled from the opinions of experienced combat pilots.



BACKGROUND

At the outset of World War II, the air tactics in use closely resembled those of the previous world war, but during the ensuing years of conflict, they underwent extensive change. The change in tactics seems minor, however, when compared to the dramatic transformation that the aircraft of the world's armed forces went through. Countries went from using light and fragile planes with limited range, armament, and payload to flying the world's first jet fighter, the German Me262. In the process, specialized warplanes sprang up, including craft outfitted for night flying, long-distance precision bombing, escort missions, and of course air-to-air combat.

Air power became one of the critical factors in determining the outcome of the war. Control of the skies meant the ability to bomb the enemy's centers of communication and industry and to thereby slow or disrupt production of materials essential to the war effort. With air superiority, countries could also provide much-needed support to their forces at sea or on land. Either side's success in the air was far from a foregone conclusion, so closely matched were all the aircraft in the battle.



UNITED STATES ARMY AIR FORCE

During World War I, the American Air Service lacked any fighter planes of American design and was forced to use aircraft from France and Britain. While that was no longer true in the years leading up to the start of the Second World War, American fighters were—with notable exceptions like the P-39 and P-40—still far from overpowering. As the United States was soon to discover, successful military operations called for a greater diversity of warplanes.

The British, too, found themselves in the position of needing new and more specialized aircraft to cope with the German threat. In 1940, they requisitioned an American aircraft built with a heavier (and thus more powerful) engine. Eventually, this became the P-51 Mustang. So began the quest for warplanes individually adapted for specific roles in battle.

The United States has since become a world power in aircraft design and production, supplying planes not only to its own armed forces, but to those in many other nations as well. The fighters you fly in *European Air War* helped usher the United States into this age of aerial superiority.

THE COCKPITS

LOCKHEED P-38 LIGHTNING

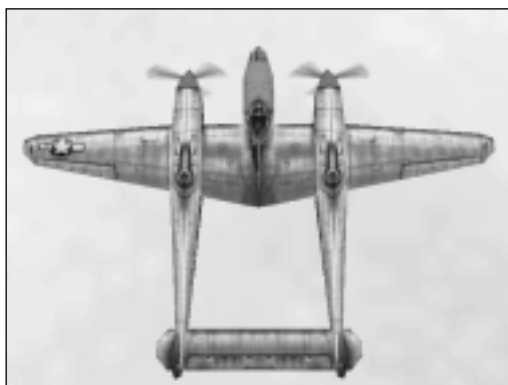

- Fixed Weapons: 4 nose-mounted .50-caliber Browning machine guns
1 nose-mounted 20 mm Hispano cannon
- Ammunition: 500 rd/gun (mg)
150 rd (cannon)
- Firing Rate: 750 rd/min (mg)
450 rd/min (cannon)
- Span: 52' 0"
- Length: 37' 10"
- Height: 12' 10"
- Engines: 2 Allison V-1710s-89/91

	Model H	Model J
Max. Speed	402 mph	414 mph
Cruise Speed	250–320 mph	250–320 mph
Ceiling	40,000 feet	44,000 feet
Combat Radius (with drop tank)	275 miles (2,260 miles)	350 miles (2,260 miles)
Fuel Capacity	300 gallons	410 gallons
Wing Area	328 sq. ft.	328 sq. ft.
Horsepower	1600 hp (x2)	1600 hp (x2)
Weight Loaded	16,300 lb.s	17,500 lb.s

Pilot's Notes:

The P-38 Lightning was the first American fighter to be designed as a long-range, high-altitude interceptor. However, due to technical problems, it failed to successfully fill its intended role in the European theater, and was quickly replaced by the P-51 Mustang. The Lightning did perform well when used as a tactical fighter-bomber, thanks to its long range, heavy armament, and its ability to carry a heavy bomb load. Despite its size, the P-38 could maneuver with the best of the German fighters at low altitude, and was often referred to as the "Twin-Tailed Devil" by the German pilots.

The Lightning has also proved itself competent for long-range escort and reconnaissance missions. In addition to being an effective fighter at low and medium altitudes, it also provides good ground support. A P-38 is difficult to destroy—if one engine is damaged, the other is more than capable of carrying it.

This fighter (like most) is most vulnerable when alone, so a wise pilot avoids one-on-one dogfights. If you're smart, you'll work with a wing-man, using a hit-and-run strategy. If an enemy gets on your tail, try to exploit the P-38's maneuverability—ditch the bogey with a series of sharp turns, then head for the clouds. Due to severe tail buffeting, the Lightning is not particularly good in a dive.

REPUBLIC P-47 THUNDERBOLT



- Fixed Weapons: 8 wing-mounted .50-caliber Browning machine guns
- Ammunition: 300 rd/gun
- Firing Rate: 750 rd/min
- Span: 40' 9"
- Length: 36' 1"
- Height: 14' 2"
- Engine: Pratt & Whitney Double Wasp R-2800

	Model C	Model D
Max. Speed	419 mph	436 mph
Cruise Speed	210–275 mph	210–275 mph
Ceiling	41,000 feet	40,000 feet
Combat Radius	275 miles	315 miles
Fuel Capacity	305 gallons	370 gallons
Wing Area	300 sq. ft.	300 sq. ft.
Horsepower	2300 hp	2600 hp
Weight Loaded	13,500 lb.s	14,500 lb.s

Pilot's Notes:

Often referred to as the "Jug" by its pilots, the P-47 was designed around the new Pratt & Whitney Double Wasp 2,000 hp radial engine—the most powerful available at the time. The Thunderbolt was also equipped with a turbo-supercharger, which allowed full power even at an altitude of 30,000 feet and let the P-47 outperform any German fighter at high altitude. This plane also served well as a low-altitude fighter-bomber due to its heavy firepower and its ability to sustain heavy damage.

The Achilles' heel of the P-47 is its poor rate of climb. This is countered by a first-class diving ability, which you can sometimes exploit to regain height rapidly. Once you lose momentum from the dive, your best bet is not a steep and straight ascent; instead, climb in gentle turns to reach your desired altitude.

In the Thunderbolt, your strongest individual defense is generally to initiate the attack. Use the plane's superior speed and the quickness of its dive to make a pass at an enemy, then drop sharply down and away. When threatened in combat, if all else fails and you just can't shake your attacker, take comfort in the Thunderbolt's reputation for surviving a heavy beating.

NORTH AMERICAN P-51 MUSTANG



- Fixed Weapons: [B] 4 wing-mounted .50-caliber Browning machine guns
[D] 6 wing-mounted .50-caliber Browning machine guns
- Ammunition: [B] 350 rd/gun
[D] 400 rd/gun 2 inner pairs 270 rd/gun outer pair
- Firing Rate: 750 rd/min
- Span: 37' 0"
- Length: 32' 3"
- Height: 13' 8"
- Engine: [B] Packard Rolls-Royce Merlin V-1650-3
(Allison V-1710 early)
[D] Packard Rolls-Royce Merlin V-1650-7

	Model B	Model D
Max. Speed	439 mph	437 mph
Cruise Speed	210–320 mph	210–320 mph
Ceiling	42,000 feet	41,900 feet
Combat Radius	450 miles	450 miles
(with drop tank)	(750 miles)	(750 miles)
Fuel Capacity	269 gallons	269 gallons
Wing Area	233 sq. ft.	233 sq. ft.
Horsepower	1600 hp	1720 hp
Weight Loaded	9690 lb.s	10,100 lb.s

Pilot's Notes:

Considered by many to be the best fighter of the war, the Mustang originated with an Allison engine as an under-powered, low-altitude attack aircraft meant for export. However, when mated with the Rolls-Royce Merlin 61 engine, the P-51 was transformed from a modest low-level fighter-bomber into an excellent high-altitude escort fighter. With a pair of drop tanks, the Mustang could escort bombers from England to anywhere in Germany. Entering service in early 1944, this aircraft was to be a vital lifeline for American bomber crews throughout the remainder of the war.

With its vast range, great maneuverability, and a speed no other fighter can beat, the P-51 is the shining star of the USAAF. In the European theater, this fighter has more enemy kills than any other plane. This fighter will be breaking records long after the war is over. The Merlin engine gives you the power for quick, steep climbs, and the Mustang has the firepower to take care of any situation. It's both accurate and stable in the dive.

The biggest shortcoming of the craft is the guns; in the B model, they can jam during tight turns, when swinging ammunition belts cause the gun breech to block. The P-51 is also unusually vulnerable to enemy ground fire, due to an easily punctured cooling system.

ROYAL AIR FORCE

On the eve of the war, British aircraft designs were more traditional and less well developed than those of the German *Luftwaffe*. Though the RAF had designed and produced many new models of aircraft in the years since the First World War—including the Spitfire and Hurricane—they had continued to lay stock in biplanes until well into the 1930s. Though engines had become increasingly more powerful and aircraft more maneuverable, the British planes were little changed in other essentials. Whether for lack of budget or foresight or both, the RAF wholly neglected the issue of armament and instead persisted in using the same planes for both offensive and defensive purposes.

Once the war began, the British soon realized their mistake. The RAF determined that it needed a long-range plane to fly coastal patrols and minimize the threat from German U-boats. None of the available aircraft, British or American, could do the job effectively, so the RAF commissioned the design of a new plane, one specialized for the task. For the Allies, this was the beginning of an age of specialization in warplanes.

In addition to soliciting an entirely new line of planes, the British also upgraded older designs like the Spitfire and Hurricane, both of which had been flying for years. Using aerodynamic innovations, more powerful engines, and improved armament, the RAF transformed its stock of warplanes, tailoring them to suit a variety of combat conditions. Combined with a well-coordinated system of radar and a rigorous training regime, this helped the British to defend their country against the tide of German aircraft flooding to their shores. The RAF triumph in the Battle of Britain led to the first widespread acceptance that air power would be one of the keys to winning the entire war.

HAWKER HURRICANE

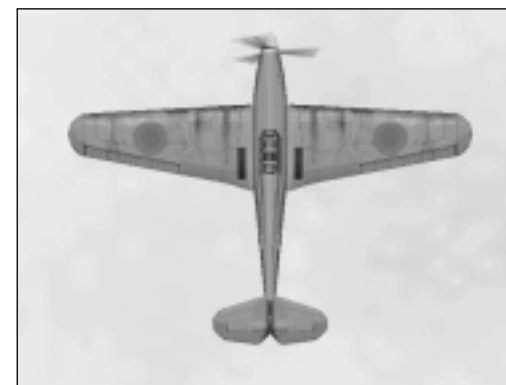

Fixed Weapons: 8 wing-mounted .303-caliber
Browning Mk2 machine guns
Ammunition: 334 rd/gun
Firing Rate: 1200 rd/min
Span: 49' 0"
Length: 31' 5"
Height: 13' 2"
Engine: Rolls-Royce Merlin III

Max. Speed	316 mph
Cruise Speed	242 mph
Ceiling	33,200 ft
Combat Radius	140 miles
Fuel Capacity	110 gallons
Wing Area	258 sq. ft.
Horsepower	1030 hp
Weight Loaded	6600 lb.s

Pilot's Notes:

The Hurricane entered service in 1937, and was the first monoplane fighter used by the Royal Air Force. It was also the first to be armed with 8 machine-guns, and the first to exceed 300 mph in level flight. It is best remembered for its actions in the Battle of Britain, during which it claimed more enemy aircraft than any other fighter involved. Although it was outclassed by most of its opponents in a straight dogfight, it remained in RAF service in various roles throughout the war.

The Hurricane is a workhorse—simple and tough, with a fixed-pitch prop and a sturdy, old-fashioned, canvas, metal, and wood construction. The design also incorporates many practical advances, such as a retractable undercarriage, enclosed cockpit, and a plate of armor behind the pilot's seat. The craft is steady; some would argue that it's a better firing platform than even the Spitfire. Cockpit visibility is also far superior than in many other aircraft.

The Hurricane handles well and is remarkably maneuverable, but it is hampered by its utter lack of speed and its sluggish acceleration, even in level flight. That's a pretty big drawback, considering that speed and acceleration can mean the difference between life and death. While entirely unsuited to ground support, the Hurricane is otherwise quite adaptable, serving in all the other possible roles for a single-seat fighter.

HAWKER TEMPEST V

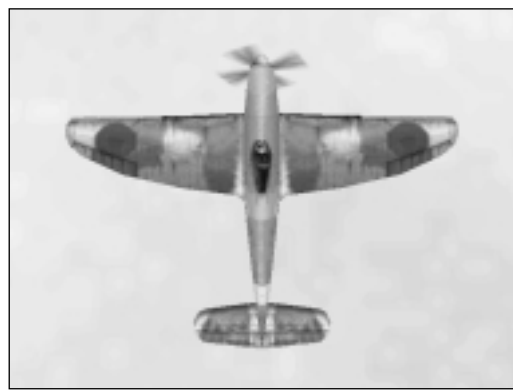
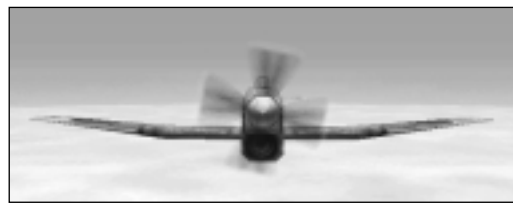

- Fixed Weapons: 4 wing-mounted 20 mm Hispano cannon
- Ammunition: 150 rd/gun (inner pair)
140 rd/gun (outer pair)
- Firing Rate: 600 rd/min
- Span: 41' 0"
- Length: 33' 8"
- Height: 16' 1"
- Engine: Napier Sabre IIA

Max. Speed	427 mph
Cruise Speed	310 mph
Ceiling	36,000 feet
Combat Radius	245 miles
Fuel Capacity	162 gallons
Wing Area	302 sq. ft.
Horsepower	2420 hp
Weight Loaded	11,500 lb.s

Pilot's Notes:

The Tempest was developed from the Typhoon, using an improved engine and a redesigned wing. Fast and maneuverable, the Tempest has proven to be an exceptional interceptor, a role in which it was widely used in the pursuit of the V-1 flying bombs and the Me262 jet aircraft. Armed with four 20mm cannons, it also served as an excellent fighter-bomber.

HAWKER TYPHOON Mk IB

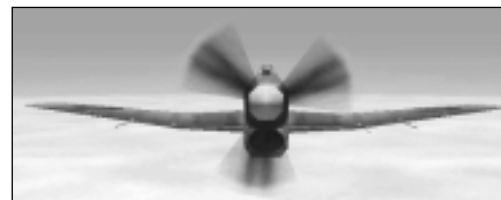

- Fixed Weapons: 4 wing-mounted 20 mm Hispano cannon
- Ammunition: 150 rd/gun (inner pair)
140 rd/gun (outer pair)
- Firing Rate: 600 rd/min
- Span: 41' 7"
- Length: 31' 11"
- Height: 14' 10"
- Engine: Napier Sabre IIA

Max. Speed	412 mph
Cruise Speed	300 mph
Ceiling	34,000 feet
Combat Radius	200 miles
Fuel Capacity	154 gallons
Wing Area	278 sq. ft.
Horsepower	2200 hp
Weight Loaded	11,780 lb.s

Pilot's Notes:

The Typhoon was designed around the Napier Sabre 2,000 hp engine, and this aircraft was meant to be an interceptor. Plagued with technical problems and structural weakness at high speed, "Tiffie" failed to fulfill this intended role. However, when used instead as a fighter-bomber, the Typhoon quickly proved to be formidable at low altitude. Armed with rockets and four 20mm cannon, it is considered one of the best fighter-bomber aircraft of the war.

A heavy plane, the Typhoon is accomplished at low altitude combat and interception missions, but does not fare as well in high speed, high altitude situations. With an experienced fighter pilot at the controls, the Typhoon can hold its own in direct combat with most other fighters.

SUPERMARINE SPITFIRE

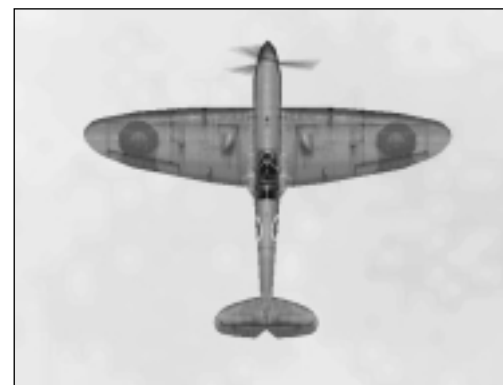

- Fixed Weapons: [la] 8 wing-mounted .303-caliber Browning Mk2 machine guns
- [Others] 4 wing-mounted (outer) .303-caliber Browning Mk2 machine guns 2 wing-mounted (inner) 20 mm Hispano cannon
- Ammunition: 350 rd/gun (mg)
120 rd/gun (cannon)
- Firing Rate: 1200 rd/min (mg)
600 rd/min (cannon)
- Span: 36' 10"



	[1a]	[IX]	[XIVc]
Length:	29' 11"	30' 6"	32' 8"
Height:	11' 5"	12' 7"	12' 8"
Engine:	Rolls-Royce Merlin II or III	Merlin 63	Griffon 65

	Model IA	Model IXC	Model XIVE
Max. Speed	355 mph	408 mph	448 mph
Cruise Speed	270 mph	325 mph	362 mph
Ceiling	34,000 feet	44,000 feet	44,500 feet
Combat Radius	190 miles	145 miles	150 miles
Fuel Capacity	102 gallons	102 gallons	138 gallons
Wing Area	242 sq. ft.	242 sq. ft.	242 sq. ft.
Horsepower	1030 hp	1565 hp	2050 hp
Weight Loaded	5784 lb.s	7500 lb.s	8500 lb.s

Pilot's Notes:

The Spitfire, most often remembered for its role in the Battle of Britain, entered the British service during the early days of the war. With its elegant line and remarkable performance, this fighter became the symbol of the nation's defense. It has superb maneuverability, excellent handling qualities, and has been described by pilots who flew it as, "aeroplane *par excellence*," and the "aeroplane of one's dream." The Spitfire was originally designed as a lightweight, short-range, defensive interceptor, and it has remained the RAF's main front-line fighter throughout the war.

In the hands of a competent airman, the Spitfire is a match for the German-engineered Me 109, surpassing it in all but dive and initial climb. Later models, including the IX and XIV, can hold their own against an Fw 190. Rely on your exceptional turning capability against these high-performance German machines, since they can outrun you in straight flight.

There's a good chance that Me 110s and other enemy craft will try a defensive circling pattern against the Spitfire. It's tricky to crack this defense, but consider circling in the opposite direction—you might manage to shoot a couple of them down, and at the very least you'll disrupt the formation. When they scatter, they're easier marks.

LUFTWAFFE

From the earliest days of combat flight, Germany has always been a leader in military airplane technology, a master in design and innovation of both engines and aircraft. During the first half of the century, the entire country was consumed with a passion for flight. State-funded flying and gliding clubs flourished and provided a fertile training ground for many a future pilot. Small wonder that Germany entered World War II with a decided edge in the arena of aerial combat.

Yet in many ways, their superiority was surprising; in the wake of the Treaty of Versailles, ending the First World War, German innovation was so respected (and feared) that virtually all military aviation was banned, as was aircraft construction of any kind. Several years later, though, the country received permission once again to design and build civilian planes, and non-military aircraft production mushroomed.

Scant evidence exists that the Germans built actual warplanes during the 1920s, but they did marshal the personnel and facilities that would one day permit them to do just that. They also devised civilian models which could later be converted with few complications into military aircraft. When, in 1935, Germany announced the formation of a new Luftwaffe (air force) and again began full-scale production of warplanes, they had top-of-the-line technology. They quickly developed beacons and radio stations to aid night flights, and they tested many of their fledgling aircraft and combat strategies in the Spanish Civil War. Entering World War II, Germany was in a very powerful position indeed.

FOCKE WULF Fw190



- Fixed Weapons: [A8 and D9] 2 cowl-mounted
13 mm MG131 cannon
[A8 and D9] 2 wing-mounted (inner) 20 mm
Mauser MG151 cannon
[A8 Only] 2 wing-mounted (outer) 20 mm Mauser
MG151 cannon
- Ammunition: 475 rd/gun (13 mm)
250 rd/gun (20 mm inner)
140 rd/gun (20 mm outer)

- Firing Rate: 900 rd/min (13 mm)
800 rd/min (20 mm inner)
400 rd/min (20 mm outer)
- Span: [A8] 10.5 m (34' 5")
[D9] 10.5 m (34' 5")
- Length: [A8] 8.84 m (29' 0")
[D9] 10.24 m (33' 5")
- Height: [A8] 3.96 m (13' 0")
[D9] 3.35 m (11' 0")
- Engine: [A8] BMW 801D
[D9] Jumo 213A

	Model A8	Model D9
Max. Speed	654 km/h (408 mph)	685 km/h (426 mph)
Cruise Speed	480 km/h (298 mph)	518 km/h (321 mph)
Ceiling	11,400 m (37,403 feet)	12,000 m (39,372 feet)
Combat Radius	266 km (165 miles)	282 km (175 miles)
Fuel Capacity	524 liters (170 gallons)	524 liters (138 gallons)
Wing Area	18.3 sq. meters (196.98 sq. ft.)	18.3 sq. meters (196.98 sq. ft.)
Max. Horsepower	1770 hp	1776 hp
Weight Loaded	4415 kg (9750 lb.s)	4293 kg (9480 lb.s)

Pilot's Notes:

The Focke-Wulf Fw190, designed by Kurt Tank, is considered Germany's best fighter of the war. When the first version entered service in 1941, it showed marked superiority to its opponents in almost every aspect—the Fw190 could outrun, outturn, and outclimb anything it encountered. However, the later models (including the A8) were primarily intended for bomber intercepts, so they carried more firepower and armor, but were therefore considerably heavier and less maneuverable. Heavily armed with four 20mm cannons and two machine-guns, the Fw190 was Allied bombers' most dreaded enemy.

The Fw190 is a joy to fly. You have excellent visibility from the cockpit, an unequalled rate of roll, and take-offs and landings are a breeze. In flight, the craft reacts quickly to the slightest command. It can both climb and dive with ease. The improved turns of the D models, coupled with an impressive armament, compact shape, and superior handling, mean that this plane is more than a match for the best enemy aircraft. It is an excellent fighter at medium altitudes, and it also has a respectable record as a fighter-bomber.

Against most American heavy bombers, use a strategy of frontal assaults. Fly high and fast to gain position ahead and above, then turn and dive toward the approaching targets, leveling out at the last moment. If you time it right, you should have up to fifteen seconds to fire away before diving out of shrapnel range. Defensively, if you're attacked in a turn, you can use your superior rate of roll to flick over into a dive. Only the best Spitfire pilot will be able to stick with you.

MESSERSCHMITT Bf109 (Me109)



- Fixed Weapons:
- [E4] 2 wing-mounted 20 mm Mauser MG151 cannon
2 cowling-mounted 7.92 mm Solothurn machine guns
 - [G6] 1 engine-mounted 20 mm Mauser MG151 cannon
2 cowling-mounted 13 mm MG131 cannon
 - [K4] 1 engine-mounted 30 mm Mk108 cannon
2 cowling-mounted 13 mm MG131 cannon



Ammunition: [E4] 60 rd/gun (cannon)
 1000 rd/gun (mg)
 [G6] 150 rd (20 mm)
 300 rd/gun (13 mm)
 [K4] 60 rd (30 mm)
 300 rd/gun (13 mm)

Firing Rate: 1100 rd/min (mg)
 900 rd/min (13 mm)
 400 rd/min (20 mm)
 500 rd/min (30 mm)

Span: [E4] 9.9 m (32' 4")
 [G6, K4] 9.92 m (32' 7")

Length: [E4] 8.8 m (28' 4")
 [G6, K4] 9.05 m (29' 8")

Height: 3.4 m (11' 2")

Engine: Daimler-Benz DB 601N

	Models E4	Model G6	Model K4
Max. Speed	570 km/h (354 mph)	620 km/h (385 mph)	727 km/h (450 mph)
Cruise Speed	483 km/h (300 mph)	520 km/h (320 mph)	590 km/h (366 mph)
Ceiling	11,000 m (36,100 ft)	11,750 m (38,550 feet)	12,500 m (41,000 feet)
Combat Radius	200 km (125 miles)	240 km (150 miles)	210 km (130 miles)
Fuel Capacity	400 liters (106 gallons)	400 liters (106 gallons)	400 liters (106 gallons)
Wing Area	16.17 sq. meters (174 sq. ft.)	16.05 sq. meters (172.75 sq. ft.)	16.05 sq. meters (172.75 sq. ft.)
Max. Horsepower	1,100 hp	1475 hp	1550 hp
Weight Loaded	2500 kg (5520 lb.s)	3148 kg (6950 lb.s)	3370 kg (7440 lb.s)

Pilot's Notes:

The Messerschmitt Bf109, which served as the Luftwaffe's standard single-seat fighter from 1936 until the end of the war, was the one of the greatest combat aircraft of its era. First appearing in 1935, it was the forerunner of all the modern fighters, completely outclassing all its early opponents. The Bf109 was not an easy plane to fly—it had weak landing gear and high wing loading—but its enjoyed a great capacity for progressive development. Later models sported increases in engine power, firepower, and armor. Though they were considerably heavier and less maneuverable than the earlier models, they were still very capable fighter planes.

This short-range, front-line fighter is quicker, lighter, and more stable than many of its contemporaries. Its structure is incredibly tough, and you should be able to roll and recover with relative ease, but it's no mean feat to fly this beast. From take-off to landing, the pilot must fight for control. The aircraft pulls hard to the right and requires a delicate balance between elevators, rudder, and throttle on take-off. Complicating matters, although cockpit visibility is generally good, a high ground angle limits the field of view while taxiing. Landings prove equally difficult. The 109 tolerates few last-minute corrections and is prone to crashes when the approach speed falls too low.

A favorite strategy of many Bf109 pilots is the negative-g roll, which leaves Spitfires and Hurricanes shooting at air. The 109 is vulnerable to deflection attacks—the armor is located a full 50 inches behind the pilot's seat—and to fire from below, due to the location of coolant reservoirs. When overmatched, the craft's speed and durability allow for a hasty exit.

MESSERSCHMITT Me110 (DESTROYER)

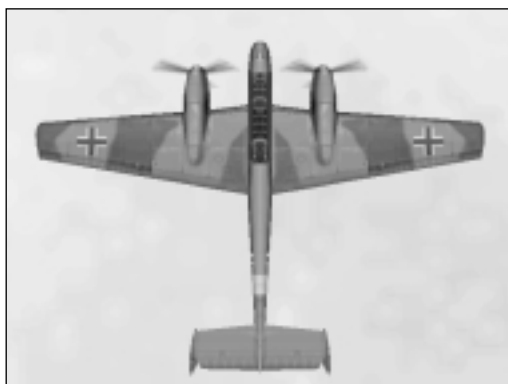

- Fixed Weapons: [C] 2 nose-mounted 20 mm Mauser MG151 cannon
 4 nose-mounted 7.92 mm Soluthurn machine guns
 1 rear-mounted 7.92 mm Soluthurn machine gun
 [G] 2 nose-mounted 30 mm Mk108 cannon
 2 nose-mounted 20 mm Mauser MG151cannon
 2 rear-mounted 7.92 mm Soluthurn machine guns
- Ammunition: [C] 180 rd/gun (cannon)
 1000 rd/gun (forward mg)
 750 rd (rear mg)
 [G] 135 rd/gun (30 mm)
 325 rd/gun (20 mm)
 800 rd/gun (rear mg)

- Firing Rate: 1100 rd/min (mg)
 400 rd/min (20 mm)
 500 rd/min (30 mm)
 Span: 16.2 m (53' 5")
 Length: [C] 12.1 m (39' 8")
 [G] 12.1 m (39' 9")
 Height: 3.5 m (11' 6")
 Engine: Daimler-Benz DB 601A-1

	Model C	Model G
Max. Speed	560 km/h (349 mph)	550 km/h (342 mph)
Cruise Speed	420–480 km/h (260–300 mph)	420–480 km/h (260–300 mph)
Ceiling	10,000 m (32,810 feet)	11,065 m (36,300 feet)
Combat Radius	290 km (180 miles)	290 km (180 miles)
Fuel Capacity	1270 liters (336 gallons)	1270 liters (336 gallons)
Wing Area	38.5 sq. meters (413 sq. ft.)	38.5 sq. meters (413 sq. ft.)
Max. Horsepower	1100 hp (x 2)	1475 hp (x2)
Weight Loaded	6740 kg (14,884 lb.s)	6988 kg (15,430 lb.s)

Pilot's Notes:

Messerschmitt's Bf110 *Zerstorer* (destroyer) was designed as a strategic long-range fighter—a heavy fighter capable of escorting bombers to and from their targets. However, it was soon found to be ineffective at its intended role; it was too heavy and not maneuverable enough to compete with the single-engine fighters in combat. The Bf110 came into its own as a *Pulk-Zerstorer* (formation destroyer), employed against the large American day-bomber formations.

The Me 110 has armor only against the head-on attack. Its heavy armaments are all trained ahead (beware a fearsome barrage of bullets when approaching from in front), but the plane lacks any effective rear guns and is badly exposed to fire from behind the pilot. Impact at close range often causes the *Zerstorer* to disintegrate, owing to its light construction. The craft has trouble competing with smaller fighters, and the pilot can't always coax out of it the necessary speed or turns to beat a hasty retreat.

MESSERSCHMITT Me262A



- Fixed Weapons: 2 fuselage-mounted 30 mm Mk 108 cannon (above nose)
2 fuselage-mounted 30 mm Mk 108 cannon (below nose)
- Ammunition: 100 rd/gun (above)
80 rd/gun (below)
- Firing Rate: 500 rd/min
- Span: 12.5 m (41' 0")
- Length: 10.605 m (34' 9")
- Height: 3.83 m (12' 7")
- Engine: 2 Junkers Jumo 109-004B-4 turbojets

Max. Speed	868 km/h (540 mph)
Cruise Speed	670 km/h (416 mph)
Ceiling	11,448 m (37,560 feet)
Combat Radius	241 km (150 miles)
Fuel Capacity	1670 liters (440 gallons)
Wing Area	21.7 sq. meters (233.3 sq. ft)
Thrust	1,980 lb.s/engine

Weight Loaded 6385 kg (14,100 lb.s)

Pilot's Notes:

The Messerschmitt Me262 was the world's first truly effective jet fighter to reach operational status. This aircraft enjoyed a speed advantage of more than 100 mph over the fastest prop-driven plane, which allowed them to sail past escort fighters and attack bombers with impunity. The main battery of four 30mm cannons was devastating to any bombers caught in its sights. However, the Me262 is slow to accelerate and not very maneuverable, and Allied pilots soon learned to attack them when they were most vulnerable—during take-off and landing.

GLOSSARY OF TERMS AND ACRONYMS

Absolute Altitude	Height of the plane above the surface of the ground, as opposed to the height above sea level, which is “true altitude.”
Acceleration	Any change in velocity, whether positive or negative. Generally used to mean an increase in velocity, with the related negative “deceleration.”
Ailerons	The aerodynamic control surfaces, usually located in the wing, that are used to produce roll.
Air Strike	An offensive maneuver in which aircraft fly to and attack a specific target.
Airfoil	Any surface on an aircraft the major function of which is interaction with the air to produce a specific effect.
Airspeed	The plane’s velocity with reference to the air through which it is moving, not the surface of the Earth.
Airspeed Indicator	Cockpit device designed to display to current airspeed of the plane.
Altimeter	A device that measures altitude.
Altitude	Distance above the surface of the Earth. Altitude may be measured relative to the actual ground surface—“absolute altitude”—or as a function of air pressure, relative to sea level—“true altitude.”
Angle of Attack	The difference, measured in degrees, between the pitch of the plane and level flight.
Artificial Horizon	A cockpit device much like a gyroscope that displays the deflection of the aircraft from level flight.
Attitude	The deflection of the aircraft from level flight.
Attitude Indicator	See Artificial Horizon.
Autopilot	A device for controlling the flight of an aircraft without input from the pilot.
Bank	Leaning, and therefore turning, of an aircraft to one side due to the position of the ailerons. The pilot causes this by pressing sideways on the stick.
Bearing	Horizontal direction to or from any point, measured clockwise in degrees from North.
Bernoulli’s Equation	A mathematical description of the physical effect that causes lift to be generated by airfoils of a certain shapes. Roughly, the idea is that as air velocity increases, the pressure of that air decreases, and vice versa.

Blackout	Loss of consciousness due to a lack of oxygenating blood flow to the brain; in aircraft this is usually caused by excessive centripetal acceleration.
Brakes, Dive	Airfoils used in dive bombers to allow these planes to dive more steeply without gaining excessive airspeed.
Brakes, Wheel	Devices used to slow an aircraft on the ground by retarding the rotation of the wheels.
Cannon	Weapons mounted on an aircraft that are too large in caliber or bore size to be considered machine guns. A cannon fires shells (often explosive) rather than bullets.
Ceiling	The greatest altitude a certain aircraft can attain. The related term “service ceiling” is the greatest altitude at which a given aircraft will function controllably. Ceiling is primarily a function of available thrust and the lift potential of the major airfoil.
Centrifugal Force	A non-existent force, believed by some to be the name for the outward acceleration caused by inertia when turning.
Centripetal Acceleration	The real name for acceleration due to turning; this acceleration is directed inward, toward the center of the turn. Inertial effects cause the “g’s” experienced by pilots.
CH	The standard aviation abbreviation for “compass heading.”
Climb	Aeronautic term for an increase in altitude—i.e. going up.
Cockpit	Where the pilot sits; this area includes all of the devices and instruments necessary for controlling the aircraft.
Compass	A magnetic device that indicates the direction of the aircraft’s flight, measured as a function of magnetic North.
Compass Heading	The magnetic heading, as different from the bearing.
Compound	A situation in which a pilot faces more than one emergency condition.
Emergency Coordinated Turn	A turn (bank) during which the rudder is used with the ailerons to prevent adverse yaw.
Cowling	The structure that covers and streamlines the plane’s engine and channels cooling air across it.
Deceleration	Negative change in velocity; slowing down.
Ditching	A forced landing in the water.



Dive Any nose-down, substantial loss of altitude.

Dogfight Combat between aircraft in the air.

Dorsal Located on the “top” of the aircraft, but behind the pilot and cockpit.

Drag The force that opposes the movement of the plane through the air, sometimes called air or wind resistance.

Drift Deflection of the plane from its intended course due to the wind.

Dud Any explosive device that does not explode when it is supposed to.

Echelon A standard flight formation in which each plane flies behind and to the side of the one in front of it, forming a diagonal or “stair-step” line.

Element A pair of planes consisting of a leader and his wingman. The leader (the senior flyer and better marksman) attacks the enemy, while his wingman guards against assaults from behind. The wingman flies slightly behind and to the left or right of the leader, on the same side as the sun.

Engine, Radial Any engine with the cylinders arranged in a circular fashion, usually around the lengthwise axis of the aircraft.

Engine, Piston Any engine with the cylinders arranged in a straight-line or “V” fashion, as in most automobiles.

Engine Temperature Gauge The cockpit instrument which displays the operating temperature of the aircraft’s engine.

Escort A defensive flight pattern in which certain planes, normally fighters, fly ahead of (but near) another plane or group of planes in order to detect and defend against intercepting aircraft.

External Tank A fuel tank carried on the outside of the aircraft, usually droppable in flight.

Final Approach A flight path that is lined up with the runway, in preparation for landing.

Finger Four A flight formation made up of two elements (or *rotte*). Viewed from above, the planes are spread like the four fingers on an outstretched hand.

Flak Slang term for anti-aircraft fire (AAA) or other non-missile Surface-to-Air munitions.

Flight Term for a pair of elements flying together in formation.

Flight Crew The personnel who prepare the aircraft for take-off. Their tasks include fueling the planes, performing service checks, and loading munitions.

Fuel Gauge The cockpit instrument that measures the amount of fuel remaining in the plane’s tanks.

G Force Acceleration due to gravity. In aeronautics, the term is also used for the forces on the bodies of the crew that are caused by the inertial effects of high-acceleration turns.

Glide Flight without power or without thrust.

Go-around An aborted landing attempt, wherein the pilot has to “go around” and begin a new approach.

Greyout A partial blackout or semi-consciousness.

Ground Effect An apparent gain in lift when the aircraft is flying at or below one wingspan’s height above the surface. This is caused by the reduction in drag due to the diffusion of the plane’s downwash against the surface.

Ground Loop A landing in which a wingtip touches ground, causing the aircraft to flip and crash.

Ground Speed Velocity relative to the surface of the Earth; true airspeed corrected for wind effects.

Gunner, Belly Term widely used by allied personnel to refer to a ventral gunner.

Gunner, Dorsal Same as the rear gunner.

Gunner, Rear That crewman who mans the dorsal weapon(s).

Gunner, Tail Term widely used by allied personnel to refer to a rear gunner.

Gunner, Ventral That crewman who mans the ventral (belly) weapon(s).

Gunner, Waist That crewman who mans the side-facing weapon(s) located near the middle of a plane.

Heading Essentially the same thing as bearing.

IAS The standard aviation abbreviation for “indicated airspeed.”

Immelmann A maneuver for gaining altitude and changing direction.

Indicated Airspeed The airspeed displayed by the airspeed indicator.

Instrumentation All the stuff in the cockpit that tells the pilot what’s going on in and around the aircraft; the gauges and dials.

Knot	One nautical mile per hour, abbreviated "kt." A nautical mile is approximately one minute of latitude, 1.15 statute miles, or 2,000 yards.
Land Flow Turbulence	A turbulent airflow caused at low altitudes by winds passing around obstacles (hills, buildings, coyotes, tanks, etc.).
Latitude	Distance north or south of the equator, measured in degrees, minutes, and seconds.
Load-out	The ordnance carried on an aircraft, not including ammunition for fixed guns.
Longitude	Distance east or west of the Greenwich Meridian, measured in degrees, minutes, and seconds.
Missed Approach	See Go-around.
Negative g's	G forces acting in the direction opposite that of gravity; these are the g's that make the pilot feel "lifted" and can cause redouts.
Oil Pressure Gauge	The cockpit instrument that displays the pressure of the oil running through the aircraft engine; a good indicator of the amount of damage the engine has taken.
ONC	The standard aviation abbreviation for "operational navigation chart."
Operational Navigation Chart	The cockpit map.
Ops	Standard military shorthand for "operations."
Pan	Motion of the camera from left to right or right to left around a center; roughly equivalent to the aircraft motion "yaw."
Payload	Drop weapons carried on the aircraft; same as load-out.
Pilot	The person who is the primary controller of the aircraft.
Pitch	The angle of the aircraft's long axis in relation to level flight.
Positive g's	G forces acting in the direction of gravity; these are the g's that make the pilot feel "forced into the seat" and can cause blackouts.
Propeller	The airfoil attached to the engine, used to generate thrust.
Radar	RAdio Detection And Ranging equipment; this is not standard equipment in the aircraft of the early 1940s.
Radar Altimeter	A modern device used to gauge the absolute altitude of an aircraft using radar.

Redout	Loss of vision and possibly consciousness due to bursting blood vessels in the corneas or other parts of the eyes. This is usually caused by excess negative g's.
Roll	(1) Motion of the aircraft around its long axis, as when one wing rises and the other falls; (2) Motion of the camera around its parallel horizontal axis, roughly equivalent to the aircraft motion of the same name.
Rotte	German term for "element."
Rudder	The control surface mounted on the tail of the aircraft and used to control the yaw of the plane.
Schwarm	Word in German for a pair of <i>rotte</i> ; same as "flight."
Scissors	A two-plane maneuver in which opposing aircraft repeatedly attempt to outturn one another in order to get the first shot.
Sea Level	Zero altitude; the altitude at the surface of the ocean.
Sink Rate	Vertical speed of descent.
Skid	Sideways motion of an aircraft in flight, generally caused by over-ruddering. Unlike slip, skid does not involve the ailerons.
Slip	Motion of the aircraft that is not in line with the long axis; sideways flight. This is generally caused by intentionally over-ruddering in one direction while banking in the opposite one.
Spin	Rotation of the plane around its center of gravity during a prolonged stall, usually coincident with a pronounced loss of altitude.
Split-S	A maneuver similar to an Immelmann, but involving a loss of altitude rather than a gain.
Squadron	A group of military aircraft.
Stall	A condition in which the aircraft has lost all of its lift; this happens when the plane's angle of attack exceeds that required for maximum lift and thus gives rise to turbulent airflow around the wing.
Stick	The pilot's primary device for controlling the ailerons and elevators.
Tachometer	The cockpit instrument that displays the revolutions per minute of the engine crankshaft.
Thach Weave	A three-plane maneuver used by two cooperating planes to bring a third (enemy) plane that is behind the leader repeatedly through the line of fire of the wingman.
Throttle	The pilot's primary device for controlling the RPMs of the engine and, thus, the thrust.



Tilt	Motion of the camera up or down around a center; roughly equivalent to the aircraft motion "pitch."
Torque	The twisting effect on the plane of the rotation of the engine crankshaft and propeller.
Track	Motion of the camera from one location to another, as distinct from the motion about a center described in pan, tilt, and roll.
Transverse g's	G forces acting in a direction perpendicular to that of gravity; these are the g's that make the pilot feel "pushed to the side." Transverse g's are much more dangerous than either positive or negative g's, since they can rapidly causes organ damage.
Trim	Repositioning of the primary control surfaces to correct for tendencies of the aircraft.
True Altitude	Distance from sea level, usually calculated as a function of ambient air pressure.
V (or vee)	The standard formation for a bomber. The lead aircraft is flanked on each side by a plane flying slightly behind, thus forming a V. Any additional planes extend the legs of the V.
Velocity	Distance traveled over a period of time; speed.
Ventral	Located on the lower surface or "belly" of the aircraft, usually behind the wing.
Visibility	The distance the pilot can see from the cockpit; visual range.
Windmilling	A propeller that is in motion due to the effects of wind and airspeed, rather than impelled by the engine crankshaft, is said to be "windmilling."
Wing	The primary airfoil for generating lift.
Yaw	Movement of the aircraft about its vertical axis.
Zoom	(1) Change in the focus of a camera. Zooming in causes the camera to focus on objects that are smaller or farther away, thus limiting the horizontal scope of the focus; zooming out causes the camera to focus on closer or larger objects, thereby expanding the horizontal scope and bringing more of the scene into the view; (2) In flight, a fast, steep climb. Generally, a zoom is preceded by a dive. The dive provides the speed necessary to climb more steeply, without stalling, than would be possible using the engine's thrust alone.

CREDITS

Producer	Martin De Riso
Game Design	Tsuyoshi Kawahito
Design Support	Tim Goodlett, Warren Capps
Programming	Tsuyoshi Kawahito, Lead Programmer Rob Hafey Brandon Gamblin Chris Coon Will Gee Rob Knopf
Art	Susan Clausen Paquin, Lead Artist Dave Thompson Rob Cloutier Matt Bell, Erik Ehoff Sam Laskowski Evan Brown Mike Reis John Cameron Stacey Tranter
Music Composed by	Roland Rizzo
Audio Design & Recording	Mark Cromer Mark Reis
	Voice Talent
	Jonathan Bryce, Brandon Gamblin, Mike Dubose Dave Ellis, Mark Reis, Mark Cromer
Documentation	Anne Stone John Possidente Tim Goodlett Richard Henning Reiko Yamamoto, Layout & Design



Marketing Tom Nichols, U.S.
Adrian Turner, UK
Thomas Sewing, Germany
Kathy Sanguinetti, Public Relations

Quality Assurance Steve Purdie, Test Lead
Mark Gutknecht, Test Lead
Paul Ambrose
Tim Beggs
Matt Bittman
Ellie Crawley
Mike Davidson
Rose Kofsky
Charles Lane
Jason Lego
Brandon Martin
Rex Martin
Sal Saccheri
Rick Saffery
Jeff Smith

Localization Karen Ffinch
Sarah Collins
SDL

Special Thanks

Tom Basham, Brian Workman, Doug Jeanes, "Lad" Doctor, RAF Wing
Commander James Isles (Retired), Marisa Ong, Kathryn Lynch, and
Sammy the Wonder Beagle

© 2001 Infogrames Interactive, Inc. All Rights Reserved.

Infogrames and the Infogrames logo are the trademarks of Infogrames Entertainment S.A.

Uses Smacker Video Technology, Copyright © 1994-2001 by RAD Game Tools, Inc.

3D models in Intro, AutoPlay screen and Hangars by REM Infografica TM. RTPatch is a registered trademark of POCKET SOFT, Inc.

WINDOWS® is a registered trademark of Microsoft Corporation. PENTIUM® is a registered trademark of Intel Corporation.

All other trademarks or tradenames are the property of their respective owners. ® denotes Reg. US Patent & TM office.