



# Comparison of the Performance of the DS4500 (FAStT900) and DS4400 (FAStT700) Storage Servers

*Charles Stephan*

IBM eServer xSeries Performance Development & Analysis  
Research Triangle Park, North Carolina, USA

## Abstract

**This white paper has been updated to reflect the renaming of the FAStT family of products as of September 7, 2004. The only changes to this paper are the affected product names (e.g., FAStT becomes DS4000, FAStT700 becomes DS4400, FAStT900 becomes DS4500, FAStT EXP700 becomes DS4000 EXP700).**

This paper provides the baseline performance of the IBM® TotalStorage® DS4500 Storage Server, which employs IBM DS4000 storage technology (formerly Fibre Array Storage Technology, i.e., FAStT).

The purpose of this paper is to present the results obtained using the Iometer tool to measure the raw performance of the DS4500's RAID subsystem. The DS4500's performance is compared to that of its predecessor, the IBM TotalStorage DS4400 Storage Server.<sup>1</sup>

The paper is organized in four sections. The first section briefly describes the tool used to measure the performance of the DS4500 and DS4400, and defines the workloads used in the measurements. The second section describes the hardware and software measurement environment. The third section presents the results of the measurements and explains how the results should be interpreted. Finally, the fourth section summarizes the performance gains demonstrated by the DS4500.

Important lessons learned from this performance study are highlighted in boxes at appropriate points throughout the paper.

Questions about the information presented should be directed to the author at [stephanc@us.ibm.com](mailto:stephanc@us.ibm.com) or Charles T Stephan/Raleigh/IBM@IBMUS.

---

<sup>1</sup> The measurement results in this paper represent data that was written to disks or read from disks. The results do not represent data that was read strictly from RAID controller cache or written strictly to RAID controller cache. While both methods produce valid data, a discussion of "out-of-cache" or "to-cache" measurements does not fit within the scope of this document.

## Measurement Tool and Workloads

Iometer is a workload generator and a measurement tool originally developed by Intel Corporation. It is now maintained under an Intel® Open Source License, and it is available at <http://sourceforge.net>.

Iometer is designed to generate workloads and record measurement results for server disk and network subsystems—*not* desktop disk and network subsystems. In this context, the use of the words “server” and “desktop” is not a trivial matter. Consider the following example.

The single-threaded utility *copy* is routinely used to test server disk subsystems. The *copy* utility is a fine benchmark for a laptop or desktop machine, but not for a server. Why is it used so often for measuring server disk subsystem performance? It is probably used for two reasons. First, *copy* is easy to execute, and does not require large amounts of resources. The second reason is that the differences between server architecture and desktop architecture may not have been understood by the people implementing the benchmark.

Desktop machines are designed to manage one task at a time, and they do this very well. In fact, when *copy* is executed, a desktop machine with a single hard drive will usually perform better than a server with an array of multiple drives. The reason for the performance disparity is based on the design differences of the two machines. Servers are designed to handle multiple tasks in parallel. So, when *copy* is executed on a server, some server operating systems will bounce the *copy* process from CPU to CPU, because it is designed to keep all of the CPUs busy (Microsoft® Windows® 2003 will no longer do this). This is very costly with regard to performance. Furthermore, since *copy* is single-threaded, each I/O request must be satisfied before another I/O request can be generated. Therefore, the multiple-drive array is not being utilized efficiently, because only one drive is required to satisfy each I/O request.

One way to measure the performance of a server disk subsystem is to use Iometer. Iometer, by default, provides “workers” for each CPU in the system. This satisfies the need to keep all CPUs busy, and thus, multiple I/O requests can be issued in parallel so that all of the drives in an array can be kept busy just as it is done by a high-performance SMP server application. Iometer also provides a configurable parameter, called “outstanding I/Os,” which can be used to increase the load on a server disk subsystem. The measurement results contained in this paper were generated by increasing the number of outstanding I/Os queued at the drives up to and beyond what would be typical in a production environment.

Do not use desktop-oriented tools or single-threaded utilities, such as *copy*, to measure a server’s disk subsystem performance. Iometer is specifically designed to generate workloads on servers that utilize all of the CPUs in parallel, which ensures that I/O requests are issued in parallel to the disk subsystem.

*The measurement results in this paper were obtained using Iometer version 2003.02.15, Copyright 1996-1999 Intel Corporation. Intel does not endorse any Iometer results.*

The workloads used to yield the results in this document were the On-Line Transaction Processing workload, Streaming Reads workload, Streaming Writes workload, File Server workload, Web Server workload, Random Reads workload, and the Random Writes workload. The characteristics for each workload are described in the following sections.

## **Comparison of the Raw Performance of the DS4500 (FAStT900) and DS4400 (FAStT700) Storage Servers**

### **On-Line Transaction Processing Workload**

The On-Line Transaction Processing (OLTP) workload is designed to emulate a transactional database workload. It is defined as 100% random accesses, 67% reads, and 33% writes. This workload is measured using transfer request sizes of 4K, 8K, 16K, 32K, and 64K.

### **Streaming Reads Workload**

The Streaming Reads workload is designed to emulate a read-intensive multimedia streaming application. It is defined as 100% sequential accesses and 100% reads. This workload is measured using transfer request sizes of 512 bytes, 1K, 2K, 4K, 8K, 16K, 32K, 64K, 128K, 256K, and 512K.

### **Streaming Writes Workload**

The Streaming Writes workload is designed to emulate a write-intensive multimedia streaming application. It is defined as 100% sequential accesses and 100% writes. This workload is measured using transfer request sizes of 512 byte, 1K, 2K, 4K, 8K, 16K, 32K, 64K, 128K, 256K, and 512K.

### **File Server Workload**

The File Server workload consists of a mixture of various transfer request sizes. It is defined as 100% random accesses, 80% reads, and 20% writes. The mixture of transfer request sizes is defined as:

- 10% 512 Byte
- 5% 1K
- 5% 2K
- 60% 4K
- 2% 8K
- 4% 16K
- 4% 32K
- 10% 64K

### **Web Server Workload**

The Web Server workload is designed to emulate a Web server delivering static content. It is defined as 100% random accesses and 100% reads. This workload consists of a mixture of transfer request sizes that is defined as:

- 22% 512 Byte
- 15% 1K
- 8% 2K
- 23% 4K
- 15% 8K
- 2% 16K
- 6% 32K
- 7% 64K
- 1% 128K
- 1% 512K

## **Comparison of the Raw Performance of the DS4500 (FAStT900) and DS4400 (FAStT700) Storage Servers**

### **Random Reads Workload**

The Random Reads workload is defined as 100% random accesses and 100% reads. This workload is measured using transfer request sizes of 4K and 8K.

### **Random Writes Workload**

The Random Writes workload is defined as 100% random accesses and 100% writes. This workload is measured using transfer request sizes of 4K and 8K.

## **Measurement Environment**

The measurements were conducted using the IBM® eServer® xSeries® 345 with two Intel Pentium® 4 3.0GHz Xeon™ processors and 512MB of system memory and the IBM eServer xSeries® 235 with two Intel Pentium 4 2.4GHz Xeon processors and 1024MB of system memory. The operating system installed was Microsoft Windows 2000 Advanced Server 5.0.2195 (Build 2195) with Service Pack 4.

Both systems contained two IBM TotalStorage DS4000 FC-2-133 Host Bus Adapters using driver version 8.2.3.63.

The Fibre Channel management software used was Redundant Disk Array Controller (RDAC) version 08.41.95.02 and Storage Manager Client version 08.41.G5.01.

The Fibre Channel RAID controller software used on the DS4500 RAID controllers was Appware version 05.40.06.00, Bootware version 05.40.02.00, and NVSRAM version N1742F900R840V02. Each DS4500 RAID controller contained 1024MB of cache.

The storage backend consisted of 14 IBM TotalStorage DS4000 EXP700 Storage Expansion Enclosures with ESM firmware version 9325. The EXP700 enclosures contained 18.2GB, 15K rpm drives with firmware version B947.

# Comparison of the Raw Performance of the DS4500 (FAStT900) and DS4400 (FAStT700) Storage Servers

## Configuration Diagrams for the Measured Hardware

### Random Access Measurements Hardware Configuration Diagram

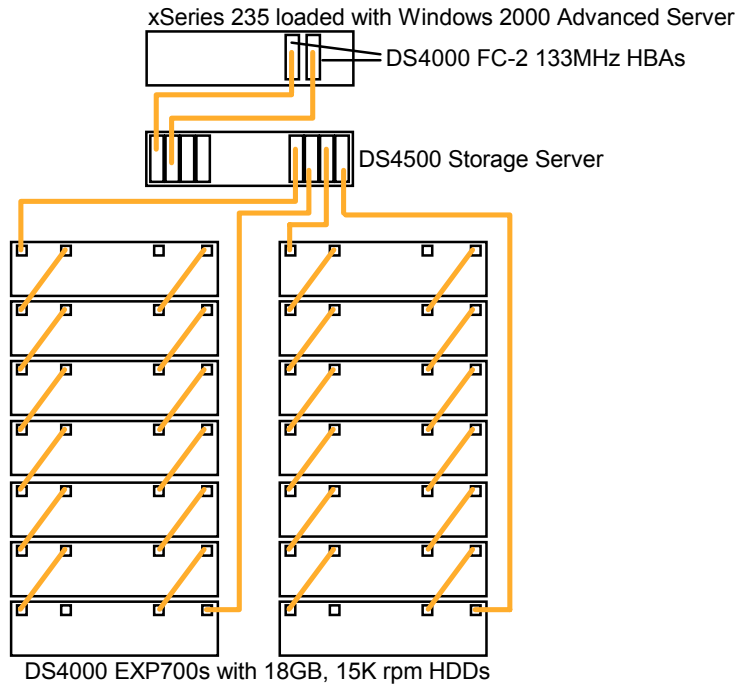

### Sequential Access Measurements Hardware Configuration Diagram

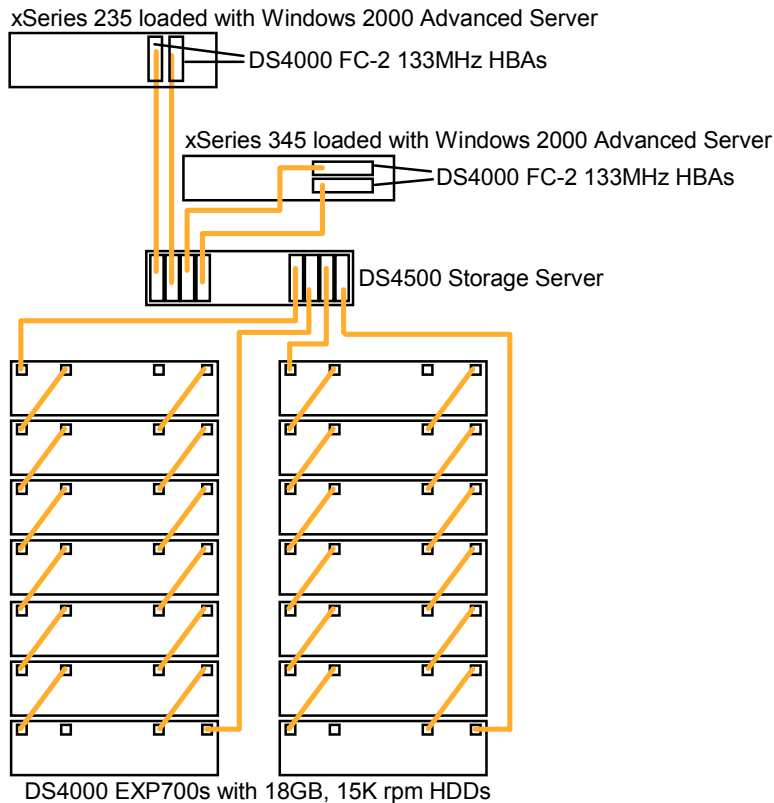

**Comparison of the Raw Performance of the DS4500 (FAStT900) and DS4400 (FAStT700)  
Storage Servers**

## Measurement Results and Analysis

*The performance information contained in this section was derived under specific operating and environmental conditions. The results obtained in your operating environments may vary significantly.*

The measurement results in this section represent the maximum sustainable performance for a configuration using dual DS4500 RAID controllers with a specified number of hard disk drives (HDDs) utilized that corresponds to an average response time of approximately 20 milliseconds (ms). The results in this section may not correspond to what is commonly referred to as the “peak” performance. Peak performance typically refers to a measurement result with the highest number of I/Os or MBps regardless of the average response time associated with that result. However, since most server applications will not wait forever for disk I/O to complete, the 20ms threshold was used because it represents a reasonable amount of time for an application to wait for completion of disk I/O before overall performance begins to decrease.

### RAID-5 OLTP Workload Results

Table 1 contains RAID-5 measurement results for the OLTP workload for various transfer request sizes. The data in Table 1 corresponds to the results achieved at an average response time of 20 ms. The drives were configured in arrays of 10, and only 8% of the total capacity of the drives was used. This is true for all of the measurements unless otherwise noted. Finally, a 64K segment was configured for the arrays and the cache block size was 4K, because this produced optimal disk subsystem throughput for these workloads. Cache mirroring was disabled.

**Table 1. DS4500 RAID-5 OLTP I/Os\***

Workload		OLTP 4K		OLTP 8K		OLTP 16K		OLTP 32K		OLTP 64K	
RAID-5		I/Os	MBps	I/Os	MBps	I/Os	MBps	I/Os	MBps	I/Os	MBps
<b>20 HDDs</b>	All Caches Disabled	3095	12	3000	23	2790	43	2185	68	1660	104
	Write Cache Enabled	3860	15	3800	29	3620	56	2620	82	1880	117
<b>60 HDDs</b>	All Caches Disabled	9280	36	8880	69	8080	126	5120	160	2780	174
	Write Cache Enabled	11,360	44	10,960	85	9885	154	5525	172	3150	196
<b>100 HDDs</b>	All Caches Disabled	15,340	60	14,320	111	9055	141	5155	161	2755	172
	Write Cache Enabled	24,340	95	15,880	124	10,315	161	5765	180	3215	200
<b>140 HDDs</b>	All Caches Disabled	20,320	79	15,025	117	9060	141	5170	161	2770	173
	Write Cache Enabled	20,500	80	16,525	129	10,340	161	5780	180	3200	200
<b>180 HDDs</b>	All Caches Disabled	18,965	74	15,040	117	9130	142	5200	162	2780	173
	Write Cache Enabled	20,540	80	16,450	128	10,345	161	5800	180	3200	200

\*Results correspond to an average response time of 20 ms.

## Comparison of the Raw Performance of the DS4500 (FAStT900) and DS4400 (FAStT700) Storage Servers

It is worth observing two things concerning Table 1. First, it can be observed that the I/Os tend to decrease from left to right across the table as the transfer request size increases. However, notice that the transfer rate (MBps) increases from left to right. Transferring larger amounts of data for each request utilizes the fiber bandwidth more efficiently.

Second, the I/Os and transfer rate tend to increase from top to bottom as more drives are utilized. Furthermore, notice that the I/Os and transfer rate tend to level off or drop slightly in the bottom half of the table. For example, following the 8K column down, it can be observed that the I/Os with 140 HDDs utilized and write cache enabled are 16,525. The I/Os with 180 HDDs utilized and write cache enabled are 16,450. This means that 16,525 I/Os is probably the maximum number of RAID-5 OLTP 8K I/Os to disk, that dual DS4500 RAID controllers can achieve.

*Do not conclude that adding more than 140 HDDs will not increase the number of 8K I/Os the DS4500 Storage Server can achieve in production environments. In production environments where the working data set spans a greater percentage of the disk capacity, a user could expect to see an increase in the number of I/Os as HDDs are added beyond 140 HDDs. However, the I/Os will be less than the results in Table 1.*

Remember, the data in Table 1 was achieved using a disk stroke of 8% and does not reflect typical storage capacity usage in a production environment. Think of the “disk stroke percentage” as the percentage of disk capacity required for a user’s working data set. The phrases “working data set” and “disk stroke percentage” are used interchangeably. As the working data set grows, so does the time for seek operations. One can expect production workloads to have longer seek times because of both capacity utilization and disk fragmentation. Table 2 contains information that can be used to approximate the performance of the DS4500 Storage Server in a RAID-5 OLTP environment assuming different working data set sizes.

**Table 2. RAID-5 OLTP Drive Stroke Percentage Multiplier**

Transfer Request Size	To approximate the RAID-5 OLTP I/Os for the following disk stroke percentages, multiply the 8% disk stroke I/Os from Table 1 by the corresponding multiplier...					
	15%	30%	45%	60%	75%	90%
RAID-5 OLTP 4K, 8K, and 16K	0.88	0.80	0.74	0.72	0.66	0.65

For example, if a user has 100 drives attached to dual DS4500 RAID controllers, and the 100 drives are dedicated to transaction processing with an average transfer request size of 8K, the performance the user could expect from a hardware perspective would greatly depend on the size of the working data set and the capacity utilization. The maximum performance the user could expect would be 14,320 I/Os according to Table 1, assuming all caches were disabled. But that performance is based on a disk stroke percentage of 8%. Assuming the user’s working data set spans approximately 45% of the capacity of the drives, a more realistic estimate of the maximum performance expected can be determined by multiplying 14,320 I/Os by 0.74 (from Table 2), which equals 10,595 I/Os.

Looking at the multipliers in Table 2 from left to right, it can be observed that the estimated performance will decrease as the disk stroke percentage increases. This is due to the mechanical positioning latencies of the HDDs as a result of seeking for random data accesses. Use Table 2 to obtain approximate performance and not precise performance. This estimation method does not consider the effect of users on performance.

## Comparison of the Raw Performance of the DS4500 (FAStT900) and DS4400 (FAStT700) Storage Servers

Hard drive performance decreases as the working data set spans more of the capacity of the drives while executing a workload characterized by a large percentage of random data accesses. This is due to the mechanical latencies of disk drives.

Hard drive performance does not decrease significantly, if at all, as the working data set spans more of the capacity of the drives while executing a workload characterized by a large percentage of sequential data accesses.

Chart 1 illustrates the performance of dual DS4500 RAID controllers and dual DS4400 RAID controllers for the RAID-5 OLTP 8K workload.

**Chart 1. DS4500 RAID-5 OLTP 8K vs. DS4400 RAID-5 OLTP 8K**

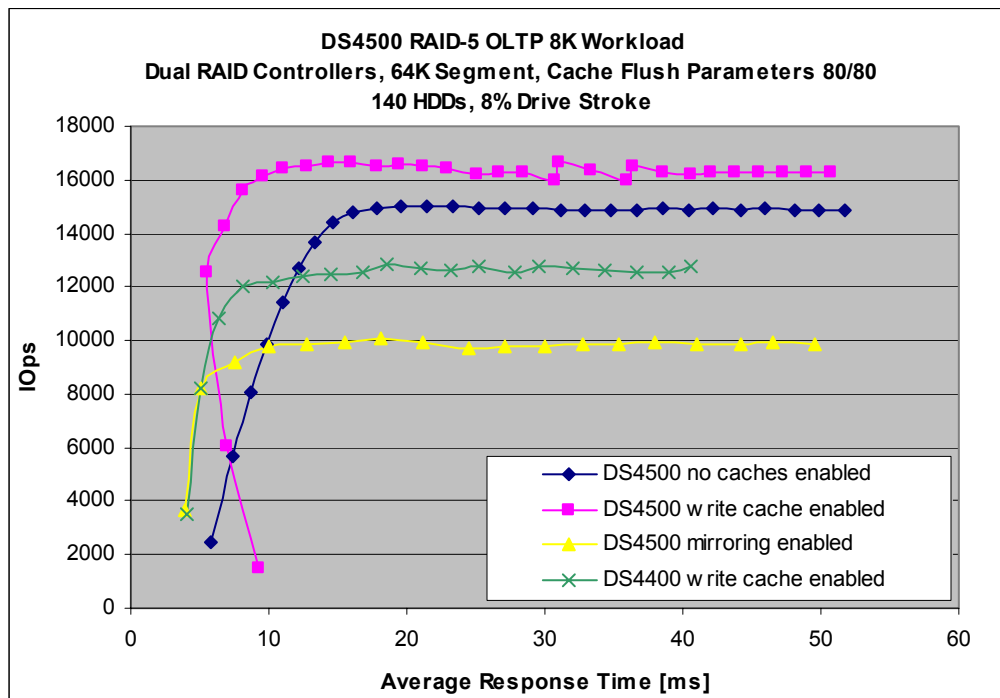

Comparing the “DS4500 write cache enabled” and “DS4400 write cache enabled” curves in Chart 1, and sampling the data that corresponds to a 20 ms average response time reveals that the DS4500 performs approximately 30% better than the DS4400 for the RAID-5 OLTP 8K workload utilizing 140 HDDs. The DS4400 was measured using the same hardware and software as the DS4500 for this comparison.

The DS4500 Storage Server performs approximately 5% to 30% better than the DS4400 Storage Server for the RAID-5 OLTP 8K workload depending on the number of HDDs utilized.



## Comparison of the Raw Performance of the DS4500 (FAStT900) and DS4400 (FAStT700) Storage Servers

### RAID-5 Streaming Reads and Streaming Writes Workload Results

Chart 2 illustrates the RAID-5 Streaming Reads performance of dual DS4500 RAID controllers versus dual DS4400 RAID controllers. The DS4400 was measured using 108 10K rpm HDDs, a 64K segment, a read-ahead multiplier of 8 (prefetch x8), and version 5.0 firmware.

**Chart 2. DS4500 RAID-5 Streaming Reads vs. DS4400 RAID-5 Streaming Reads**

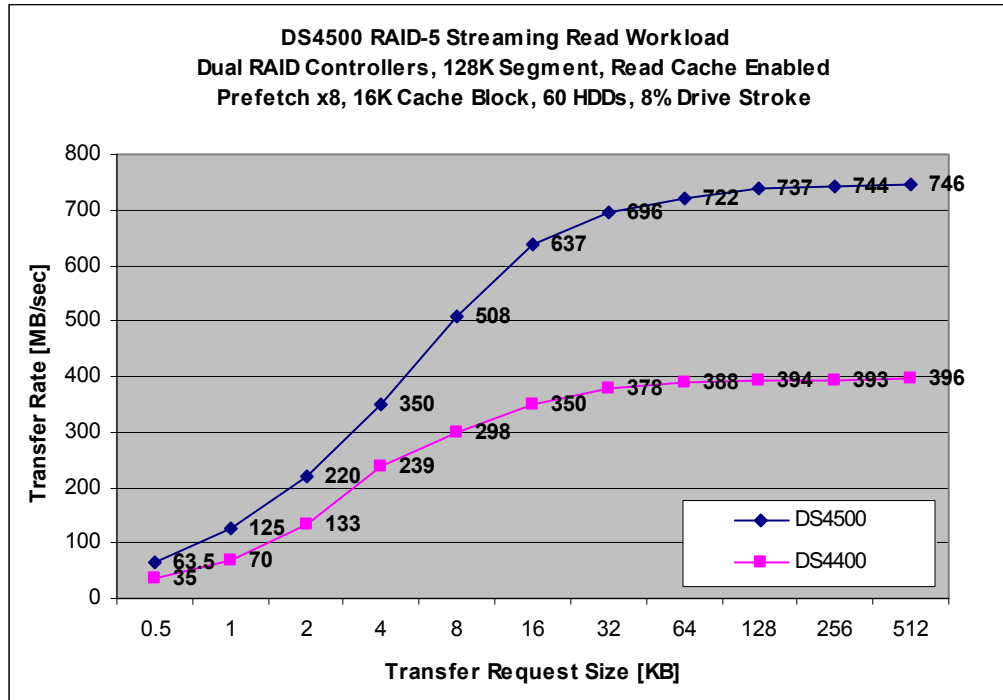

The DS4400 transfer rate for 64K transfer requests is 388MBps, and the DS4500 transfer rate for 64K transfer requests is 722MBps. After compensating for older drive technology by boosting the DS4400 transfer rate by 5%, the DS4500 performs approximately 75% better than the DS4400 for 64K transfers for the RAID-5 Streaming Reads workload. The performance difference between the 10K rpm HDDs and the 15K rpm HDDs is probably more than 5%. However, the DS4400 is not capable of achieving more than about 400MBps, so it is assumed that the controllers would bottleneck before the performance increase attributed to the 15K rpm HDDs could be realized.

The DS4500 Storage Server performs approximately 50% to 75% better than the DS4400 Storage Server for the RAID-5 Streaming Reads workload over a transfer request range of 512 bytes to 512KB utilizing 60 HDDs.

Chart 3 illustrates the RAID-5 Streaming Writes performance of dual DS4500 RAID controllers versus dual DS4400 RAID controllers. The DS4400 was measured using 58 10K rpm HDDs, a 64K segment, write cache enabled, write cache mirroring disabled, and version 5.0 firmware.

## Comparison of the Raw Performance of the DS4500 (FAStT900) and DS4400 (FAStT700) Storage Servers

**Chart 3. DS4500 RAID-5 Streaming Writes vs. DS4400 RAID-5 Streaming Writes**

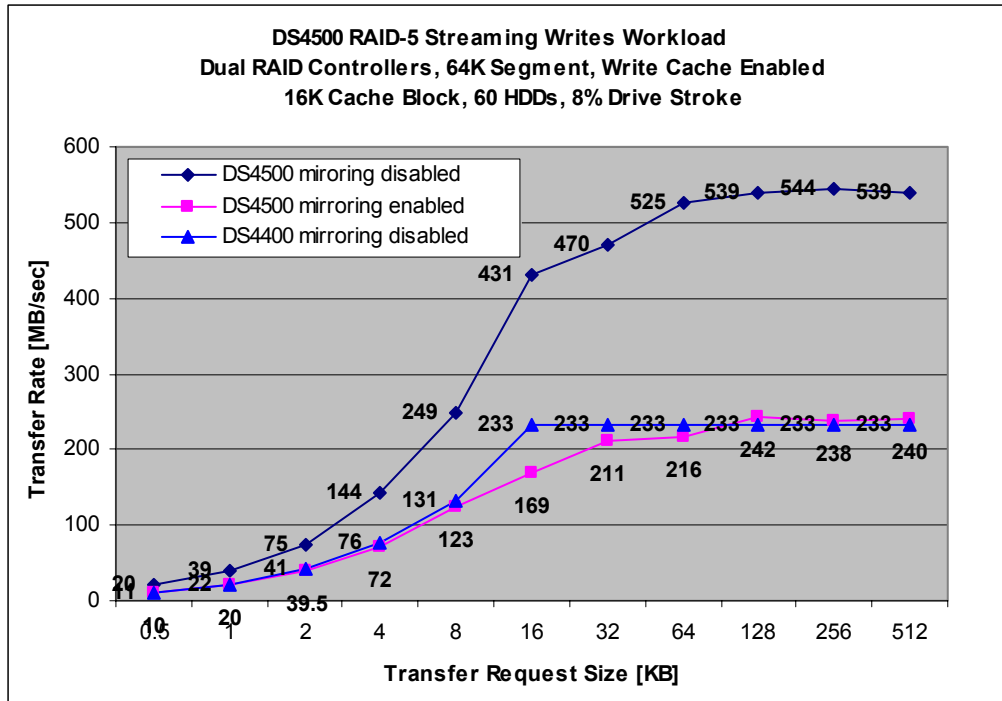

The DS4400 transfer rate for 64K transfer requests is 233MBps, and the DS4500 transfer rate for 64K transfer requests is 525MBps. The DS4400 maximum transfer rate for streaming writes is approximately 240MBps. Therefore, the DS4500 performs approximately 118% better than the DS4400 for 64K transfers for the RAID-5 Streaming Writes workload.

The DS4500 Storage Server performs approximately 70% to 120% better than the DS4400 Storage Server for the RAID-5 Streaming Writes workload over a transfer request range of 512 bytes to 512KB utilizing 60 HDDs.

### RAID-5 File Server and Static Web Server Workload Results

Table 3 contains the results of the File Server and the Static Web Server workload measurements. The results should not be interpreted as, for example, “This is what a user would see if the user attached a DS4500 Storage Server to a machine that is designated to be a file server or static Web server.” There are too many other factors involved with that line of thinking that might influence performance as well, such as the number of active users accessing files, the type of machine being used as the file server or Web server, and the general characteristics of the production workload, to name a few.

The File Server and Static Web Server workloads are used primarily to track product performance, serve as a comparison between similar products, and exercise a product with a workload that consists of various transfer request sizes as opposed to a uniform transfer request size.

**Comparison of the Raw Performance of the DS4500 (FAStT900) and DS4400 (FAStT700) Storage Servers**

**Table 3. DS4500 RAID-5 File Server and Static Web Server Transfer Rates\***

Workload		File Server [MBps]	Static Web Server [MBps]
<b>RAID-5</b>			
<b>20 HDDs</b>	All Caches Disabled	35	90
	Write Cache Enabled	42	N/A
<b>60 HDDs</b>	All Caches Disabled	105	238
	Write Cache Enabled	117	N/A
<b>100 HDDs</b>	All Caches Disabled	133	245
	Write Cache Enabled	131	N/A
<b>140 HDDs</b>	All Caches Disabled	133	246
	Write Cache Enabled	132	N/A
<b>180 HDDs</b>	All Caches Disabled	133	242
	Write Cache Enabled	132	N/A

\*Results correspond to an average response time of 20 ms.

Notice that the IOps and transfer rate tend to level off in the bottom half of the table as did the OLTP results in Table 1. For example, following the File Server column down, it can be observed that the transfer rate does not increase from 100 HDDs to 180 HDDs. This means that 133MBps is the maximum transfer rate for the Iometer File Server workload that dual DS4500 RAID controllers can achieve.

Chart 4 illustrates a comparison of the DS4500 and DS4400 executing the File Server workload. Sampling the data at an average response time of 20 ms yields a transfer rate of 133MBps for the DS4500 and 114MBps for the DS4400. The DS4500 performs approximately 16% better than the DS4400 for the RAID-5 File Server workload with 140 HDDs. The DS4400 was measured using the same hardware and software as the DS4500 for this comparison.

The DS4500 Storage Server performs approximately 5% to 15% better than the DS4400 Storage Server for the RAID-5 File Server workload depending on the number of HDDs utilized.

**Comparison of the Raw Performance of the DS4500 (FAStT900) and DS4400 (FAStT700) Storage Servers**

**Chart 4. RAID-5 DS4500 File Server Workload vs. DS4400 File Server Workload**

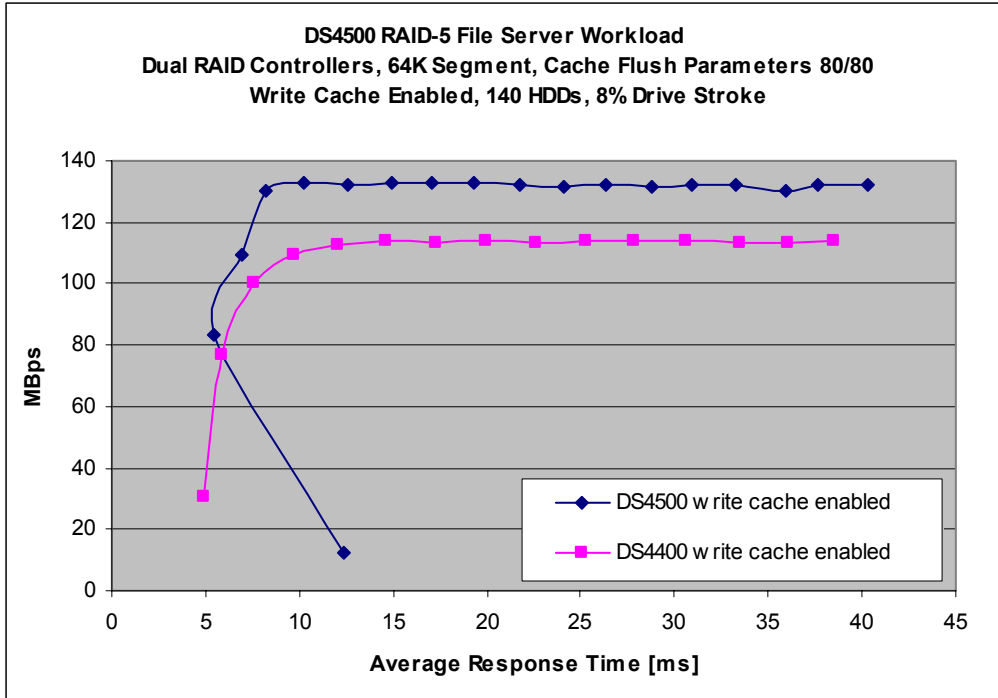

**Comparison of the Raw Performance of the DS4500 (FAStT900) and DS4400 (FAStT700)  
Storage Servers**

**RAID-5 Random Reads and Random Writes Workload Results**

Table 4 contains the results for the Random Reads 4K and 8K workloads, and the results for the Random Writes 4K and 8K workloads. Like the File Server workload and Web Server workload, these random read and write workloads are used to track product performance and serve as a comparison between similar products. In addition, these workloads are found in some production environments.

**Table 4. DS4500 RAID-5 Random Reads and Random Writes IOps\***

Workload		Random Reads 4K		Random Reads 8K		Random Writes 4K		Random Writes 8K	
		IOps	MBps	IOps	MBps	IOps	MBps	IOps	MBps
<b>RAID-5</b>									
<b>20 HDDs</b>	All Caches Disabled	8670	33.5	8365	65	898	3.5	890	6.5
	Write Cache Enabled	N/A	N/A	N/A	N/A	1100	4	460	3.5
<b>60 HDDs</b>	All Caches Disabled	25,080	97	24,395	190	2710	10.5	2640	20.5
	Write Cache Enabled	N/A	N/A	N/A	N/A	5015	19	5050	39
<b>100 HDDs</b>	All Caches Disabled	36,650	143	30,180	235	4480	17.5	4275	33
	Write Cache Enabled	N/A	N/A	N/A	N/A	8835	34	7675	60
<b>140 HDDs</b>	All Caches Disabled	42,555	166	30,020	234	6100	23	5700	44.5
	Write Cache Enabled	N/A	N/A	N/A	N/A	11,000	43	8325	65
<b>180 HDDs</b>	All Caches Disabled	40,900	159	29,480	230	7000	27.5	6285	49
	Write Cache Enabled	N/A	N/A	N/A	N/A	10,000	39	8400	65.5

\*Results correspond to an average response time of 20 ms.

It is important to note the “all caches disabled” results for the Random Writes 4K and 8K workload. The performance is significantly lower than the “write cache enabled” results. The reason is that when the write cache is disabled for this workload in a RAID-5 environment, the performance is severely degraded due to the read-modify-write disk operation required for each write request. With the write-back cache enabled, the entire stripe set can be retrieved at once, and all updates can be done within the cache, eliminating the need for separate disk-read-modify-write operations to each individual stripe unit. Once the entire RAID-5 stripe set has been modified in cache, the stripe set can be written directly to disk. See the IBM Redbook, “Tuning IBM eServer xSeries Servers for Performance,” for a review of the RAID levels. In production, a user would be well-advised to enable write caching in order to reap the benefits provided by the DS4000 implementation of the RAID-5 algorithm. Chart 5 illustrates the benefits of enabling write cache for a workload that consists of a large percentage of data modifications.

## Comparison of the Raw Performance of the DS4500 (FAStT900) and DS4400 (FAStT700) Storage Servers

Chart 5. DS4500 RAID-5 Random Writes 8K Workload

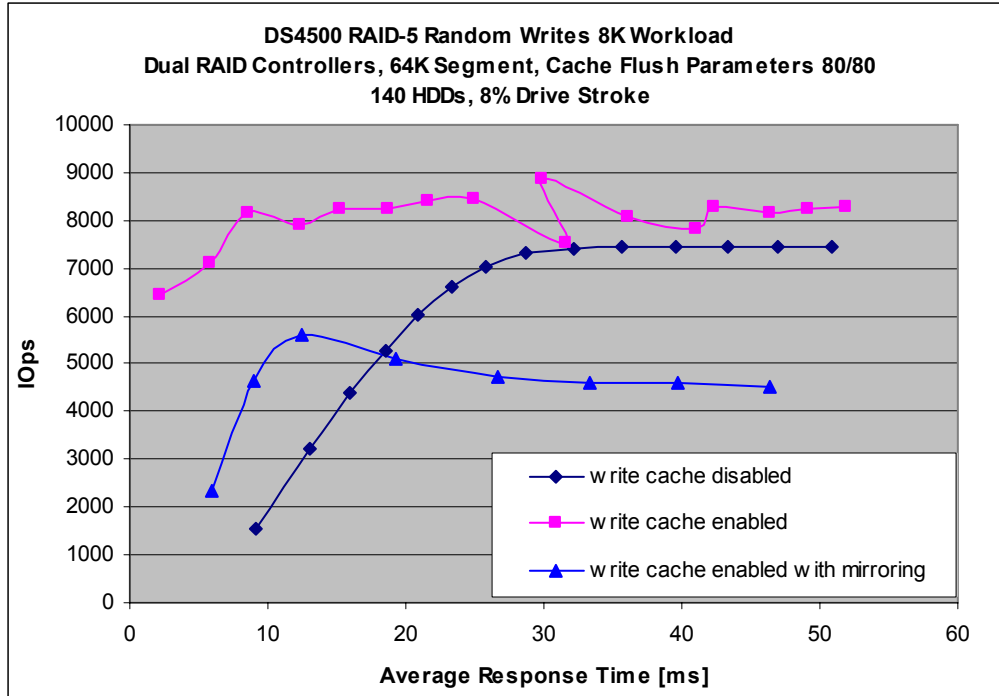

The Random Reads workload can be used to compare the performance of the DS4500 to the DS4400. Chart 6 illustrates this comparison.

## Comparison of the Raw Performance of the DS4500 (FAStT900) and DS4400 (FAStT700) Storage Servers

Chart 6. RAID-5 DS4500 8K Random Reads vs. DS4400 8K Random Reads

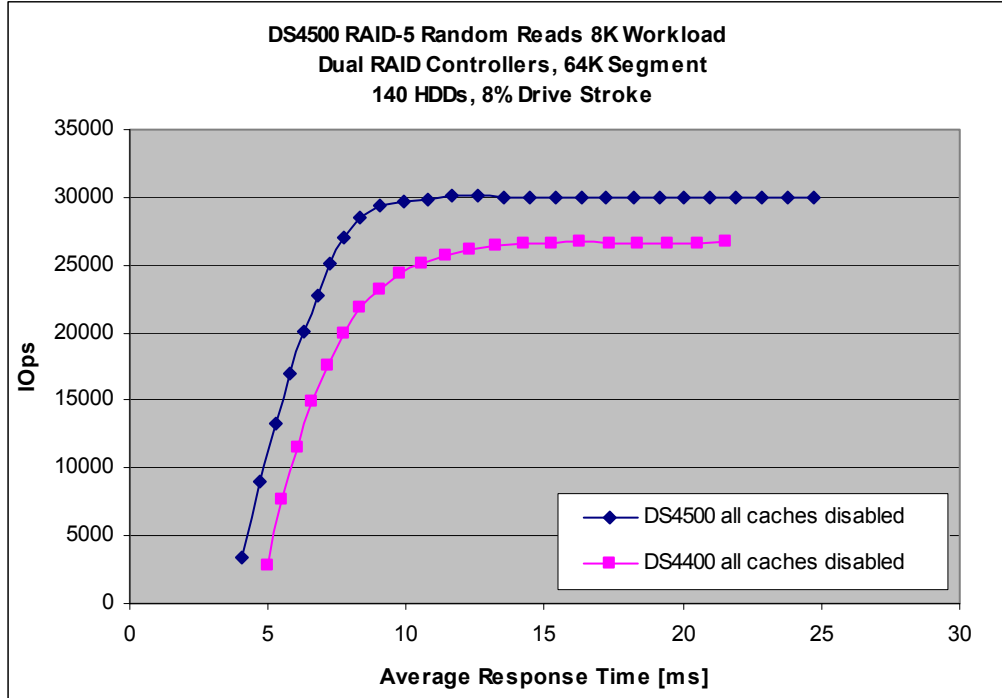

With 140 drives attached, the DS4500 is capable of achieving approximately 30,020 8K IOPS. The DS4400 is capable of achieving approximately 26,640 8K IOPS. Therefore, the DS4500 performs approximately 13% better than the DS4400 for the RAID-5 Random Reads workload with 140 HDDs.

The DS4500 Storage Server performs approximately 5% to 15% better than the DS4400 Storage Server for the RAID-5 Random Reads 8K workload depending on the number of HDDs utilized.

**Comparison of the Raw Performance of the DS4500 (FAStT900) and DS4400 (FAStT700)  
Storage Servers**

**RAID-10 OLTP Workload Results**

The RAID-10 results will contain the same tables and charts as the RAID-5 results. The examples, interpretations, and so forth used with the RAID-5 results will not be repeated with the RAID-10 results. However, there will be comparisons of DS4500 performance and DS4400 performance.

Table 5 contains RAID-10 measurement results for the OLTP workload for various transfer request sizes. The data in Table 5 corresponds to the results achieved at an average response time of 20 ms.

**Table 5. DS4500 RAID-10 OLTP IOps\***

Workload		OLTP 4K		OLTP 8K		OLTP 16K		OLTP 32K		OLTP 64K	
RAID-10		IOps	MBps	IOps	MBps	IOps	MBps	IOps	MBps	IOps	MBps
<b>20 HDDs</b>	All Caches Disabled	5040	19	4840	37.5	4475	70	3440	107	2780	173
	Write Cache Enabled	5895	23	5660	44	5185	81	3975	124	2800	174
<b>60 HDDs</b>	All Caches Disabled	15,425	60	15,000	117	13,455	210	8420	262	4585	286
	Write Cache Enabled	15,435	60	15,000	117	14,400	225	8700	272	5065	316
<b>100 HDDs</b>	All Caches Disabled	25,125	98	23,425	183	14,575	227	8450	264	4580	286
	Write Cache Enabled	26,100	102	23,800	186	15,500	242	9370	292	5070	316
<b>140 HDDs</b>	All Caches Disabled	30,480	118	23,450	183	14,485	226	8425	263	4570	286
	Write Cache Enabled	34,330	134	25,075	195	16,240	253	9430	294	5080	317
<b>180 HDDs</b>	All Caches Disabled	25,450	99	21,735	169	14,600	228	8535	266	4630	289
	Write Cache Enabled	25,225	98.5	25,330	198	16,350	255	9380	293	5060	316

\*Results correspond to an average response time of 20 ms.



## Comparison of the Raw Performance of the DS4500 (FAStT900) and DS4400 (FAStT700) Storage Servers

Table 6 contains information that can be used to approximate the performance of the DS4500 Storage Server in a RAID-10 OLTP environment assuming different working data set sizes.

**Table 6. RAID-10 OLTP Drive Stroke Percentage Multiplier**

Transfer Request Size	To approximate the RAID-10 OLTP IOPs for the following disk stroke percentages, multiply the 8% disk stroke IOPs from Table 1 by the corresponding multiplier...					
	15%	30%	45%	60%	75%	90%
RAID-10 OLTP 4K, 8K, and 16K	0.95	0.82	0.80	0.72	0.72	0.67

The same trend observed for the RAID-5 measurements (i.e., drive performance decreases as the drive stroke percentage increases) is clearly observed in Table 6.

Chart 7 illustrates the performance of dual DS4500 RAID controllers and dual DS4400 RAID controllers for the RAID-10 OLTP 8K workload.

**Chart 7. DS4500 RAID-10 OLTP 8K vs. DS4400**

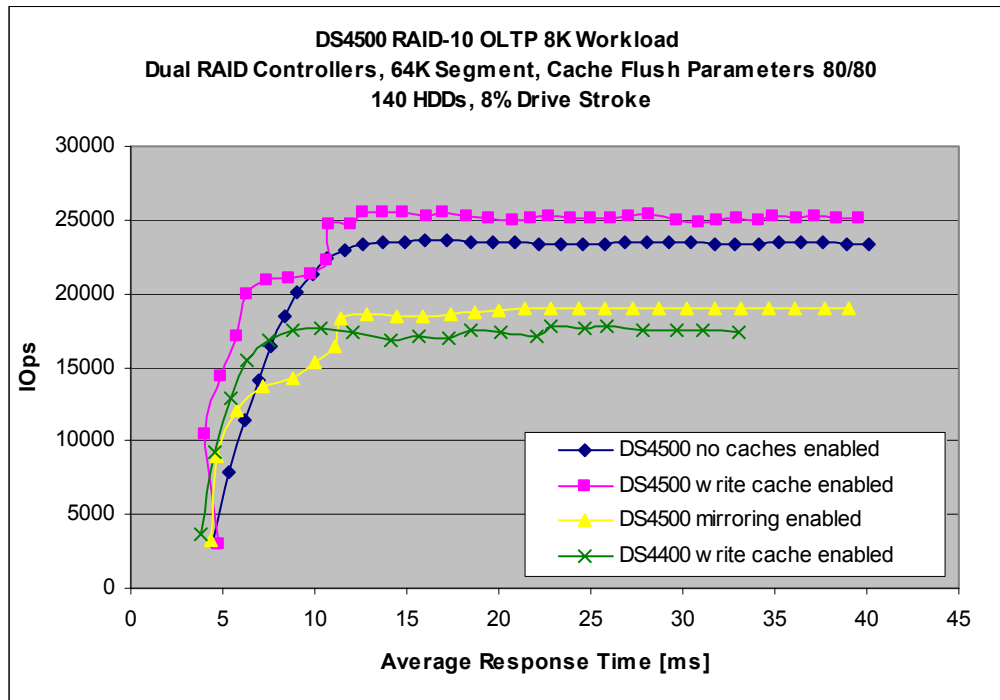

Comparing the “DS4500 write cache enabled” and “DS4400 write cache enabled” curves in Chart 7, and sampling the data that corresponds to a 20 ms average response time reveals that the DS4500 performs approximately 45% better than the DS4400 for the RAID-10 OLTP 8K workload utilizing 140 HDDs. The DS4400 was measured using the same hardware and software as the DS4500 for this comparison.

The DS4500 Storage Server performs approximately 5% to 45% better than the DS4400 Storage Server for the RAID-10 OLTP 8K workload depending on the number of HDDs utilized.

## Comparison of the Raw Performance of the DS4500 (FAStT900) and DS4400 (FAStT700) Storage Servers

### RAID-10 Streaming Reads and Streaming Writes Workload Results

Chart 8 illustrates the RAID-10 Streaming Reads performance of dual DS4500 RAID controllers versus dual DS4400 RAID controllers. The DS4400 was measured with 96 10K rpm HDDs, a 64K segment, a read-ahead multiplier of 8 (prefetch x8), and version 5.0 firmware.

**Chart 8. DS4500 RAID-10 Streaming Reads Transfer Rate**

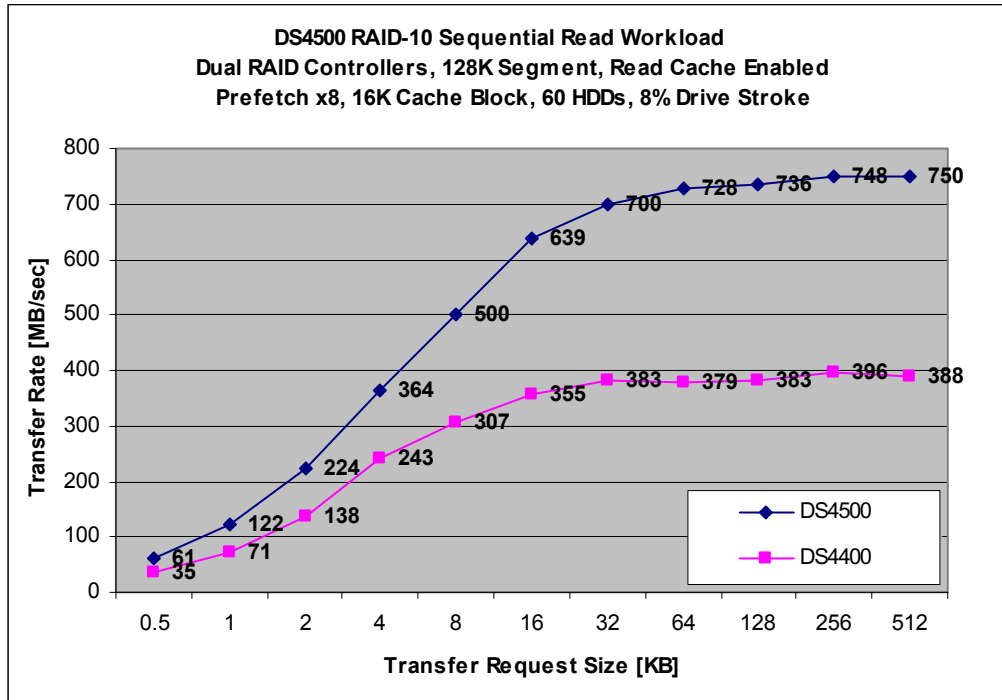

The DS4400 transfer rate for 64K transfer requests is 379MBps, and the DS4500 transfer rate for 64K transfer requests is 728MBps. After compensating for older drive technology by boosting the DS4400 transfer rate by 5% for the same reason explained for the RAID-5 Streaming Reads workload results, the DS4500 performs approximately 83% better than the DS4400 for 64K transfers for the RAID-10 Streaming Reads workload.

The DS4500 Storage Server performs approximately 50% to 85% better than the DS4400 Storage Server for the RAID-10 Streaming Reads workload over a transfer request range of 512 bytes to 512KB utilizing 60 HDDs.

Chart 9 illustrates the RAID-10 Streaming Writes performance of dual DS4500 RAID controllers versus dual DS4400 RAID controllers. The DS4400 was measured using 58 10K rpm HDDs, a 64K segment, write cache enabled, write cache mirroring disabled, and version 5.0 firmware.

## Comparison of the Raw Performance of the DS4500 (FAStT900) and DS4400 (FAStT700) Storage Servers

**Chart 9. DS4500 RAID-10 Streaming Writes Transfer Rate**

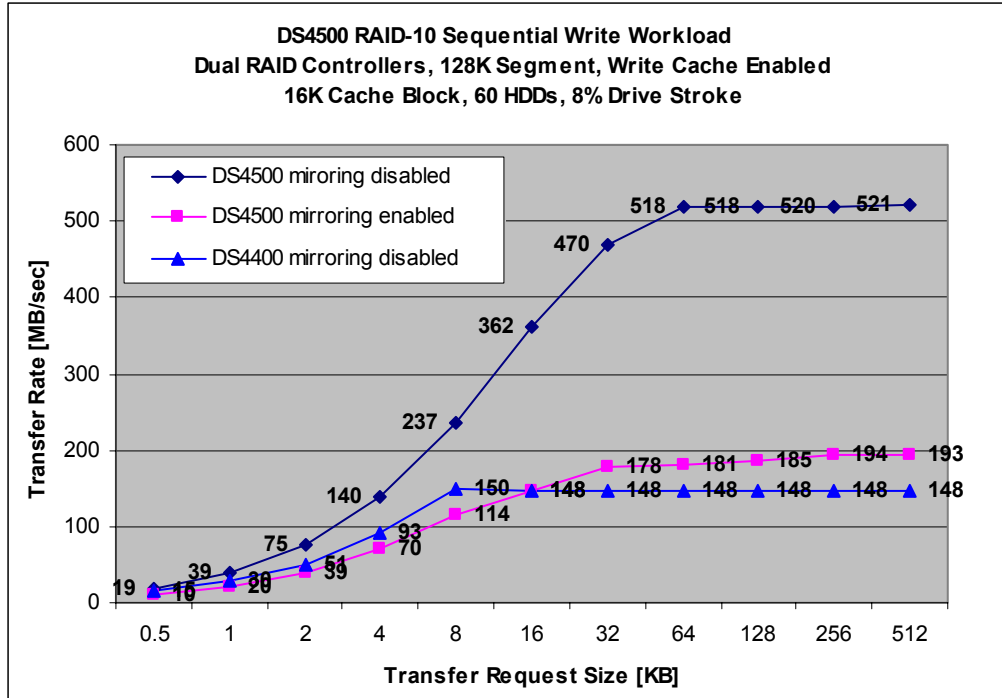

The DS4400 transfer rate for 64K transfer requests is 148MBps, and the DS4500 transfer rate for 64K transfer requests is 518MBps. After boosting the DS4400 performance by 5% because of the older drive technology, the DS4500 performs approximately 230% better than the DS4400 for 64K transfers for the RAID-10 Streaming Writes workload.

The DS4500 Storage Server performs approximately 40% to 230% better than the DS4400 Storage Server for the RAID-10 Streaming Writes workload over a transfer request range of 512 bytes to 512KB utilizing 60 HDDs.

### RAID-10 File Server and Static Web Server Workload Results

Table 7 contains the results of the File Server and the Static Web Server workload measurements. The same warning stated in the RAID-5 File Server / Web Server section for interpreting these results applies in this section, as well.

The File Server and Static Web Server workloads are used primarily to track product performance, serve as a comparison between similar products, and exercise a product with a workload that consists of various transfer request sizes.

**Comparison of the Raw Performance of the DS4500 (FAStT900) and DS4400 (FAStT700) Storage Servers**

**Table 7. DS4500 RAID-10 File Server and Static Web Server Transfer Rate\***

Workload		File Server [MBps]	Static Web Server [MBps]
<b>RAID-10</b>			
<b>20 HDDs</b>	All Caches Disabled	52	89
	Write Cache Enabled	54	N/A
<b>60 HDDs</b>	All Caches Disabled	155	238
	Write Cache Enabled	156	N/A
<b>100 HDDs</b>	All Caches Disabled	173	246
	Write Cache Enabled	171	N/A
<b>140 HDDs</b>	All Caches Disabled	188	246
	Write Cache Enabled	186	N/A
<b>180 HDDs</b>	All Caches Disabled	189	242
	Write Cache Enabled	191	N/A

\*Results correspond to an average response time of 20 ms.

Chart 10 illustrates a comparison of the DS4500 and DS4400 executing the File Server workload. Sampling the data at an average response time of 20 ms yields a transfer rate of 186MBps for the DS4500 and 163MBps for the DS4400. The DS4500 performs approximately 14% better than the DS4400 for the RAID-10 File Server workload with 140 HDDs. The DS4400 was measured using the same hardware and software as the DS4500 for this comparison.

**Chart 10. DS4500 RAID-10 File Server Workload vs. DS4400 File Server Workload**

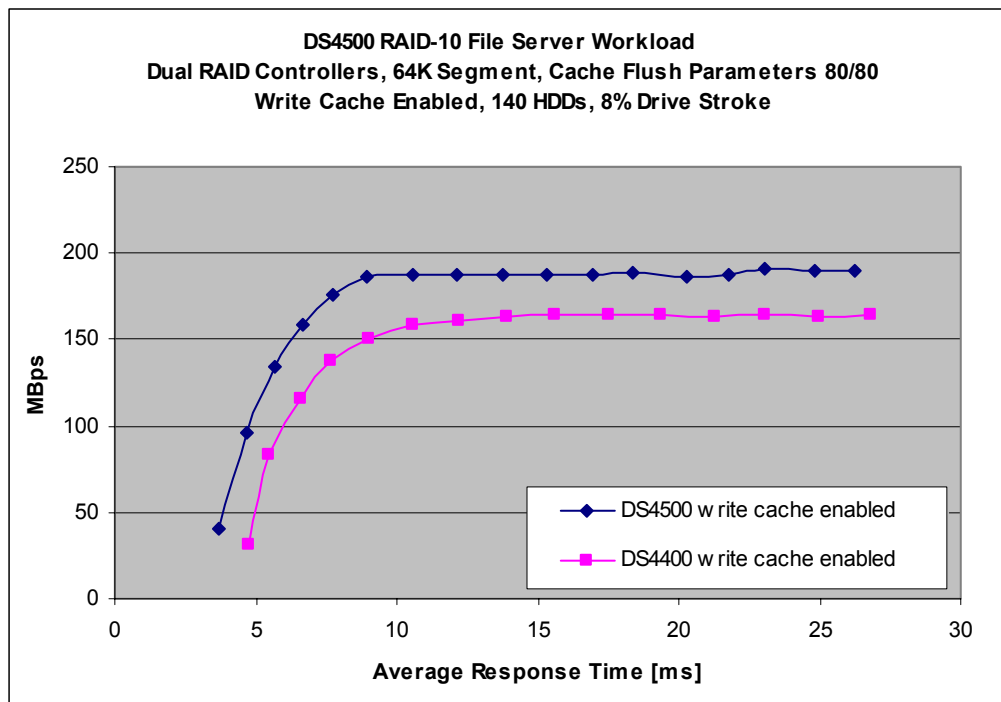

The DS4500 Storage Server performs approximately 5% to 15% better than the DS4400 Storage Server for the RAID-10 File Server workload depending on the number of HDDs utilized.

## Comparison of the Raw Performance of the DS4500 (FAStT900) and DS4400 (FAStT700) Storage Servers

### RAID-10 Random Reads and Random Writes Workload Results

Table 8 contains the results for the Random Reads 4K and 8K workloads, and the results for the Random Writes 4K and 8K workloads. Like the File Server workload and Web Server workload, these random read and write workloads are used to track product performance and serve as a comparison between similar products. In addition, these workloads are found in some production environments.

**Table 8. DS4500 RAID-10 Random Reads and Random Writes IOps\***

Workload		Random Reads 4K		Random Reads 8K		Random Writes 4K		Random Writes 8K	
		IOps	MBps	IOps	MBps	IOps	MBps	IOps	MBps
<b>RAID-10</b>									
<b>20 HDDs</b>	All Caches Disabled	8600	33	8300	64	2800	10	2770	21
	Write Cache Enabled	N/A	N/A	N/A	N/A	5895	23	5965	46
<b>60 HDDs</b>	All Caches Disabled	25,170	98	24,330	190	8630	33	8400	65
	Write Cache Enabled	N/A	N/A	N/A	N/A	9360	36	9050	70
<b>100 HDDs</b>	All Caches Disabled	36,430	142	30,260	236	11,000	42	9690	75
	Write Cache Enabled	N/A	N/A	N/A	N/A	12,875	50	11,175	86
<b>140 HDDs</b>	All Caches Disabled	42,500	166	30,060	234	16,245	63	13,900	108
	Write Cache Enabled	N/A	N/A	N/A	N/A	17,170	67	15,960	124
<b>180 HDDs</b>	All Caches Disabled	40,760	159	29,485	230	13,160	51	11,615	90
	Write Cache Enabled	N/A	N/A	N/A	N/A	15,275	59	12,775	99

\*Results correspond to an average response time of 20 ms.

Chart 11 illustrates the performance of the DS4500 for a RAID-10 Random Writes 8K workload.

**Chart 11. DS4500 RAID-10 Random Writes 8K Workload**

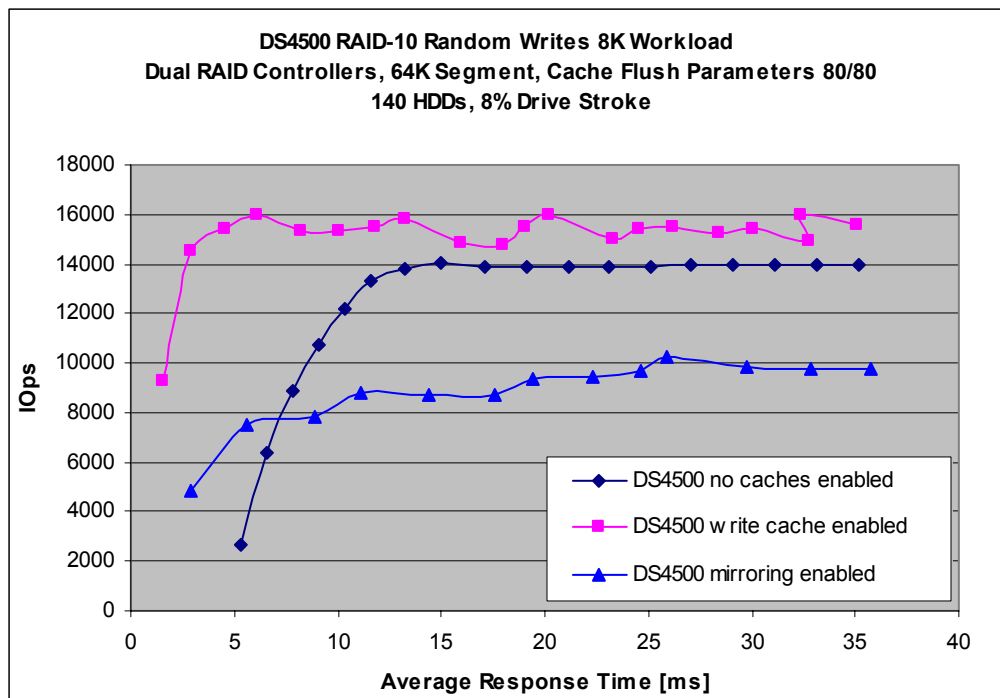

The Random Reads workload can be used to compare the performance of the DS4500 to the DS4400. Chart 12 illustrates this comparison.

## Comparison of the Raw Performance of the DS4500 (FAStT900) and DS4400 (FAStT700) Storage Servers

Chart 12. RAID-10 DS4500 8K Random Reads vs. DS4400 8K Random Reads

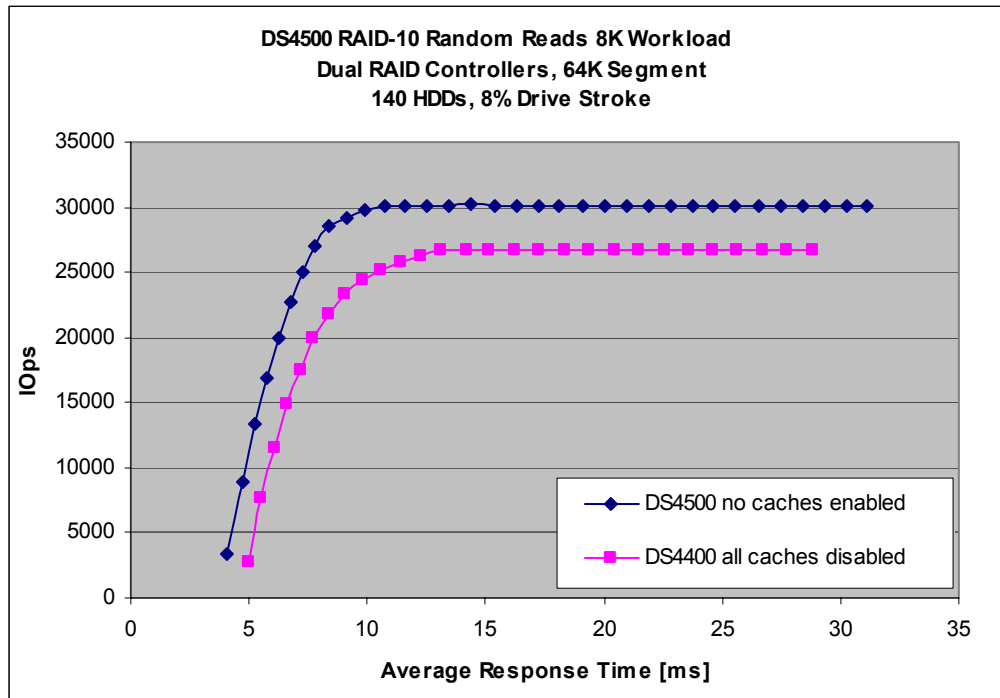

With 140 drives attached, the DS4500 is capable of achieving approximately 30,060 8K IOPs. The DS4400 is capable of achieving approximately 26,700 8K IOPs. Therefore, the DS4500 performs approximately 13% better than the DS4400 for the RAID-10 Random Reads workload with 140 HDDs.

The DS4500 Storage Server performs approximately 5% to 15% better than the DS4400 Storage Server for the RAID-10 Random Reads 8K workload depending on the number of HDDs utilized.

## Summary

The DS4500 offers substantial performance improvement over its predecessor, the DS4400. Some examples of the approximate performance gains are:

### RAID-5

- 5% to 30% for OLTP 8K workload
- 50% to 75% for Streaming Reads workload (60 HDDs)
- 70% to 120% for Streaming Writes workload (60 HDDs)
- 5% to 15% for File Server workload
- 5% to 15% for Random Reads workload

### RAID-10

- 5% to 45% for OLTP 8K workload
- 50% to 85% for Streaming Reads workload (60 HDDs)
- 40% to 230% for Streaming Writes workload (60 HDDs)
- 5% to 15% for File Server workload
- 5% to 15% for Random Reads workload

## Comparison of the Raw Performance of the DS4500 (FAStT900) and DS4400 (FAStT700) Storage Servers



© IBM Corporation 2004

IBM Systems and Technology Group

Department MX5

Research Triangle Park NC 27709

Produced in the USA

9-04

All rights reserved.

IBM, the IBM and eServer logos, eServer, TotalStorage, ServeRAID and xSeries are trademarks or registered trademarks of IBM Corporation in the United States and/or other countries.

Pentium and Xeon are trademarks or registered trademarks of Intel Corporation.

Microsoft and Windows are trademarks or registered trademarks of Microsoft Corporation in the United States and/or other countries.

Other company, product, and service names may be trademarks or service marks of others.

The performance data contained herein was obtained in a controlled, isolated environment. Actual results that may be obtained in other operating environments may vary significantly. While IBM has reviewed each item for accuracy in a specific situation, there is no guarantee that the same or similar results will be obtained elsewhere.

The responsibility for use of this information or the implementation of any of these techniques is a customer responsibility and depends on the customer's or user's ability to evaluate and integrate them into their operating environment. Customers or users attempting to adapt these techniques to their own environments do so at their own risk. In no event shall IBM be liable for any damage arising from the use of this information, including but not limited to, loss of data, business interruption, loss of profit or loss of opportunity.

IBM reserves the right to change specifications or other product information without notice. References in this publication to IBM products or services do not imply that IBM intends to make them available in all countries in which IBM operates. IBM PROVIDES THIS PUBLICATION "AS IS" WITHOUT WARRANTY OF ANY KIND, EITHER EXPRESS OR IMPLIED, INCLUDING THE IMPLIED WARRANTIES OF MERCHANTABILITY AND FITNESS FOR A PARTICULAR PURPOSE. Some jurisdictions do not allow disclaimer of express or implied warranties in certain transactions; therefore, this statement may not apply to you.

IBM xSeries servers are assembled in the U.S., Great Britain, Japan, Australia and Brazil and are composed of U.S. and non-U.S. parts.

This publication may contain links to third party sites that are not under the control of or maintained by IBM. Access to any such third party site is at the user's own risk and IBM is not responsible for the accuracy or reliability of any information, data, opinions, advice or statements made on these sites. IBM provides these links merely as a convenience and the inclusion of such links does not imply an endorsement.