

# InfoPrint Transform Manager for Linux: Installation and User's Guide

*Version 1 Release 2.5*



# InfoPrint Transform Manager for Linux: Installation and User's Guide

*Version 1 Release 2.5*

**Note:**

Before using this information and the product it supports, read the general information in “Notices” in the “Transform Manager overview” section.

| This edition applies to InfoPrint Transform Manager for Linux Version 1 Release 2 Modification 5 (PTF U810978  
| November 2007), Program Number 5639-P51, and to all subsequent releases and modifications until otherwise  
| indicated in new editions.

This edition replaces S550-0391-05.

**Internet**

Visit our home page: <http://www.infoprint.com>

You can send comments by e-mail to [printpubs@us.ibm.com](mailto:printpubs@us.ibm.com) or by mail to:

InfoPrint Solutions Company, LLC  
6300 Diagonal Highway 002J  
Boulder, CO 80301-9270  
U.S.A.

© Copyright InfoPrint Solutions Company 2004, 2007. All rights reserved.

---

# Contents

<b>About this publication</b> . . . . .	v
Who should read this publication . . . . .	v
Related information . . . . .	v
<b>Chapter 1. Transform Manager overview</b> . . . . .	1
Highlights . . . . .	1
How it works . . . . .	2
InfoPrint Transform Manager user interface . . . . .	4
Banner area . . . . .	5
Transform Manager main page . . . . .	5
Set Transform Server properties for <i>host</i> . . . . .	7
Accessibility . . . . .	8
System requirements . . . . .	9
Notices . . . . .	10
Trademarks . . . . .	12
<b>Chapter 2. Installing InfoPrint Transform Manager for Linux</b> . . . . .	15
Installing the Transform Manager on xSeries servers using the InstallShield Wizard . . . . .	15
Installing the Transform Manager on xSeries servers from the command line	16
Installing InfoPrint Transform Manager on an IBM eServer BladeCenter . . . . .	17
Installing a Transform Manager compute node on an IBM eServer BladeCenter . . . . .	17
Installing an InfoPrint Transform Manager head node and user interface on an IBM eServer BladeCenter . . . . .	18
Logging in to the Transform Manager . . . . .	18
<b>Chapter 3. Configuring InfoPrint Transform Manager</b> . . . . .	21
Changing passwords . . . . .	21
Adding a transform server . . . . .	21
Adding a print server . . . . .	22
Configuring InfoPrint Manager for AIX and Windows for use with Transform Manager . . . . .	22
Authorizing the Transform Manager user ID . . . . .	22
Adding the print server for InfoPrint Manager . . . . .	23
Testing the InfoPrint Manager print server configuration . . . . .	23
Configuring InfoPrint ProcessDirector for use with Transform Manager . . . . .	24
Adding a print server for InfoPrint ProcessDirector . . . . .	24
Testing the InfoPrint ProcessDirector print server configuration . . . . .	24
Configuring Infoprint Server for z/OS for use with Transform Manager . . . . .	25
Customizing Infoprint Server for z/OS for use with Transform Manager . . . . .	25
Testing the Infoprint Server for z/OS print server configuration . . . . .	25
<b>Chapter 4. Working with transform servers</b> . . . . .	27
Logging in to the Transform Manager . . . . .	27
Starting transform servers . . . . .	27
Stopping transform servers . . . . .	28
Removing transform servers . . . . .	28
Displaying job information for a transform server . . . . .	28
Displaying specific messages for a transform server . . . . .	28
Displaying specific job history for a transform server . . . . .	29
Changing transform server information . . . . .	29
Resetting Transform Manager . . . . .	29

	Reset Transform Manager . . . . .	30
	Managing transform servers . . . . .	30
	Understanding file directories. . . . .	30
	<b>Chapter 5. Working with print servers</b> . . . . .	<b>31</b>
	Reconnecting print servers . . . . .	31
	Removing print servers . . . . .	31
	Changing print server definitions . . . . .	32
	Managing print servers . . . . .	32
	<b>Chapter 6. Working with resources.</b> . . . . .	<b>33</b>
	Resources distributor . . . . .	33
	Copying resources . . . . .	34
	Resource packaging scripts . . . . .	34
	<b>Chapter 7. Updating InfoPrint Transform Manager with Service Packs</b> . . . . .	<b>37</b>
	Updating Transform Manager from the Web site. . . . .	37
	Updating Transform Manager from a service CD-ROM with InstallShield. . . . .	37
	Updating Transform Manager with a service CD-ROM from the command line . . . . .	38
	<b>Chapter 8. Uninstalling InfoPrint Transform Manager.</b> . . . . .	<b>41</b>
	Uninstalling Transform Manager from an IBM xSeries server . . . . .	41
	Uninstalling Infoprint Transform Manager from an IBM eServer BladeCenter . . . . .	41
	Uninstalling Transform Manager from the Linux command line . . . . .	41
	<b>Chapter 9. Troubleshooting Transform Manager</b> . . . . .	<b>43</b>
	Troubleshooting with InfoPrint Manager . . . . .	43
	Troubleshooting with InfoPrint ProcessDirector . . . . .	43
	Troubleshooting with Infoprint Server for z/OS . . . . .	43
	Configuring a trace for a transform server . . . . .	43
	<b>Chapter 10. Reference information for Transform Manager</b> . . . . .	<b>45</b>
	Using the transforms. . . . .	45
	Transform GIF data to AFP . . . . .	45
	Transform JPEG data to AFP . . . . .	58
	Transform PCL data to AFP . . . . .	71
	Transform PDF or PostScript data to AFP . . . . .	82
	Transform SAP OTF or ABAP data to AFP. . . . .	91
	Transform TIFF data to AFP . . . . .	104
	Reading Syntax Diagrams . . . . .	119
	Usage notes for Transform Manager . . . . .	121
	Transform Manager messages. . . . .	121
	Transform Manager transform IDs . . . . .	129
	<b>Glossary</b> . . . . .	<b>131</b>
	<b>Index</b> . . . . .	<b>135</b>

---

## About this publication

This publication provides information about InfoPrint Transform Manager for Linux™ Version 1 Release 2 Modification 5 licensed program (Program Number 5639-P51).

This publication includes an overview of InfoPrint Transform Manager for Linux (hereafter referred to as the Transform Manager), getting started information about the product, tasks that can be done with Transform Manager, a description of the transforms and messages included with the product, and the Transform IDs.

---

## Who should read this publication

This publication is for system administrators who need to install, operate, and maintain the Transform Manager. This publication can also be used by job submitters, who want to use the transforms provided with Transform Manager.

---

## Related information

For information about InfoPrint Manager, refer to these documents:

- *InfoPrint Manager: Reference*, S550-1052
- *InfoPrint Manager for AIX: Procedures*, G544-5815
- *InfoPrint Manager for Windows: Procedures*, G544-5814

For additional information about InfoPrint Solutions Company printing products, refer to these Web pages:

<http://www.infoprint.com>  
<http://publib.boulder.ibm.com/infocenter/printer/v1r1/index.jsp>





---

## Chapter 1. Transform Manager overview

This topic gives an overview of InfoPrint® Transform Manager for Linux, including highlights, how it works, and system requirements.

InfoPrint Transform Manager for Linux (hereafter referred to as the Transform Manager) is a scalable system that operates on a Linux workstation. The Transform Manager provides a powerful and cost-effective system for transforming print jobs from the input format to the output format. When data and image transforms are required for AFP™ printing, print servers, such as InfoPrint Manager for Windows®, InfoPrint Manager for AIX®, InfoPrint ProcessDirector, or Infoprint Server for z/OS, can send transform requests to the Transform Manager for processing across one or more transform servers.

You configure the print servers so that print jobs that require transformation are sent to the Transform Manager. The Transform Manager user interface lets you define both the print servers that are sending transform requests and the transform servers that are transforming the data. You can also use the user interface to start or stop transform servers, view a transform server message log, or turn tracing on or off for a transform server.

---

### Highlights

This topic describes the features of the Transform Manager.

The Transform Manager represents InfoPrint Solutions Company's strategic transform solution for multiplatforms. This component technology lets you centralize your transform programs in one location, eliminating the possibility of inconsistent transforms running on each platform. The Transform Manager provides a solid architecture for flexible integration of additional transforms.

The Transform Manager:

- Supports these data and raster image transforms to AFP:
  - Printer Control Language (PCL) at PCL6
  - Adobe Portable Document Format (PDF) Version 1.6 or below
  - Adobe PostScript (PS) Level 3
  - Graphics Interchange Format (GIF)
  - Joint Photographic Experts Group (JPEG)
  - Systems Applications and Products (SAP OTF and ABAP)
  - Tagged Image File Format (TIFF)
- PDF and PS transform requests are processed as groups of pages. GIF, JPEG, and TIFF transform requests are handled in parallel on a job basis.
- When the InfoPrint Transform Manager: *afp2pdf* Transform i-listed PRPQ, Program Number 5799-TWL, is purchased, Transform Manager supports the transform of AFP data to PDF data. For information about the **afp2pdf** transform, see *InfoPrint Transform Manager: afp2pdf Transform Installation and User's Guide*, G550-0538.
- Improves transform performance of large PDF jobs.
- Provides remote transform processing; Version 1.2 works with InfoPrint Manager for AIX, InfoPrint Manager for Windows, InfoPrint ProcessDirector, and Infoprint Server for z/OS.

- Input TIFF files must be less than 2 Gigabytes. That is, the **tiff2afp** transform does not support input files larger than 2 Gigabytes.
- The **gif2afp**, **jpeg2afp**, **pcl2afp**, **pdf2afp**, and **ps2afp** configuration files have been modified to support files larger than 2 Gigabytes.
- Support to install Transform Manager on an IBM eServer BladeCenter. A properly-configured IBM eServer BladeCenter can provide substantial additional transform processing power.
- Is printer independent.

---

## How it works

This topic describes how the Transform Manager works.

The Transform Manager handles data and image transform processing from print servers by balancing and managing transform requests across multiple transform servers. You interact with the Transform Manager through a user interface on a Web browser.

The Transform Manager includes these components:

### Coordinator

The coordinator communicates with these print servers:

- InfoPrint Manager for AIX and Windows
- InfoPrint ProcessDirector for AIX and Linux
- Infoprint Server for z/OS

The coordinator balances the transform requests across transform servers.

### Transform server

The transform server manages these print data and image transforms:

- PCL
- Adobe PDF and PostScript
- GIF
- JPEG
- SAP
- TIFF

The transforms convert the print data and image data to AFP data. For more information about the transforms, see “Using the transforms” on page 45.

### User interface

The user interface lets you define print servers to the Transform Manager and start, stop, and manage the transform servers.

If you install multiple, separately licensed Transform Manager systems, you can use the user interface from any installation to add and manage the transform servers from the other installations.

Transform Manager accepts transform requests from these print servers in Version 1.2: InfoPrint Manager for AIX, InfoPrint Manager for Windows, InfoPrint ProcessDirector, and Infoprint Server for z/OS (see “System requirements” on page 9 for the applicable versions).

Figure 1 on page 3 shows the Transform Manager components and how the Transform Manager interacts with the print servers.

**Note:** When you purchase the **afp2pdf** transform that is available as an I-listed PRPQ, 5799-TWL, you can transform AFP data to PDF data.

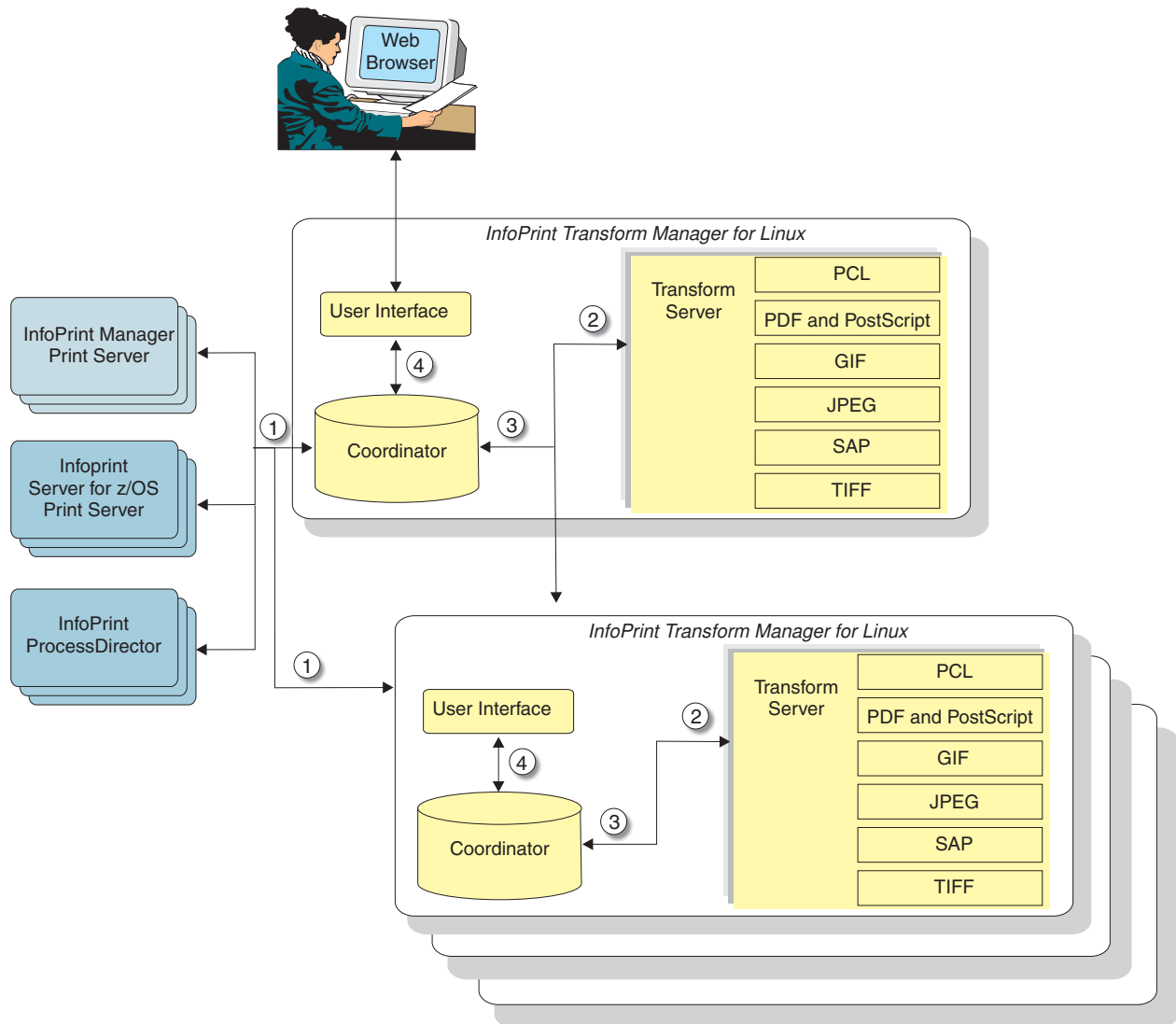

Figure 1. Transform Manager components and the interaction with print servers

The following numbered items correspond to the numbers in Figure 1. They describe how the components operate and interact with each other and the print servers.

1. Print jobs are submitted from one or more print servers that have been configured to send transform requests to the Transform Manager. A print server interface transmits the request to the coordinator. The coordinator component receives the request and information regarding the type of transformation to be performed.
2. The coordinator sends the transform request to a transform server component, which transforms the data with the appropriate transform, such as PostScript to AFP. If you are using more than one transform server, the coordinator sends the request to the transform server with the lowest processing load.

3. To maximize print server performance in sending data to the printers, the transform servers sequence the transformed data in the correct order and return it to the print servers as the data completes processing, instead of waiting for the entire job to finish.
4. The user interface component, which you access from a Web browser, lets you define which print servers and transform servers the Transform Manager communicates with. With the user interface, you can start and stop transform servers, check the operating status of the transform servers, determine the percentage of work pending for a transform server, view the message log, configure a trace to help diagnose a problem (only when requested by IBM® Software Support), and see what transforms are installed on a transform server.

## Returning transform requests from Transform Manager

If you submit numerous transform requests from a print server through the Transform Manager, those transform requests might not return to the print server in the same order. The order the transformed data returns to the print server depends on the kind of transform (AFP, PDF, PostScript, GIF, JPEG, SAP, or TIFF) and the size of the request.

For example, you send a PCL file and then you send a PDF file that is the same size. The PDF file, on the other hand, is processed as groups of pages over multiple processors. The PCL file can only be transformed on a job basis. Therefore, the PDF file might be transformed first and the Transform Manager might return it to the print server before the PCL file.

---

## InfoPrint Transform Manager user interface

The InfoPrint Transform Manager for Linux user interface is a Web-based interface that you can access from a workstation. The workstation must have either the Microsoft® Internet Explorer Web browser or the Firefox Web browser (also called Mozilla) for either Windows or Linux installed.

The Transform Manager interface uses standard interface controls, such as tables, drop-down lists boxes, and buttons.

The Transform Manager GUI consists of a Main page and other associated pages.

### Banner area

The Transform Manager user interface has a banner area at the top, which is always available from any page or task panel in the interface.

### The Transform Manager main page

The main page of the Transform Manager user interface contains two areas: Transform Servers and Print Servers.

### Viewing information on the help system

The online help in the Transform Manager user interface helps you use the pages and complete tasks. To use the help, do one of these:

- Select **Help** in the Banner Area to see a list of links to all of the help.
- Select the question mark on a field for help about that field.

## Accessibility

Accessibility features help a user who has a physical disability, such as restricted mobility or limited vision, use software products successfully.

## Banner area

The Infoprint Transform Manager user interface has a banner area at the top of each page, which is always available from any page or task panel in the interface.

From the banner area, you can click on:

### Preferences

Opens the **Change Login Password** page.

**Help** Opens the InfoPrint Transform Manager for Linux help system.

**About** Opens information about Infoprint Transform Manager for Linux.

The About page lets you see the version information for the Transform Manager, including the program number, installed component versions, Software Support contact information, and the product copyright. The About Page also contains the IP address, processor count, compute node count, and the Operating System version for the local Transform Server. The local Transform Server is the Transform Server that runs on the same machine as the Transform Manager whose GUI is currently being viewed. When the installation includes a blade installation, the About page shows the processor count and the compute node count for each blade. To view the About page, select **About** on any page in the user interface.

**Note:** If the user is not logged in, the Banner area only contains the **Help** and **About** choices.

### Related tasks

“Changing passwords” on page 21

If you want to change the password for Transform Manager, you need to know the current password.

## Transform Manager main page

This page lists the transform servers and print servers you can work with in the Transform Manager.

The **Transform Servers** section lists the transform servers that are defined to the Transform Manager.

The actions you can perform from the **Transform Servers** section are:

**Start** Initialize the selected transform server so it can start accepting new transform requests.

**Stop** Let the selected transform server complete processing current requests and then become unavailable to accept new transform requests.

**Add** Define a new transform server to the Transform Manager.

### Remove

Remove the selected transform servers from the Transform Manager.

### Export Traces

Export the log and trace information for the selected Transform Server.

## Actions

From the **Actions** drop-down menu, select **View Log** to display the Job Log for a transform server, **View History** to display the Job History for a transform server, or **Distribute resources** to open the **Resources distributor** window where you select resource files that you want to copy to another Transform Server.

The **Transform Servers** section contains these headings:

**Select** Indicates whether the transform server is selected for an action.

### Host Name

Specifies a host name that is a hyperlink to the host name or IP address of the transform server. When you click on the hyperlink, you open the **Set Transform Server properties for host**, where *host* is the host name or TCP/IP address of a transform server.

### Availability

This row contains an icon that is either a green light or a red light. Green indicates that the transform server is running. Red indicates that the transform server is not running. This row also contains an icon next to each green or red light that shows the Transform Server connection when the Transform Server status is either Ready or Transforming. This icon is constantly changing over a five to ten second interval if the connection is active. When the connection goes down, the icon does not change. This indicates that a problem has occurred with the Transform Server even if the status appears to be OK (Ready or Transforming).

### Status

This row contains a text string of the current server status: Starting, Ready, Transforming, Stopping, Stopped, or Lost Connection.

#### Starting

The transform server is initializing to accept new transform requests.

**Ready** The server is running and accepting jobs. No jobs are currently being transformed.

#### Transforming

The server is running and is accepting jobs. At least one job is being transformed, and one or more jobs may be in the queue.

#### Stopping

The server is in the process of stopping, and it is not accepting any new transform requests.

#### Stopped

The server has stopped accepting new transform requests.

#### Lost Connection

The connection to the server has been lost.

### CPU Utilization

Indicates a percent bar that shows how much of the CPU is being used. The CPU usage refers only to the machine that the Transform Server is running on.

### Jobs Queued

Indicates the number of jobs waiting in the queue to be transformed. Jobs that are transforming are not included in the jobs queued count.

**Jobs Processed**

Indicates the number of jobs that have been processed by the server since the server was started.

**Pages/Min.**

Indicates the average number of pages per minute for all the jobs that are already completed.

The **Print Servers** section lists the print servers that are defined to the Transform Manager. The print server actions you can perform are:

**Add** Define a new print server to the Transform Manager.

**Remove**

Remove the selected print servers from the Transform Manager.

**Reconnect**

Retry the connection to register with the selected print server.

The **Print Servers** section contains these headings:

**Select** Indicates whether the print server is selected for an action.

**Availability**

For InfoPrint Manager for AIX and Windows, this row contains an icon that is either a green light or a red light. Green indicates that the printer was successfully configured for Transform Manager. Red indicates that some problems occurred when the printer was configured. For other types of printers, this column contains no information.

**Host Name**

Indicates the host name or IP address of the print server.

**Server name**

Indicates the name of the print server, which might be the same as the host name.

**Type** Indicates the type of the print server, that is, Infoprint Manager, Infoprint ProcessDirector, or Infoprint Server.

**Port** Indicates the port number for the print server.

You can sort the tables on this page in ascending or descending order by selecting a column header.

The Transform Manager main Page is refreshed periodically in the background to display the latest statistics. Message boxes might appear at the top of the page to inform you about the result of some actions that needed time to complete or about changes in the status of the transform servers, print servers, or the coordinator.

**Note:** If the communication with the coordinator fails, the two tables are replaced by an error message. When this happens, you can press the **Reset ITM** button on the main page to restart Transform Manager. If this does not solve the problem, then you need to reboot the machine.

## Set Transform Server properties for *host*

The **Set Transform Server properties for *host*** (where *host* is the Host Name or TCP/IP address of a Transform Server) contains a list of the properties and values for the Transform Server. To access the properties page, click on the Host Name on the **Transform Manager** main page.

You can change any of the information on these pages that has an entry field except the entry fields that are grayed-out because they are read-only.

Properties are grouped on three tabs: General, Status, and Trace. You can view all of the properties at once by clicking **Show all tabs** in the left pane. After you have clicked **Show all tabs**, you can press **F5** to collapse the three tabs and display the **General** tab.

## General

You use the fields on this page to change properties for the Transform Server identified by *host* in the title of the page.

## Status

You use the fields on this page to view status information about the Transform Server identified by the *host* in the title of the page.

## Trace

You use the fields on this page to enable or disable tracing for the Transform Server identified by the *host* in the title of the page. However, you should use the **Trace** page only when InfoPrint Solutions Company Software Support asks you to run a trace to help diagnose a problem.

## Accessibility

Accessibility features are an important part of InfoPrint Transform Manager for Linux.

Accessibility features help a user who has a physical disability, such as restricted mobility or limited vision, use software products successfully. The major accessibility features in the Transform Manager let users:

- Use assistive technologies such as screen-readers and screen magnifier software.
- Operate specific or equivalent features using only the keyboard.
- Customize display attributes such as color, contrast, and font size.

### Using assistive technologies

Assistive technology products, such as screen-readers, function with the user interfaces found in the Transform Manager. Consult the assistive technology documentation for specific information when using it to access the Transform Manager.

### Keyboard navigation of the user interface

The Transform Manager user interface complies with the accessibility guidelines for HTML. Users can use keyboard shortcuts or function keys (PF keys) to access the Transform Manager user interface. Refer to your browser documentation for keyboard shortcuts and default settings for the PF keys and for explanations about how to modify their functions.



---

## System requirements

This topic describes the hardware and software requirements for using the Transform Manager.

### Hardware requirements

InfoPrint Solutions Company recommends you use an IBM xSeries® server that supports SUSE Linux Enterprise Server 9.0 SP3 (Service Pack 3) or SUSE Linux Enterprise Server 10.0 for x86. The server requirements are:

- Intel® 32-bit platform
- At least two 3.0 GHz or faster processors for single-core processors
- At least two 2.0 GHz or faster processors for multi-core processors
- The minimum amount of RAM installed must be the greater value from 2 GB and (512 MB \* number of compute nodes to be installed)
- CD-ROM drive

The IBM eServer BladeCenter requirements are:

- HS20 blade server that supports SUSE Linux Enterprise Server 9.0 SP3 or SUSE Linux Enterprise Server 10.0 with a minimum of two processors.
- Minimum of 1 GB RAM
- CD-ROM drive

### Software requirements

The Transform Manager requires this software:

Software	Installed on
SUSE Linux Enterprise Server 9.0 SP3 or SUSE Linux Enterprise Server 10.0 for x86 with automount feature enabled	Transform Manager server
InfoPrint Manager for AIX 4.2 with PTF U807769	Print server
InfoPrint Manager for Windows 2.2 with PTF U000352	Print server
InfoPrint ProcessDirector for AIX, V1R3	Print server
InfoPrint ProcessDirector for Linux, V1R3	Print server
Infoprint Server for z/OS V1R4 and higher. When you run Infoprint Server for z/OS V1R4 through V1R8 APAR OA18410 is required.	Print server
X Window System if you want to use the Graphical User Interface of InstallShield MultiPlatform Wizard to install the Transform Manager (recommended)	Transform Manager server
Microsoft Internet Explorer Web browser.	Workstation
Mozilla 1.7 or above Web browser from Firefox.	Workstation

Software	Installed on
<p><b>Usage considerations:</b></p> <ol style="list-style-type: none"> <li>1. You must have at least one print server, but you can have more than one.</li> <li>2. If you use the Firefox Web browser with InfoPrint ProcessDirector, you will be asked to log in whenever you switch between the Transform Manager GUI and the InfoPrint ProcessDirector GUI and want to perform an action. This does not occur with Microsoft Internet Explorer.</li> <li>3. The help system for InfoPrint Transform Manager for Linux is an IBM Eclipse Help System. This help system requires approximately 1.2 G of memory.</li> <li>4. When you install InfoPrint Transform Manager for Linux, Version 1 Release 2 Modification 5, you must also install Mozilla 1.7 or above.</li> <li>5. With InfoPrint Transform Manager for Linux, Version 1 Release 2 Modification 5, the supported versions of these products have changed as indicated in <b>bold font</b>: <ul style="list-style-type: none"> <li>• IBM Embeddable WebSphere Application Server, <b>Version 6.1.0.7</b></li> <li>• IBM 32-bit Runtime Environment for Linux on Intel, iSeries, and pSeries architecture, Java 2 Technology Edition, <b>Version 5.0</b></li> <li>• The Apache Software License, <b>Version 1.1</b> and <b>Version 2.0</b></li> </ul> </li> </ol>	

---

## Notices

This information was developed for products and services offered in the U.S.A.

InfoPrint Solutions Company may not offer the products, services, or features discussed in this document in other countries. Consult your local InfoPrint Solutions Company representative for information on the products and services currently available in your area. Any reference to an InfoPrint Solutions Company product, program, or service is not intended to state or imply that *only* that InfoPrint Solutions Company product, program, or service may be used. Any functionally equivalent product, program, or service that does not infringe any InfoPrint Solutions Company intellectual property rights may be used instead. However, it is the user's responsibility to evaluate and verify the operation of any non-InfoPrint Solutions Company product, program, or service.

InfoPrint Solutions Company may have patents or pending patent applications covering subject matter described in this document. The furnishing of this document does not give you any license to these patents. You can send license inquiries, in writing, to:

InfoPrint Solutions Company, LLC  
6300 Diagonal Hwy 002J  
Boulder, CO 80301-9270  
U.S.A.

For license inquiries regarding double-byte (DBCS) information, contact the InfoPrint Solutions Company Intellectual Property Department in your country or send inquiries, in writing, to:

InfoPrint Solutions Company, LLC  
6300 Diagonal Hwy 002J  
Boulder, CO 80301-9270  
U.S.A.

**The following paragraph does not apply to the United Kingdom or any other country where such provisions are inconsistent with local law: INFOPRINT**

SOLUTIONS COMPANY PROVIDES THIS PUBLICATION "AS IS" WITHOUT WARRANTY OF ANY KIND, EITHER EXPRESS OR IMPLIED, INCLUDING, BUT NOT LIMITED TO, THE IMPLIED WARRANTIES OF NON-INFRINGEMENT, MERCHANTABILITY OR FITNESS FOR A PARTICULAR PURPOSE. Some states do not allow disclaimer of express or implied warranties in certain transactions, therefore, this statement may not apply to you.

This information could include technical inaccuracies or typographical errors. Changes are periodically made to the information herein; these changes will be incorporated in new editions of the publication. InfoPrint Solutions Company may make improvements and/or changes in the product(s) described in this publication at any time without notice.

Any references in this information to non-InfoPrint Solutions Company Web sites are provided for convenience only and do not in any manner serve as an endorsement of those Web sites. The materials at those Web sites are not part of the materials for this InfoPrint Solutions Company product and use of those Web sites is at your own risk.

InfoPrint Solutions Company may use or distribute any of the information you supply in any way it believes appropriate without incurring any obligation to you.

Licensees of this program who wish to have information about it for the purpose of enabling: (i) the exchange of information between independently created programs and other programs (including this one) and (ii) the mutual use of the information which has been exchanged, should contact:

InfoPrint Solutions Company, LLC  
6300 Diagonal Hwy 002J  
Boulder, CO 80301-9270  
U.S.A.

Such information may be available, subject to appropriate terms and conditions, including in some cases, payment of a fee.

The licensed program described in this document and all licensed material available for it are provided by InfoPrint Solutions Company under terms of the InfoPrint Solutions Company Customer Agreement, InfoPrint Solutions Company International Program License Agreement or any equivalent agreement between us.

Any performance data contained herein was determined in a controlled environment. Therefore, the results obtained in other operating environments may vary significantly. Some measurements may have been made on development-level systems and there is no guarantee that these measurements will be the same on generally available systems. Furthermore, some measurement may have been estimated through extrapolation. Actual results may vary. Users of this document should verify the applicable data for their specific environment.

Information concerning non-InfoPrint Solutions Company products was obtained from the suppliers of those products, their published announcements or other publicly available sources. InfoPrint Solutions Company has not tested those products and cannot confirm the accuracy of performance, compatibility or any other claims related to non-InfoPrint Solutions Company products. Questions on the capabilities of non-InfoPrint Solutions Company products should be addressed to the suppliers of those products.

All InfoPrint Solutions Company prices shown are InfoPrint Solutions Company's suggested retail prices, are current and are subject to change without notice. Dealer prices may vary.

This information contains examples of data and reports used in daily business operations. To illustrate them as completely as possible, the examples include the names of individuals, companies, brands, and products. All of these names are fictitious and any similarity to the names and addresses used by an actual business enterprise is entirely coincidental.

#### COPYRIGHT LICENSE:

This information contains sample application programs in source language, which illustrates programming techniques on various operating platforms. You may copy, modify, and distribute these sample programs in any form without payment to InfoPrint Solutions Company, for the purposes of developing, using, marketing or distributing application programs conforming to the application programming interface for the operating platform for which the sample programs are written. These examples have not been thoroughly tested under all conditions. InfoPrint Solutions Company, therefore, cannot guarantee or imply reliability, serviceability, or function of these programs.

If you are viewing this information softcopy, the photographs and color illustrations may not appear.

References in this document to InfoPrint Solutions Company products, product features, programs or services do not imply that InfoPrint Solutions Company intends to make such products, product features, programs or services available in all countries in which InfoPrint Solutions Company operates or does business.

## Trademarks

These terms are trademarks or registered trademarks of Ricoh Co., Ltd., in the United States, other countries, or both:

- Advanced Function Presentation
- AFP
- InfoPrint
- Infoprint
- Ricoh

These terms are trademarks or registered trademarks of International Business Machines Corporation in the United States, other countries, or both:

- AIX
- IBM
- xSeries
- z/OS

Adobe, the Adobe logo, PostScript, and the PostScript logo are either registered trademarks or trademarks of Adobe Systems Incorporated in the United States and/or other countries.

Intel, Intel Inside (logos), MMX, and Pentium are trademarks of Intel Corporation in the United States, other countries, or both.

Java and all Java-based trademarks are trademarks of Sun Microsystems, Inc. in the United States, other countries, or both.

Linux is a registered trademark of Linus Torvalds in the United States, other countries, or both.

Microsoft, Windows, Windows NT, and the Windows logo are trademarks of Microsoft Corporation in the United States, other countries, or both.

UNIX is a registered trademark of The Open Group in the United States and other countries.

Other company, product, or service names may be trademarks or service marks of others.



---

## Chapter 2. Installing InfoPrint Transform Manager for Linux

Before you can use Transform Manager, you need to install it to set up the Transform Manager User Interface.

You need to install Transform Manager on xSeries Servers or an IBM eServer BladeCenter. Next, you can log into Transform Manager and work with the Transform Manager User Interface.

**Note:** Service Pack 4, also called PTF U810977, was distributed as a complete Product Update with new CD-ROM numbers, which are used in the topics that describe installing InfoPrint Transform Manager for Linux.

---

### Installing the Transform Manager on xSeries servers using the InstallShield Wizard

Before you can use the Transform Manager, you need to install it on an xSeries server.

Make sure all required hardware and software is available (see “System requirements” on page 9 for information). If you are installing Transform Manager on an xSeries server that has InfoPrint ProcessDirector already installed on it, the job submission from InfoPrint ProcessDirector must be stopped before installing Transform Manager.

Use the following procedure to install the Transform Manager on a Linux workstation with the InstallShield Wizard. If you have problems installing with the InstallShield Wizard, see the release notes file on the product CD for information about installing from the Linux command line.

1. Log in as a root (administrator) user.
2. Insert the product CD (LCD4-5611-04) in the CD-ROM drive. Mount the CD if it does not mount automatically by specifying: `mount/media/cdrom`.
3. Select the **install.sh** file in the `/media/cdrom` directory. You see a product window with the copyright statement and then you see a welcome window.
4. Click **Next** on the Infoprint Transform Manager Welcome screen. You see a list of tasks.
5. Select **View the release notes** for information about installing the Transform Manager.
6. Select **Install InfoPrint Transform Manager** and then click **Next**. The InstallShield Wizard steps you through the installation.
7. When you see the license screens, select the button next to **I accept the terms of the license agreement** and click **Next**.
8. On the next screen, specify the number of compute nodes to be installed. The number of compute nodes must be at least two and it must be equal to the number of CPUs installed on the machine (reported by the installer). Any number of compute nodes between these two values is valid.
9. In the Installation summary information window, click **Install**.
10. When asked to enter an administrator password for Infoprint Transform Manager, enter a password and click **Next**.
11. Click **Finish**. The installation summary includes information about accessing the user interface with a Web browser.

When the installation is complete, you must configure one or more print servers to communicate with the Transform Manager.

**Keep in mind:** If you install multiple, separately licensed Transform Manager systems, you can use the user interface from any installation to add and manage the transform servers from the other installations.

---

## Installing the Transform Manager on xSeries servers from the command line

In addition to installing Transform Manager with the GUI, you can also install it from the command line.

Make sure all required hardware and software is available (see “System requirements” on page 9 for information). If you are installing Transform Manager on an xSeries server that has InfoPrint ProcessDirector already installed on it, the job submission from InfoPrint ProcessDirector must be stopped before installing Transform Manager.

Use the following procedures to install the Transform Manager on a Linux workstation from the command line.

1. Log in as a root (administrator) user.
2. Insert the product CD (LCD4-5611-04) in the CD-ROM drive.
3. Enter this command from the CD directory: `./install.sh -console`.
4. If you see a list of supported languages, do this:
  - a. Enter the option for the appropriate language. You see an **X** next to the selected language.
  - b. Enter **0**.
  - c. Enter **1** to continue.

You see welcome information for the installation.

5. Enter **1** to continue. You see a list of tasks.
6. Enter the option for **Install InfoPrint Transform Manager**. You see an **X** next to the selection.
7. Enter **0** and then enter **1**. You see the IBM license agreement.
8. Read the license agreement and then enter **1** to accept the agreement. You see an **X** next to the selection.
9. Enter **0** and then enter **1**.
10. You see a screen that asks you for the number of compute nodes (that you purchased) to be installed. This number has to be at least two and at most equal to the number of CPUs installed on the machine.
11. Read the summary information and then enter **1**. The installation begins and you see several bars that indicate the progress of the installation.
12. Enter **1** to continue. You see another progress bar.
13. When the installation completes successfully, you see the Web address for the Transform Manager user interface and directions for accessing the user interface on the Linux workstation.
14. Record the Web address and then bookmark it in the Web browser you are using to access the user interface. For information about using the user interface, refer to the online help and *InfoPrint Transform Manager for Linux: Installation and User's Guide*, G550-1048



15. Enter **1** to continue. You see a message.
16. If errors are listed in the message, contact Software Support for help.
17. Enter **3** to finish and exit from the installation program.
18. Eject the CD.
19. Log out as root and log in as another user.

---

## Installing InfoPrint Transform Manager on an IBM eServer BladeCenter

This topic describes the procedure for installing InfoPrint Transform Manager on an IBM eServer BladeCenter.

Before installing InfoPrint Transform Manager on an IBM eServer BladeCenter, you need to determine which blade will be the head node (the head node is the coordinating or arbitrating node), which blades will be the compute nodes (compute nodes transform the datastreams), and how many compute nodes you need. You must install the compute nodes before you install the head node.

You use Infoprint Transform Manager for Linux: Blade (CD1), LCD4-5614-02, for the compute nodes.

You use Infoprint Transform Manager for Linux: Blade (CD2), LCD4-5615-02, and Infoprint Transform Manager for Linux, LCD4-5611-04, for the head node.

## Installing a Transform Manager compute node on an IBM eServer BladeCenter

If you are installing Transform Manager on an IBM eServer BladeCenter that has InfoPrint ProcessDirector already installed on it, the job submission from InfoPrint ProcessDirector must be stopped before installing Transform Manager.

Use the following procedures to install a Transform Manager compute node on an IBM eServer BladeCenter with the InstallShield Wizard. The InstallShield Wizard steps you through the installation.

1. Log in as a root (administrator) user.
2. Insert the CD labeled Infoprint Transform Manager for Linux: Blade (CD 1), LCD4-5614-02, in the CD-ROM drive. When you insert the CD, it mounts automatically and displays the contents of the CD.
3. Launch `/media/cdrom/installnodes.sh` file.
4. On the Welcome screen, click **Next**.
5. The Select option windows displays the following choices: **View Release notes**, **Install IBM Infoprint Transform Manager** and **Contact us**. Select **Install IBM Infoprint Transform Manager** and click **Next**.
6. When you see the license screens, select the button next to **I accept the terms of the license agreement** and click **Next**.
7. When the installation summary display, click **Install**. At the end of the installation, a summary of the installation status displays.
8. Click **Finish**.
9. Repeat all steps for each compute node that you need.

## Installing an InfoPrint Transform Manager head node and user interface on an IBM eServer BladeCenter

If you are installing Transform Manager on an IBM eServer BladeCenter that has InfoPrint ProcessDirector already installed on it, the job submission from InfoPrint ProcessDirector must be stopped before installing Transform Manager.

Use the following procedures to install an InfoPrint Transform Manager head node and user interface on an IBM eServer BladeCenter with the InstallShield Wizard. The InstallShield Wizard steps you through the installation.

1. Log in as a root (administrator) user.
2. Insert the CD labeled InfoPrint Transform Manager for Linux: Blade (CD 2), LCD4-5615-02, in the CD-ROM drive. When you insert the CD, it mounts automatically and displays the contents of the CD.
3. Launch `/media/cdrom/installblades.sh` file.
4. On the Welcome screen, click **Next**.
5. The Select option windows displays the following choices: **View Release notes**, **Install IBM InfoPrint Transform Manager** and **Contact us**. Select **Install IBM InfoPrint Transform Manager** and click **Next**.
6. When you see the license screens, select the button next to **I accept the terms of the license agreement** and click **Next**.
7. When prompted by the InstallShield Wizard, insert the CD labeled InfoPrint Transform Manager, LCD4-5611-04, in the CD-ROM drive.
8. Enter the IP address or IP ranges for all the compute nodes. You see a Summary screen.
9. You see a screen that asks you for the number of compute nodes to be installed on each blade server. This number has to be at least two and at most equal to the number of CPUs installed on the machine. The screen lists the number of CPUs on each blade, and you must specify a number at least equal to 2 and at most equal to the number of CPUs on each blade. The total number of compute node for an InfoPrint Transform Manager installation must match the number of compute nodes that you purchased.
10. When the installation summary displays, click **Install**.
11. When prompted for the administrator password, enter a password, then enter the same password in the **Confirm password** field, and click **Next**.
12. At the end of the installation, a summary of the installation status displays.
13. Click **Finish**.

---

## Logging in to the Transform Manager

This topic describes how to log in to the Transform Manager.

To log in:

1. Bring up the Transform Manager user interface in a Web browser by entering this address: **`http://{target server host name or ip address}:{port determined at install}/psd`**. The default port number is 14080. If Transform Manager is installed on a host with this TCP/IP address **127.0.0.1** with the default port, the address to access the user interface would be: **`http://127.0.0.1:14080/psd`**. In the browser window, you see the **Log in to Transform Manager** page.
2. Type the Transform Manager password.

3. Select **Log in**. You see the Transform Manager main page.

**Remember:** If you do not use the Transform Manager for 30 minutes or more, you must log in again.

When you first log in to the Transform Manager, you see one transform server that has been added by default during the installation.



---

## Chapter 3. Configuring InfoPrint Transform Manager

Before you can use InfoPrint Transform Manager, you need to add a Transform Server and the appropriate print servers.

You might also want to specify a unique password instead of using the default **nopassword**.

Depending on which print servers you use, there are unique configuration tasks to be completed as well, such as authorizing a User ID for use with Infoprint Manager.

---

### Changing passwords

If you want to change the password for Transform Manager, you need to know the current password.

To change the password that is used to authenticate any user who tries to log in to the Transform Manager user interface:

1. Click **Preferences** in the Banner area on the Transform Manager main page. This opens the **Change Login Password** screen.
2. Type your current password in the **Current password** entry field.
3. Type a new password in the **New password** entry field. Passwords can only be alphanumeric characters (a-z A-Z 0-9) and the special characters (! @ # \$ % ^ & \* ( ) ) on the keyboard accessed by pressing the shift key for the numbers 0-9. Passwords are limited to 128 characters. Zero-length passwords are allowed. The default password is an empty string, which means you do not need to specify a password.
4. Type the new password again in the **Confirm the new password** entry field. The password you type here must match the new password you typed in the **New password** entry field. The password automatically takes effect the next time you log in to the Transform Manager user interface.
5. Click **Change** to change the password. This message is displayed on the Transform Manager main page: The Login password was changed successfully.

---

### Adding a transform server

Before you can add a transform server, you need to determine the host name or IP address for the transform server and the port number to use for the transform server. You can use the default port number.

To add a transform server:

1. On the *Transform Manager* page, select **Add...** for the transform server action. You see the *Add Transform Server* page.
2. Type the host name or IP address for the transform server.
3. Use the default port number or type another port number for the transform server.
4. Select **OK**. You see a message in the message box and then you see the *Transform Manager* page. When the add action is complete, you see the transform server in the list.

---

## Adding a print server

Before you can add a print server, you need to determine the host name or IP address for the print server and the port number to use for the print server. You can use the default port number.

To add a print server:

1. On the *Transform Manager* page, select **Add...** for the print server action. You see the *Add Print Server* page.
2. Select the appropriate server type from the **Server Type** pull-down list.
3. When you select one of the Infoprint Manager choices, complete these steps:
  - a. Type the server name for the print server.
  - b. Type the host name or IP address for the print server.
  - c. Use the default port number or type another port number for the print server.
4. When you select InfoPrint ProcessDirector or z/OS Server, type the host name or IP address for the print server.
5. Select **OK**. You see a message in the message box and then you see the *Transform Manager* page. When the add action is complete, you see the print server in the list.

---

## Configuring InfoPrint Manager for AIX and Windows for use with Transform Manager

In order for a print server to send transform requests to the Transform Manager, you must authorize the Transform Manager User ID and configure the print server to communicate with the Transform Manager.

To configure InfoPrint Manager for AIX and Windows for use with Transform Manager, complete these tasks:

- Authorize the Transform Manager User ID
- Add InfoPrint Manager as a print server to the Transform Manager, which results in changes in InfoPrint Manager.
- Test the resulting print server configuration.

## Authorizing the Transform Manager user ID

During the Transform Manager installation, a user ID, **ibmitm**, is created on the Linux workstation. The Transform Manager uses this user ID to access print servers. You must configure InfoPrint Manager to authorize this Transform Manager user ID with administrator access to the print server. The way you authorize access in InfoPrint Manager depends on the operating system you are using:

- If you are using InfoPrint Manager for AIX without DCE:
  1. Access the System Management Interface Tool (SMIT).
  2. Select **InfoPrint Printing System-->Security-->Groups-->Add User to Group**.
  3. Add **ibmitm@workstation** to the **admin** group, where *workstation* is either the fully-qualified host name or IP address of the Transform Manager workstation (such as: mytm1.boulder.ibm.com or 195.168.1.242) or the wildcard character (\*) that represents any Transform Manager workstation.

To learn more about authorizing access in InfoPrint Manager for AIX, refer to managing non-DCE security in *InfoPrint Manager for AIX: Procedures*, G544-5815.

- If you are using InfoPrint Manager for AIX with DCE:

You need to manually set the **transform-manager-host** and **transform-manager-port** attributes on the Infoprint Manager Server with the **pdset** command. For example, if **itm** is the name of the system running Infoprint Transform Manager and **ipm4aix** is the name of the Infoprint Manager Server, type:

```
pdset -c server -x "transform-manager-host=itm" ipm4aix
pdset -c server -x "transform-manager-port=6986" ipm4aix
```

- If you are using InfoPrint Manager for Windows:

1. Access the InfoPrint Manager Management Console.
2. Select **Security-->Groups**.
3. Add **ibmitm@workstation** to the **admin** group, where *workstation* is either the fully-qualified host name or IP address of the Transform Manager workstation (such as: mytm1.boulder.ibm.com or 195.168.1.242) or the wildcard character (\*) that represents any Transform Manager workstation.
4. From Transform Manager, be sure to specify the server name in case-sensitive form.

To learn more about authorizing access in InfoPrint Manager for Windows, refer to managing security in *InfoPrint Manager for Windows: Procedures*, G544-5814.

## Adding the print server for InfoPrint Manager

In order for the Transform Manager to transform InfoPrint Manager print jobs, you must add the print server with the Transform Manager user interface. Adding a print server in the Transform Manager sets these two attributes in InfoPrint Manager:

**transform-manager-host**  
**transform-manager-port**

When you define the print server, the **transform-manager-host** attribute is set to the Transform Manager host name or IP address and the **transform-manager-port** attribute is set to the default Transform Manager port, which is 6986. You must add a print server for each InfoPrint Manager server you want to use. If these attributes are not set, the transforms in the InfoPrint Manager print server are used.

**Note:** Do not set these attributes when you submit a print request. If you specify these attributes in InfoPrint Manager on the job request instead of adding the print server in the Transform Manager, the print server is not displayed in the list of print servers on the Transform Manager user interface page.

### Related tasks

“Adding a print server” on page 22

## Testing the InfoPrint Manager print server configuration

After you have added a print server for use with InfoPrint Manager, you need to test the print server configuration.

To test the print server configuration for InfoPrint Manager with Transform Manager:

1. Submit a non-AFP print job to the print server and view the status of the transform request on the Transform Manager main page to verify that you configured the print server correctly. You might need to watch closely in case the processing happens quickly.
2. To check that your job was transformed successfully from the Transform Manager user interface, click on the **Actions** pull-down list of the Transform Server main page to display the Job Log for the transform server you are working with. Look for the entry that contains your test job's name.

#### **Related tasks**

“Adding a print server” on page 22

---

## **Configuring InfoPrint ProcessDirector for use with Transform Manager**

In order for InfoPrint ProcessDirector to send transform requests to the Transform Manager, you need to configure a print server and customize InfoPrint ProcessDirector.

To configure InfoPrint ProcessDirector for use with Transform Manager, use these procedures to:

- Add InfoPrint ProcessDirector as a print server to the Transform Manager.
- Test the resulting print server configuration.

For more information about the steps you do on InfoPrint ProcessDirector, see InfoPrint ProcessDirector online help.

**Note:** If you use the Firefox Web browser with InfoPrint ProcessDirector, you will be asked to log in whenever you switch between the Transform Manager GUI and the InfoPrint ProcessDirector GUI and want to perform an action. This does not occur with Microsoft Internet Explorer.

### **Adding a print server for InfoPrint ProcessDirector**

To configure InfoPrint ProcessDirector with Transform Manager, you need to add a print server for InfoPrint ProcessDirector's use.

Once you have added the print server for InfoPrint ProcessDirector and identified the Transform Server that you will use, you need to configure Transform Manager within InfoPrint ProcessDirector. Record the Transform Server IP address or DNS name and the Transform Server port number, so that you have it available when you configure InfoPrint ProcessDirector to send jobs to Transform Manager.

For more information about the steps you do on InfoPrint ProcessDirector, see InfoPrint ProcessDirector online help.

#### **Related tasks**

“Adding a print server” on page 22

### **Testing the InfoPrint ProcessDirector print server configuration**

This topic describes how to test the InfoPrint ProcessDirector print server configuration for Transform Manager.

To test the print server configuration:

1. On the InfoPrint ProcessDirector system, submit a request to transform a non-AFP document to AFP format.
2. Check the AFP output.



3. Review Transform Manager Server job log by selecting **Actions** and then clicking **View Job Log**.

---

## Configuring Infoprint Server for z/OS for use with Transform Manager

This topic describes how to configure your system to use Infoprint Server for z/OS as a print server for transform output.

In order for Infoprint Server for z/OS to send transform requests to the Transform Manager, you need to configure a print server. Use these procedures to:

- Add Infoprint Server for z/OS as a print server to the Transform Manager.
- Customize Infoprint Server for z/OS to use the Transform Manager.
- Test the resulting print server configuration.

For more information about the steps you do on the z/OS system, see the Infoprint Server for z/OS documentation.

### Related tasks

“Adding a print server” on page 22

## Customizing Infoprint Server for z/OS for use with Transform Manager

This topic describes how to customize the Infoprint Server for z/OS so that it can do transforms on the Linux system when requested.

1. In the remote transform configuration file, **aoprxf.conf**, provide the host name or IP address and the port number of the Linux system.
2. In the Infoprint Server for z/OS Printer Inventory, customize the PSF printer definitions to do transforms to AFP on the Linux system.

## Testing the Infoprint Server for z/OS print server configuration

This topic describes how to test the Infoprint Server for z/OS print server configuration for Transform Manager.

To test the print server configuration:

1. On the z/OS system, submit a request to transform a non-AFP document to AFP format.
2. Check the AFP output.
3. Review Transform Manager Server job log by selecting **Actions** and then clicking **View Job Log**.



---

## Chapter 4. Working with transform servers

Once you have installed and configured Transform Manager, tasks that apply to transform servers can be completed within the Transform Manager User Interface.

Starting from the Transform Manager main page, you can complete these tasks for a transform server:

- Log in to Transform Manager
- Start a transform server.
- Stop a transform server.
- Add a transform server.
- Remove a transform server.
- Display job information about a transform server.
- Change information for a transform server.
- Resetting transform manager.
- Manage print servers.
- Use Transform Manager file directories.

**Note:** Adding additional transform servers might require configuration. Therefore, the information about adding a transform server is included with the configuration information. See “Adding a transform server” on page 21.

---

### Logging in to the Transform Manager

This topic describes how to log in to the Transform Manager.

To log in:

1. Bring up the Transform Manager user interface in a Web browser by entering this address: **http://{target server host name or ip address}:{port determined at install}/psd**. The default port number is 14080. If Transform Manager is installed on a host with this TCP/IP address **127.0.0.1** with the default port, the address to access the user interface would be: **http://127.0.0.1:14080/psd**. In the browser window, you see the **Log in to Transform Manager** page.
2. Type the Transform Manager password.
3. Select **Log in**. You see the Transform Manager main page.

**Remember:** If you do not use the Transform Manager for 30 minutes or more, you must log in again.

When you first log in to the Transform Manager, you see one transform server that has been added by default during the installation.

---

### Starting transform servers

To start transform servers:

1. On the *Transform Manager* main page, check one or more transform servers in the Transform Server Select column.
2. Select **Start** for the selected transform servers. When a transform server's state is **Ready** or **Transforming**, it is ready to accept a transform request.

---

## Stopping transform servers

To stop transform servers:

1. On the *Transform Manager* main page, check one or more transform servers in the Transform Server Select column.
2. Select **Stop** for the selected transform servers. These transform servers complete any transform requests in progress and do not accept any more requests.

---

## Removing transform servers

To remove transform servers from the Transform Manager:

1. On the *Transform Manager* main page, check one or more transform servers in the Transform Server Select column.
2. Select **Remove** for the selected transform servers. You see the *Confirm Removal of Transform Servers* page.
3. Select **Yes**. You see a message in the message box and then you see the *Transform Manager* page. When the remove action is complete, you see the list without the selected transform servers.

---

## Displaying job information for a transform server

To view the job information for a transform server:

1. On the Transform Manager main page, click **Actions**. You see two choices: **View Log** and **View History** in the drop-down menu.
2. Select **View Log**. The **Job Log for Transform Server: *n.nn.nnn.nnn*** opens, where *n.nn.nnn.nnn* is the transform server you selected on the Transform Manager main page.
3. Select **View History**. The **Job History for Transform Server: *n.nn.nnn.nnn*** opens, where *n.nn.nnn.nnn* is the transform server you selected on the Transform Manager main page.

---

## Displaying specific messages for a transform server

To display specific messages:

1. On the Job Log for the transform server, select or enter data for one or more of the criteria fields. With the **Issued within:** field, you can specify the messages to include for **1-7** days or specify **All** to specify all messages, or you can specify the messages to include for **1-24** hours or specify **All** to specify all messages. Paging controls appear at the bottom of the Job Log. You can use these controls to move forward, backward, and jump to a specific page of the log. You can also specify the number of entries shown in the log by changing the number in **Display**.
2. Select **Refresh**. The list of messages is updated based on the criteria you selected.
3. Select **Export**. When you select the **Export** button, a message is issued stating that the export might take time to process. Next, the system **Export Log** dialog appears where you can save the log to disk.
4. Click **OK** after entering the location where you want to save the log.
5. Select **Close**. You see the *Transform Manager* page.

When you install PTF U810978, you can click the **Export Traces** button on the Transform Manager main page to export the logs for a selected server.

---

## Displaying specific job history for a transform server

To display specific job history:

1. On the Job History for the transform server, select or enter data for the **Started within:** criteria field. You can specify the messages to include for **1-7** days or specify **All** to specify all messages, or you can specify the messages to include for **1-24** hours or specify **All** to specify all messages. The **Job ID** field contains a number that Transform Manager generates and is only relevant to Transform Manager. This **Job ID** number does not start at **1** and might not be consecutive.
2. Select **Refresh**. The list of messages is updated based on the criteria you selected.
3. Select **Export**. The system **Export History** dialog appears where you can save the history to disk.
4. Click **OK** after entering the location where you want to save the log.
5. If you want to clear the history, select **Clear**. The **Clear jobs history** message appears.
6. When the **Clear jobs history** message appears, click **OK** to clear the message or click **Cancel** to return to the job history page.
7. Select **Close**. You see the *Transform Manager* page.

**Note:** Paging controls appear at the bottom of the Job History. You can use these controls to move forward, backward, and jump to a specific page of the log. You can also specify the number of entries shown in the log by changing the number in **Display**.

---

## Changing transform server information

You use the Properties Pages to change the information for a transform server.

To access the Properties Pages for a specific transform server:

1. Click the hyperlink for the specific transform server on the Transform Manager main page. The **Properties Page for Transform Server: *n.nn.nnn.nnn*** opens, where *n.nn.nnn.nnn* is the Host Name or TCP/IP address of a Transform Server you selected.

Properties are grouped on three tabs: General, Status, and Trace. You can view all of the properties at once by clicking **Show all tabs** in the left pane.

2. You can change any of the information on these pages that has an entry field.
3. Click the **?** button next to each entry field for information about it.
4. Click **OK** to save any changed properties and return to the Transform Manager main page.

---

## Resetting Transform Manager

You use the **Reset ITM** button on the Transform Manager main page to reset the selected Transform Manager.

1. Click the **Reset ITM** button. This opens the **Reset Transform Manager** screen.
2. Type the root password for the machine where Transform Manager is installed.
3. Click the **Reset ITM** button on the **Reset Transform Manager** screen.

## Reset Transform Manager

You use the **Reset Transform Manager** screen to reset Transform Manager.

Specify the root password for the machine where Transform Manager is installed.

### Reset password

This box is used to specify the root password for the machine where the Transform Manager is installed.

---

## Managing transform servers

To manage transform servers, do this on the *Transform Manager* main page:

1. To start, stop, add, or remove transform servers, check one or more transform servers in the Transform Server Select column. With PTF U810978, you can also export logs about one or more transform servers that you have selected.
2. Select one of these actions:

Action	Description
<b>Start</b>	Initialize the selected transform servers so they can start accepting new transform requests.
<b>Stop</b>	Let the selected transform servers complete processing current requests and then become unavailable to accept new transform requests.
<b>Add</b>	Define a new transform server to the Transform Manager.
<b>Remove</b>	Remove the selected transform servers from the Transform Manager.
<b>Export Traces</b>	Capture the traces for the selected transform servers, pack them, and save them on your local computer.

If you select the Add action, you see the *Add Transform Server* page. If you select the Remove action, you see the *Confirm Removal of Transform Servers* page. Otherwise, the Transform Manager performs the action and a message box indicates the status of the action.

---

## Understanding file directories

This topic describes the directories containing the Transform Manager files.

The Transform Manager is installed on the Linux workstation in these directories:

### Transform Manager persistent data

/opt/IBM/itm

### Transform Manager workspace data

/var/IBM/itm

### Transform Manager user interface

/opt/IBM/itm/ejz

---

## Chapter 5. Working with print servers

Once you have installed and configured Transform Manager, tasks that apply to print servers can be completed within the Transform Manager User Interface.

Starting from the Transform Manager main page, you can complete these tasks for a print server:

- Add a print server.
- Reconnect a print server.
- Remove print servers.
- Change a print server.
- Managing print servers.

**Note:** Because you need to add a print server when you are configuring Transform Manager, the information about adding a print server is included with the configuration information. See “Adding a print server” on page 22.

---

### Reconnecting print servers

To reconnect a print server with the Transform Manager:

1. On the Transform Manager main page, check one or more print servers in the Print Server Select column.
2. Select **Reconnect** for the print server action.
3. You see a message in the message box and then you see the Transform Manager page. When the reconnect action is complete, you see a message indicating the success of the operation.

When you reconnect a print server, Transform Manager re-registers with that print server. This makes sure that all subsequent jobs submitted from that print server are processed by the Transform Manager. This operation is useful if, for example, after the print server was added to the Transform Manager, the values of the **transform-manager-host** and **transform-manager-port** attributes were changed accidentally.

---

### Removing print servers

To remove print servers from the Transform Manager:

1. On the Transform Manager main page, check one or more print servers in the Print Server Select column.
2. Select **Remove** for the print server action. You see the *Confirm Removal of Print Servers* page.
3. Select **Yes**. You see a message in the message box and then you see the Transform Manager page. When the remove action is complete, you see the list without the selected print servers.

When you remove an InfoPrint Manager print server, Transform Manager reconfigures InfoPrint Manager to stop sending transform jobs to Transform Manager. When you remove an Infoprint Server or an InfoPrint ProcessDirector print server, Transform Manager removes the print server from the list of print servers.

---

## Changing print server definitions

To change the definitions for a print server, you cannot edit the existing print server definition. You must first remove the print server from the Transform Manager and then add the print server to the Transform Manager with a new definition.

1. “Removing print servers” on page 31.
2. Add a print server.

---

## Managing print servers

To manage print servers, do this on the *Transform Manager* page:

1. Check one or more print servers in the Print Server Select column.
2. Select one of these actions:

Action	Description
<b>Add</b>	Define a new print server to the Transform Manager.
<b>Reconnect</b>	Reconnect a print server to the Transform Manager.
<b>Remove</b>	Remove the selected print servers from the Transform Manager.

If you select the Add action, you see the *Add Print Server* page. If you select the Remove action, you see the *Confirm Removal of Print Servers* page.

### Related tasks

- Adding a print server
- Changing print server definitions
- “Reconnecting print servers” on page 31
- Removing print servers



---

## Chapter 6. Working with resources

The **Resources distributor** screen is used to copy resources within the directory structure of Transform Manager.

You can copy a single resource file or an archive of multiple resource files. The resources are copied on all selected Transform Servers with one request.

---

### Resources distributor

The **Resources distributor** screen is used to copy resources within the directory structure of Transform Manager. You can copy a single resource or an archive of multiple resources.

#### Transform Servers

This box lists the Transform Servers where the resources will be copied. This is an informational field that you cannot make changes to.

Use the slider on the right side of the box to move the contents up and down.

#### Transforms

This box lists the transforms that you can copy resources for.

When you select a transform, the contents of the **Resources Type** field changes.

Use the slider on the right side of the box to move the contents up and down.

#### Resources Type

This box lists the resources types for the selected transform.

Select the resource type that matches the file to be copied.

Use the slider on the right side of the box to move the contents up and down.

#### Resources File

This field lists the file to be copied that you select with the **Browse...** button.

Click the **Browse...** button to select the file to be copied.

The file can be a single resource file or an archive file with a file type of `tgz` or `zip`.

#### Archive

This box is used to specify if the file to be copied is an archive file.

From the pull-down list, click **Yes** if you are copying an archive file or click **No** if you are copying a single resource file.

Transform Manager unpacks the archive file and copies the contents to the selected transform's resources directory. A single resource file is copied to the selected transform's resource directory.

## Existing Files

This box lists what action to take when a resource file already exists on a machine.

Select an action from the pull-down list:

**Fail** Before copying any files, Transform Manager checks to see if any files would get overwritten by the copy process. When **Fail** is selected, resource copying ends and message EJZ00228E displays.

**Skip** A resource file is copied only if it does not already exist.

### Overwrite

A resource file is copied and overwrites a file with the same name if it already exists.

---

## Copying resources

You use the **Resource distributor** screen to copy resources across the Transform Manager compute nodes.

If you want to move more than one resource at a time, use the packaging scripts to create an archive of resources. The **Resource distributor** treats an archive of files as a single file.

To copy resources to the Transform Manager compute nodes:

1. From the main Transform Manager page, select the Transform Servers where the resource will be copied.
2. Select **Distribute resources** from the **Actions** pull-down list. The **Resource distributor** screen displays.
3. Click **Browse** next to the **Resources file** entry.
4. Select a resource file or an archive file containing resource files to copy to all compute nodes on your Transform Servers.

---

## Resource packaging scripts

Transform Manager includes packaging scripts for the AIX, Linux, Windows, and z/OS operating systems.

The **Resource distributor** within the Transform Manager graphical user interface can only copy one resource object at a time because of browser restrictions. Therefore, Transform Manager includes packaging scripts so that you can create archive files for multiple resource objects. An archive file is treated as a single object with the **Resource distributor**. When you are using an archive file to distribute resource objects, you must specify **Yes** from the **Archive** pull-down list.

Transform Manager has a unique script for each operating system called `respack`. You can distinguish between the operating systems by the directory that contains the script. This is the directory structure and name for the supported operating systems:

**AIX** `/tools/respack/aix/respack.sh`

**Linux** `/tools/respack/linux/respack.sh`

### Windows

`/tools/respack/windows/respack.bat`

**z/OS** /tools/respack/zos/respack.sh

The scripts can be found on the Product CD-ROM and the Blade CD-ROM. You can also find the script on the machine where Transform Manager is installed in the /opt/IBM/itm/tools/respack. Make sure to transfer the scripts in binary mode to the machine where they will be run.

The syntax for all the scripts is:

```
<script_name> <archive_name> <source_dir>
```

Where:

*<script\_name>*

The name of the script.

*<archive\_name>*

The name of the archive where the resources are packed.

*<source\_dir>*

The name of the directory where the resources are located.

The **Resource distributor** unpacks the resources in their respective locations in the Transform Manager directory structure, regardless of their relative paths in the archive file.



---

## Chapter 7. Updating InfoPrint Transform Manager with Service Packs

When Service Packs, which are also called PTFs, are released for InfoPrint Transform Manager, you need to access the code to update the base product.

Service Packs contain new function and program fixes that will enhance your experience with the product. For example, Service Pack 2 contains a revised user interface that simplifies your interaction with Transform Manager.

You can access the code in two ways:

- Go out to the Web site for the Service Pack, create a CD of the code as instructed, and then install the code from the CD you created.
- Obtain a Service CD from your representative and install it.

---

### Updating Transform Manager from the Web site

When a Service Pack is made available for Transform Manager, you need to determine the FTP Web site where the Service Pack is available for downloading.

These Service Packs are available for Transform Manager:

- Service Pack 1, also called PTF U806504, is located at <http://www-1.ibm.com/support/docview.wss?uid=psd1P4000470>
- Service Pack 2, also called PTF U809395, is located at <http://www-1.ibm.com/support/docview.wss?uid=psd1P4000495>
- Service Pack 3, also called PTF U809897, is located at <http://www-1.ibm.com/support/docview.wss?uid=psd1P4000516>
- Service Pack 4, also called PTF U810977, was distributed as a complete Product Update with new CD-ROMs. Contact software support to obtain the new CD-ROMs.
- Service Pack 5, also called PTF U810978, is located at <http://www-1.ibm.com/support/docview.wss?uid=psd1P4000647>

#### Notes:

1. You can not install a Service Pack unless you have already installed the base code for Transform Manager.
2. Service Packs are cumulative. Therefore, after you have installed the base code, you only need to install the most recent service pack, that is Service Pack 5.

To update Transform Manager with a Service Pack from one of the Web Sites, also called a PTF or SP, complete these steps:

1. Access the appropriate Web Site. The appropriate download page opens. For example, InfoPrint Transform Manager for Linux PTF U810978.
2. Follow the download instructions on the page for the format of the Transform Manager server and the Transform Manager blade code.

---

### Updating Transform Manager from a service CD-ROM with InstallShield

When a Service Pack is made available for Transform Manager, you can obtain a service CD-ROM from your IBM representative.

**Note:** You can not install a Service Pack unless you have already installed the base code for Transform Manager.

To update Transform Manager with a Service Pack on a CD-ROM, also called a PTF or SP, complete these steps:

1. Log in as a root (administrator) user.
2. Insert the service CD in the CD-ROM drive. Mount the CD if it does not mount automatically by specifying: `mount/media/cdrom`.
3. Select the **install\_sp.sh** file in the `/media/cdrom` directory. You see a product window with the copyright statement and then you see a welcome window.
4. Click **Next** on the InfoPrint Transform Manager Welcome screen. You see a list of tasks.
5. Select the appropriate Service pack, such as **Install InfoPrint Transform Manager V1.2 Service Pack 5**, and then click **Next**. The InstallShield Wizard steps you through the installation.
6. When you see the license screens, select the button next to **I accept the terms of the license agreement** and click **Next**.
7. In the Installation summary information window, click **Install**. The default value is the number of compute nodes that are currently configured for use with InfoPrint Transform Manager
8. Click **Finish**. The installation summary includes information about accessing the user interface with a Web browser.

---

## Updating Transform Manager with a service CD-ROM from the command line

When a Service Pack is made available for Transform Manager, you can obtain a service CD-ROM from your software representative.

**Note:** You can not install a Service Pack unless you have already installed the base code for Transform Manager.

Use the following procedures to install the service CD-ROM for Transform Manager on a Linux workstation from the command line.

1. Log in as a root (administrator) user.
2. Insert the service CD-ROM in the CD-ROM drive.
3. Enter this command from the `/media/cdrom` directory: `./install_sp.sh -console`
4. Select from the following options:
  - a. Type **2** if you want to read the Contact information and press Enter.
    - 1) Type **0** and press Enter when finished.
    - 2) Type **1** and press Enter for the next dialog.
    - 3) Type **2** and press Enter for the previous dialog.
  - b. Type **1** if you want to continue with the installation and press Enter.
    - 1) Type **0** and press Enter when finished.
    - 2) Type **1** and press Enter for the next dialog.
5. Select the appropriate Service pack, such as **Install InfoPrint Transform Manager V1.2 Service Pack 5**, and then click **Next**. The InstallShield Wizard steps you through the installation.
6. Press Enter for the next page from the License Agreement.
7. Read the license agreement and then type **q** to continue.

- | 8. Enter **1** to accept the terms of the License Agreement.
- | 9. Enter **0** and press Enter when finished. The default value is the number of compute nodes that are currently configured for use with ITM.
- | 10. Enter **1** . Read the summary information and then type **1**.





---

## Chapter 8. Uninstalling InfoPrint Transform Manager

When you want to uninstall InfoPrint Transform Manager, you need to uninstall it from the xSeries server, the eServer BladeCenter, and the Linux server, as appropriate.

---

### Uninstalling Transform Manager from an IBM xSeries server

This topic describes the procedure for uninstalling InfoPrint Transform Manager from an IBM xSeries server.

Use this procedure to uninstall InfoPrint Transform Manager from an IBM xSeries server.

1. Go to the **Start** menu, select **InfoPrint Transform Manager**, and then select **Uninstall Transform Manager**. You see the Welcome to the uninstall program screen.
2. Click **Next**. You see the Summary Screen stating that the InstallShield Wizard will uninstall InfoPrint Transform Manager.
3. Click **Uninstall**. You see the screen stating that InfoPrint Transform Manager has successfully uninstalled.
4. Click **Finish** to exit the wizard.

---

### Uninstalling Infoprint Transform Manager from an IBM eServer BladeCenter

This topic describes how to uninstall Infoprint Transform Manager from the head node on an IBM eServer BladeCenter.

Use this procedure from the blade that is acting as the head node.

When Infoprint Transform Manager is uninstalled from the head node, it is also automatically uninstalled from the compute nodes.

1. Go to the **Start** menu, select **Infoprint Transform Manager**, and then select **Uninstall Transform Manager**. You see the Welcome to the uninstall program screen.
2. Click **Next**. You see the Summary Screen stating that the InstallShield Wizard has successfully uninstalled Infoprint Transform Manager.
3. Click **Uninstall**. You see the screen stating that Infoprint Transform Manager has successfully uninstalled.
4. Click **Finish** to exit the wizard.

---

### Uninstalling Transform Manager from the Linux command line

If you need to uninstall Transform Manager from the Linux command line, use this procedure.

1. Log in as a root (administrator) user.
2. Enter this command for a console uninstall:  
`/opt/IBM/itm/_uninst/uninst_lchr.sh -console`
3. Enter this command for a silent uninstall:  
`/opt/IBM/itm/_uninst/uninst_lchr.sh -silent` The silent uninstall does not produce any output and does not require user input.



---

## Chapter 9. Troubleshooting Transform Manager

As you use Transform Manager, you might need to diagnose error messages or work with Software Support to request trace information.

Transform Manager issues error messages as you work with the product. The location of these messages varies according to which print server is being used for transforms.

If you have determined that there is a problem based on error messages that have been issued, you might need to work with Software Support to request a trace of your Transform Manager system.

---

### Troubleshooting with InfoPrint Manager

Errors encountered when the Transform Manager is processing transform requests from InfoPrint Manager are logged in the Transform Server Job Log or the InfoPrint Manager error log. To access the Transform Manager Job Log, see “Displaying job information for a transform server” on page 28

**Related reference**

“Transform Manager messages” on page 121  
This section lists the Transform Manager messages.

---

### Troubleshooting with InfoPrint ProcessDirector

Linux end users can see transform error messages. Diagnosticians can find transform error messages in the Linux system log and in the Transform Manager Transform Server log.

**Related reference**

“Transform Manager messages” on page 121  
This section lists the Transform Manager messages.

---

### Troubleshooting with Infoprint Server for z/OS

z/OS end users can see transform error messages on a trailer page that Infoprint Server for z/OS adds to the document as an option. Diagnosticians can find transform error messages in the z/OS system log and in the Transform Manager Transform server log.

**Related reference**

“Transform Manager messages” on page 121  
This section lists the Transform Manager messages.

---

### Configuring a trace for a transform server

The Properties Page for Transform Server Trace page lets you enable or disable tracing for the specified transform server. You only use this page when Software Support asks you to run a trace to help diagnose a problem.

To configure a trace:

1. Click the hyperlink for the specific transform server that you want to trace on the Transform Manager main page. The **Properties Page for Transform Server: *n.nn.nnn.nnn*** opens, where *n.nn.nnn.nnn* is the TCP/IP address for the transform server you selected.

Properties are grouped on three tabs: General, Status, and Trace. You can view all of the properties at once by clicking **Show all tabs** in the left pane.

2. Click **Trace** to open the Trace page for the selected server.
3. On the Trace page, select the **Enabled** or **Disabled** from the **Tracing** drop-down menu. **Enabled** activates tracing, and **Disabled** deactivates tracing. The default is **Enabled**.
4. If tracing is **Enabled**, you can::
  - Check one or more of the choices in the **Trace Settings** list box.
  - Enter a custom trace setting as directed by Software Support.
5. Select **OK**. You see a message in the message box and then you see the *Transform Manager* page.

Click the **?** button next to each entry field for information about it.

---

## Chapter 10. Reference information for Transform Manager

As you use Transform Manager, you might want to refer to the details about the transforms it contains, usage notes, and messages.

Reference information that supports Transform Manager includes:

- Transforms available with Transform Manager
- Guidelines for reading the syntax diagrams
- Usage notes for the print servers
- Messages issued by Transform Manager
- Transform IDs used by Transform Manager

---

### Using the transforms

This section describes the transforms and the possible options and values that Transform Manager uses:

- GIF to AFP transform
- JPEG to AFP transform
- PCL to AFP transform
- PDF to AFP and PostScript to AFP transforms
- “Transform SAP OTF or ABAP data to AFP” on page 91
- TIFF to AFP transform

**Note:** When the Infoprint Transform Manager: *afp2pdf* Transform i-listed PRPQ, Program Number 5799-TWL, is purchased, Transform Manager supports the transform of AFP data to PDF data. For information about the **afp2pdf** transform, see *Infoprint Transform Manager: afp2pdf Transform Installation and User's Guide*, G550-0538.

Infoprint Manager for AIX and Windows or Infoprint Server for z/OS users can specify the transform options when they submit transform jobs and print jobs. For a description of exceptions or additional options and values that are available when using Infoprint Manager for AIX and Windows or Infoprint Server for z/OS, see the publications for these products.

### Transform GIF data to AFP

This section describes the **GIF to AFP** transform and includes its syntax and options and values.

#### Syntax

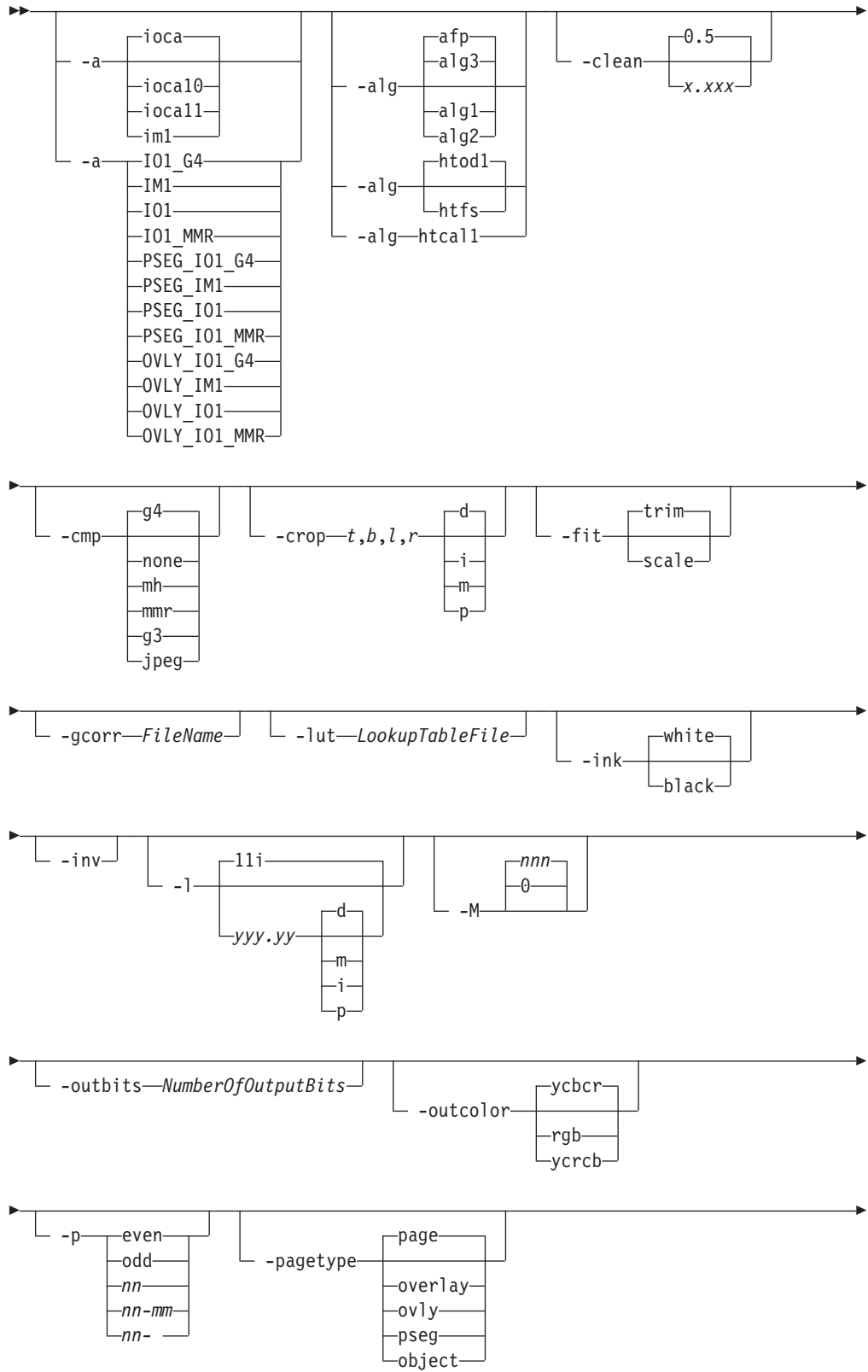

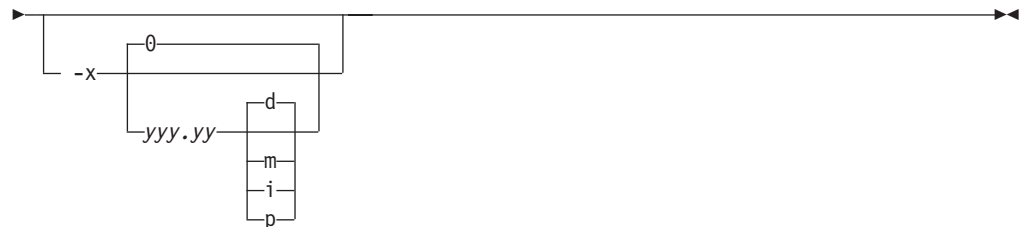
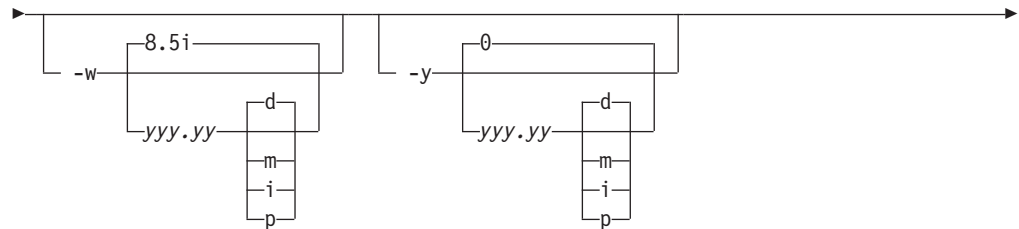
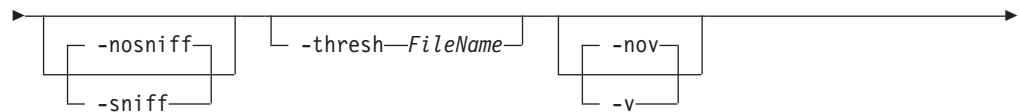
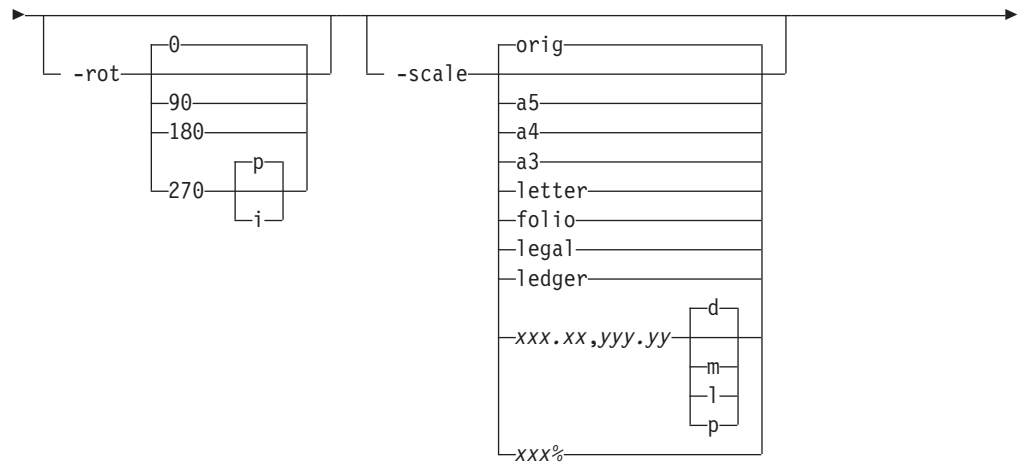
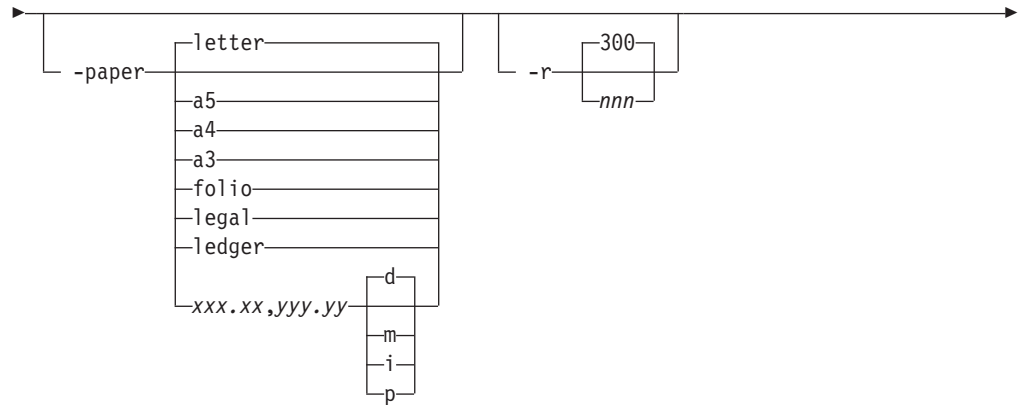

## Description

Use the **GIF to AFP** transform to transform a GIF (Graphical Interchange Format) data stream into an AFP (MO:DCA-P).

The transform can process GIF images, including bilevel, gray scale, and color images. The output can be bilevel (IM1 or IOCA FS10), 4-bit or 8-bit grayscale, or 24-bit YCbCr color (IOCA FS11). The transform automatically uses halftoning to convert the grayscale and color images to bilevel.

## Data transformations

If the input image is gray scale or color, and the output image type is bi-level (IOCA FS10 or IM1), the transform internally scales the image to the desired size, then uses a halftoning algorithm (ordered dither, the default, or Floyd-Steinberg) to convert it to bi-level. In converting the image to bi-level, the characteristics of the output device such as dot shape and dot gain must be taken into consideration. The **-gcorr** option can be used to specify a different mapping of gray levels.

For very light or very dark images, the halftoning algorithms can be automatically recalibrated to preserve details that would be lost using the default calibration. See the **-alg** option for more information.

To maintain the image quality, scaling must be done prior to halftoning. The halftoning algorithm is very computation-intensive. Unless the images are small, **GIF to AFP** cannot process the color images fast enough to feed even a slow printer.

The size and position of the output image depend on several factors:

- The size specified to the transform
- The form map specified at print time
- The forms and options loaded in the printer

If the image is too large to fit on the page, it is trimmed to size by default. Use the **-fit scale** option to instruct the printer to scale the image to the paper size. If the paper size is not specified explicitly via the **-paper** option, the paper size defaults to US letter size (8.5 by 11 inches). If the image is larger than this, the paper dimensions are increased as necessary. If the paper size is specified explicitly, it is not increased if the image does not fit on paper. The options **-l** and **-w** have the same effect as **-paper**.

The size of the actual image (as opposed to the paper size) is controlled by the **-scale** option. You can either specify a value of **orig** for the **-scale** option or give an actual size. If you specify **orig**, the output image is the same size as the input image. If you specify **-scale** with an actual size, the output image is scaled to the desired size. You can also specify a percentage for enlargement or reduction.

Even if you specify **-scale orig**, the image might still have to be scaled if the input file specifies non-square pixels. By default, the transform leaves scaling to the printer. The exceptions are:

- Images that are being halftoned, which are always scaled in the transform
- Images that have different resolutions in X and Y directions (non-square pixels)

**Note:** Because GIF files do not specify resolutions, the image is assumed to have the resolution of the output device.

You can use the **-alg** option to instruct the transform to perform internal image scaling. Options **-alg**, **-clean**, and **-ink** choose and configure various scaling algorithms.



GIF images are compressed using the LZW algorithm. Because LZW compression is not part of any current IOCA function set, **GIF to AFP** always reads and decompresses the image.

## Limitations

- Timing data from GIF animation sequences is ignored.
- Animation sequences are processed as unrelated images.

## Acknowledgments

This software is partially based on the Independent JPEG Group's JPEG compression and decompression code.

## Options and values

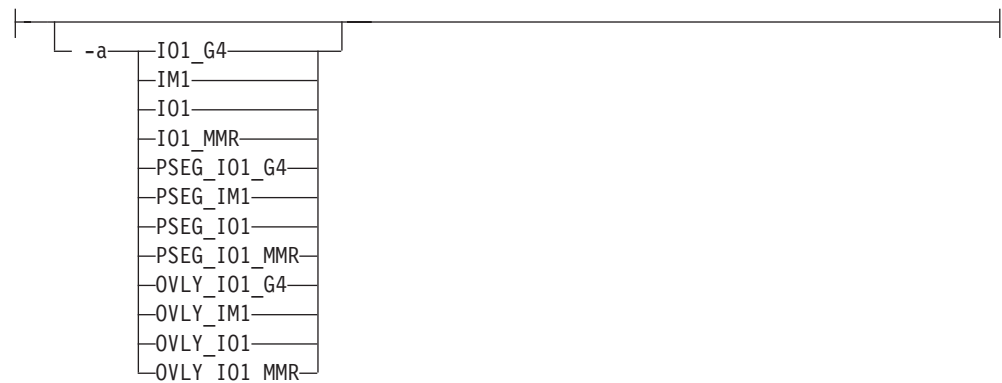

- Choice of the output image type. The first syntax chooses between the IOCA FS 10 (**ioca**, **ioca10**), IOCA FS11 (**ioca11**), and IM1 output. IOCA FS10 and IM1 yield bi-level images, while IOCA FS11 results in 4-bit or 8-bit gray or 24-bit color output (see option **-outbits**). Currently, the only product that supports IOCA FS11 is AFP Workbench. The output compression algorithm is set using the option **-cmp**. To set the page type (page, overlay, page segment or object), use the **-pagetype** option.
- The second syntax is to maintain compatibility with the **PostScript to AFP** transform, and sets the image type (**IO1** for IOCA FS10 or **IM1** for IM1 output), compression (**G4** for Group 4 or **MMR** for Group 3), and page type (**PSEG** for page segment or **OVLY** for overlay). If **PSEG** or **OVLY** is not specified, the output is a printable page. If no compression algorithm is specified, the output is not compressed. The second syntax cannot be used for IOCA FS11 output.
- Some older printers do not support IOCA images. In such cases, the IM1 output type should be chosen. IM1 images are uncompressed and thus use more space. The processing might also take longer since the IM1 image cannot be scaled by the printer and so internal scaling algorithms must be used. See option **-alg**.
- The default is **ioca** for IOCA FS10 output compressed using Group 4 algorithm.



- Choice of the scaling and halftoning algorithms. You can specify multiple choices, separated by commas, for one **-alg** option. The effect is the same as specifying multiple **-alg** options. For example, `-alg htfs,htcal` is equivalent to `-alg htfs -alg htcal`.

The scaling algorithms are:

- If **afp** is chosen, the scaling is done using the default algorithm in the printer. This makes the transform much faster. If the image must be reduced, however, this algorithm might drop some information from the image, such as thin lines.
- **alg1** activates the internal scaling algorithm to scale the image explicitly to the specified size. This algorithm does not discard any ink. “White space” in the image, however, might be lost (that is, features close to one another might merge). This algorithm makes the transform run longer, and might occasionally make for a “dirty” image, since the occasional “noise pixels” in the scanned images tend to be amplified.
- **alg2** activates the more flexible version of **alg1**. If this algorithm is selected, option **-clean** can be used to specify the amount of ink “cleanup” to be performed. Option **-clean 0.0** makes the algorithm **alg2** perform like **alg1** (although more slowly). Increasing the value specified in **-clean** discards more and more ink, until **-clean 1.0** results in a blank page.
- **alg3** activates a scaling algorithm that works by deleting or duplicating rows and columns in the image. This is a fast general-purpose algorithm.
- For bi-level images, the default is **afp** if the output image type is IOCA and **alg3** if the output image type is IM1. For color images with bi-level output, the scaling is always done prior to the halftoning algorithm. If a grayscale or color output is chosen (**-a ioca11**), this option is ignored and the algorithm is set to **afp**.

The halftoning algorithms are:

- **htod1** uses an ordered dither with a screen derived from the value of the **-thresh** option. The default is an 85 line per inch screen.
- **htfs** uses the Floyd-Steinberg algorithm.
- **htcal1** recalibrates the halftoning algorithm for each image. **htcal1** forces the transform to read the whole image into memory and requires an additional pass through the image. It should be used only for very light or very dark images.

- The default is **htod1**. Each halftoning algorithm uses a different internal default calibration curve. If the automatic calibration is turned on, a different set of calibration curves is used.
- See options **-clean**, **-gcorr**, **-ink**, **-paper**, **-scale**, **-thresh**, **-l**, **-w**, **-x**, and **-y**.



- The internal scaling algorithm **alg2** allows for variable thresholding. The scaled pixel is declared painted if the fraction of its area greater than the threshold is painted in the original image. The value `x.xxx` is a real number between zero and 1 inclusive and gives this threshold.
- If the option **-clean 0.0** is issued, **alg2** behaves like **alg1** and turns on a pixel as long as any part of the pixel has been painted in the original image. **-clean 1.0** results in a blank image because the output pixels are never painted.
- The setting **-clean 0.95** and **0.9999999** turns on the pixels that had essentially all the area painted in the original picture. Depending on the data, most of the image will probably be preserved. Increasing **-clean** by a small amount to **1.0** erases the image. If the scaling algorithm is not **alg2**, this option is ignored. The default is **-clean 0.5**.



- Choice of the output image compression algorithm:
  - none** Uncompressed output
  - mh** ITU-T T.4 G3 Modified Huffman
  - mmr** IBM Modified Modified Read
  - g3** ITU-T T.4 G3 Modified Read
  - g4** ITU-T T.6 G4
  - jpeg** JPEG non-differential Huffman coding with baseline DCT. The output image data should be compressed to reduce the file sizes and increase the printing speed.
- The default compression is ITU-T T.6 Group 4 for bi-level images and no compression for gray scale or color images. Some printers might not support Group 4 compression algorithm and require use of the **-cmp** option to choose a different one. The JPEG algorithm can compress only 8-bit gray scale and 24-bit color images. 4-bit gray scale images cannot be compressed.



- Image cropping. *t, b, l, r* specify how much should be cropped from the image top, bottom, left edge, and right edge. The numbers are floating point and can be either positive or negative. Negative numbers indicate that a blank space should be inserted. The units are inches, millimeters, points, and dots (pels). The default is dots. The cropping is specified in the context of the output page, so that “top” means the top of the output page and so on, regardless of the **-rot** option. To crop, the transform enlarges the image by the amount to be cropped, then crops the specified amount by manipulating the actual bitmap. The resulting image has the size as specified by the explicit (or implicit) **-scale** option. See also option **-j**.
- If **-fit trim** is specified, the right and the bottom edge of the image are not cropped. Instead, the image grows as necessary. Because **-fit trim** causes the output data stream to contain the “position and trim” specification, the printer discards any extra image.



Determines whether the printer behavior will be position-and-trim or scale-to-fit if the image is too large to fit on the paper. The default is **trim**.

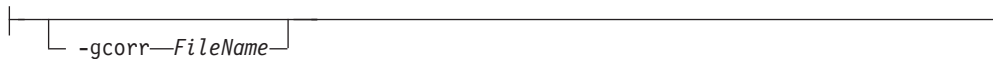

- Specifies a *FileName* with a gray scale mapping table for halftoning of the gray scale and color images to bi-level for output. The *FileName* you specify can be a fully qualified filename. If a path is not specified, Transform Manager looks in `/opt/IBM/itm/hn/resources/common/color` on the Linux workstation.
- The mapping table must be provided to compensate for the printing characteristics of the particular output device and paper type, such as dot gain. This file must contain either:
  - 256 real numbers, one for each level of gray in the 8-bit gray scale image
  - The PostScript **settransfer** operator
- The algorithm converts every image to 8-bit gray scale before applying the halftoning algorithm. The default might not produce the halftone image quality that your printer is capable of. Mapping tables for several different IBM engine types and line screens are supplied with Transform Manager and are installed in `/opt/IBM/itm/hn/resources/common/color` on the Linux workstation. To tune your image quality, select the file that matches your printer model. See also options **-alg** and **-thresh**. PostScript code submitted via the **-thresh** option can have the same effect as **-gcorr**.

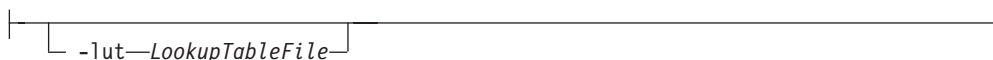

- Specifies the *FileName* for the color conversion lookup table file. The *FileName* you specify can be a fully qualified filename. If a path is not specified, Transform Manager looks in `/opt/IBM/itm/hn/resources/common/color` on the Linux workstation.
- Fast and accurate conversion between color spaces can be implemented as a multidimensional lookup with an interpolation algorithm for missing nodes. The file specified with the **-lut** option must contain a valid lookup table for the conversion between the input and output color spaces. The lookup tables currently come in either ASCII (.lut) or binary formats (.lutbin).

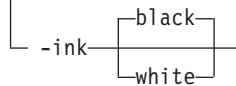

- This option is used only with scaling algorithm **alg1** or **alg2**. The GIF images can be either black on white or white on black. The internal scaling algorithm must know which, because “ink” is preserved at the expense of “non-ink”. The default value, “black”, indicates that the image is black on white.
- If the option **-inv** is used to print the reversed image, the inversion is done as the data is read by the transform, before any processing is done. The black or white must thus be specified in the terms of the printed image, not in the terms of the input GIF image.

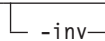

Reverses the image. Areas that are black in the original image become white and vice versa. The reversed image might be either black on white or white on black, depending on the original image.

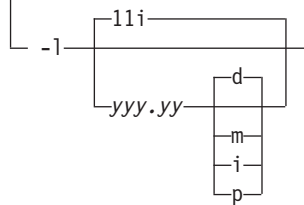

- Specifies the paper length. The optional units are **dots** (pels), **millimeters**, **inches**, or **points**.
- The default unit is dots. If the unit is dots, decimals (if any) are ignored. The default paper length is 11 inches.
- See options **-w** to set the paper width or **-paper** to set both dimensions at the same time.

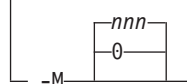

Limits the amount of memory available to **GIF to AFP**. *nnn* is the maximum amount of memory in kilobytes. A value of **0** means there is no memory limit. *nnn* can be set from **0** to the maximum value that the operating system allows. The default is **0**.

**-nosniff**

See **-sniff**.

**-nov** See **-v**.

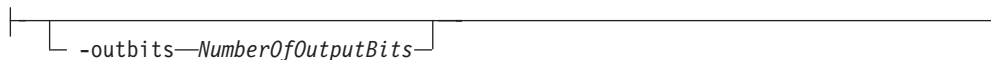

Sets the number of bits per pel in output. This value must be **1**, **4**, **8**, or **24**. If the output image type is IOCA FS10 or IM1, the number of output bits is set to **1** and this option is ignored. For IOCA FS11 output, the default is **24**. This number represents the maximum number of bits used per pel. Thus, even if the number of bits is set to **24**, a 4-bit grayscale image is still displayed in 4-bit format.



Sets the output color model to RGB, YCbCr, or YCrCb if the image type is IOCA FS11 and the number of output bits is 24. Otherwise, this option is ignored. The default is **ycbcr**.

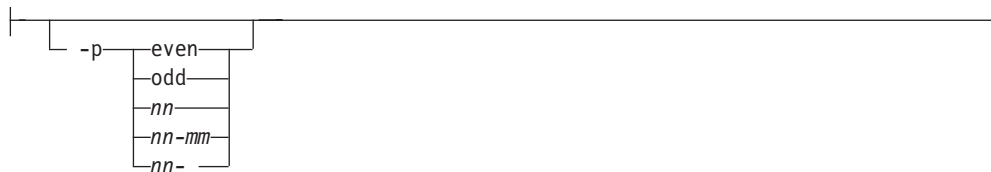

- Specifies that the output should only contain the specified pages. If no **-p** option is given, all the pages are output. Multiple **-p** options can be specified. Their effect is cumulative. Regardless of the order in which the pages are specified, they are always printed in ascending order. The recognized values are:
  - even** Print all even pages
  - odd** Print all odd pages
  - nn* Print page *nn*
  - nn-mm* Print pages *nn* to *mm*, inclusive
  - nn-* Print all pages starting with page *nn*
- Pages are numbered starting with 1.
- You can use **-p** when the **GIF to AFP** transform is processing one file at a time. This flag is ignored if you specify multiple files within the same job. transform is processing one file at a time.



- Sets the output page type to be page, overlay, page segment or object. The same page type is set for every page in the output. Thus, unless option `-p` is used to select a single page, multiple page segments or overlays are stored in the output file.
- The default is **page**.
- See option `-a`.

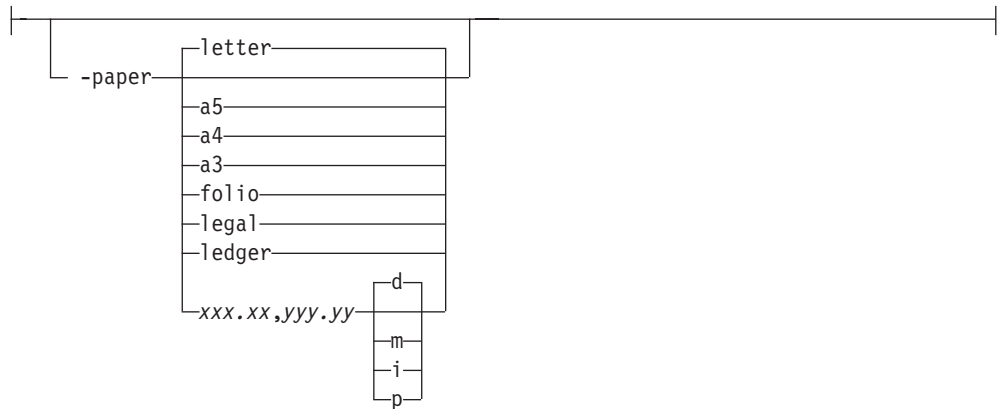

Specifies the output paper size. The supported values are:

- a3** A3 format (297 by 420 mm or 11.69 by 16.54 inches)
- a4** A4 format (210 by 297 mm or 8.27 by 11.69 inches)
- a5** A5 format (148 by 210 mm or 5.83 by 8.27 inches)
- letter** 8.5 by 11 inches (216 by 279 mm)
- folio** 8.5 by 13.0 inches (216 by 330 mm)
- legal** 8.5 by 14.0 inches (216 by 356 mm)
- ledger** 11.0 by 17.0 inches (279 by 432 mm)

`xxx.xx,yyy.yy`

Horizontal and vertical page dimensions. The optional units are: **dots** (pels), **millimeters**, **inches**, or **points**.

The default page size is **letter**. If `-paper` is not used, the paper size is increased, if necessary, to contain the output image.



The output device resolution, specified in dots per inch. The default is **300**.

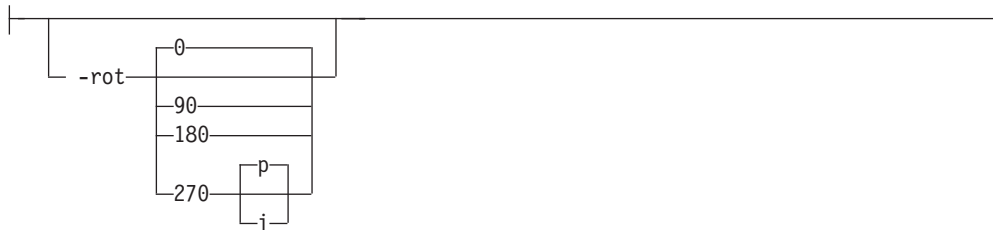

- The image is rotated in the clockwise direction by the amount specified. The default is zero, that is, no rotation.  
If **p** is specified, the transform sets the output datastream in such a way that the printer performs the actual image rotation. If **i** is specified, the transform rotates the output bitmap. When **i** is chosen, the transform takes much longer to run and uses much more memory. If no letter is specified, the default or any previous value remains in force.
- The default is **p**.

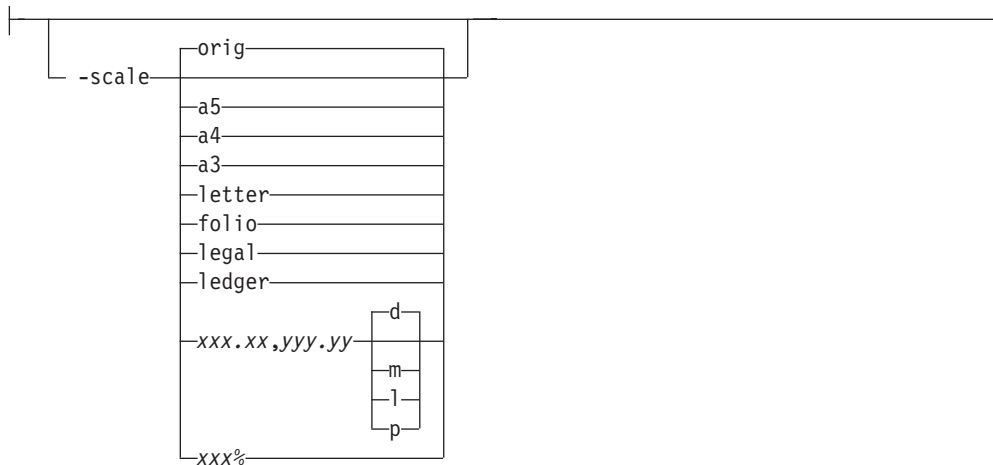

Specifies the output image size. The image is scaled to this size and centered in the area defined by the paper size and margin options. The supported values are:

**orig** Preserve the input image size, regardless of the printable paper area

**a3** A3 format (297 by 420 mm or 11.69 by 16.54 inches)

**a4** A4 format (210 by 297 mm or 8.27 by 11.69 inches)

**a5** A5 format (148 by 210 mm or 5.83 by 8.27 inches)

**letter** 8.5 by 11 inches (216 by 279 mm)

**folio** 8.5 by 13.0 inches (216 by 330 mm)

**ledger** 11.0 by 17.0 inches (279 by 432 mm)

`xxx.xx,yyy.yy`

Horizontal and vertical page dimensions. The optional units are: **dots** (pels), **millimeters**, **inches**, or **points**.

`xxx%` Magnification relative to the original image size. Numbers below 100% mean reduction, while numbers above 100% mean enlargement. For example, **-scale 200%** causes the output image to be twice as long and twice as wide as the input image.

The default image size is **orig**.



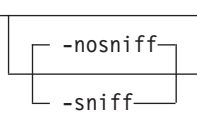

- Turns automatic conversion to black on white for bi-level images on (**-sniff**) or off (**-nosniff**). The automatic conversion algorithm counts the number of 0 and 1 bits in the image. If there are fewer zeros, it assumes the printed features are represented by zeros (white on black), and inverts the image to be black on white. The detection and conversion are done after the conversion specified by the Photometric Interpretation tag is applied (if any).
- This option is ignored if the image is not bi-level. The default is **-nosniff**.

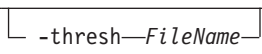

- Specifies a *FileName* that contains a PostScript Type 1 or Type 3 halftone dictionary. The *FileName* you specify can be a fully qualified filename. If a path is not specified, Transform Manager looks in **/opt/IBM/itm/hn/resources/common/color** on the Linux workstation.
- Halftone dictionaries for several different IBM engine types and line screens are supplied with Transform Manager and are installed in the **/opt/IBM/itm/hn/resources/common/color** on the Linux workstation. To tune your image quality, select the file that matches your printer model.
- Alternatively, the PostScript code can specify the **setscreen** operator instead of a Type 1 dictionary. The halftone cell in the dictionary is used to overwrite the default ordered dither clustered dot halftone cell. If the PostScript code contains a transfer function, either in the halftone dictionary or specified by the **settransfer** operator, the current grayscale correction curve is overwritten as if **-gcorr** were used.

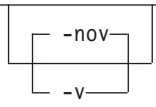

- Turns verbose mode on (**-v**) or off (**-nov**).
  - When verbose mode is on, the transform prints a message as it opens each resource file, then echoes the command line, then prints a message for each file name as it is processed.
  - When verbose mode is off, the transform prints only error messages.
- The default is **-nov**.

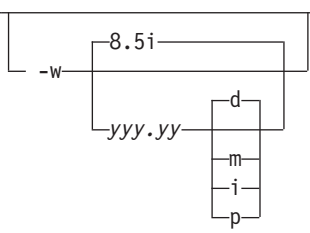

- Specifies the paper width. The optional units are **d**ots (pels), **m**illimeters, **i**nches, or **p**oints.

- The default unit is dots. The default page width is 8.5 inches.
- See options **-l** to set the paper length or **-paper** to set both dimensions at the same time.

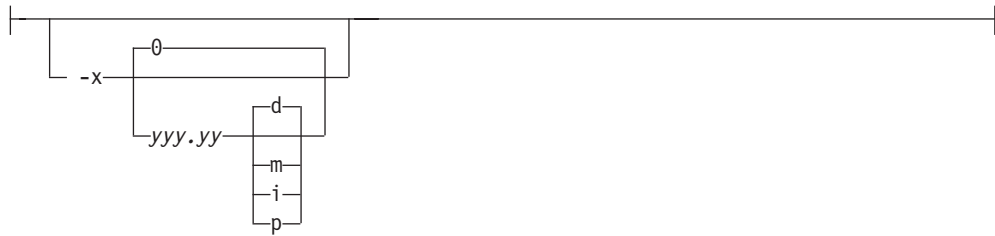

- Specifies the left margin. The optional units are **dots** (pels), **millimeters**, **inches**, or **points**.
- The default unit is dots. The default is zero (no margin).

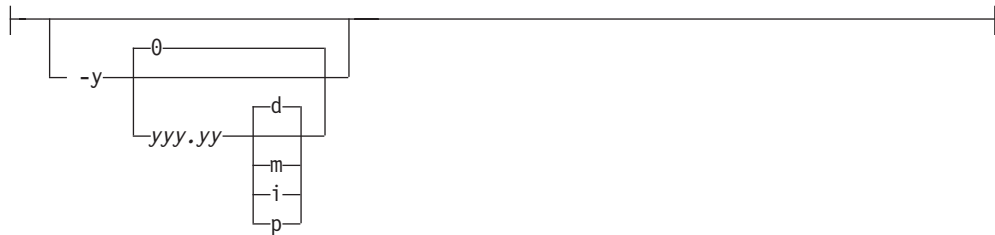

- Specifies the top margin. The optional units are **dots** (pels), **millimeters**, **inches**, or **points**.
- The default unit is dots. The default is zero (no margin).

## Transform JPEG data to AFP

This section describes the **JPEG to AFP** transform and includes its syntax and options and values.

### Syntax

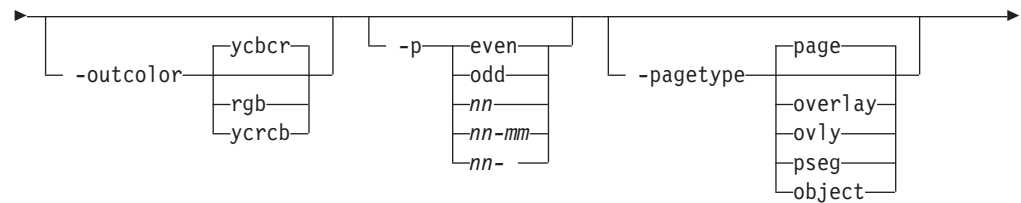
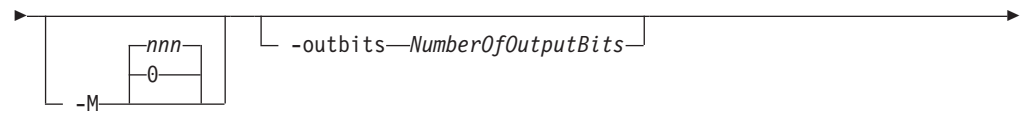
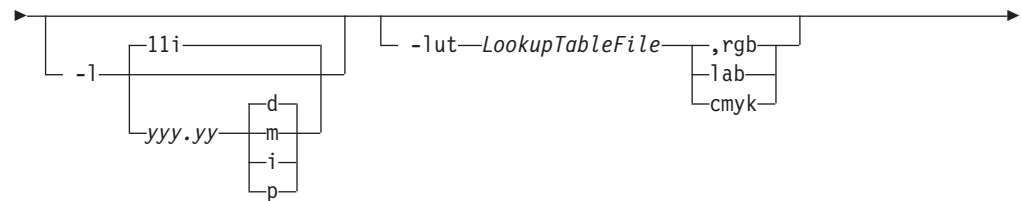
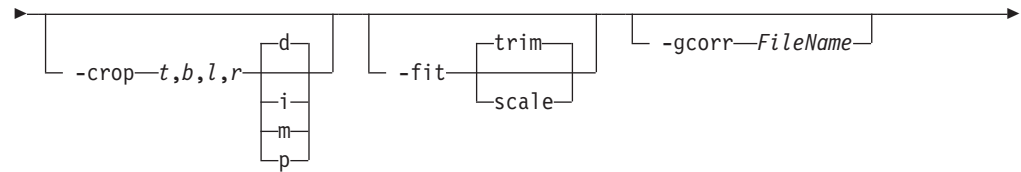
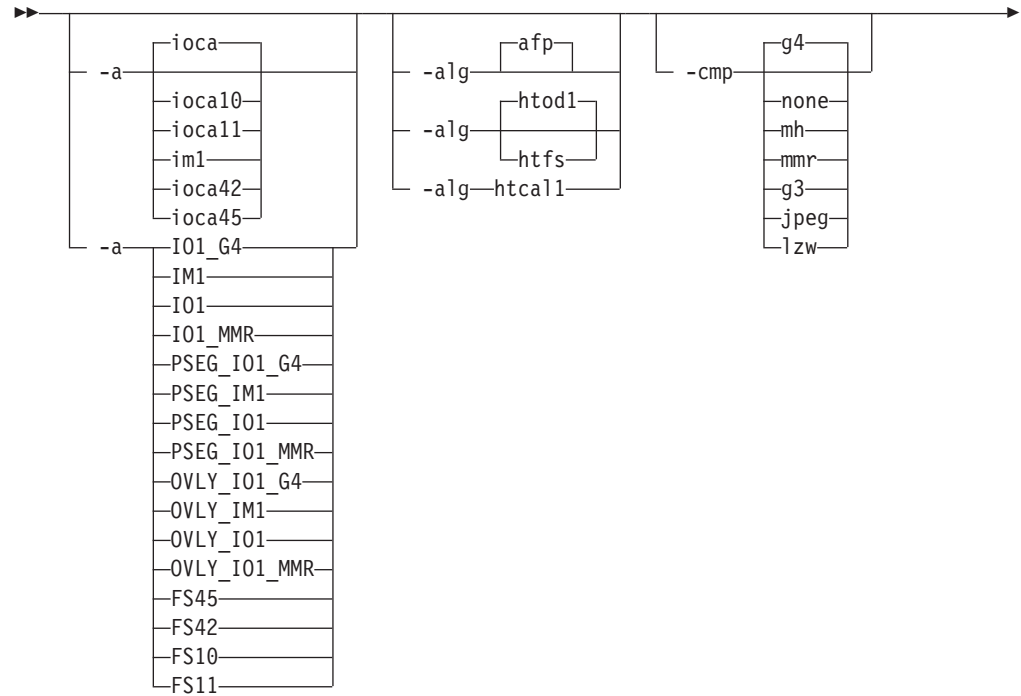

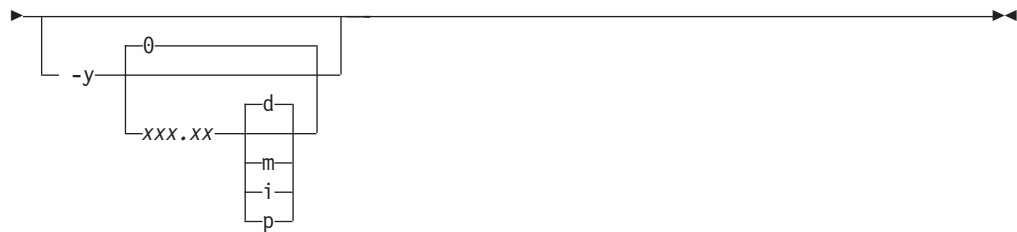
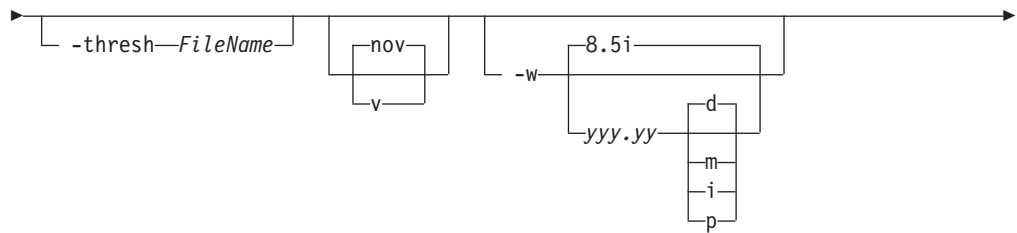
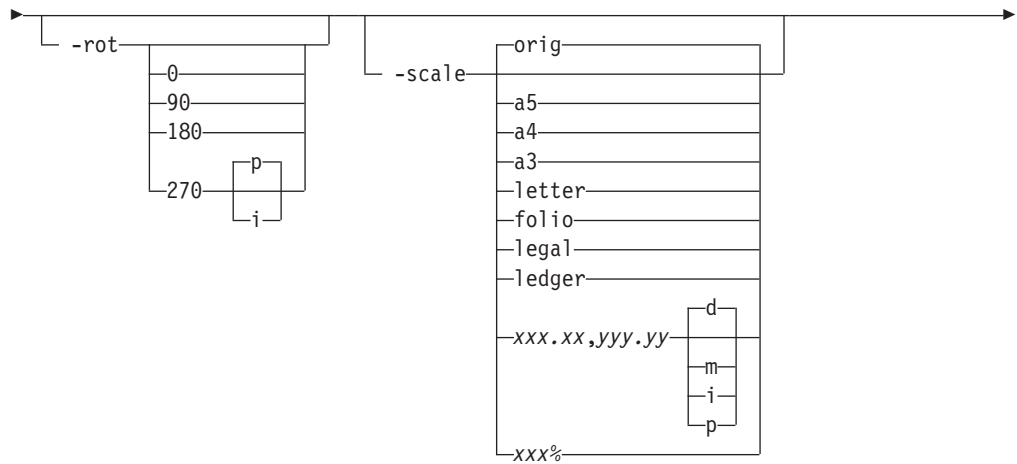
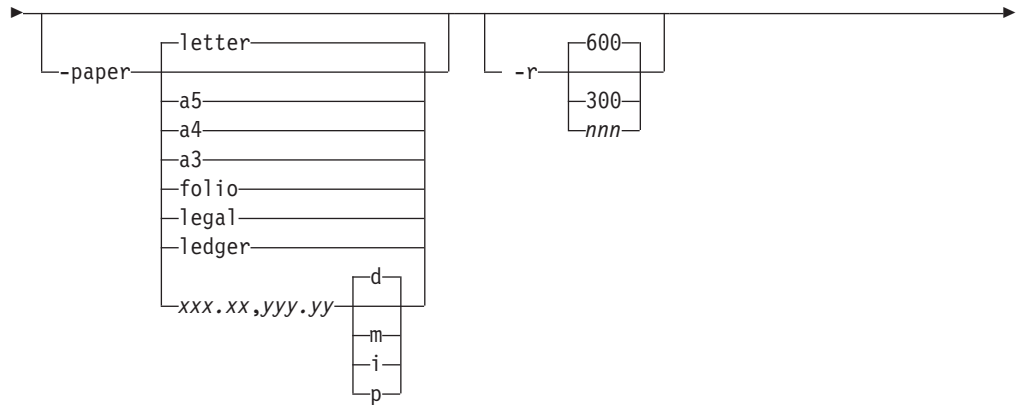

## Description

Use the **JPEG to AFP** transform to transform a JPEG (Joint Photographic Experts Group) data stream into an AFP (MO:DCA-P).

The transform can process images compressed using baseline lossy JPEG compression. Only 8 bits per channel and Huffman coding are supported. The output can be bi-level (IM1 or IOCA FS10), 4-bit or 8-bit gray scale, or 24-bit YCbCr color (IOCA FS11), bi-level or 4-bit banded CMYK image at 1-bit per band (IOCA

FS42), or a superset of FS42 that also contains 32-bit banded CMYK images, compressed with either JPEG or LZW algorithms (IOCA FS45). The transform automatically uses halftoning to convert the gray scale and color images to bi-level.

## Data transformations

If the input image is gray scale or color, and the output image type is bi-level (for example, IOCA FS10, or IM1), the transform internally scales the image to the desired size, then uses a halftoning algorithm (ordered dither, the default, or Floyd-Steinberg) to convert it to bi-level. In converting the image to bi-level, the characteristics of the output device, such as dot shape and dot gain, must be taken into consideration. The halftone screen and the calibration are extremely printer dependent. While the transform does contain an internal default (85 LPI screen at 45 degrees), an appropriate screen should be used and the halftone should be calibrated properly for best quality.

Some printers, such as the InfoPrint 4000, have two engines, one for each side of the sheet. Each engine commonly has a different calibration. Options **-thresh** and **-gcorr** provide the mechanism to specify halftone screen, gray scale correction curves, and rules for switching calibration based on the engine used to print a particular page. For very light or very dark images, the halftoning algorithms can be automatically recalibrated to preserve detail that would be lost using the default calibration. See option **-alg**.

To maintain the image quality, scaling must be done prior to halftoning. The halftoning algorithm is very compute-intensive. Unless the images are small, **JPEG to AFP** might not be able to process the color images fast enough to feed even a slow printer.

To achieve good image quality for the CMYK output, the input image colors must be converted to CMYK, bearing in mind the characteristics of the particular halftones used to generate the output image. The color conversion is done using a multidimensional lookup table, which is specified with the **-lut** option. If the transform can not determine the appropriate lookup table or the lookup table is missing, a simple conversion of RGB to CMY is performed using the 255- algorithm. This conversion does not use black and generally leads to poor color quality.

The size and the position of the output image on the page depends on several factors. In addition to the size specified to the transform, the result depends on the form map specified at print time and also on the form and options loaded in the printer. If the image is too large to fit on the page, it is trimmed to size by default. Use the **-fit** option to instruct the printer to scale the image to paper size. If the paper size has not been specified explicitly with the **-paper** option, the paper defaults to US letter (8.5 by 11 inches). If the image is larger than this, the paper dimensions are increased as necessary. If the paper size has been specified explicitly, it is not increased if the image will not fit on paper. Options **-l** and **-w** have the same effect as **-paper**.

The size of the actual image, as opposed to the paper size, is controlled by the **-scale** option. The **-scale** option can either specify "**orig**", or give an actual size. If **orig** has been specified, the output image has the same size as the input image. If **-scale** with an actual size has been specified, the output image is scaled to the desired size. A percentage enlargement/reduction can also be specified.

Even if **-scale orig** has been specified, the image may still need to be scaled if the input resolution is different from the output resolution. By default, the transform

leaves scaling to the printer. The exceptions are images that are being halftoned, which are always scaled in the transform, and images that have different resolutions on the X and Y directions. The **-alg** option can be used to instruct the transform to perform internal image scaling. Options **-alg** and **-ink** choose and configure various scaling algorithms used by the transform.

**Note:** Because JPEG files do not specify resolutions, the image is assumed to have the resolution of the output device.

If possible, **jpeg2afp** just wraps the JPEG raster data in MODCA-P headers. This does not change the compression algorithm used in the data, even though it might be different than the output compression algorithm specified on the command line. The data is wrapped only if no changes are to be made in the image and if the compression algorithm is supported by the IOCA standard. Besides the uncompressed data, the bi-level compression algorithms supported both by JPEG and IOCA are ITU-TSS T.4 Group 3 and T.6 Group 4 algorithms.

For 8-bit grayscale and 24-bit color images, both TIFF and IOCA FS11 support JPEG compression algorithms. However, TIFF and JPEG standards have different subsampling defaults than IOCA FS11. Thus, most 24-bit color images are not suitable for wrapping, even if they use a JPEG compression algorithm and a color model supported by IOCA FS11. Also, JPEG is a lossy compression algorithm. Decompressing a JPEG image and then recompressing it again for output might result in reduced image quality. For that reason, the default is to use no compression for the gray or color output.

Be aware that not all the printers support all the recognized IOCA compression standards. To make sure that the transform decompresses the data and recompresses it using the specified algorithm, use the **-force** option. If the output image is IM1, the image is always decompressed and scaled in the transform.

The JPEG images are often divided into many segments for efficient memory handling. Some printers will terminate the printing in error if the page is too complex. For that reason, **jpeg2afp** decompresses, repartitions, and compresses the data if it determines there are too many segments in the picture.

### **Limitations**

- Only Huffman coding with baseline DCT JPEG algorithm is supported.
- At most 8-bit grayscale and 24-bit color are supported.

### **Acknowledgments**

This software is based in part on the work of the Independent JPEG Group.

### **Options and values**

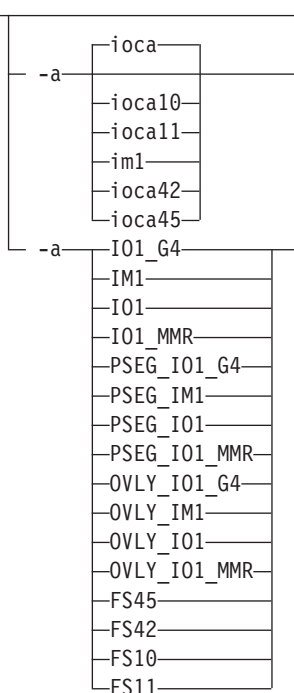

- Choice of the output image type. The first syntax chooses between the IOCA FS 10 (**ioca**, **ioca10**), IOCA FS11 (**ioca11**), IM1, IOCA FS42 (**ioca42**), and IOCA FS45 (**ioca45**) output. IOCA FS10 and IM1 yield bi-level images, while IOCA FS11 results in 4-bit or 8-bit gray or 24-bit color output (see option **-outbits**). Currently, the only product that supports IOCA FS11 is AFP Workbench. IOCA FS42 can contain either bi-level or 4-bit banded CMYK image at 1-bit per band. IOCA FS45 is a superset of FS42 that also contains 32-bit banded CMYK images, compressed with either JPEG or LZW algorithms. The output compression algorithm is set with the **-cmp** option. To set the page type (page, overlay, page segment, or object), use the **-pagetype** option. FS45 produces IOCA FS45 output.
- The second syntax is to maintain compatibility with the **PostScript to AFP** transform, and sets the image type (**IO1** for IOCA FS10 or **IM1** for IM1 output), compression (**G4** for Group 4 or **MMR** for Group 3), and page type (**PSEG** for page segment or **OVLY** for overlay). If **PSEG** or **OVLY** is not specified, the output is a printable page. If no compression algorithm is specified, the output is not compressed. The second syntax cannot be used for IOCA FS11 output.
- Some older printers do not support IOCA images. In such cases, the IM1 output type should be chosen. IM1 images are uncompressed, and thus, use more space. The processing might also take longer since the IM1 image cannot be scaled by the printer, so internal scaling algorithms must be used. See option **-alg**.
- The default is **ioca** for IOCA FS10 output compressed using the Group 4 algorithm.

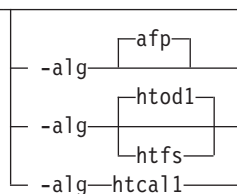

- Choice of the scaling and halftoning algorithms. You can specify multiple choices, separated by commas, for one **-alg** option. The effect is the same as specifying multiple **-alg** options. For example, `-alg htfs,htcal` is equivalent to `-alg htfs -alg htcal`.

The scaling algorithms are:

- If **afp** is chosen, the scaling is done using the default algorithm in the printer. This makes the transform much faster. If the image must be reduced, however, this algorithm might drop some information from the image, such as thin lines.
- For color images with bi-level output, the scaling is always done prior to the halftoning algorithm. If a grayscale or color output is chosen (**-a ioca11**), this option is ignored and the algorithm is set to **afp**.
- The halftoning algorithms are:
  - htod1** uses an ordered dither with a screen derived from the value of the **-thresh** option. The default is an 85 line per inch screen.
  - htfs** uses the Floyd-Steinberg algorithm.
  - htcal1** recalibrates the halftoning algorithm for each image. **htcal1** forces the transform to read the whole image into memory and requires an additional pass through the image. It should be used only for very light or very dark images.
- The default is **htod1**. Each halftoning algorithm uses a different internal default calibration curve. If the automatic calibration is turned on, a different set of calibration curves is used.
- See options **-gcorr**, **-paper**, **-scale**, **-thresh**, **-l**, **-w**, **-x**, and **-y**.

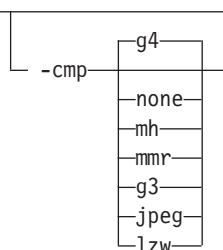

- Choice of the output image compression algorithm:
  - none** Uncompressed output
  - mh** ITU-T T.4 G3 Modified Huffman
  - mmr** IBM Modified Modified Read
  - g3** ITU-T T.4 G3 Modified Read
  - g4** ITU-T T.6 G4



**jpeg** JPEG non-differential Huffman coding with baseline DCT. The output image data should be compressed to reduce the file sizes and increase the printing speed.

**lzw** If **lzw** is specified, linework of 600 dpi is produced; otherwise, lossy JPEG at 300 dpi is produced. **lzw** only applies to FS45.

- The default compression is ITU-T T.6 Group 4 for bi-level images and no compression for gray scale or color images. Some printers might not support Group 4 compression algorithm and require using the **-cmp** option to choose a different one. The JPEG algorithm can compress only 8-bit gray scale and 24-bit color images. 4-bit gray scale images cannot be compressed.



- Image cropping. *t,b,l,r* specify how much should be cropped from the image top, bottom, left edge, and right edge. The numbers are floating point and can be either positive or negative. Negative numbers indicate that a blank space should be inserted. The units are inches, millimeters, points, and dots (pels). The default is dots. The cropping is specified in the context of the output page, so that “top” means the top of the output page and so on, regardless of the **-rot** option. To crop, the transform enlarges the image by the amount to be cropped, then crops the specified amount by manipulating the actual bitmap. The resulting image has the size as specified by the explicit (or implicit) **-scale** option. See also option **-j**.
- If **-fit trim** is specified, the right and the bottom edge of the image are not cropped. Instead, the image grows as necessary. Because **-fit trim** causes the output data stream to contain the “position and trim” specification, the printer discards any extra image.



Determines whether the printer behavior will be position-and-trim or scale-to-fit if the image is too large to fit on the paper. The default is **trim**.

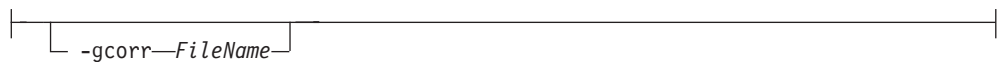

- Specifies a *FileName* with a gray scale mapping table for halftoning of the gray scale and color images to bi-level for output. The *FileName* you specify can be a fully qualified filename. If a path is not specified, Transform Manager looks in `/opt/IBM/itm/hn/resources/common/color` on the Linux workstation.
- The mapping table must be provided to compensate for the printing characteristics of the particular output device and paper type, such as dot gain. This file must contain either:
  - 256 real numbers, one for each level of gray in the 8-bit gray scale image
  - The PostScript **settransfer** operator
- The algorithm converts every image to 8-bit gray scale before applying the halftoning algorithm. The default might not produce the halftone image quality

that your printer is capable of. Mapping tables for several different engine types and line screens are supplied with Transform Manager and are installed in `/opt/IBM/itm/hn/resources/common/color` on the Linux workstation. To tune your image quality, select the file that matches your printer model. See also options `-alg` and `-thresh`. PostScript code submitted with the `-thresh` option can have the same effect as `-gcorr`.



- Specifies the paper length. The optional units are **dots** (pels), **millimeters**, **inches**, or **points**.
- The default unit is dots. If the unit is dots, decimals (if any) are ignored. The default paper length is 11 inches.
- See options `-w` to set the paper width or `-paper` to set both dimensions at the same time.

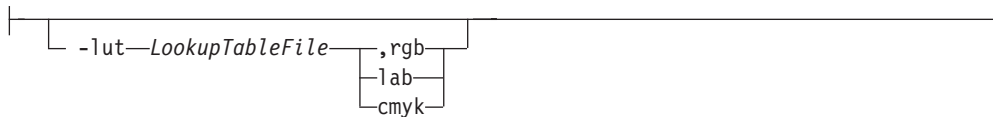

- Specifies the *FileName* for the color conversion lookup table file. The *FileName* you specify can be a fully qualified filename. If a path is not specified, Transform Manager looks in `/opt/IBM/itm/hn/resources/common/color` on the Linux workstation.
- Fast and accurate conversion between color spaces can be implemented as a multidimensional lookup with an interpolation algorithm for missing nodes. The file specified with the `-lut` option must contain a valid lookup table for the conversion between the input and output color spaces. The lookup tables currently come in either ASCII (.lut) or binary formats (.lutbin).
- If the optional colorspace tag is not provided, the table is assumed to match the input image. If there is a serious mismatch between the table and the image (for example, the table is RGB to CMYK and the input image is CMYK), the `-lut` is ignored for the image. Otherwise, it is used to convert the colors and any mismatch (for example, using a **lab** table for **rgb** data) results in corrupted output.
- If the colorspace tag is provided, then the transform uses the lookup table only for the relevant colorspace image. Multiple **lut** tables can be specified if the user is unsure of the input colorspace. If the **lut** files are binary, parsing extra files does not impose much of a performance penalty.

**Example:**

```
-lut 3170-005.rgb.cmyk.perceptual.lutbin,rgb
```

Where 3170-005 is the model-type; rgb.cmyk is for RGB images; and perceptual is the **color-rendering-intent** value.

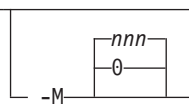

Limits the amount of memory available to **JPEG to AFP**. *nnn* is the maximum amount of memory in kilobytes. A value of **0** means there is no memory limit. *nnn* can be set from **0** to the maximum value that the operating system allows. The default is **0**.

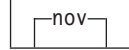

See **v** or **nov**.

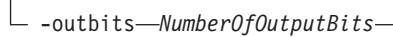

Sets the number of bits per pel in output. This value must be **1**, **4**, **8**, or **24**. If the output image type is IOCA FS10 or IM1, the number of output bits is set to **1** and this option is ignored. For IOCA FS11 output, the default is **24**. This number represents the maximum number of bits used per pel. Thus, even if the number of bits is set to **24**, a 4-bit grayscale image is still displayed in 4-bit format.

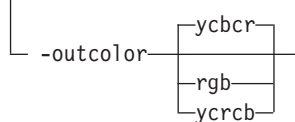

Sets the output color model to RGB, YCbCr, or YCrCb if the image type is IOCA FS11 and the number of output bits is 24. Otherwise, this option is ignored. The default is **ycbcr**.

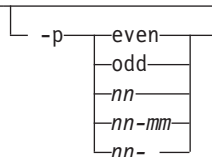

- Specifies that the output should only contain the specified pages. If no **-p** option is given, all the pages are output. Multiple **-p** options can be specified. Their effect is cumulative. Regardless of the order in which the pages are specified, they are always printed in ascending order.
- The supported values are:
  - even** Print all even pages
  - odd** Print all odd pages
  - nn* Print page *nn*
  - nn-mm* Print pages *nn* to *mm*, inclusive
  - nn-* Print all pages starting with page *nn*

- Pages are numbered starting with 1.
- You can use **-p** when the **JPEG to AFP** transform is processing one file at a time. This flag is ignored if you specify multiple files within the same job.

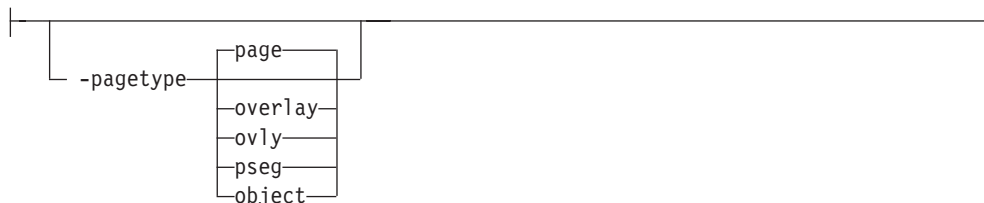

- Sets the output page type to be page, overlay, page segment or object. The same page type is set for every page in the output. Thus, unless option **-p** is used to select a single page, multiple page segments or overlays are stored in the output file.
- The default is **page**.
- See option **-a**.

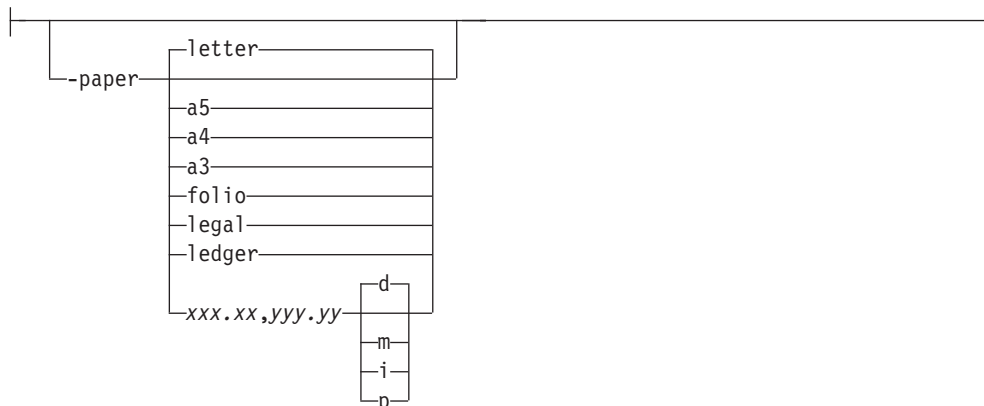

- Specifies the output paper size. The supported values are:
  - a3** A3 format (297 by 420 mm or 11.69 by 16.54 inches)
  - a4** A4 format (210 by 297 mm or 8.27 by 11.69 inches)
  - a5** A5 format (148 by 210 mm or 5.83 by 8.27 inches)
  - letter** 8.5 by 11 inches (216 by 279 mm)
  - folio** 8.5 by 13.0 inches (216 by 330 mm)
  - legal** 8.5 by 14.0 inches (216 by 356 mm)
  - ledger** 11.0 by 17.0 inches (279 by 432 mm)
- `xxx.xx,yyy.yy`  
Horizontal and vertical page dimensions. The optional units are **dots** (pels), **millimeters**, **inches**, or **points**.
- The default paper size is letter. If **-paper** is not used, the paper size is increased, if necessary, to contain the output image.
- See options **-l**, **-w**, and **-scale**.

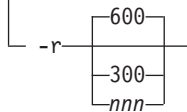

- The output device resolution, specified in dots per inch
- The default is **600**.

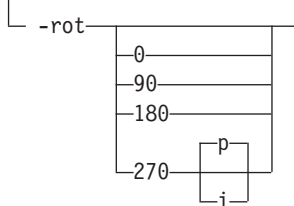

- The image is rotated in the clockwise direction by the amount specified. The default is zero, that is, no rotation.
- If **p** is specified, the transform sets the output datastream in such a way that the printer performs the actual image rotation. If **i** is specified, the transform rotates the output bitmap. When **i** is chosen, the transform takes much longer to run and uses much more memory. If no letter is specified, the default or any previous value remains in force.
- The default is **p**.

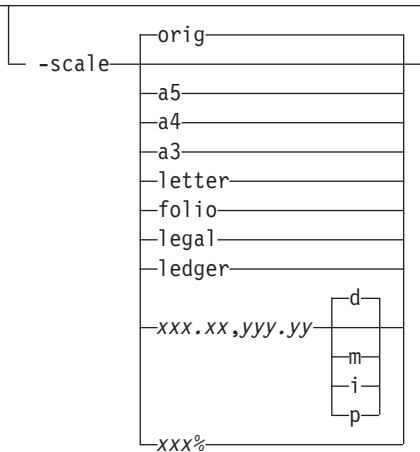

- Specifies the output image size. The image is scaled to this size and centered in the area defined by the paper size and margin options. The supported values are:
  - orig** Preserve the input image size, regardless of the printable paper area.
  - a3** A3 format (297 by 420 mm or 11.69 by 16.54 inches)
  - a4** A4 format (210 by 297 mm or 8.27 by 11.69 inches)
  - a5** A5 format (148 by 210 mm or 5.83 by 8.27 inches)
  - letter** 8.5 by 11 inches (216 by 279 mm)
  - folio** 8.5 by 13.0 inches (216 by 330 mm)

**legal** 8.5 by 14.0 inches (216 by 356 mm)

**ledger** 11.0 by 17.0 inches (279 by 432 mm)

*xxx.xx,yyy.yy*

Horizontal and vertical page dimensions. The optional units are: **dots** (pels), **millimeters**, **inches**, or **points**.

*xxx%* Magnification relative to the original image size. Numbers below 100% mean reduction, while numbers above 100% mean enlargement. For example, **-scale 200%** causes the output image to be twice as long and twice as wide as the input image.

- The default image size is **orig**.

`-thresh—FileName`

- Specifies a *FileName* that contains a PostScript Type 1 or Type 3 halftone dictionary. The *FileName* you specify can be a fully qualified filename. If a path is not specified, Transform Manager looks in **/opt/IBM/itm/hn/resources/common/color** on the Linux workstation.
- Halftone dictionaries for several different engine types and line screens are supplied with Transform Manager and are installed in the **/opt/IBM/itm/hn/resources/common/color** on the Linux workstation. To tune your image quality, select the file that matches your printer model.
- Alternatively, the PostScript code can specify the **setscreen** operator instead of a Type 1 dictionary. The halftone cell in the dictionary is used to overwrite the default ordered dither clustered dot halftone cell. If the PostScript code contains a transfer function, either in the halftone dictionary or specified by the **settransfer** operator, the current grayscale correction curve is overwritten as if **-gcorr** were used.

`-nov`  
`-v`

- Turns verbose mode on (**-v**) or off (**-nov**).
  - When verbose mode is on, the transform prints a message as it opens each resource file, then echoes the command line, then prints a message for each file name as it is processed.
  - When verbose mode is off, the transform prints only error messages.
- The default is **-nov**.

`-w`  
`8.5 i`  
`yyy.yy`  
`d`  
`m`  
`i`  
`p`

- Specifies the paper width. The optional units are **dots** (pels), **millimeters**, **inches**, or **points**.
- The default unit is dots. The default page width is 8.5 inches.

- See options **-l** to set the paper length or **-paper** to set both dimensions at the same time.



- Specifies the left margin. The optional units are **dots** (pels), **millimeters**, **inches**, or **points**.
- The default unit is dots. The default is zero (no margin).

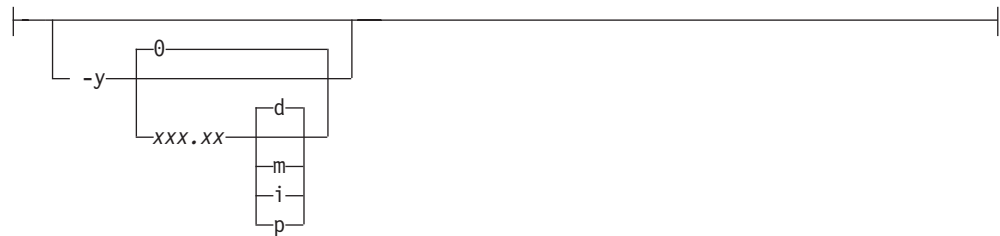

- Specifies the top margin. The optional units are **dots** (pels), **millimeters**, **inches**, or **points**.
- The default unit is dots. The default is zero (no margin).

## Transform PCL data to AFP

This section describes the **PCL to AFP** transform and includes its syntax and options and values.

### Syntax

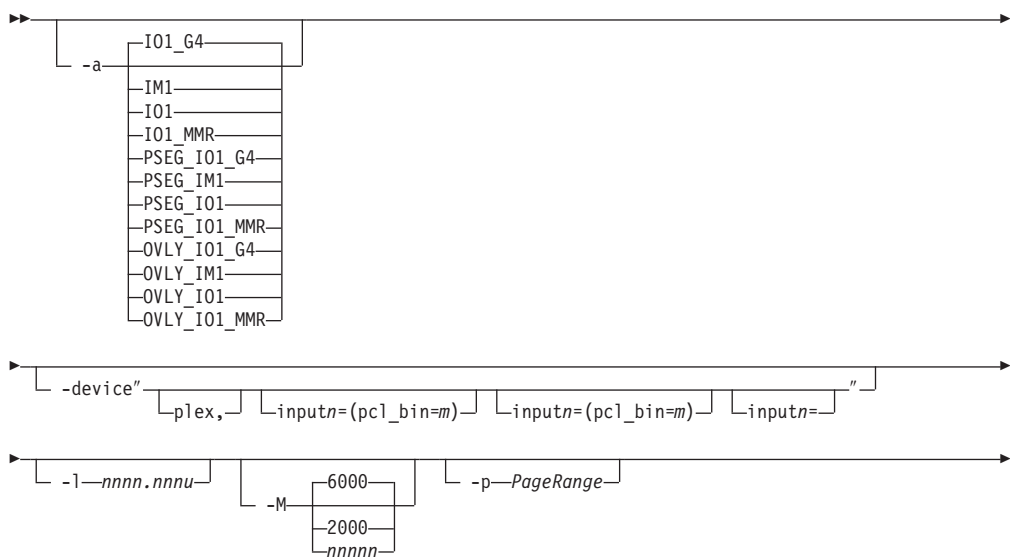

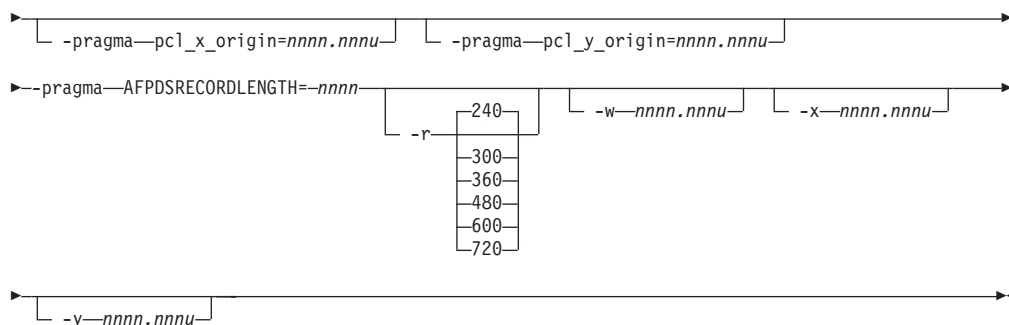

## Description

Use the **PCL to AFP** transform to transform a PCL data stream file into an AFP data stream file.

If you specify multiple values of the same flag, **PCL to AFP** uses the last value specified, with the exception of the **-p** flag. Multiple values of the **-p** flag are accumulated and the pages identified for printing are printed in normal numerical sequence, regardless of the order you specify.

The **PCL to AFP** transform uses these Embedded Microtype Fonts:

- Albertus Medium
- Albertus Extra Bold
- Antique Olive
- Antique Olive Italic
- Antique Olive Bold
- Arial
- Arial Italic
- Arial Bold
- Arial Bold Italic
- Clarendon Condensed Bold
- Coronet
- Courier Italic
- Courier Bold
- Courier Bold Italic
- Garamond Antiqua
- Garamond Kursiv
- Garamond Halbfett
- Garamond Kursiv Halbfett
- Letter Gothic
- Letter Gothic Italic
- Letter Gothic Bold
- Marigold
- CG Omega
- CG Omega Italic
- CG Omega Bold
- CG Omega Bold Italic
- Symbol
- CG Times
- CG Times Italic
- CG Times Bold
- CG Times Bold Italic
- Times New Roman
- Times New Roman Italic



- Times New Roman Bold
- Times New Roman Bold Italic
- Univers Medium
- Univers Medium Italic
- Univers Bold
- Univers Bold Italic
- Univers Condensed Medium
- Univers Condensed Medium Italic
- Univers Condensed Bold
- Univers Condense Bold Italic
- WingDings

The **PCL to AFP** transform also uses the Line Printer embedded bitmap font.

Font substitution occurs when a set of capabilities, such as Symbol Set, Spacing, Pitch, and Typeface, are compared to the fonts available to the rip, and the closest match wins. You cannot disable font substitution. If an error occurs during font substitution, the error is not logged. When a custom font is included in the data stream, and the PCL job refers to it, the custom font is used.

### Limitations

- PCL data can contain device commands (for example, to begin or end duplexing or to change the input bin). The AFP architecture defines those device functions in a form definition resource instead of the print data. To access those device functions (such as duplexing, and bin selection), you must specify them in the form definition or attributes file, or on a print command, when you print the job.

**Note:** Duplexing is the default.

- Resolution conversion algorithms might yield degraded appearance when used to reduce the resolution of a data stream. For this reason, **PCL to AFP** might degrade the appearance of higher-resolution data streams when used with 240-pel printers. You should verify that print fidelity is satisfactory.
- There are subtle differences between PCL4 and PCL5e when it comes to handling fonts. While many PCL4 files will work with **PCL to AFP**, some might not produce the expected output.

### Flags and values

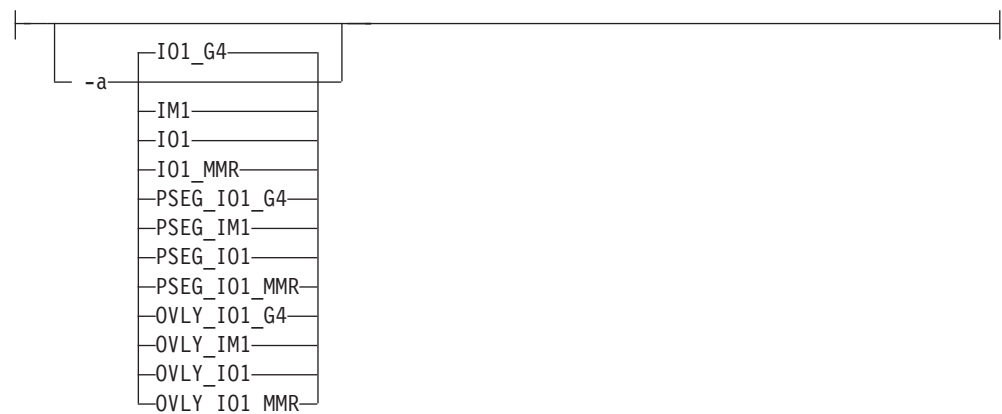

- The **-a** flag determines the type of AFP data stream image to generate for each page in the PCL file.

Values are:

| **IO1\_G4**

| Compressed Image Object Content Architecture (IOCA) image in  
| Modified TSS (formerly CCITT) T.6 G4 Facsimile Coding Scheme (G4  
| MMR) format. This is the recommended output type because it takes up  
| less space on the fixed disk, and it prints faster.

| **Note:** The IBM 3812 and 3816 printers do not support printing with an  
| image type of **IO1\_G4**. For these printers, specify an image type  
| of **IO1\_MMR** because it is the compressed image type supported  
| by these printers, and it will result in faster printing than  
| uncompressed image types.

| PPDS, PCL, and TCP/IP-attached IPDS™ printers can print IOCA images;  
| however, only channel-attached printers that have the Advanced Function  
| Image and Graphics (AFIG) feature installed can print IOCA images.  
| Therefore, if you are printing images on channel-attached printers without  
| the AFIG feature, select the **IM1** value.

| **IM1** IM1 image. This type of image is not compressed.

| **IO1** IOCA image. This type of image is not compressed.

| **IO1\_MMR**

| Compressed IOCA image in Modified Modified Read (MMR) format.

| **PSEG\_IO1\_G4**

| Page segment of the specified image type.

| **PSEG\_IM1**

| Page segment of the specified image type.

| **PSEG\_IO1**

| Page segment of the specified image type.

| **PSEG\_IO1\_MMR**

| Page segment of the specified image type.

| **OVLY\_IO1\_G4**

| Overlay of the specified image type.

| **OVLY\_IM1**

| Overlay of the specified image type.

| **OVLY\_IO1**

| Overlay of the specified image type.

| **OVLY\_IO1\_MMR**

| Overlay of the specified image type.

| **Note:** When generating page segments from multiple-page documents, you might  
| want to use the **-p** flag to select which page is to be made into a page  
| segment; otherwise, multiple page segments will be created, one for each  
| page of PCL.

| When generating overlays from multiple-page documents, you might want to  
| use the **-p** flag to select which page is to be made into an overlay;  
| otherwise, multiple overlays will be created, one for each page of PCL.

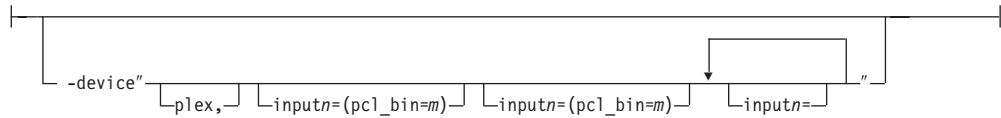

- The **plex** value specifies whether the transform recognizes or honors the plex commands in the data stream, and optionally, specifies how to associate the AFP input tray (**inputn**, where *n* is a value between 1 to 255) with the pcl bin (**pcl\_bin=m**, where *m* is a value between 0 to 59). When you do not specify **inputn=(pcl\_bin=n)** with **plex**, the plex command is used with no tray mappings.
- You can specify **inputn=(pcl\_bin=m)** up to twenty times.
- The number (*n*) you specify with **input** is the AFP input bin to be selected when the print description language tray selection characteristics are met.
- If you don't specify **plex**, the plex commands in the data stream are ignored.



- Specifies the maximum amount of time, in minutes, to spend processing the job.
- Values are:
  - 20** 20 minutes, the default
  - 1 to 9998**  
The timer ranges from 1 to 9998 minutes, in one-minute increments
  - 9999** No time limit

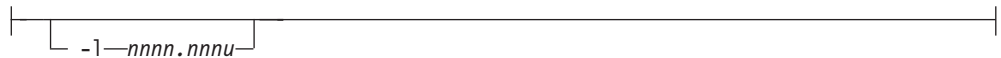

- Specifies the length of the generated image; *nnnn.nnn* is a number that can optionally contain a decimal point, and *u* is the units in inches (**i**) or millimeters (**m**). If you do not specify a unit (**i** or **m**), then **PCL to AFP** uses pels as the unit type. You cannot specify fractional values (that is, you cannot use a decimal point) for pels.

**Note:** If a text margin is already built into the file, try **-l11i** to set the length to 11 inches.

- For 240-pel resolution printers, values are:

**11i** 11 inches, the default

**16 to 5280**

The length can be from 16 pels to 5280 pels, 0.067i to 22.002i, or 1.701m to 558.852m. For example, the following are all valid:

```
-l 40m
-l 200.5m
-l 13i
-l 4000
```

- For 300-pel resolution printers, values are:

**11i** 11 inches, the default

**16 to 6600**

The length can be from 16 pels to 6600 pels, 0.053i to 22.001i, or 1.346m to 558.842m. For example, the following are all valid:

- l 40m
- l 200.5m
- l 13i
- l 5000

- For 480-pel resolution printers, values are:

**11i** 11 inches, the default

**16 to 10560**

The length can be from 16 pels to 10560 pels, 0.033i to 22.002i, or 0.838m to 558.852m. For example, the following are all valid:

- l 40m
- l 200.5m
- l 13i
- l 8000

- For 600-pel resolution printers, values are:

**11i** 11 inches, the default

**16 to 20400**

The length can be from 16 pels to 20400 pels, 0.0267i to 34.001i, or 0.678m to 863m. For example, the following are all valid:

- l 40m
- l 200.5m
- l 13i
- l 10000

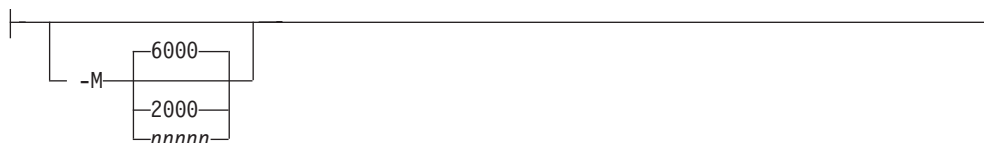

- Determines the maximum amount of memory, in KB, that the transform can use. This flag might be useful if you are processing large PCL jobs that require a lot of memory.
- Values are:

**6000** 6000KB (6MB), the default

**2000 to nnnnn**

The maximum memory ranges from 2000 to *nnnnn* (where *nnnnn* is the maximum upper limit the operating system allows) up to 64MB.

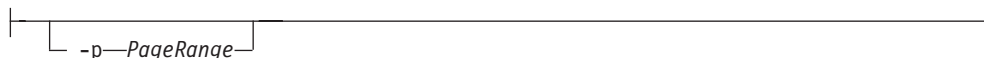

- Specifies that the output should only contain selected pages. When you specify multiple **-p** flags, the **PCL to AFP** transform accumulates them and prints the identified pages in normal numerical order, regardless of the order you specify. Examples of values include:
- Examples of values include:

**-p 1-10**

Output pages 1 through 10.

**-p 10-** Output pages from page 10 until the end of the job.

- You can use **-p** when the **PCL to AFP** transform is processing one file at a time. This flag is ignored if you specify multiple files within the same job.

```
-pragma-pcl_x_origin=nnnn.nnnu
```

Specifies an X presentation page origin of the generated image; *nnnn.nnnu* is a number that can optionally contain a decimal point, and *u* is the units in inches (i) or millimeters (m). If you do not specify a unit (i or m), then **PCL to AFP** uses pels as the unit type. You cannot specify fractional values, that is, you cannot use a decimal point, for pels. If this value is unspecified, zero is presumed.

```
-pragma-pcl_y_origin=nnnn.nnnu
```

Specifies an Y presentation page origin of the generated image; *nnnn.nnnu* is a number that can optionally contain a decimal point, and *u* is the units in inches (i) or millimeters (m). If you do not specify a unit (i or m), then **PCL to AFP** uses pels as the unit type. You cannot specify fractional values, that is, you cannot use a decimal point, for pels. If this value is unspecified, zero is presumed.

```
-pragma-AFPDSRECORDLENGTH=-nnnn
```

Use *nnnn* to specify the maximum number of bytes in a record. For example, `-pragma AFPDSRECORDLENGTH=8000` limits the record length to 8K. The default is 32000, and the value range is 8000 to 32000.

```
-r
  240
  300
  480
  600
```

- Specifies the resolution of the output image. Select the resolution based on the printer on which you will be printing the image.
- Values are:

<b>240</b>	240 pels-per-inch (for example, InfoPrint 3812, 3825, 3827, 3835, and 3900 printers), the default
<b>300</b>	300 pels-per-inch (for example, InfoPrint 3112, 3116, 4019, 4028, 4029, and 4039 printers and Hewlett-Packard printers)
<b>360</b>	360 pels-per-inch (for example, InfoPrint 5000 printers)
<b>480</b>	480 pels-per-inch
<b>600</b>	600 pels-per-inch (for example, InfoPrint 4100 printers)
<b>720</b>	720 pels-per-inch (for example, InfoPrint 5000 printers)

**Note:** If you specify a resolution that the printer does not support, the image is printed under most conditions, but with degraded results. Specify the correct resolution for the printer that you will print the PCL job on.

`-w—nnnn.nnnu—`

- Specifies the width of the generated image; *nnnn.nnn* is a number that can optionally contain a decimal point, and *u* is the units in inches (**i**) or millimeters (**m**). If you do not specify a unit (**i** or **m**), then **PCL to AFP** uses pels as the unit type. You cannot specify fractional values (that is, you cannot use a decimal point) for pels.

**Note:** If a text margin is already built into the file, try **-w8.5i** to set the width to 8.5 inches.

- For 240-pel resolution printers, values are:

**8.5i** 8.5 inches, the default

**16 to 4080**

The width can be from 16 pels to 4080 pels, 0.065i to 17.002i, or 1.641m to 431.852m. For example, the following are all valid:

`-w 40m`  
`-w 200.5m`  
`-w 13i`  
`-w 3300`

- For 300-pel resolution printers, values are:

**8.5i** 8.5 inches, the default

**16 to 5100**

The width can be from 16 pels to 5100 pels, 0.052i to 17.001i, or 1.313m to 431.842m. For example, the following are all valid:

`-w 40m`  
`-w 200.5m`  
`-w 13i`  
`-w 5000`

- For 480-pel resolution printers, values are:

**8.5i** 8.5 inches, the default

**16 to 8160**

The width can be from 16 pels to 8160 pels, 0.065i to 17.002i, or 1.641m to 431.852m. For example, the following are all valid:

`-w 40m`  
`-w 200.5m`  
`-w 13i`  
`-w 6600`

- For 600-pel resolution printers, values are:

**8.5i** 8.5 inches, the default

**16 to 10200**

The width can be from 16 pels to 10200 pels, 0.052i to 17.001i, or 1.313m to 431.842m. For example, the following are all valid:

`-w 40m`  
`-w 200.5m`  
`-w 13i`  
`-w 10000`

`-x—nnnn.nnnu—`

- Specifies an X offset (horizontal offset) of the generated image; *nnnn.nnn* is a number that can optionally contain a decimal point, and *u* is the units in inches (i) or millimeters (m). If you do not specify a unit (i or m), then **PCL to AFP** uses pels as the unit type. You cannot specify fractional values (that is, you cannot use a decimal point) for pels.
- An offset value specifies a border or margin around the generated image to avoid the non-printable areas of some printers. An X-offset value specifies the left and right margins of the generated image.
- For all printers, values are:

**0.167i** 0.167 inches, the default

**0 to 8.5i**

The X offset must be less than half of the width (-w) of the generated image. For example, if you specify a width of 13i, then the X offset can be no larger than 6.5i.

**Note:**

1. The X offset specified with **-x** must be less than half of the width specified with **-w**. If the **-x** value is greater than or equal to the **-w** value, a blank page is printed.
2. The X-offset value specifies margins on *both* the left and right sides of the page. If you have a width of 8.5 inches and specify an X offset of 5 inches, a blank page will also result because the margins on the left and right sides of the paper exceed the width of the paper.
3. PCL processing is slower when you use the **-x** flag.

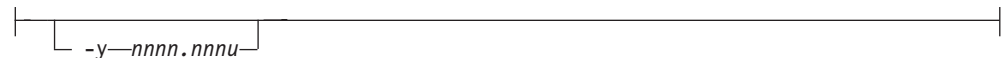

- Specifies a Y offset (vertical offset) of the generated image; *nnnn.nnn* is a number that can optionally contain a decimal point, and *u* is the units in inches (i) or millimeters (m). If you do not specify a unit (i or m), then **PCL to AFP** uses pels as the unit type. You cannot specify fractional values (that is, you cannot use a decimal point) for pels.
- An offset value specifies a border or margin around the generated image to avoid the non-printable areas of some printers. A Y-offset value specifies the top and bottom margins of the generated image.
- For all printers, values are:

**0.167i** 0.167 inches, the default

**0 to 8.5i**

The Y offset must be less than half of the length (-l) of the generated image. For example, if you specify a length of 14i, then the Y offset can be no larger than 7.0i.

**Note:**

1. The Y offset specified with **-y** must be less than half of the length specified with **-l**. If the **-y** value is greater than or equal to the **-l** value, a blank page is printed.
2. The Y-offset value specifies margins on *both* the top and bottom edges of the page. If you have a length of 11 inches and specify an Y offset of 6 inches, a blank page will also result because the margins on the top and bottom of the paper exceed the length of the paper.

3. PCL processing is slower when you use the **-y** flag.

### Transforming PCL image data

The output of the **PCL to AFP** transform is AFP image data for any type of PCL input, whether it is text or images. The image created by the **PCL to AFP** transform minimizes white space within an image block by defining the image block size to be exactly the right size to contain all of the black pels of the image. A PCL image might not print if any part of the image lies outside of the valid printable area. In addition, be aware that using form definitions that specify a non-zero logical page origin might move a valid PCL image out of the printable area; thus, the image won't print.

The **PCL to AFP** transform lets you specify the length and the width of PCL images. Before you use the **-l** and **-w** flags of the **PCL to AFP** transform, it's helpful to understand how PCL images are placed on the page.

Figure 2 shows an example of a PCL image. This image is 8.5 inches high and 11 inches wide, measured from the lower-left corner of the image.

If you want to print the entire image, specify a length of 11i and a width of 8.5i. When the image is printed, the upper-left corner of the image is placed at the point on the page called the logical page origin, which is specified in the form definition. The logical page origin is the point on the form where the page of data is positioned, and it is specified as an offset from the top-left corner of the sheet. Therefore, if the form definition has a logical page origin of 0.165 inches from both the left and top sides of the sheet, then the top-left corner of the image is placed 0.165 inches down and to the left of the upper left corner of the sheet.

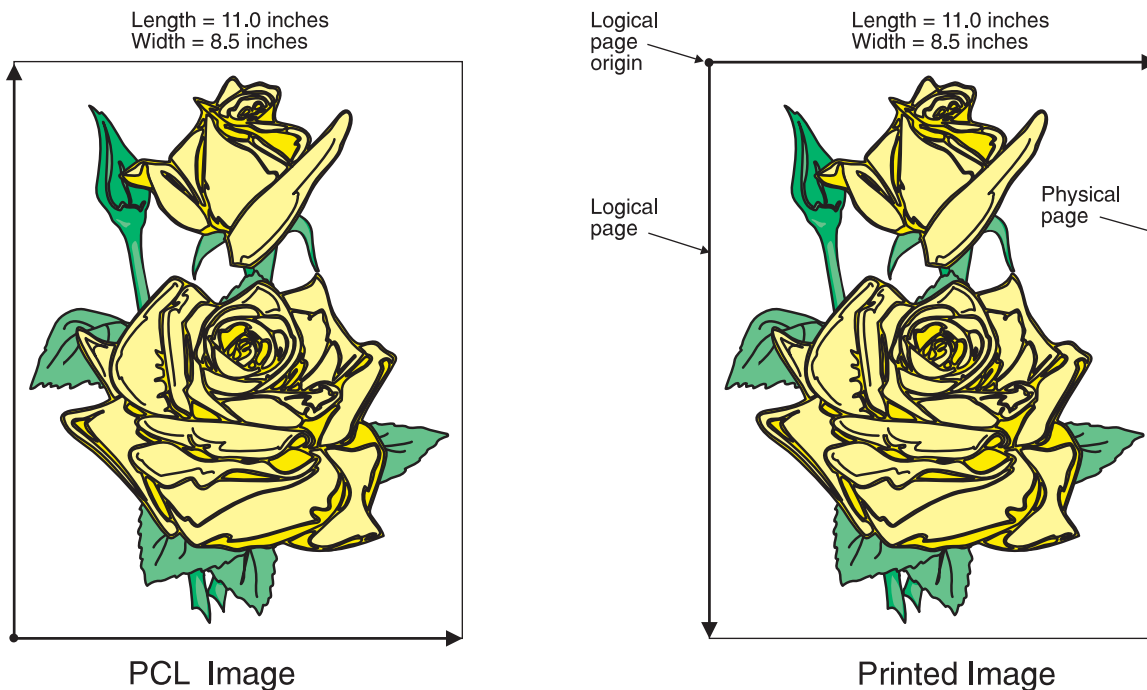

Figure 2. A PCL image

All this gets more complicated if you don't specify the entire image. For example, if you want to crop the image so that you only use the lower left corner, you would



specify a width of 7i and a length of 7i with the **PCL to AFP** transform. The upper left corner of the resulting image is then placed at the logical page origin (Figure 3).

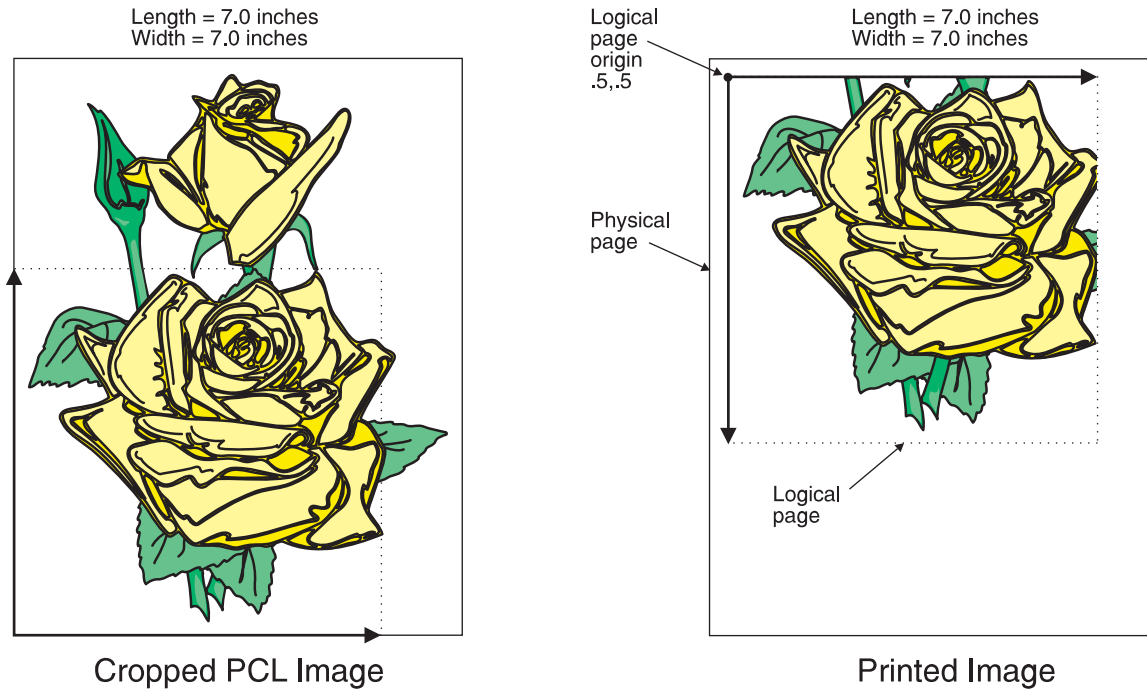

Figure 3. A cropped PCL image

In this example, specify a PCL image that is 8.5 inches wide and 11 inches high. Again, the upper-left corner of the transformed image is placed at the logical page origin. Unless you specify a form definition with the print job that has a zero logical page origin (for example, **F100S**, **F100D**, or **F100T**), the page will not print because part of the image is outside the valid printable area (Figure 4 on page 82).

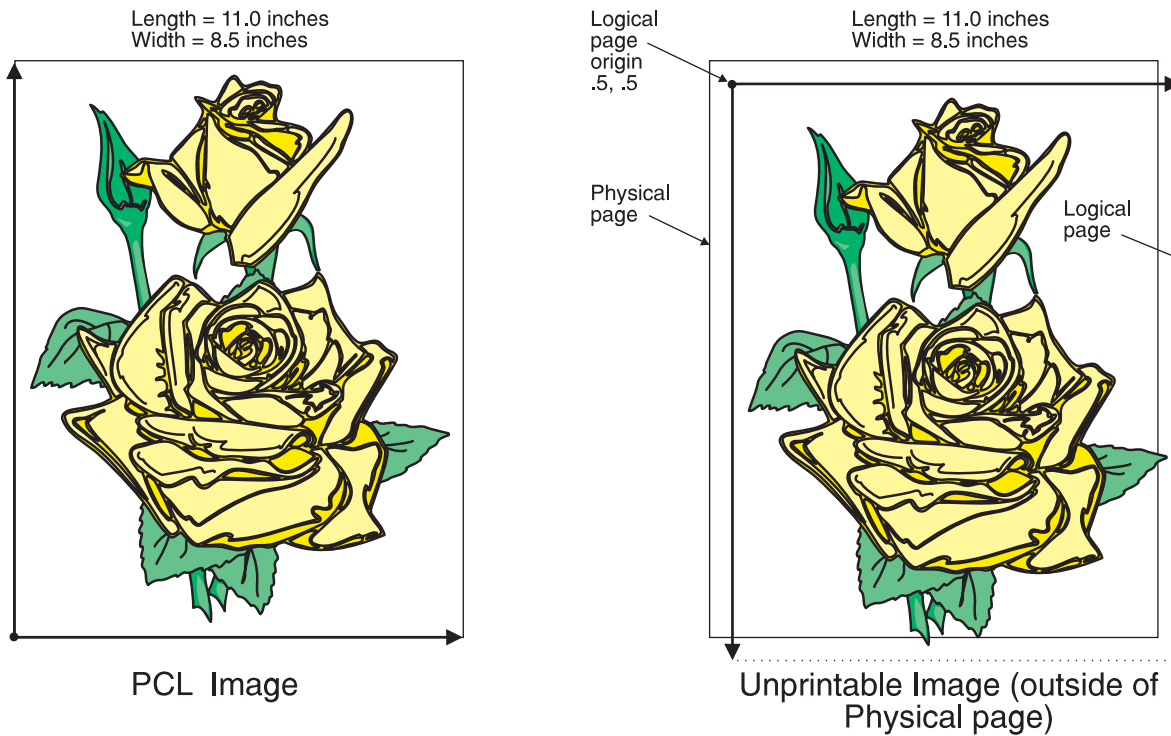

Figure 4. A PCL image offset from the top-left corner

As you can see from Figure 4, specifying the correct form definition is extremely important, particularly when you are printing a full-page image.

The default length and width values work with the default form definitions that are available for each type of printer.

However, if you want to specify exact placement of your PCL output on the page using a zero vertical and horizontal offset from the top-left corner of the page, specify one of these form definitions:

- **F100S**
- **F100D**
- **F100T**

If you specify a 0 horizontal and vertical offset in the form definition, the image produced by the **PCL to AFP** transform might be printed in the unprintable area of the printer. To avoid printing in the unprintable area, you can specify the **-x** (X offset) and **-y** (Y offset) flags on the **PCL to AFP** transform. These flags add white space to the top and left side of the image produced by the transform, ensuring that no data will print in the unprintable area. For more information about the unprintable area of your printer, refer to *Advanced Function Presentation™: Printer Information*.

## Transform PDF or PostScript data to AFP

This section describes the **PDF to AFP** transform and the **PostScript to AFP** transform. It includes syntax and options and values.

These transforms are described in one section because they share the same program.

## Syntax

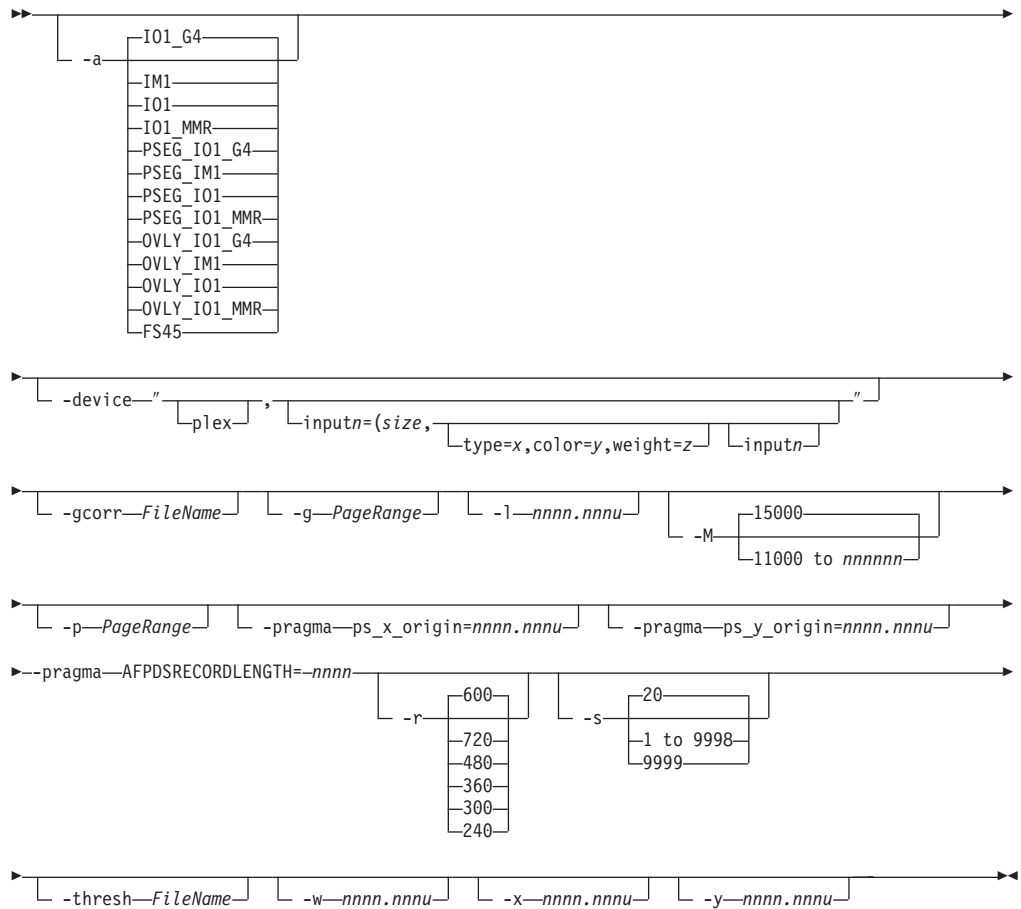

## Description

Use the **PostScript to AFP** transform and the **PDF to AFP** transform, to transform a PostScript or Portable Document Format (PDF) data stream file into an AFP data stream file.

If you specify multiple values of the same flag, **PostScript to AFP** uses the last value specified, with the exception of the **-g** and **-p** flags. Multiple values of the **-g** and **-p** flags are accumulated and the pages identified for printing are printed in normal numerical sequence, regardless of the order you specify.

**Note:** If the transforms fail because of missing fonts, you can use the **Set Transform Server properties** page to turn on font substitution.

## Limitations

- PostScript data can contain device commands (for example, to begin or end duplexing or to change the input bin). Because the AFP architecture defines those device functions in a form definition resource instead of the print data, the **PostScript to AFP** transform ignores the device commands in the print data. To access those device functions (such as duplexing and bin selection), you must specify them in the form definition or attributes file, or on a print command, when you print the job.

- Resolution conversion algorithms may yield degraded appearance when used to reduce the resolution of a datastream. For this reason, **PostScript to AFP** might degrade the appearance of higher-resolution datastreams when used with 240-pel printers. You should verify that print fidelity is satisfactory.

## Flags and values

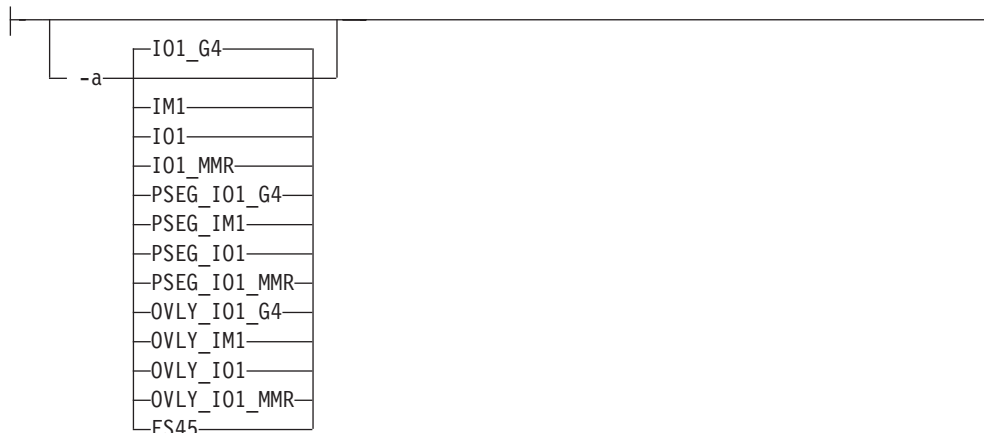

- Determines the type of AFP data stream image to generate for each page in the PostScript or PDF file.

Values are:



- Compressed Image Object Content Architecture (IOCA) image in Modified TSS (formerly CCITT) T.6 G4 Facsimile Coding Scheme (G4 MMR) format. This is the recommended output type because it takes up less space on the fixed disk, and it prints faster.

**Note:** The IBM 3812 and 3816 printers do not support printing with an image type of **IO1\_G4**. For these printers, specify an image type of **IO1\_MMR** because it is the compressed image type supported by these printers. This will result in faster printing than uncompressed image types.

PPDS, PCL, and TCP/IP-attached IPDS printers can print IOCA images; however, only channel-attached printers that have the Advanced Function Image and Graphics (AFIG) feature installed can print IOCA images. Therefore, if you are printing images on channel-attached printers without the AFIG feature, select the **IM1** value.

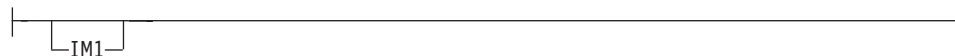

IM1 image. This type of image is not compressed.

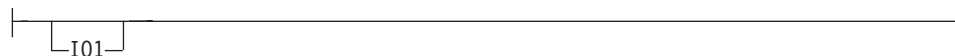

IOCA image. This type of image is not compressed.

I O1\_MMR

Compressed IOCA image in Modified Modified Read (MMR) format.

PSEG\_I01\_G4  
PSEG\_IM1  
PSEG\_I01  
PSEG\_I01\_MMR

- Page segment of the specified image type.

**Note:** When generating page segments from multiple-page documents, you might want to use the **-p** flag to select which page is to be made into a page segment; otherwise, multiple page segments will be created, one for each page of PostScript or PDF.

OVLV\_I01\_G4  
OVLV\_IM1  
OVLV\_I01  
OVLV\_I01\_MMR

- Overlay of the specified image type.

**Note:** When generating overlays from multiple-page documents, you might want to use the **-p** flag to select which page is to be made into an overlay; otherwise, multiple overlays will be created, one for each page of PostScript or PDF.

**FS45** IOCA color format.

**FS45.ovly**

IOCA color format for overlays.

**FS45.pseg**

IOCA color format for page segments.

-device- "plex", inputn=(size, type=x,color=y,weight=z) inputn "

- The **plex** value specifies whether the transform recognizes or honors the plex commands in the data stream, and optionally, specifies how to associate the AFP input tray (**inputn**) with the contents of the output bin. When you specify **inputn**, you must specify **size**, where **size** is a text string like letter, legal, a3, a4, b4, b5, ledger, or a dimension like 8.5x11i. Dimensions can be specified as inches (i), millimeters (m), or points (p). The other three input descriptors (**type**, **color**, and **weight**) are optional, but when you specify them, you must separate them with a comma and no spaces.
- When you do not specify **inputn=...**) with **plex**, plex commands with no additional information for the tray contents are recognized.
- You can specify [**inputn=...**] as many times as you need to.

- The number (*n*) you specify with **input** is the AFP input bin to be selected when the print description language tray selection characteristics are met.
- If you don't specify **plex**, the plex commands in the data stream are ignored.
- If only **input1** is specified, the width (**-w**) and length (**-l**) values must match the size of the media specified for **input1**. For example:

```
ps2afp test.ps -o test.afp -w 210m -l 297m -device 'plex, input1=(a4)'
```

If more than one input is specified, the **-w** and **-l** values must match one of the **input*n*** size specifications. For example:

```
ps2afp test.ps -o test.afp -w 8.5i -l 11i -device 'plex, input1=(letter), input2=(a4)'
```

►► -gcorr—*FileName* ◀◀

- Specifies a *FileName* with a gray scale mapping table for halftoning of the gray scale and color images to bi-level for output. The *FileName* you specify can be a fully qualified filename. If a path is not specified, Transform Manager looks in **/opt/IBM/itm/hn/resources/common/color** on the Linux workstation.
- The mapping table must be provided to compensate for the printing characteristics of the particular output device and paper type, such as dot gain. This file must contain either:
  - 256 real numbers, one for each level of gray in the 8-bit gray scale image
  - The PostScript **settransfer** operator
- The algorithm converts every image to 8-bit gray scale before applying the halftoning algorithm. The default might not produce the halftone image quality that your printer is capable of. Mapping tables for several different engine types and line screens are supplied with Transform Manager and are installed in **/opt/IBM/itm/hn/resources/common/color** on the Linux workstation. To tune your image quality, select the file that matches your printer model. See also options **-alg** and **-thresh**. PostScript code submitted using the **-thresh** option can have the same effect as **-gcorr**.

| -g—*PageRange* |

- Specifies that the output should only contain selected pages. When you specify multiple **-g** flags, the **PostScript to AFP** transforms only the specified pages in the PostScript or PDF input data stream, then prints the transformed pages in normal numerical order, regardless of the order you specify. Examples of values include:
  - g even**  
Output even pages.
  - g odd**  
Output odd pages.
  - g 1-10**  
Output pages 1 through 10.
  - g 10-** Output pages from page 10 until the end of the job.
- You should only specify the **-g** flag when the input data conforms to Adobe Document Structuring Conventions (DSC). If you have any doubt about the input data, use the **-p** flag.
- You cannot specify both the **-g** flag and the **-p** flag.

- You can use **-g** when the **PostScript to AFP** transform is processing one file at a time. This flag is ignored if you specify multiple files within the same job.

```
-l—nnnn.nnnu—
```

- Specifies the length of the generated image; *nnnn.nnn* is a number that can optionally contain a decimal point, and *u* is the units in inches (**i**) or millimeters (**m**). If you do not specify a unit (**i** or **m**), then **PostScript to AFP** uses pels as the unit type. You cannot specify fractional values (that is, you cannot use a decimal point) for pels.

**Note:** If a text margin is already built into the file, try **-l11i** to set the length to 11 inches.

For 240-pel resolution printers, values are:

**11i** 11 inches, the default

**16 to 12720**

The length can be from 16 pels to 12720 pels, 0.065i to 53i, or 1.641m to 1346.2m. For example, the following are all valid:

```
-l 40m
-l 200.5m
-l 13i
-l 4000
```

For 300-pel resolution printers, values are:

**11i** 11 inches, the default

**16 to 15900**

The length can be from 16 pels to 15900 pels, 0.052i to 53i, or 1.313m to 1346.2m. For example, the following are all valid:

```
-l 40m
-l 200.5m
-l 13i
-l 5000
```

For 480-pel resolution printers, values are:

**11i** 11 inches, the default

**16 to 25440**

The length can be from 16 pels to 25440 pels, 0.065i to 53i, or 1.641m to 1346.2m. For example, the following are all valid:

```
-l 40m
-l 200.5m
-l 13i
-l 8000
```

For 600-pel resolution printers, values are:

**11i** 11 inches, the default

**16 to 31800**

The length can be from 16 pels to 31800 pels, 0.052i to 53i, or 1.313m to 1346.2m. For example, the following are all valid:

```
-l 40m
-l 200.5m
-l 13i
-l 10000
```

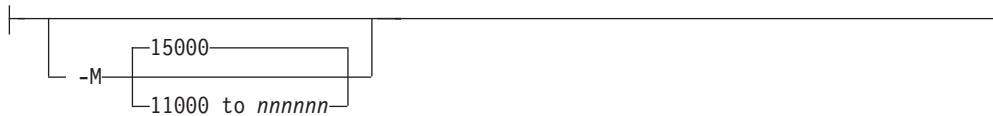

- Determines the maximum amount of memory, in KB, that the transform can use. This flag can be useful if you are processing large PostScript or PDF jobs that require a lot of memory.

Values are:

**15000** 15000KB (15MB)

**11000 to nnnnnn**

The maximum memory ranges from 11000 to *nnnnnn* (where *nnnnnn* is the maximum upper limit the operating system allows) up to 999MB. 15000 is the default.



- Specifies that the output should only contain selected pages. When you specify multiple **-p** flags, the **PostScript to AFP** transforms all the pages in the input, then extracts the specified MO:DCA-P pages and prints them in normal numerical order, regardless of the order you specify.

Examples of values include:

**-p even**

Output even pages.

**-p odd**

Output odd pages.

**-p 1-10**

Output pages 1 through 10.

**-p 10-**

Output pages from page 10 until the end of the job.

- You cannot specify both the **-g** flag and the **-p** flag.
- You can use **-p** when the **PostScript to AFP** transform is processing one file at a time. This flag is ignored if you specify multiple files within the same job.



Specifies an X presentation page origin of the generated image; *nnnn.nnnu* is a number that can optionally contain a decimal point, and *u* is the units in inches (i) or millimeters (m). If you do not specify a unit (i or m), then **PostScript to AFP** uses pels as the unit type. You cannot specify fractional values, that is, you cannot use a decimal point, for pels. If this value is unspecified, zero is presumed.

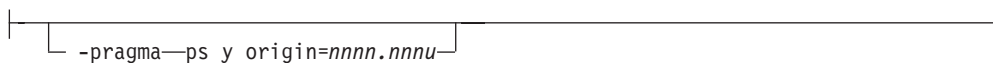

Specifies an Y presentation page origin of the generated image; *nnnn.nnnu* is a number that can optionally contain a decimal point, and *u* is the units in inches (i) or millimeters (m). If you do not specify a unit (i or m), then **PostScript to**



**AFP** uses pels as the unit type. You cannot specify fractional values, that is, you cannot use a decimal point, for pels. If this value is unspecified, zero is presumed.

| `--pragma--AFPDSRECORDLENGTH=nnnnn--` |

Use *nnnnn* to specify the maximum number of bytes in a record. For example, `--pragma AFPDSRECORDLENGTH=8000` limits the record length to 8K.

The default is 32000, and the value range is 8000 to 32000.



- Specifies the resolution of the output image. Select the resolution based on the printer on which you will be printing the image.

Values are:

- 240** 240 pels-per-inch (for example, IBM 3812, 3825, 3827, 3835, and 3900 printers)
- 300** 300 pels-per-inch (for example, IBM 4019, 4028, 4029, and 4039 printers and Hewlett-Packard printers)
- 360** 360 pels-per-inch (for example, InfoPrint 5000 printers)
- 480** 480 pels-per-inch
- 600** 600 pels-per-inch (for example, InfoPrint 4100 printers), the default
- 720** 720 pels-per-inch (for example, InfoPrint 5000 printers)



- Specifies the maximum amount of time, in minutes, that the PostScript interpreter remains idle between jobs before it goes down. When the PostScript interpreter is running, it uses some of the workstation memory.

Values are:

- 20** The default time is 20 minutes.
- 1 to 9998**  
The time is the number of minutes specified in one-minute increments.
- 9999** There is no time limit.



- Specifies a *FileName* that contains a PostScript Type 1 or Type 3 halftone dictionary. The *FileName* you specify can be a fully qualified filename. If a path is not specified, Transform Manager looks in `/opt/IBM/itm/hn/resources/common/color` on the Linux workstation.
- Halftone dictionaries for several different engine types and line screens are supplied with Transform Manager and are installed in `/opt/IBM/itm/hn/resources/common/color` on the Linux workstation. To tune your image quality, select the file that matches your printer model.
- Alternatively, the PostScript code can specify the **setscreen** operator instead of a Type 1 dictionary. The halftone cell in the dictionary is used to overwrite the default ordered dither clustered dot halftone cell. If the PostScript code contains a transfer function, either in the halftone dictionary or specified by the **settransfer** operator, the current grayscale correction curve is overwritten as if **-gcorr** were used.

---

`-w—nnnn.nnnu—`

- Specifies the width of the generated image; *nnnn.nnn* is a number that can optionally contain a decimal point, and *u* is the units in inches (**i**) or millimeters (**m**). If you do not specify a unit (**i** or **m**), then **PostScript to AFP** uses pels as the unit type. You cannot specify fractional values (that is, you cannot use a decimal point) for pels.

**Note:** If a text margin is already built into the file, try **-w8.5i** to set the width to 8.5 inches.

For 240-pel resolution printers, values are:

**8.5i** 8.5 inches, the default

**16 to 10200**

The width can be from 16 pels to 10200 pels, 0.052i to 34i, or 1.313m to 863.628m. For example, the following are all valid:

```
-w 40m
-w 200.5m
-w 13i
-w 5000
```

For 300-pel resolution printers, values are:

**8.5i** 8.5 inches, the default

**16 to 10200**

The width can be from 16 pels to 10200 pels, 0.052i to 34i, or 1.313m to 863.628m. For example, the following are all valid:

```
-w 40m
-w 200.5m
-w 13i
-w 5000
```

For 600-pel resolution printers, values are:

**8.5i** 8.5 inches, the default

**16 to 20400**

The width can be from 16 pels to 20400 pels, 0.052i to 34i, or 1.313m to 863.628m. For example, the following are all valid:

```

-w 40m
-w 200.5m
-w 13i
-w 5000

```

```

-x—nnnn.nnnu

```

- Specifies an X offset (horizontal offset) of the generated image; *nnnn.nnn* is a number that can optionally contain a decimal point, and *u* is the units in inches (**i**) or millimeters (**m**). If you do not specify a unit (**i** or **m**), then **PostScript to AFP** uses pels as the unit type. You cannot specify fractional values (that is, you cannot use a decimal point) for pels.

An offset value specifies a border or margin around the generated image to avoid the non-printable areas of some printers. An X-offset value specifies the left and right margins of the generated image.

Values are:

0 No border is specified. This is the default.

**0 to 17i**

The X offset must be less than half of the width (**-w**) of the generated image. For example, if you specified **-w=12i**, this value can be no greater than 6i.

```

-y—nnnn.nnnu

```

- Specifies a Y offset (vertical offset) of the generated image; *nnnn.nnn* is a number that can optionally contain a decimal point, and *u* is the units in inches (**i**) or millimeters (**m**). If you do not specify a unit (**i** or **m**), then **PostScript to AFP** uses pels as the unit type. You cannot specify fractional values (that is, you cannot use a decimal point) for pels.

An offset value specifies a border or margin around the generated image to avoid the non-printable areas of some printers. A Y-offset value specifies the top and bottom margins of the generated image.

Values are:

0 No border is specified. This is the default.

**0 to 17i**

The Y offset must be less than half of the length (**-l**) of the generated image. For example, if you specified **-l=16i**, this value can be no greater than 8i.

## Transform SAP OTF or ABAP data to AFP

### Syntax

#### sap2afp command

```

▶▶—sap2afp— -d—DeviceName— [-i] [-g] infile [-o—outfile—]

```

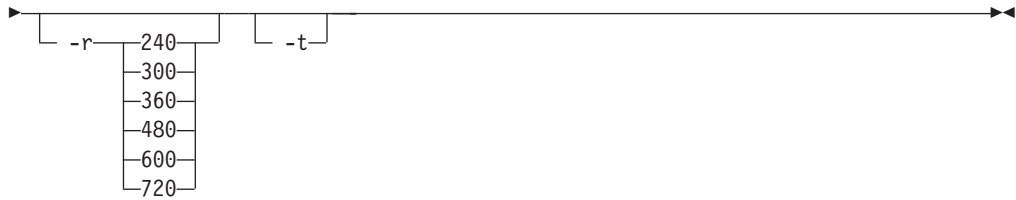

## Description

Use the **sap2afp** command to transform an SAP Output Text Format (OTF) or Advanced Business Application Programming (ABAP) file into an AFP data stream file and to submit it to an InfoPrint destination.

**Note:** The **sap2afp** command supports SAP Unicode OTF data on both AIX and Windows operating systems. Unicode support is implemented only for OTF data. SAP Unicode LIST data is not supported. However, you must obtain and install the AIX, Windows NT/2000, AS/400 AFP Unicode Font PRPQ (5799-GJJ) that is required for printing the unicode fonts from an IBM representative. For more information about unicode support, see the *InfoPrint Manager: SAP R/3 Planning and Configuration Guide*, S550-1051.

## Automatic invocation

The PSF DSS automatically invokes the **sap2afp** transform command whenever you submit a OTF or ABAP file for printing. You can pass options to **sap2afp** using the **other-transform-options** attribute on the **pdpr** command or the **-o** flag of the AIX print commands and the **lprafp** command. You can also pass options to **sap2afp** through InfoPrint Submit Express or InfoPrint Job Ticketer with the Print-on-Demand feature of InfoPrint Manager. Parameters that are not supported, such as **-r 300**, can be passed in InfoPrint Submit Express by clicking on the **Advanced** tab and entering them in the **Transform options** or in InfoPrint Job Ticketer by selecting the **Transform Settings** page and entering them in the **Transform options**.

## Flags

— **-d**—*DeviceName*—

Specifies the name of the R/3 output device. This name is converted to the name of an InfoPrint logical destination as specified in the **printer.tab** configuration file.

— **-f**—*FileName*—

Specifies the input file to be converted. This file is erased after successful conversion.

— **-g**—

Invokes the Graphics Object Content Architecture (GOCA) feature of the printer device. The GOCA feature allows you to print boxes with four different levels of shading, as well as clear and solid boxes.

| |----- i -----|

| | Specifies that input comes from standard input (**stdin**). A temporary file  
| | (**sap2afp.tmp**) is created, processed as with the **-f** parameter, then erased.

| |----- ininfile -----|

| | Specifies the input file to be converted. This file is erased after successful  
| | conversion.

| |----- -o outfile -----|

| | Specifies the output file.

| |----- q -----|

| | Invokes the **lpq** command to display the queue.

| |-----  
| |     ┌ -r 240  
| |     ├ 300  
| |     ├ 360  
| |     ├ 480  
| |     ├ 600  
| |     └ 720  
| |-----

| | Specifies the printer resolution used to print image data in the job. If you do not  
| | specify the **-r** flag, the **DEFRES** value in the **image.tab** file is used.

| |-----  
| |     ┌ -t  
| |-----

| | Traces program execution.

## | | **The sap2afp configuration files**

| | This section consists of examples for the following configuration files that are  
| | required for the **sap2afp** transform:

- | | • **barcode.tab**
- | | • **defcp.tab**
- | | • **fonts.tab**
- | | • **image.tab**
- | | • **pagedef.tab**
- | | • **printer.tab**
- | | • **xxxxyyyy.tab**

### | | **Notes:**

- | | 1. All tables can contain comments (starting with **//** in column 1) and empty  
| | lines. These lines are ignored by the **sap2afp** transform.
- | | 2. All table entries are case-sensitive.

## barcode.tab configuration file

This table describes the bar code mappings. SAP calls bar codes by names that must be mapped into the matching bar codes available with Bar Code Object Content Architecture™ (BCOCA™).

**barcode.tab** uses the following keyword-value pairs:

### BarCode

Specifies the OTF bar code names (**SAPBARCODE** parameter of the **BC** OTF command). The maximum length of this field is 8 bytes. It can contain any value.

**Type** Specifies the AFP bar code type as defined in *IBM Data Stream and Object Architectures: Bar Code Object Content Architecture Reference* for the **Barcode Type** parameter of the **Barcode Data Descriptor** Structured Field. The content can be any decimal value between 0 and 999. The **sap2afp** transform does not verify that this value maps to a valid hexadecimal barcode type.

**Mode** Specifies the modifier byte within the **Barcode Modifier** parameter of the **Barcode Data Descriptor** Structured Field. Any numeric value between 0 and 999 is accepted and not verified.

**Flag** Controls the printing of the Human Readable Interface (**HRI**) character. Specify one of the following values:

**0** Causes the **HRI** character to be printed

**128** Causes the **HRI** character not to be printed

### ModWidth=*n*

This optional keyword specifies the width of the smallest defined bar code element, using mils (thousandths of an inch). For bar code types that explicitly specify the module width, such as POSTNET or RM4SCC, this field is ignored. The range of values allowed is 1–254. If **ModWidth** is not specified, the printer default ModWidth is used.

*n* specifies the width of each module, using thousandths of an inch (1/1000) as the unit of measurement.

### Ratio=*n*

This optional keyword specifies the ratio between the width of the wide and the narrow bar code elements. The range of values allowed is 100–500, but you must specify a value appropriate for your printer and bar code type. If the values you specify are not appropriate for your printer, error messages are issued at printing time. If **Ratio** is not specified, the printer default Ratio is used.

*n* specifies the **Ratio** as a percent value. The ratio value should be between 200 and 300 in the form *n**n**n*. For example, 200 represents a ratio of 2 to 1; 250 represents a ratio of 2.5 to 1. For bar code types that explicitly specify the module width (for example, POSTNET and RM4SCC, this field is ignored. If **RATIO** is not specified, the default ratio for the bar code symbol is used.

**Note:** Many barcode types do not support Ratio values or if they do, the Ratio values are within certain ranges that are type-specific.

The following example uses both the **Ratio** and **ModWidth** optional keywords:

```
BarCode=BC_CD39 Type=001 Mode=001 Flag=128 Ratio=200 ModWidth=10
```

**Notes:**

1. The system administrator is responsible for the values entered in the table. Invalid values are not verified and may result in errors.
2. The second group of bar codes in the **barcode.tab** file (following the blank line) is supported from R/3 Release 3.0A only.
3. Although 2D barcode support has been added to InfoPrint Manager, the system administrator needs to update the `barcode.tab` with the information for 2D barcode for users who need to use them. **How does this apply to ITM and sap2afp?**

Figure 5 on page 96 shows a sample **barcode.tab** configuration file.

```

// Barcode table

// Format : Barcode=ARTNR Type=017 Mode=002

//Barcode = 30F9      Type = 001 Mode = 001 Flag = 000
//Barcode = 30F91    Type = 001 Mode = 002 Flag = 000
//Barcode = MSI      Type = 002 Mode = 002 Flag = 000
//Barcode = UPCA     Type = 003 Mode = 000 Flag = 000
//Barcode = UPCE     Type = 005 Mode = 000 Flag = 000
//Barcode = UPC2     Type = 006 Mode = 000 Flag = 000
//Barcode = UPC5     Type = 007 Mode = 000 Flag = 000
//Barcode = EAN8     Type = 008 Mode = 000 Flag = 000
//Barcode = EAN13    Type = 009 Mode = 000 Flag = 000
//Barcode = IND25    Type = 010 Mode = 002 Flag = 000
//Barcode = MAT25    Type = 011 Mode = 002 Flag = 000
//Barcode = INTER    Type = 012 Mode = 002 Flag = 000
//Barcode = CODA     Type = 013 Mode = 002 Flag = 000
//Barcode = C128     Type = 017 Mode = 002 Flag = 000
//Barcode = EAN2     Type = 022 Mode = 000 Flag = 000
//Barcode = EAN5     Type = 023 Mode = 000 Flag = 000
//Barcode = POST     Type = 024 Mode = 002 Flag = 000
//Barcode = AUFNR    Type = 001 Mode = 001 Flag = 128

Barcode = ARTNR      Type = 017 Mode = 002 Flag = 000
Barcode = AUFNR      Type = 017 Mode = 002 Flag = 000
Barcode = BARCLVS    Type = 001 Mode = 001 Flag = 000

Barcode = BC_C128B   Type = 017 Mode = 002 Flag = 128
Barcode = BC_CD39    Type = 001 Mode = 001 Flag = 128
Barcode = BC_CD39C   Type = 001 Mode = 002 Flag = 128
Barcode = BC_EAN13   Type = 009 Mode = 000 Flag = 128
Barcode = BC_EAN8    Type = 008 Mode = 000 Flag = 128
Barcode = BC_I25     Type = 012 Mode = 001 Flag = 128
Barcode = BC_I25C    Type = 012 Mode = 002 Flag = 128
Barcode = BC_MSI     Type = 002 Mode = 001 Flag = 128
Barcode = BC_MSIC    Type = 002 Mode = 002 Flag = 128
Barcode = BC_MSIC1   Type = 002 Mode = 003 Flag = 128
Barcode = BC_MSIC2   Type = 002 Mode = 005 Flag = 128

Barcode = KUNAUNR    Type = 017 Mode = 002 Flag = 000
Barcode = KUNAUPS    Type = 017 Mode = 002 Flag = 000
Barcode = MBBARC     Type = 017 Mode = 002 Flag = 000
Barcode = MBBARC1    Type = 008 Mode = 000 Flag = 000
Barcode = RSNUM      Type = 017 Mode = 002 Flag = 000
Barcode = RSPOS      Type = 017 Mode = 002 Flag = 000
Barcode = RUECKNR    Type = 017 Mode = 002 Flag = 000

```

Figure 5. Sample barcode.tab configuration file

### defcp.tab configuration file

Figure 6 on page 97 shows the default conversion table for the conversion of ASCII characters into EBCDIC. The **sap2afp** transform uses this table for ABAP data conversion.

The left column consists of the ASCII code, while the right column contains the corresponding EBCDIC value. The values are checked for a decimal numeric value between 0 and 255.



```

// Linedata CodePage
//-----
// This file is used internally by sap2afp, as well as
// to convert ABAP data to linedata.

// Format : Ascii=Ebcdic

// T1000819 + box characters -> T1DABASE

000 = 064
001 = 064
002 = 064
.
253 = 064
254 = 062
255 = 223

```

Figure 6. Sample defcp.tab configuration file

### fonts.tab configuration file

This table maps the fonts used in the OTF data stream to AFP fonts.

The following font families are predefined with R/3:

**FONTFAMILY**  
**Font**

**COURIER**  
Courier

**HELVE**  
Helvetica

**LETGOTH**  
Letter Gothic

**LNPRINT**  
Line Print

**TIMES**  
Times New Roman

**OCRA** Optical Character Recognition A

**OCRB** Optical Character Recognition B

**JPMINCHO**  
Heisei Mincho

**DBMINCHO**  
Heisei Mincho

**DBGOTHIC**  
Heisei Gothic

**Note:** **JPMINCHO** and **DBMINCHO** are different names for the same font.

A font named **BARCODE** must be defined for the **HRI** character of a bar code.

The following parameters in the **fonts.tab** configuration file set the format of the fonts you use to print with R/3:

| **DefCodePage**

| Specifies the default SBCS code page used if no **FC** OTF command is  
| given or if the requested font is not found in the **fonts.tab** table.

| **DefCharSet**

| Specifies the default SBCS character set used if no **FC** OTF command is  
| given or if the requested font is not found in the **fonts.tab** table.

| **DBDefCodePage**

| Specifies the default DBCS code page used if no **FC** OTF command is  
| given or if the requested font is not found in the **fonts.tab** table.

| **DBDefCharSet**

| Specifies the default DBCS character set used if no **FC** OTF command is  
| given or if the requested font is not found in the **fonts.tab** table.

| **SBDefCodePage**

| Specifies the default SBCS code page used for half-width characters in  
| DBCS fonts if no **FC** OTF command is given or if the requested font is not  
| found in the **fonts.tab** table.

| **SBDefCharSet**

| Specifies the default SBCS character set used for half-width characters in  
| DBCS fonts if no **FC** OTF command is given or if the requested font is not  
| found in the **fonts.tab** table.

| **Font** Describes the font family (**FONTFAMILY** parameter of the **FC** OTF  
| command). The maximum size is 8 bytes and content is not verified.

| **Size** Specifies the font size in 1/10 of a point (**FONT SIZE** parameter of the **FC**  
| OTF command). The value must be numeric and is not verified.

| **Type** Defines the font type (**BOLD** and **ITALIC** parameter of the **FC** OTF  
| command). **Type=0** is normal, **Type=1** is italic, **Type=2** is bold, and **Type=3**  
| is italic bold. Any other value is invalid.

| **CodePage**

| Specifies the code page and requires a valid AFP code page name (8  
| bytes). The value is not verified. An invalid name can result in an error  
| message.

| **CharSet**

| Specifies the AFP font character set. The content is not verified.

| **CodedFont**

| Specifies the AFP coded font. The content is not verified.

| **DB** Specifies whether the font is an SBCS font (**DB=0**) or a DBCS font (**DB=1**).

| **SBCodePage**

| Specifies the single-byte code page used for half-width characters in DBCS  
| fonts. The value is not verified. An invalid name can result in an error  
| message.

| **SBCharSet**

| Specifies the AFP single-byte font character set used for half-width  
| characters in DBCS fonts. The content is not verified.

| **SBCodedFont**

| Specifies the AFP single-byte coded font used for half-width characters in  
| DBCS fonts. The content is not verified.

If an SBCS font that matches the **Font**, **Size** and **Type** values is not found, the code page and font character set from the **DefCodePage** and **DefCharSet** keywords are used and a warning message is displayed. If a DBCS font that matches the **Font**, **Size** and **Type** values is not found, the code pages and font character sets from the **DBDefCodePage**, **SBDefCodePage**, **DBDefCharSet**, and **SBDefCharSet** keywords are used and a warning message is displayed.

ISO 8859-1 (Latin-1) is the default code page that maps to the **1148** code page in the **fonts.tab** configuration table. This ISO code page maps to the German **T1V10273** code page and must be modified for non-Latin-1 R/3 installations. You can make this change on the **xxxxyyyy.tab** configuration file that is used to convert data from ASCII data to EBCDIC data so that these characters are mapped correctly.

Use the font Letter Gothic Latin1 of the coordinated font family for ABAP listings. If you do not want to install the coordinated font family and plan to use the traditional Gothic text fonts found within the IBM Compatibility Fonts, you can adjust the font names in the **pagedef.tab** configuration file.

If you wish to use fonts that are not supported, take the following steps:

1. Obtain the font as Adobe Type 1.
2. Convert the font into a raster using the Type Transformer in the IBM AFP Font Collection (program number 5648-113) or the Type Transformer in IBM InfoPrint Fonts (5648-E77 for Multiplatforms, such as iSeries™ or Windows).
3. Contact your InfoPrint representative for further details.

Figure 7 on page 100 and Figure 8 on page 100 show examples of sections of the **fonts.tab** configuration file.

```

| // Fonts table
| // Format : Font=COURIER Size=070 Type=0 CodePage=T1V10273 CharSet=C0420070 DB=0
| //           or
| //           Font=COURIER Size=090 Type=0 CodedFont=X0GT2A DB=0
| //           or
| //           Font=JPMINCHO Size=060 Type=0 CodePage=T10300 CharSet=CZJHMN DB=1 SBCodePage=T1H01027 SBCharSet=CZJHMN
| //           or
| //           Font=JPMINCHO Size=060 Type=0 CodedFont=XZJHMN DB=1 SBCodedFont=XZN16J
| DefCodePage = T1V10273
| DefCharSet   = C0420000
| DBDefCodePage = T10300
| DBDefCharSet  = CZJHMN
| SBDefCodePage = T1H01027
| SBDefCharSet  = CZJHMN
|
| // Courier
| Font=COURIER Size=070 Type=0 CodePage=T1V10273 CharSet=C0420070 DB=0
| Font=COURIER Size=070 Type=1 CodePage=T1V10273 CharSet=C0430070 DB=0
| Font=COURIER Size=070 Type=2 CodePage=T1V10273 CharSet=C0440070 DB=0
| Font=COURIER Size=070 Type=3 CodePage=T1V10273 CharSet=C0450070 DB=0
| Font=COURIER Size=080 Type=0 CodePage=T1V10273 CharSet=C0420080 DB=0
| Font=COURIER Size=080 Type=1 CodePage=T1V10273 CharSet=C0430080 DB=0
| Font=COURIER Size=080 Type=2 CodePage=T1V10273 CharSet=C0440080 DB=0
| Font=COURIER Size=080 Type=3 CodePage=T1V10273 CharSet=C0450080 DB=0
| Font=COURIER Size=100 Type=0 CodePage=T1V10273 CharSet=C0420000 DB=0
| Font=COURIER Size=100 Type=1 CodePage=T1V10273 CharSet=C0430000 DB=0
| Font=COURIER Size=100 Type=2 CodePage=T1V10273 CharSet=C0440000 DB=0
| Font=COURIER Size=100 Type=3 CodePage=T1V10273 CharSet=C0450000 DB=0
| Font=COURIER Size=120 Type=0 CodePage=T1V10273 CharSet=C04200B0 DB=0
| Font=COURIER Size=120 Type=1 CodePage=T1V10273 CharSet=C04300B0 DB=0
| Font=COURIER Size=120 Type=2 CodePage=T1V10273 CharSet=C04400B0 DB=0
| Font=COURIER Size=120 Type=3 CodePage=T1V10273 CharSet=C04500B0 DB=0
| Font=COURIER Size=140 Type=0 CodePage=T1V10273 CharSet=C04200D0 DB=0
| Font=COURIER Size=140 Type=1 CodePage=T1V10273 CharSet=C04300D0 DB=0
| Font=COURIER Size=140 Type=2 CodePage=T1V10273 CharSet=C04400D0 DB=0
| Font=COURIER Size=140 Type=3 CodePage=T1V10273 CharSet=C04500D0 DB=0
| Font=COURIER Size=200 Type=0 CodePage=T1V10273 CharSet=C04200J0 DB=0
| Font=COURIER Size=200 Type=1 CodePage=T1V10273 CharSet=C04300J0 DB=0
| Font=COURIER Size=200 Type=2 CodePage=T1V10273 CharSet=C04400J0 DB=0
| Font=COURIER Size=200 Type=3 CodePage=T1V10273 CharSet=C04500J0 DB=0

```

Figure 7. Header and Courier portions of a sample fonts.tab configuration file

```

| // Japanese Gothic
| Font=DBGOTHIC Size=060 Type=0 CodePage=T10300 CharSet=CZJHKG DB=1 SBCodePage=T1H01027 SBCharSet=CZJHKG
| Font=DBGOTHIC Size=080 Type=0 CodePage=T10300 CharSet=CZJHKG DB=1 SBCodePage=T1H01027 SBCharSet=CZJHKG
| Font=DBGOTHIC Size=100 Type=0 CodePage=T10300 CharSet=CZJHKG DB=1 SBCodePage=T1H01027 SBCharSet=CZJHKG
| Font=DBGOTHIC Size=100 Type=1 CodePage=T10300 CharSet=CZJHKG DB=1 SBCodePage=T1H01027 SBCharSet=CZJHKG
| Font=DBGOTHIC Size=120 Type=0 CodePage=T10300 CharSet=CZJHKG DB=1 SBCodePage=T1H01027 SBCharSet=CZJHKG
| Font=DBGOTHIC Size=140 Type=0 CodePage=T10300 CharSet=CZJHKG DB=1 SBCodePage=T1H01027 SBCharSet=CZJHKG
| Font=DBGOTHIC Size=160 Type=0 CodePage=T10300 CharSet=CZJHKG DB=1 SBCodePage=T1H01027 SBCharSet=CZJHKG
| Font=DBGOTHIC Size=180 Type=0 CodePage=T10300 CharSet=CZJHKG DB=1 SBCodePage=T1H01027 SBCharSet=CZJHKG

```

Figure 8. Heisei Gothic portion of a sample fonts.tab configuration file

## image.tab configuration file

This table defines values used to print image data. It contains the following parameters:

### DEFRES

Specifies the default resolution used for printing image data if you do not specify a value for the **-r** flag of the **sap2afp** command. Valid values are **240**, **300**, **480**, and **600**.

**Width** Specifies the width of the dither matrix.

**Height**

Specifies the height of the dither matrix.

**Cell** Specifies the values for the dither matrix.

**Transform**

Specifies 256 grayscale correction values.

Figure 9 shows an example of the **image.tab** configuration file.

```
// image.tab
// from image.tab.851r
//
// This file is used to determine the dither matrix and the
// grayscale correction values.

// Define the default output resolution
DEFRES = 600

// Define the dither matrix
Width = 78
Height = 78
Cell =
  15  63 184 219 249 240 158 109  98  54  82 118 133 113  75  64
  87 104 166 215 234 229 179  62  38  4  15  59 186 220 246 240
166 123  87  61  65 108 133 118  78  64 100 105 167 219 234 230
  :
  28  73 193 223 253 247 199  76  31  8  20  93 148 156 203 178
136 126 144 186 201 155 151  90  43  24  28  75 199 222 254 251
196  79  31  7

//
// Grayscale correction values
//

Transform =
0
1
2
:
248
252
255
```

Figure 9. Sample *image.tab* configuration file

### **pagedef.tab configuration file**

The **pagedef** table provides the **PAGEDEF** and **FORMDEF** values used from the value of the **\*PJPAPER** parameter that is passed to the **sap2afp** transform with any access method that can submit **SAPGOF** to **sap2afp**, including the **E** or **L** access method. It also provides the fonts used for ABAP data.

The name of a **PAGEDEF** for line data is restricted to five digits instead of the usual six characters. The reason for this restriction is that the **PJPAPER** field is twelve bytes long and **must** begin with a **Z**. This restriction applies to ABAP reports (line data) with user-specific formatting only.

**Paper** Specifies the value of the OTF print option parameter **PJPAPER**. The value is not verified.

### FormDef

Specifies the name of the form definition to be used for printing both OTF and ABAP reports. This value is not verified. An error results if the form definition is not found on the print server system.

### PageDef

Specifies the name of the page definition to be used for printing ABAP reports. This value is not verified. An error results if the page definition is not found on the print server system.

### FontNorm

Specifies the normal coded font used for line data printing. The value is not verified.

### FontBold

Specifies the bold coded font used for line data printing. The value is not verified.

Figure 10 shows a sample **pagedef.tab** configuration file:

```
// PageDef table
// Format : Paper=X_65_132 FormDef=F1A10111 PageDef=P1H01SP1
// FontNorm = 50D0 FontBold = 50F0

// Notes:
// =====
// 1) The pagedefs apply to letter size paper.
//    A4 paper size may require modifying the PageDef field.
// 2) Z_INCH12 is a sample for a user specification

Paper=X_65_132 FormDef=F1A10111 PageDef=P1V06683 FontNorm = GB2A FontBold = GB2A
Paper=X_44_120 FormDef=F1A10111 PageDef=P1V06683 FontNorm = GB2A FontBold = GB2A
Paper=X_58_170 FormDef=F1A10111 PageDef=P1V06683 FontNorm = GT8A FontBold = GT8A
Paper=X_65_255 FormDef=F1A10111 PageDef=P1V06683 FontNorm = GT24 FontBold = GT24
Paper=X_65_80 FormDef=F1A10111 PageDef=P1C09182 FontNorm = GT2A FontBold = GB2A
Paper=X_90_120 FormDef=F1A10111 PageDef=P1C09182 FontNorm = GT5A FontBold = GT5A
Paper=X_PAPER FormDef=F1A10111 PageDef=P1C09182 FontNorm = GT2A FontBold = GB2A
// Sample of an added user-defined pagedef entry:
// Paper=Z_INCH12 FormDef=F1SAPFD PageDef=P1SAPPD FontNorm = GT2A FontBold = GB2A
```

Figure 10. Sample **pagedef.tab** configuration file

## printer.tab configuration file

The **printer.tab** configuration file is only needed when you run the **sap2afp** transform standalone; when jobs come from SAP to Transform Manager, the **printer.tab** configuration file is not used. **Is the previous sentence true??** When you use the **-d** flag and before you can transform an R/3 OTF or ABAP-list file, you must map the SAP R/3 device that was used to create it to an InfoPrint logical destination. This is done in the **printer.tab** configuration file that comes with the **sap2afp** transform. **printer.tab** is located in the **/usr/lpp/psf/sap2afp** directory. Because SAP R/3 only passes the short name of the output device (an SAP four-character devices name instead of an InfoPrint Manager logical destination name)**How does this apply to Transform Manager**, the **printer.tab** configuration file allows you to map these names to longer and more meaningful names.

**Note:** If you are using the **-d** flag, you must update the **printer.tab** file every time you want to transform data generated on a new R/3 SAPGOF device.

**printer.tab** uses the following keyword-value pairs:

**Dest** Specifies the four-character name of the R/3 output device. Specify this value for the **-d** flag of the **sap2afp** command.

**System**

Specifies the operating system from which the **sap2afp** output is printed.

**Queue**

Specifies the name of the InfoPrint **How does this apply to Transform Manager???**logical destination.

**Node** Specifies the IP address of the target operating system. The content (a maximum of 15 bytes) is not verified.

**Node** is required for all values of the **System** keyword, but the value is used only when **System=OS/2**.

Figure 11 shows a sample **printer.tab** configuration file. Note that you can include comments in lines preceded by two slashes (**//**).

```
// Printer table
// Format : Dest=SPRT System=AIX Queue=pc14039 Node=192.9.200.220
// Note: The Node parameter is not used for entries where the
// System field is AIX or MVS, but you must still enter a value.
Dest=MVSP System=MVS Queue=pc14039 Node=192.9.200.220
Dest=AIX1 System=AIX Queue=pc14029 Node=192.9.200.116
Dest=AIX2 System=AIX Queue=PSF4039 Node=192.9.200.220
Dest=OS2P System=OS2 Queue=OS2AFP Node=192.9.201.66
Dest=OS2 System=OS2 Queue=OS2AFP Node=192.9.201.66
```

Figure 11. Sample printer.tab configuration file

For example, suppose that you have defined an R/3 AFP printer called **AFPT**. To map **AFPT** to the InfoPrint logical destination **psf3116**, add the following line to **printer.tab**:

```
Dest=AFPT System=AIX Queue=psf3116 Node=0.0.0.0
```

**How does this example apply to Transform Manager?**

**xxxxyyyy.tab configuration file**

These tables are used for the mapping of characters of an individual SAP ASCII code page into an EBCDIC codepage. SAP uses two kinds of code pages: input code pages and output code pages.

SAP provides the the code page configuration files listed in Table 1.

Table 1. SAP code page configuration files

<b>File Name</b>	<b>Input Code Page</b>	<b>Description</b>	<b>Output Code Page</b>	<b>Description</b>
<b>00000000.tab</b>	T1000819	Latin-1 ISO ANSI 8-bit	T1V10273	Germany F.R./Austria-CECP
<b>11000000.tab</b>	T1000819	Latin-1 ISO ANSI 8-bit	T1V10273	Germany F.R./Austria-CECP
<b>40010000.tab</b>	T1000876 <sup>1</sup>	OCR-A ASCII	T1000892	OCR-A
<b>40040000.tab</b>	T1000877 <sup>1</sup>	OCR-B ASCII	T1000893	OCR-B
<b>80000000.tab</b>	IBM-943C	Japanese	IBM-1399-SAP2AFP	Japanese

1. Both the OCR-A and the OCR-B code pages are equivalent to ISO-8859/1 with the special characters **hook**, **fork**, and **chair**.

The file names correspond to the 4-digit value of the **INPUTCODEPAGE** plus the 4-digit value **OUTPUTCODEPAGE** parameter of the **CP** OTF command.

```
// Codepage table

// Inp CodePage 0000
// Out CodePage 0000

// Format : Ascii=Ebcdic

000 = 000
001 = 001
002 = 002
003 = 003
.
253 = 064
254 = 062
255 = 223
```

Figure 12. Sample xxxxyyyy.tab configuration file (single-byte code pages)

```
// Japanese
// SAP2AFP is configured to use IBM-943C-SAP2AFP as the uconv
// "From" value.
// This table sets the "To" value to IBM-1399-SAP2AFP.
//

CONVERT FOR=8000
CONVERT TO=IBM-1399-SAP2AFP
```

Figure 13. Sample xxxxyyyy.tab configuration file (Double-Byte Code Pages)

## Examples

### Transforming and printing a file

This command converts the file **FONTSHP.OTF** and queues the AFP datastream for the destination called **3825**.

```
sap2afp -d 3825 -f FONTSHP.OTF
```

### Transforming and printing from standard input

This command redirects the spooled file **SP11041** to **stdin**, which is read by the **sap2afp** transform. The input from **stdin** is placed in the **sap2afp.tmp** file, which is processed and then erased. AFP data stream output is sent to destination **LPRT**.

```
sap2afp -d LPRT -i < /usr/sap/DEV/DVEBMGS00/SP11041
```

### Tracing the transform

This command converts the file **ANYFILE.OTF** and sends output to destination **3825**. A trace of the execution can be found in the file **sap2afp.trc**, which is placed in the current directory.

```
sap2afp -d 3825 -f ANYFILE.OTF -t
```

## Transform TIFF data to AFP

This section describes the **TIFF to AFP** transform and includes its syntax and options and values.



## Syntax

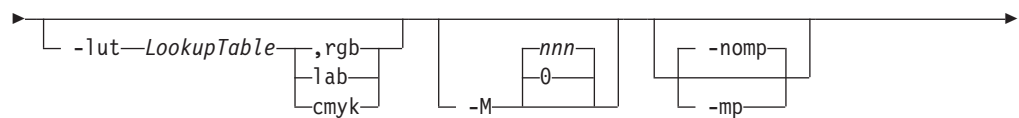
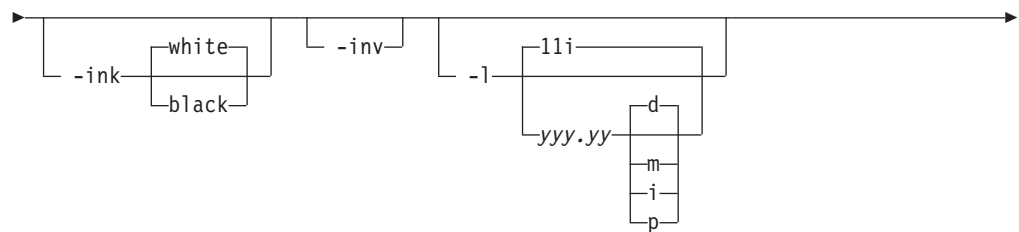
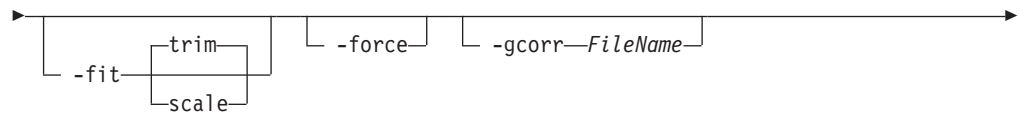
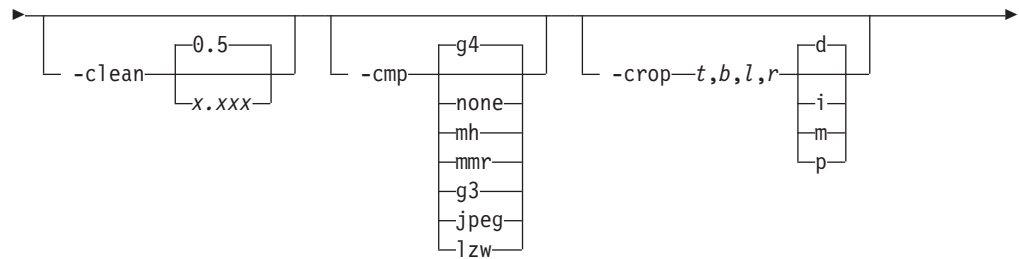
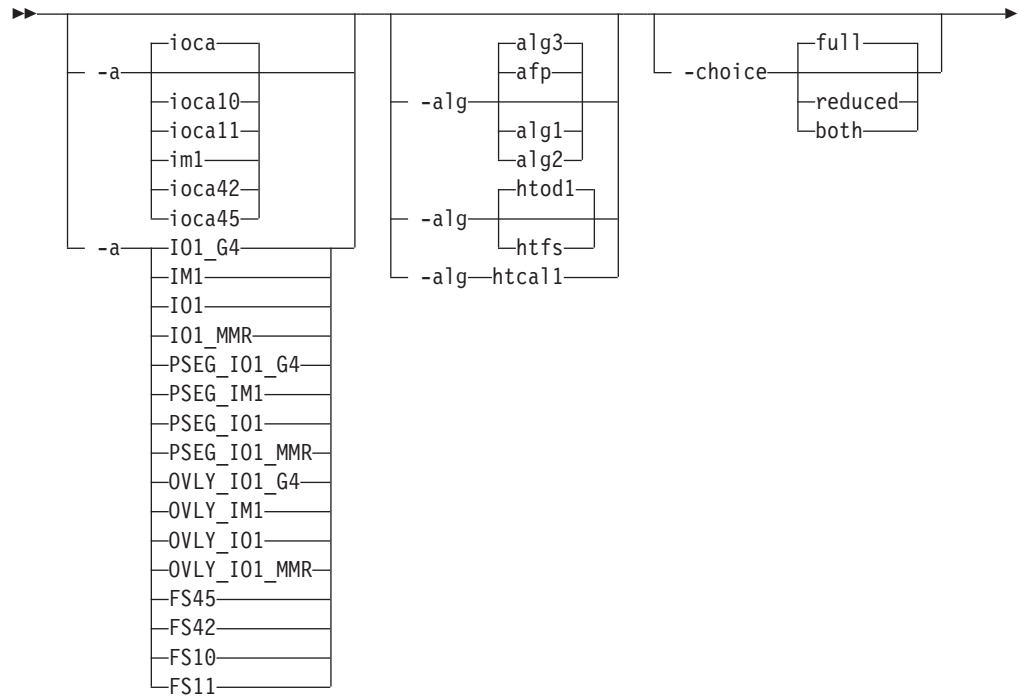

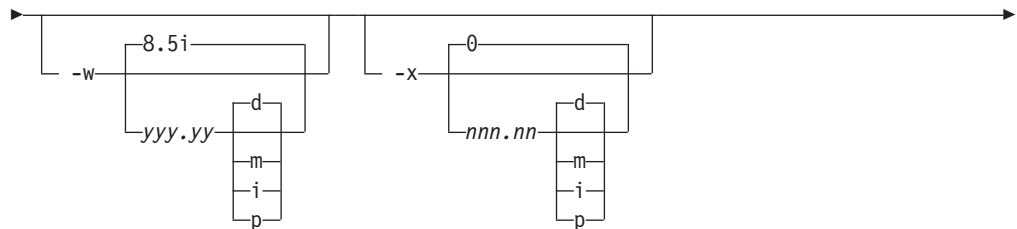
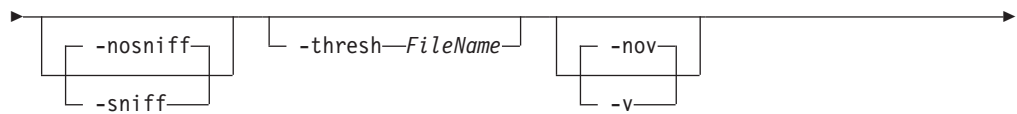
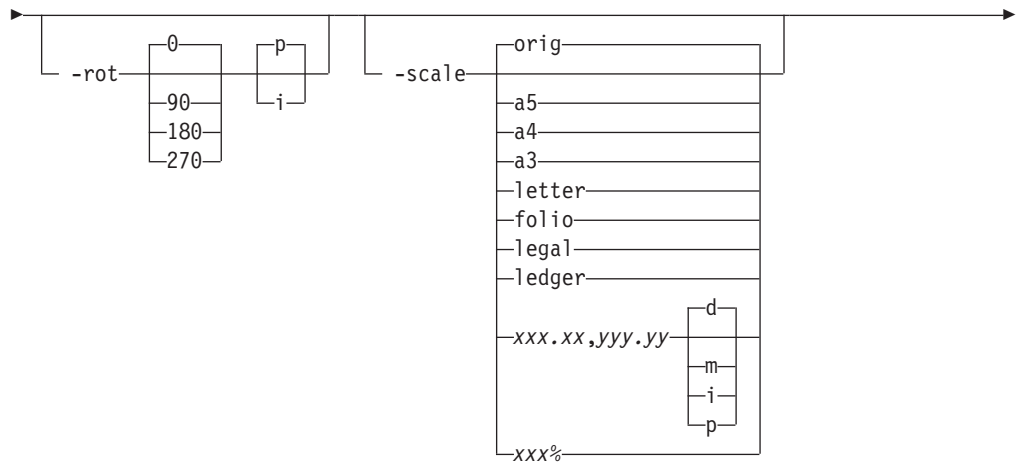
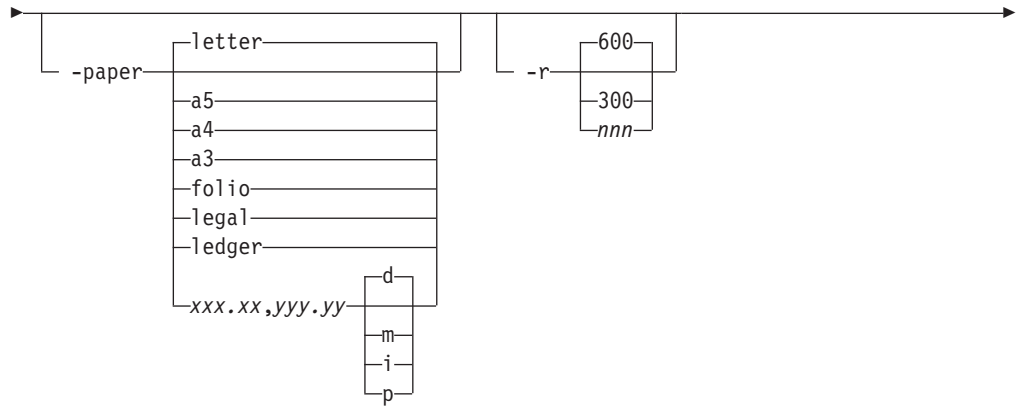
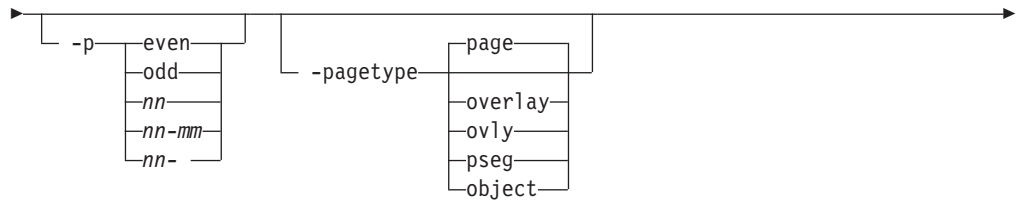
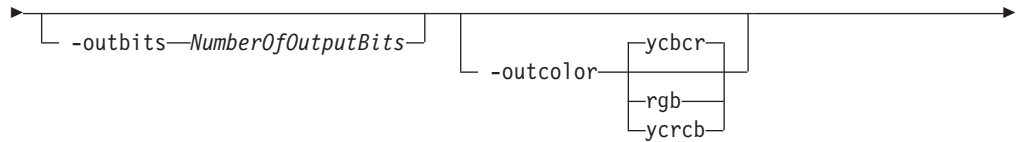



## Description

Use the **TIFF to AFP** transform to transform a TIFF (Tag Image Format File) data stream into an AFP (MO:DCA-P).

The transform can process extended TIFF Revision 6.0 images, including bi-level, gray scale and color images. The output can be bi-level (IM1 or IOCA FS10), 4-bit or 8-bit gray scale, or 24-bit YCbCr color (IOCA FS11), bi-level or 4-bit banded CMYK image at 1-bit per band (IOCA FS42), or a superset of FS42 that also contains 32-bit banded CMYK images, compressed with either JPEG or LZW algorithms (IOCA FS45). The transform automatically uses halftoning to convert the gray scale and color images to bi-level.

## Data transformations

If the input image is gray scale or color, and the output image type is bi-level (for example, IOCA FS10, or IM1), the transform internally scales the image to the desired size, then uses a halftoning algorithm (ordered dither, the default, or Floyd-Steinberg) to convert it to bi-level. In converting the image to bi-level, the characteristics of the output device, such as dot shape and dot gain, must be taken into consideration. The halftone screen and the calibration are extremely printer dependent. While the transform does contain an internal default (85 LPI screen at 45 degrees), an appropriate screen should be used and the halftone should be calibrated properly for best quality.

Some printers, such as the InfoPrint 4000, have two engines, one for each side of the sheet. Each engine commonly has a different calibration. Options **-thresh** and **-gcorr** provide the mechanism to specify halftone screen, grayscale correction curves, and rules for switching calibration based on the engine used to print a particular page. For very light or very dark images, the halftoning algorithms can be automatically recalibrated to preserve detail that would be lost using the default calibration. See option **-alg**.

To maintain the image quality, scaling must be done prior to halftoning. The halftoning algorithm is very compute-intensive. Unless the images are small, **TIFF to AFP** might not be able to process the color images fast enough to feed even a slow printer.

To achieve good image quality for the CMYK output, the input image colors must be converted to CMYK, bearing in mind the characteristics of the particular halftones used to generate the output image. The color conversion is done using a multidimensional lookup table, which is specified with the **-lut** option. If the transform can not determine the appropriate lookup table or the lookup table is missing, a simple conversion of RGB to CMY is performed using the 255- algorithm. This conversion does not use black and generally leads to poor color quality.

The size and the position of the output image on the page depends on several factors. In addition to the size specified to the transform, the result depends on the form map specified at print time and also on the form and options loaded in the printer. If the image is too large to fit on the page, it is trimmed to size by default. Use the **-fit** option to instruct the printer to scale the image to paper size. If the paper size has not been specified explicitly with the **-paper** option, the paper defaults to US letter (8.5 by 11 inches). If the image is larger than this, the paper dimensions are increased as necessary. If the paper size has been specified explicitly, it is not increased if the image will not fit on paper. Options **-l** and **-w** have the same effect as **-paper**.

The size of the actual image, as opposed to the paper size, is controlled by the **-scale** option. The **-scale** option can either specify "**orig**", or give an actual size. If **orig** has been specified, the output image has the same size as the input image. If **-scale** with an actual size has been specified, the output image is scaled to the desired size. A percentage enlargement/reduction can also be specified.

Even if **-scale orig** has been specified, the image may still need to be scaled if the input resolution is different from the output resolution. By default, the transform leaves scaling to the printer. The exceptions are images that are being halftoned, which are always scaled in the transform, and images that have different resolutions on the X and Y directions. The **-alg** option can be used to instruct the transform to perform internal image scaling. Options **-alg**, **-clean**, and **-ink** choose and configure various scaling algorithms used by the transform.

If possible when the input image data matches the output image segments, **TIFF to AFP** just rewraps the TIFF raster data in MODCA-P headers.

The TIFF images are often divided into many segments for efficient memory handling. Some printers will terminate the printing in error if the page is too complex. For that reason, **TIFF to AFP** decompresses, repartitions, and compresses the data if it determines there are too many segments in the picture.

### Limitations

- Only Huffman coding with baseline DCT JPEG algorithm is supported.
- Old style JPEG specification (Photometric Interpretation 6) is not supported. Photometric Interpretation 6 is obsolete and will be removed from the TIFF specification. Use the Photometric Interpretation 7 to incorporate the JPEG compressed images in TIFF files.
- Additional color information, such as alpha data, is disregarded.
- Transparency maps are ignored.
- At most 8-bit gray scale and 24-bit color are supported.

### Acknowledgments

This software is based in part on the work of the Independent JPEG Group.

### Options and values

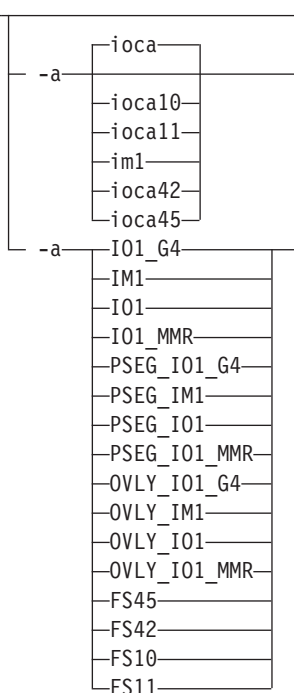

- Choice of the output image type. The first syntax chooses between the IOCA FS 10 (**ioca**, **ioca10**), IOCA FS11 (**ioca11**), IM1, IOCA FS42 (**ioca42**), and IOCA FS45 (**ioca45**) output. IOCA FS10 and IM1 yield bi-level images, while IOCA FS11 results in 4-bit or 8-bit gray or 24-bit color output (see option **-outbits**). Currently, the only product that supports IOCA FS11 is AFP Workbench. IOCA FS42 can contain either bi-level or 4-bit banded CMYK image at 1-bit per band. IOCA FS45 is a superset of FS42 that also contains 32-bit banded CMYK images, compressed with either JPEG or LZW algorithms. The output compression algorithm is set with the **-cmp** option. To set the page type (page, overlay, page segment, or object), use the **-pagetype** option. FS45 produces IOCA FS45 output.
- The second syntax is to maintain compatibility with the **PostScript to AFP** transform, and sets the image type (**IO1** for IOCA FS10 or **IM1** for IM1 output), compression (**G4** for Group 4 or **MMR** for Group 3), and page type (**PSEG** for page segment or **OVLY** for overlay). If **PSEG** or **OVLY** is not specified, the output is a printable page. If no compression algorithm is specified, the output is not compressed. The second syntax cannot be used for IOCA FS11 output.
- Some older printers do not support IOCA images. In such cases, the IM1 output type should be chosen. IM1 images are uncompressed, and thus, use more space. The processing might also take longer since the IM1 image cannot be scaled by the printer, so internal scaling algorithms must be used. See option **-alg**.
- The default is **ioca** for IOCA FS10 output compressed using Group 4 algorithm.



- Choice of the scaling and halftoning algorithms. You can specify multiple choices, separated by commas, for one **-alg** option. The effect is the same as specifying multiple **-alg** options. For example, `-alg htfs,htcal` is equivalent to `-alg htfs -alg htcal`.
- The scaling algorithms are:
  - If **afp** is chosen, the scaling is done using the default algorithm in the printer. This makes the transform much faster. If the image must be reduced, however, this algorithm might drop some information from the image, such as thin lines.
  - **alg1** activates the internal scaling algorithm to scale the image explicitly to the specified size. This algorithm is guaranteed not to discard any ink. “White space” in the image, however, might be lost (that is, features close to one another might merge). This algorithm makes the transform run longer, and might occasionally make for a “dirty” image, since the occasional “noise pixels” in the scanned images tend to be amplified.
  - **alg2** activates the more flexible version of **alg1**. If this algorithm is selected, option **-clean** can be used to specify the amount of ink “cleanup” to be performed. Option **-clean 0.0** makes the algorithm **alg2** perform like **alg1** (albeit more slowly). Increasing the value specified in **-clean** discards more and more ink, until **-clean 1.0** results in a blank page.
  - **alg3** activates a scaling algorithm that works by deleting or duplicating rows and columns in the image. This is a fast general-purpose algorithm.
- For bi-level images, the default is **afp** if the output image type is IOCA and **alg3** if the output image type is IM1. For color images with bi-level output, the scaling is always done prior to the halftoning algorithm. If a grayscale or color output is chosen (**-a ioca11**), this option is ignored and the algorithm is set to **afp**.
- The halftoning algorithms are:
  - **htod1** uses an ordered dither with a screen derived from the value of the **-thresh** option. The default is an 85 line per inch screen.
  - **htfs** uses the Floyd-Steinberg algorithm.
  - **htcal1** recalibrates the halftoning algorithm for each image. **htcal1** forces the transform to read the whole image into memory and requires an additional pass through the image. It should be used only for very light or very dark images.
- The default is **htod1**. Each halftoning algorithm uses a different internal default calibration curve. If the automatic calibration is turned on, a different set of calibration curves is used.
- See options **-clean**, **-gcorr**, **-ink**, **-paper**, **-scale**, **-thresh**, **-l**, **-w**, **-x**, and **-y**.



- TIFF image files can contain both full and reduced resolution versions of each image. The transform can output both versions, or full resolution only, or reduced resolution only, depending on the value for this option. The default is to output the full resolution images only.
- See the **-mp** and **-nomp** options.



- The internal scaling algorithm **alg2** allows for variable thresholding. The scaled pixel is declared painted if the fraction of its area greater than the threshold is painted in the original image. The value *x.xxx* is a real number between zero and 1 inclusive and gives this threshold.
- If the option **-clean 0.0** is issued, **alg2** behaves like **alg1** and turns on a pixel as long as any part of the pixel has been painted in the original image. **-clean 1.0** results in a blank image because the output pixels are never painted.
- The setting **-clean 0.95** and **0.9999999** turns on the pixels that had essentially all the area painted in the original picture. Depending on the data, most of the image will probably be preserved. Increasing **-clean** by a small amount to **1.0** erases the image. If the scaling algorithm is not **alg2**, this option is ignored. The default is **-clean 0.5**.



- Choice of the output image compression algorithm:
  - none** Uncompressed output
  - mh** ITU-T T.4 G3 Modified Huffman
  - mmr** IBM Modified Modified Read
  - g3** ITU-T T.4 G3 Modified Read
  - g4** ITU-T T.6 G4
  - jpeg** JPEG non-differential Huffman coding with baseline DCT. The output image data should be compressed to reduce the file sizes and increase the printing speed.
  - lzw** If **lzw** is specified, linework of 600 dpi is produced; otherwise, lossy JPEG at 300 dpi is produced. **lzw** only applies to FS45.

The default compression is ITU-T T.6 Group 4 for bi-level images and no compression for gray scale or color images. Some printers might not support Group 4 compression algorithm and require using the **-cmp** option to choose a different one. The JPEG algorithm can compress only 8-bit gray scale and 24-bit color images. 4-bit grayscale images cannot be compressed.

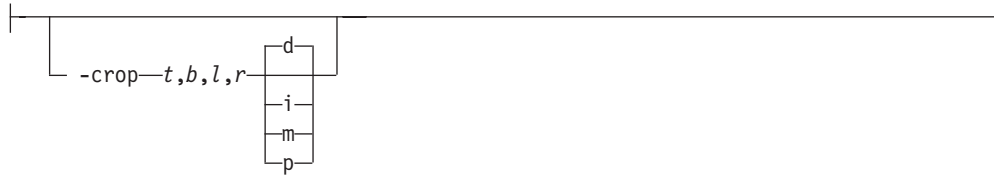

- Image cropping. *t,b,l,r* specify how much should be cropped from the image top, bottom, left edge, and right edge. The numbers are floating point and can be either positive or negative. Negative numbers indicate that a blank space should be inserted. The units are inches, millimeters, points, and dots (pels). The default is dots. The cropping is specified in the context of the output page, so that “top” means the top of the output page and so on, regardless of the **-rot** option. To crop, the transform enlarges the image by the amount to be cropped, then crops the specified amount by manipulating the actual bitmap. The resulting image has the size as specified by the explicit (or implicit) **-scale** option. See also option **-j**.
- If **-fit trim** is specified, the right and the bottom edge of the image are not cropped. Instead, the image grows as necessary. Because **-fit trim** causes the output data stream to contain the “position and trim” specification, the printer discards any extra image.



Determines whether the printer behavior will be position-and-trim or scale-to-fit if the image is too large to fit on the paper. The default is **trim**.

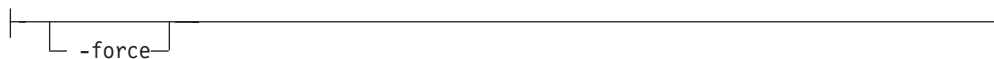

If present, this option forces **TIFF to AFP** to decompress and recompress the image, regardless of other factors.

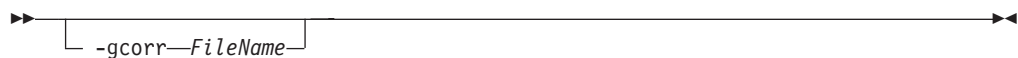

- Specifies a *FileName* with a gray scale mapping table for halftoning of the gray scale and color images to bi-level for output. The *FileName* you specify can be a fully qualified filename. If a path is not specified, Transform Manager looks in `/opt/IBM/itm/hn/resources/common/color` on the Linux workstation.
- The mapping table must be provided to compensate for the printing characteristics of the particular output device and paper type, such as dot gain. This file must contain either:
  - 256 real numbers, one for each level of gray in the 8-bit gray scale image
  - The PostScript **settransfer** operator



- The algorithm converts every image to 8-bit gray scale before applying the halftoning algorithm. The default might not produce the halftone image quality that your printer is capable of. Mapping tables for several different engine types and line screens are supplied with Transform Manager and are installed in `/opt/IBM/itm/hn/resources/common/color` on the Linux workstation. To tune your image quality, select the file that matches your printer model. See also options `-alg` and `-thresh`. PostScript code submitted using the `-thresh` option can have the same effect as `-gcorr`.



- This option is used only with scaling algorithm `alg1` or `alg2`. The TIFF images can be either black on white or white on black. The internal scaling algorithm must know which, because “ink” is preserved at the expense of “non-ink”. The default value, “black”, indicates that the image is black on white.
- If the option `-inv` is used to print the reversed image, the inversion is done as the data is read by the transform, before any processing is done. The black or white must thus be specified in the terms of the printed image, not in the terms of the input TIFF image.



Reverses the image. Areas that are black in the original image become white and vice versa. The reversed image might be either black on white or white on black, depending on the original image.

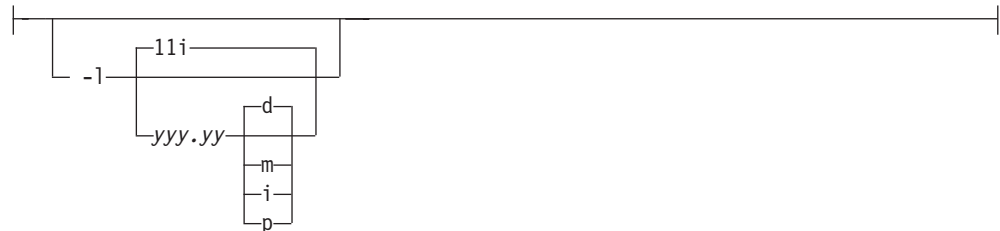

Specifies the paper length. The optional units are **dots** (pels), **millimeters**, **inches**, or **points**. The default unit is dots. If the unit is dots, decimals (if any) are ignored. The default paper length is 11 inches. See options `-w` to set the paper width or `-paper` to set both dimensions at the same time.



- Specifies the *FileName* for the color conversion lookup table file. The *FileName* you specify can be a fully qualified filename. If a path is not specified, Transform Manager looks in `/opt/IBM/itm/hn/resources/common/color` on the Linux workstation.
- Fast and accurate conversion between color spaces can be implemented as a multidimensional lookup with an interpolation algorithm for missing nodes. The

file specified with the **-lut** option must contain a valid lookup table for the conversion between the input and output color spaces. The lookup tables currently come in either ASCII (.lut) or binary formats (.lutbin).

If the optional colorspace tag is not provided, the table is assumed to match the input image. If there is a serious mismatch between the table and the image (for example, the table is RGB to CMYK and the input image is CMYK), the **-lut** is ignored for the image. Otherwise, it is used to convert the colors and any mismatch (for example, using a **lab** table for **rgb** data) results in corrupted output.

If the colorspace tag is provided, then the transform uses the lookup table only for the relevant colorspace image. Multiple **lut** tables can be specified if the user is unsure of the input colorspace. If the **lut** files are binary, parsing extra files does not impose much of a performance penalty.

**Example:**

```
-lut 3170-005.rgb.cmyk.perceptual.lutbin,rgb
```

Where 3170-005 is the model-type; rgb.cmyk is for RGB images; and perceptual is the **color-rendering-intent** value.



Limits the amount of memory available to **TIFF to AFP**. *nnn* is the maximum amount of memory in kilobytes. A value of **0** means there is no memory limit. *nnn* can be set from **0** to the maximum value that the operating system allows. The default is **0**.



Each TIFF image is supposed to have a marker bit set if there are multiple TIFF images in the file. This marker is sometimes missing, even if there are multiple images present in the file. The **-mp** option instructs the transform to behave as if the multipage marker bit were set. The transform then processes all the images in the file, subject to the **-p** and **-choice** options. The default is to leave the marker bit unset (**-nomp**).

**-nomp**

See **-mp**

**-nosniff**

See **-sniff**.

**-nov** See **-v**.

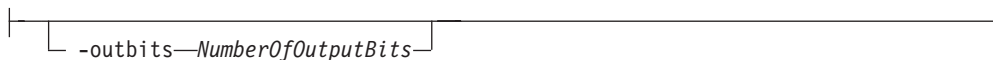

Sets the number of bits per pel in output. This value must be **1**, **4**, **8**, or **24**. If the output image type is IOCA FS10 or IM1, the number of output bits is set to **1** and this option is ignored. For IOCA FS11 output, the default is **24**. This number represents the maximum number of bits used per pel. Thus, even if the number of bits is set to **24**, a 4-bit gray scale image is still displayed in 4-bit format.



Sets the output color model to RGB, YCbCr, or YCrCb if the image type is IOCA FS11 and the number of output bits is 24. Otherwise, this option is ignored. The default is **ycbcr**.



- Specifies that the output should only contain the specified pages. If no **-p** option is given, all the pages are output (but see the **-choice** option for printing full or reduced resolution images of each page). Multiple **-p** options can be specified. Their effect is cumulative. Regardless of the order in which the pages are specified, they are always printed in ascending order.
- The recognized values are:
  - even** Print all even pages
  - odd** Print all odd pages
  - nn* Print page *nn*
  - nn-mm* Print pages *nn* to *mm*, inclusive
  - nn-* Print all pages starting with page *nn*
- Pages are numbered starting with 1.

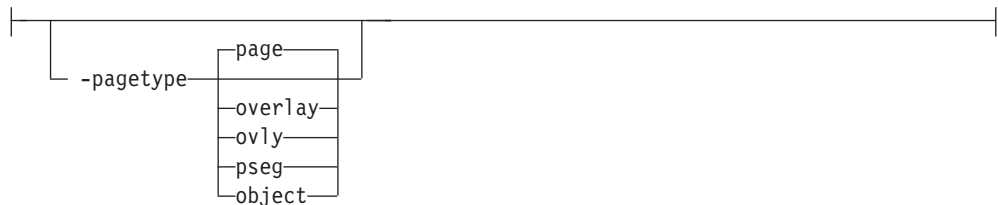

Sets the output page type to be page, overlay, page segment or object. The same page type is set for every page in the output. Thus, unless option **-p** is used to select a single page, multiple page segments or overlays are stored in the output file. The default is **page**. See option **-a**.

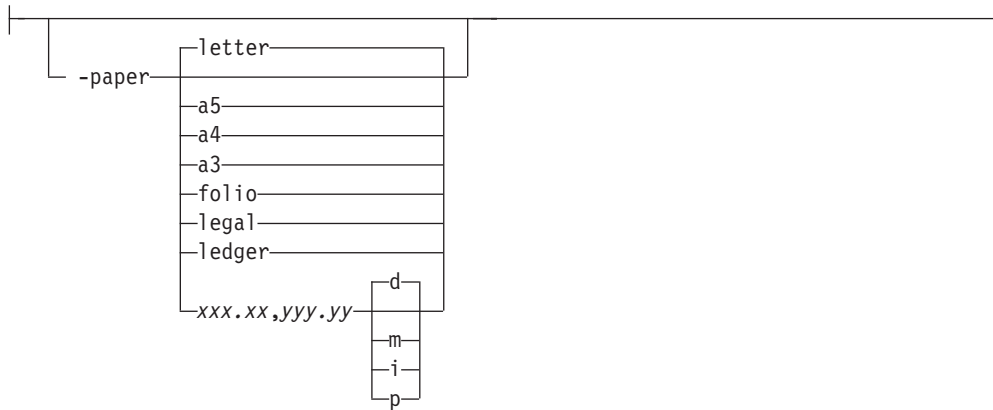

- Specifies the output paper size. The supported values are:
  - a3** A3 format (297 by 420 mm or 11.69 by 16.54 inches)
  - a4** A4 format (210 by 297 mm or 8.27 by 11.69 inches)
  - a5** A5 format (148 by 210 mm or 5.83 by 8.27 inches)
  - letter** 8.5 by 11 inches (216 by 279 mm)
  - folio** 8.5 by 13.0 inches (216 by 330 mm)
  - legal** 8.5 by 14.0 inches (216 by 356 mm)
  - ledger** 11.0 by 17.0 inches (279 by 432 mm)

`xxx.xx,yyy.yy`

Horizontal and vertical image dimensions. The optional units are **d**ots (pels), **m**illimeters, **i**nches, or **p**oints.

- The default paper size is letter. If **-paper** is not used, the paper size is increased, if necessary, to contain the output image.
- See options **-l**, **-w**, and **-scale**.



The output device resolution, specified in dots per inch. The default is **600**.



- The image is rotated in the clockwise direction by the amount specified. The default is zero, that is, no rotation.
- If **p** is specified, the transform sets the output datastream in such a way that the printer performs the actual image rotation. If **i** is specified, the transform rotates the output bitmap. When **i** is chosen, the transform takes much longer to run and uses much more memory. If no letter is specified, the default or any previous value remains in force.

- The default is **p**.

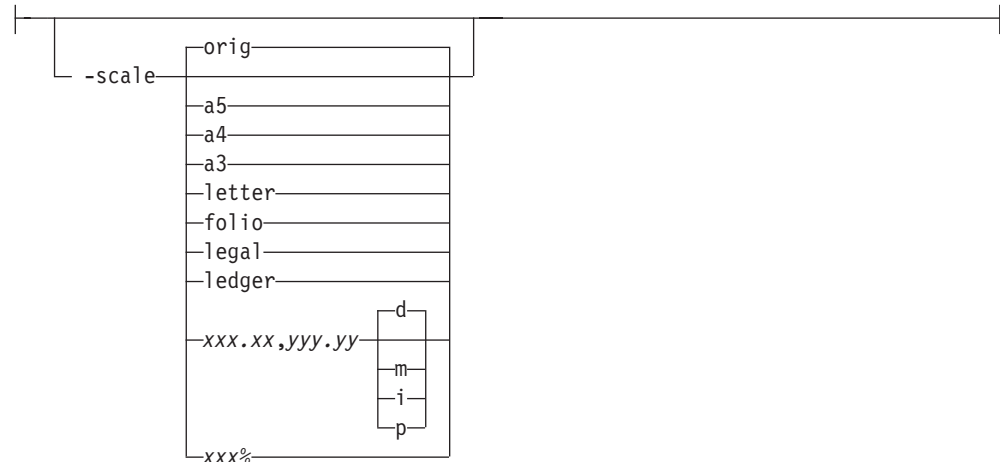

- Specifies the output image size. The image is scaled to this size and centered in the area defined by the paper size and margin options. The supported values are:

**orig** Preserve the input image size, regardless of the printable paper area.

**a3** A3 format (297 by 420 mm or 11.69 by 16.54 inches)

**a4** A4 format (210 by 297 mm or 8.27 by 11.69 inches)

**a5** A5 format (148 by 210 mm or 5.83 by 8.27 inches)

**letter** 8.5 by 11 inches (216 by 279 mm)

**folio** 8.5 by 13.0 inches (216 by 330 mm)

**legal** 8.5 by 14.0 inches (216 by 356 mm)

**ledger** 11.0 by 17.0 inches (279 by 432 mm)

`xxx.xx,yyy.yy`

Horizontal and vertical image dimensions. The optional units are **dots** (pels), **millimeters**, **inches**, or **points**.

`xxx%` Magnification relative to the original image size. Numbers below 100% mean reduction, while Numbers above 100% mean enlargement. For example, **-scale 200%** causes the output image to be twice as long and twice as wide as the input image.

- The default image size is **orig**.



- Turns automatic conversion to black on white for bi-level images on (**-sniff**) or off (**-nosniff**). The automatic conversion algorithm counts the number of 0 and 1 bits in the image. If there are fewer zeros, it assumes the printed features are represented by zeros (white on black), and inverts the image to be black on white. The detection and conversion are done after the conversion specified by the Photometric Interpretation tag is applied (if any).
- This option is ignored if the image is not bi-level.

- The default is **-nosniff**.



- Specifies a *FileName* that contains a PostScript Type 1 or Type 3 halftone dictionary. The *FileName* you specify can be a fully qualified filename. If a path is not specified, Transform Manager looks in `/opt/IBM/itm/hn/resources/common/color` on the Linux workstation.
- Halftone dictionaries for several different engine types and line screens are supplied with Transform Manager and are installed in `/opt/IBM/itm/hn/resources/common/color` on the Linux workstation. To tune your image quality, select the file that matches your printer model.
- Alternatively, the PostScript code can specify the **setscreen** operator instead of a Type 1 dictionary. The halftone cell in the dictionary is used to overwrite the default ordered dither clustered dot halftone cell. If the PostScript code contains a transfer function, either in the halftone dictionary or specified by the **settransfer** operator, the current grayscale correction curve is overwritten as if **-gcorr** were used.



- Turns verbose mode on (**-v**) or off (**-nov**).
    - When verbose mode is on, the transform prints a message as it opens each resource file, then echoes the command line, then prints a message for each file name as it is processed.
    - When verbose mode is off, the transform prints only error messages.
- The default is **-nov**.

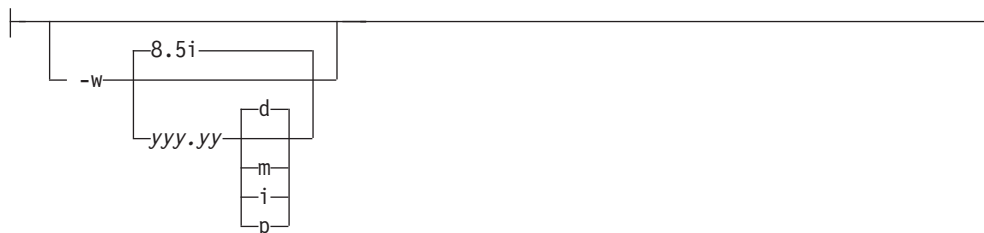

Specifies the paper width. The optional units are **dots** (pels), **millimeters**, **inches**, or **points**. The default unit is dots. The default page width is 8.5 inches. See options **-l** to set the paper length or **-paper** to set both dimensions at the same time.

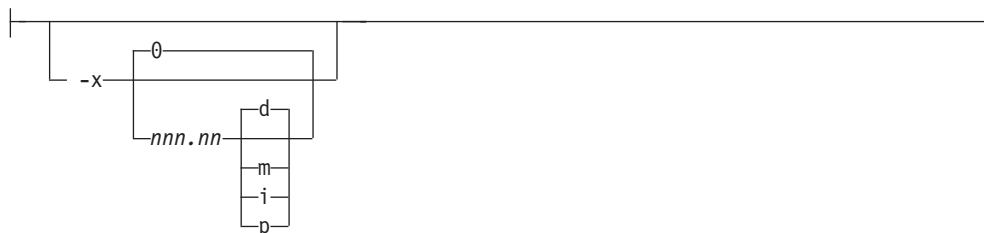

Specifies the left margin. The optional units are **dots** (pels), **millimeters**, **inches**, or **points**. The default unit is dots. The default is zero (no margin).



Specifies the top margin. The optional units are **dots** (pels), **millimeters**, **inches**, or **points**. The default unit is dots. The default is zero (no margin).

## Reading Syntax Diagrams

The syntax for transforms is shown using graphic notation. To read the diagrams, move from left to right and top to bottom, following the main path line.

### Style Rules:

Syntax diagrams use the following style rules to show how to enter commands and parameters:

- A word in uppercase **must** be spelled exactly as shown, but can be coded in any case. For example in coding, FORMDEF or FormDef or formdef are equivalent.
- A word in all italic, lowercase letters shows a parameter that you can replace. For example:

*file\_name*

shows that you replace *file\_name* with a file name that is retained in the library.



- A parameter above the line shows the default parameter. For example, **ioca** is the default parameter in the syntax diagram for the **gif2afp -a**.



### Symbols:

Syntax diagrams use symbols to help you follow the flow of information they communicate:

- Statements begin with:



- and end with:



- Statements longer than one line continue to a second line with:  
→
- Where they resume with:  
▶

### Required Parameters:

A parameter that you must include is displayed on the main path line. For example, the syntax diagram for the **jsmigr** command:



shows that you must follow **jsmigr** with its required parameter.

If there are two or more required parameters from which to choose, the parameters are shown with the first choice on the main path line and the other choices on branch lines under it. For example, the partial syntax diagram for the **gif2adfp** Command with the optional parameter **-cmp**:



shows that you must type the command in any of the following ways:

- **gif2afp -cmp none**
- **gif2afp -cmp mh**
- **gif2afp -cmp mmr**
- **gif2afp -cmp g3**
- **gif2afp -cmp g4**
- **gif2afp -cmp jpeg**

### Optional Parameters:

Parameters that you can include with a command are displayed on the branch line below the main path line.

Branch lines can include branch lines of their own.

### Repeating Parameters:

An arrow on a line above a parameter means that you can either repeat the parameter or enter more than one of the listed parameters.



The arrow above *FileName* means you can include one or more file name parameters with the transform.

## Fragment Elements

A syntax diagram can contain a section that either has too many items or groups to fit in the diagram or is used more than once. This section can be presented as a “fragment”, and given a label that corresponds to the section within the main diagram.

---

## Usage notes for Transform Manager

When you are using two interoperating InfoPrint Transform Manager servers with InfoPrint Manager, set the **maxium-concurrent-jobs** actual destination attribute to 8 to benefit from load balancing. This number needs to be increased as the number of interoperating servers increases.

When you are using InfoPrint ProcessDirector and Infoprint Server for z/OS and you if also need to set an 8K record length, use a pragma with the PCL to AFP, PDF to AFP, and PostScript to AFP transforms. For example, specify **-pragma afpdsrecordlength=8000** on the command line for structured fields to have a maximum length of 8K.

---

## Transform Manager messages

This section lists the Transform Manager messages.

---

**EJZ00175E** The transform server {0} was not updated because you cannot change the Host Name and Port Number while the server is Ready or Transforming.

**Explanation:**

The Host Name and Port Number attributes cannot be changed when the Transform Server is in the Ready or Transforming state.

**System action:**

Processing continues.

**User response:**

To change the Host Name or Port Number, you must stop the Transform Server, change the attributes, and then restart the Transform Server.

---

**EJZ00176E** The transform server {0} was not updated because only the Host Name and Port Number can be changed while the server is Stopped or Lost Connection.

**Explanation:**

Any changes to attributes other than Host Name or Port Number result in an error when the Transform Server is in the Stopped or Lost Connection state because the new values must be passed to the Transform Server to be recognized. Only the Host Name and Port Number attributes can be changed when the Transform Server is in a Stopped or Lost Connection state.

**System action:**

Processing continues.

**User response:**

To change any attributes except Host Name and Port Number, you must start the Transform Server, wait until it is in the Ready or Transforming state, and then make the modifications.

---

**EJZ00177E** The transform server {0} was not updated because you cannot change any attributes while the server is Starting or Stopping.

**Explanation:**

When the Transform Server is in the Starting or Stopping state, it cannot accept any requests from Transform Manager to change attributes. Wait until the Transform Server is Stopped if you want to change the Host Name or Port Number, or wait until the Transform Server is in the Ready or Transforming state to change any of the other attributes.

**System action:**

Processing continues.

**User response:**

To change the Host Name or Port Number, wait until is Transform Server is in the Stopped or Lost Connection state. To change any other attributes, wait until the Transform Server is in the Ready or Transforming state. You may need to start or stop the Transform Server for it to be in the required state.

---

**EJZ00221E** Please use the **Browse...** button to select the resource you want to copy.

**Explanation:**

The user did not select a resource file or entered the path directly instead of using the **Browse...** button.

**System action:**

None.

**User response:**

Use the **Browse...** button to select the resource you want to copy.

---

**EJZ00222E** Transform Manager did not copy the resource file {0} as a {2} resource type for {3} because it could not be uploaded.

**Explanation:**

Transform Manager did not copy the resource file {0} as a {2} resource type for {3} because it could not be uploaded.

**System action:**

None.

**User response:**

Make sure you use the **Browse...** button to select the correct file and try again.

---

**EJZ00223E** Transform Manager received the command to copy the resource file {0} as a {2} resource type for {3} to the following transform servers: *list of servers*.

**Explanation:**

A resource file was sent to the coordinator to be copied to the list of selected Transform Servers.

**System action:**

Processing continues.

**User response:**

None.

---

**EJZ00224E** Transform Manager did not copy the resource file {0} as a {2} resource type for {3} on the Transform Server {1} because the version of this Transform Server is older than 1.2.5 or the communication has been lost.

**Explanation:**

Transform Manager did not copy the resource file {0} as a {2} resource type for {3} on the Transform Server {1} because the version of this Transform Server is older than 1.2.5 or the communication has been lost.

**System action:**

Processing continues.

**User response:**

If the Transform Server is not in Lost Connection state, update the version of Transform Server to 1.2.5.

---

**EJZ00225E** Transform Manager did not copy the resource file {0} as a {2} resource type for {3} on the Transform Server {1} because the coordinator from that machine was down.

**Explanation:**

Transform Manager did not copy the resource file {0} as a {2} resource type for {3} on the Transform Server {1} because the coordinator from that machine was down.

**System action:**

None.

**User response:**

Restart Transform Manager on the Transform Server that reported the error by using the **Restart ITM** button or by rebooting the machine. When the Transform Server is available again, reissue the request.

---

**EJZ00226E** Transform Manager did not copy the resource file {0} as a {2} resource type for {3} on the Transform Server {1} because the user *ibmitm* does not have the required permissions for the target resources directory.

**Explanation:**

Transform Manager did not copy the resource file {0} as a {2} resource type for {3} on the Transform Server {1} because the user *ibmitm* does not have the required permissions for the target resources directory.

**System action:**

The shell script failed to execute a write command (`mkdir`, `cp`) on some resource directory. This situation applies both to the local computer or a compute node from a blade configuration.

**User response:**

If this is a valid request, update the permissions for the target resources directory with these commands:

```
chown -R ibmitm.itm /opt/IBM/itm/xforms
chmod -R u+rwx /opt/IBM/itm/xforms
```

---

**EJZ00227E** Transform Manager did not copy the resource file {0} as a {2} resource type for {3} because it could not unpack the archive.

**Explanation:**

Transform Manager did not copy the resource file {0} as a {2} resource type for {3} because it could not unpack the archive. The archive might be damaged or it was created with a non-supported archive tool.

**System action:**

The user specified that the uploaded file is an archive but it could not be unpacked by the shell script.

**User response:**

If the file is an archive, make sure it is created with the resource packaging tools included with Transform Manager or with a supported archiving tool, such as pkzip, zip, tgz, or gzip. Otherwise, change the archive setting of the file and resubmit the job.

---

**EJZ00228E Transform Manager did not copy the resource file {0} as a {2} resource type for {3} on the Transform Server {1} because some files were already present.**

**Explanation:**

Transform Manager did not copy the resource file {0} as a {2} resource type for {3} on the Transform Server {1} because some files were already present. Some files were already found in one of the target directories, and the user specified that the copy operation should fail if files already exist.

**System action:**

None.

**User response:**

If you still want to distribute the resources, please choose a different value for the **Existing Values** field.

---

**EJZ00229E Transform Manager did not copy the resource file {0} as a {2} resource type for {3} on the Transform Server {1} because an internal error occurred.**

**Explanation:**

A usage, configuration, or unexpected type of error occurred while copying the resource. Additional information may be stored in the log files.

**System action:**

None.

**User response:**

Try resubmitting the job, and if this error appears again, save the traces for that Transform Server using the **Export Traces** button. Contact InfoPrint Solutions Company customer service.

---

**EJZ00230I Transform Manager successfully copied the resource file {0} as a {2} resource type for {3} on the Transform Server {1}.**

**Explanation:**

The resource copy process was successful on the specified Transform Server.

**System action:**

Processing continues.

**User response:**

None.

---

**EJZ00231W The Transform Manager successfully copied the resources file {0} as a {2} resource type for {3} on the Transform Server {1}, but some files were skipped.**

**Explanation:**

Some files were already found in one of the target directories, and the user specified that the distribution should skip the files that already exist

**System action:**

Processing continues. Existing files were skipped.

**User response:**

None.

---

**EJZ00232W The Transform Manager successfully copied the resources file {0} as a {2} resource type for {3} on the Transform Server {1}, but some files were overwritten.**

**Explanation:**

Some files were already found in one of the target directories, and the user specified that the distribution should overwrite the files that already exist.

**System action:**

Processing continues. Existing files were overwritten.

**User response:**

None.

---

**EJZ00233E Transform Manager did not copy the resource file {0} as a {2} resource type for {3} on the Transform Server {1} because the Transform Server does not support the selected transform or resource type.**

**Explanation:**

This error can be caused by a transform shipped as a PRPQ (such as afp2pdf) that is installed on the local Transform Server, but it isn't on the Transform Server reporting the error.

**System action:**

None.

**User response:**

When the transform that you are copying resources for is shipped as a PRPQ, make sure that the transform is installed on the Transform Server that reported the error. You should also make sure that the Transform Server that reported the error is not an older version than the local Transform Server.

---

**EJZ00246E Transform Manager could not recognize the hostname {0} on this network while trying to unregistor with the print server {1}.**

**Explanation:**

| Transform Manager did not find the print server's host name when trying to unregister with it.

| **System action:**

| The print server was deleted from the Transform Manager's list.

| **User response:**

| None.

---

| **EJZ00247E Transform Manager encountered a communication error while trying to unregister with the print server {0}.**

| **Explanation:**

| Transform Manager encountered a communication problem when trying to unregister with the specified print server.

| **System action:**

| The print server was deleted from the Transform Manager's list.

| **User response:**

| None.

---

| **EJZ00248E Transform Manager failed to unregister with the print server at address {0} and port {1} because the print server initialization failed with the following message: {2}**

| **Explanation:**

| The specified print server returned an error when the Transform Manager tried to unregister from it.

| **System action:**

| None.

| **User response:**

| Fix the problem indicated in the error message and try to unregister the print server again.

---

| **EJZ00249W Transform Manager successfully removed the print server {0}, but the print server is still registered with the Transform Manager.**

| **Explanation:**

| Transform Manager detected that at some time the print server was associated with this Transform Manager and the unregistration process could not be completed (because of some type of error).

| **System action:**

| Future jobs may still be sent to this Transform Manager.

| **User response:**

| Add the printer server and then remove it. If an initialization error message displays when adding the print server, fix the indicated problem.

---

| **EJZ00250E Transform Manager received the command to reconnect to these print servers: *list of print servers*.**

| **Explanation:**

| The user issued the command to reconnect to list of print servers.

| **System action:**

| Transform Manager reconnects the list of print servers.

| **User response:**

| None.

---

| **EJZ00251E Transform Manager could not reconnect to the print server {0} because it is no longer associated with the Transform Manager.**

| **Explanation:**

| Transform Manager could not find the specified print server in the list of print servers because it has been removed, and the main page has not refreshed yet.

| **System action:**

| None.

| **User response:**

| None.

---

| **EJZ00252E Transform Manager could not reconnect to the print server at the host name {0}.**

| **Explanation:**

| This host name is not recognized on this network. This could be caused by a network communication error.

| **System action:**

| Transform Manager could not find the specified hostname on the network.

| **User response:**

| Make sure that the hostname is recognized on the network and resubmit the command. If the hostname is incorrect, remove the print server and add it again with the correct host name.

---

| **EJZ00253E Transform Manager encountered a communication error with the print server {0} when trying to reconnect to it.**

| **Explanation:**

| Transform Manager could not connect to the specified print server.

| **System action:**

| None.

| **User response:**

| Contact your network administrator to resolve connectivity issues.

---

**EJZ00254E Transform Manager could not reconnect to the print server at address {0} and port {1} because the print server initialization failed with the following message: {2}**

**Explanation:**

The specified print server returned an error when the Transform Manager tried to register with it.

**System action:**

None.

**User response:**

Fix the problem indicated in the error message and try to reconnect again.

---

**EJZ00255I Transform Manager successfully reconnected to the print server {0}.**

**Explanation:**

The specified print server returned an error when the Transform Manager tried to register with it.

**System action:**

Transform Manager completed the registration process for the specified print server

**User response:**

None.

---

**EJZ00256W Transform Manager did not attempt to reconnect to the print server {0} because this operation is not supported for this type of printer.**

**Explanation:**

The selected print server does not require registration with the Transform Manager.

**System action:**

None.

**User response:**

None.

---

**EJZ00257W Transform Manager failed to reconnect to the print server {0} that was registered with the Transform Manager.**

**Explanation:**

Transform Manager could not reconnect to the specified print server, but Transform Manager was registered with the print server some time in the past. Therefore, future jobs might still be sent to this Transform Manager.

**System action:**

None.

**User response:**

None.

---

**FUY04001 Failed opening connection. Host: <IP address or host name> Port: <port number>.**

**Explanation:**

An error occurred when the print server attempted to open the connection with Transform Manager. The connection was not opened.

**System action:**

Processing stops

**User response:**

Make sure that you specified the *IP address* or *host name* and *port number* of the Transform Manager correctly. Validate that the print server can have bi-directional communication with Transform Manager using ports 6984 and 6986. For more information, see the documentation for your InfoPrint Manager for AIX and Windows, InfoPrint ProcessDirector, or Infoprint Server for z/OS.

---

**FUY04002 Failed opening connection. Socket number: <socket number>.**

**Explanation:**

An error occurred when the print server attempted to open the connection with Transform Manager. The connection was not opened.

**System action:**

Processing stops.

**User response:**

Verify that the *socket number* number for Transform Manager is correct in the print server configuration.

---

**FUY04003 Error sending data.**

**Explanation:**

The Print server interface reported an error when attempting to send data to Transform Manager.

**System action:**

Processing stops.

**User response:**

Verify that a connection to Transform Manager is still available, and resubmit.

---

**FUY04004 Error generated by Transform Manager.**

**Explanation:**

The Print server interface received a message from Transform Manager that states that an error has occurred.

**System action:**

Processing stops.

**User response:**

Verify that Transform Manager is running correctly. Resubmit the request.

---

**FUY04005 Transform not supported: <transform ID>.**

**Explanation:**

The Print server interface requested a transform ID that is not supported by Transform Manager.

**System action:**

Processing stops.

**User response:**

Resubmit with a valid transform ID, as shown in “Transform Manager transform IDs” on page 129.

---

**FUY04006 Key not supported by Transform Manager: <name of key>.**

**Explanation:**

The Print server interface sent a *key* that is not supported by the Transform Manager.

**System action:**

Processing stops.

**User response:**

Contact Software Support.

---

**FUY04007 Input data type not recognized by sniffer.**

**Explanation:**

The Transform Manager encountered an error when running the sniffer. The data type was not recognized by the sniffer.

**System action:**

Processing stops.

**User response:**

Determine if the data type is valid, and if not, adjust the request as appropriate.

---

**FUY04008 Output file <file name> does not exist or cannot be accessed.**

**Explanation:**

The Transform Manager encountered an error when attempting to open or create the output file *file name*. This error can occur because Transform Manager was unable to create the output file, the output file does not exist, the permissions are incorrect, or the path is specified incorrectly.

**System action:**

Processing stops.

**User response:**

Verify that the output file is accessible, and resubmit the job.

---

**FUY04009 Input file <file name> does not exist or cannot be accessed.**

**Explanation:**

The Transform Manager encountered an error when attempting to open the input file *file name*. This error can occur because the file does not exist, the permissions are incorrect, or the path is specified incorrectly.

**System action:**

Processing stops.

**User response:**

Verify that the input file is accessible, and resubmit the job.

---

**FUY04010 Resource <resource name> does not exist or cannot be accessed.**

**Explanation:**

The Transform Manager encountered an error when attempting to open a resource *resource name*. This error can occur because the resource does not exist, the permissions are incorrect, or the path is specified incorrectly.

**System action:**

Processing stops.

**User response:**

Verify that the resource is accessible, and correct any errors before resubmitting the job.

---

**FUY04011 An invalid <key/value> pair was provided to the Print server interface.**

**Explanation:**

The Print server interface received an invalid *key/value* pair.

**System action:**

Processing stops.

**User response:**

Verify that the parameters are correct and resubmit. Contact Software Support for the Print server you are using, such as InfoPrint Manager for AIX or Infoprint Server for z/OS.

---

**FUY04012 The Print server interface encountered a syntax error.**

**Explanation:**

The Print server interface found a syntax problem. It can be a missing argument, handler, or key.

**System action:**

Processing stops.

**User response:**

Contact Software Support.

---

---

**FUY04013 The Print server interface encountered a logic error.****Explanation:**

The Print server interface found a program error.. Possibilities are: multiple transforms were requested for a single instance, multiple tasks for a single instance, or task state mismatch.

**System action:**

Processing stops.

**User response:**

Contact Software Support.

---

**FUY04014 The Print server interface encountered a trace error.****Explanation:**

The Print server interface found a tracing problem. That is, the Print server interface had a problem using the trace handler.

**System action:**

Processing stops.

**User response:**

Contact Software Support.

---

**FUY04015 The Print server interface encountered a message catalog error.****Explanation:**

The Print server interface could not open a message catalog or request a message from the message catalog.

**System action:**

Processing stops.

**User response:**

Contact Software Support.

---

**FUY04016 The Print server interface encountered a failure.****Explanation:**

The Print server interface failed.

**System action:**

Processing stops.

**User response:**

Contact Software Support.

---

**FUY04017 Flag <flag name> is followed by an invalid value.****Explanation:**

The Transform Manager found a flag that has an invalid value or missing value.

**System action:**

Processing stops.

**User response:**

Verify that the value specified with the *flag name* is valid, and resubmit the job.

---

**FUY04018 The Print server interface encountered an internal error.****Explanation:**

The Print server interface encountered an error while using the communication protocol.

**System action:**

Processing stops.

**User response:**

Contact IBM Software Support.

---

**FUY04019 Error receiving data.****Explanation:**

The Print server interface reported an error when attempting to receive data from the Transform Manager.

**System action:**

Processing stops.

**User response:**

Verify that a connection to Transform Manager is still available.

---

**FUY04020 Job failed in Transform Manager with job error: <job error>.****Explanation:**

The Transform Manager reported that the job has failed. In the message text, *job error* is a numeric code that can help Software Support diagnose the problem. When *job error* is 100, an optional transform, such as **afp2pdf**, is not installed.

**System action:**

Processing stops.

**User response:**

Determine what job error occurred and resubmit the job. To determine what error occurred, look at the associated transform messages, if any. The transform messages might be printed on a separate page at the end of the output or in the print server's message log. If you need assistance, contact Software Support and provide the numeric code in the message.

When *job error* is 100, determine which transform is not installed, install the optional transform, and resubmit the job.

---

**FUY04021 Transform Manager has processed <number of pages> pages.****Explanation:**

The Transform Manager has sent a status update of how many pages have been processed.

**System action:**

Processing continues. This is an informational message.

**User response:**

None.

---

**FUY04022 Missing a required argument or flag.**

**Explanation:**

The ITM Driver was called with a missing required flag.

**System action:**

Processing stops.

**User response:**

Verify that the command contains all required flags. When using a control/configuration file, verify that the combination of command line flags and arguments in the control/configuration file contains all required arguments or flags.

---

**FUY04023 Invalid flag: <flag>.**

**Explanation:**

The ITM Driver was executed with an invalid flag.

**System action:**

Processing stops.

**User response:**

Remove the invalid flag and resubmit the request.

---

**FUY04024 Error opening control/configuration file: <filename>.**

**Explanation:**

The ITM Driver was executed with the **-C** flag, but an invalid configuration file was provided.

**System action:**

Processing stops.

**User response:**

Verify and correct the configuration/control file, and resubmit the request.

---

**FUY04025 Error reading control/configuration file: <filename>.**

**Explanation:**

The ITM Driver was unable to read the control/configuration file. This error can be caused by file reading procedures or an incorrectly built control/configuration file.

**System action:**

Processing stops.

**User response:**

Verify that the control/configuration file is valid, and resubmit the request.

---

**FUY04026 Attribute <attribute name> doesn't have a value.**

**Explanation:**

The ITM Driver read an attribute from the control/configuration file, but the argument had no value.

**System action:**

Processing stops.

**User response:**

Modify the configuration/control file and provide the corresponding value for the attribute.

---

**FUY04027 Attribute <attribute name> is not supported.**

**Explanation:**

The ITM Driver read an invalid attribute from the control/configuration file.

**System action:**

Processing stops.

**User response:**

Remove the invalid attribute from the control/configuration file.

---

**FUY04028 Error parsing Transforms' options and values.**

**Explanation:**

The ITM Driver was unable to parse the Transforms' options and values, known as the Transform flags that are sent to the ITM server.

**System action:**

Processing stops.

**User response:**

Verify that the **-F** flag or the **trans\_flags** argument contains a correct list of Transform options and values.

---

**FUY04029 Error reading command line flags and values.**

**Explanation:**

The ITM Driver was unable to read the command line flags and values.

**System action:**

Processing stops.

**User response:**

Verify that the command line flags are correct, and resubmit the request.



---

## Transform Manager transform IDs

This section lists the Transform Manager transform IDs. In most cases, administrators and job submitters do not need to know the transform IDs. However, Infoprint Server for z/OS lets job submitters request a particular transform by specifying the ID of the transform during job submission. For more information, see the Infoprint Server for z/OS documentation.

Datastream	Transform ID
AFP (See <b>Note</b> about AFP data.)	8040
JPEG, GIF, and TIFF	8000
PostScript	8011
PDF	8012
PCL	8033

**Note:** When the Infoprint Transform Manager: afp2pdf Transform i-listed PRPQ, Program Number 5799-TWL, is purchased, Transform Manager supports the transform of AFP data to PDF data. For information about the **afp2pdf** transform, see *Infoprint Transform Manager: afp2pdf Transform Installation and User's Guide*, G550-0538.



---

# Glossary

This glossary defines technical terms and abbreviations used in InfoPrint Transform Manager documentation. If you do not find the term you are looking for, view *IBM Terminology* at:

<http://www.ibm.com/ibm/terminology>

Definitions reprinted from the *American National Dictionary for Information Processing Systems* are identified by the symbol (A) following the definition.

Definitions reprinted from a published section of the International Organization for Standardization (ISO) *Vocabulary—Information Processing* or from a published section of *Vocabulary—Office Machines* developed by Subcommittee 1, Joint Technical Committee 1, of the International Organization for Standardization and the International Electrotechnical Committee (ISO/IEC JTC1/SC1) are identified by the symbol (I) following the definition. Because many ISO definitions are also reproduced in the *American National Dictionary for Information Processing Systems*, ISO definitions can also be identified by the symbol (A).

These cross-references are used in this glossary:

- **See.** Refers to multiple-word terms in which this term appears.
- **See also.** Refers to related terms that have similar, but not synonymous, meanings.

## A

**access control.** In computer security, the methods and facilities used to ensure that a computer system and the data, system software, and application programs stored in it can be accessed only by authorized users in authorized ways.

**Advanced Function Presentation (AFP).** A set of licensed programs, together with user applications, that use the all-points-addressable concept to print data on a wide variety of printers or display data on a variety of display devices. AFP also includes creating, formatting, archiving, retrieving, viewing, and distributing information.

**AFP.** See *Advanced Function Presentation*.

**AIX.** Advanced Interactive Executive operating system, which is IBM's implementation of the UNIX® operating system.

## C

**client.** In a distributed file system environment, a system that is dependent on a server to provide it with programs or access to programs.

**client/server.** In communications, the model of interaction in distributed data processing in which a program at one site sends a request to a program at another site and awaits a response. The requesting program is called a client; the answering program is called a server.

**command.** A request from a terminal or a specification in a batch-processing print file for the performance of an operation or the running of a particular program.

## F

**file.** (1) A collection of related data that is stored and retrieved by an assigned name. (2) Linear data that can be opened, written, read, and closed. A file can also contain information about the file, such as authorization information. The name used to obtain a file includes the directories in the path to the file.

## G

**GIF.** Graphics interchange format for images.

## H

**host name.** (1) The network name for a print server or transform server. The host name is the fully-qualified domain name or a specific subname of a fully-qualified domain name. For example, if `printserver1.boulder.ibm.com` is the fully-qualified domain name, either `printserver1.boulder.ibm.com` or `printserver1` can be the host name. (2) See also *IP address*.

## I

**InfoPrint.** A solution of software and hardware products that can supplement or replace the offset presses and copiers in print shops with high-quality, non-impact, black and white or process color printers. InfoPrint takes documents from creation to the final product.

**InfoPrint Manager for AIX or Windows.** A software component of InfoPrint Solutions Company. InfoPrint Manager for AIX or Windows is a print server that handles the scheduling, archiving, retrieving, and

assembly of a print job and its related resource files. It also tracks the finishing and packaging of the printed product.

**IP address.** (1) In the Internet suite of protocols, the 32-bit address of a print server or transform server, expressed in dotted decimal notation. For example: 9.99.9.143. (2) See also *host name*.

## J

**JPEG.** Joint Photographic Experts Group image format.

## L

**Linux.** An open source implementation of the UNIX system.

## M

**mount.** To make a file system accessible.

## N

**network.** A collection of data processing products that are connected by communication lines for information exchange between locations.

## P

**PDF.** See *Portable Document Format*.

**persistent.** Pertaining to data that is maintained across session boundaries, usually in nonvolatile storage such as a database system or a directory.

**port.** (1) A part of the system unit or remote controller to which cables for external devices (display stations, terminals, or printers) are attached. The port is an access point for data entry or exit. (2) A specific communications endpoint within a host. A port is identified by a port number.

**Portable Document Format (PDF).** A universal file format that preserves the fonts, images, graphics, and layout of any source document so it can be viewed and printed on a variety of platforms.

**PostScript (PS).** A page description language with graphics capabilities that was developed by Adobe Systems, Incorporated.

**print server.** A computer to which one or more printers are connected or the process that manages those printers.

**processor.** In a computer, a functional unit that interprets and executes instructions. (I) (A)

**PS.** See *PostScript*.

## R

**root.** The user name for the system user with the most authority.

## S

**server.** (1) On a network, the computer that contains the data or provides the facilities to be accessed by other computers on the network. (2) A program that handles protocol, queuing, routing, and other tasks necessary for data transfer between devices in a computer system.

**spool.** The system function of putting files or jobs into disk storage for later processing or printing.

## T

**trace.** A record of the execution of a computer program. It exhibits the sequences in which the instructions were executed. (A)

**transform server.** The process that manages data and image transforms.

**TIFF.** Tagged image file format.

## U

**user interface.** Any of the actions or items that let a user interact with and perform operations on a computer, including graphical displays, components such as buttons or dials, or operating system commands.

## W

**Web browser.** A client program that initiates requests to a Web server and displays the information that the server returns.

**Web server.** The program that is capable of servicing Hypertext Transfer Protocol (HTTP) requests for display in a Web browser.

**Windows.** Pertaining to Windows 95, Windows 98, Windows NT<sup>®</sup>, Windows 2000, and later Microsoft operating systems.

**write access.** The authority to record data in a storage device or on a data medium.

# X

**X Window System.** A network-based graphics windowing system that provides the foundation on which a graphical user interface (GUI) can be built.



---

# Index

## Numerics

- 00000000.tab file 103
- 240-pel
  - output for PDF 89
  - output for PostScript 89
- 300-pel
  - output for PDF 89
  - output for PostScript 89
- 40010000.tab file 103
- 40040000.tab file 103
- 480-pel
  - output for PDF 89
  - output for PostScript 89
- 600-pel
  - output for PDF 89
  - output for PostScript 89

## A

- about information for Transform Manager 5
- accessibility 8
- Adobe PDF and PS transforms 2
- AFP, transforms to 2
- AIX
  - packaging scripts 34
- archive of multiple resources 33
- ASCII characters
  - conversion table for sap2afp transform 96
- automatic invocation
  - sap2afp transform 92

## B

- barcode.tab configuration file
  - ModWidth optional keyword 94
  - Ratio optional keyword 94
- barcode.tab file 94
- blade server requirements 9

## C

- changing passwords 21
- code page
  - mapping ASCII to EBCDIC for sap2afp 103
- component and print server interaction 2
- components, Transform Manager 2
- configuration files
  - barcode.tab 94
  - defcp.tab 96
  - fonts.tab 97
  - for sap2afp transform 93
  - image.tab 100
  - pagedef.tab 101
  - printer.tab 102
  - xxxxyyyy.tab 103
- configuring print servers 22
- copy resources 34

- copying resources 33
- customer fonts 99

## D

- data manager component 2
- data transforms to AFP 2
- defcp.tab file 96
- description 107
  - of transforms
    - GIF to AFP 47
    - JPEG to AFP 60
    - PCL to AFP 72
    - PDF to AFP 83
    - PostScript to AFP 83
    - sap2afp 92
    - TIFF to AFP 107
- directories, file 30
- disability 8

## E

- examples
  - of transforms
    - sap2afp 104

## F

- features, Transform Manager 1
- file directories 30
- files
  - barcode.tab 94
  - defcp.tab 96
  - fonts.tab 97
  - for transforms
    - sap2afp 93
  - image.tab 100
  - pagedef.tab 101
  - printer.tab 102
  - xxxxyyyy.tab 103
- flags
  - of transforms
    - PCL to AFP 73
    - PDF to AFP 84
    - PostScript to AFP 84
    - sap2afp 92
- fonts.tab file 97

## G

- GIF data to AFP data 45
- GIF to AFP
  - description 47
  - limitations 49
  - options 49
  - syntax 45
- GIF transform 2

## H

- hardware requirements 9
- height
  - PostScript image 87
- help, online user interface 5
- highlights, Transform Manager 1
- how the Transform Manager works 2
- HRI character 94
- human readable interface (HRI) character 94

## I

- IBM eServer BladeCenter
  - installing Transform Manager 17, 18
- image transforms to AFP 2
- image.tab file 100
- images
  - resolution 89
- InfoPrint Transform Manager for Linux
  - configuring print servers 22
- InfoPprint Transform Manager for Linux
  - file directories 30
  - installing 15
- InfoPrint Manager
  - authorizing Transform Manager user ID 22
  - defining to Transform Manager 23
  - messages 43
  - troubleshooting 43
- InfoPrint ProcessDirector
  - usage notes 43
- Infoprint Server for z/OS
  - usage notes 43
- Infoprint Transform Manager for Linux
  - installing 16, 38
  - system requirements 9
- InfoPrint Transform Manager for Linux
  - components 2
  - highlights 1
  - how it works 2
  - interaction between components and print servers 2
  - logging in to 18, 27
  - overview 1
  - print servers supported 2
  - system requirements 9
  - transforms 2
  - usage notes 2
- information about Transform Manager 5
- installing Transform Manager 15, 16, 38
- installing Transform Manager on an IBM eServer BladeCenter 17, 18

## J

- JPEG to AFP
  - description 60
  - limitations 62
  - options 62
  - syntax 58
- JPEG to AFP transform 58
- JPEG transform 2

## K

- keyboard 8
- keywords
  - PDF to AFP transform
    - height of image 87
    - length of image 87
    - maximum memory 88
    - resolution 89
    - selected pages 88
    - server time out 89
    - width of image 90
    - X offset 91
    - Y offset 91
  - PostScript to AFP transform
    - height of image 87
    - length of image 87
    - maximum memory 88
    - resolution 89
    - selected pages 88
    - server time out 89
    - width of image 90
    - X offset 91
    - Y offset 91

## L

- length
  - PostScript image 87
- length keyword
  - PDF to AFP transform 87
  - PostScript to AFP transform 87
- limitations 108
  - of transforms
    - GIF to AFP 49
    - JPEG to AFP 62
    - PCL to AFP 73
    - PDF to AFP 83
    - PostScript to AFP 83
    - TIFF to AFP 108
- Linux
  - packaging scripts 34
- logging in to Transform Manager 18, 27

## M

- margins of PDF images
  - X offset 91
  - Y offset 91
- margins of PostScript images
  - X offset 91
  - Y offset 91
- maximum memory keyword
  - PDF to AFP transform 88
  - PostScript to AFP transform 88
- messages
  - InfoPrint Manager 43
- ModWidth optional keyword
  - barcode.tab configuration file 94



## N

notices 10

## O

online help, user interface 5

options

of transforms

GIF to AFP 49

JPEG to AFP 62

TIFF to AFP 108

overview, Transform Manager 1

## P

packaging scripts

AIX operating system 34

Linux operating system 34

Windows operating system 34

z/OS operating system 34

pagedef.tab file 101

passwords

changing 21

PCL to AFP 71

description 72

flags 73

limitations 73

syntax 71

PCL to AFP transform 71

PDF

margins

X offset 91

Y offset 91

resolution of output 89

width of image 90

PDF AFP 82

PDF to AFP

syntax 83

PDF to AFP transform

keywords

height of image 87

length of image 87

maximum memory 88

resolution 89

selected pages 88

server time out 89

width of image 90

Y offset 91

PDF transform 2

pdf2fp transform

keywords

X offset 91

pel output

for PostScript 89

output for PDF 89

PostScript

height of image 87

length of image 87

margins

X offset 91

PostScript (*continued*)

margins (*continued*)

Y offset 91

resolution of output 89

width of image 90

PostScript to AFP 82

PostScript to AFP transform

keywords

height of image 87

length of image 87

maximum memory 88

resolution 89

selected pages 88

server time out 89

width of image 90

X offset 91

Y offset 91

syntax 83

print server and component interaction 2

print servers

configuring 22

support for Transform Manager 2

printer.tab file 102

PS transform 2

## R

R/3 output device

mapping to a logical destination 102

Ratio optional keyword

barcode.tab configuration file 94

receiving transform requests 2

requirements, blade server 9

requirements, system 9

reset

button 29

Transform Manager 29

resolution keyword

PDF to AFP transform 89

PostScript to AFP transform 89

Resource distributor 34

resources distributor 33

## S

SAP ABAP data to AFP data 91

SAP OTF data to AFP data 91

sap2afp command 91

sap2afp transform

automatic invocation 92

configuration files

barcode.tab 94

defcp.tab 96

fonts.tab 97

image.tab 100

pagedef.tab 101

printer.tab 102

xxxxyyyy.tab 103

converting ASCII to EBCDIC 96

description 92

examples 104

- sap2afp transform (*continued*)
  - flags 92
  - mapping bar codes to BCOCA 94
  - syntax 91
- selected pages keyword
  - PDF to AFP transform 88
  - PostScript to AFP transform 88
- server
  - time out keyword 89
- shortcut keys 8
- software requirements 9
- syntax 105
  - of transforms
    - GIF to AFP data 45
    - JPEG to AFP 58
    - PDF to AFP 83
    - PostScript to AFP 83
    - sap2afp 91
    - TIFF to AFP 105
  - PCL to AFP
    - of transforms 71
- system requirements 9

## T

- TIFF data to AFP data 104
- TIFF to AFP 105, 107, 108
  - options 108
- TIFF transform 2
- time outs
  - server 89
- transform GIF data to AFP 45
- transform IDs 129
- transform JPEG data to AFP 58
- Transform Manager
  - components 2
  - configuring print servers 22
  - file directories 30
  - highlights 1
  - how it works 2
  - installing 15, 16, 38
  - installing on an IBM eServer BladeCenter 17, 18
  - interaction between components and print servers 2
  - logging in to 18, 27
  - overview 1
  - print servers supported 2
  - system requirements 9
  - transforms 2
  - usage notes 2
- transform PCL data to AFP 71
- transform PDF data to AFP 82
- transform PostScript data to AFP 82
- transform requests
  - receiving 2
- transform SAP ABAP data to AFP 91
- transform SAP OTF data to AFP 91
- transform server component 2
- transform TIFF data to AFP 104
- transforms
  - GIF data to AFP 45
  - sap2afp 91

- transforms to AFP 2
- troubleshooting
  - InfoPrint Manager 43

## U

- usage notes
  - InfoPrint ProcessDirector 43
  - Infoprint Server for z/OS 43
  - Transform Manager 2
- user interface
  - component 2
  - logging in to 18, 27
  - online help 5

## V

- version information, Transform Manager 5

## W

- width
  - PDF image 90
  - PostScript image 90
- width keyword
  - PDF to AFP transform 90
  - PostScript to AFP transform 90
- Windows
  - packaging scripts 34

## X

- X offset keyword on PostScript to AFP or PDF to AFP
  - transform 91
- xxxxyyyy.tab file 103

## Y

- Y offset keyword on PostScript to AFP or PDF to AFP
  - transform 91

## Z

- z/OS
  - packaging scripts 34





Program Number: 5639-P51

Printed in USA

G550-1048-00

