

JES2 Exits Overview

Job Related Exits

Exit Environments



SHARE 104, Session 2665

Tuesday, March 1, 2005

Chip Wood
JES2 Design/Development/Service
Poughkeepsie, NY
chipwood@us.ibm.com

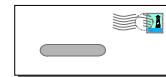

Permission is granted to SHARE Inc. to publish this presentation in the SHARE proceedings. IBM retains its right to distribute copies of this presentation to whomever it chooses.

Agenda



- Planning and researching your exit thoroughly
- Exit points
- Coding your exit
- Loading and enabling your exit
- Debugging your exit

Disclaimers



- From [JES2 Installation Exits](#), page 1:

Caution!

Defining exits and writing installation exit routines is intended to be accomplished by experienced system programmers; the reader is assumed to have knowledge of JES2.

If you want to customize JES2, IBM recommends that you use JES2 installation exits to accomplish the task. **IBM does not recommend or support alteration of JES2 source code.**

- From [JES2 Diagnosis](#):

CAUTION: IBM does not recommend or support modifications to JES2 source code. If you assume the risk of modifying JES2, then also assure that your modifications do not impact JES2 serviceability using IPCS. Otherwise, LEVEL2 may not be able to read JES2 dumps for problems unrelated to the modifications.

Make sure you need it



- Consider the following:
 - Do you have time, ability, and experience:
 - ▶ To write the exit?
 - ▶ To \$upport the exit?
 - Is the cost involved worth it?
 - Are there alternatives?
 - ▶ Can you use standard features/automation?
 - ▶ Can you use a manual procedure?
 - ▶ Has someone else solved the same problem (vendor product, mods tape, ...)?
 - ▶ Can you use table pairs instead?
 - ▶ Can you write an application using a supported interface (e.g. Extended status, SAPI)?

Exits vs. inline mods



- Exits are typically easier to maintain
 - Defined interface
 - Separate module, no interference from service updates
 - **++HOLD** if service changes something we anticipate an exit using
- Exits have limitations
 - Fixed points in processing
 - If there's no exit where you need it
 - ▶ Consider placing \$EXIT inline rather than extensive mods inline
 - ▶ Start with \$EXIT 255 and work your way down

Research your exit



- Choose the correct exit(s) for your task
- For example:
 - Set job attributes at input time:
 - ▶ Use exit 2 to set default attributes which can be overridden later
 - ▶ Use exit 20 to force attributes
 - Set job attributes at converter time
 - ▶ Use exit 6 to scan C/I text
 - ▶ Use exit 44 to store data in the JQE
- Many tasks require a combination of exits
 - Sample exit HASXJECL has a good example.

Research your exit



- Sources of information
 - [JES2 Exits](#)
 - Other JES2 Manuals
 - WSC Technical Bulletins and Flashes
 - SHARE Presentations
 - ▶ [How to Write an Error-free Exit](#) - Bob Jinkins, Summer 1994
 - ▶ [JES2 Job Related Exits](#) - John Hutchinson, Summer 2000
 - ▶ [Introduction to JES2 Table Pairs](#) - Chip Wood, Session 2665, Summer 2001
 - JES2 sample exits from **SYS1.SHASSAMP**
 - Exits from a "mods tape"
 - JES2 source code

Research your exit



- JES2 Exits are system extensions
 - **Supervisor state, Key 0 or Key 1!**
 - Can do as much damage as an inline mod!
- Before attempting to write an exit, understand:
 - JES2 exit environments
 - JES2 and MVS serialization
 - What control blocks are available (and when)
 - What point in processing exit gets control
 - What fields are set when you get control
 - What fields you can change
 - Which exits can \$WAIT
 - Which macros can \$WAIT
 - Which macros can be used in which exits
 - etc.

Plan for Migration



- Consult [z/OS Migration](#)
 - Exits may need extensive rework
 - Exits may no longer be needed
- Use field names rather than hard-coded offsets
 - Offsets may change
 - If field usage changes, IBM will **usually** change the name (and your exit will not assemble)
- Consider: Can JES2 with and without your changes coexist in the same MAS?
 - With exits enabled?
 - With exits disabled (control block changes only)?
 - If they can't coexist, is a cold start required?
 - Does your data survive a spool offload/reload?

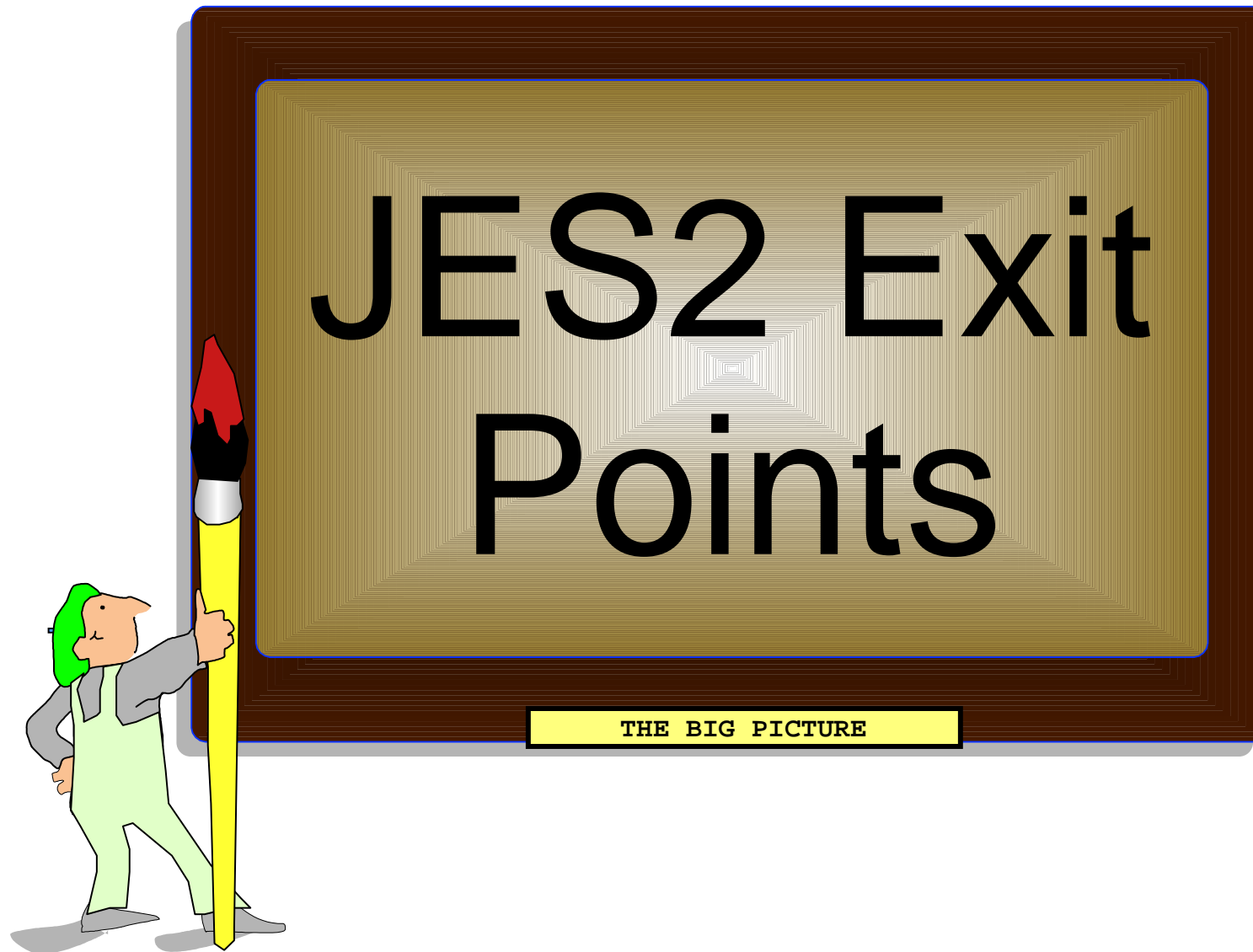

Exits and environments



Exit	Environment	Description
0	JES2	Initialization
1	JES2	Separator Page
2	JES2	Job Card
3	JES2	Accounting
4	JES2	JECL Card
5	JES2	Command
6	SUBTASK	Converter
7	JES2	\$CBIO
8	USER	\$CBIO
9	USER	Excession
10	JES2	\$WTO
11	JES2	\$TRACK
12	USER	\$STRAK
13	JES2	Netmail
14	JES2	\$QGET
15	JES2	DS Separator
16	JES2	Notify
17	JES2	BSC Signon
18	JES2	SNA Logon
19	JES2	Init statement
20	JES2	End of input
21	JES2	SMF
22	JES2	Cancel/Status
23	FSS	JSPA Separator
24	JES2	Post-initialization

Exit	Environment	Description
25	FSS	JCT I/O
26	JES2	Termination
27	JES2	PCE attach
28	USER	Job Termination
29	USER	End of Memory
30	USER	OPEN
31	USER	Allocation
32	USER	Job Select
33	USER	CLOSE
34	USER	Unallocation
35	USER	End of Task
36	USER	Pre-SAF
37	USER	Post-SAF
38	JES2	TSO Receive SAF
39	JES2	NSR SAF
40	JES2	Modify SYSOUT
41	USER	Generic Grouping
42	USER	Notify SSI
43	USER	APPC
44	JES2	Converter
45	USER	Pre-SJF
46	JES2	NJE Hdr XMIT
47	JES2	NJE Hdr Recv
48	USER	Late Unallocation
49	JES2	QGOT

The big picture



- Card reader
- TSO submit
- Internal reader
- STC, TSO intrdr
- RJE reader
- NJE Job Receiver
- Spool Offload

- NJE SYSOUT Receiver
- Spool Offload

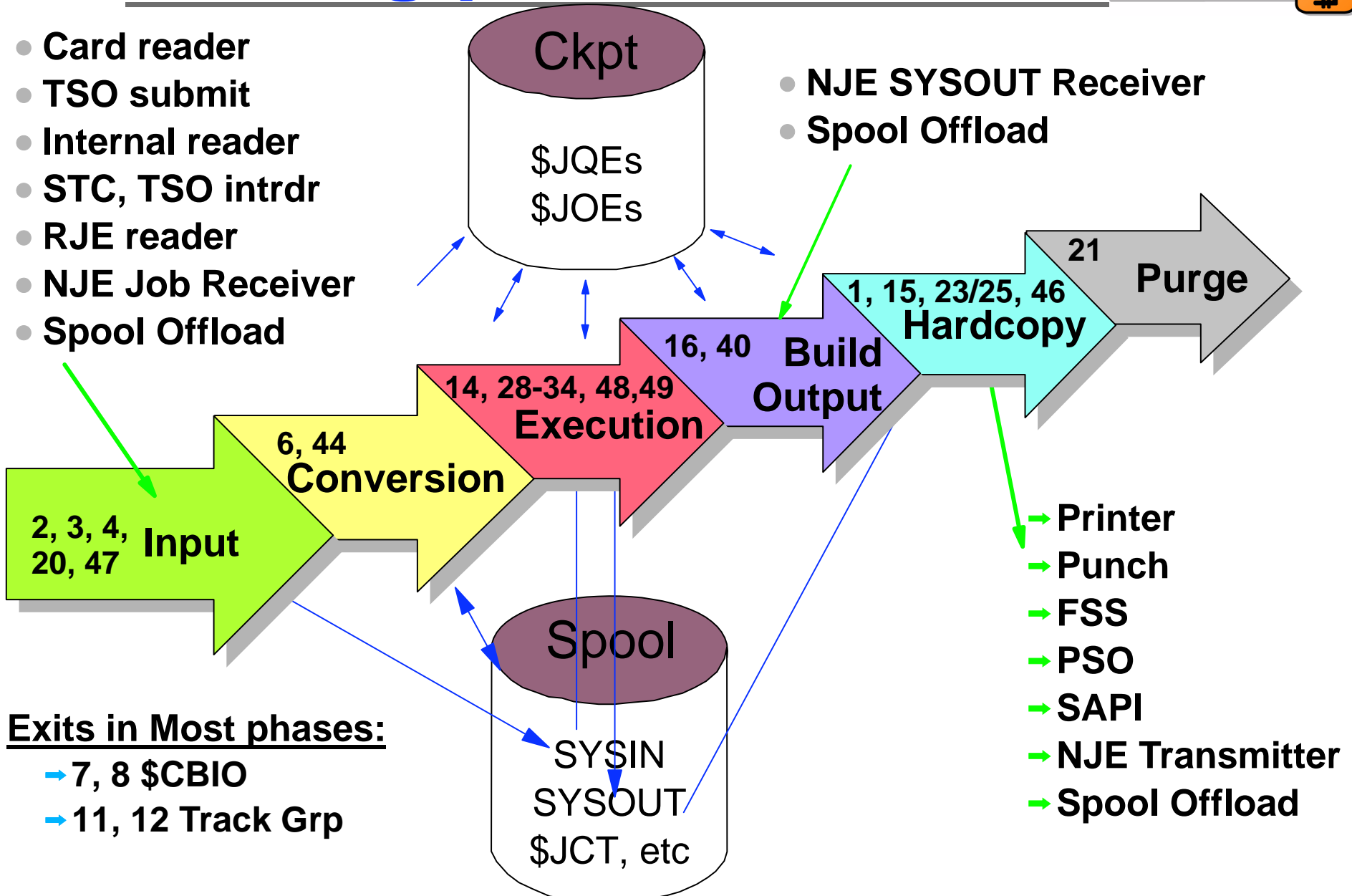

Exits in Most phases:

- 7, 8 \$CBIO
- 11, 12 Track Grp

Job Input Processing

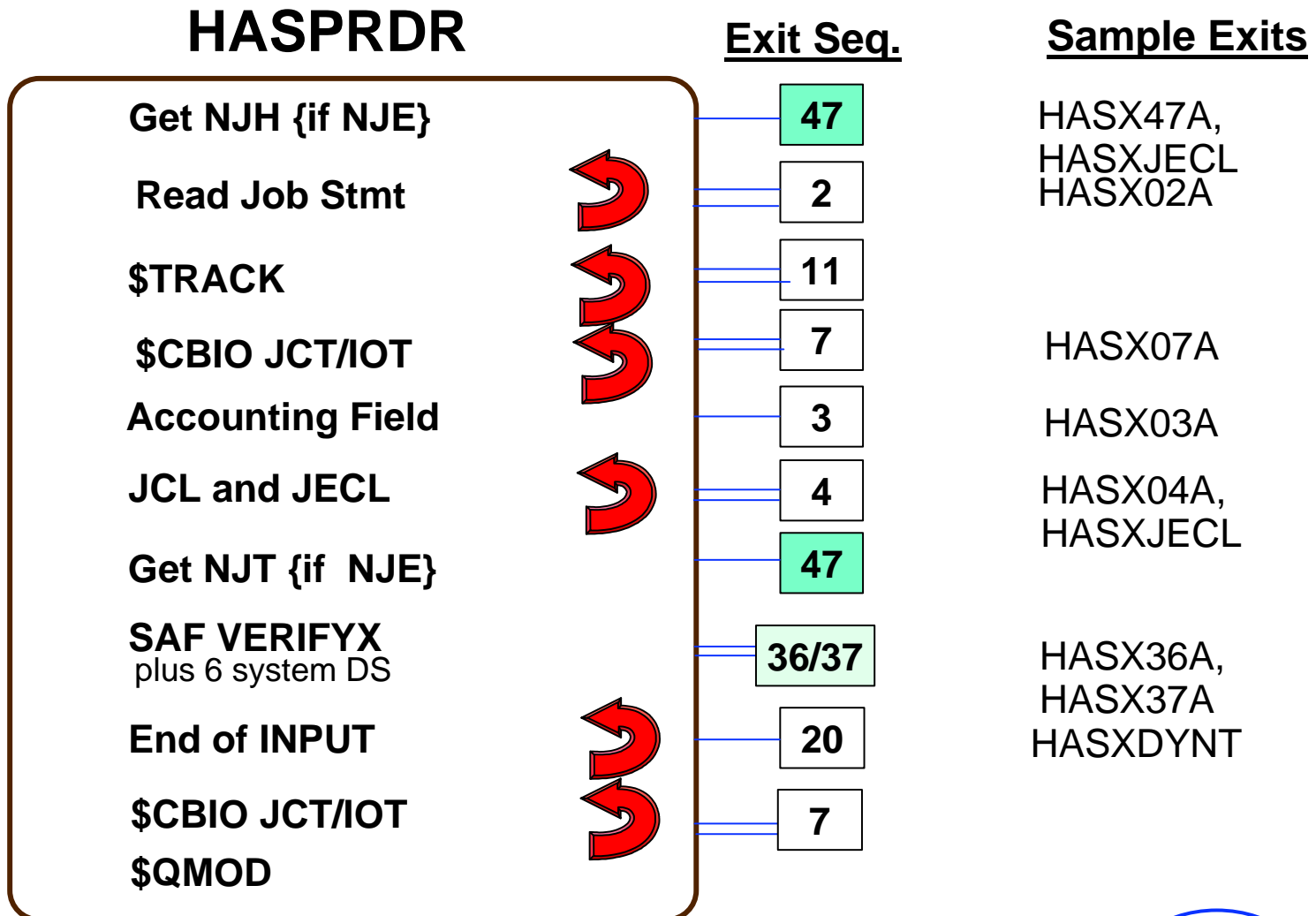

 = Exit may be called multiple times

Job Input Processing - the future....

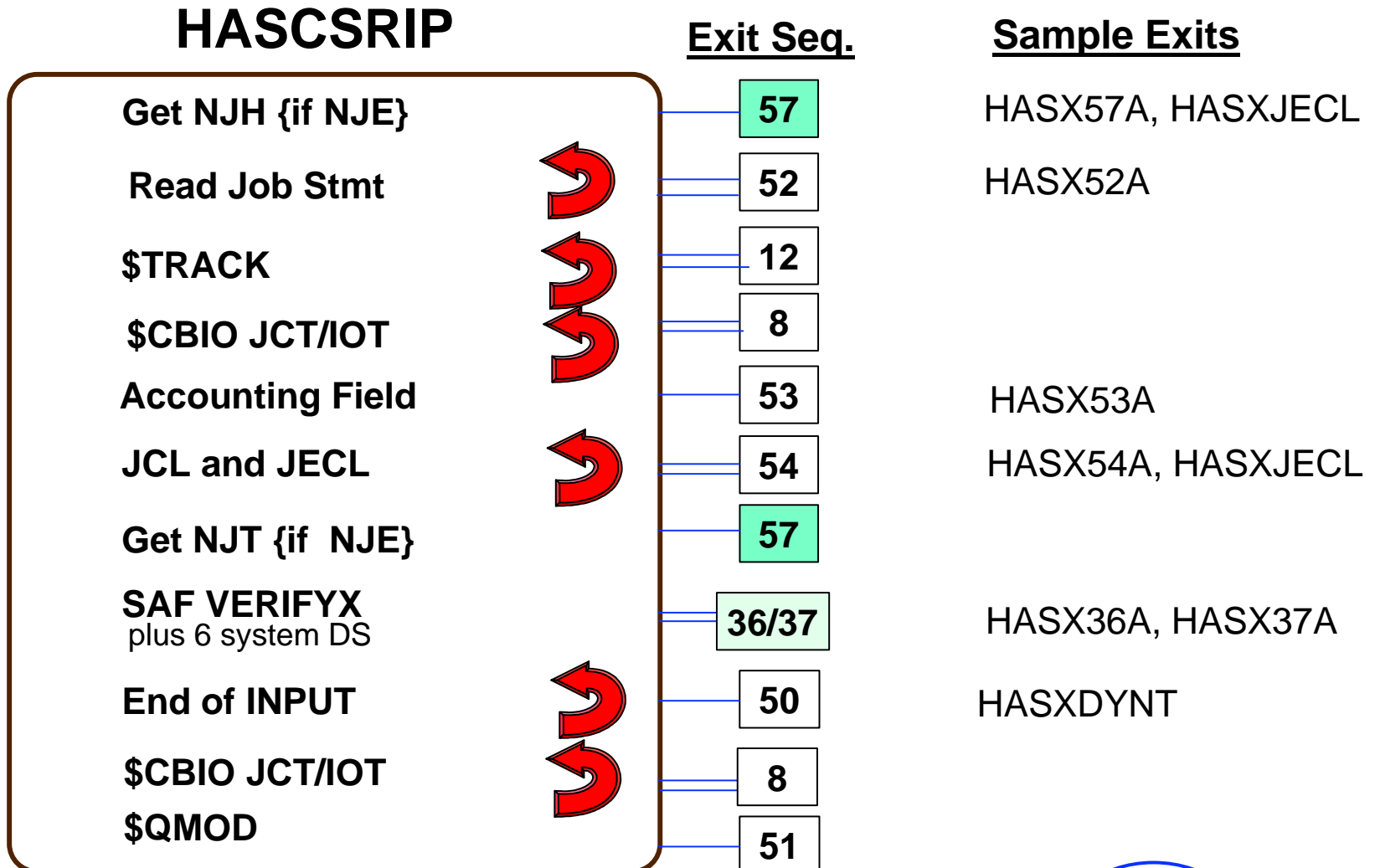

 = Exit may be called multiple times



Conversion Processing

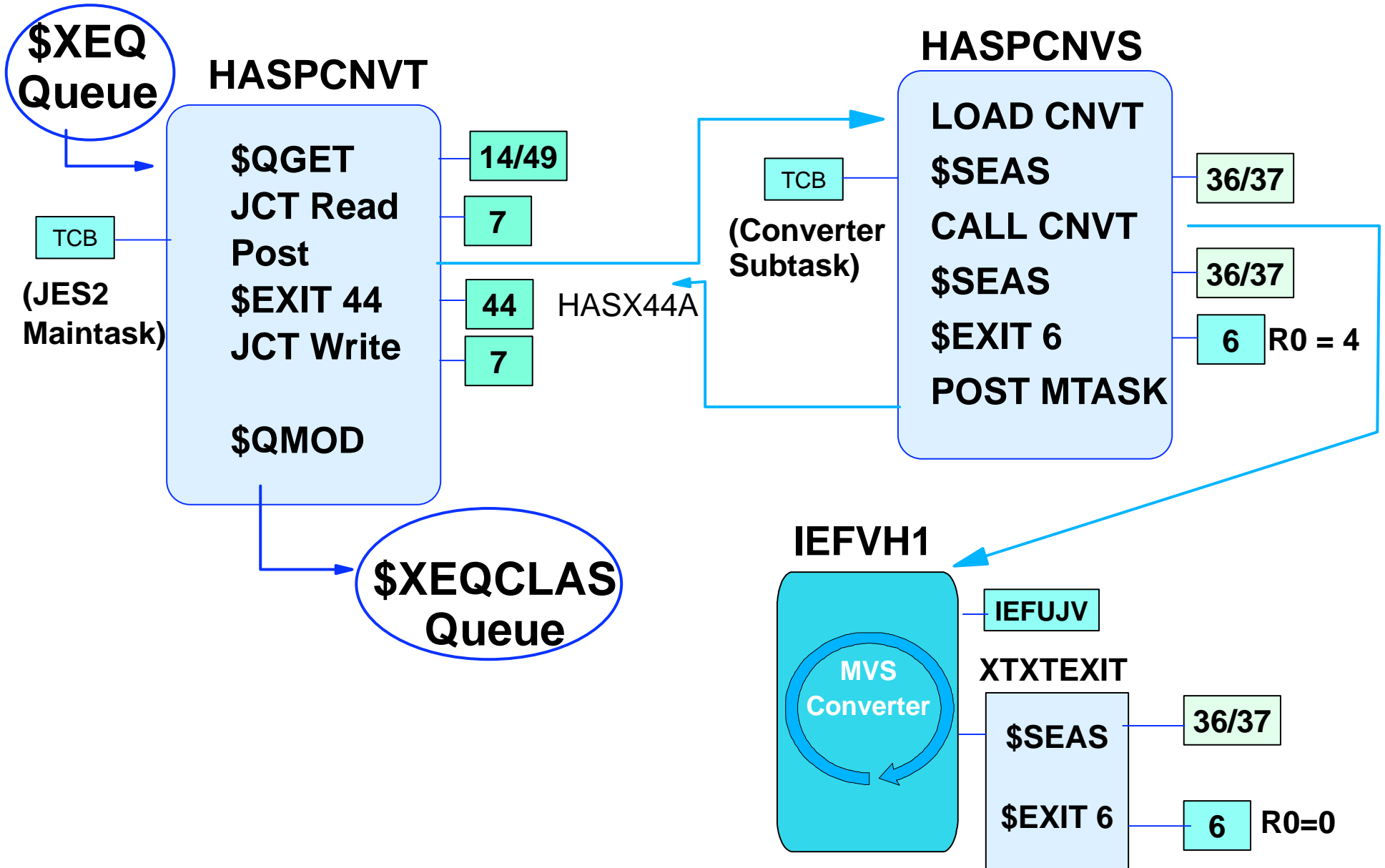

Execution, Part 1



IEFSD161 - HASCJBST

\$XEQCLAS
Queue

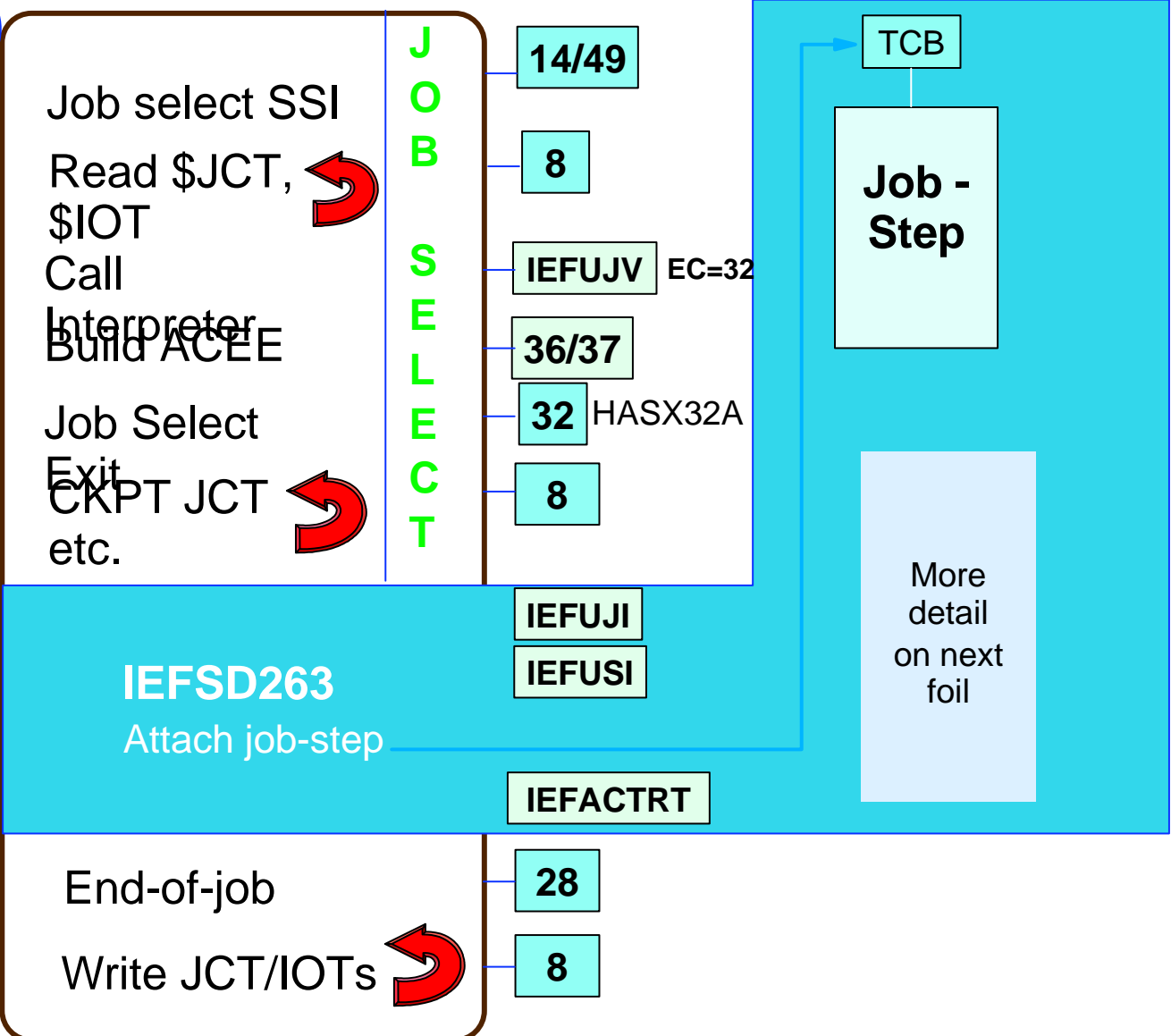

Execution, Part 2

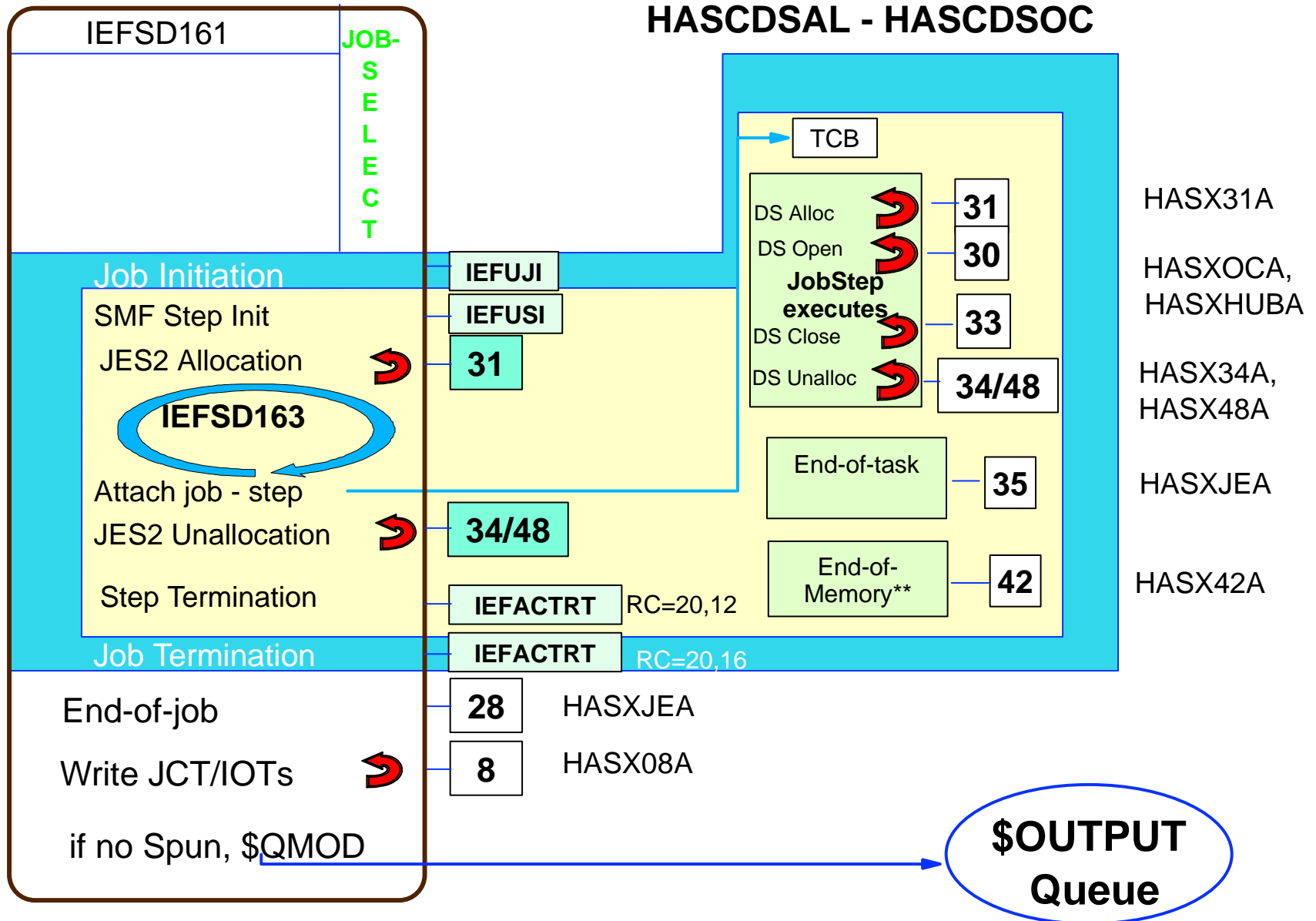

Output Spin Phase

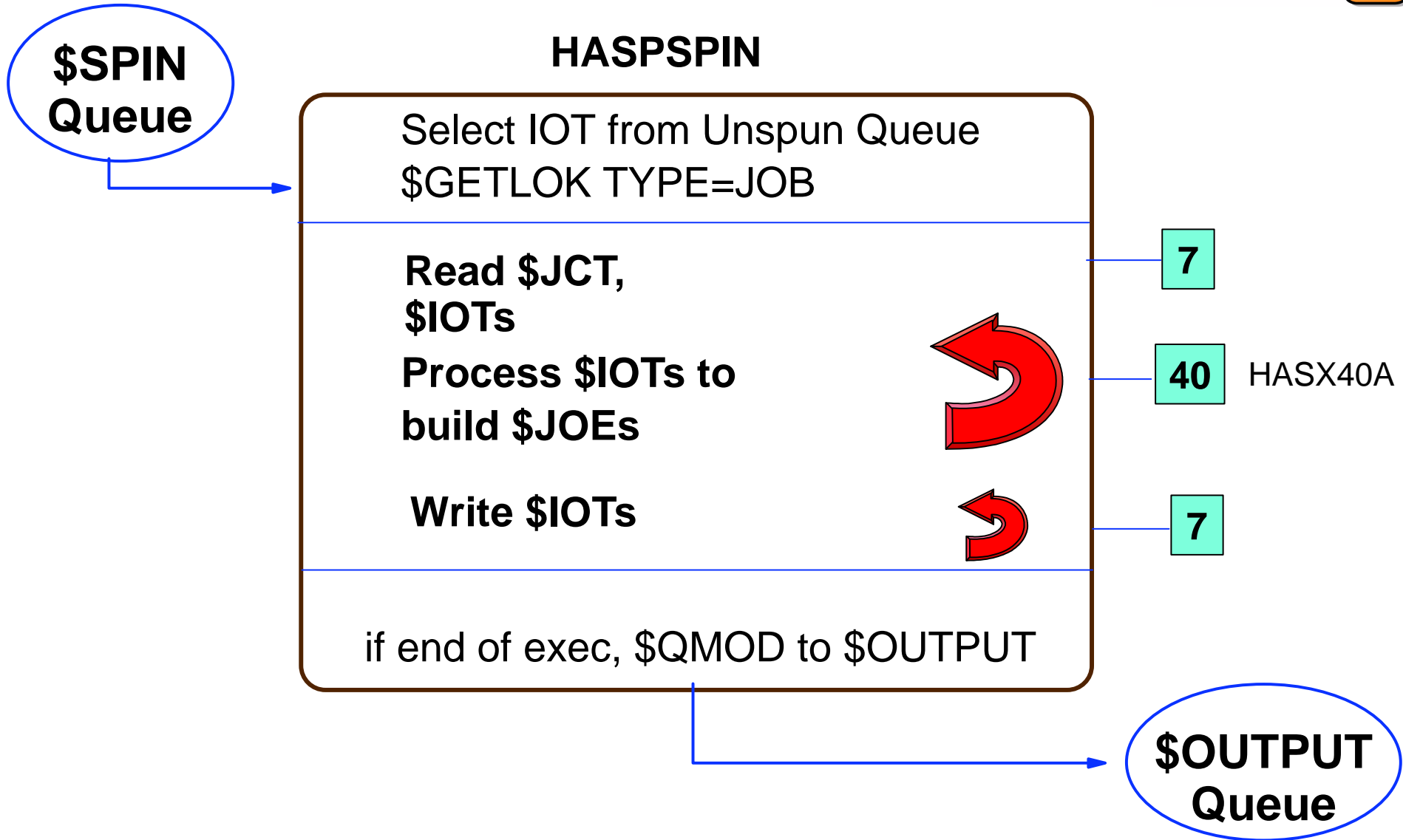

Output Phase



\$OUTPUT Queue

HASPHOPE - "HASP Output Processor Executor"

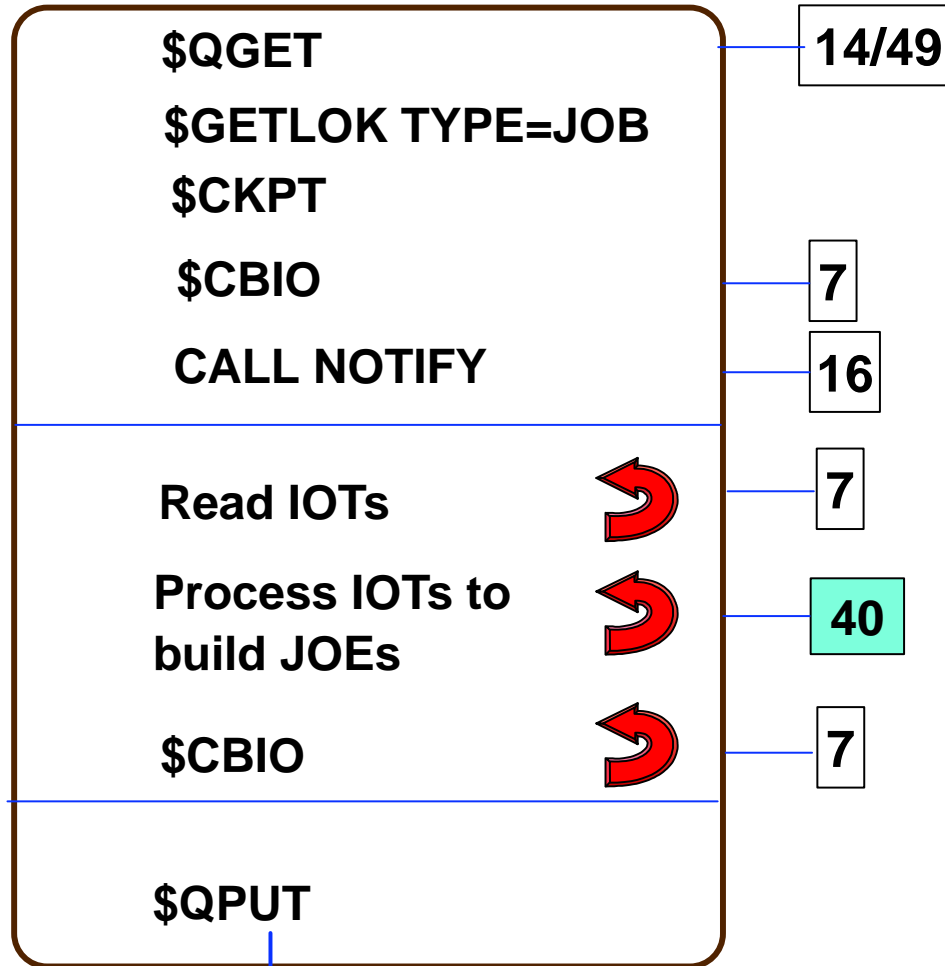

\$HARDCPY Queue

Hardcopy - JES2 Local & RJE Devices



HASPPRPU

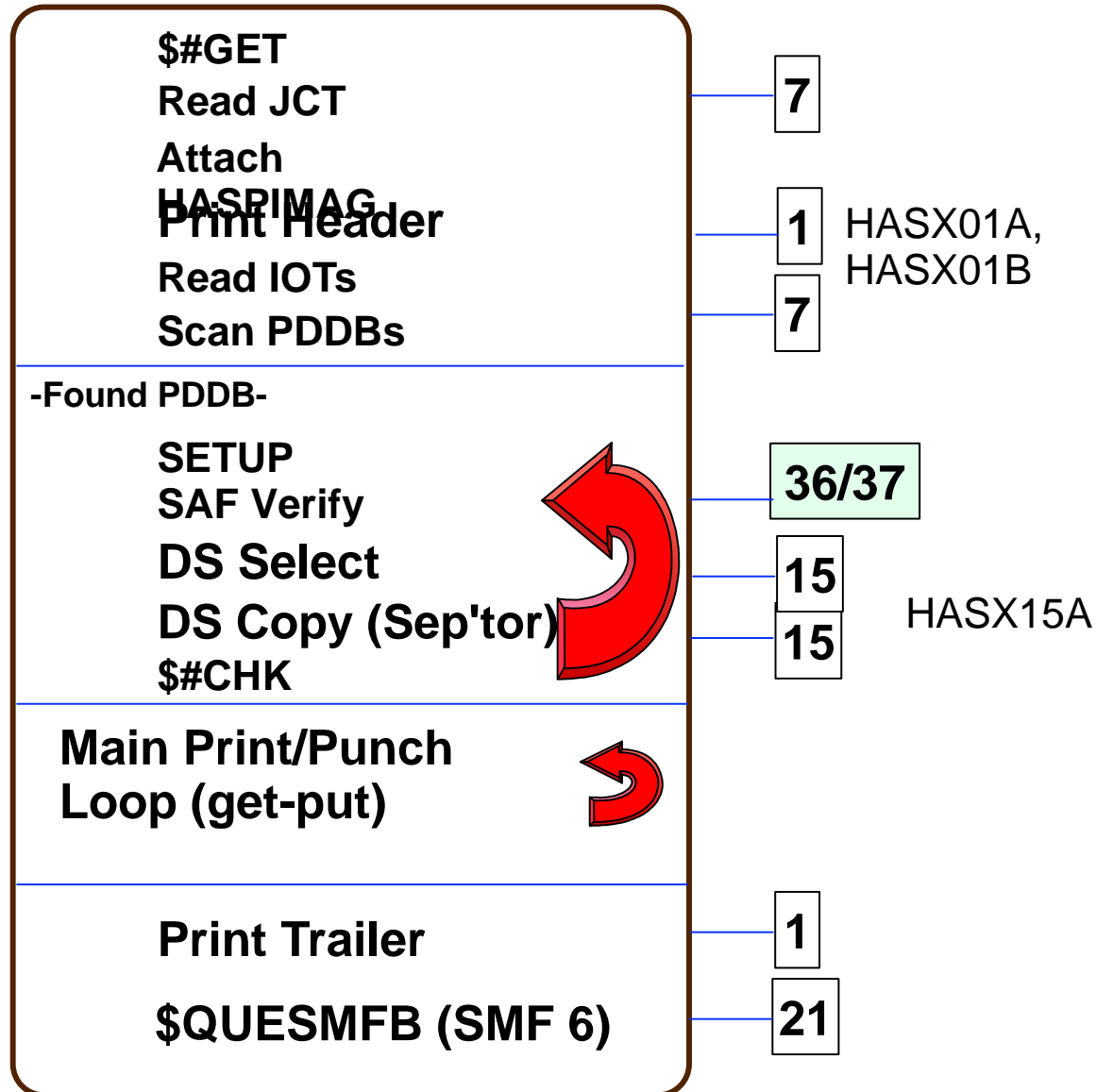

Hardcopy - FSS Devices (PSF printers)



PSF Addr.
Space

TCB

HASPFSSM

```

FSMGETDS
  Scan JIB queue
    (look for eligible JIB)
$CBIO (Read JCT)
  Initialize JSPA
$CBIO (read IOT)

$CALL PRRTAUTH
(JNEWS)
More JSPA initl.
$CALL FINDP (PDDB)
$CALL PRRTAUTH
$CALL DSOPEN (OPEN)
$CALL SWBRD (Read SWB)
GET (Initiate DS Input)
$CALL FINDP
(NEXT PDDB)
$RETURN (to FSS)
    
```

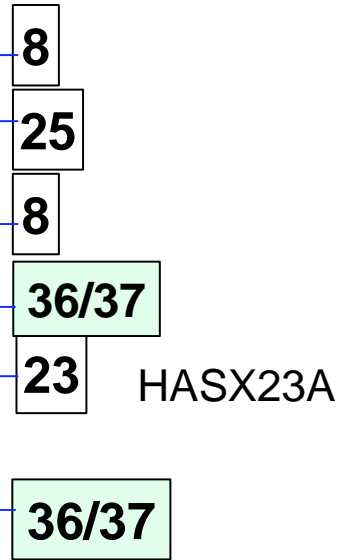

PSF Exits:
APSUX01-APSUX07

NJE & Spool Offload Transmitters



HASPNST

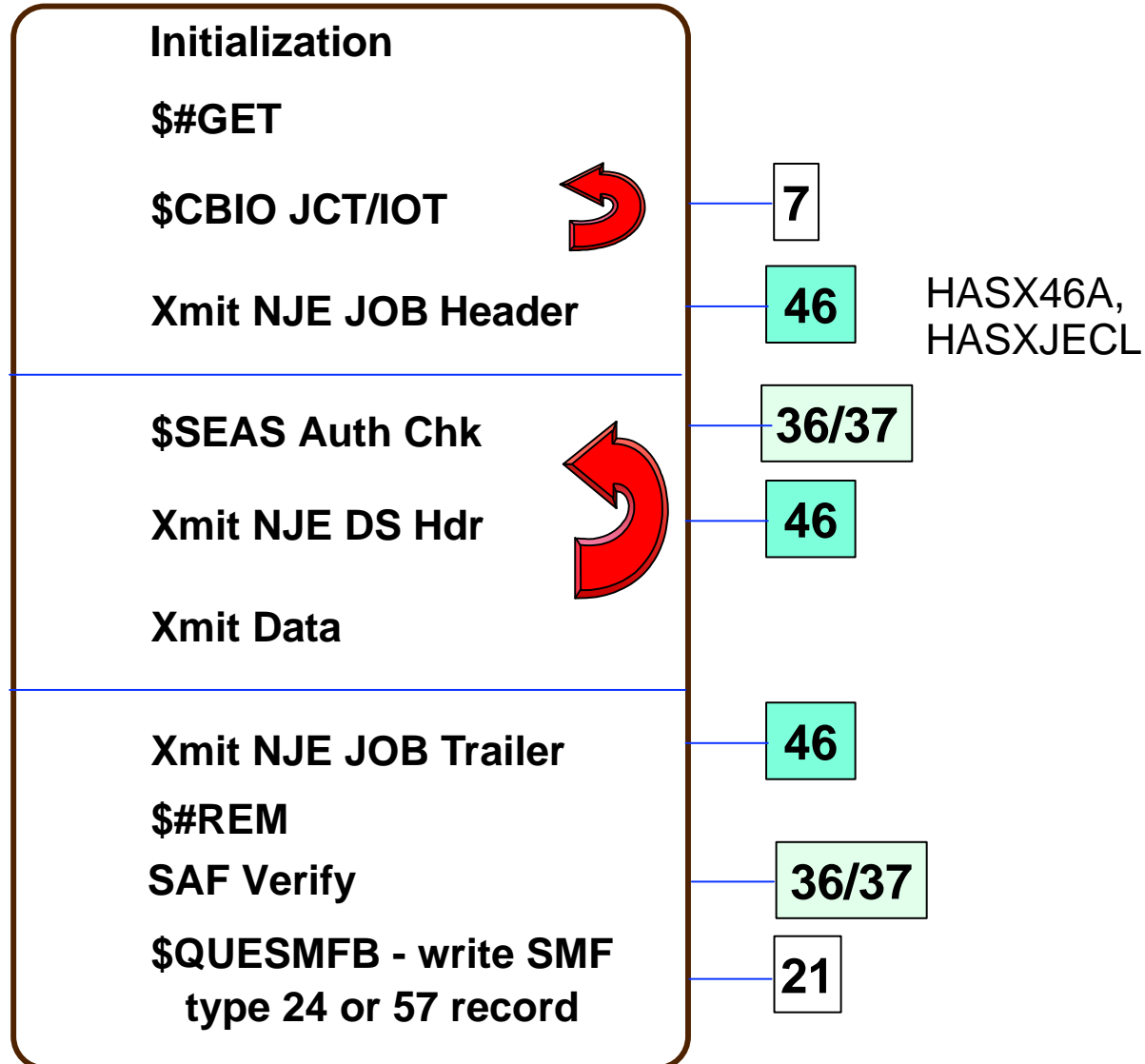

NJE & Spool Offload Receivers



HASPNSR

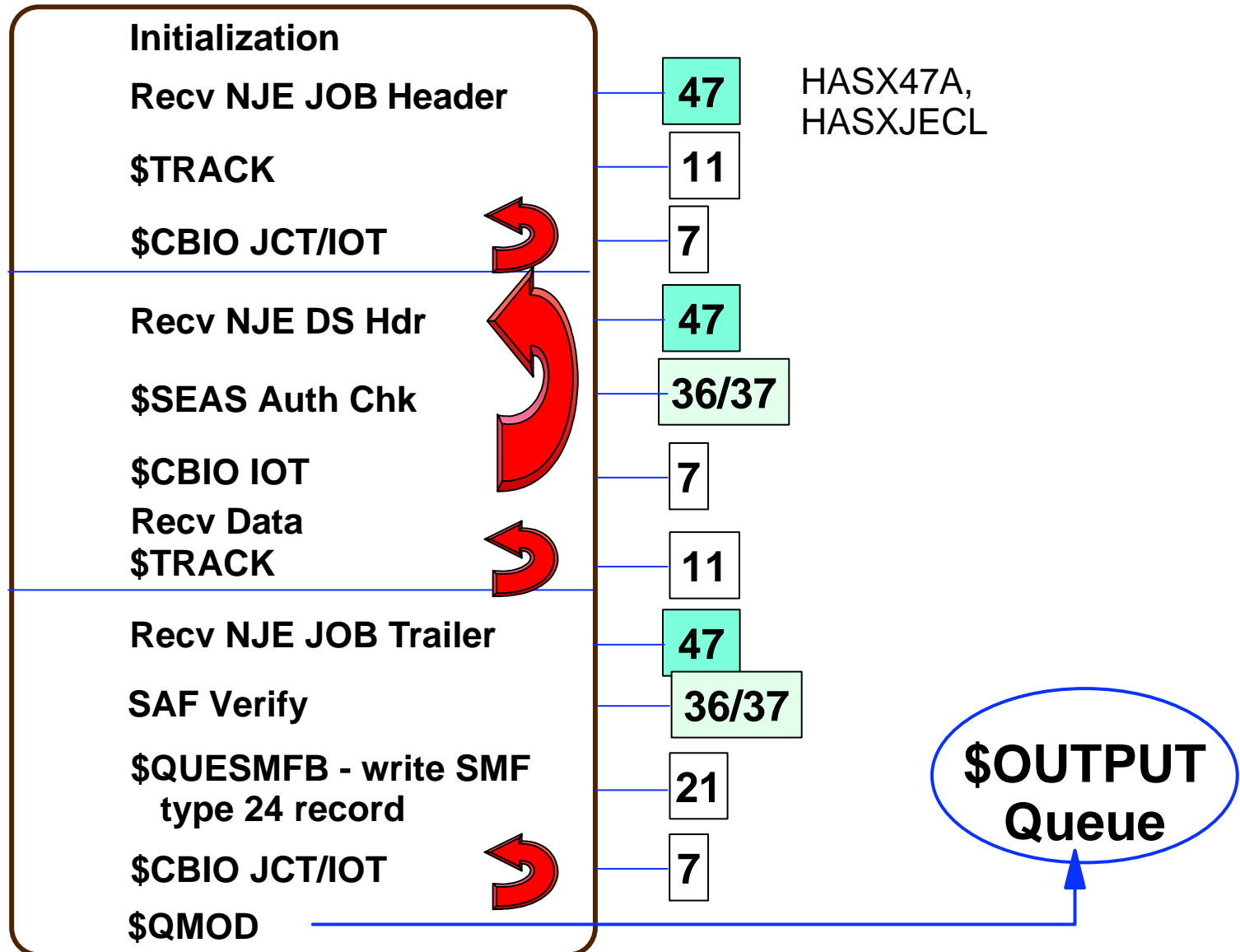

NJE Transmitters - the future



HASCNJST

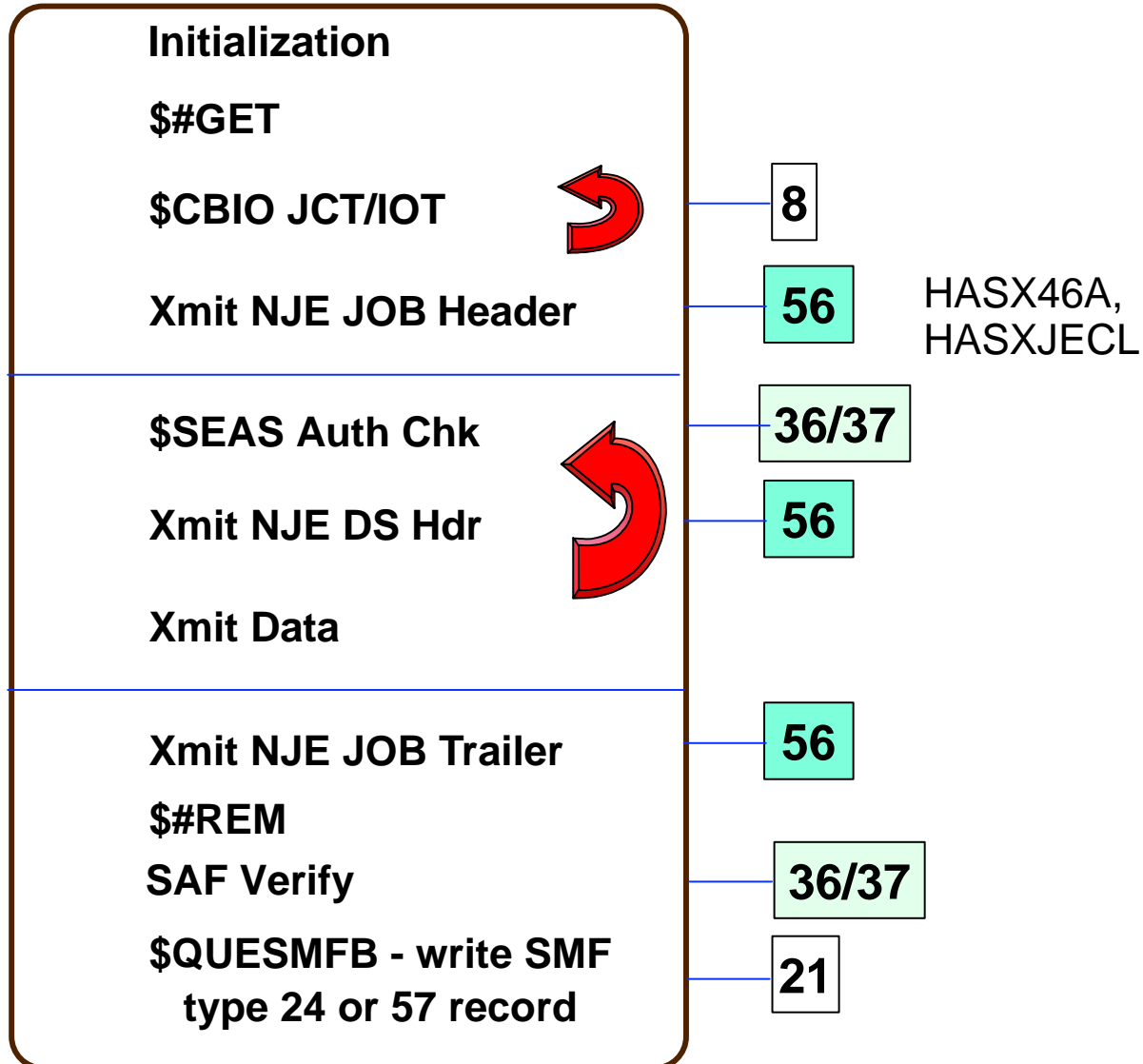

NJE Receivers - the future



HASCNJSR

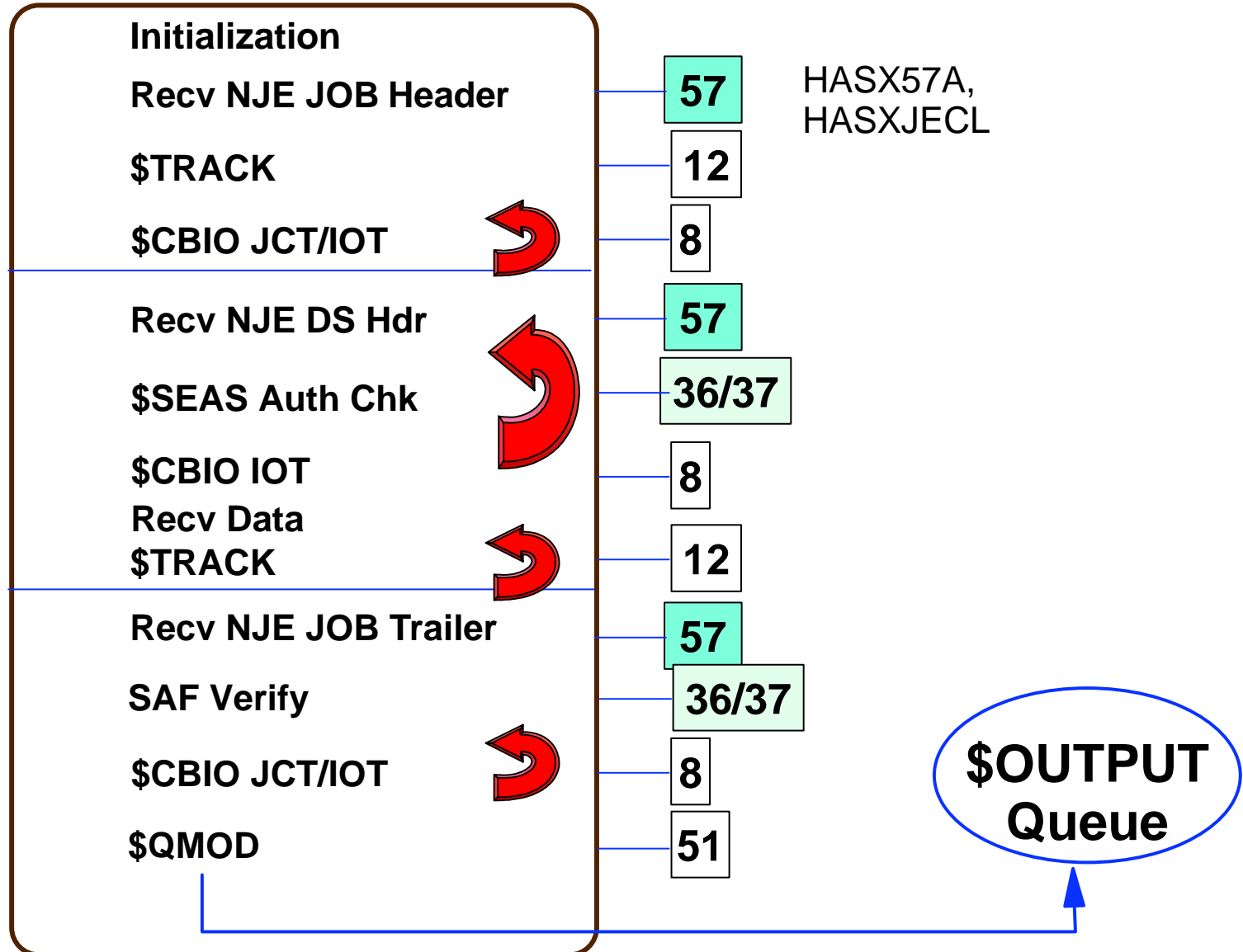

Purge Phase



HASPTRAK

HASPVPRG

\$QGET

14/49

\$CBIO Read JCT

7

\$PURGE

36/37

Get SMF Buffer

Build JMR

Move JCT into
SMF 26 record

Format SMF26 record

\$QUESMFB

\$DORMANT

HASPNUC

\$QUESMFB

Queue SMF Buf

21

\$POSTQ

Return to VPRG

TCB

HASPMISC

HASPACCT

SMFEXIT

IEFUJP

SMFWTM

\$\$POST maintask

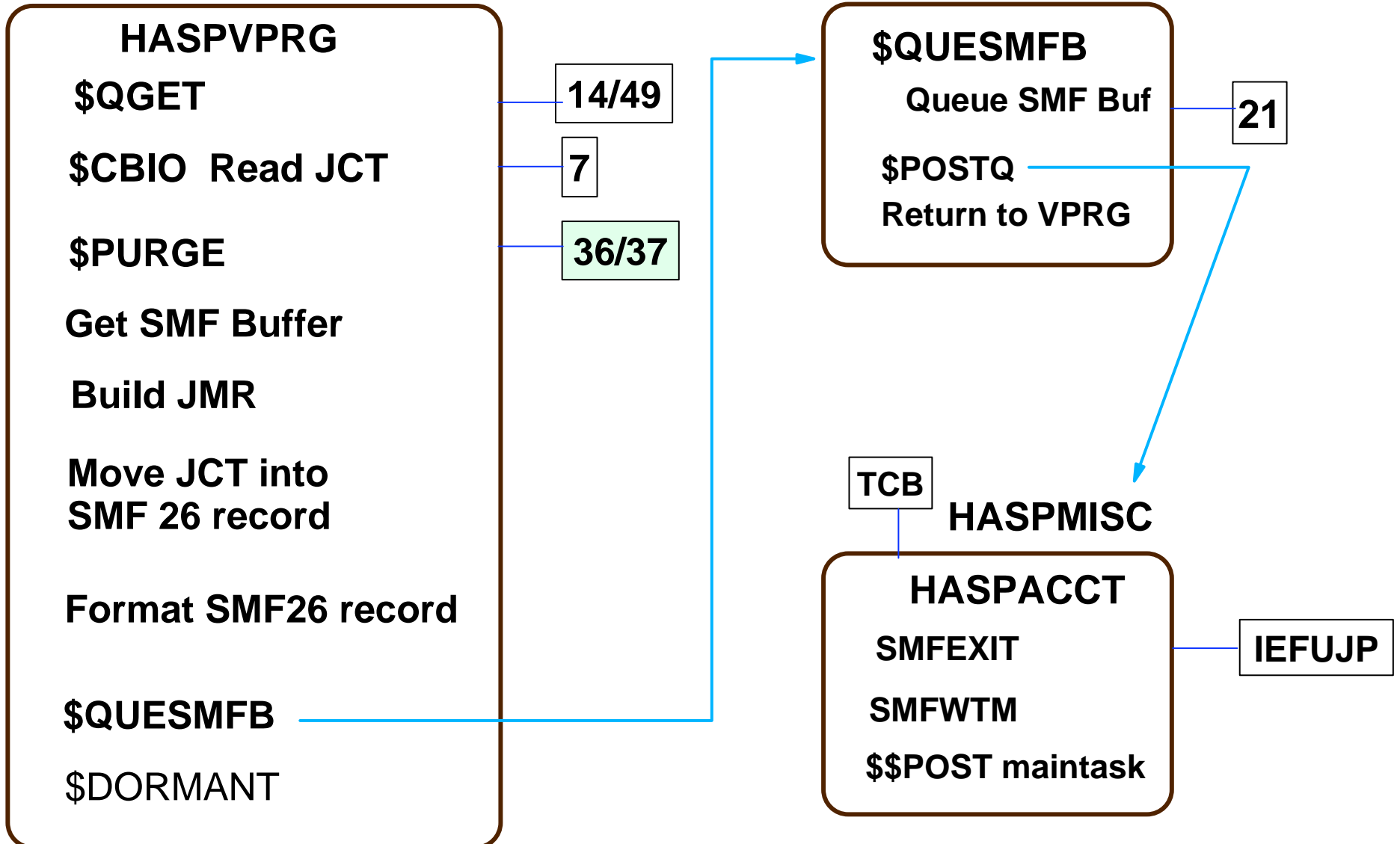

Job-related Control Blocks



■ Checkpointed Control Blocks

- **\$JQE** - Job Queue Elements - access w/\$DOGJQE
- **\$JOE** - Job Output Elements - access w/\$#GET, \$#....

■ Spool Resident Control Blocks

- **\$JCT** - Job Control Table (Addr.usually passed in \$XPL)
 - **\$Pddb** - Peripheral Data Definition Block (1/Data Set)
 - **\$IOT** - I/O Table (contains PddbS for a Job)
 - NJE Job & Data Set hdrs (only created if transmitted)
- Generally passed to exits in parameter list (XPL)

Coding Exits



Basic Constructs



- Code JES2 exits in assembler
- Some basic constructs are common to all exits

```
                COPY  $HASPGBL
                $MODULE

ROUTINE1 $ENTRY
          $SAVE
          $ESTAE
...
          $RETURN

          $MODEND
```

JES2 Exit Data Structures

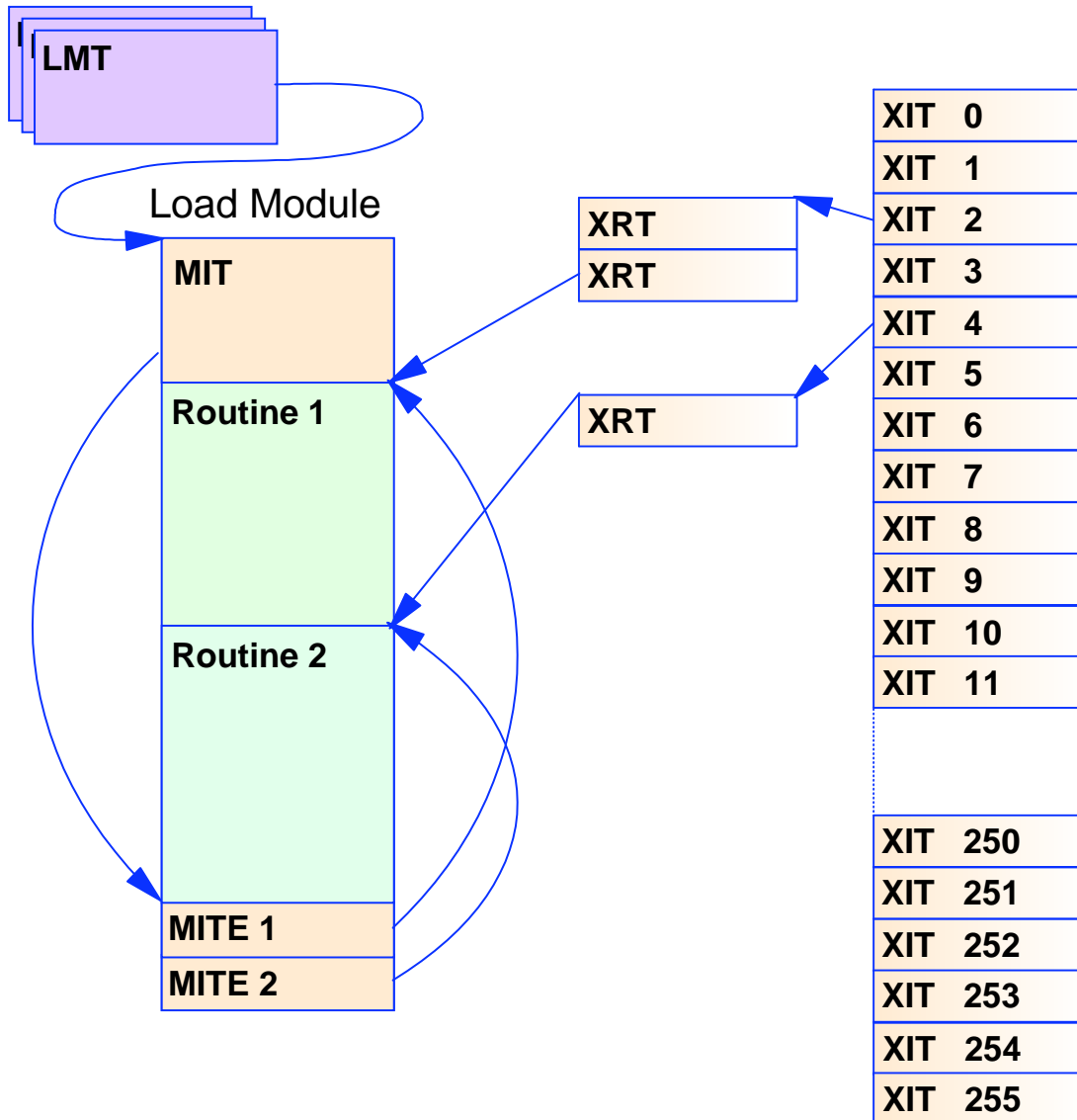

MIT

- Module Information Table
- Created by \$MODULE

MITE

- Module Information Table Entry
- Created by \$MODEND
- One MITE per \$ENTRY point

LMT

- Load Module Table
- Created by LOAD initialization statement
- Pointer and attributes of load module

XIT

- Exit Information Table
- Information about exit

XRT

- Exit Routine Table
- List of routines called by exit
 - Name and Address

\$HASPGBL



- **COPY \$HASPGBL**
- Includes and initializes assembler variables that are required by later JES2 macros
 - **&J2VERSN SETC 'z/OS 1.5'**
 - **&J2PLVL SETA 35**

```

      AIF (&J2PLVL LT 35).SKIP1
      <code that only runs on JES2 z/OS 1.5 and up>
      .SKIP1 ANOP
    
```

 - **&J2SLVL SETA 0**
- Includes assembler GBLx statements for other variables that may be referenced in open code
 - **GBLC &ANVIRON**
 - **GBLC &J2SECTN**

\$MODULE



■ \$MODULE:

- Defines what JES2 environment the exit will run in
 - ▶ Affects register conventions
 - ▶ Affects what you're allowed to do
- Defines what mappings are to be included
 - ▶ Includes all JES2 mapping macros
 - ▶ Includes many MVS mapping macros
 - ▶ Automatically resolves mapping dependencies
- Defines RMODE, reentrancy
- Defines default print options and TITLE
- Creates MIT (Module Information Table)
 - ▶ Contains information validated when module is **LOAD**ed

Environments



- **\$MODULE ENVIRON=** Keyword
 - Assembly environment (**&ANVIRON**)
- **If you get this wrong, the exit will not work!!**
- Helps catch coding errors
 - MNOTE from unsupported macro services (\$CKPT, etc).
- **ENVIRON=** should be one of:
 - **JES2** - JES2 main task
 - **SUBTASK** - JES2 subtask
 - **USER** - JES2 USER environment
 - **FSS** - Functional subsystem environment

ENVIRON=JES2



- **ENVIRON=JES2** - JES2 Main Task
- JES2 address space, JES2 Main task
- **R11** = HCT address
- **R13** = PCE address
- JES2 Main Task Serialized
 - Only one PCE runs at a time
- Routine should reside in private storage
 - **LOAD(routine) STORAGE=PVT**
- Routine may reside in common storage
 - Why use up CSA unnecessarily?
 - Can't refresh routine on a hot start

ENVIRON=JES2



- Avoid MVS waits!
 - Use **\$WAIT** instead
 - ▶ **Note that some exits do not allow \$WAIT!**
 - Use JES2 equivalent services that do not MVS WAIT
 - ▶ **\$WTO**, etc.
 - If calling service which can MVS WAIT, consider using **\$SUBIT** to \$WAIT the PCE while a JES2 subtask does the MVS WAIT.
 - Exceptions - JES2 Initialization/Termination (Exits 0, 19, 24, 26)
 - ▶ JES2 dispatcher not enabled, so DON'T \$WAIT
 - ▶ **ENVIRON=(JES2,INIT)** can be used in 0, 19, 24
 - ▶ **ENVIRON=(JES2,TERM)** can be used in 26

ENVIRON=SUBTASK



- **ENVIRON=SUBTASK** - JES2 Subtask environment
- JES2 address space, non-main task
 - MVS WAIT can be done
 - \$WAIT not allowed
- **R11** = HCT
- **R13** = DTE
- Multi-tasking considerations apply!
 - Multiple subtasks can simultaneously be in subtask
 - Reentrancy is very important
- Routine should reside in private storage
- Routine may reside in common storage

ENVIRON=USER



- **ENVIRON=USER** - JES2 USER Environment
- Any address space, any task
- **R11** = HCCT
- **R13** = Available save area
- Multi-tasking considerations:
 - Multiple tasks in multiple address spaces may be in exit simultaneously
 - Reentrancy very important
- Routine **MUST** reside in common storage
 - **LOAD(routine) STORAGE=CSA**
 - **LOAD(routine) STORAGE=LPA**
- Exits may get control when JES2 is down!

ENVIRON=FSS



- **ENVIRON=FSS** - Functional subsystem environment
- FSS address space
- **R11** = HFCT
- **R13** = Save area
- Routine **MUST** reside in common storage

\$ENTRY



- **\$ENTRY** - Generates entry point
 - Entry point defined (and MITE)
 - Eyecatcher ('**\$\$\$\$*routine-name***')
 - Using on register(s) specified for **BASE=**
 - Optionally, sets base registers (**SETBASE=YES**)
 - Optionally, generates \$SAVE (**SAVE=YES**)
 - ▶ Trace \$SAVE via **SAVE=(YES,TRACE)**
 - Can specify **CSECT=YES** to put each entry point in a separate CSECT
 - ▶ Data isolation
- Alternatively, specify **ENTRIES=(*routine*, *routine*)** on **\$MODULE**
 - Generates ENTRY and MITE only

\$SAVE/\$RETURN



■ \$SAVE

- Saves registers on entry
- Different expansions, depending on environment!
 - ▶ **\$HASP095 CODE=\$S02**

■ \$RETURN

- Returns to caller
- RC= - specifies a return code
 - ▶ Return code can be coded explicitly (**RC=0**)
 - ▶ Return code can be in register (**RC=(R15)**)

\$ENTRY



■ Example \$ENTRY expansion

```

MYRTN      $ENTRY BASE=(R12,R8),SAVE=(YES,TRACE)
+          ENTRY MYRTN                <--- Entry Statement
+MYRTN     DS      0D                  <--- Entry Point
+          USING MYRTN,R12,R8         <--- Using for BASE=
+          J      $EE2185
+          DC     C'$$$$'              <--- Eyecatcher
+          DC     CL8'MYRTN'
+$EE2185   STM    R14,R12,12(R13)      <--- $SAVE
+          L      R15,$PADDR
+          L      R15,P@GETSAVE-PADDR(R15)
+          BASR   R14,R15
+          J      $CAL2192
+          DC     AL1($SAVTRC,0)
+          DC     CL8'MYRTN'
+$CAL2192  DS      0H
+          LM     R14,R12,12(R13)
+          LR     R12,R15              <--- Set base registers
+          LR     R8,R12
+          AHI    R8,4096
  
```

\$MODEND



- Defines end of module
- Generates MITEs for each \$ENTRY
 - Names and entry points of all routines defined via \$ENTRY
 - LOAD init statement can identify all routines defined in module for inclusion via EXITnn ROUTINES=
 - Entry points that LOAD uses

```

                COPY  $HASPGBL
MYMOD          $MODULE ENVIRON=JES2
MYRTN          $ENTRY  BASE=(R12),SAVE=YES
                $RETURN RC=0
                ...
                $MODEND
+              ...
+              DC    CL8 'MYRTN'                <--- MITE for MYRTN
+              DC    A(MYRTN),AL1(0,MITENVJ,0,0)
+              DC    AL2(0),AL1(0,0)
+              ...
  
```

Packaging



- Package exits for one function together
 - For example, **HASXJECL**
 - ▶ \$EXIT 1 to print data on separator page
 - ▶ \$EXIT 4 to obtain separator page data from JCL
 - ▶ \$EXIT 46,47 to transmit separator page data across NJE
- Package unrelated exits separately
 - For example
 - ▶ \$EXIT 5 to create 2 separate commands
 - ▶ Different routine for each
 - ▶ Separate load modules

\$ENVIRON



- **\$ENVIRON** - changes the current assembly environment (**&ANVIRON**)
- For example
 - Need an exit 6 and an exit 44 to accomplish a function in the converter

– Code like this:

```
                $MODULE ENVIRON=JES2
EXIT44          $ENTRY
                ...
                $ENVIRON SET,ENVIRON=SUBTASK
EXIT6           $ENTRY
                ...
                $MODEND
```

- ***BE CAREFUL!!! Remember that if ANY routine is ENVIRON=USER or ENVIRON=FSS, it needs to be in common storage!!!***

Extending data areas



- **"Unsupported"** way - modify mapping macro
 - IBM does not recommend expanding control blocks
 - Consider:
 - ▶ Effects of enabling and disabling exits
 - ▶ Effects on checkpointed or spool control blocks (**COLD** start implications!)
 - ▶ Which base JES2 modules require reassembly
 - Beware of using "reserved" fields
 - ▶ IBM may reclaim them later
 - ▶ There may be an intended purpose for reserved space in a particular place (e.g. job number)
 - Keep IPCS formatters in synch
 - May interfere with LEVEL2 resolution of unrelated problems for dumps sent to IBM

Extending data areas



- "Supported" ways
 - **\$UCT** control block
 - ▶ Obtain in exit 0, store address in \$UCT field
 - ▶ Can contain table pairs, pointers to other CBs
 - **\$USER_n**, **PCEUSER_n**, **DCTUSER_n**, **CCTUSER_n** fields
 - ▶ Can be used as pointers to your own area if not enough space
 - **\$JCTX** services (JCT)
 - ▶ **\$JCTXADD**, **\$JCTXGET**, **\$JCTXEXP**, **\$JCTXREM**
 - **\$BERTTABS** (JQE and CAT)
 - ▶ **\$BERTTAB CBOFF=***
 - ▶ **\$DOGBERT ACTION=GETOFFSET**

Enabling your exit



- **LOADmod** initialization statement
 - Loads your load module
 - ▶ STEPLIB, LNKLIST, or LPA
 - **LOADmod(*name*) STORAGE=**
 - ▶ **PVT** - Module is loaded into JES2 private storage
 - ▶ **CSA** - Module is loaded into common storage
 - ▶ **LPA** - Version of module in LPA used
 - ▶ ENVIRON=USER or FSS cannot go in private
- **\$D LOADMOD(*name*)** displays
 - **ADDRESS** and **LENGTH**
 - **ROUTINES** and **TABLES**
 - **STORAGE** and **RMODE**

Enabling your exit



- **EXIT(*nnn*)** statement
 - **ROUTINES=(*routine-name*,*routine-name*)**
 - ▶ Lists all routines to be called by exit
 - **ENABLE/DISABLE**
 - ▶ Whether exit is initially enabled or disabled
 - ▶ Default: ENABLE if you specified routines
- **\$TEXTIT*nn*,ENABLE** or **\$TEXTIT*nn*,DISABLE**
 - Enable/disable exits
 - Exit level only (not individual routines)
 - Consider implementing router exits to disable individual functions

Router exits



- Old way
 - **EXIT(5) ROUTINES=(rtn1,rtn2,rtn3)**
 - **\$TEXIT5,DISABLE** disables all 3 routines
- New way
 - **EXIT(5) ROUTINES=(router1,router2,router3)**
 - **EXIT(253) ROUTINES=(rtn1)**
 - **EXIT(254) ROUTINES=(rtn2)**
 - **EXIT(255) ROUTINES=(rtn3)**

 - Routine **router1** consists of standard linkage and invokes **\$EXIT 253** with appropriate parameters
 - Routines **router2** and **router3** do likewise

 - **\$T EXIT253,DISABLE** disables only routine **rtn1**

Enabling Exit 0



- Enabling exit 0 is a special case
 - Called **BEFORE** any EXIT statements can be processed
 - Load module name must be **HASPXIT0**
 - All routines must begin with the characters **EXIT0**
 - Routines are called in the order found in MITE
 - **\$DEXIT(0)** displays routines that were called by exit

Debugging

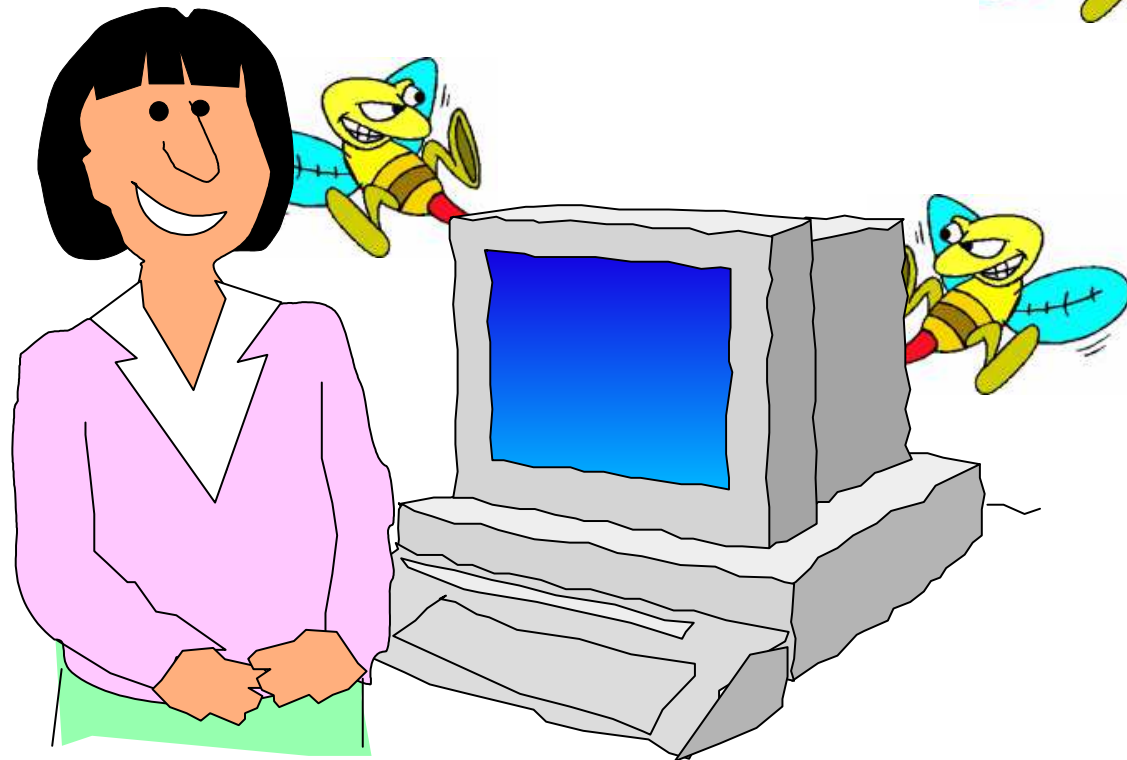

Debugging aids



■ \$TRACE 13

- Traces every exit point on entry and exit

```
17.43.12.79 ID = 13 $EXIT      STC00009      STCINRDR  0667B0D0
# 4: ENVIRON= JES2 LABEL= RXITCCA PRE INVOCATION
R0-R7 = 00000004 0667B200 0667B428 00006000 ...
R8-R15 = 00000000 00000000 06955000 00007000 ...
```

```
17.43.12.79 ID = 13 $EXIT      STC00009      STCINRDR  0667B0D0
# 4: ENVIRON= JES2 LABEL= RXITCCA POST INVOCATION
LAST ROUTINE CALLED = DIAGX04 R15-R1 = 00000000 00000004 ...
```

```
17.43.12.81 ID = 13 $EXIT      ASID  0017
# 36: ENVIRON= USER LABEL=EXIT6RTN PRE INVOCATION
R0-R7 = 00000000 001344E0 83DA33A4A 03A97810 ...
R8-R15 = 001340D0 00000000 03C490000 00006000 ...
```

- Was the input what was expected?
- Are multiple callers in exit simultaneously?

Debugging aids



- \$SAVE/\$RETURN \$TRACE ids
 - 1 and 2 - JES2 and FSS environments
 - 11 and 12 - Only \$SAVE/\$RETURN calls for specific PCE types
 - 18 and 19 - USER and SUBTASK environments

```

12.59.59.08 ID = 1 $SAVE      COMM      066690E8  PRKEYWRD
R14-R1 = 800F338E 000F4E70 00000000 7F6F100C
12.59.59.08 ID = 2 $RETURN   COMM      066690E8  PRKEYWRD
R14-R1 = 800F338E 00000000 00000000 7F6F100C

14.07.06.28 ID = 18 $SAVE     ASID 012E  USERSUB
R14-R1 = 85EE8770 05F03C70 7F706AD8 7F6FC58C
14.07.06.29 ID = 19 $RETURN   ASID 012E  USERSUB
R14-R1 = 85EE8770 00000000 7F706AD8 7F6FC58C

```

- What services were called by exit?
- What point in processing was exit called?
- What was happening at same time as exit?

Debugging aids



■ \$HASP088 message

```

$HASP088 ----- JES2 ABEND ANALYSIS -----
$HASP088 FMID      = HJE7703      LOAD MODULE = HASJES20
$HASP088 SUBSYS    = JES2  OS 2.10
$HASP088 DATE      = 2001.179      TIME      = 15.14.02
$HASP088 DESC      = PROTECTION EXCEPTION
$HASP088  MODULE    MODULE      OFFSET  SERVICE  ROUTINE    EXIT
$HASP088  NAME      BASE        + OF CALL LEVEL  CALLED      ##
$HASP088  -----  -----      -----  -----  -----  ---
$HASP088 *UNKNOWN  00000004 + 000000  UNKNOWN  *ABEND SOC1  7
$HASP088 HASTDIAG  00189000 + 009124  NONE     XIT7MSG      7
$HASP088 HASPNUC   00007000 + 00742C  NONE     DIAGX07      7
$HASP088 HASPNUC   00007000 + 0079F8  NONE     $JESEFF
$HASP088 HASPNUC   00007000 + 0076B0  NONE     CBMWRTN
$HASP088 HASPRDR   000DC000 + 00430C  OW44439  $CBIOM
$HASP088 HASPRDR   000DC000 + 007DCE  OW44439  RWRTJOB
$HASP088 HASPRDR   000DC000 + 000C94  OW44439  HASPRJCS
$HASP088 PSW      = 071C0600 00000004 ILC = 2  IC = 01
$HASP088 ASID     = 0017 (HOME) 0017 (PRIM) 0017 (SCND)
$HASP088 PCE      = STCINRDR (066790D0) STC00007 DEALLOC
$HASP088 R0       = 06618284 06953000 002921B0 00000007
$HASP088 R4       = 06679400 06953000 06953000 06953000
$HASP088 R8       = 800E030C 000E3A48 06618284 00007000
$HASP088 R12      = 001994A0 066790D0 001995B0 00000000
$HASP088 -----
  
```

Debugging aids



■ Finding your exit in storage

– On a live system:

- ▶ \$D MODULE command

`$dmodule(hastcdia),long`

```
$HASP468 MODULE(HASTCDIA) ADDRESS=00B3B000,ASSEMBLY=(01/23/01,
$HASP468          14.25),ENVIRON=USER,EXITPTS=( ),
$HASP468          FMID=HJE7703,IBMJES2=SAMPLE,
$HASP468          LASTAPAR=NONE,LASTPTF=NONE,
$HASP468          LENGTH=0010D0,LOADMOD=HASTCDIA,
$HASP468          MACLEVEL=6,
$HASP468          ROUTINES=(DIAGXITC=00B3B050,
$HASP468          DIAG3637=00B3C0D0,RMTWAIT=00B3C790),
$HASP468          SPLEVEL=CHECK,
$HASP468          VERSION=OS 2.10,UVERSION=
```

– In a dump

- ▶ \$MIT formatting
- ▶ \$XIT/\$XRT formatting

Debugging aids



- **SLIP** in routine to verify flow
- Obtain dumps at strategic points in your exit
 - **SLIP** dump
 - Zap bad opcode (X'0000')
 - **\$ERROR**
 - **\$DISTERR**
- Use IPCS to:
 - Verify register contents
 - Verify data structures
 - Look for possible overlays (PCE analysis, etc.)
 - Look for possible storage leaks (\$GETWORK analysis)

Summary



- Research your exit thoroughly
 - Investigate alternatives
 - Understand the costs involved
- Understand JES2
 - Different JES2 environments
 - Point in processing of exit
 - What exit can and cannot do
- Test your exit thoroughly
 - Understand all possible inputs and outputs
- Protect your production system
 - Build in recovery
 - Know effects of disabling/re-enabling exit