



System z Enables Solutions For A Smarter Planet

Smart Work On System z

Service Oriented Finance Automated Its Loan Processing In 2008

We automated our loan processing with WebSphere and it's great! We reduced loan processing time and our loan volumes increased 59%.



Service Oriented Finance CEO, 2008

Changing Business Conditions

But times have changed. We need to be more careful who we loan money to.



Service Oriented Finance CEO, 2009

Change The Rules, Not The Process

It sounds like we need a new business process!



**Service Oriented Finance
CIO**

You don't have to replace the process – simply adjust it!



IBM

Service Oriented Finance Automated Their Loan Process With WebSphere On System z

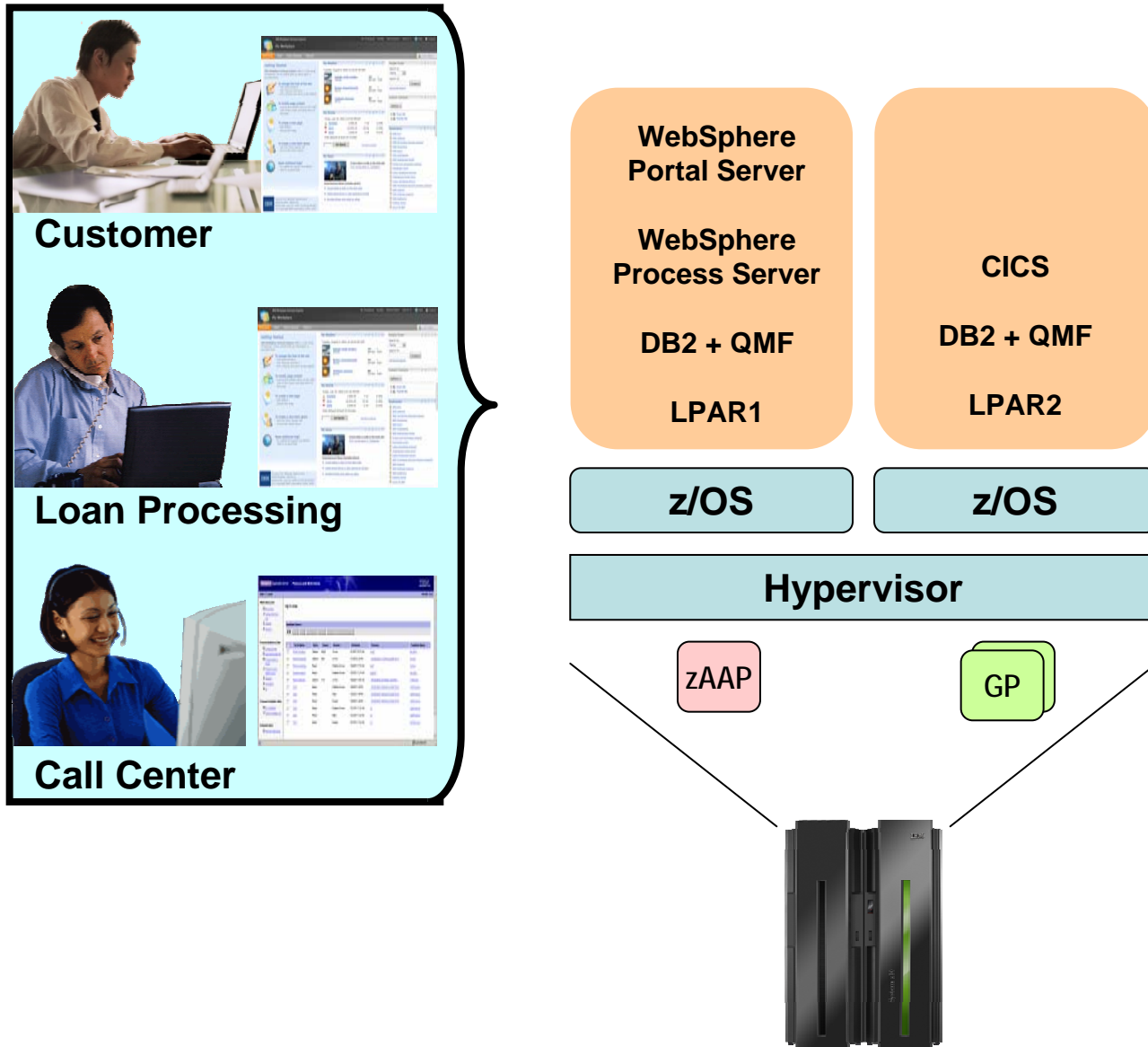

- System z:**
- Lowest cost
 - Performance from co-location
 - Quality of service

The Current Loan Process

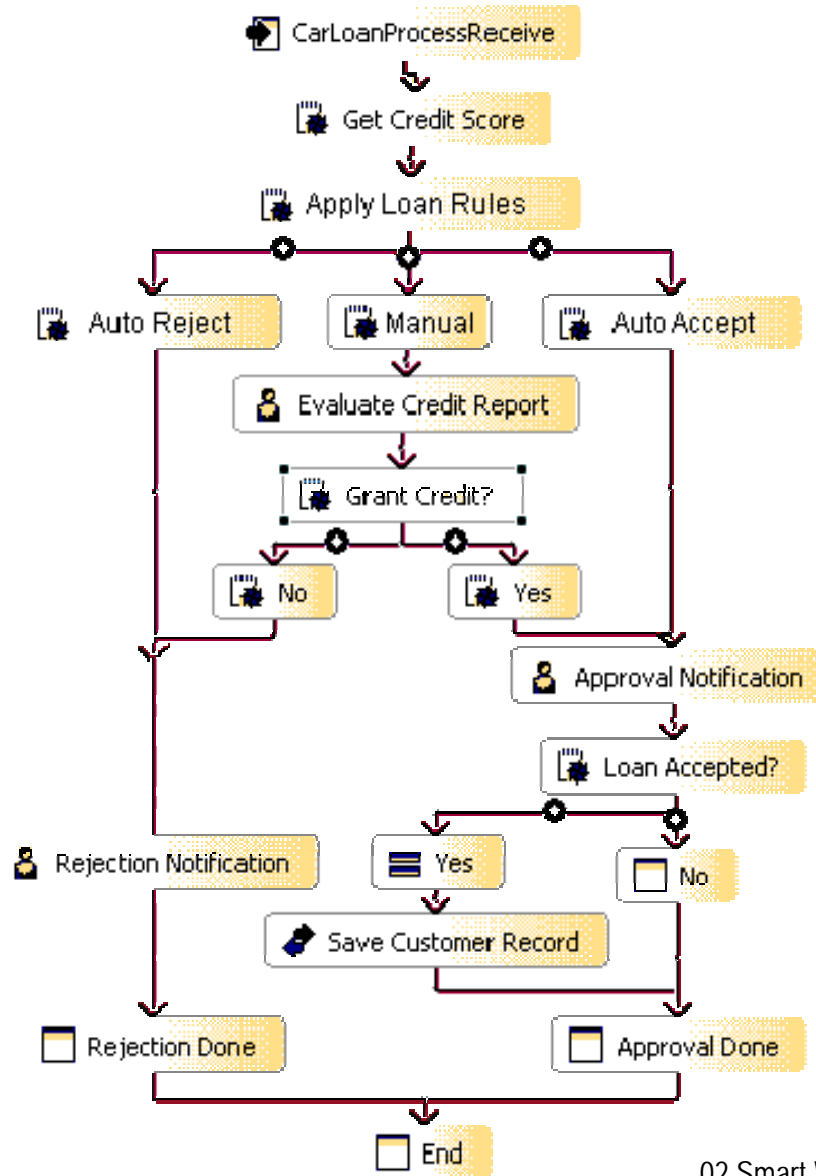

Key Features:

- Automated process management reduces processing time and eliminates paper
 - ▶ Efficient inclusion of human tasks, such as manual approval
 - ▶ Automatic access to back end systems
 - ▶ Instant status and tracking of each loan application
- System z is the lowest cost deployment platform

DEMO: The Current Loan Process



Tracy applies for a car loan from Service Oriented Finance

Car Loan Application

Loan Type: New Car Used Car

Loan Term: 24 36 48 60 72

Loan Amount Requested:

Application Type: Individual Application Joint Application

Customer #:

First Name:

Last Name:

Address:

City:

State:

Zip:

Phone:

Email:

What Changes Do You Need To Make?

We need to impose a maximum loan limit and require better credit ratings from applicants.



**Service Oriented Finance
CEO**



**Service Oriented Finance
CIO**

Business Rules Let You Adapt Quickly To Business Change

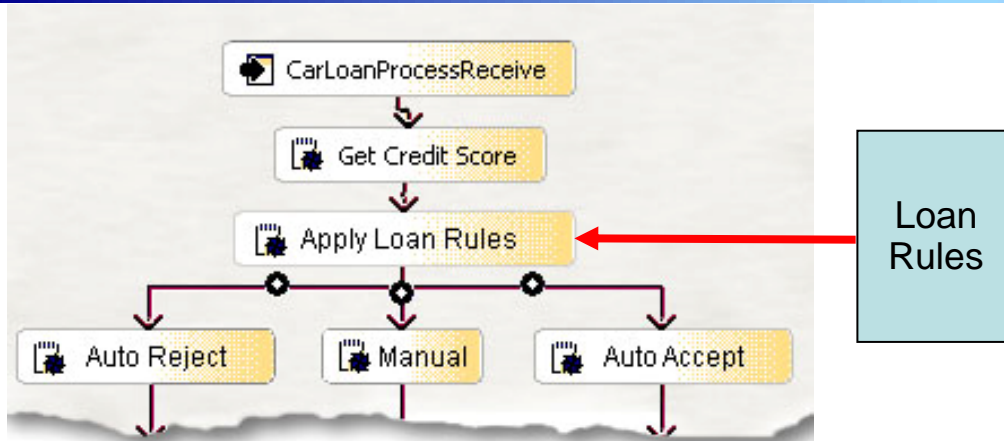

WebSphere Process Server externalizes business rules so they can be adjusted by business managers in production, without requiring development changes to the process

- ▶ Business rules are typically used to adjust thresholds
- ▶ Business rules easily changed with a browser after the process is deployed
- ▶ New rules take effect immediately without having to redeploy

Example: Change The Business Rules

Current car loan rules

- ▶ Default analysis result is **manual**
- ▶ If **credit score** is less than **500** analysis result is set to **auto reject**
- ▶ If **credit score** is greater than **700** analysis result is set to **auto accept**

New car loan rules

- ▶ Default analysis result is **manual**
- ▶ If **loan amount** is greater than **30,000** analysis result is set to **auto reject**
- ▶ If **credit score** is less than **650** analysis result is set to **auto reject**
- ▶ If **credit score** is greater than **720** analysis result is set to **auto accept**

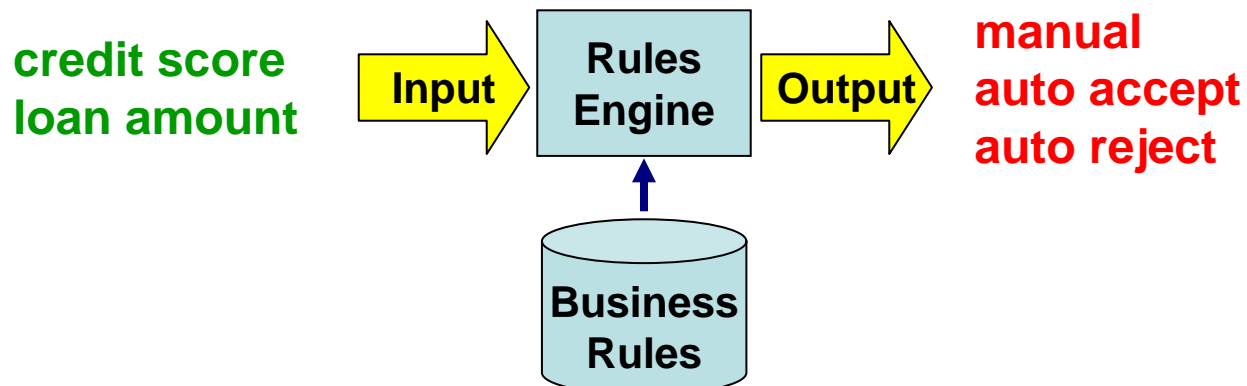

DEMO: Change The Rules

Welcome FENG | [Logout](#) | [Help](#)

> AnalyzeCreditScoreRuleGroup > executeRule

Edit Mode: AnalyzeCreditScoreRuleSet - Ruleset

Save Cancel Messages:

General Information

Last Published	Feb 24, 2009 07:45 (Local Time)	Status	*Original
Description	<input type="text"/>		

Rules

Close Template List

Name	Rule	Action
ManualRule1	Set default analysis result to <input type="text" value="Manual"/>	<input type="button" value="↓"/> <input type="button" value="Delete"/>
AutoRejectRule	If credit score is less than <input type="text" value="500"/> then analysis result is <input type="text" value="Auto Reject"/>	<input type="button" value="↓"/> <input type="button" value="↑"/> <input type="button" value="Delete"/>
AutoAcceptRule	If credit score is greater than <input type="text" value="700"/> , then analysis result is <input type="text" value="Auto Accept"/>	<input type="button" value="↑"/> <input type="button" value="Delete"/>

and click "Add" button.

Template	Rule	Action
Template_AutoRejectRule	<input type="checkbox"/> If credit score is less than <input type="text"/> then analysis result is <input type="text" value="Auto Reject"/>	<input type="button" value="Add"/>
Template_AutoAcceptRule	<input type="checkbox"/> If credit score is greater than <input type="text"/> , then analysis result is <input type="text" value="Auto Accept"/>	<input type="button" value="Add"/>
Template_MaxLoanRule	<input type="checkbox"/> <input type="text" value="MaxLoanRule"/> If loan amount is greater than <input type="text" value="30000"/> , set analysis result to <input type="text" value="Auto Reject"/>	<input type="button" value="Add"/>
Template_ManualRule1	<input type="checkbox"/> Set default analysis result to <input type="text" value="Manual"/>	<input type="button" value="Add"/>

1. impose a maximum loan limit
2. require better credit ratings

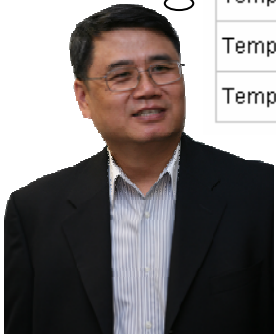

SOF's Loan Analyst, JC Feng, needs to change the rules

There Were Some Other Changes Made To The Process

We need a volunteer from the audience who has a mobile phone with text messaging. How about YOU?



DEMO: The Loan Application With The New Rules



Tracy applies for a car loan from Service Oriented Finance, after the change of rules

Car Loan Application

Loan Type: New Car Used Car

Loan Term: 24 36 48 60

Loan Amount Requested:

Application Type: Individual Application Joint Application

Customer #:

First Name:

Last Name:

Address:

City:

State:

Zip:

Phone:

Email:

With New Rules!

Making More Revisions To The Business Process

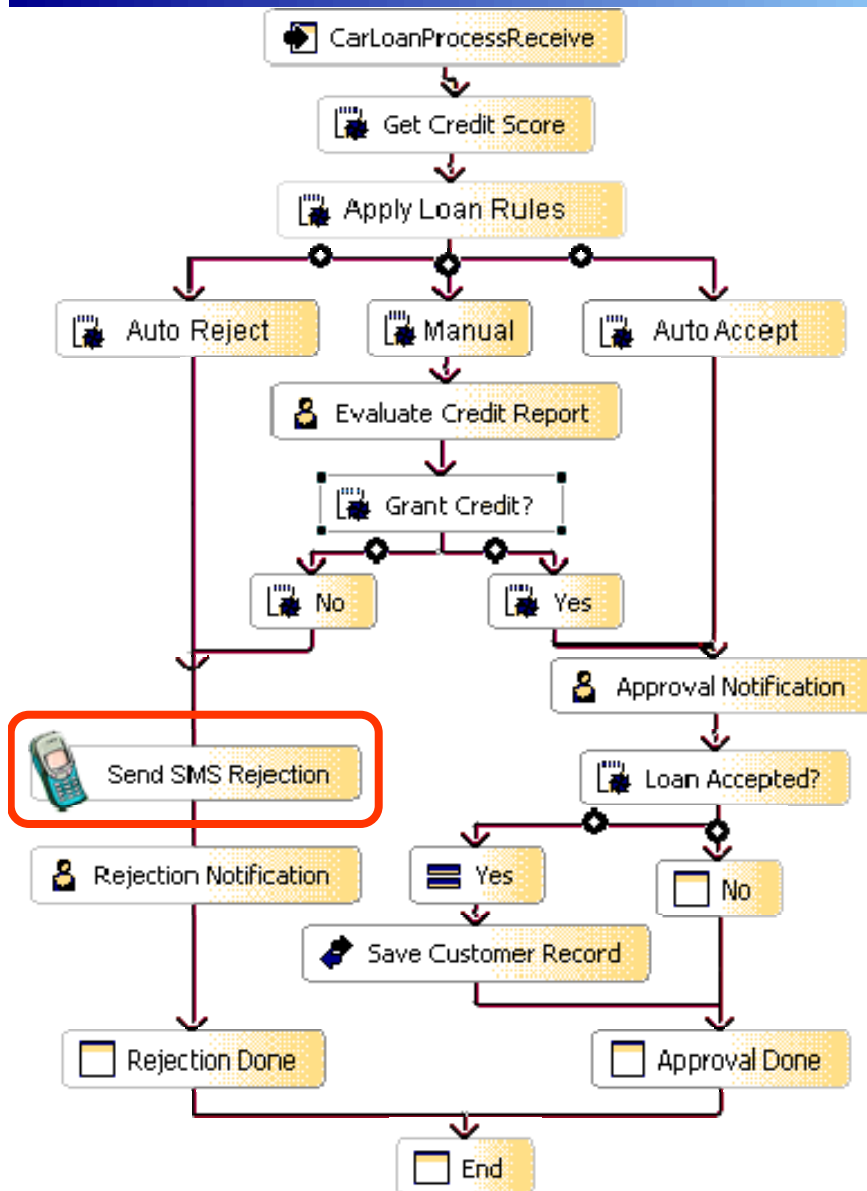

- In the demo we added a notification sent to a mobile phone via SMS using the phone number provided
- It's fast and easy to revise and redeploy an existing business process
 - ▶ Change the order of activity steps
 - ▶ Add one or more new activities
 - ▶ Use a different service provider
- Service Component Architecture (SCA) makes it easy
 - ▶ Tool can easily insert “send SMS alert” activity into flow

SOF Is Now An Agile Business, But There Are New Requirements



IBM can satisfy them!

SOA Approach Fits Into Existing Environments

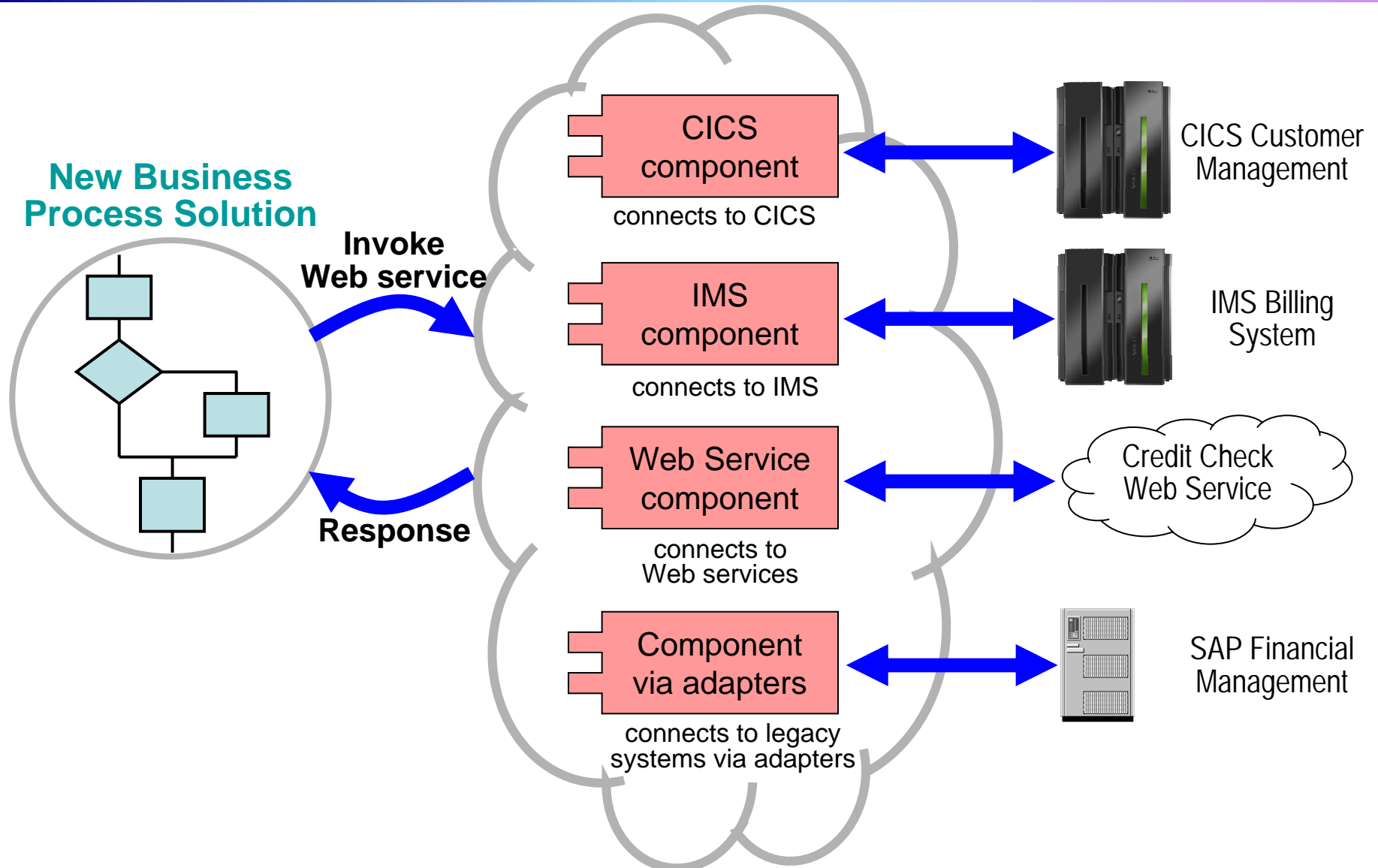

Service Component Architecture (SCA) Is The Foundation For Process Flexibility

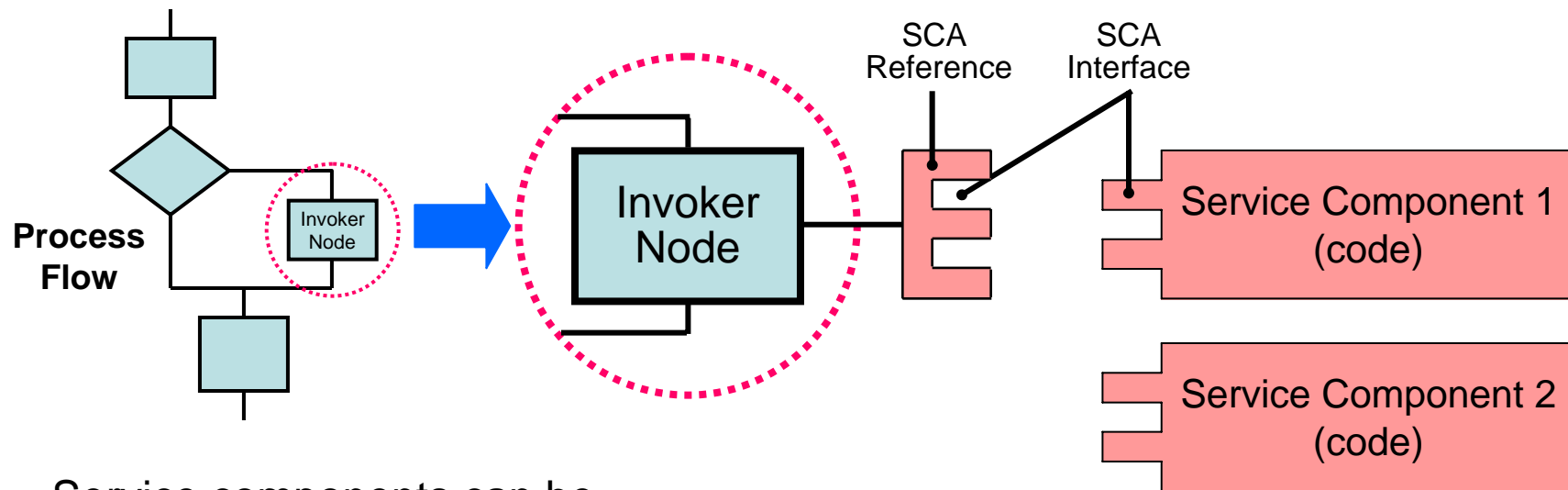

Service components can be

- ▶ Wired-in to the reference at assembly time
- ▶ Changed at assembly time
- ▶ And, as we'll see, selected or substituted at runtime

Types of service components

- ▶ EJB code
- ▶ Proxies to call Web services (e.g. a CICS transaction wrapped as a Web service)
- ▶ Proxies to send a task to a human
- ▶ Proxies that make decisions about what to do at run time



Process Flex Points Are Built On Service Component Architecture

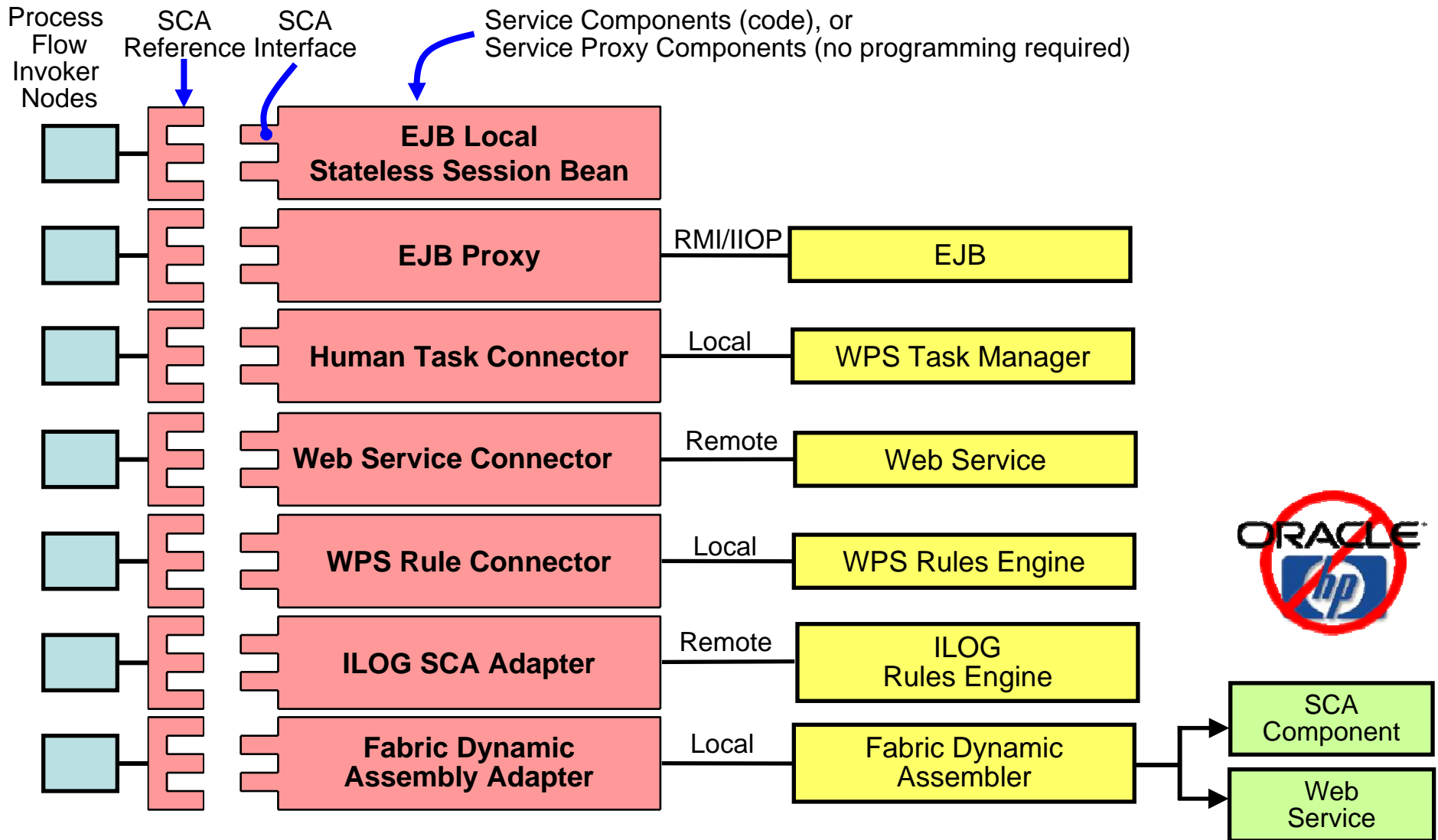

ILOG Captures Expertise As Business Rules For Re-Use In Business Processes

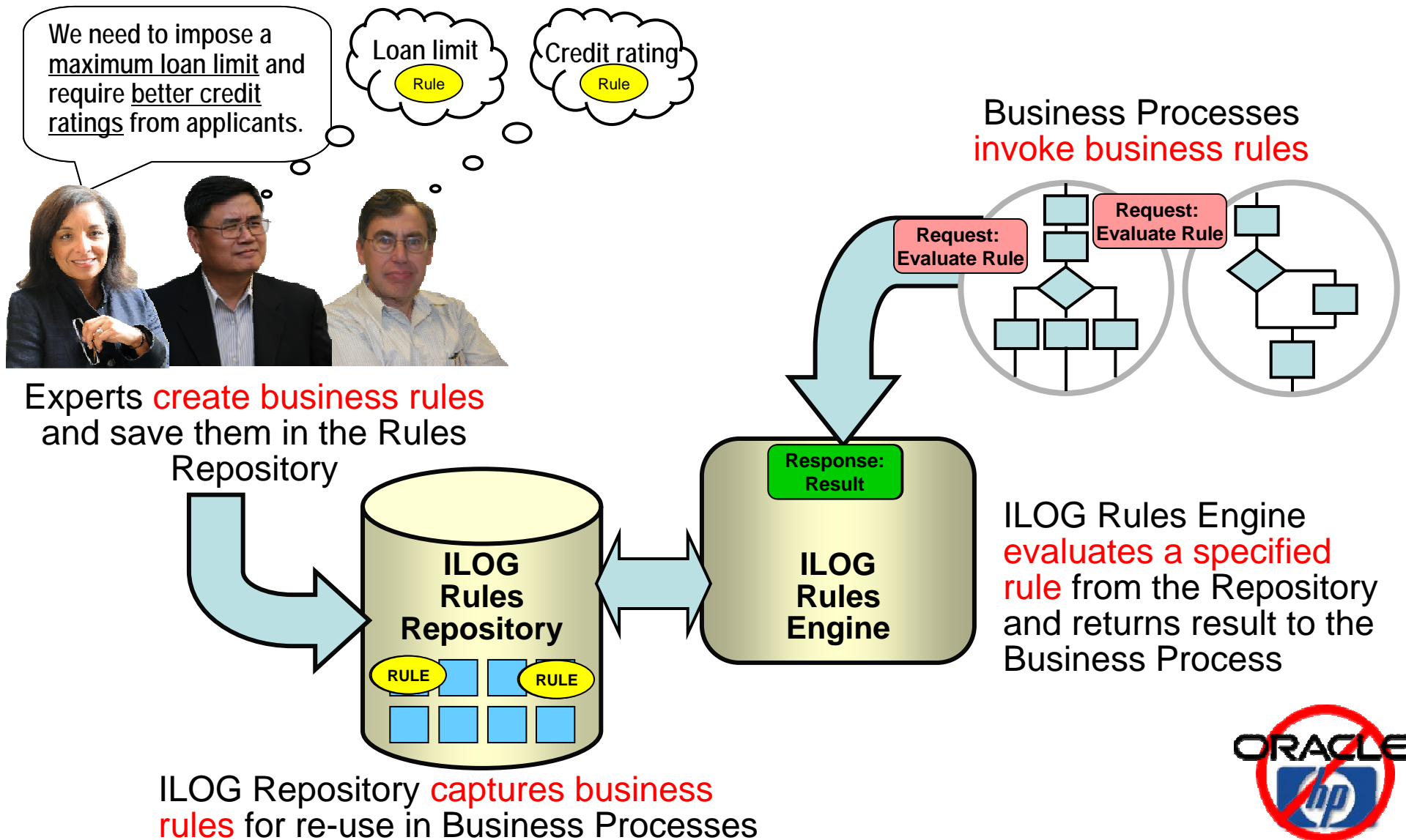

WebSphere Business Fabric Permits A Common Process To Be Adapted To Localities

- **PROBLEM:** Need to deploy same process worldwide, with localized differences
 - ▶ Customizing separate copies is cumbersome and costly, and complicates version control
- **SOLUTION:** Fabric supports a **common process** by selecting, **at runtime**, the service required for each request

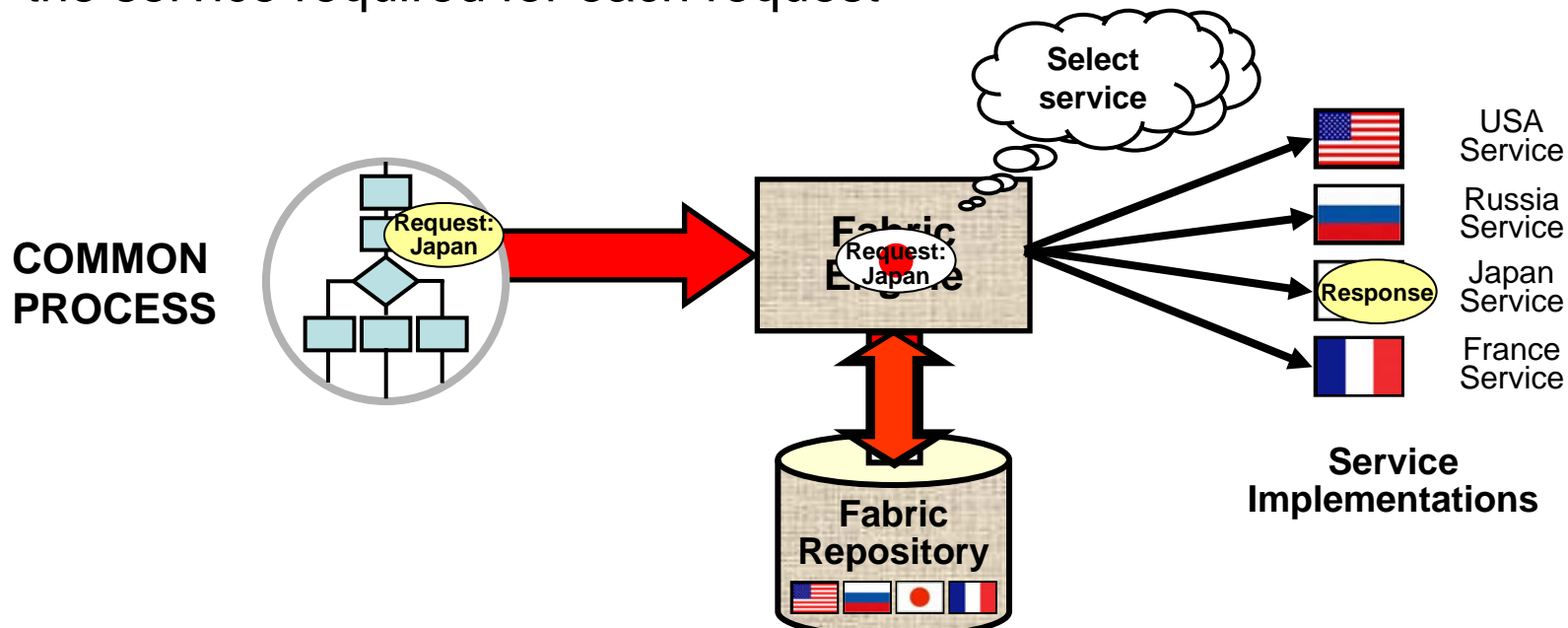
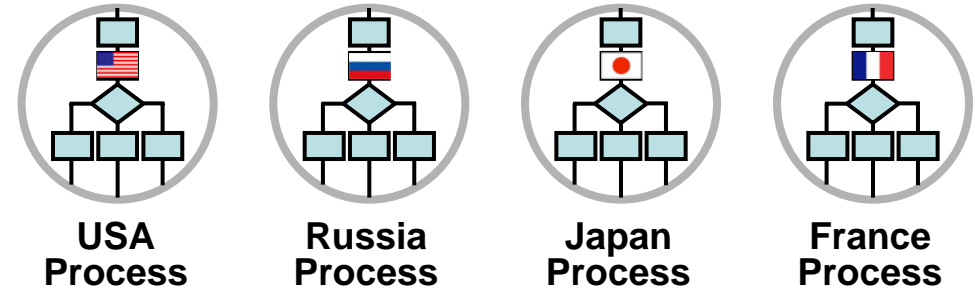

Enterprise Service Bus Provides Mediation Services At Runtime

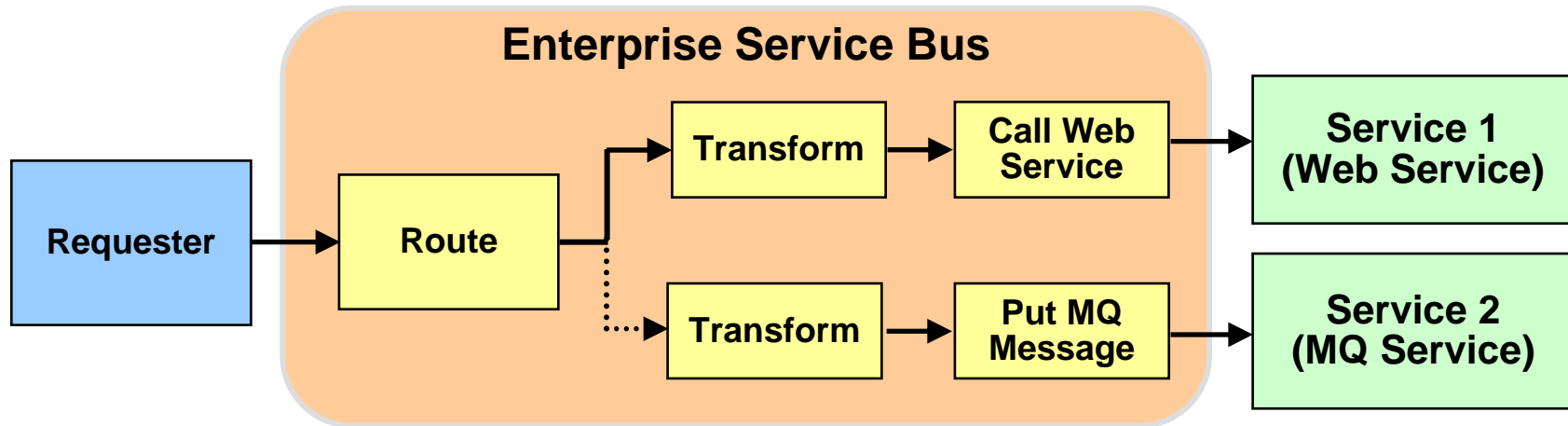

Runtime Mediation Services:

- ▶ Message Transformation
- ▶ Protocol Conversion
- ▶ Data Augmentation

Dynamic Decisions At Runtime With WebSphere Service Registry And Repository

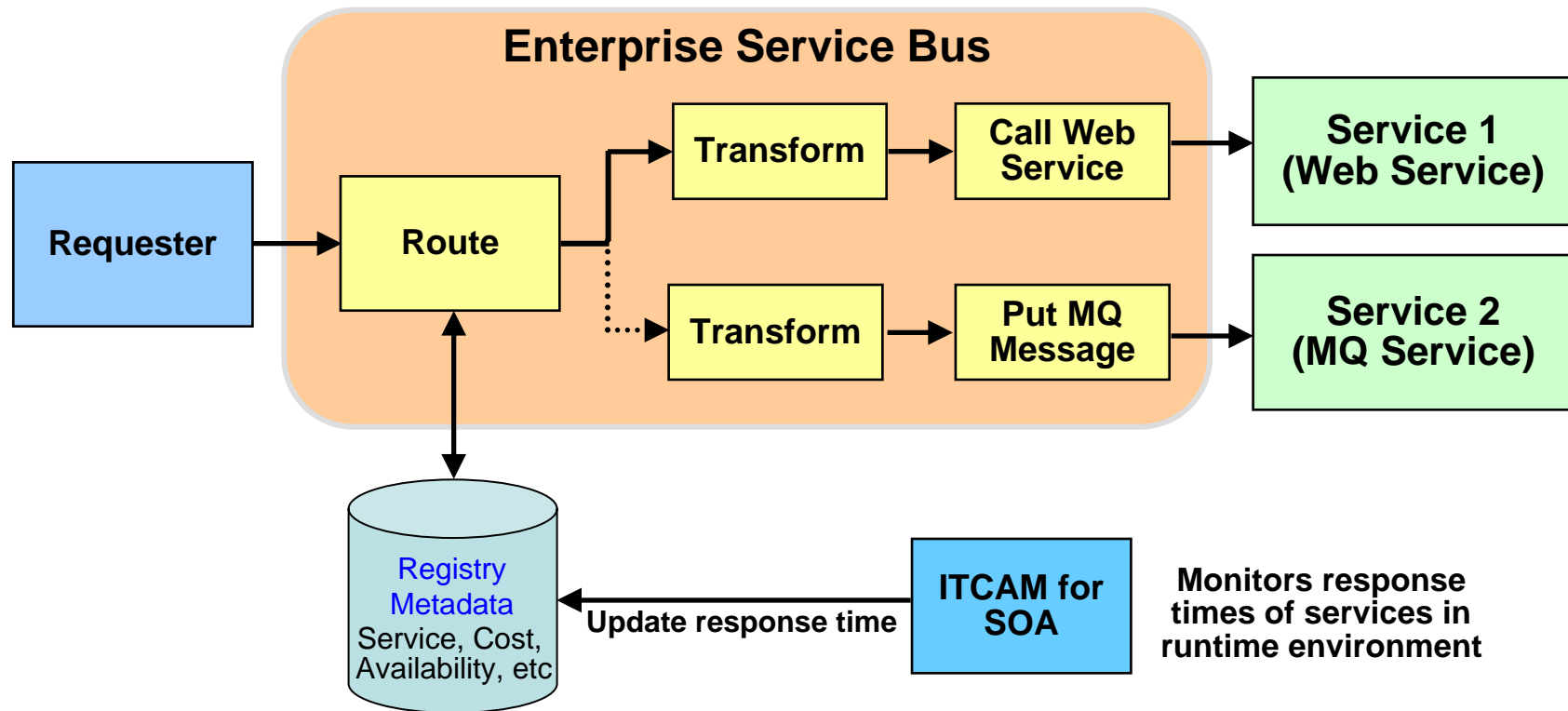

Use information about the run time environment to make dynamic routing decisions



Correlate Banking Events To Detect Potential Fraud

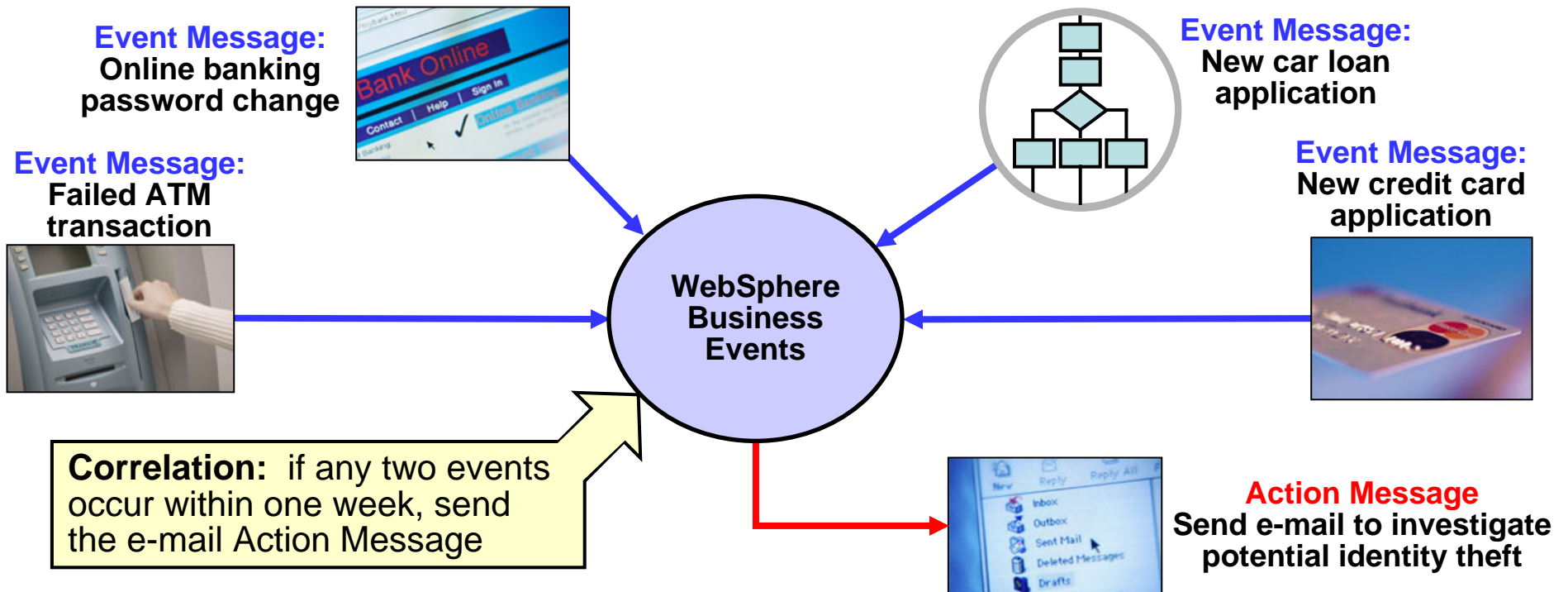

- **Business events** are discovered and described in **business terms**
 - ▶ Event recognition patterns can be specified by a **business analyst**, using included codeless, graphical authoring tools with straightforward expression of business event interaction logic
 - ▶ Delivers simple and integrated **dashboard visualization** of results

Oracle Events are IT-focused,
not for business user



Why Deploy This Process On System z?

- A Smart SOA implementation requires high quality of service from the deployment platform
 - ▶ Workload Management to handle peak demand
 - ▶ Scalability and Clustering
 - ▶ Continuous Availability/Disaster Recovery
 - ▶ Rock-solid Security
- Running on the same server provides performance advantages
- Lowest cost!



IBM Smart SOA Software Runs On System z

- WebSphere Process Server
- WebSphere Enterprise Service Bus
- WebSphere Application Server
- WebSphere Service Registry and Repository
- WebSphere Business Events
- WebSphere Business Services Fabric
- WebSphere Business Modeler Publishing Server
- WebSphere Business Monitor
- ILOG jRules



Co-location Performance Advantages

- Mainframes already house the core DB2, CICS and IMS applications and data for the business
 - ▶ Quickly expose these assets as services
- Deploying WebSphere Process Server, WebSphere Portal Server, and the assets they use in close proximity provides better performance and throughput
- HiperSockets technology greatly reduces network overhead
 - ▶ Direct memory-to-memory communication avoids layers of network code for fast performance
 - ▶ Better networking security (no wires)



On-Line Banking Benchmark Demonstrates Performance Advantages Of Co-location

Separate Machines

150 tps

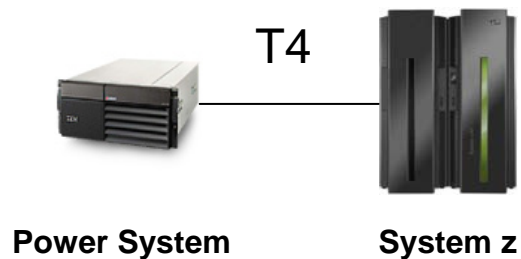
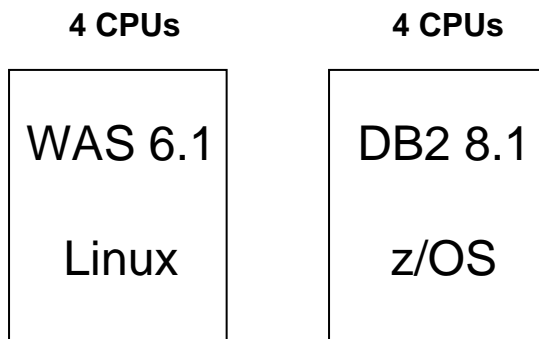

Same Platform

186 tps

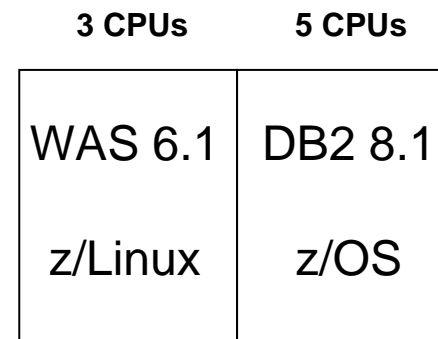

z Series Server : z9-EC, 8 X 1.7 GHz, 64 GB RAM

Deploy WebSphere Process Management Application On Mainframe vs. HP Servers

Existing Mainframe



Existing z10:
2 GP 1,720 MIPS
DB2 and utilities
With 20TB storage

Existing Disaster Recovery Site



Existing:
1 GP processor for hot
disaster switch-over
1 "dark" DR processor
With 20TB storage

Add LPAR for New Web Application w 1.28TB storage

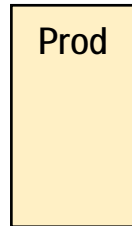

1,624 MIPS
additional
workload

Incremental:
1 zAAP 920 MIPS WPS & Portal (85%)
1 GP 541 MIPS DB2 & QMF
163 MIPS WPS & Portal (15%)
2 GB memory

And Add Disaster Recovery w 1.28TB storage

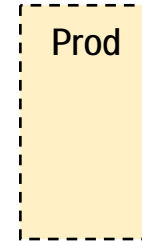

3 year
cost of
acquisition
\$4.06M

Capacity Backup:
1 GP
1 zAAP

Or Add HP Integrity Superdome 9140 Server w 1.67TB storage

Prod

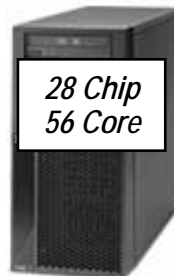

201,977*

Performance Units

And Add Disaster Recovery w 1.67 TB storage

Prod

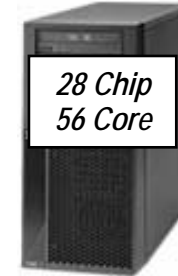

201,977*

Performance Units

3 year
cost of
acquisition
\$14.36M

*Production Performance Units required = 1,624 x 122 = 198,128

WebSphere Process Management Incremental Cost Breakdown

Mainframe Incremental Hardware

OTC		ANNUAL	
GP	\$1,358,000	Processor Maintenance *	\$90,142
zAAP	\$125,000	(For year 2, 3)	
DR Processors	\$27,000	Storage Maintenance	\$5,272
Memory (2 GB)	\$4,500	(For year 2, 3)	
IBM Storage (1.28TBx2)	\$141,750		
TOTAL	\$1,656,250	TOTAL	\$95,414 (year 2, 3)

Mainframe Incremental Software

OTC		ANNUAL	
DB2 Utilities	\$346,565	Utilities S&S	\$49,931
WebSphere Process Server	\$403,030	Process Server S&S	100,860
		Portal Enable S&S	\$48,380
		DB2 MLCx12	\$107,088
WebSphere Portal Enable	\$241,900	z/OS MLCx12	\$52,296
		QMF MLCx12	\$47,724
TOTAL	\$991,495	TOTAL	\$406,279

Distributed Incremental Hardware

OTC		ANNUAL	
HP Integrity Superdome 9140 Server	\$2,682,242	Server Maintenance	\$309,948
		(Prepaid in year 1 for 3 years)	
HP storage (1.67TBx2)	\$749,805	Storage Maintenance	\$44,400
TOTAL	\$3,432,047	TOTAL	\$974,244 (year 1) \$44,400 (year 2,3)

Distributed Incremental Software

OTC		ANNUAL	
Oracle EE & Utils	\$1,168,500	Oracle S&S	\$257,070
Oracle BPEL Process Server	\$2,220,000	Oracle BPEL Process Server S&S	\$488,400
Weblogic Portal	\$2,220,000	Weblogic Portal S&S	\$488,400
Unix	\$265,440	Unix S&S (prepaid in year 1 for 3 years)	\$96,843
TOTAL	\$5,873,940	TOTAL	\$1,524,398 (year 1) \$1,233,870 (year 2, 3)

* Mainframe Processor Maintenance includes the maintenance for general purpose processors and specialty engines

