



IBM Software Group

## With CICS TS V3.1

**Extend IBM CICS applications through a service oriented architecture to capture new audiences and opportunities**



business on demand software

This presentation explains how the CICS Transaction Server for z/OS V3.1 further enhances the functions and value of the world's most popular transaction monitor

CICS Transaction Server is an advanced solution, based on the transaction, the fundamental unit of business. So it easily adapts to the way that your business works.

The realities that many businesses face today include:

- Supporting large numbers of active users, with good performance on volatile data
- Making use of multiple sources of data, with good security and transactional integrity
- Running applications across the network with access to data on the host
- Growing the systems to cope with increasing demand while leveraging existing investments

These are just the qualities that CICS Transaction Server brings to your business. It shares your values, and matches your needs.

After all, more than 490 of the Fortune 500 companies use CICS Transaction Server, along with tens of thousands of others.

Chances are your business is one of them.

## What's on the Minds of 450 of the World's Leading CEOs

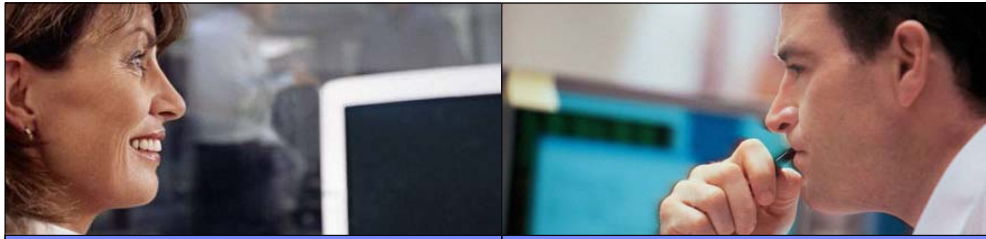

### CEO needs

- **Revenue growth** with cost containment
- Key competency: **responsiveness**
- Critical success factor: enable **effectiveness of people**

Source: CEO Study of 456 WW CEOs IBM Corporation - Feb 2004

### CIO challenges

- Aligning IT and business goals to **grow revenue and contain costs**
- Building **responsiveness** and **agility** into the organization through IT
- How can IT help **enable people and teams to be more effective**

Source: Operating Environment Market Drivers Study, IBM Corp. 2004

**Common focus on flexibility and simplification**

IBM Confidential until November 30, 2004

### Major Points:

IBM has done primary research to understand the needs of our customers...

#### CEO Needs:

IBM conducted a survey earlier this year to find out what was on the minds of CEOs. The study — the first of its kind ever done by IBM — was conducted by BCS's Strategy & Change practice and Institute for Business Value, together with The Economist and Nikkei Research.

It's official: Growth is back! over 450 CEOs participated. The study revealed that growth is a top concern among CEOs; it also found the people are a top priority, they feel that their organizations are too rigid; that China is a key market, and that they need to accomplish the 'transformation' to achieve this in the next 5 years.

#### CIO's Challenge:

This information was culled from the OE Market Drivers study. The data supports the challenges that CIOs are trying to address daily

#### Segue:

The rest of the presentation will tie back to these recurring themes (CEO needs).

## Delivering on an On-Demand Environment

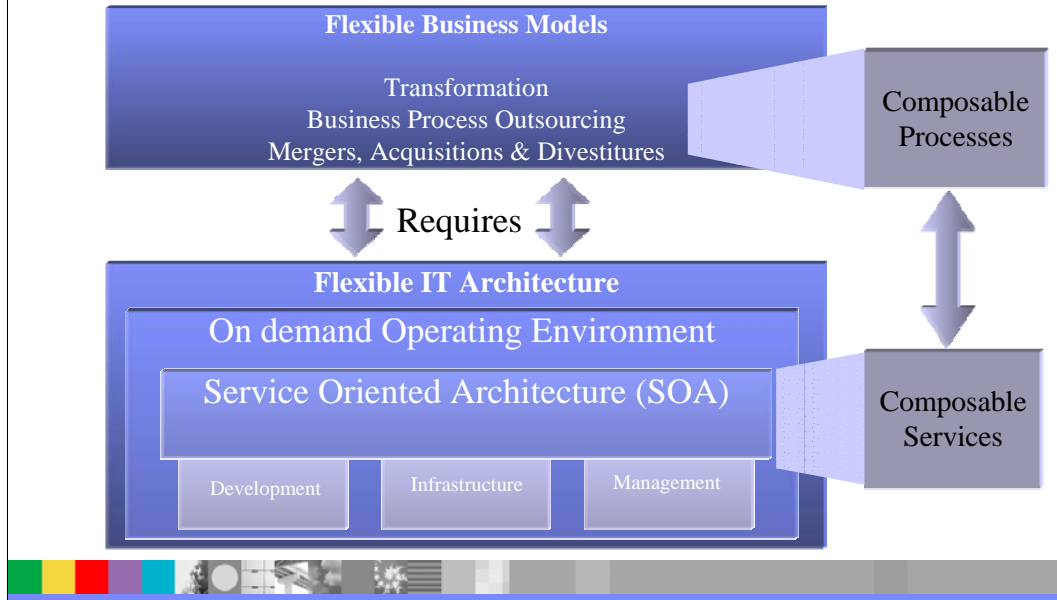

One of IBM's responses to these customer needs is the On Demand strategy. This means building flexible business models that can deliver composable processes that react to business pressures such as mergers, acquisitions and divestitures.

Customers are looking for an open, reliable, low-overhead business to business (B2B) connectivity over the Web, with flexibility being the overriding characteristic of success. Applications will be based on composition of services discovered and connected to as needed. Service integration becomes the innovation of the next generation, as businesses move more of their existing applications to the Web, taking advantage of e-portals and e-marketplaces and leveraging new technologies such as XML.

This will enable them to build business processes that are integrated across the company and with partners, suppliers and their customers that enable them to build an ecosystem that can respond to any market opportunity or competitive threat.

The underlying requirement is that we need to build a flexible IT architecture that can deliver composable services to meet these needs. This is done via a service oriented Architecture.

The building blocks for this flexible IT infrastructure are development, integration and management.

## Delivering on an On-Demand Environment

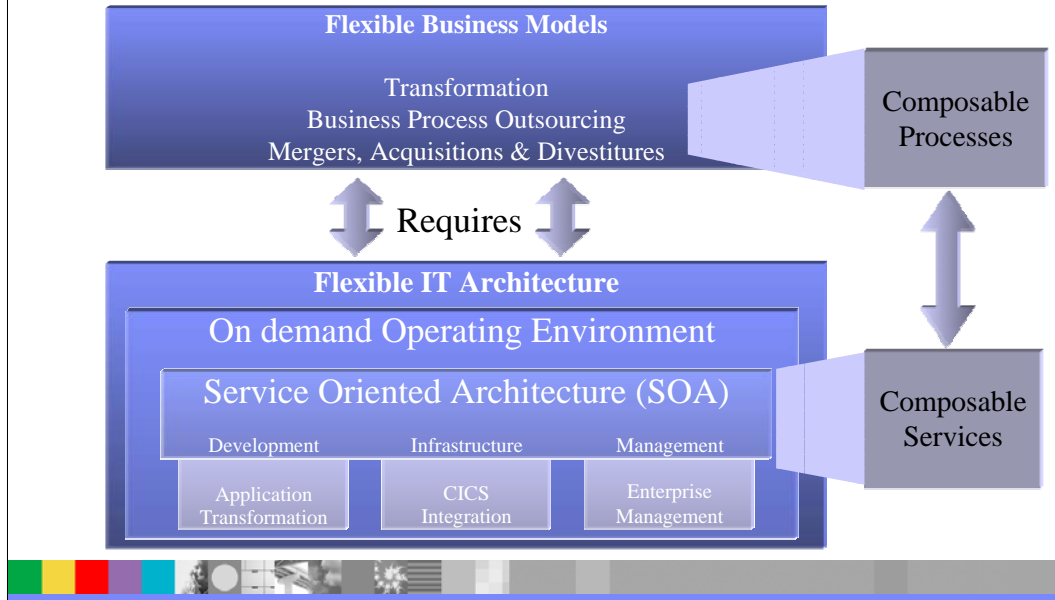

The focus of CICS TS V3.1 is to deliver a set of capabilities which provide customer value by enabling business flexibility through IT simplification. These capabilities are represented in the following themes:

- Application Transformation enables enhancement of existing applications and construction of new applications, using contemporary programming languages, constructs and tools
- CICS Integration enables re-use of CICS applications, within flexible IT infrastructure, via standard APIs and protocol
- Enterprise Management enables effective management of large runtime configurations via modern user interfaces, so that demanding service level objectives can be met.

These align with the building blocks of SOA.

## From CEOs: “Now It Is About Growing The Top Line While Keeping The Bottom Line In Check.”

Source: CEO Study of 456 Global CEOs, IBM Corporation, Feb 2004

### IT Imperatives

Support the growth agenda –  
Improve flexibility and  
responsiveness

Keep costs in check – Do  
more with less

### Driving Need to Transform Existing Applications

- Extend existing applications to new audiences and opportunities
- Exploit existing resources and skills
- Improve performance of existing workloads for faster response times and reduced costs
- Improve system management to enable management of more with less
- Simplify the development process to reduce application development costs and time to deployment



“By exploiting the next generation of integration tools, enterprises can **liberate decades' worth of legacy value.**”

InfoWorld: Tapping Into Big Iron, Eric Knorr, March 29, 2004

IBM Confidential until November 30, 2004

•Considering what customers have asked for, they are looking to redefine their applications quickly and effectively to meet their customer demands. There is a need for rapid business process adaption and reshaping. Application maintenance consuming 60-80% of IT budgets and staff turnover or retirement lessens individual programmer familiarity with existing systems, application maintenance efficiency is key driver.

•There is also a need to meet increasing development workloads. The growth in complexity of development platforms and integration needs will force organizations to turn away from code-centric development practices in exchange for more efficient development paradigms. They need better tooling to deliver more effective and efficient development processes.

•Industry adoption and proliferation of Web Services capabilities into development platforms and tools are making it easier for companies to adopt a service-based development approach. The need for richer than HTML experiences and disconnected operations will lead most companies to adopt multiple user interfaces delivery architectures

•Finally, Because of recent pressures for cost reductions and market demand for better processes, we expect continued pressure from business executives to switch to new, business-differentiating activities. There will be a continued strong drive from business for process improvements.

#### •Need for rapid business process adaptation and reshaping

- Application maintenance consuming 60-80% of IT budgets
- Staff turnover/retirement lessening individual programmer familiarity with existing systems, application maintenance efficiency is key driver
- Purging dead wood from application portfolios and streamlining and modernizing the remainder of the applications
- CIO's looking to mine for resources, funding and credibility
- CIO's who can quantify and align IT spending to business unit see significant change in role from techno spender to guiding senior executives on how to spend dollars wisely

#### •Need to meet increasing development workloads

- The growth in complexity of development platforms and integration needs will force organizations to turn away from code-centric development practices in exchange for more efficient development paradigms
- Industry adoption and proliferation of Web Services capabilities into development platforms and tools are making it easier for companies to adopt a service-based development approach
- The need for richer than HTML experiences and disconnected operations will lead most companies to adopt multiple user interfaces delivery architectures

#### •Continued pressures for cost reductions and market demand for better processes

- Looking for cost savings by managing business processes better
- Important consideration is the business process rather than the best architecture

## Announcing CICS Updates To Enhance Ease of Integration and Performance

### CICS Transaction Server V3.1

#### Increased ease of integration

- Web Services capabilities to extend CICS applications to a Services Oriented Architecture
- Support for industry-leading SSL protocol

#### Enhanced application transformation

- Ability to leverage single development tool for application transformation and integration
- Optimized CICS data exchange capabilities

#### Improved performance & system management

- Extension of CICSplex SM Web User Interface
- Improved workload throughput
- Enhanced C/C++ programs performance

IBM Confidential until November 30, 2004

•CICS Transaction Server V3.1 provides capabilities to enable CICS-based applications to be integrated with a Service Oriented Architecture (SOA), enabling them to be exposed as Web Services. CICS has the ability to act as a Web Services service provider and service requestor which means it can be seen as a full participant in this B2B world.

•With this enhancement CICS is protecting investments in applications and removing the need for customers to do unproductive redesign and recoding of applications. Support in this area of the CICS product demonstrates our continuing support for traditional CICS application development. It provides enhanced performance and reduced costs for these workloads

•The CICSplex System Manager is an integral part of CICS TS. Its role is to reduce the complexity of management of CICS systems by presenting them as a simple and integrated whole. It integrates all the major CICS management functions into one interface. It cooperates with Tivoli products to meet the need to integrate management and automation of CICS with z/OS and the network. This release continues the strategic themes for systems management of integration, simplification, monitoring and automation.

## CICS Integration: Web Services

- **Provides capabilities to enable CICS-based applications to be exposed as Web Services.**
  - Both a Web Services service provider and service requestor
  - Full participant in this B2B world.
- **Enables new interoperability between these applications.**
- **Provides standards-based interfaces to software functionality.**
  - Consumers need have no knowledge beforehand about a Service
  - Software developers to focus on the business issues not the architecture.
- **Simple transformation through the CICS Web Services Assistant.**
  - Provided for COBOL, C/C++ and PL/I
  - Enables leverage of traditional programs in new business processes
- **Major advance over the SOAP for CICS feature delivered on CICS TS V2**
  - Workload distribution & Resource management
- **Sample application is provided**
  - Illustrates how to code and implement a Web Service application
  - Ensures a customer business can receive immediate value

Considering the content of CICS TS V3.1 we start with the integration theme

CICS Transaction Server V3.1 provides capabilities to enable CICS-based applications to be integrated with a Service Oriented Architecture (SOA), enabling them to be exposed as Web Services. CICS has the ability to act as a Web Services service provider and service requestor which means it can be seen as a full participant in this B2B world.

By allowing CICS applications to be wrapped in this way and exposed as services, it easily enables new interoperability between these applications. This provides services to enable virtual enterprises to link heterogeneous systems as required. Examples include mergers, where the resulting enterprise must integrate disparate IT systems and business processes, or the combination of the travel industry and pervasive computing, when a travel application can be exposed as a service and made available for use by various devices in a service-oriented environment.

Web Services provide standards-based interfaces to software functionality. Each Web Service describes how other systems, known as Web Service consumers, can connect to it and exchange information with it. Therefore, the consumers need have no knowledge beforehand about a Service, other than where to find it and that it is based on the common Web Services standards. This approach enables software developers to focus on the business issues not the architecture.

To ensure it is relatively simple to transform an existing CICS application into a Web Service, there is a application development capability supplied called CICS Web Services Assistant. This support is provided for COBOL, C/C++ and PL/I thus ensuring traditional program languages are able to participate and deliver immediate value to your existing application set. Given the existing investment customers have made in CICS business transactions, this ability to easily leverage them in new business processes is of huge value to the customer.

These capabilities should be seen as a major advance over the SOAP for CICS feature delivered on CICS TS V2. With the provision of workload distribution and resource management facilities for this new workload, it ensures it receives the qualities of service expected for a CICS function.

To help with best practice, a new sample application is provided which illustrates how to code and implement a Web Service application. This ensures a customer business can receive immediate value from this ability.

## Web Services Helps Charles Schwab Respond to Market Conditions and Customer Needs

### Business Challenge

Capture a new market opportunity by offering independent consultation and advice on a fee basis, leveraging existing IT assets

### Solution

Partnered with IBM to build a services oriented architecture

### Benefits

Shortened time to market for new service, minimized impact to existing applications and enabled them to leveraged their existing IT investment and skills



***“We need IBM to enable CICS as a service provider and eventually as a consumer and look forward to the day when CICS is fully Web Services enabled.”***

– Charles Schwab team

IBM Confidential until November 30, 2004

Now we can see the first of a couple of examples of how we've been working with customers and the benefits they've been getting from our existing SOAP for CICS feature, and the first one is with Charles Schwab who have really been involved with us from very early stages in this exercise and they're being very aggressive in their move to WSDL description of services and SOAP over HTTP and SOAP of MQ at the backbone of their infrastructure. And they're just starting to explore the other scenarios of CICS Applications as Web Service clients because they realise that once they get a uniform description of the services through WSDL then hosting these services on CICS or on WebSphere and indeed having dot net clients will give them lots of advantages in the flexibility of their IT infrastructure so they are a very good customer for us to reference because of their maturity in this solution. But going onto the next chart Slide 9...



## Web Services Provides Santa Clara County (SCC) Criminal Justice Information System a Face Lift

### Business Challenge

Provide an easy-to-use, secure, industry-standard way for customers to access Criminal Justice Information Control System (CJIC) data.

### Solution

Evolve existing CICS-based transaction services to be web services and allow them to be accessed using SOAP. The new SOAP for CICS feature is being used as the "middleware" to SOAP enable the transactions to enable deployment on CJIC's z/OS system



### Benefits

New transaction services are managed by SCC's existing S/390 skilled staff and its users now have a fast, reliable system from which to access the information they need

IBM Confidential until November 30, 2004

The Criminal Justice Information Control System (CJIC) is Santa Clara County's criminal case history and tracking system.

We are seeing a breadth of customer types that are moving towards this style of solution so here we have the example of the Santa Clara Criminal Justice System and you can probably expect that they haven't quite got the same level of infrastructure skills as Charles Schwab do but as part of our reference building program we do know that they've been able to take the feature, deploy it and really get some business value from it.

## Application Transformation: Inter-program Data Transfer

- **CICS TS V3.1 provides improved method of exchanging data**
  - overcomes inherent customer problems
- **Not limited in size to 32KB.**
  - limited only by the amount of storage available.
- **Pass data in a more structured way.**
  - Reduces the complexity of designing programs
  - Reduces the amount of transaction storage needed
  - Delivers an acceptable deployment environment for C++ and Java programs
- **Any of the CICS supported languages, including Java**

Now lets consider the Application Transformation theme

Traditionally, CICS programs have used communications areas (COMMAREAs) to exchange data. In order to overcome inherent problems raised by customers over many years an improved method of exchanging data is being provided in CICS TS V3.1.

This enhancement introduces two new concepts. Containers and Channels. You can think of Containers as named COMMAREAs. They can be grouped together in sets called Channels which is analogous to a parameter list.

The channel/container model has several advantages over COMMAREAs:

Unlike COMMAREAs, Channels are not limited in size to 32KB. There is no limit to the number of containers that can be added to a channel and the size of individual containers is limited only by the amount of storage available.

Because a channel is comprised of multiple containers, it can be used to pass data in a more structured way. In contrast, a COMMAREA is monolithic block of data.

Unlike COMMAREAs, channels don't require the programs that use them to know the exact size of data returned

Channels can be used by CICS application programs written in any of the CICS supported languages. For example, a Java client program on one CICS regions can use a channel to exchange data with a COBOL server program on a back-end AOR.

The ability to use multiple containers reduces the complexity of designing programs, because the programs would not have to reformat data into a single commarea as has to happen today. Multiple containers would also allow greater independence when maintaining programs. With one large commarea used by utility programs, every program that calls the utility must be re-compiled when data elements are added to the commarea. If multiple containers are used, only programs affected by the addition of data elements would need to be re-compiled. Multiple containers would also reduce the amount of transaction storage needed, because an extra area is needed to reformat multiple data areas into a single commarea.

Java and C++ applications outside of OS/390 use distributed program link to larger than 32KB, reducing the transmission time of data ( only 1 program link ), simplifying program logic, eliminating the need for segmenting techniques. By removing this restriction, it helps view CICS as an acceptable deployment environment for C++ and Java programs and reduces the programming effort needed.

## New in CICS Transaction Server V3.1 – Improved Performance and System Management

- **Businesses have moved from single-processor servers to Symmetric Multiprocessor (SMP) servers**
  - single-system image cluster
  - shared data
  - Workload balancing can ensure an even distribution of work.
- **Open Transaction Environment exploits this technology.**
  - CICS TS 2.2 we added support that enabled CICS/DB2 applications
    - Improved performance for these applications.
  - CICS TS V3.1 introduced the ability for all types of applications
    - Removed a major bottle neck in the application throughput running under CICS.
  - Alternative is to divide applications between several CICS regions.
    - Tough job and supervising the new CICS regions is difficult.
  - Reduces CPU utilization
    - Reduces cost of running that application.
- **With this enhancement CICS is protecting investments in applications and removing the need for customers to do unproductive redesign and recoding of applications.**

© 2004 IBM Corporation

In their attempts to create Enterprise Computing systems, businesses have moved from single-processor servers to Symmetric Multiprocessor (SMP) servers and more recently, to multiple SMPs. Now more and more companies are taking the next step and clustering these servers.

A cluster consists of interconnected SMPs utilized as a single, unified computing resource. The most effective form of clustering is the single-system image cluster, where all the servers appear to client applications as a single system. In this "shared data" approach, every server has access to all the data, and any transaction can run on any server. Workload balancing can ensure an even distribution of work.

CICS introduced the concept of Open Transaction Environment to exploit this technology. In CICS TS 2.2 we added support that enabled CICS/DB2 applications to run in an OTE which delivered improved performance for these applications.

In CICS TS V3.1 we have introduced the ability for all types of applications to benefit, whether it is a CICS/DB2 application or not. This removed a major bottle neck in the application throughput running under CICS.

Many of our customers have been asking for this facility. An example is a customer who has a Stock Exchange System, which carries out tasks that tends to monopolize a CPU for a considerable amount of time. That leads, of course, to response time problems for all tasks in that CICS. Application tasks are waiting excessively for resources and will achieve reduced response times.

The alternative is to divide applications between several CICS regions. Dividing applications into several CICS regions is a tough job and supervising the new CICS regions is difficult. CICS region is CPU constrained and by reducing the path length of the application task will achieve CPU reduction

Reducing CPU utilization of an application will for some customers reduce cost of running that application. A major benefit for reducing total cost of ownership.

Support in this area of the CICS product demonstrates our continuing support for traditional CICS application development. It provides enhanced performance and reduced costs for these workloads

With this enhancement CICS is protecting investments in applications and removing the need for customers to do unproductive redesign and recoding of applications.

## New in CICS Transaction Server V3.1 – Improved Performance and System Management

### Enhanced C/C++ programs performance

- Allows customers to exploit features of the new C++ compiler
- Makes CICS a more attractive deployment environment for C/C++ and Java Programs

### Enhanced Open Transaction Environment (OTE)

- Delivers improved CICS workload throughput, improving transaction performance
- Enables workload balancing across the system, maximizes resource utilization
- Reduces need for cloning of CICS regions, simplifying system management

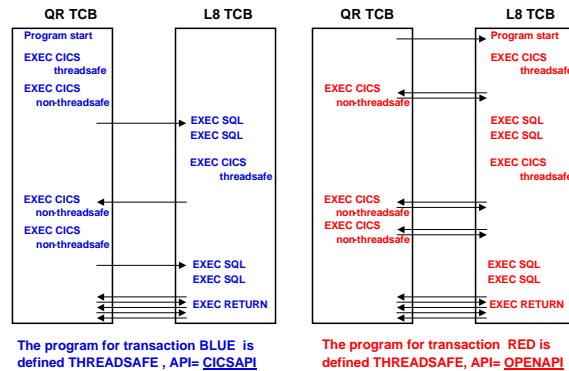

IBM Confidential until November 30, 2004

We're actually going to enhance and make available this capability in a couple of different ways. Firstly we do have a growing community of customers who are choosing C and C++ to implement their applications with. The very latest optimisations for efficient code generations in the C++ arena is a technology called XPLink which has been available for a couple of years now but up until now, not supported in a CICS environment and will offer the ability to execute XPLink C++ code using the OTE technology. We know a lot of customers are getting benefit from OTE in the DB2 arena and we will be bringing those similar advantages more widely, not least because we will be opening up OTE capability to standard COBOL PL1 and assembler programs so that they can be defined to run on independent TCBs. Now this does still require the basic notion that these applications are threadsafe. CICS Apps haven't had to be truly threadsafe whilst executing on a QR because the serialisation that's implicit there, but we are getting an increasing number of customers that are making sure their applications are threadsafe being able to run truly concurrently on the z/Series hardware.

## New in CICS Transaction Server V3.1 – Improved System Management

### Extension of the CICSplex System Manager Web User Interface (WUI)

- Reduces complexity in management of CICS systems by providing single point of control and definition
- Enables system programmer staff to manage more with less
- Provides modern browser based solution to deliver intuitive interface.
- Dramatically reduced time for system configuration

The screenshot displays the CICSplex SM Web User Interface. The main window shows an 'Active task' table with columns for Record Name, Task ID, Transaction, Dispatch status, User ID, Principal facility, VTAM LU, Task priority, and Transaction class. Below the table, a 'Resource selection' dialog is open, showing a list of resources with columns for 'Select', 'Resource name', and 'Resource description'. Callouts point to various UI elements: 'Collapsible Filters' at the top right, 'Ability to add a view to favourites' at the top right, 'Reduction in white space' pointing to the table area, 'Improved visual presentation' pointing to the table area, 'Favourite views' pointing to the left sidebar, 'User Profiles' pointing to the left sidebar, and 'Selection lists' pointing to the 'Resource selection' dialog.

IBM Confidential until November 30, 2004

The CICSplex System Manager is an integral part of CICS TS. Its role is to reduce the complexity of management of CICS systems by presenting them as a simple and integrated whole. It integrates all the major CICS management functions into one interface. It cooperates with Tivoli products to meet the need to integrate management and automation of CICS with z/OS and the network. This release continues the strategic themes for systems management of integration, simplification, monitoring and automation.

Through the CICSplex SM Web User Interface (WUI), CICS has a modern intuitive interface for all aspects of CICS system management.

The screen design has been enhanced to ensure a great improvement in usability and to meet many of the customer requirements in this area. The Business Application Scoping (BAS) administration views have been restructured to improve their usability. They have been divided into two groups: basic BAS, which emulates RDO and advanced BAS, which exploits the advanced features of CICSplex SM.

Delivers a modern user interface for managing your system management needs for CICS. It is now possible to completely configure CICSplex SM using this interface. Establishing a CICSplex SM environment in this configuration significantly reduces the time to exploitation of new functions and reduces the complexity of migration.

CICS TS V1 = days to config

V2, = half a day

V3 in an hour

Reconfig in batch

Two levels of config – basic (RDO style) and advanced

## Southern Californian Edison Improves System Management

### Business Challenge

Reduce the cost of managing IT environment

### Solution

Leveraged the CICS Web User Interface (WUI) to make network operations staff more aware of the state of our production CICS regions

### Benefits

Helped reduce the time required for Technical Support staff to monitor and administer production systems



IBM Confidential until November 30, 2004

Southern California Edison (SCE) provides electricity service to over 11.5 million people throughout a 50,000 square mile service territory in Southern California. The company's services include generation, transmission, distribution and customer service.

## Information Centre

- **A plug-in that is powered by Eclipse technology.**
  - A common framework
    - Offering a common look and feel
    - Allows users to customize their own Information Centers using plug-in from multiple products.
    - Enables direct links (eSupport) from the CICS information to support information.
- **New functions included are:**
  - A 'What's New' organized by major functional area
  - Learning Paths – a sequence of topics that help a user learn about a new area of the product.
  - Information Roadmaps – a set of comprehensive links to information from a variety of sources
- **This all means that by reducing the time to evaluate and learn new functions in CICS customers will be quicker to exploit and gain advantage from this new release.**

The Information Centre as the major source publications for the product is released as a plug-in that is powered by Eclipse technology. This brings a range of benefits to the user. A major benefit is the use of a common framework which is now the infrastructure of choice adopted by many IBM products, offering a common look and feel, together with consistency of behavior and a new search engine. It also allows users to customize their own Information Centers using plug-in from multiple products. The new Information Centre enables direct links (eSupport) from the CICS information to support information.

New functions included are:

A 'What's New' organized by major functional area

Learning Paths – a sequence of topics that help a user learn about a new area of the product.

Information Roadmaps – a set of comprehensive links to information from a variety of sources

This all means that by reducing the time to evaluate and learn new functions in CICS customers will be quicker to exploit and gain advantage from this new release.

## Key software prerequisites

- **z/OS Version 1 Release 4 (5694-A01), or later**
  
- **IBM SDK for z/OS Java 2 Technology Edition, V1.4.2**
  - For Java, Enterprise JavaBeans applications and the CICS Web Services Assistant



## CICS TS V3.1 packaging



- **CICS TS V3.1 product elements**

- CICS MVS/ESA
- CICSplex System Manager
- Information Center
- REXX Development and runtime for CICS/ESA
- Tivoli Global Enterprise Manager CICSplex SM Instrumentation
- CICS Application Migration Aid

- **WebSphere Studio Enterprise Developer V5.1 (WSED)**

- Integrated development environment for CICS and WebSphere
  - COBOL, PL/I, Java and J2EE development
  - z/OS file system integration
- 1 x unrestricted entitlement

# WebSphere Studio Enterprise Developer (WSED)

## What is WSED?

Brings the power of modern application architectures and rapid application development and robust team support, to diverse enterprise IT organizations

- Intuitive, visual construction based on open standards (JSF and Struts)
- Broad SOA support through Web Services and JCA linking visual environments and user sessions to CICS QOS
- Easy to learn, COBOL like language for rapid UI and Business dev.
- Facilities to develop, debug and deploy Java, COBOL, & PL/I applications and services



## Statement of Direction - What's Coming

CICS V3 exploitation - Subsystem support latest – CICS, WAS, DB2

- **Connectivity enhancements**
  - WSDL automation from existing processing
  - Support for new CICS WS run timemarshallers
  - XML based COBOL adapter enhancements
  - JCA connectors supporting latest CTG
- **Modern Architectural enhancements**
  - Service Flow Modeler support (Preview)
  - Leverages support for channels
- **Traditional support for:**
  - EGL support for VG based Web Transactions
  - BMS Editor
- **Integration with other IBM application lifecycle products**
- **Eclipse V3 exploitation**

## WSED Benefits

Single tool for all application transformation

- Increase developer productivity
- Leverage existing processing by enabling legacy assets to be used in SOA's
- Integrate with lifecycle
- Extend skill sets across the organization
  - Enterprise Generation Language limits need for Java or traditional expertise

## Comprehensive set of CICS focused tools

- **CICS Subsystem Management Tools**
  - CICS Performance Analyzer for z/OS V1.3
  - CICS Performance Monitor for z/OS V1.2
  - IBM Session Manager for z/OS V1.1
  - CICS Online Transmission Time Optimizer for z/OS V1.1
  - CICS VSAM Recovery for z/OS V3.3
  - CICS VSAM Copy for z/OS V1.1
  - CICS Batch Application Control for z/OS V1.1
- **Application Development tools**
  - IBM Application Monitor for z/OS V2
  - IBM Fault Analyzer for z/OS V5.1
  - IBM Debug Tool for z/OS V5.1
  - IBM WebSphere Studio Enterprise Developer V5.1.2
- **CICS Application Transformation Tools**
  - CICS Interdependency Analyzer for z/OS V1.3
  - CICS Business Event Publisher for MQSeries V1.2
  - CICS VSAM Transparency for z/OS V1.1
- **Connector technologies**
  - CICS Transaction Gateway V6.0
  - MQSeries Integrator Agent for CICS Transaction Server

## Summary - CICS Transaction Server V3.1

- **CICS is IBM's premier transaction processor for the z/OS that provides:**
  - An efficient and optimized runtime for the extension and reuse of existing CICS applications
  - Services to easily develop applications that exploit new technologies by building on CICS skills
  - First class management and support of mixed application types and workloads
- **CICS TS V3.1 will be available 25 March 2005**

### *Increased ease of CICS Integration*

- **Web Services capabilities to extend CICS applications to a Services Oriented Architecture**
- **Support for industry-leading SSL and TLS protocols**

### *Enhanced Application transformation*

- **Ability to leverage single development tool for application transformation and integration**
- **Optimized CICS data exchange capabilities**

### *Improved performance & Enterprise Management*

- **Extension of CICSplex SM Web User Interface**
- **Improved workload throughput**
- **Enhanced C/C++ programs performance**

## For more information

- **IBM CICS Transaction Server for z/OS V3.1**
  - IBM Software Announcement 204-285 and the *Transaction Servers & Tools e-newsletter*  
[ibm.com/cics](http://ibm.com/cics)
  - Release Guide, Migration Guide, technical papers, manuals  
[ibm.com/cics/library/](http://ibm.com/cics/library/)
- **IBM CICS Tools**  
[ibm.com/cics/tools](http://ibm.com/cics/tools)
- **IBM Websphere Studio Enterprise Developer**  
[ibm.com/software/awdtools/studioenterprisedev/](http://ibm.com/software/awdtools/studioenterprisedev/)
- **IBM SDK for z/OS, Java 2 Technology Edition V1.4**  
[ibm.com/servers/eserver/zseries/software/java](http://ibm.com/servers/eserver/zseries/software/java)
- **IBM z/OS**  
[ibm.com/servers/eserver/zseries/zos](http://ibm.com/servers/eserver/zseries/zos)

## Acknowledgements

- **The following are trademarks of International Business Machines Corporation in the United States, other countries, or both: IBM, CICS, CICS/ESA, CICS TS, CICS Transaction Server, DB2, MQSeries, OS/390, S/390, WebSphere, z/OS, zSeries, Parallel Sysplex.**
- **Java, and all Java-based trademarks and logos, are trademarks of Sun Microsystems, Inc. in the United States, other countries, or both.**
- **Microsoft, Windows, Windows NT, and the Windows logo are trademarks of Microsoft Corporation in the United States, other countries, or both.**
- **Other company, product, and service names and logos may be trademarks or service marks of others.**