

Smart Work 그리고 Workplace Innovation

김옥 사업부장

IBM Korea Lotus 사업부 총괄

2009년 9월 2일



목차

- Smart Planet 그리고 Smart Work
- Workplace 혁신의 필요성 - 기업 환경 및 업무 형태가 변화하고 있다
- Workplace 혁신이란
- Workplace 혁신의 효과
- Smart Work을 위한 Lotus의 전략



Our world is changing

2 Billion

people will be on the web by 2011.*



4 Billion

mobile phone subscribers worldwide by the end of 2008.*



1 Trillion

connected intelligent devices in the world



\$650 Billion

in productivity is lost because of unnecessary business process interruptions



85%

of computing capacity sites idle



*Sam Palmisano speech, November 12, 2008



A Smart Planet – The Next Leadership Agenda



NEW INTELLIGENCE

Data exploding and in silos
I need insight.



GREEN AND BEYOND

Limited resources
I need efficiency.



SMART WORK



New business and process demands
I need to work smart.



DYNAMIC INFRASTRUCTURE

Costly and inflexible infrastructure
I need to respond faster.



CEO의 생각

Business Model Innovation is important as part of the innovation mix

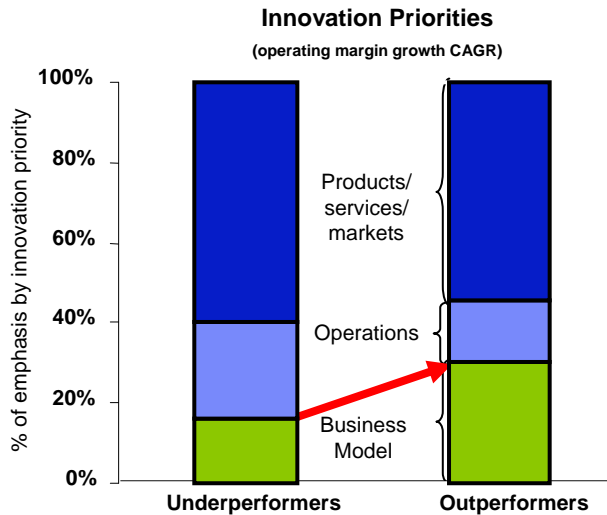

Collaboration is indispensable – but the gap between importance and practice is large

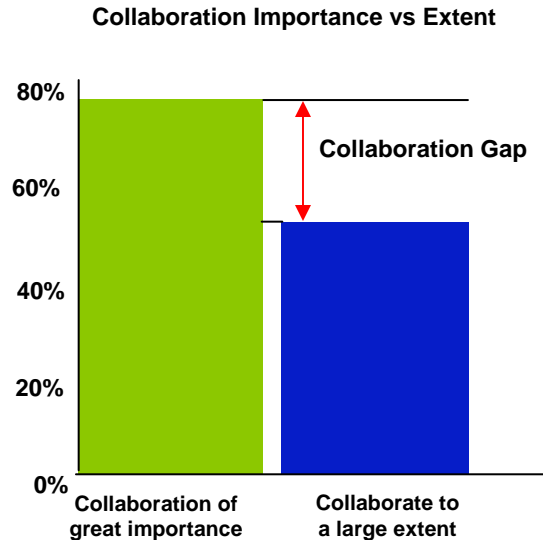

Business & technology integration is key – but few do it successfully

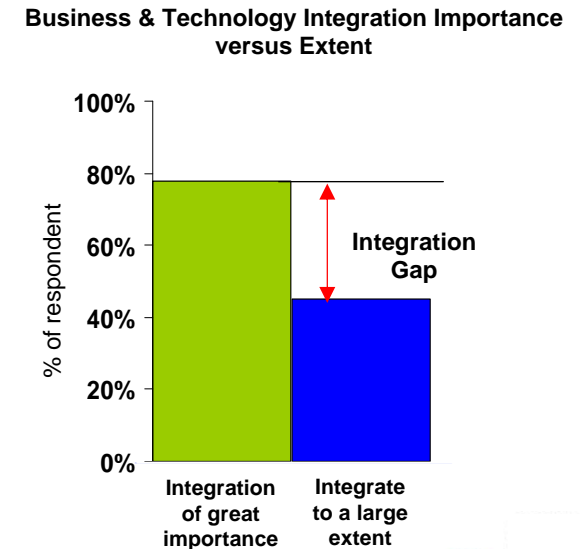

Source: IBM, The Global CEO Study: Expanding The Innovation Horizon, 2006



CEO의 생각

External Forces Impacting the Organization

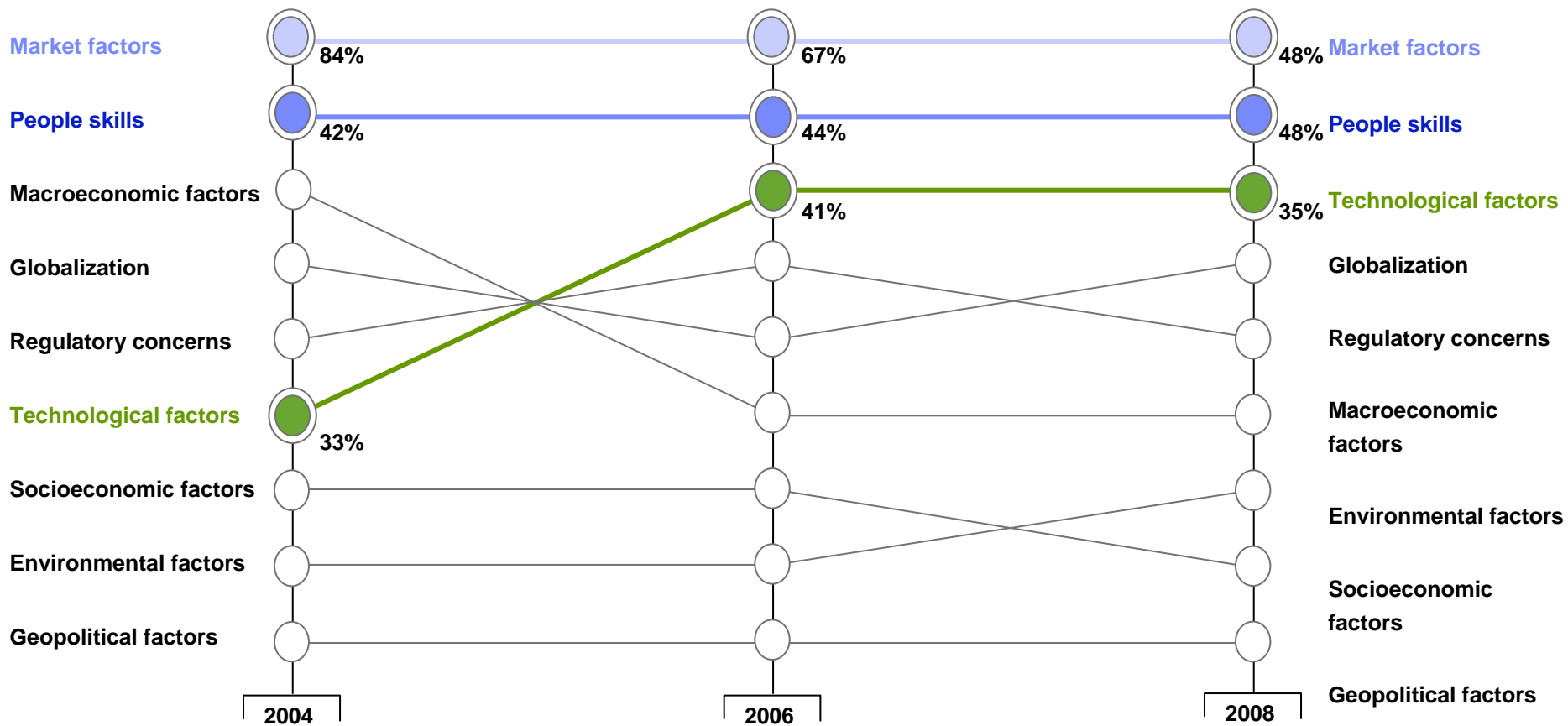

Source: IBM Global CEO Study 2008; n (2004) = 403, n (2006) = 760, n (2008) = 1130



기업환경의 변화 - IT역할의 증가

IT임원의 최우선과제

□ 기업의 성장 전략과의 연계와 지원은 IT 최우선 과제 임

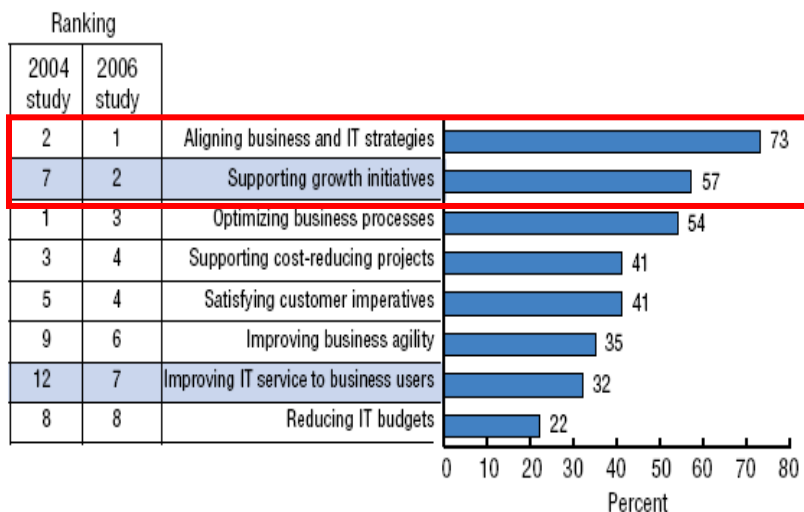

Source: IBM Global Business Services, 2006 GMA Information Technology Investment and Effectiveness Study; CSC, 2004 GMA Information Technology Investment and Effectiveness Study.
 Note: The sum of all percentages exceeds 100 percent because respondents were asked to select their top five priorities.

IT 역할의 증가

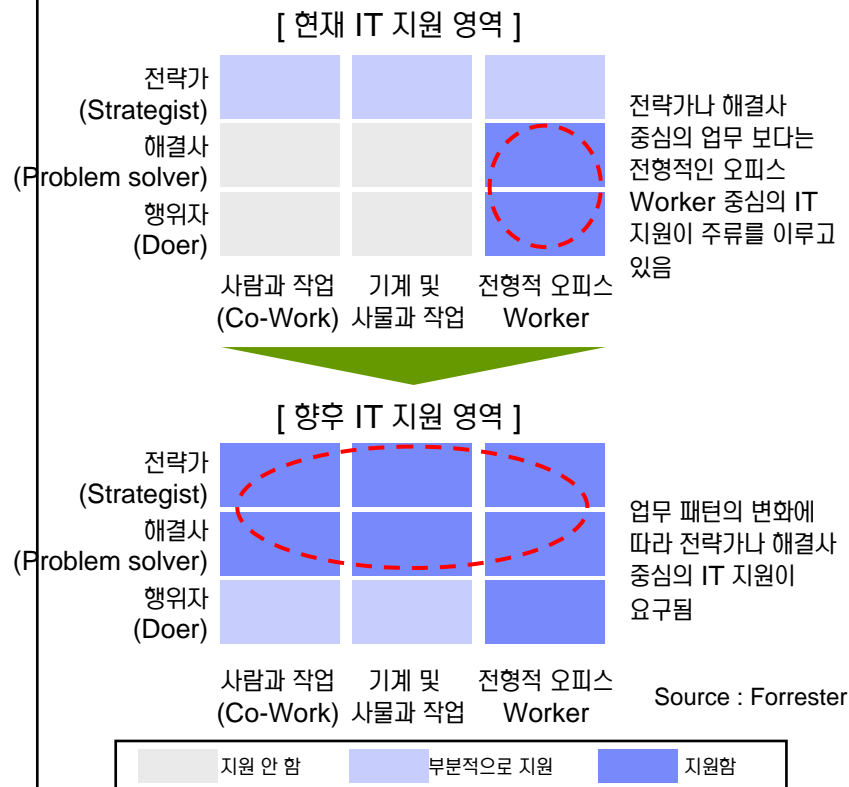

기업환경의 변화 - 창의적인 업무 (Non-Routine Cognitive)의 증가

업무 패턴의 변화

□ 일상적이고 정형화된 업무는 ERP, CRM, SCM 등 IT 지원을 통하여 자동화되거나 감소함

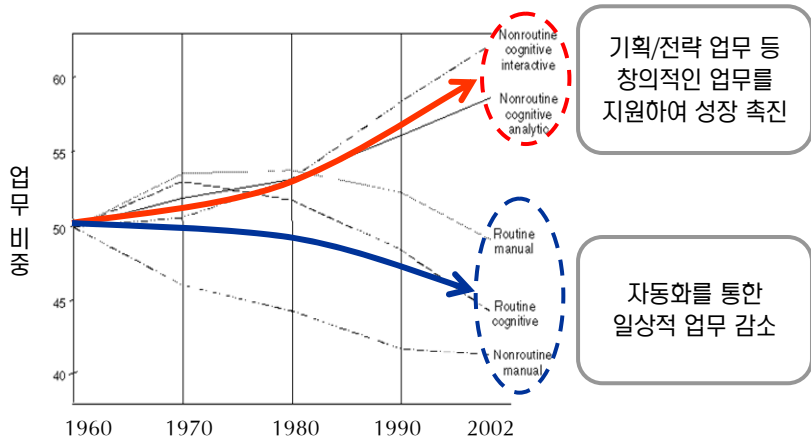

* Source: Gartner, New Knowledge Worker Demands Will Challenge IT Practitioners

증가하는 기획적 / 전략적 업무는 공동 작업 등을 통하여 많은 분석과 판단이 필요하며 이를 지원하는 인프라가 요구됨

업무 형태(협업)의 추세

□ 향후의 업무 형태는 다른 시간 또는 다른 장소에서 이루어지는 비중이 증가

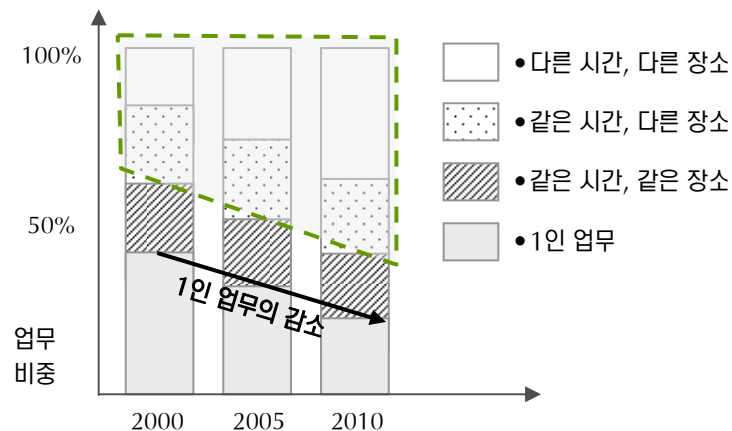

* Source: Gartner (March, 2006)

업무 분담, 연계 작업의 비중 증가로 시·공간적 제약을 극복하며 구성원간 협업을 지원하는 업무 환경 필요함

Research가 바라본 Workplace

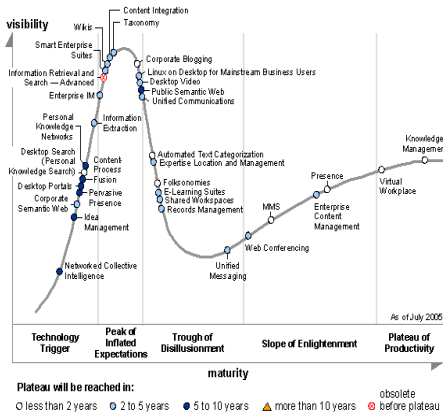

On demand Workplace



“언제 어디서나 정보와 어플리케이션, 협업시스템에 접근할 수 있는 역할기반의 유기적인 환경.”

High-Performance Workplace



“구성원과 Process, 물리적인 환경과 IT기술에 지속적/ 균형적으로 투자함으로써 이루어진다.”

Information Workplace



“포탈, 협업기술, BPM, 콘텐츠 관리 등을 통해 지식근로자에게 다양한 콘텐츠를 다양한 환경에서 제공하는 소프트웨어 플랫폼이다.”

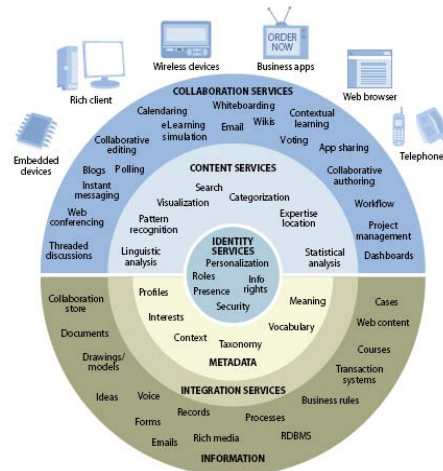

Enterprise Workplace



“사람, 프로세스, 정보의 연계를 지원하는 인프라이며, 교류환경이다.”

Workplace Innovation

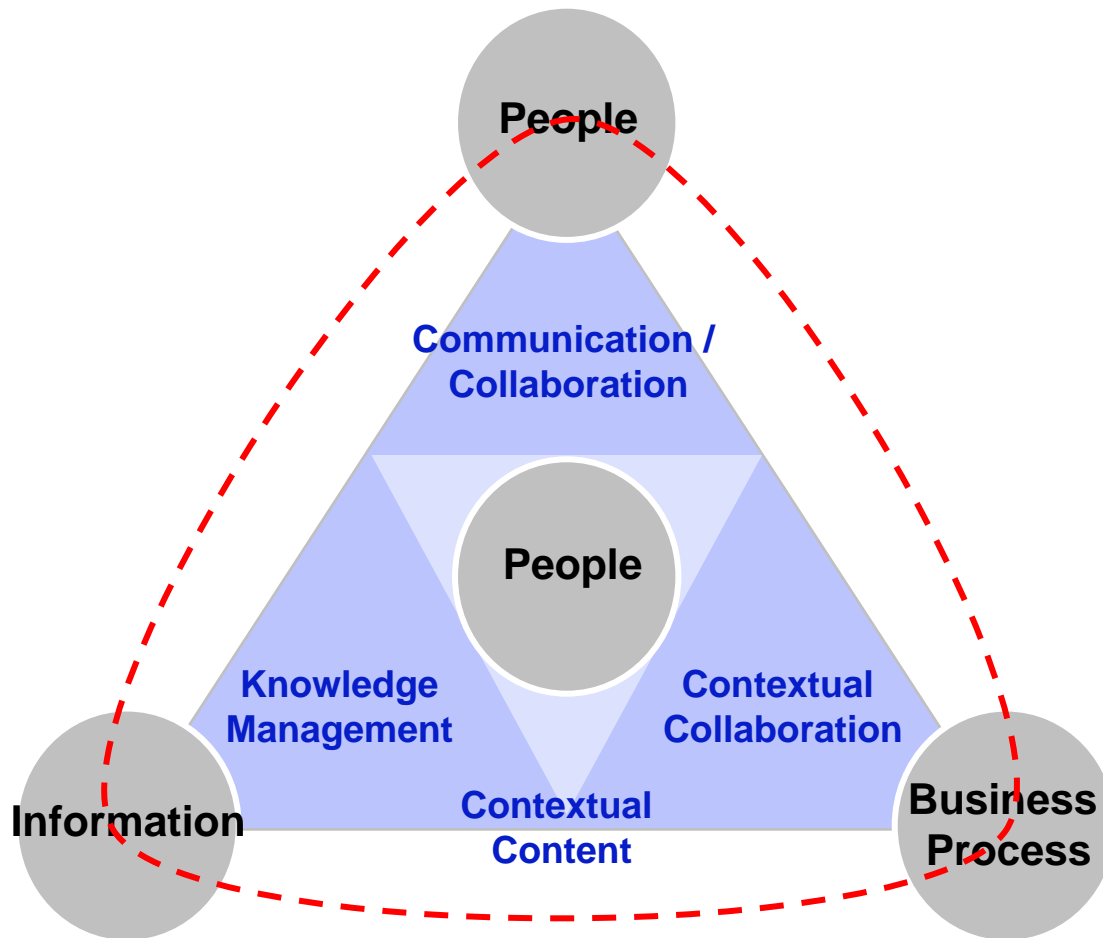

업무환경의 근본적인 변화: 특성과 개념

- **People - People:**
구성원과 구성원의 커뮤니케이션과 협업을 지원
- **People - Information:**
구성원의 지식을 공유하고 검색
- **People - Business Process:**
Application 중심이 아닌 구성원의 업무에 따라 그 환경을 지원
- **People - Information - Business Process:**
Context (업무환경) 에 맞는 정보의 제공

Workplace Innovation

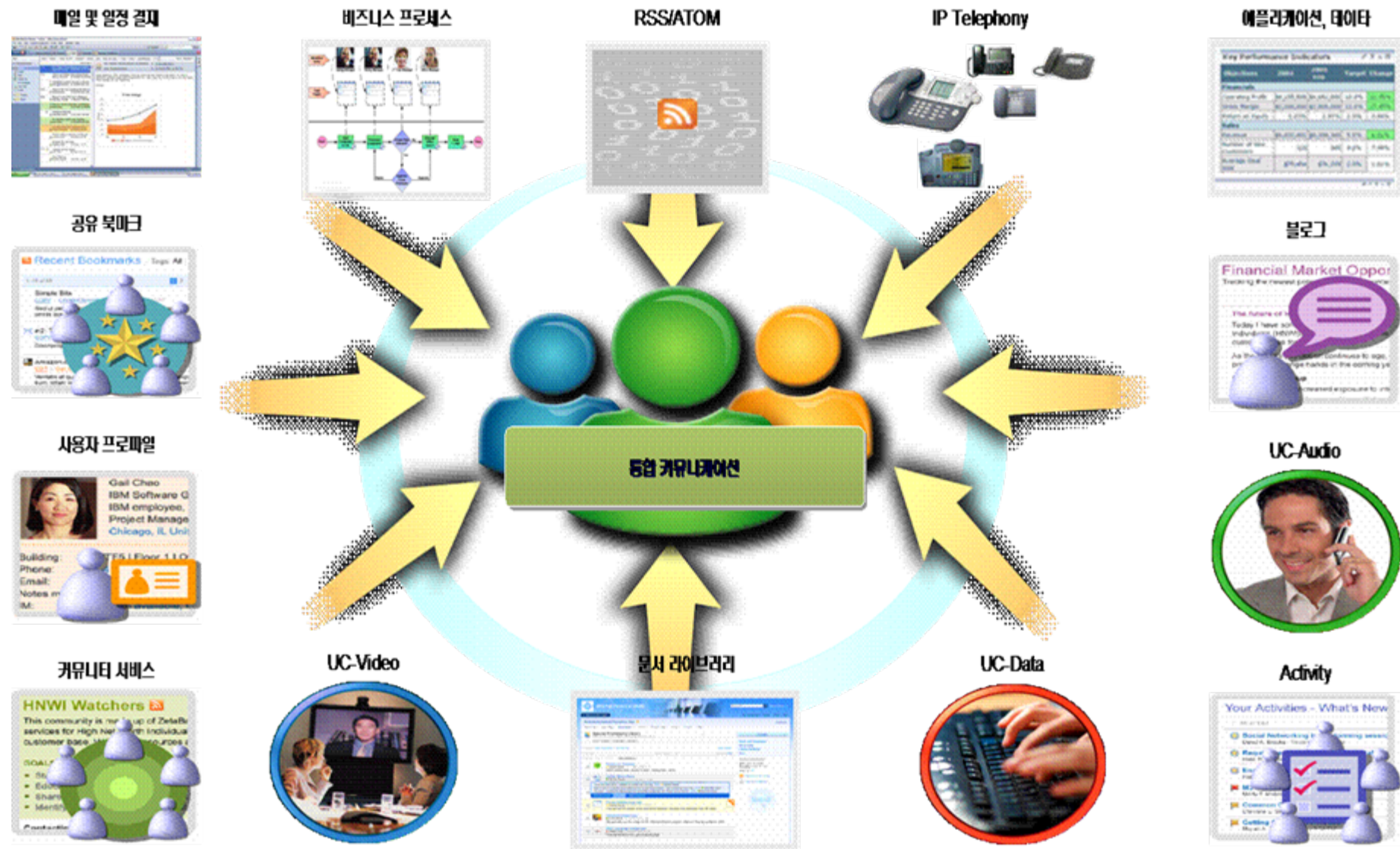

Workplace Innovation의 기대효과

Workplace Innovation은 1. 업무정황에 맞는 Collaboration 환경과 정보를 제공함으로써 업무수행시간을 단축하고, 2. 업무간의 Latency를 단축하여 기업의 end-to-end 프로세스 사이클을 단축 하게되며, 기업의 업무 생산성 향상이 이루어 집니다.

High Performance란?

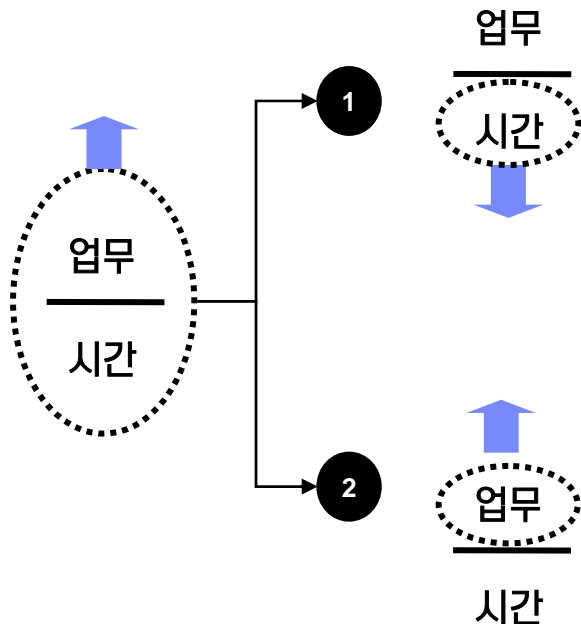

Business Impact

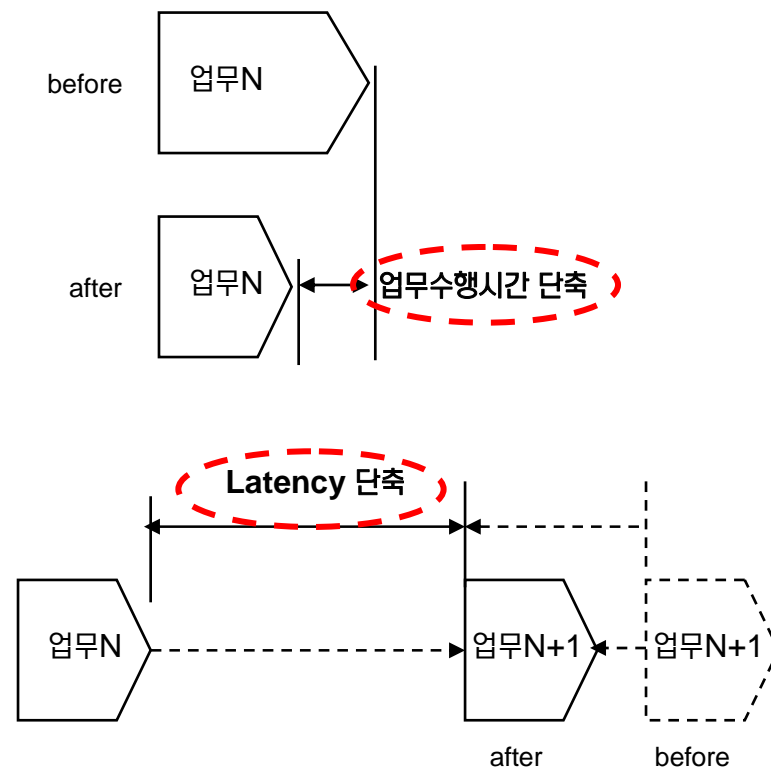

IBM Lotus Mission



**Empowering people
to be more effective,
responsive and innovative
in the context
of the work they do**



기업 요구 사항과 Lotus 협업 기술

Drive Growth

Establish strong client and partner relationships

Create Cultures of Innovation

Sense and respond to change

Innovate through collective talent

Cost Control

Leverage and preserve tacit knowledge

Develop efficient means of working

Connect Collaborate Innovate

Messaging & Collaboration

Portals & Mashups

Social Software

Unified Communications & Collaboration

Talent & Expertise

Process

Information



IBM 협업 포트폴리오

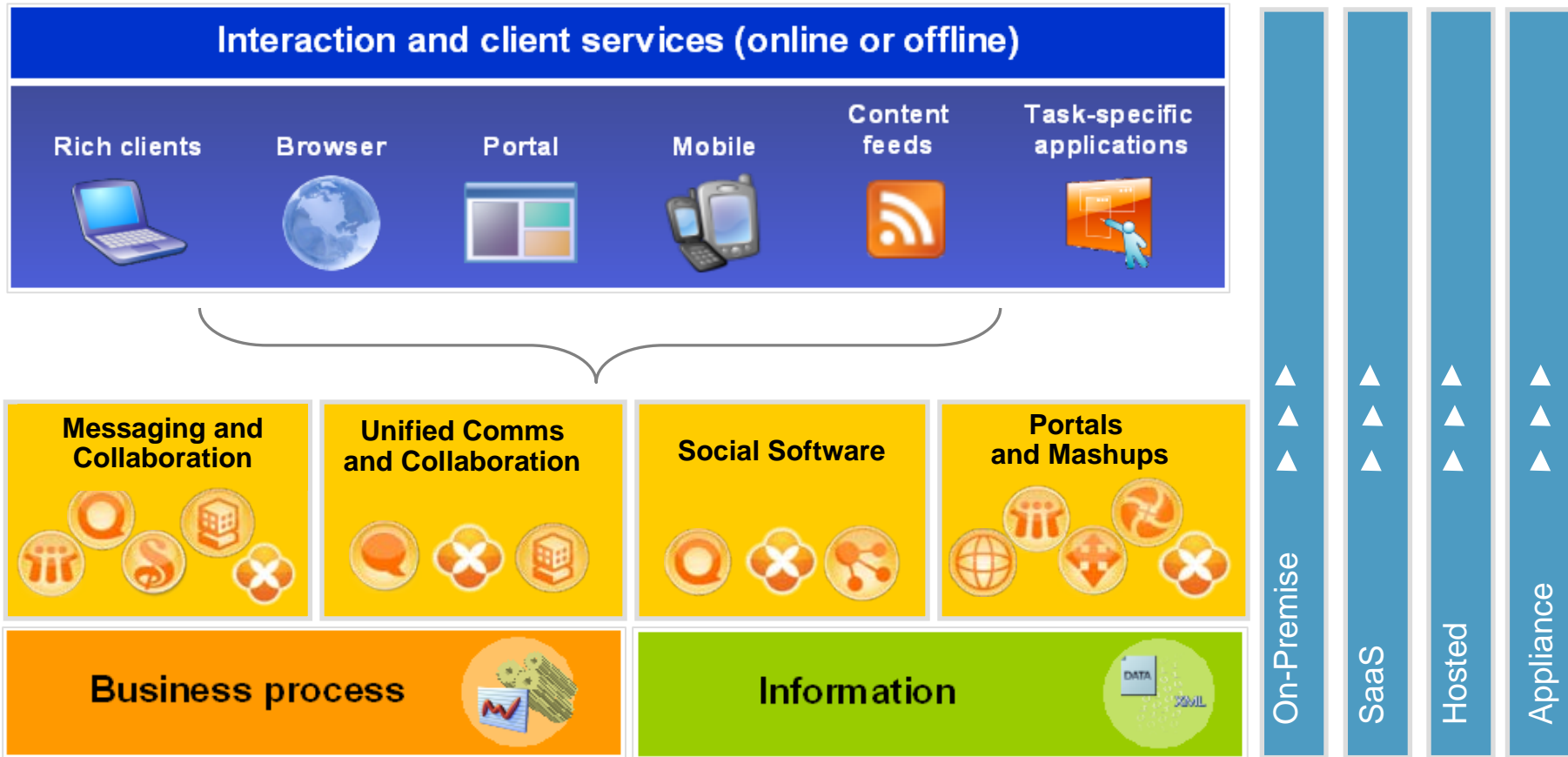

감사합니다.

