

WebSphere® software



# WebSphere Process Server 6.0 –

1.0

---

1.	WebSphere Process Server V6 .....	1
2.	SOA .....	3
	SCA.....	3
	SCA .....	4
	SCA .....	5
	.....	6
3.	.....	7
	.....	7
	.....	10
	.....	11
	.....	21
	.....	26
	.....	30
4.	WebSphere Integration Developer .....	38
	.....	38
	.....	39
	.....	40
	.....	40
	.....	45
	, .....	50

# 1. WebSphere Process Server V6

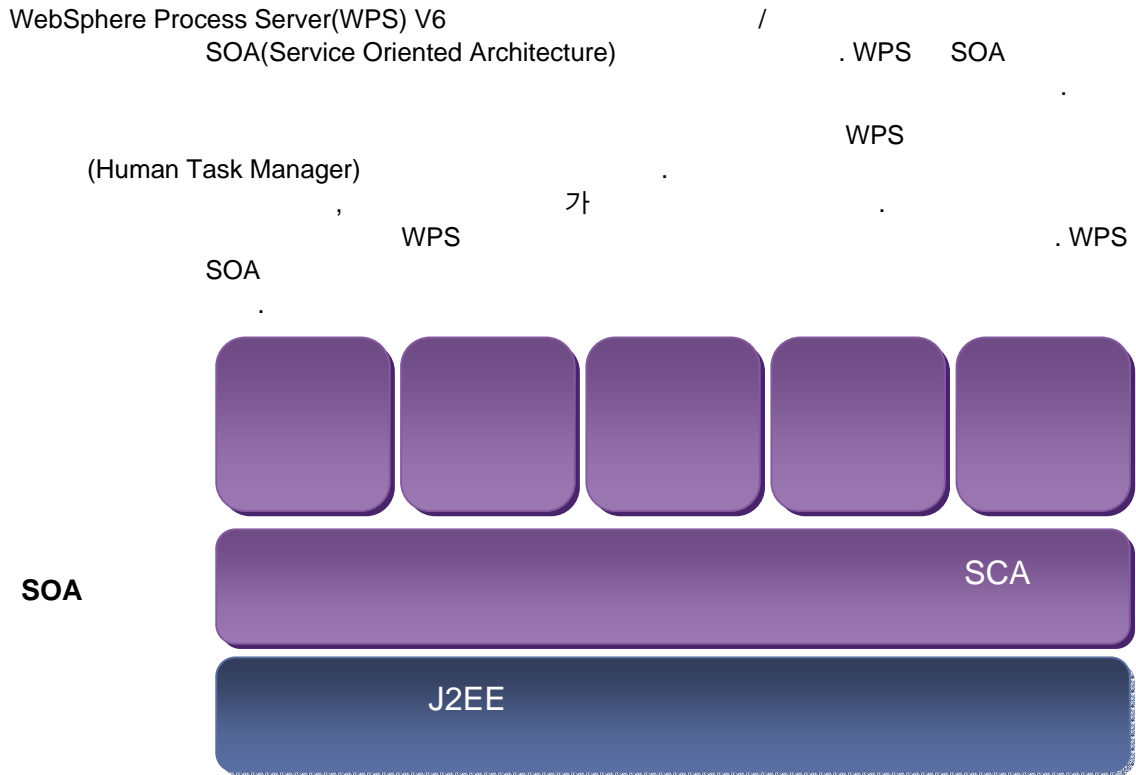

## 1 WebSphere Process Server

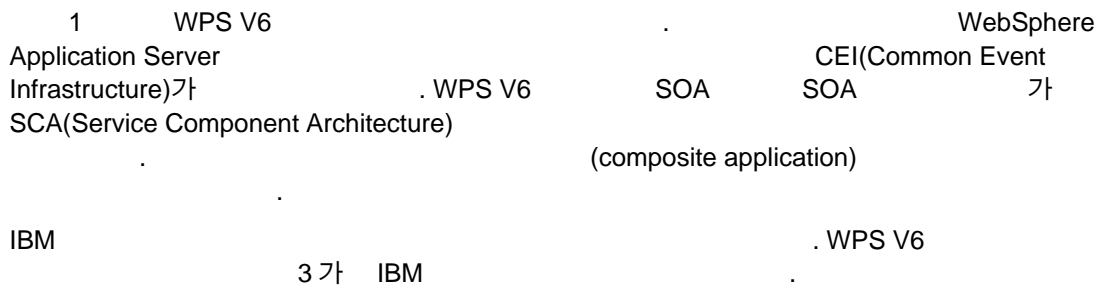

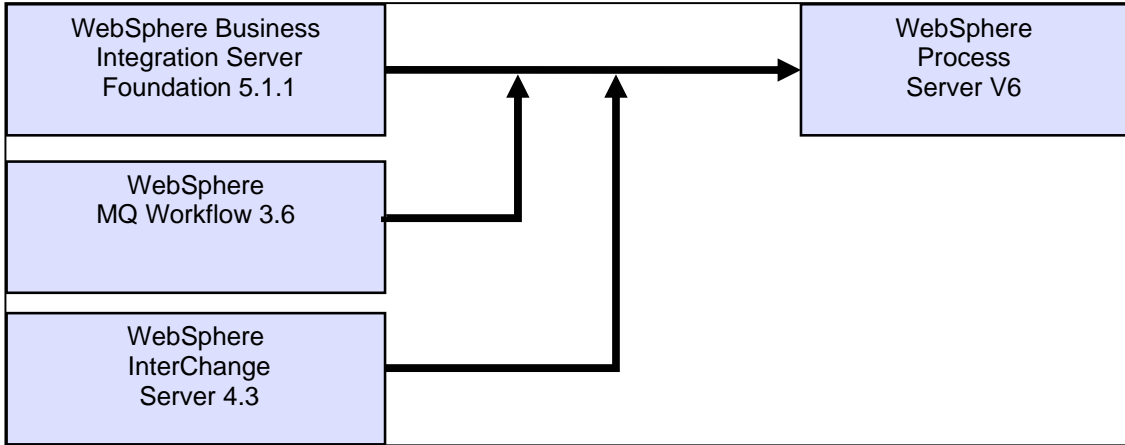

**2 3 가**

2 , WPS WebSphere Business Integration Server Foundation V5.1.1  
 WebSphere MQ Workflow WebSphere InterChange Server WPS  
 3 가

(WebSphere Application Server SOA ) 가 WPS V6

WPS V6

- SOA 2 SCA
- !

i. , WPS V6 BPEL

ii. (Human Task Manager)

iii. 가

iv.

v. 가

- 4 WPS V6 WebSphere Integration  
 Developer

## 2. SOA

SOA WebSphere Process Server(WPS) 가 . SOA . SCA

### SCA

J2EE 가 J2EE 가 3 API

3

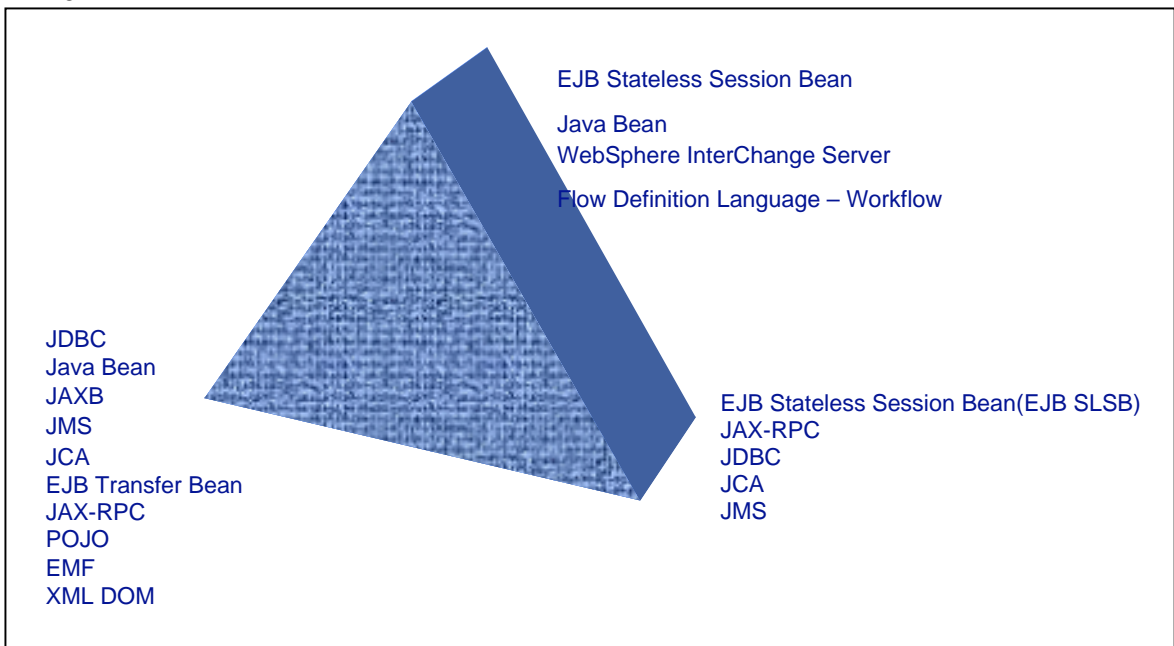

J2EE JDBC , JMS . J2EE Session Bean J2EE

BPEL

SCA

SCA 2 가 WebSphere J2EE

SCA 가  
 IT , IT  
 . SCA SCA 가 SCA  
 . IBM  
 SCA IT  
 가가 J2EE API J2EE SCA  
 SCA , EIS  
 SCA , EIS  
 SCA QoS(quality of service)  
 (lower-common-denominator solution)  
 /

## SCA

---

SOA 2 가  
 •  
 " " " " " " ,  
 " " Java CICS TP IMS  
 가  
 •  
 가 , " " , ,  
 /  
 SOA XML 가 , IBM  
 . J2EE WebSphere  
 Stateless Session Bean Entity Bean 가  
 Stateless Session Bean  
 SDO , 가 XML XSD  
 XSD XML , 가  
 SCA J2EE API

API

가

4

WPS V6

가

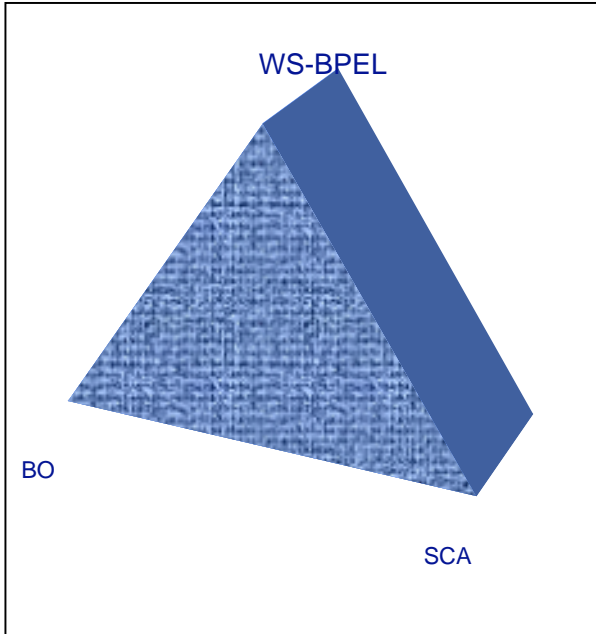

4 V6

SCA

가

Java

J2EE(

)

J2EE

## SCA

SCA

WPS V6

, SCA

가

SCA

- Stateless EJB Session Bean
- Java
- WPS
  - (Business Process)
  - (Human Task)
  - (Business Rule)
  - (Business State Machine)
  - (Transformation)

WebSphere Application Server, V6.0.1  
 Application Server  
 WebSphere Process Server(WPS)  
 Server(WAS)  
 WebSphere Process Portal  
 WPS  
 WAS V6  
 가 WebSphere eXtended Deployment  
 QoS(quality of service)가  
 QoS

WPS 가 WebSphere  
 WebSphere Application  
 WAS  
 WAS  
 WPS  
 WPS z/OS WPS

**CEI**

CEI(Common Event Infrastructure)

CEI IBM Autonomic Common Base Event /Situation Data  
 IBM CEI ( )3가 가  
 • CEI SDK. CEI SDK API (descriptive) API  
 • CEI. CEI CEI API ( : CEI )  
 • CEI. CEI  
 WebSphere , CEI WAS WAS J2EE  
 CEI 가가 WebSphere Monitor



3.

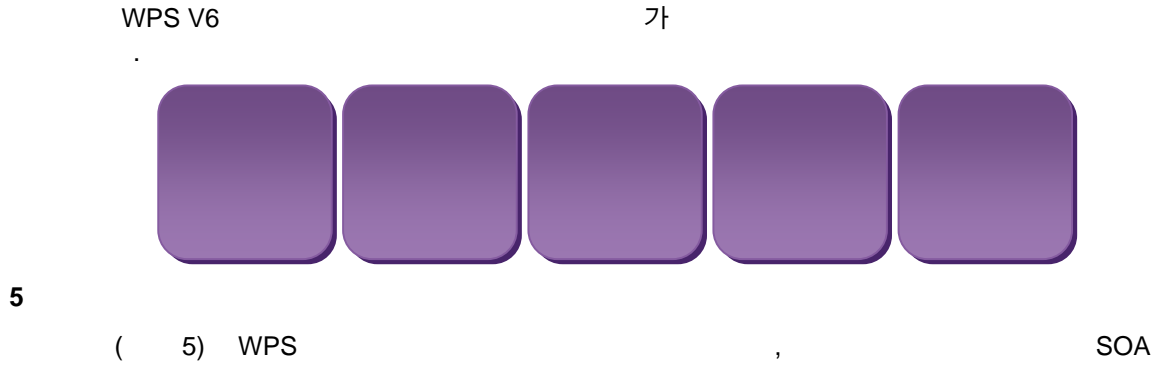

EAI(enterprise application integration) B2B(business-to-business)

가 2가 가

6 5가 가 ( ) 가

SCA / ( )

This section contains text labels for EAI and B2B, along with Korean characters '가' and numbers '2', '5', and '6'. It also includes some symbols like a slash and parentheses.

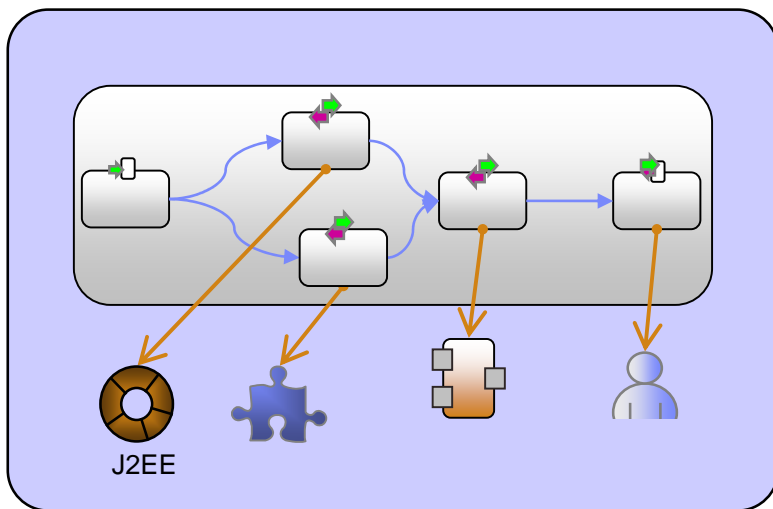

6

## WS-BPEL 2.0

WS-BPEL

가  
가

가 . WS-BPEL 2.0

WS-BPEL

WS-BPEL

WS-BPEL

가

가

/

가

WS-BPEL 2.0

XML /

. BPEL4WS 1.1

가

. WSDL 1.1, XML Schema 1.0

XPath 1.0. WSDL

, XML Schema

WS-BPEL

. XPath

WSDL

. WS-BPEL  
WS-BPEL 2.0

가

WS-BPEL 2.0

- (commit)

BPEL ( , )

•

- ( : ) XPath 1.0 - ,

•

- 가

•

-

- 가 assign

WPS V6 WS-BPEL 2.0(SCA

)

WBI

WPS V6

(

).

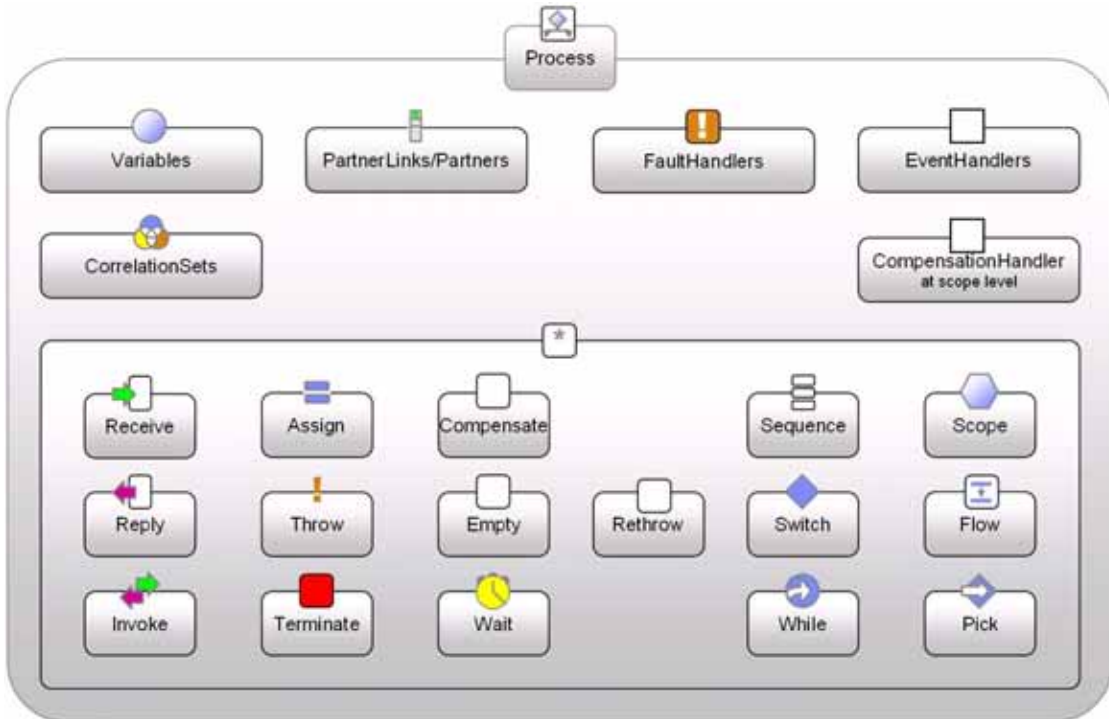

**7 WPS V6 WS-BPEL 2.0**

WPS WBI Server Foundation Version 5.1 가 . WBISF V5.1

**BPEL**

BPEL 가 가 가 BPEL 가 가

**BPEL**

. WPS V6 BPEL 가 , BPEL BPEL 가 , ( : )

**XPath 1.0**

WS-BPEL 2.0 WPS V6 XPath 1.0 ( : Transition ) . XPath ( )

WPS V6

*processTerminate*

가 , 가 . *processTerminate*  
 가 .

- *Suspend, resume.*
- *Restart.*

가

Integration Server Foundation V5.1, WebSphere ICS WPS V6 WebSphere Business  
 WebSphere MQ Workflow  
 가

### WebSphere Business Integration Server Foundation

WPS V6 WBISF WBISF WPS V6

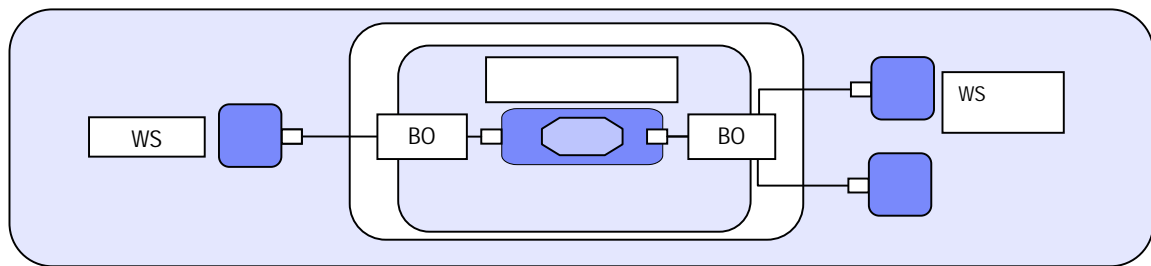

### 8 WebSphere Business Integration Server Foundation

8 WPS V6 WS-BPEL  
 V2

### WebSphere Interchange Server

WebSphere InterChange Server(WICS) ( ) ( )  
 WICS  
 WPS V6  
 (Mediation)

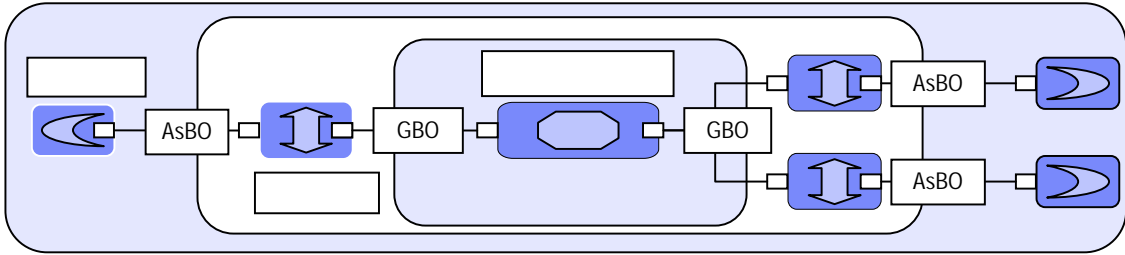

**9 WebSphere InterChange Server**

9 WICS 가 ASBO(Application Specific Business Object) (WICS 가 )WPS V6 ASBO 가 GBO(Generic Business Object) , GBO BPEL 가 GBO ASBO

**WebSphere MQ Workflow**

WebSphere MQ Workflow MQ (11 ) WebSphere MQ Workflow WPS V6

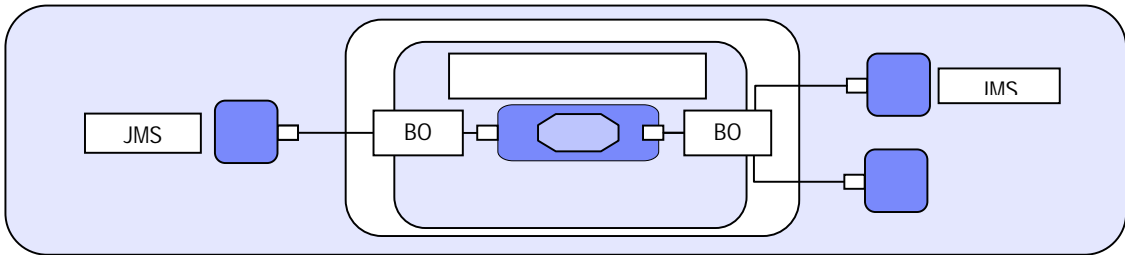

**10 WebSphere MQ Workflow**

10 가 , JMS JMS WPS V6

WPS V6

- 
- 
-

• 가  
 M2H(machine-to-human), H2M(human-to-machine) H2H(human-to-  
 human)  
 M2H WBISF (" ")  
 H2M , BPEL SOAP , CICS  
 , Enterprise Bean  
 H2H ,  
 가 " " " "  
 가 " " " "  
 (wiring)  
 , Enterprise Bean CICS  
 /  
 . HTML API BPEL  
 WorkPlace  
 ,  
 가

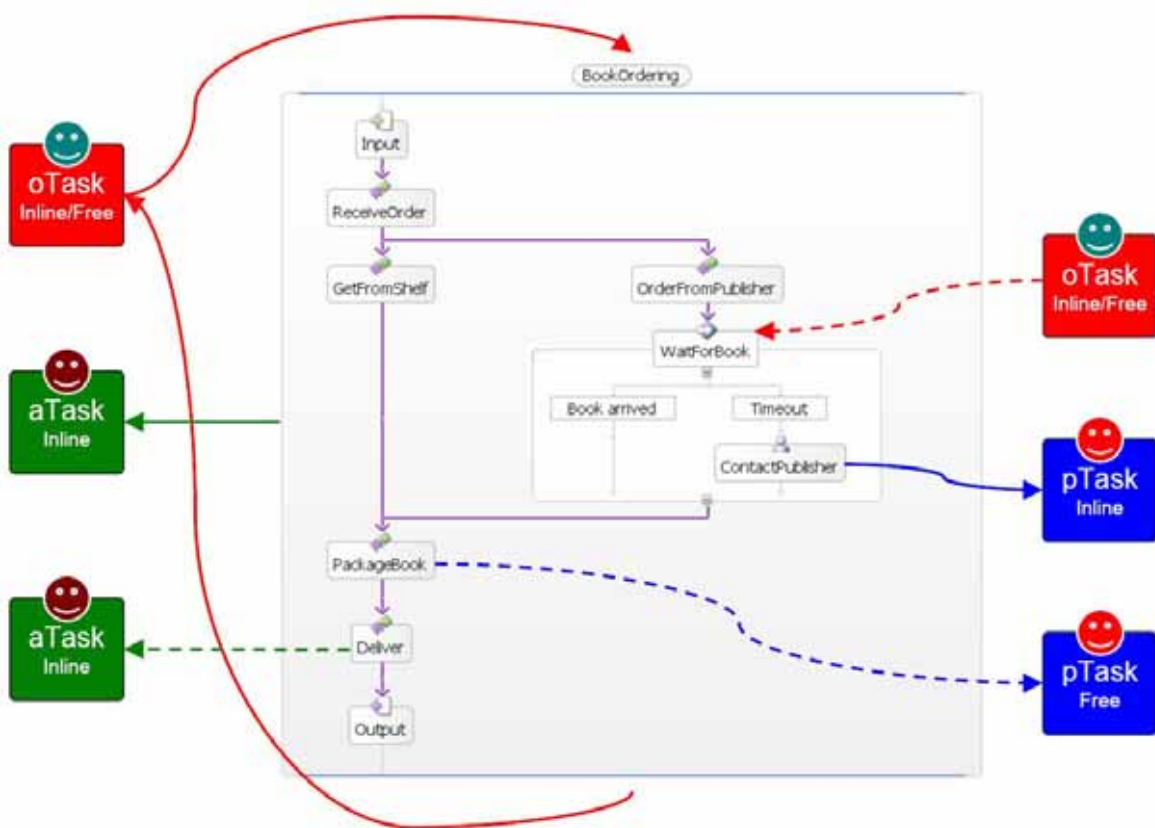

11

가

가

가

M2H, H2H

- O-Task(Originating Task)
- A-Task(Administrative Task)
- P-Task(Participating Task)
- H-Task(Human Task)
- v5

Inline Task

11

가

**O-Task(H2M)**

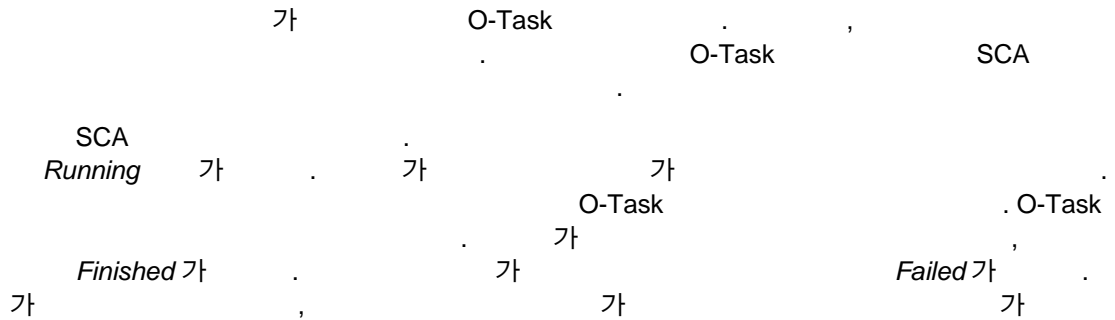

**A-Task**

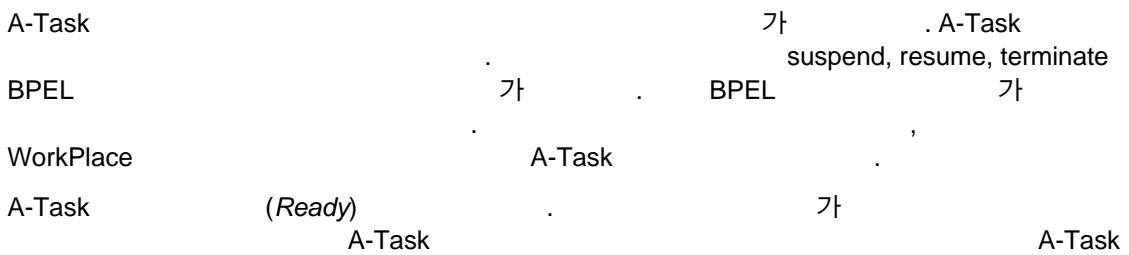

**P-Task**

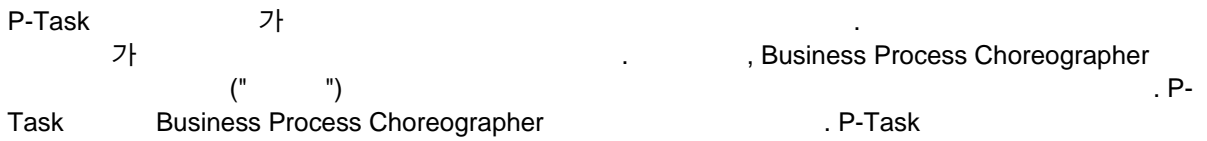

**H-Task(H2H)**

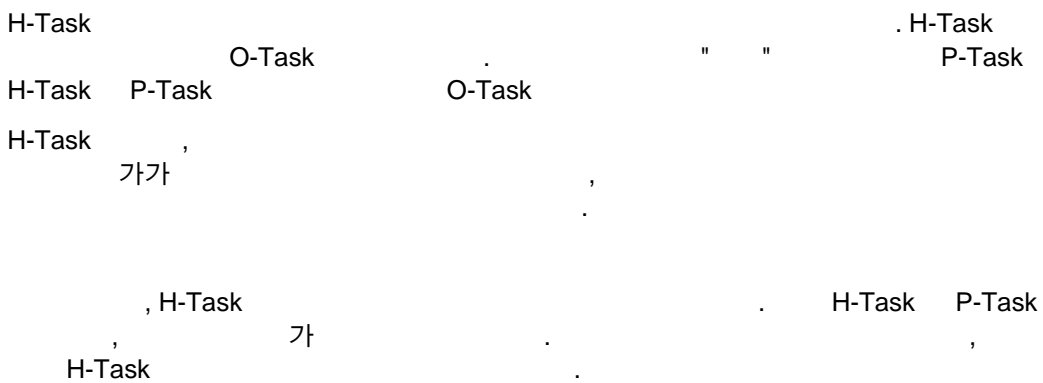



12).

3가

가

- : / ( 가 )
- : 가 ( IBM )
- : 가?, / ,

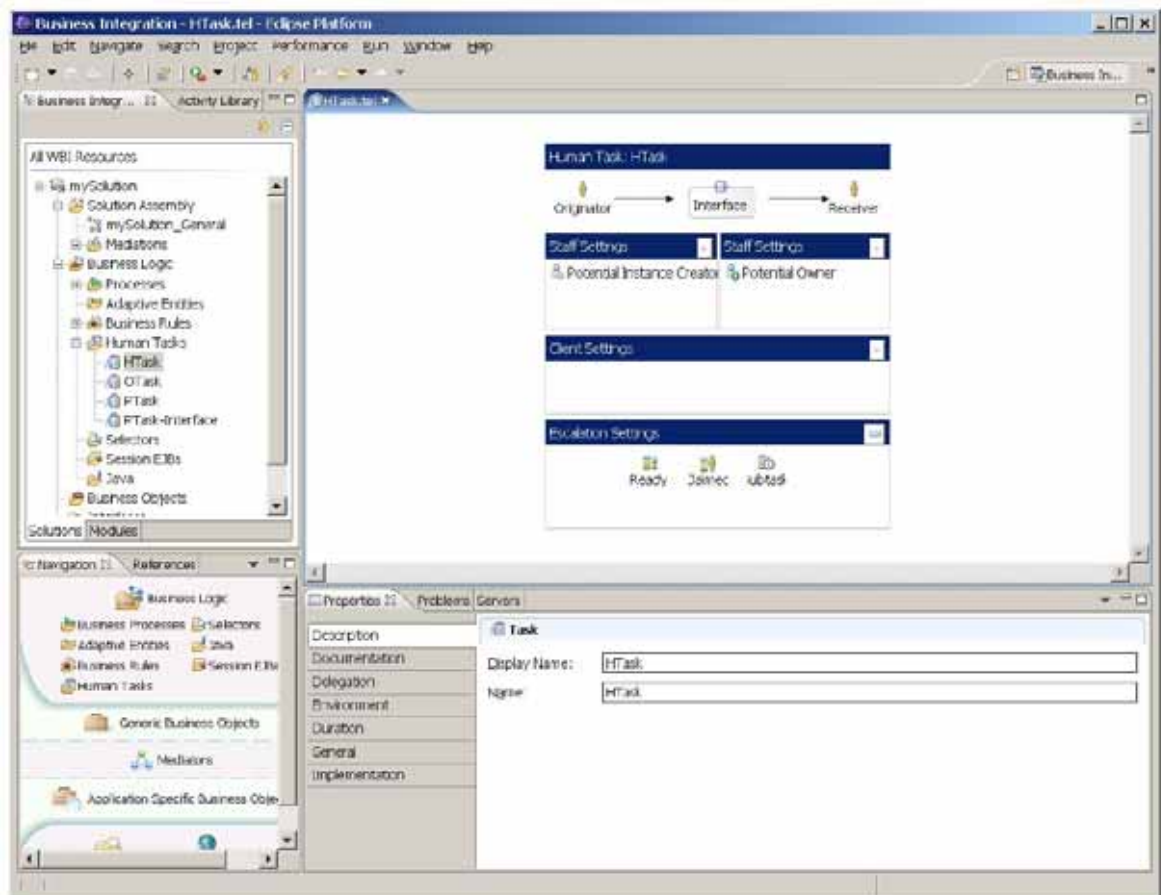

12

13

- O-Task 가 ,
- A-Task
- P-Task

- H-Task, P-Task
- v5 Inline Task
- D A 가
- 가
- 가

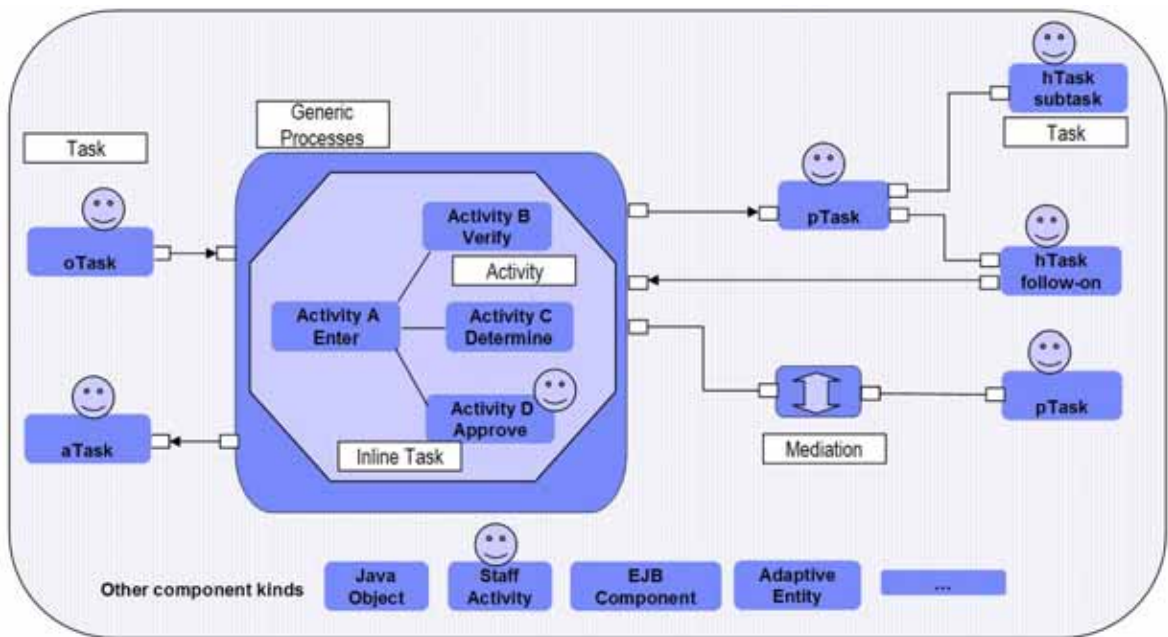

13

" 가 Ready 가 Ready, Claimed WaitingForSubtask (claim) Claimed 가  
 Finished 가 H-Task 가  
 Failed 가 WaitingForSubtask 가 Escalated Suspended Escalated 가  
 가 H-Task P-Task 가  
 14 H-Task P-Task 가

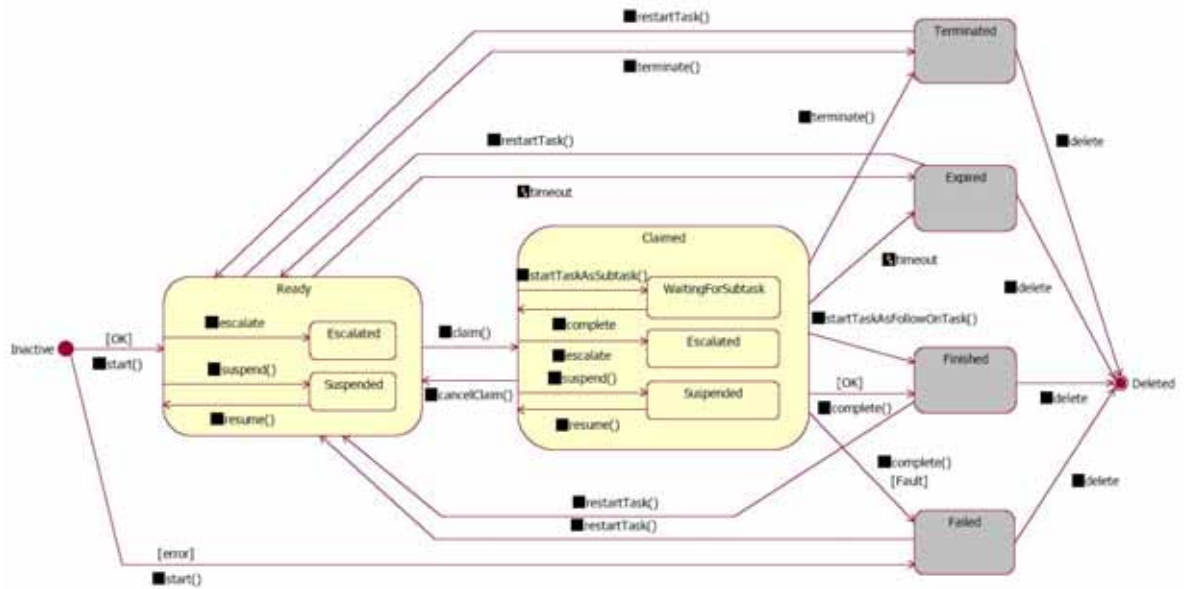

14 P-Task H-Task

(authorization)

WBISF V5.1 가

<p>A-Task H-Task O-Task P-Task</p>	
--	--

15

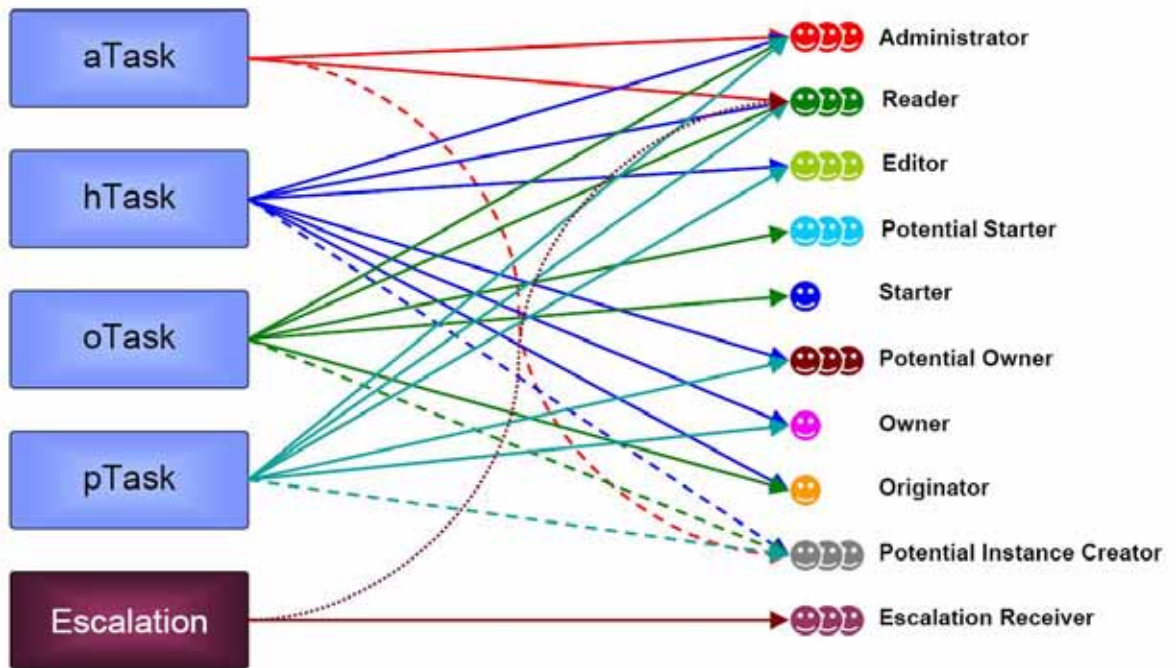

<p>A - Task H - Task O - Task P - Task</p>	
--	--

15

(surveillance )

	1		
--	---	--	--

		2	3
--	--	---	---

16

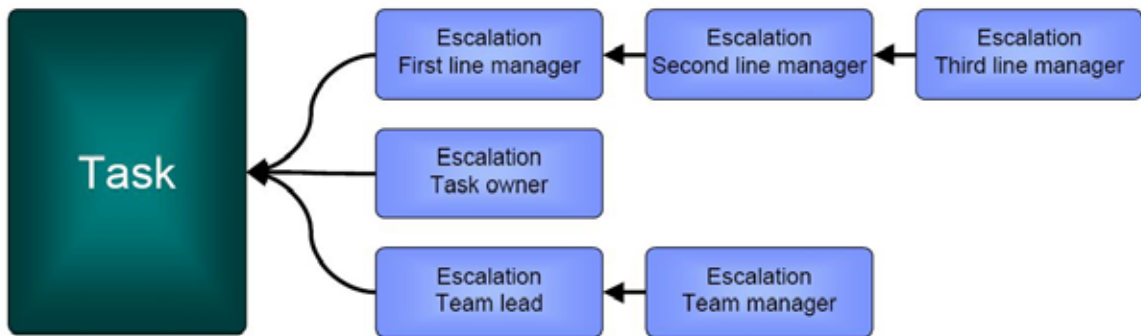

	1	2	3
--	---	---	---

16

가 claimed 가 1 가  
 가 1 가 , 3 가  
 가 1 2 3  
 가 2 3  
 가

- 가 setter 가 ( : displayName, description)
- *waiting* 가 가 ,
- *surveillance* *atLeastExpectedState* 가 가  
*escalated* , *superfluous*  
2 가  
가 가 , autoRepeatDuration  
0
- 
- 
- 가
- 가 increasePriority 가 ID 가

- Workflow 가 WBISF v5.x WebSphere MQ
- O-Task, A-Task, P-Task, H-Task Incline
- BPEL
- H2H H2M ad hoc
- ,
- 가
- ( )
- 가 "claimed"
- " " 가 , ,

- CustomProperty WebClient 가 가

WebSphere MQ Workflow WBISF

SCA

가 / 가 , 가 , 가  
 ( , ) 가 , 가  
 ( , ) 가 가 . 가  
 ( , ) 가 가 .  
 stateful BPEL . BSM(Business State Machine) 가  
 (state machine) . BSM  
 BSM  
 17 BSM stateful . 가 BSM  
 WSDL UML . BSM XML BSM  
 SACL(State Adaptive Choreography Language) 가 SACL  
 WSDL SCA , UML 가

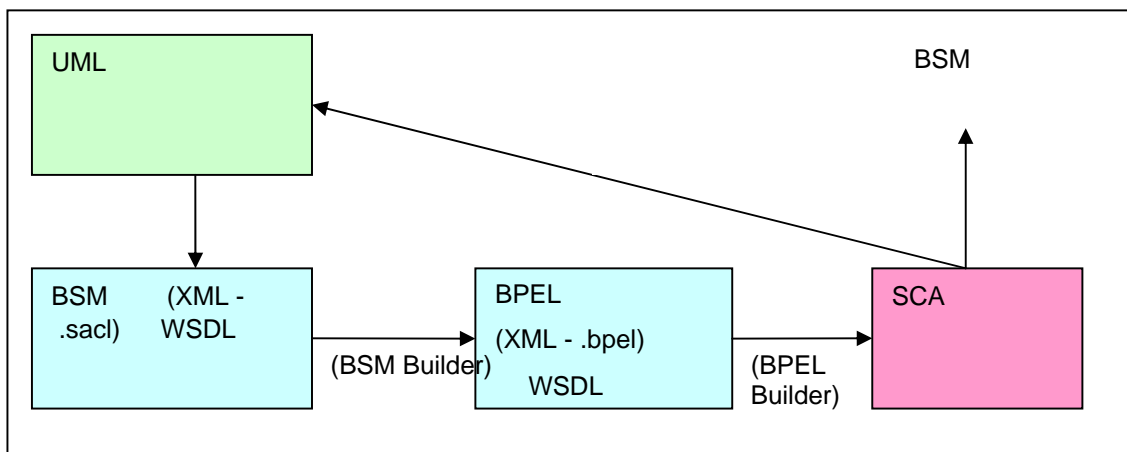

17 BSM

BSM SCA guard  
 , BSM BSM  
 BSM 가 BSM GUI 가 BSM  
 가 가 BSM  
 stateful 가

BSM WPS BSM UML 2.0  
 UML 2.0 가 BSM /  
 guard 가 UML

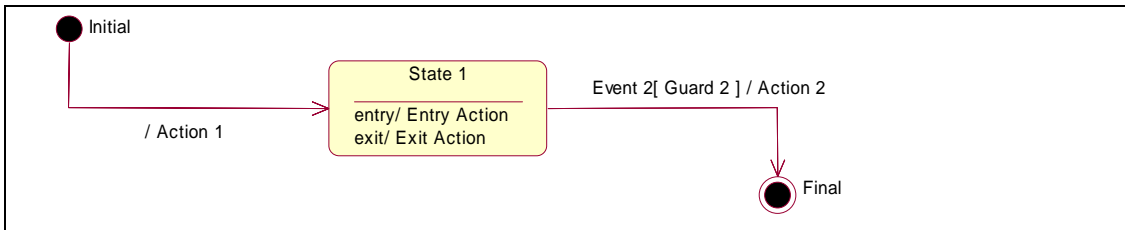

**18 UML 2.0**

BSM  
**SCA** : (operation)  
 ( : state)  
**State:** BPEL BPEL  
**Event:** SCA  
 가  
**Guard:** non-mutative Boolean Java snippet  
 SCA  
**Action:** 가 ( guard 가 true 가 )  
 Java snippet SCA  
**State Exit Action:** 가  
 Java snippet SCA  
**State Entry Action:** 가  
 Java snippet SCA



guard, action, state exit action state entry action  
 , UML ( 2 ) initial State 1  
 가 guard 가 ( ).

BSM 18 가 19 BSM

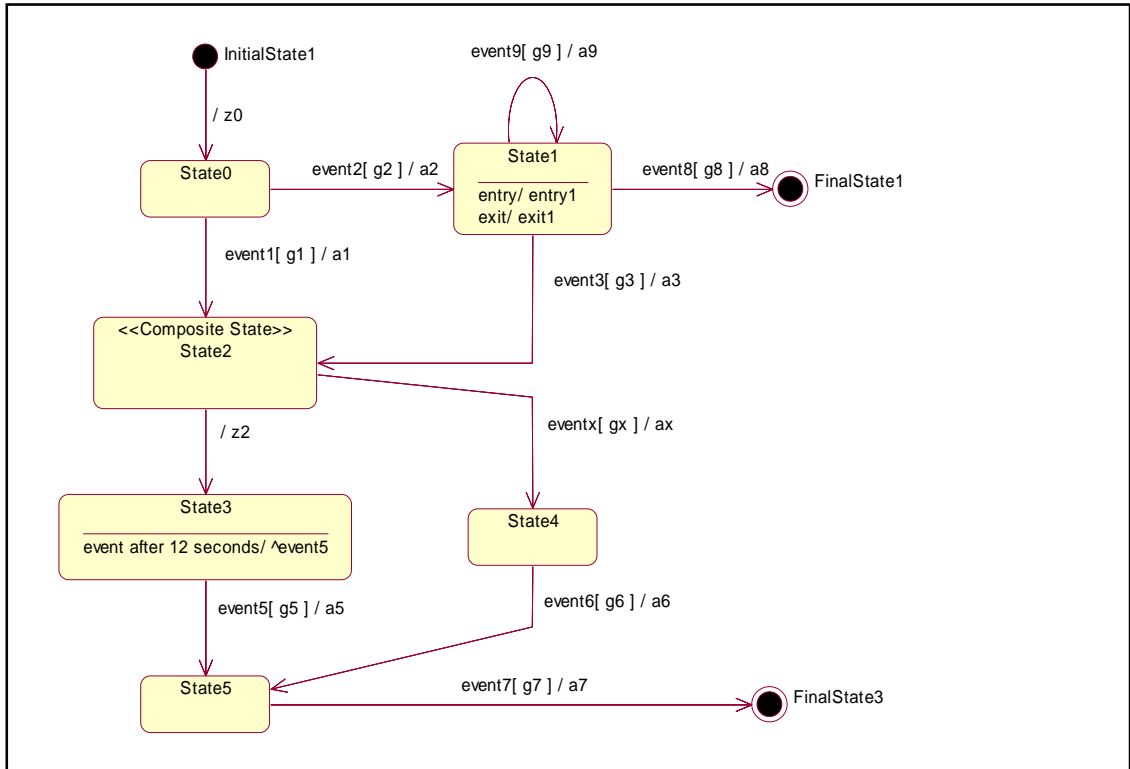

19

InitialState1( ) , (pseudo-  
 state) 가 ( State 0).  
 가 , guard 가 ( 3 z0).  
 19 State 0 event1 event2 2 가 State2 State1  
 . event2 가 , guard g2 State 0  
 1 (entry1) 가 a2 가 State  
 • event8 event3 State 1 exit1  
 • State 1 event9 ( 가 )

/ 3 4  
 1 guard, action state exit state entry  
 2 BPEL a1 , a1 2 가  
 SCA  
 ( ) 가  
 3 State 3 12 가 event5 가  
 ( : guard g5 가 )  
 State 2 가

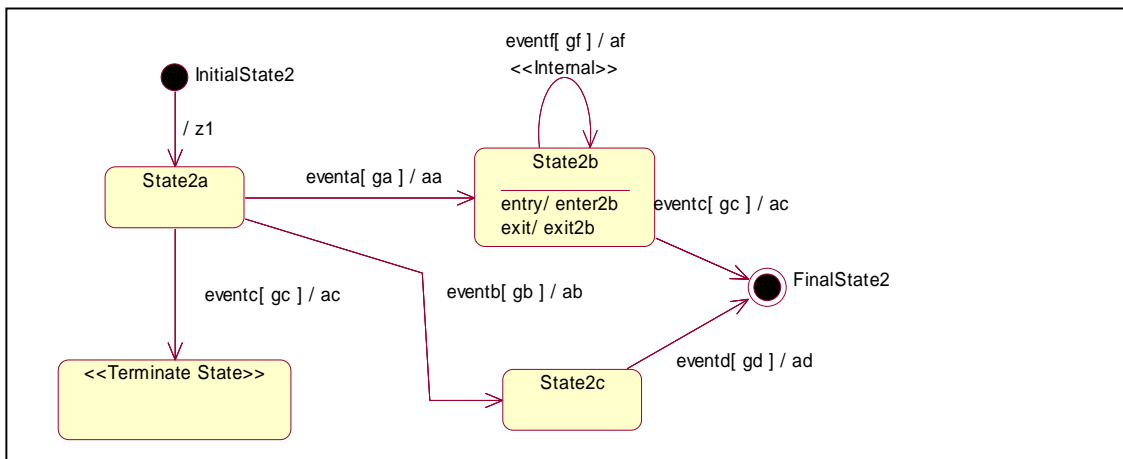

**20 State 2**

SACL . event1 20 State2 가  
 State2  
 ( InitialState2)  
 (State2a).

- (terminate state)

(final state)가

가

- (FinalState2) 3 State2 , guard (z2)

- UML 2 가 (nested) (enclosing) eventx 가 , 3 eventx 가 가 가

21

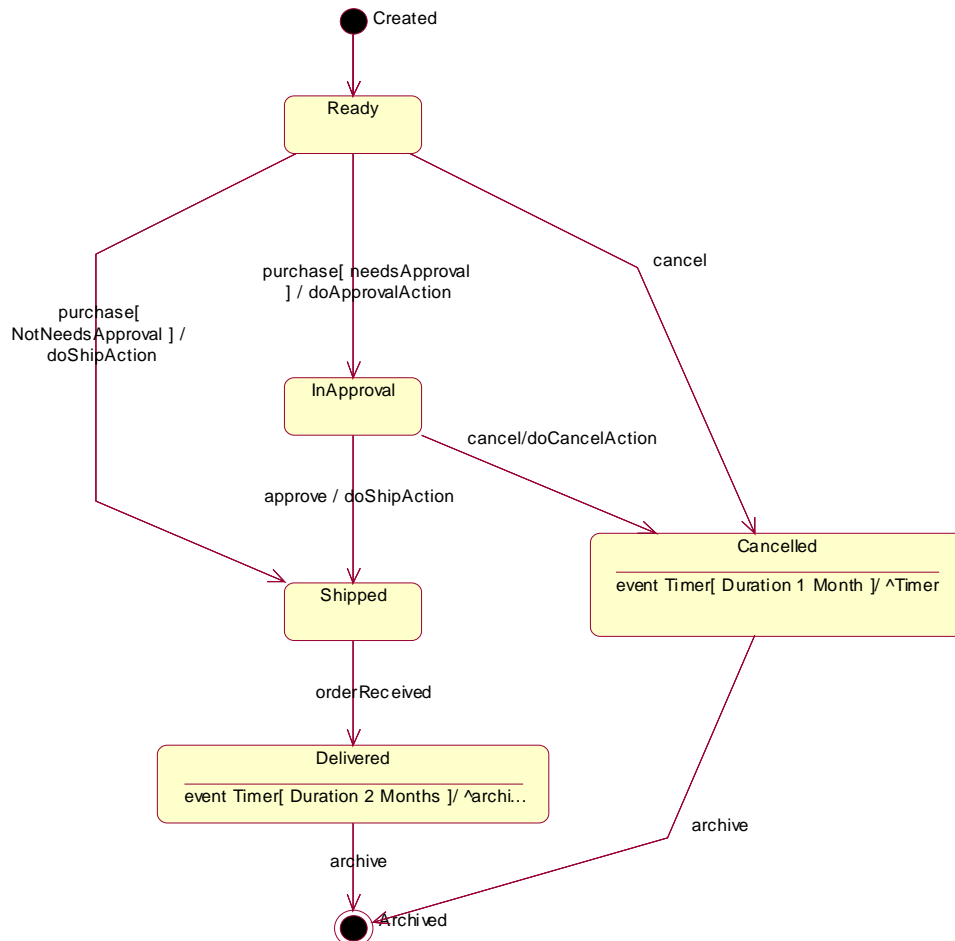

21

```

Created
Ready
Ready purchase cancel 2 가 . purchase 2
guard , needsApproval NotNeeds Approval /
, 가 . 가
, guard . needsApproval
hApproval 가 NotNeedsApproval
Shipped
hApproval cancel approve guard 가 . approve
Shipped . Cancelled ( )
Timer 가 . Cancelled 1
Shipped orderReceived Delivered 2
timer 가 , Archived
Archived

```

---

2 가 ( ).

- If/then
- 

가

Eclipse 가

# SOA

가  
 SCA  
 WBI  
 가  
 ( )  
 1..n  
 WBI SCA  
 , Java Java  
 1..n  
 /

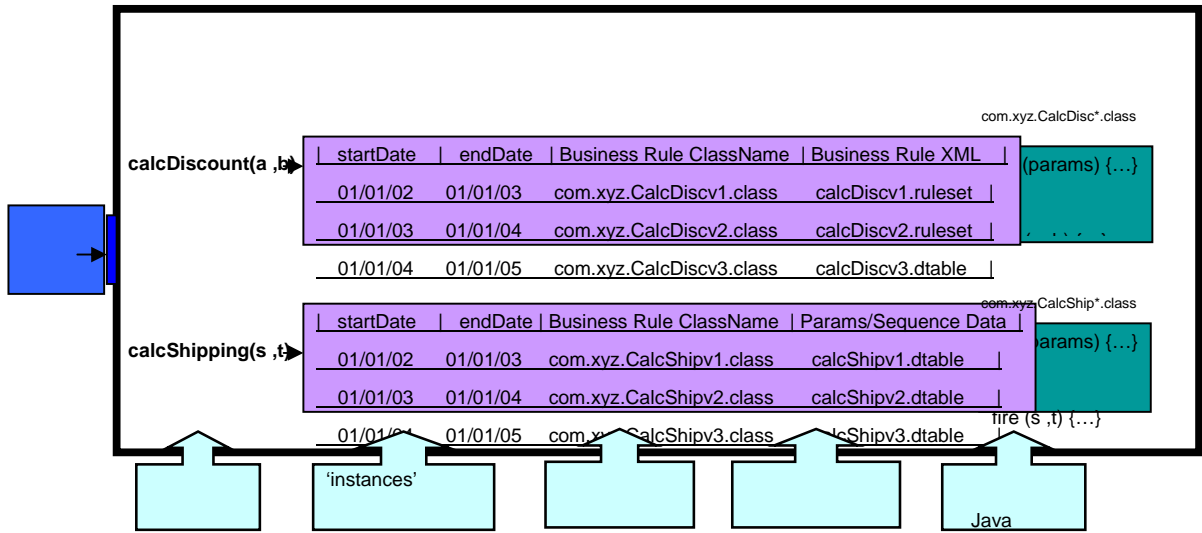

22

/ , WBI  
 가

**If/then**

if/then if/then , 'if' , 'then' 가 . true  
:  
:( )

```
DiscountRulesetOkay {
  discount = 0.0 // initialize return variable, essentially another rule
  If purchase.order >= 100.00 then discount = .05
  If purchase.order >= 500.00 then discount = .10
  If purchase.order >= 1000.00 then discount = .20
```

:  
가 = \$50.00  
3 가 가,  
= 0  
가 e = \$250.00  
3 가 가, 1  
= .05  
가 = \$750.00  
3 가 가, 2  
= .10  
가 = \$1000.00  
3 가 가, 3  
= .20  
If/then 가 ( , , 가 ) 가 , if/then 가  
4 가 if/then 가  
if/then 가  
/ 가 , 1 가 , 가 ,



- ( , , / / )
- if/then
- /
- 가 ( , WPT) if/then .

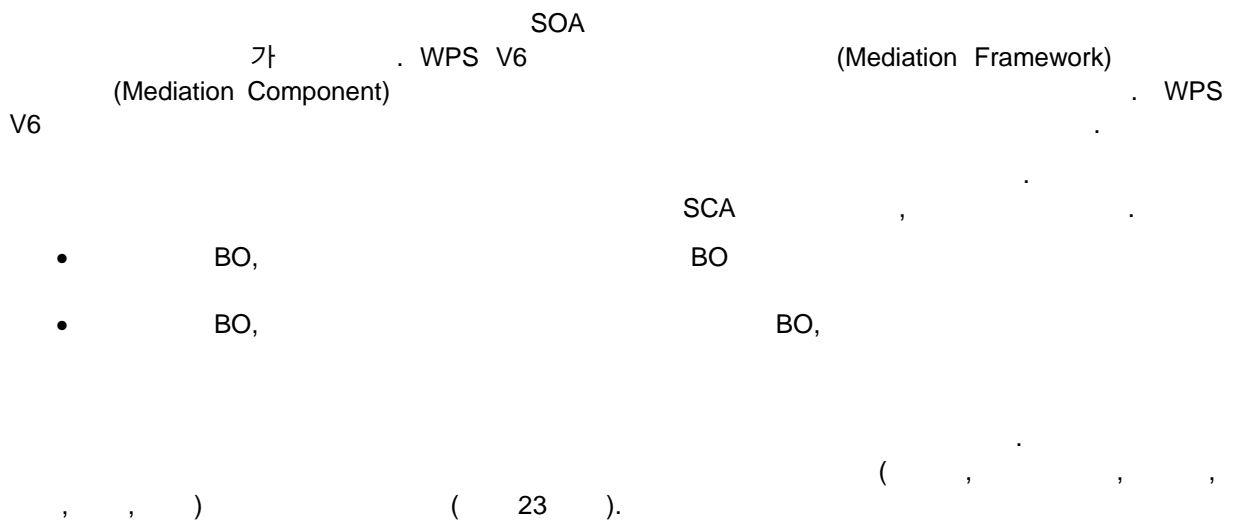



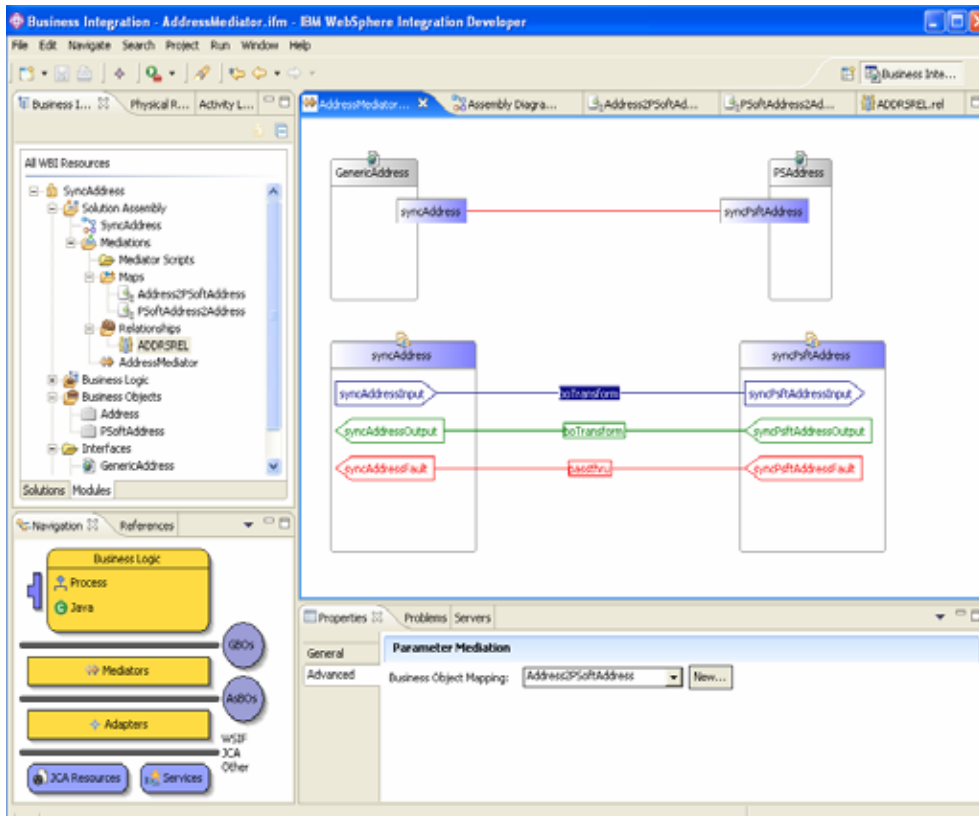

23

가

가

/

(lookup)

ID

가

가

(

가

)

:

SCA

24

(cancelOrder)

(updateOrderStatus)

( :

).

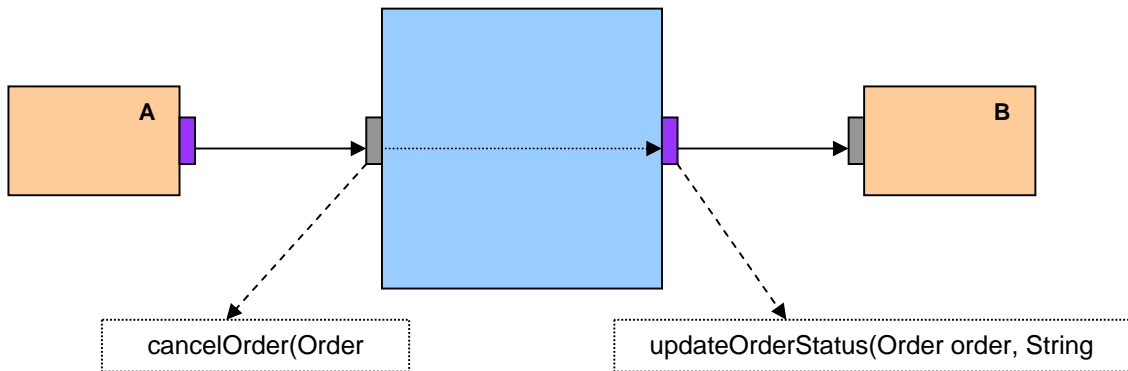

24

25 OrderManager  
가

SAP

" " 가 , 가 , 가

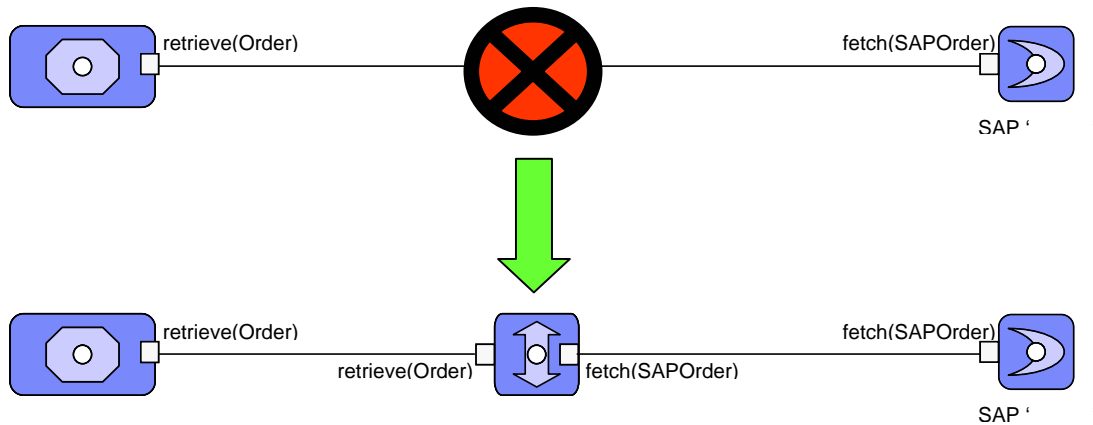

25

:

가

. WPS V6  
Move/Join/Extract/Assign

Java

( 31 ).

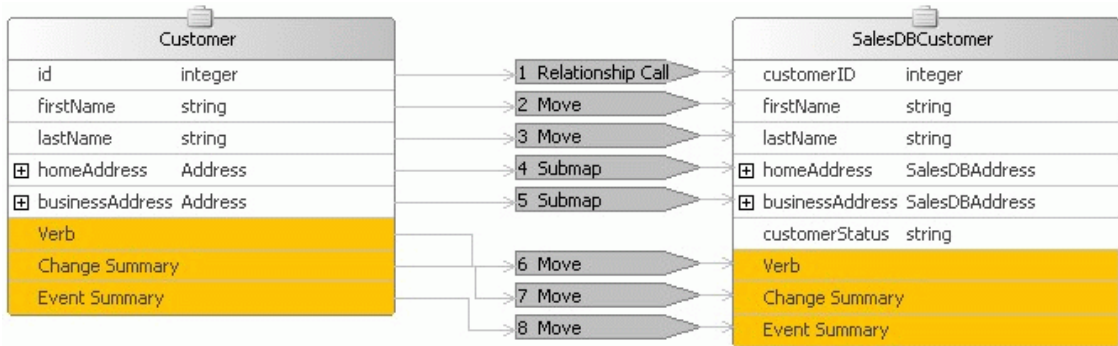

26

( )

ASBO( : SAPCustomer, SAPOrder) CRUD(Create, Read, Update, Delete)  
 EIS , GBO( : Customer, Order)

가 , ( ) /  
 ( ) 27

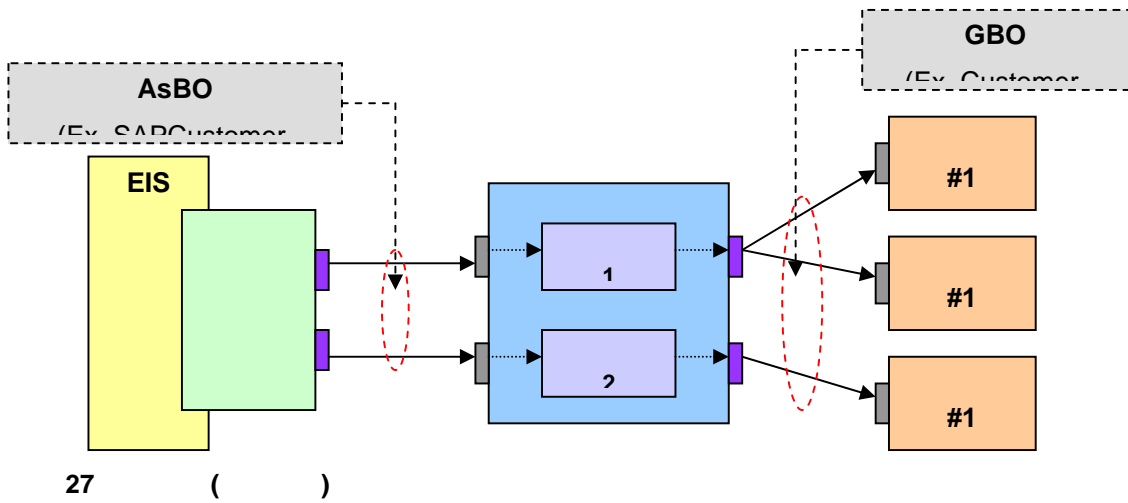

27 ( )  
 ( )  
 가 GBO( : Customer, Order) EIS ( : SAP) , ASBO( :  
 SAPCustomer, SAPOrder) CRUD

28

가 /

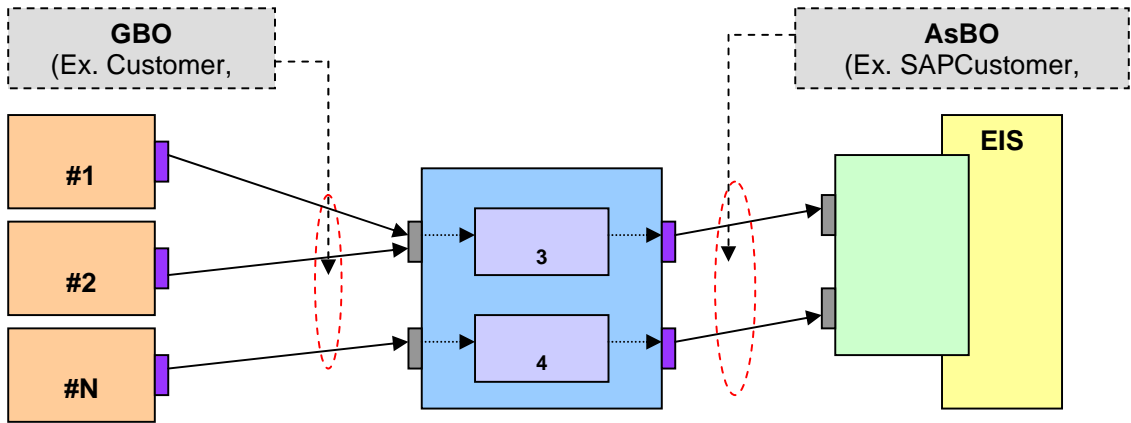

28

: ID

가

( : )

. WPS V6

가

WPS

WPS V6

ID

( : TX = Texas, NC = North Carolina )

(Relationship Designer)

29

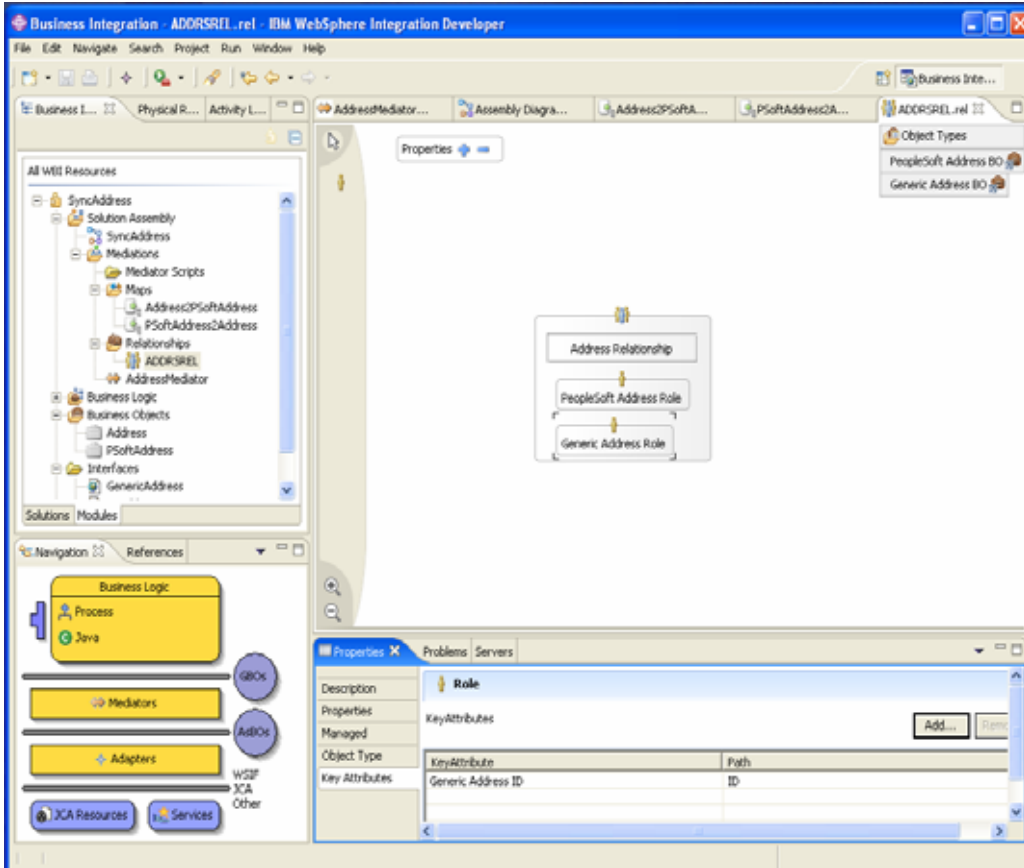

29

30) . EIS Create ( :SAP createCustomer) ( WPS V6 가 EIS ID( :SAPCustomerID) ID( :CustomerID) Customer 가 , EIS( :Siebel) CRUD 가

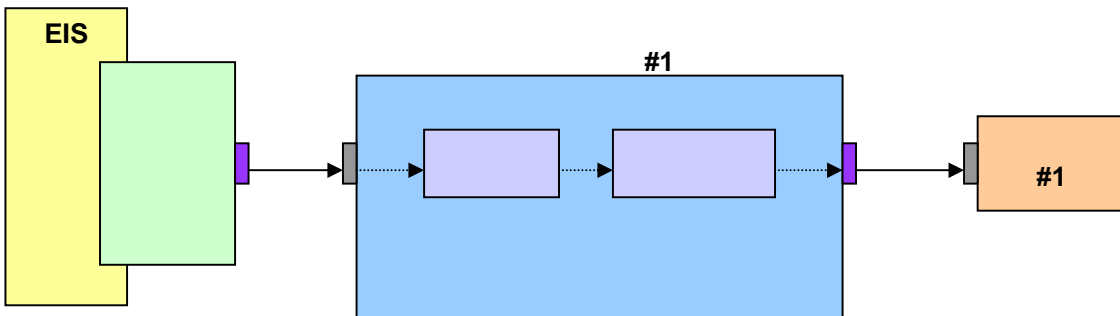

30

WBI

WBI

- 
- 
- 
- 
- 

가

Jservice

가

( 31 ).

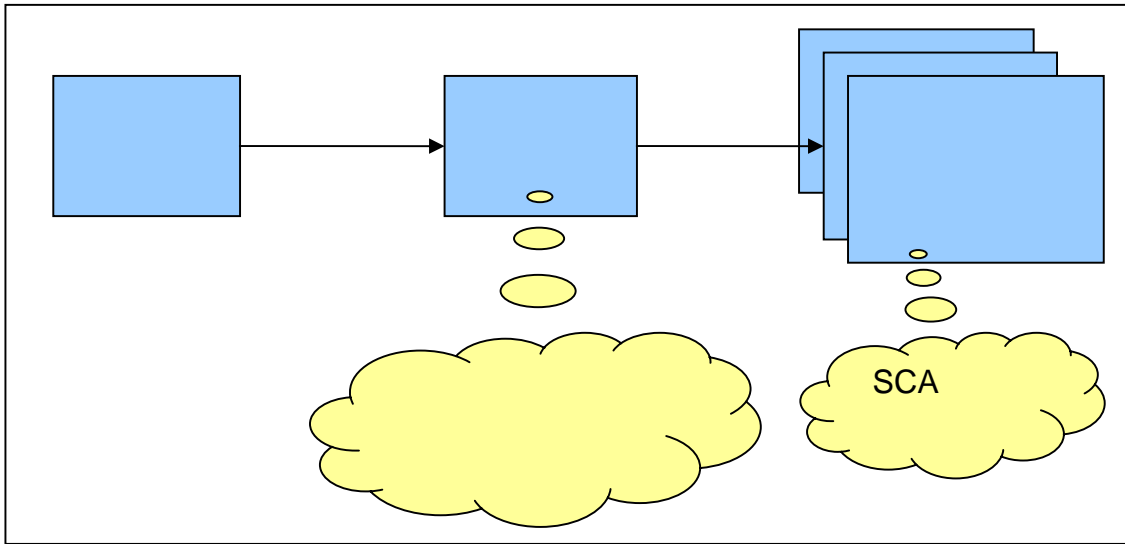

31

\_\_\_\_\_ :  
가

. SCA

\_\_\_\_\_ :

SCA

\_\_\_\_\_ :

SCA

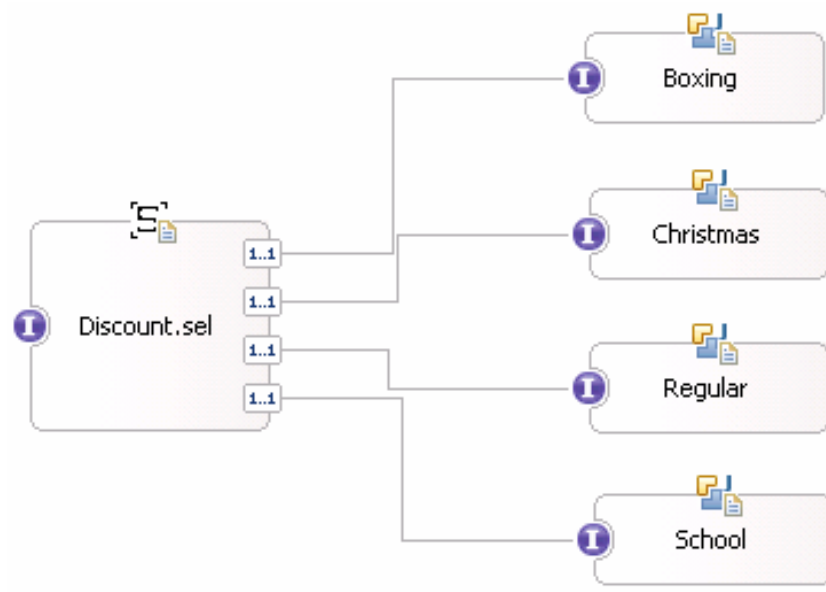

32  
32  
Discount

가

SCA

# 4. WebSphere Integration Developer

WebSphere Integration Developer v 6.0 WPS 가 IDE  
 Eclipse 3.0 , " 가  
 Rational Application Developer v6.0  
 Integration Developer 가  
 가 (bottom-up) / (top-down) 가  
 가

WebSphere Integration Developer SCA Integration Developer

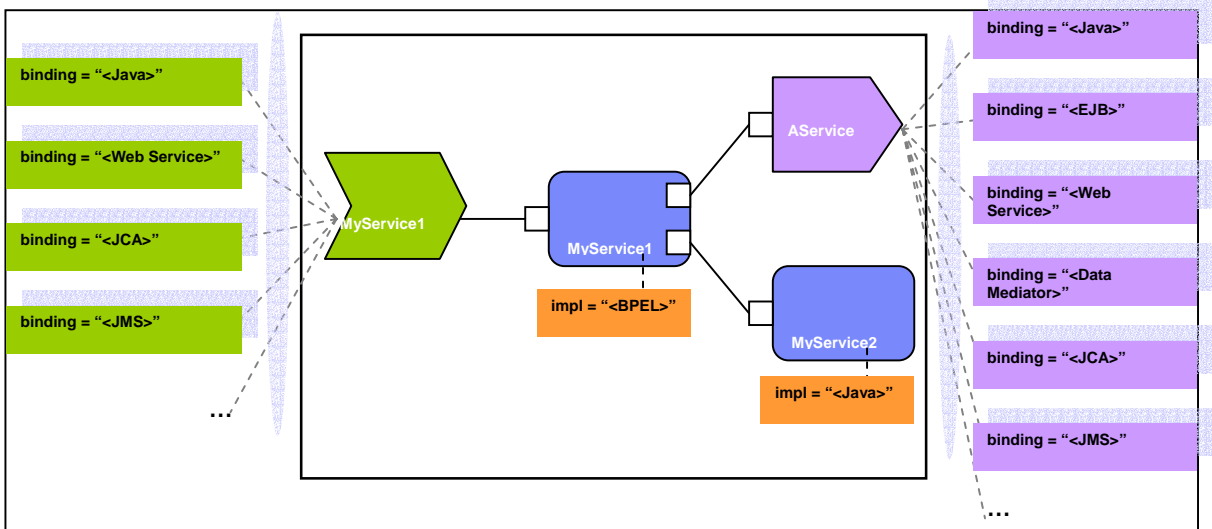

33 SCA

가  
 WebSphere Business Integration Server



SCA

WDSL

Java

가

" "

**(Wire)**

가

**(Service Qualifier)**

QoS

**(Service Implementation Type)**

WebSphere Integration Developer

가

BPEL

, EIS

SCA

가

/

가

/

가

( : EJB,

, EIS

)

2가

가가

가

가

Integration Developer

Integration Developer

가

가 EIS , Java 가  
 가 가 ,  
 가 ,  
 J2EE  
 Rational Application Developer WebSphere Integration  
 Developer .

---

WebSphere Integration Developer SOA .  
 Developer WebSphere Integration  
 J2EE Connector Architecture  
 JMS . WebSphere Integration Developer SOAP  
 BPEL . WSDL .  
 가 가 가  
 WebSphere Integration Developer .NET  
 SCA .

---

WebSphere Integration Developer 가 , 'meet-in-the-middle'  
 Integration Developer WebSphere

**Business Integration perspective**

Business Integration perspective 34  
 가가 , , 가 .

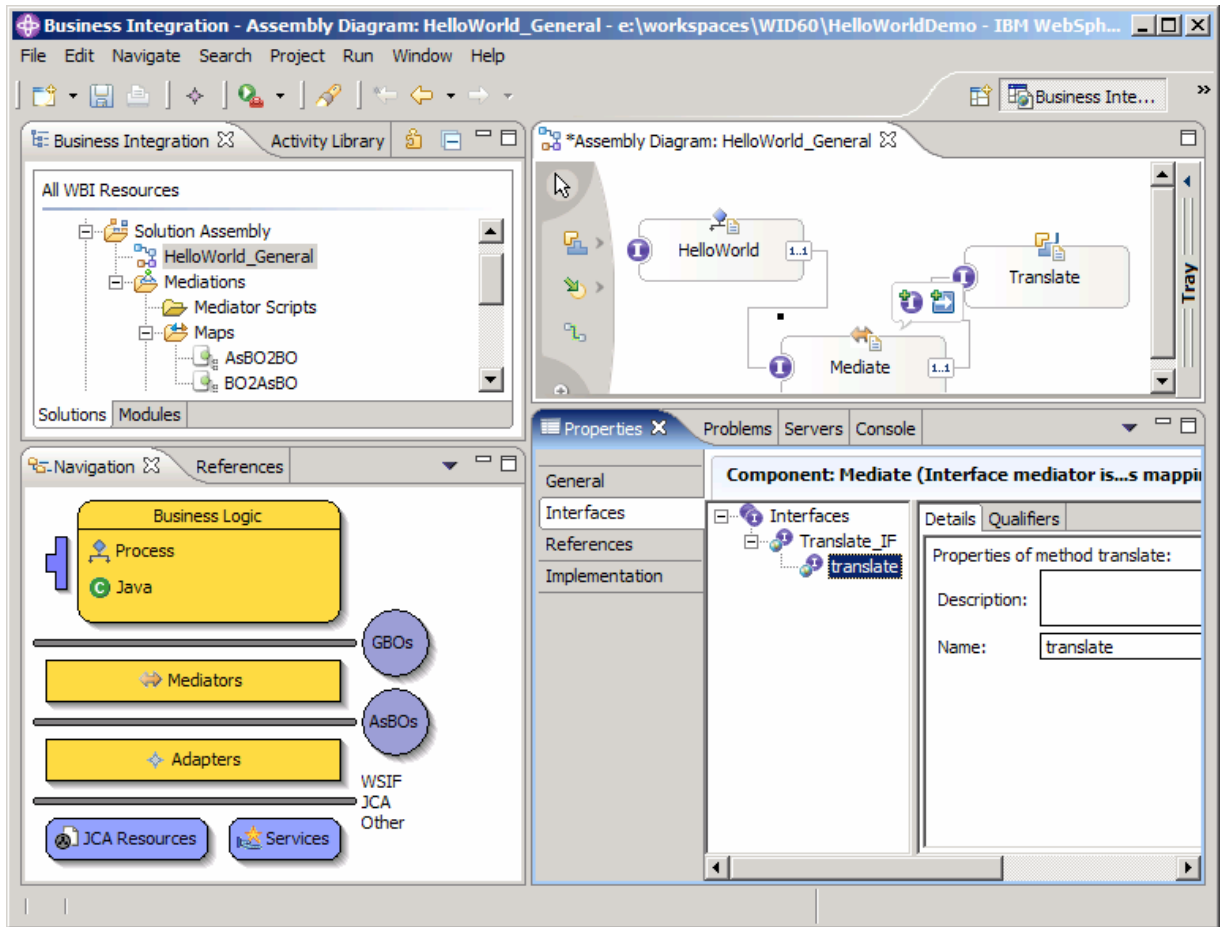

### 34 WebSphere Integration Development

가

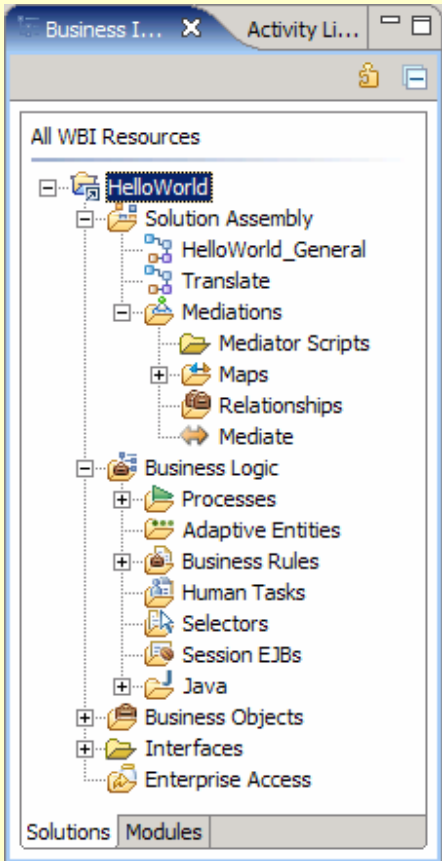
	Solution Assembly	가 가 가
	Business Logic	가 Processes(BPEL), Business State Machines( Adaptive Entities ) , Business Rules, Human Tasks, Selectors, Session EJBs Java beans
	Business Objects	가
	Interfaces	가
	Enterprise Access	JCA EIS 가 ( : Exports, Imports )

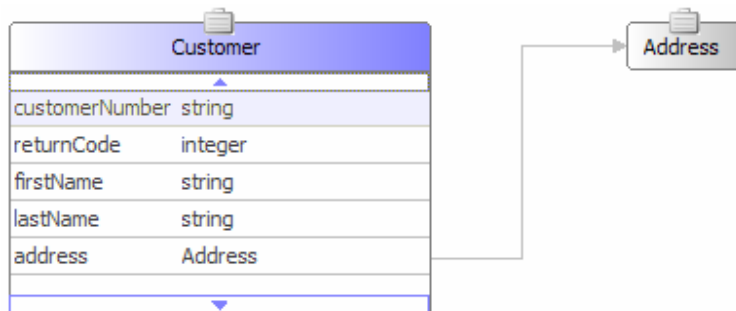

35

가 , ASBO(*Application Specific Business Object*)가  
 GBO(*Generic Business Object*)가  
 GBO ASBO . ASBO GBO  
 EIS 가 COBOL BPEL , CICS  
 ( 36).

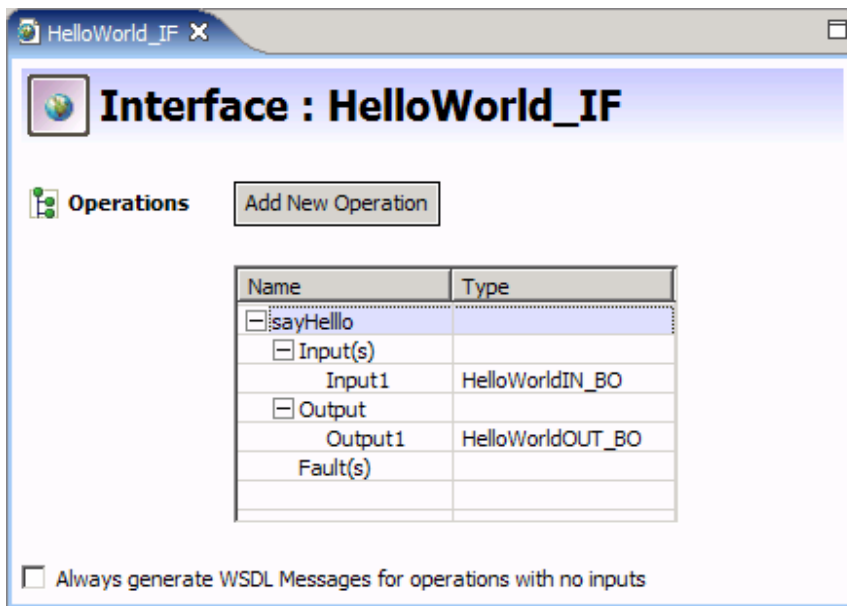

36

( 37).

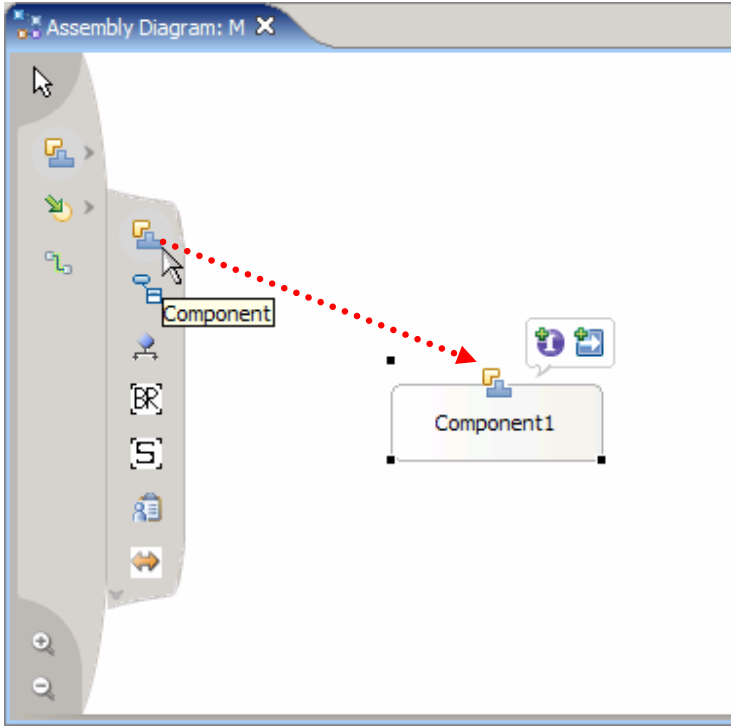

37

가

38)

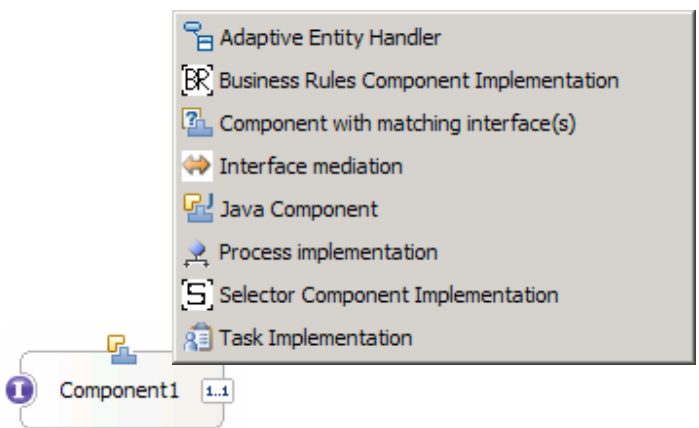

38

( 39).

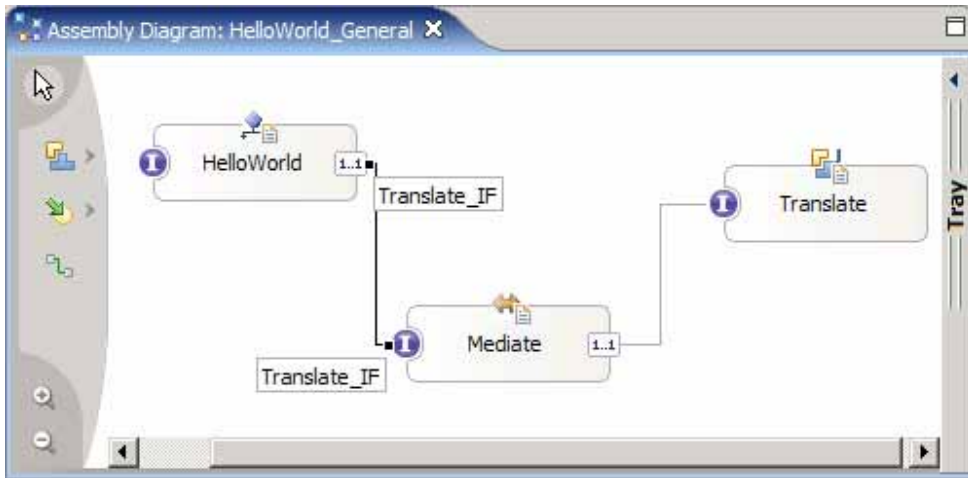

39

## EIS

EIS

(Enterprise Meta Data Discovery)

가 EIS

가

EIS

( 40).

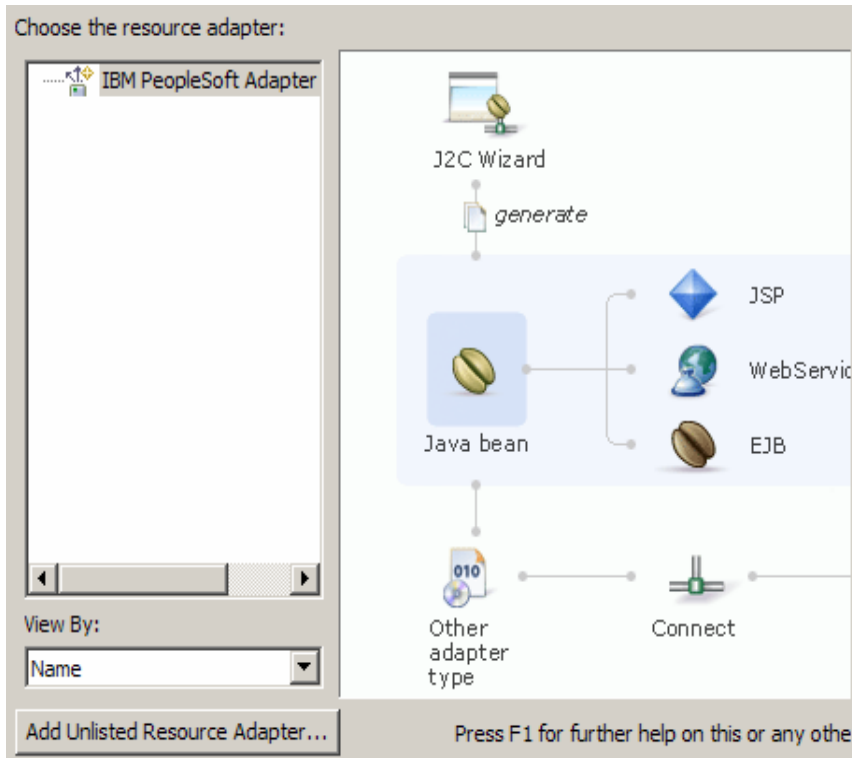

40

가

41

▼ Rules

Name	Rule1
Based on Template	Language Translation Cost
Web	If language is <a href="#">Click to set value</a> then translation rat

[Add If-Then Rule](#) +

▼ Templates

Name	Language Translation Cost		
Presentation	If language is <a href="#">\$lang</a> then translation rate is <a href="#">\$rate</a> per hour.		
Parameters	Name	Type	Constraint
	lang	String	
	rate	float	
if	input.language.equals ( "French" )		
then	output = 150		

41



가 ( : ).

42

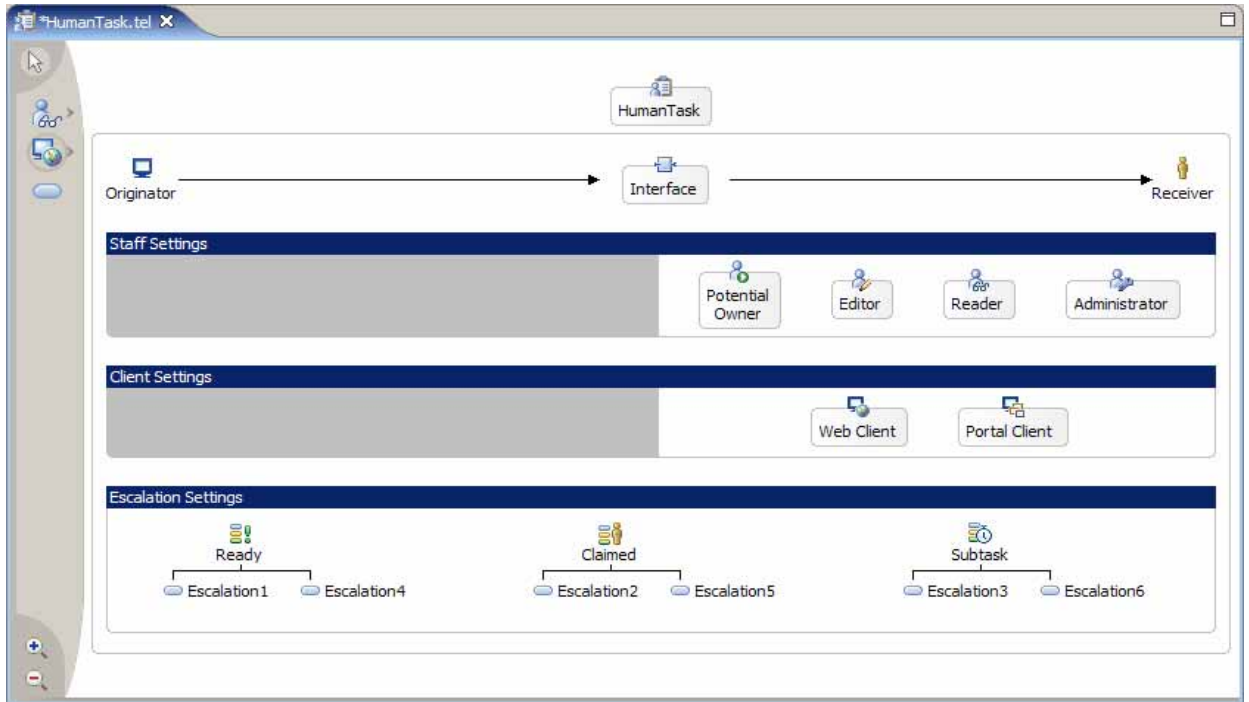

42

43

( )

가

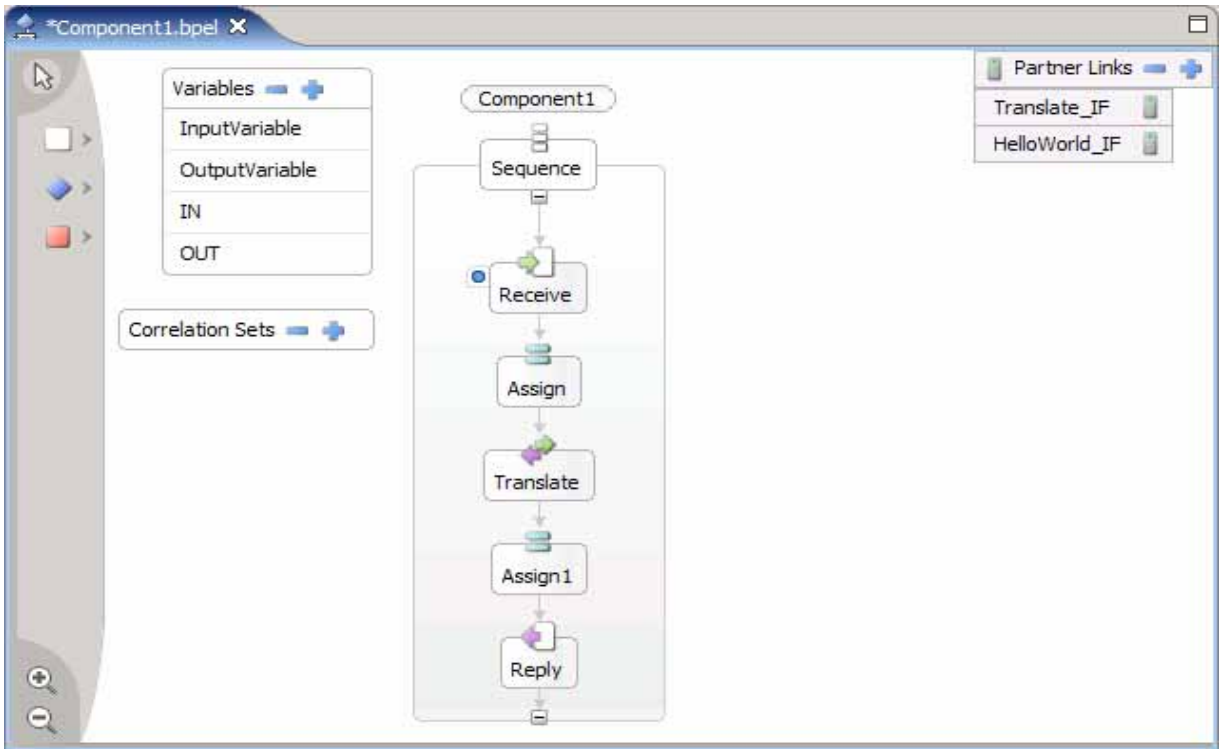

43

가 . 가 , ( 44).

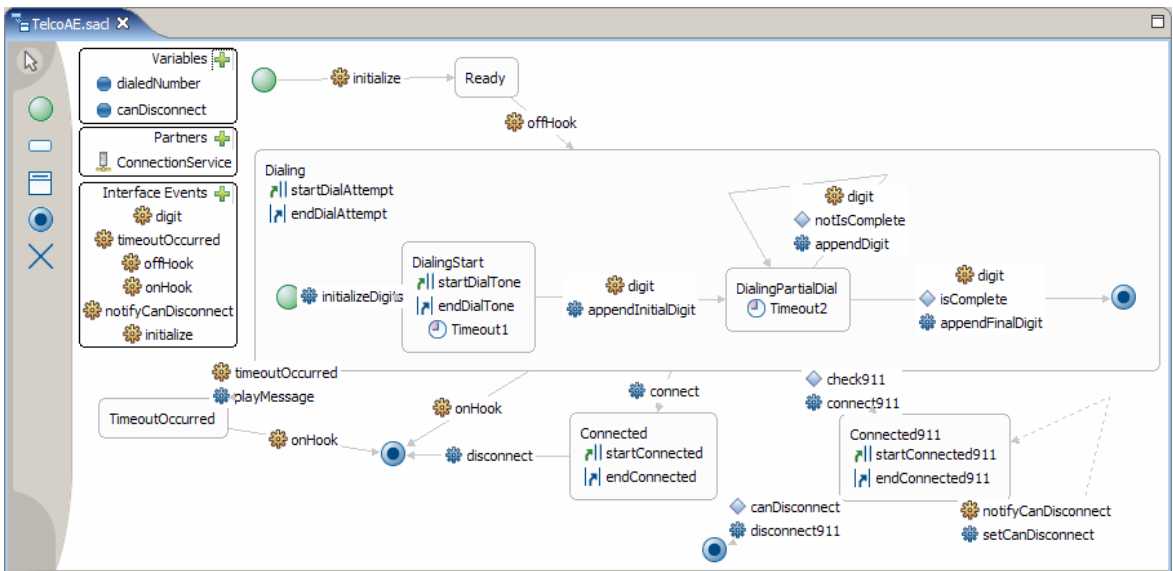

44

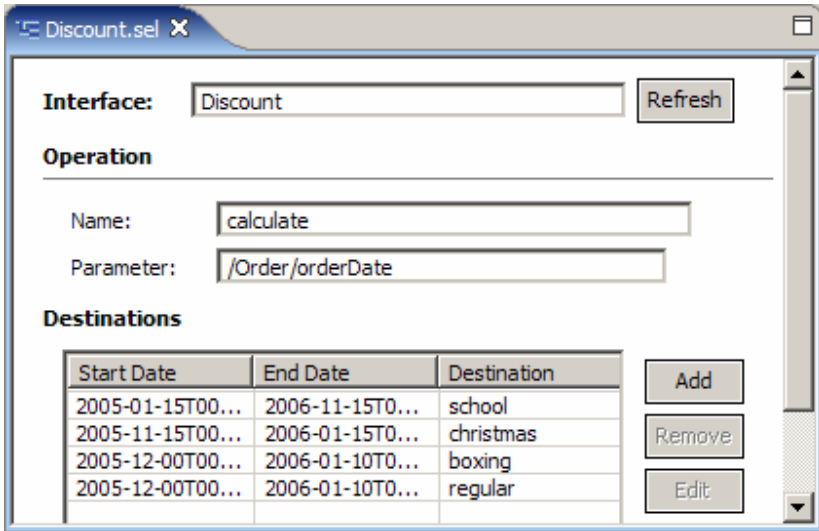

45

가 ( , 가 BPEL 가 Java 가 )

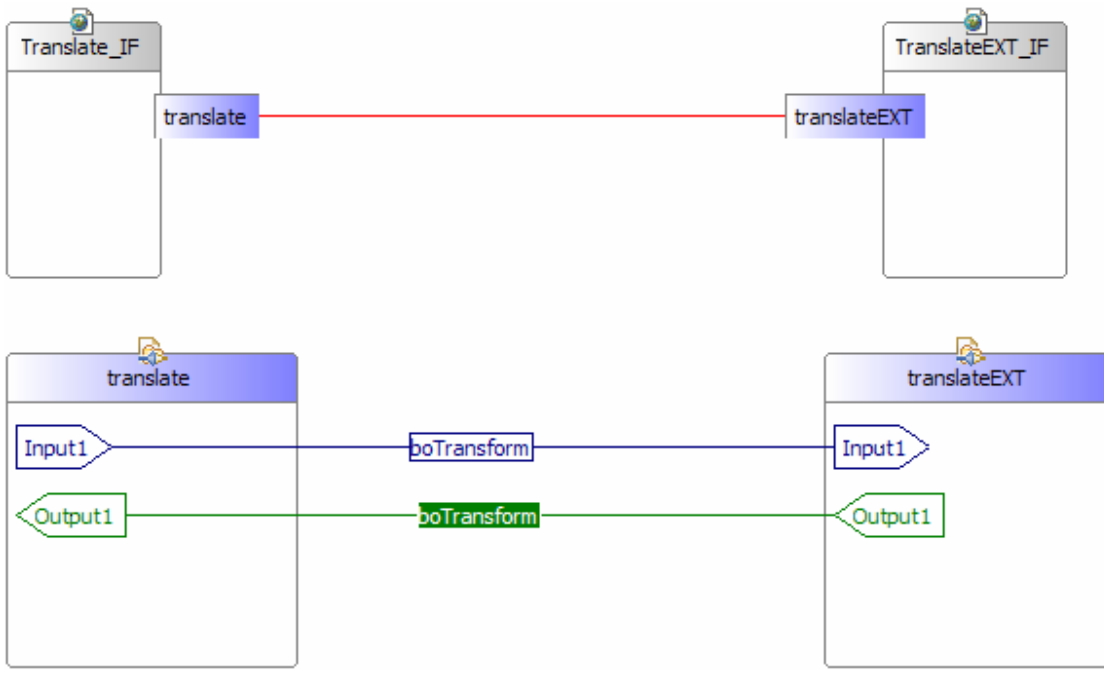

46

가  
( 47).

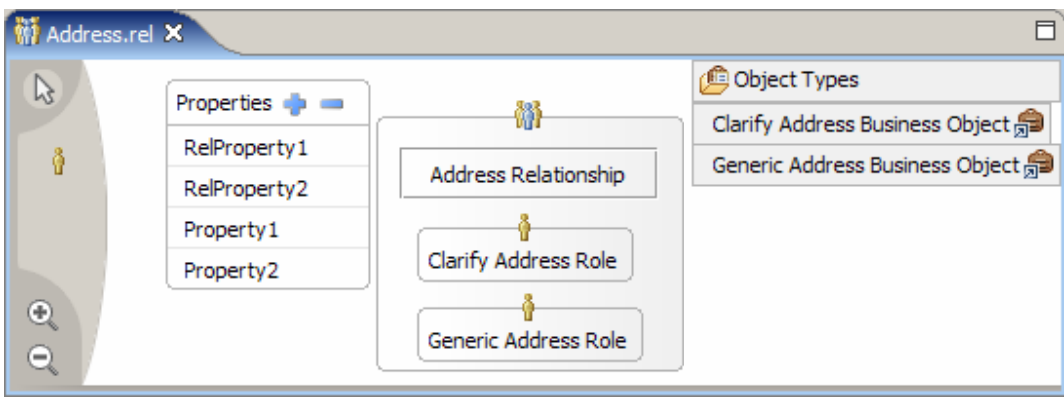

47

,

.

,

.

,

.

,

.

.

.

,

,

가

.

,

,

.

.