

Building a Better Infrastructure With IBM Middleware on System p

Consolidate Sprawling Web Tiers Onto
Scalable WebSphere Servers

Web Application Servers Need a Foundation

- The Java Virtual Machine (JVM) is the foundation for JEE application servers

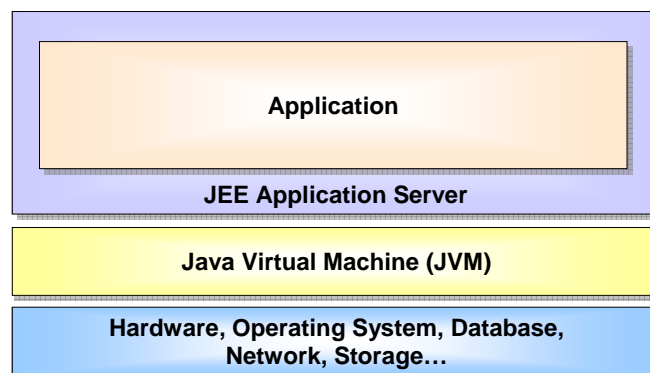

IBM SDK For Java Version 6 Provides Superior JVM Performance

- **Class instances can be shared across multiple JVMs**
 - ▶ Reduces memory requirements
 - ▶ Speeds startup
- **Garbage Collection (GC) process is enhanced**
 - ▶ Improved recognition of unused memory requires less frequent GC cycles
 - ▶ Parallel compaction threads increases efficiency of GC
- **Just in Time (JIT) compilation is highly effective**
 - ▶ Asynchronous threads for JIT compilation
 - ▶ Ordered queue for compilation makes sure most-used methods are compiled first
 - ▶ Five levels of optimization are offered for complete control
 - ▶ Methods can be re-compiled dynamically when runtime profile changes
 - ▶ Compiled methods can be cached across JVM instances, reducing JVM startup time

The Web Application Server is the Next Layer

- Provides a common environment and programming model for web applications
 - ▶ **Insulates** applications from hardware, operating system, network...
 - ▶ **Write once, run anywhere** (JEE™)
 - ▶ Provides a scalable **transaction** engine for your enterprise
 - ▶ Platform for developing and deploying **Web Services**

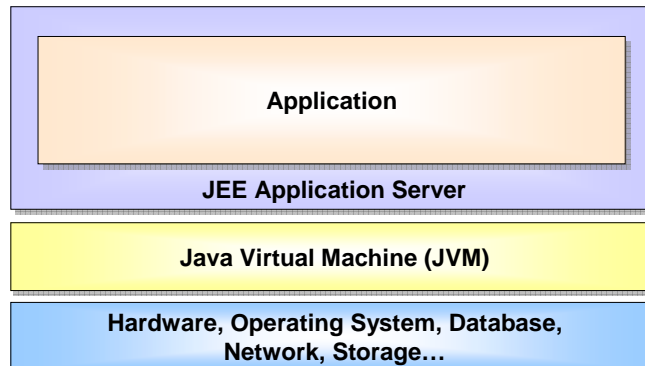

Why IBM WebSphere Software?

Nobody has the same breadth and depth

- Broad portfolio relied on by over 87,000 customers
- #1 market share
- Extensive ecosystem – more than 4,000 partners and 3,150 active ISV solutions
- Over 90% of the top Standard & Poor's 100 accounts rely on WebSphere Application Servers to run their business

Nobody invests more

- IBM investing over \$1B a year to deliver SOA and Web services capabilities
- Over 6,700 IBM developers
- Over 10,750 IGS technical practitioners trained on WebSphere

Award winning SOA products



IBM tops elite vendor list -Intelligent Enterprise Editors' Choice Awards (April 2005)



IBM Overall Winner in Application Integration Middleware
-CRN Channel Champions Award (March 2005)



WebSphere: "impressive management options, support for Web services and general ease of use..."
- Network Computing (February 2005)

IBM WebSphere Application Server Family

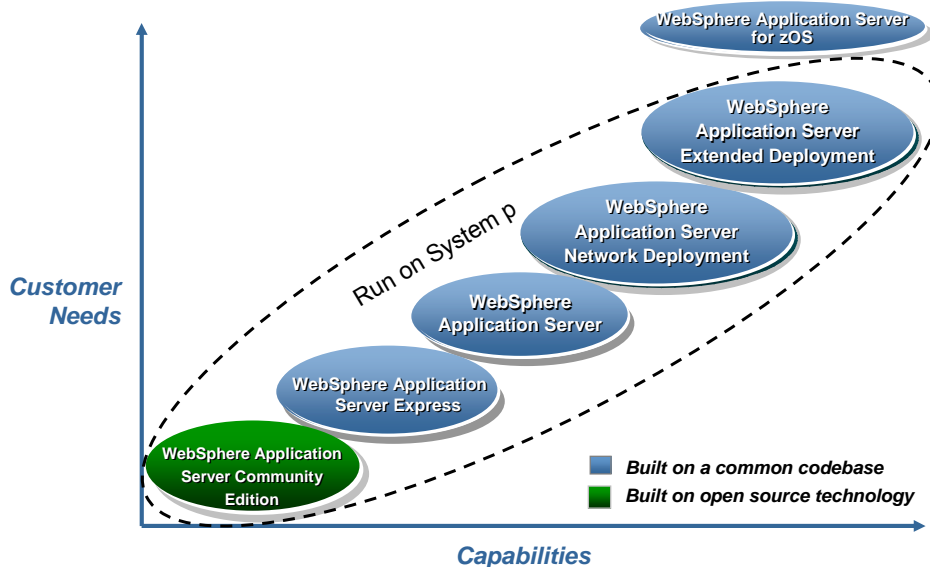

WebSphere Application Server 6.1 Exploits System p Hardware

- Supports 64-bit AIX and Linux on System p
 - ▶ Leverages large memory
 - caching large amounts of data in memory
 - avoiding slower access resources like databases or disks
 - BLOB's (binary large objects) is a good case, in 32-bit, sometimes not able to cache the entire object in the Java heap
 - ▶ Java heaps can be configured much larger than the ~2-3GB limitations of the 32-bit platforms to enhance performance
 - ▶ Double precision 64-bit mathematical computations are better for
 - computational intense applications
 - statistical applications, simulation and modeling applications
 - apps that use security and encryption

WebSphere Application Server Caching Improves Performance

- WebSphere Application Server supports caching of static content
 - ▶ HTML pages
 - ▶ Graphic files (e.g., JPG)
 - ▶ Java class libraries
- WebSphere Application Server also supports caching of dynamic content produced by
 - ▶ Java servlets
 - ▶ JavaServer Pages (JSP)
 - ▶ WebSphere command objects
 - ▶ Web services objects
 - ▶ Java objects
- What was the name given to IBM's patented dynamic caching technology?
 - ▶ "DynaCache"

WebSphere Dynamic Caching Increases Overall Throughput

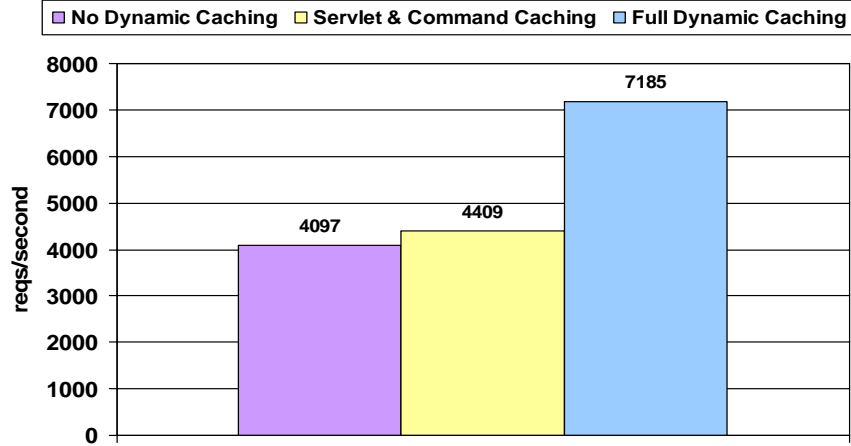

WebSphere Application Server V6.1

IBM System p5-550, (4) 64-bit 1.65GHz POWER5+ processors (SMT Enabled), 4GB RAM, AIX 5.3 ML3 (64 bit)

Throughput increases with dynamic caching in all scenarios

WebSphere Application Server on System p SMP Achieves Near-Linear Scalability

WAS Performance Scaling on AIX on System p

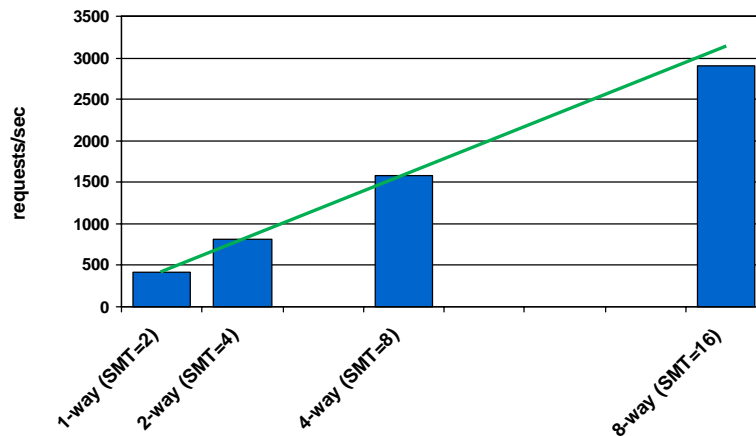

IBM p5-570, 16 x 1.9 GHz, 32GB RAM, AIX 5.3 SP2, 64 bit

Web Application Servers Are Often Clustered

■ Why?

- ▶ To increase workload capacity
- ▶ To improve availability

■ How?

- ▶ In multi-tier deployments
- ▶ Cluster members connected through LAN

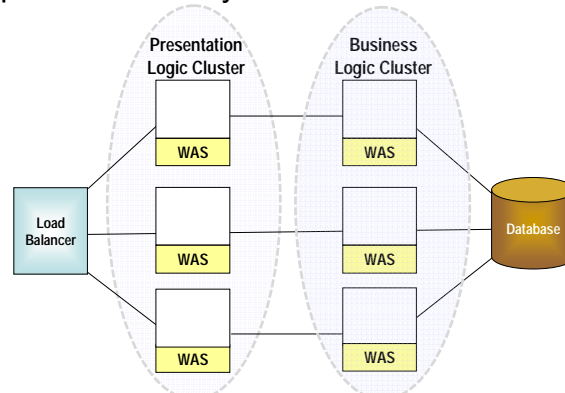

06 - Consolidate Sprawling Web Tiers 2008 v1.3r

13

WebSphere Network Deployment (ND) Provides Clustering Capability

- Built-in clustering capability eliminates single points of failure and also provides
 - ▶ Capacity to handle workloads greater than one server
 - ▶ Workload management to balance client requests across application servers
 - ▶ Server failover capability to automatically redirect requests to a redundant server
- Enables isolation of application servers. Each application server
 - ▶ Loads from local file system
 - ▶ Runs its own services (JNDI, security)
 - ▶ Logs distributed transactions
- Built-in High Availability Manager reduces the amount of time it takes to recover

06 - Consolidate Sprawling Web Tiers 2008 v1.3r

14

WAS ND Cluster Test: Perfect Failover and Recovery Behavior

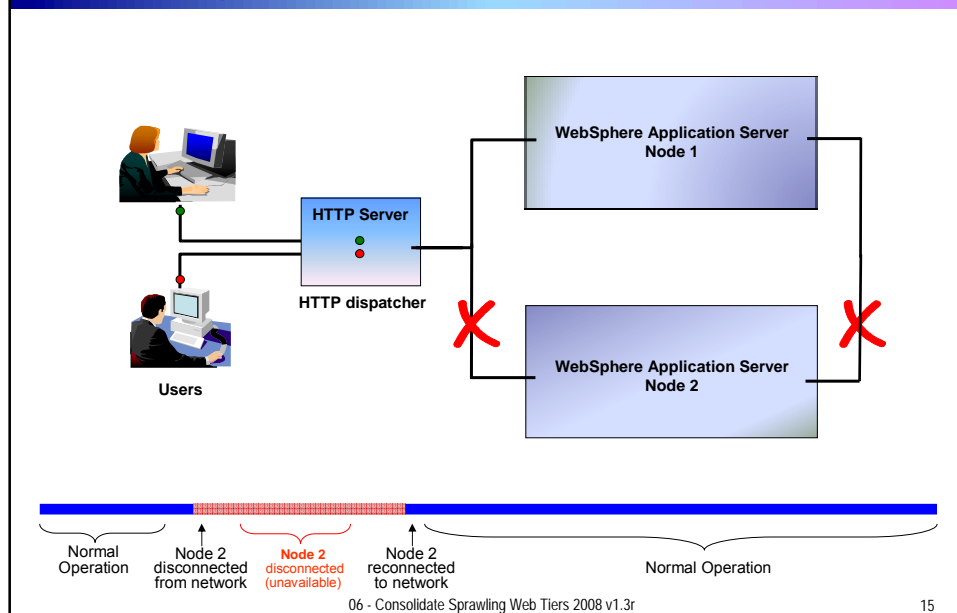

WebSphere XD Can Provide Continuous Operation – Even During Maintenance

- Application Edition Management
 - ▶ WebSphere XD supports managing multiple editions of an application in a WebSphere cluster
 - Explicit control over application editions (creation/activation/deletion)
- Interruption-free rollout of application updates
 - Explicit orchestration between routing agent and application servers during updates
 - ▶ Ability to “roll back” to a previous application version
- **Eliminate the need for planned web site outages!**

DEMO: WebSphere XD Application Update Rollout

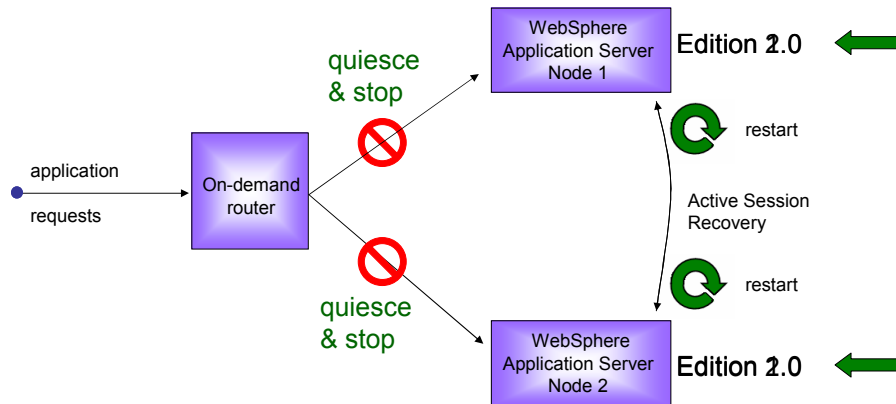

06 - Consolidate Sprawling Web Tiers 2008 v1.3r

17

WebSphere XD Is Designed for Data Centers with More Complex Requirements

- Continuous operations
 - ▶ Application update rollouts
- Dynamic cluster management
 - ▶ Pooled servers may be dynamically allocated to clusters to meet defined service levels
- Long-running Java workloads
 - ▶ “Batch-like” jobs
- Object Grid
 - ▶ Grid caching of objects for high-performance environments

06 - Consolidate Sprawling Web Tiers 2008 v1.3r

18

Wal*Mart Leverages WebSphere XD for Infrastructure Optimization and Availability

WAL*MART

- **Problem**
 - ▶ Under utilized, inefficient infrastructure (siloes)
 - ▶ Different administrative interfaces for the multitude of WebSphere applications
 - ▶ Peak demand for individual applications resulting in response time degradation
- **Solution**
 - ▶ Shared infrastructure based on WAS/ND and WAS/XD Operations Optimization
- **Key XD features / benefits**
 - ▶ Improved resource utilization / infrastructure optimization
 - Reclaim 90 servers while providing capacity for 50 future applications without additional hardware purchase
 - ▶ Increased system availability and reliability
 - ▶ Decreased support and administration time
 - ▶ Simplified rollouts via WAS/XD's application versioning capabilities

06 - Consolidate Sprawling Web Tiers 2008 v1.3r

19

Intel-based Web Environments, A Common Source of Server Sprawl

We have too many web application servers.



Service Oriented Finance
CIO

Let me show you how **WebSphere Application Server running on System p** can simplify your IT infrastructure.



IBM

06 - Consolidate Sprawling Web Tiers 2008 v1.3r

20

Scale Up From WebSphere Intel Clusters to System p

- Performance advantage on System p enables scale up
 - ▶ Replace Intel Servers with fewer System p servers
 - ▶ Simpler environment means less administration and a reduced footprint

- Can maintain hardware failover capabilities with server virtualization

- Virtual LAN enables communication between partitions at memory speed for additional performance advantages

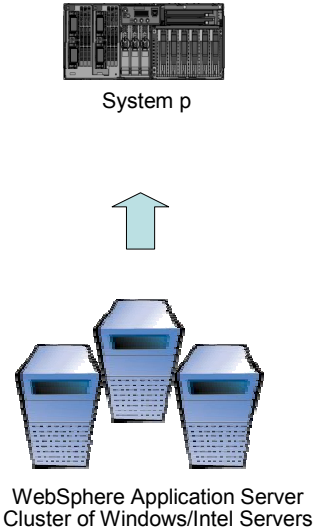

Scale Up and Consolidate to Simplify WebSphere Clusters

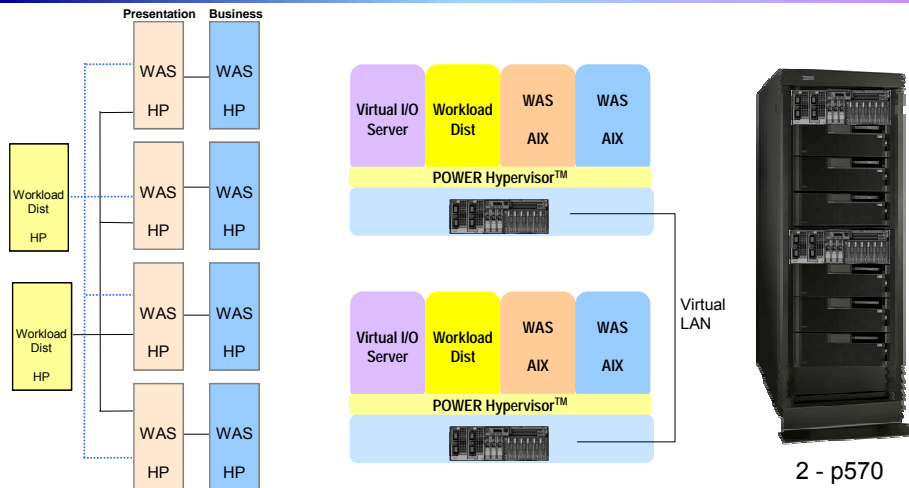

- Scale up leveraging performance advantages and server virtualization features
- Consolidate multiple types of workloads to a single System p
- Preserve advantages of clustering web application servers

How Can I Migrate to a WebSphere Environment on System p?

I want to move to WebSphere and System p to simplify my infrastructure!

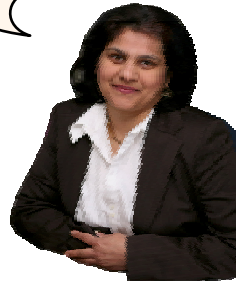

Service Oriented Finance
CIO

JEE applications can be easily migrated from other JEE servers.



IBM

Migrate JEE Web Applications to WebSphere on System p

Application portability – one of the key benefits of JEE architecture

Steps required:

1. Copy Enterprise Archive (EAR) file from other server
2. Install EAR into WebSphere Application Server
3. Specify environment-specific configuration
 - ▶ Data stores
 - ▶ Security controls
 - ▶ Network

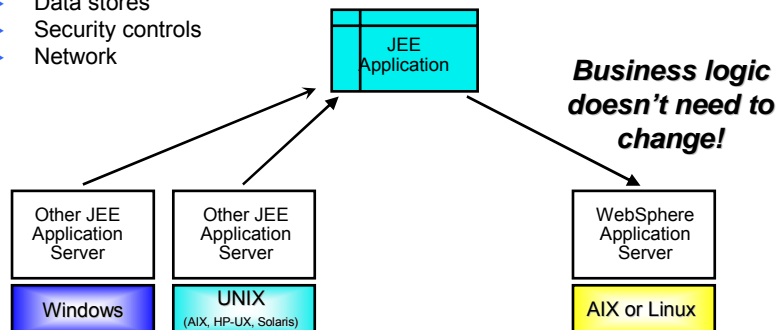

Execute .NET Code on System p

Visual MainWin® for Java EE

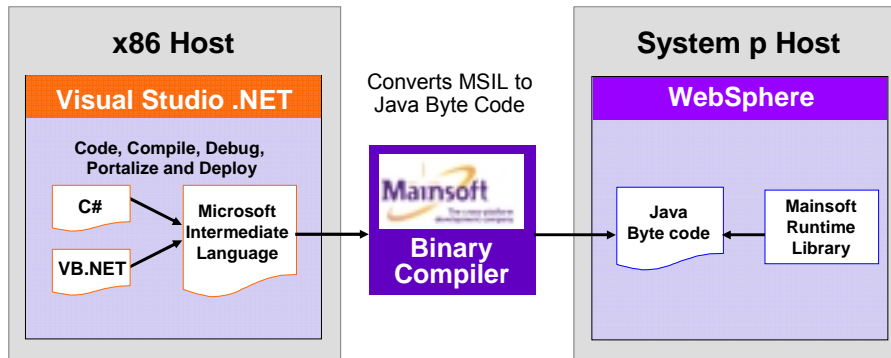

06 - Consolidate Sprawling Web Tiers 2008 v1.3r

25

WebSphere Application Server Consolidation Business Case

- Current environment
 - ▶ JEE application on WebSphere Application Server on Red Hat Linux
 - ▶ 30 HP Integrity rx2600 servers
 - 2 workload distributors
 - 14 presentation tier nodes
 - 14 business logic tier nodes
 - ▶ HP servers are used at 27% capacity

Annual Cost Per Unconsolidated Server*

Power and Cooling	\$731
Floor Space	\$987
Annual Server Maintenance	\$829
Annual Connectivity Maintenance	\$213
Annual Disk Maintenance	\$203
Annual Software support	\$3,263
Annual Enterprise Network	\$1,024
Annual Sys Admin	\$20,359
Total Annual Costs	\$27,609

For 30 unconsolidated servers, annual costs are
\$828,280

* Source: IBM internal consolidation project

06 - Consolidate Sprawling Web Tiers 2008 v1.3r

26

Consolidation Cost Summary and Comparison

System p One Time Charge

Server Acquisition	\$ 725,582
Connectivity Acquisition	\$ 38,322
Disk Acquisition	\$ 98,719
Software Licenses	\$ 80,699
Migration Cost	\$ 336,993
Total OTC (Cost of migration)	\$ 1,280,314

Price Sources—System p 570 and maintenance, Red Hat Linux and maintenance: IBM Technical Sales; WebSphere Application Server: IBM.com Passport Advantage Express Software Catalog; HP Integrity and maintenance: HP TPC-C benchmark report.

81% reduction in power consumption

97% reduction in floor space costs

System p Annual Cost

	Year 1	Year 2, 3
Power and Cooling	\$ 4,214	\$ 4,214
Space	\$ 1,125	\$ 1,125
Annual Server Maint	\$ 33,564	\$ 33,564
Annual Connectivity Maint	\$ 1,533	\$ 1,533
Annual Disk Storage Maint	\$ 3,949	\$ 3,949
Annual SW Support	\$ 1,499	\$ 17,339
Annual Ent. Network	\$ 13,824	\$ 13,824
Annual Sys Admin	\$ 82,889	\$ 82,889
Total Annual Costs	\$ 142,596	\$ 158,436

Unconsolidated Annual Cost

Power and Cooling	\$ 21,930
Space	\$ 29,610
Annual Server Maint	\$ 24,880
Annual Connectivity Maint	\$ 6,390
Annual Disk Storage Maint	\$ 6,090
Annual SW Support	\$ 97,890
Annual Ent. Network	\$ 30,720
Annual Sys Admin	\$ 610,770
Total Annual Costs	\$ 828,280

Operational cost savings = \$ 669,844 per year, break even in 23 months

06 - Consolidate Sprawling Web Tiers 2008 v1.3r

27

WebSphere Application Server Cash Flow Analysis

Savings Cash Flow When Consolidating 30 HP Servers to System p

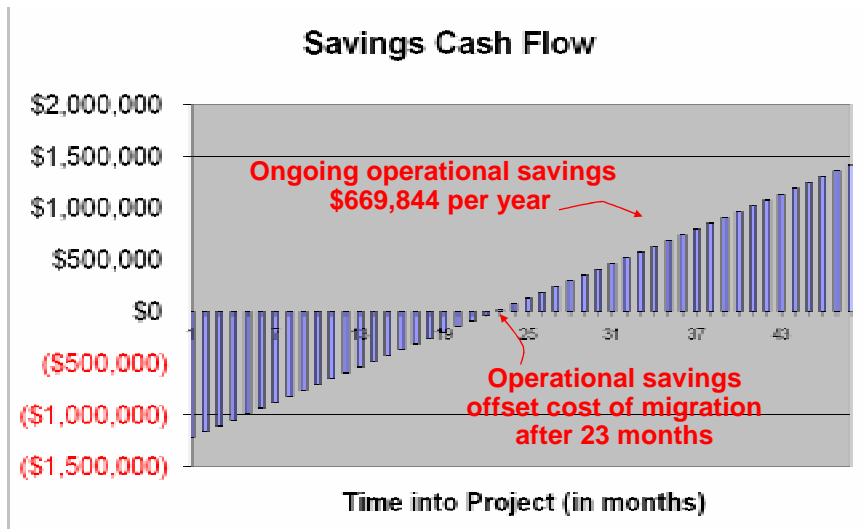

06 - Consolidate Sprawling Web Tiers 2008 v1.3r

28

Service Oriented Finance Consolidated Their Web Servers onto System p

You saved a lot of money by consolidating our servers



And simplified my environment!

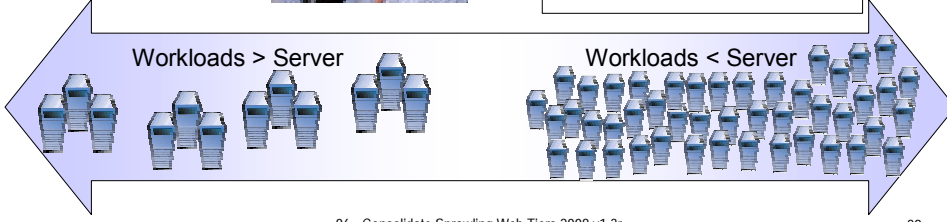
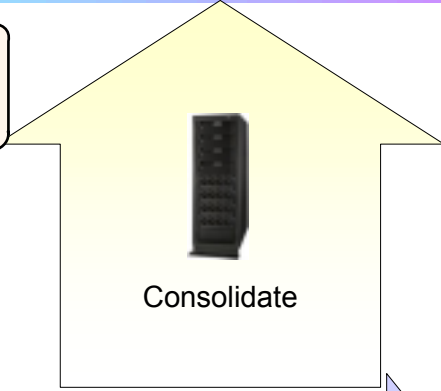

References, Additional Information

- MainSoft contact: Ron Johnsen – VP WW Sales,
ronj@mainsoft.com USA 408 200 4023
- WebSphere 64-bit performance whitepaper:
<ftp://ftp.software.ibm.com/software/webserver/appserv/was/64bitPerf.pdf>