

Compaq StorageWorks

HSG80 Array Controller ACS Version 8.5

Maintenance and Service Guide

Third Edition (February 2000)
Part Number: EK-HSG84-SV. C01
Compaq Computer Corporation

Notice

© 2000 Compaq Computer Corporation.
Printed in the U.S.A.

COMPAQ, Compaq logo, and StorageWorks Registered in U. S. Patent and Trademark Office. NonStop, SANswitch, and Tru64 are trademarks and/or service marks of Compaq Information Technologies Group, L.P.

Intel is a registered trademark of Intel Corporation in the United States and/or other countries. UNIX is a registered trademark of The Open Group.

Windows NT is a registered trademark of Microsoft Corporation in the United States and/or other countries.

All other product names mentioned herein may be trademarks or registered trademarks of their respective companies.

Compaq shall not be liable for technical or editorial errors or omissions contained herein. The information in this document is subject to change without notice.

The information in this publication is subject to change without notice and is provided "AS IS" WITHOUT WARRANTY OF ANY KIND. THE ENTIRE RISK ARISING OUT OF THE USE OF THIS INFORMATION REMAINS WITH RECIPIENT. IN NO EVENT SHALL COMPAQ BE LIABLE FOR ANY DIRECT, CONSEQUENTIAL, INCIDENTAL, SPECIAL, PUNITIVE OR OTHER DAMAGES WHATSOEVER (INCLUDING WITHOUT LIMITATION, DAMAGES FOR LOSS OF BUSINESS PROFITS, BUSINESS INTERRUPTION OR LOSS OF BUSINESS INFORMATION), EVEN IF COMPAQ HAS BEEN ADVISED OF THE POSSIBILITY OF SUCH DAMAGES.

The limited warranties for Compaq products are exclusively set forth in the documentation accompanying such products. Nothing herein should be construed as constituting a further or additional warranty.

Compaq StorageWorks HSG80 Array Controller ACS Version 8.5 Maintenance and Service Guide
Third Edition (February 2000)
Part Number: EK-HSG84-SV. C01

Contents

About This Guide

Intended Audience	xiii
How This Guide is Arranged	xiv
Getting Help	xv
Conventions	xv
Text Conventions	xv
Special Notices	xvi
Related Publications	xvii

Chapter 1

General Description

Subsystem Components — Exploded Views	1-1
HSG80 Subsystem in a BA370 Enclosure	1-2
HSG80 Subsystem in a Model 2200 Enclosure	1-4
BA370 Enclosure EMU	1-6
Model 2200 Enclosure Serial Port Cable	1-7
HSG80 Array Controller	1-8
Cache Module	1-10
Connectors, Switches, and LEDs	1-11
HSG80 Array Controller Front Panel	1-11
Array Controller OCP LEDs	1-12
GLM Connectors and Components	1-13
180 W Power Supply LEDs	1-14
BA370 Enclosure PVA Module Connector and Switches	1-15
BA370 Enclosure EMU Connectors, Switches, and LEDs	1-16

Model 2200 Enclosure EMU Switches and LEDs	1-17
Model 2200 Enclosure ECB LEDs	1-18
Model 2200 Enclosure Fan LEDs	1-19

Chapter 2

Common Replacement Information and Procedures

Required Tools	2-1
Precautions	2-2
Component Precaution	2-2
Electrostatic Discharge Precautions	2-2
Maintenance Port Precautions	2-3
Preparation Procedures	2-3
Establishing a Local Connection to the Controller	2-3
Fibre Channel Optical Cable Cleaning Instructions	2-5
Cleaning the GLM	2-6
Replacing a GLM	2-7
Removing a GLM	2-8
Installing a GLM	2-8
Replacing DIMMs	2-9
Removing DIMMs	2-10
Installing DIMMs	2-10
Replacing a Fiber Cable, Switch, or Hub	2-12
Remove a Fiber Cable, Switch, or Hub	2-12
Install a Fiber Cable, Switch, or Hub	2-13
Replacing a Program Card	2-14
Replacing a Failed StorageSet Member	2-15
Removing a Failed RAIDset or Mirrorset Member	2-16
Installing the New Member	2-16

Chapter 3

Replacement Procedures for BA370 Enclosure Elements

Shutting Down the Subsystem	3-1
Restarting the Subsystem	3-3
Replacing Controller and Cache Modules in a Single-Controller Configuration	3-4
Replacing a Controller and Cache Module in a Single-Controller Configuration	3-5
Replacing a Controller in a Single-Controller Configuration	3-5
Removing the Controller in a Single-Controller Configuration	3-5
Installing the Controller in a Single-Controller Configuration	3-7
Replacing a Cache Module in a Single-Controller Configuration	3-8
Removing the Cache Module in a Single-Controller Configuration	3-9
Installing the Cache Module in a Single-Controller Configuration	3-10

Replacing Controller and Cache Modules in a Dual-Redundant Controller Configuration . . .	3-11
Replacing a Controller and Cache Module in a Dual-Redundant Controller Configuration	3-12
Removing a Controller and Cache Module in a Dual-Redundant Controller Configuration	3-12
Installing a Controller and its Cache Module in a Dual-Redundant Controller Configuration	3-16
Replacing a Controller in a Dual-Redundant Controller Configuration	3-19
Removing a Controller in a Dual-Redundant Controller Configuration	3-19
Installing a Controller in a Dual-Redundant Controller Configuration	3-22
Replacing a Cache Module in a Dual-Redundant Controller Configuration	3-24
Removing a Cache Module in a Dual-Redundant Controller Configuration	3-24
Installing a Cache Module in a Dual-Redundant Controller Configuration	3-27
Replacing an ECB	3-31
Replacing an ECB With the BA370 Subsystem Powered On	3-31
Replacing an ECB With the BA370 Subsystem Powered Off	3-33
Replacing a PVA Module	3-35
Replacing an EMU	3-37
Removing an EMU	3-37
Installing an EMU	3-38
Replacing an I/O Module	3-39

Chapter 4

Replacement Procedures for Model 2200 Enclosure Elements

Shutting Down the Subsystem	4-1
Restarting the Subsystem	4-2
Replacing Controller and Cache Modules in a Single-Controller Configuration	4-3
Replacing a Controller and Cache Module in a Single-Controller Configuration	4-4
Replacing a Controller in a Single-Controller Configuration	4-4
Removing the Controller in a Single-Controller Configuration	4-4
Installing the Controller in a Single-Controller Configuration	4-6
Replacing a Cache Module in a Single-Controller Configuration	4-7
Removing the Cache Module in a Single-Controller Configuration	4-8
Installing the Cache Module in a Single-Controller Configuration	4-8
Replacing Controller and Cache Modules in a Dual-Redundant Controller Configuration . . .	4-10
Replacing a Controller and Cache Module in a Dual-Redundant Controller Configuration	4-11
Removing a Controller and Cache Module in a Dual-Redundant Controller Configuration	4-11
Installing a Controller and its Cache Module in a Dual-Redundant Controller Configuration	4-13

Replacing a Controller in a Dual-Redundant Controller Configuration	4-14
Removing a Controller in a Dual-Redundant Controller Configuration	4-14
Installing a Controller in a Dual-Redundant Controller Configuration	4-16
Replacing a Cache Module in a Dual-Redundant Controller Configuration	4-17
Removing a Cache Module in a Dual-Redundant Controller Configuration	4-17
Installing a Cache Module in a Dual-Redundant Controller Configuration	4-19
Replacing an ECB	4-20
Replacing an I/O Module	4-22

Chapter 5

Upgrading the Subsystem

Upgrading Controller Software	5-2
Installing a New Program Card	5-2
Downloading New Software	5-4
Using CLCP to Install, Delete, and List Software Patches	5-7
Installing a Software Patch	5-7
Deleting a Software Patch	5-8
Listing Software Patches	5-10
Upgrading Firmware on a Device	5-12
Upgrading to a Dual-Redundant Controller Configuration	5-15
Upgrading Cache Memory	5-19

Chapter 6

Troubleshooting Resources

Running the Controller Diagnostic Test	6-1
ECB Charging Diagnostics	6-2
Battery Hysteresis	6-2
Typical Installation Troubleshooting Checklist	6-3
Troubleshooting Table	6-5
Caching Techniques	6-12
Read Caching	6-12
Read-Ahead Caching	6-12
Write-Through Caching	6-13
Write-Back Caching	6-13
Fault-Tolerance for Write-Back Caching	6-13
Nonvolatile Memory	6-13
Cache Policies Resulting from Cache Module Failures	6-14
Enabling Mirrored Write-Back Cache	6-17

Significant Event Reporting	6-18
Events That Cause Controller Operation to Terminate	6-18
Flashing OCP Pattern Display Reporting	6-19
Solid OCP Pattern Display Reporting.	6-21
Last Failure Reporting.	6-25
Events That Allow Controller Operation to Continue	6-25
Spontaneous Event Log.	6-26
CLI Event Reporting	6-27
Utilities and Exercisers	6-27
FMU	6-27
Displaying Failure Entries.	6-28
Translating Event Codes	6-29
Controlling the Display of Significant Events and Failures	6-31
Using VTDPY to Check for Communication Problems	6-33
Checking Controller-to-Host Communications	6-34
Checking Controller-to-Device Communications.	6-37
Checking Device Type and Location.	6-38
Checking Device Status and I/O Activity	6-39
Checking Device-Port Status and I/O Activity	6-40
Checking Unit Status and I/O Activity	6-41
Checking Fibre Channel Link Errors	6-43
TACHYON Chip Status	6-47
Checking Runtime Status of Remote Copy Sets.	6-48
DILX.	6-50
Checking for Disk Drive Problems.	6-50
Finding a Disk Drive in the Subsystem	6-50
Testing the Read Capability of a Disk Drive	6-50
Testing the Read and Write Capabilities of a Disk Drive	6-51
DILX Error Codes.	6-54
HSUTIL	6-54
CONFIG Utility	6-55
CLCP Utility.	6-56
CLONE Utility	6-56
FRUTIL	6-56
CHVSN Utility.	6-57

Chapter 7

Event Reporting: Templates and Codes

Passthrough Device Reset Event Sense Data Response	7-1
Last Failure Event Sense Data Response (Template 01)	7-2
Multiple-Bus Failover Event Sense Data Response (Template 04).	7-4

Failover Event Sense Data Response (Template 05)	7-5
Nonvolatile Parameter Memory Component Event Sense Data Response (Template 11) . .	7-6
Backup Battery Failure Event Sense Data Response (Template 12)	7-8
Subsystem Built-In Self Test Failure Event Sense Data Response (Template 13)	7-9
Memory System Failure Event Sense Data Response (Template 14)	7-10
Device Services Non-Transfer Error Event Sense Data Response (Template 41)	7-12
Disk Transfer Error Event Sense Data Response (Template 51)	7-14
Data Replication Manager Services Event Sense Response (Template 90)	7-15
ASC/ASCQ Codes	7-17
Instance Codes	7-20
Instance Code Structure	7-20
Instance Codes and FMU	7-20
Notification/Recovery (NR) Threshold	7-21
Repair Action	7-21
Event Number	7-21
Component ID	7-22
Last Failure Codes	7-45
Last Failure Code Structure	7-45
Last Failure Codes and FMU	7-46
Hardware/Software (HW)	7-46
Restart Code	7-46
Parameter Count	7-46
Repair Action	7-47
Error Number	7-47
Component ID	7-47
Recommended Repair Action Codes	7-88
Component Identifier Codes	7-93

Appendix A

Array Controller Specifications

Physical and Electrical Specifications for the HSG80 Array Controller and Cache Modules . .	A-1
Environmental Specifications	A-2

Glossary

Index

Figures

Figure 1-1. HSG80 subsystem in a BA370 enclosure	1-2
Figure 1-2. HSG80 subsystem in a Model 2200 enclosure	1-4
Figure 1-3. BA370 enclosure EMU and its communication cable	1-6
Figure 1-4. Model 2200 enclosure UPS communication cable connection	1-7
Figure 1-5. HSG80 array controller—Fibre Channel optical cabling and program card	1-8
Figure 1-6. Cache module	1-10
Figure 1-7. HSG80 array controller front panel connectors, switches, and LEDs	1-11
Figure 1-8. Array controller OCP switches and LEDs	1-12
Figure 1-9. GLM connectors and components.	1-13
Figure 1-10. 180 W power supply LEDs.	1-14
Figure 1-11. BA370 enclosure PVA connector and switches	1-15
Figure 1-12. BA370 enclosure EMU connectors, switches, and LEDs.	1-16
Figure 1-13. Model 2200 enclosure EMU switches and LEDs	1-17
Figure 1-14. Model 2200 enclosure ECB LEDs	1-18
Figure 1-15. Model 2200 enclosure Fan LEDs	1-19
Figure 2-1. PC/terminal to maintenance port connection	2-4
Figure 2-2. Ferrule on an optical cable	2-5
Figure 2-3. Cleaning procedure for GLM	2-6
Figure 2-4. Location of GLMs inside a controller.	2-7
Figure 2-5. Cache module DIMM locations	2-9
Figure 2-6. DIMM components	2-11
Figure 2-7. Controller reset button and first three LEDs	2-12
Figure 2-8. Using pliers to disconnect an optical cable	2-13
Figure 2-9. Program (PCMCIA) card location and components	2-14
Figure 3-1. Controller reset button and first three LEDs	3-2

Figure 3-2. ECB battery disable switch location.	3-3
Figure 3-3. Single-controller configuration.	3-4
Figure 3-4. Using pliers to disconnect an optical cable.	3-6
Figure 3-5. Location of array controller reset and port #6 buttons on the OCP	3-8
Figure 3-6. Dual-redundant controller configuration	3-11
Figure 3-7. Dual ECB configuration	3-31
Figure 3-8. I/O module locations in a BA370 enclosure.	3-39
Figure 3-9. I/O module locations.	3-39
Figure 4-1. Controller reset button and first three LEDs.	4-2
Figure 4-2. Single-controller configuration.	4-3
Figure 4-3. Using pliers to disconnect an optical cable.	4-5
Figure 4-4. Location of array controller reset and port #6 buttons on the OCP	4-7
Figure 4-5. Dual-redundant controller configuration	4-10
Figure 4-6. ECB and cache module locations in a Model 2200 enclosure	4-20
Figure 4-7. Removing an ECB that supports cache module B in a Model 2200 enclosure	4-21
Figure 4-8. I/O module locations in a Model 2200 enclosure.	4-22
Figure 4-9. I/O module to SCSI bus numbering	4-23
Figure 5-1. Program (PCMCIA) card	5-2
Figure 5-2. Controller reset button and first three LEDs.	5-3
Figure 5-3. Location of write-protection switch	5-4
Figure 5-4. Upgrading device firmware (BA370 enclosure example)	5-12
Figure 5-5. Cache module DIMM locations	5-19
Figure 5-6. DIMM components.	5-21
Figure 6-1. Sample of transfer (Xfer) rate region of the default display.	6-34
Figure 6-2. Sample of regions on the device display	6-38
Figure 6-3. Sample unit status on the cache display	6-41
Figure 6-4. Sample Fibre Channel host status display	6-44
Figure 6-5. Sample runtime status in the remote display (ACS V8.5P only)	6-48
Figure 7-1. Structure of an instance code	7-20
Figure 7-2. Structure of a last failure code	7-45

Tables

Table 1-1 HSG80 Subsystem in a BA370 Enclosure	1-3
Table 1-2 HSG80 Subsystem in a Model 2200 Enclosure.	1-5
Table 1-3 BA370 Enclosure EMU.	1-6
Table 1-4 Model 2200 Enclosure UPS Communication Cable	1-7
Table 1-5 HSG80 Fibre Channel Array Controller	1-9
Table 1-6 Cache Module	1-10
Table 1-7 HSG80 Array Controller Front Panel Connectors, Switches, and LEDs	1-12
Table 1-8 OCP Switches and LEDs.	1-12
Table 1-9 GLM Connectors and Components.	1-13
Table 1-10 180 W Power Supply LEDs.	1-14
Table 1-11 BA370 Enclosure PVA Connectors and Switches	1-15
Table 1-12 BA370 Enclosure EMU Connectors, Switches, and LEDs.	1-16
Table 1-13 Model 2200 Enclosure EMU Switches and LEDs	1-17
Table 1-14 Model 2200 Enclosure ECB LEDs	1-18
Table 1-15 Model 2200 Enclosure Fan LEDs	1-19
Table 2-1 Cache Module Memory Configurations	2-9
Table 5-1 Cache Module Memory Configurations	5-19
Table 6-1 Troubleshooting Table.	6-5
Table 6-2 Cache Policies—Cache Module Status	6-14
Table 6-3 Resulting Cache Policies—ECB Status.	6-16
Table 6-4 FLASHING OCP Patterns	6-19
Table 6-5 Solid OCP Patterns	6-21
Table 6-6 Event-Code Types	6-30
Table 6-7 FMU SET Commands	6-31
Table 6-8 VTDPY Key Sequences and Commands	6-33

Table 6-9	VTDPY Default Display Columns	6-35
Table 6-10	Device Map Columns	6-39
Table 6-11	Device Status Columns	6-39
Table 6-12	Device-Port Status Columns	6-40
Table 6-13	Unit Status Columns	6-41
Table 6-14	Fibre Channel Host Status Display — Known Hosts (Connections)	6-44
Table 6-15	Fibre Channel Host Status Display — Port Status	6-45
Table 6-16	Fibre Channel Host Status Display — Link Error Counters.	6-45
Table 6-17	First Digit on the TACHYON Chip	6-47
Table 6-18	Second Digit on the TACHYON Chip	6-47
Table 6-19	Remote Display Columns—ACS V8.5P only	6-48
Table 6-20	DILX Control Sequences	6-51
Table 6-21	Data Patterns for Phase 1: Write Test	6-52
Table 6-22	DILX Error Codes.	6-54
Table 6-23	HSUTIL Messages and Inquiries	6-54
Table 7-1	Passthrough Device Reset Event Sense Data Response Format.	7-2
Table 7-2	Template 01—Last Failure Event Sense Data Response Format	7-3
Table 7-3	Template 04—Multiple-Bus Failover Event Sense Data Response Format	7-4
Table 7-4	Template 05—Failover Event Sense Data Response Format	7-5
Table 7-5	Template 11—Nonvolatile Parameter Memory Component Event Sense Data Response Format	7-7
Table 7-6	Template 12—Backup Battery Failure Event Sense Data Response Format	7-8
Table 7-7	Template 13—Subsystem Built-In Self Test Failure Event Sense Data Response Format	7-9
Table 7-8	Template 14—Memory System Failure Event Sense Data Response Format	7-11
Table 7-9	Template 41—Device Services Non-Transfer Error Event Sense Data Response Format	7-13
Table 7-10	Template 51—Disk Transfer Error Event Sense Data Response Format.	7-14
Table 7-11	Template 90—Data Replication Manager Services Event Sense Data Response Format (ACS V8.5P only)	7-15
Table 7-12	ASC and ASCQ Codes	7-17
Table 7-13	Instance Code Format	7-20
Table 7-14	Event Notification/Recovery Threshold Classifications.	7-21
Table 7-15	Instance Codes	7-22
Table 7-16	Last Failure Code Format	7-46
Table 7-17	Controller Restart Codes	7-46
Table 7-18	Last Failure Codes.	7-47
Table 7-19	Recommended Repair Action Codes	7-88
Table 7-20	Component Identifier Codes	7-93
Table A-1	Controller Specifications	A-1
Table A-2	Operating Environmental Specifications	A-2
Table A-3	Nonoperating Environmental Specifications	A-2

About This Guide

This guide describes the features and part numbers of the HSG80 array controller running array controller software (ACS) version 8.5F, 8.5S, and 8.5P. It also contains replacement procedures, subsystem upgrade procedures, and troubleshooting resources which includes event reporting codes.

This guide does not contain information about the operating environments to which the controller might be connected, nor does it contain detailed information about subsystem enclosures or their components. See the documentation that accompanied these peripherals for information about them.

Intended Audience

This publication is for use by *Compaq*[™] *StorageWorks*[™] DS-BA370-Series UltraSCSI RAID enclosures and Model 2200-Series UltraSCSI controller enclosure customers and employees who are responsible for maintaining the enclosures.

How This Guide is Arranged

This manual discusses the enclosure and its major elements. The manual is organized as follows:

Chapter 1, “General Description”

Describes the subsystem components for the BA370 enclosure and Model 2200-series enclosure. Also describes the connectors, switches, and LEDs for various elements. *Compaq* and *DIGITAL* part numbers are listed for the various elements.

Chapter 2, “Common Replacement Information and Procedures”

Describes preliminary information, replacement and cleaning procedures that apply to both the BA370 enclosure and the Model 2200-series enclosure.

Chapter 3, “Replacement Procedures for BA370 Enclosure Elements”

Describes element replacement procedures that are specific to the BA370 enclosure.

Chapter 4, “Replacement Procedures for Model 2200 Enclosure Elements”

Describes element replacement procedures that are specific to the Model 2200 enclosure.

Chapter 5, “Upgrading the Subsystem”

Describes procedures that upgrade BA370 enclosure or Model 2200 enclosure functionality through either hardware or firmware improvements.

Chapter 6, “Troubleshooting Resources”

Provides guidelines for troubleshooting the HSG80 array controller, cache module, and external cache battery (ECB). Utilities and exercisers are also addressed which might benefit the troubleshooting process.

Chapter 7, “Event Reporting: Templates and Codes”

Describes the event codes that the fault management software provides for spontaneous events and last failure events.

Appendix A, “Array Controller Specifications”

Provides physical, electrical, and environmental specifications for the HSG80 array controller. Also, physical and electrical specifications for the cache module.

Glossary

Index

Getting Help

After exhausting the information in this guide, obtain further information and help using the *Compaq* website at <http://www.compaq.com/products/storageworks>. The website maintains information on this product as well as the latest drivers and Flash ROM images. The website also contains worldwide *Compaq* technical support phone numbers.

Conventions

This guide uses the text conventions in Table 1 and special notices provided within this section.

Text Conventions

Table 1 Text Conventions	
Convention	Meaning
Bold	Keyboard keys appear in boldface. For example: Enter/Return or Y(es) key
SMALL CAPS	Used to indicate the status of an LED. For example: FLASHING on and off or ON steady
ALLCAPS	Command syntax that must be entered exactly as shown and for commands discussed within text, for example: SET FAILOVER COPY=OTHER_CONTROLLER “Use the SHOW SPARESET command to show the contents of the spareset.”
Monospaced	Screen display.

Table 1 Text Conventions (Continued)	
Convention	Meaning
	User entered command variable or numeric value, for example: SHOW <i>RAIDset-name</i> or set this_controller id=(<i>n,n,n,n</i>)
<i>italic</i>	Identifies <i>Compaq</i> -specific trademarks or service marks used in this document, for example: <i>Compaq</i> , <i>StorageWorks</i> , and <i>Tru64</i> .
	Reference to other publications, for example: "See the <i>HSG80 Array Controller ACS Version 8.5 Release Notes</i> for details."
	Adds emphasis to text, for example: " <i>Do not</i> use the following command...."
.	Indicates that a portion of an example or figure has been omitted.
"this controller"	The controller serving the current CLI session through a local or remote terminal.
"other controller"	The controller in a dual-redundant pair that is connected to the controller serving the current CLI session.

Special Notices

This guide does not contain detailed descriptions of standard safety procedures. However, it does contain warnings for procedures that might cause personal injury and cautions for procedures that might damage the controller or its related components. Look for these symbols when performing the procedures in this guide:



WARNING: A warning indicates the presence of a hazard that can cause personal injury if precautions in the text are not observed.



CAUTION: A caution indicates the presence of a hazard that might damage hardware, corrupt software, or cause a loss of data.

IMPORTANT: An *important* note is a type of note that provides information essential to the completion of a task. Users can disregard information in a note and still complete a task, but they should not disregard an important note.

NOTE: A note provides additional information that is related to the completion of an instruction or procedure.

Related Publications

Table 2 lists documents related to the use of the controller, cache module, and external cache battery.

Table 2 Related Publications	
Document Title	Part Number
<i>Compaq StorageWorks RA8000/ESA12000 HSG80 Array Controller StorageWorks Solutions Software Kit Overview</i>	EK-SOLSR-AA / 166314-001
<i>Compaq StorageWorks HSG80 Array Controller ACS Version 8.5 Configuration Guide</i>	EK-HSG85-CG / 165144-001
<i>Compaq StorageWorks HSG80 Array Controller ACS Version 8.5 CLI Reference Guide</i>	EK-HSG85-RG / 165145-001
<i>Compaq StorageWorks Command Console V2.2 for RAID Array 8000/ESA12000 User's Guide</i>	AA-RFA2D-TE / 387405-004
<i>Compaq StorageWorks UltraSCSI RAID Enclosure (BA370-Series) User Guide</i>	EK-BA370-UG / 387403-001
<i>Compaq StorageWorks Model 2200-Series UltraSCSI Controller Enclosure User Guide</i>	EK-SE2C8-Ux ¹ / 127422- <i>nnn</i> ¹
<i>Compaq StorageWorks Fibre Channel Storage Switch Service Guide</i>	AA-RHBZA-TE / 135268-001
<i>Compaq StorageWorks Fibre Channel Storage Switch User Guide</i>	AA-RHBYA-TE / 135267-001
<i>Compaq StorageWorks Fibre Channel Switch Quick Setup Guide</i>	AA-RHC0A-TE / 135269-001
<i>Compaq StorageWorks Fibre Channel Arbitrated Loop Hub (DS-DHGGA-CA) User Guide</i>	EK-DHGGA-UG
<i>Compaq StorageWorks KGPSA PCI-to-Fibre Channel Host Adapter</i>	EK-KGPSA-UG

1. This document is localized. The “x” or “*nnn*” represents the specific localized version of this document.

Chapter 1

General Description

This chapter illustrates and describes, in general terms, the BA370 enclosure and Model 2200 enclosure subsystems and their major components, plus connectors, switches, and LEDs.

See the Fibre Channel Switch Documentation that came with the switch kit for specifics about how the switch operates. See the *KGPSA PCI-to-Fibre Channel Host Adapter User Guide* for information about the adapter that connects the subsystem to the host.

Subsystem Components — Exploded Views

This section illustrates the various subsystem components and specific attributes of each component. *Compaq* and DIGITAL classic spare part numbers are included as a convenience.

HSG80 Subsystem in a BA370 Enclosure

Figure 1-1 and Table 1-1 identify an HSG80 subsystem with a BA370 enclosure.

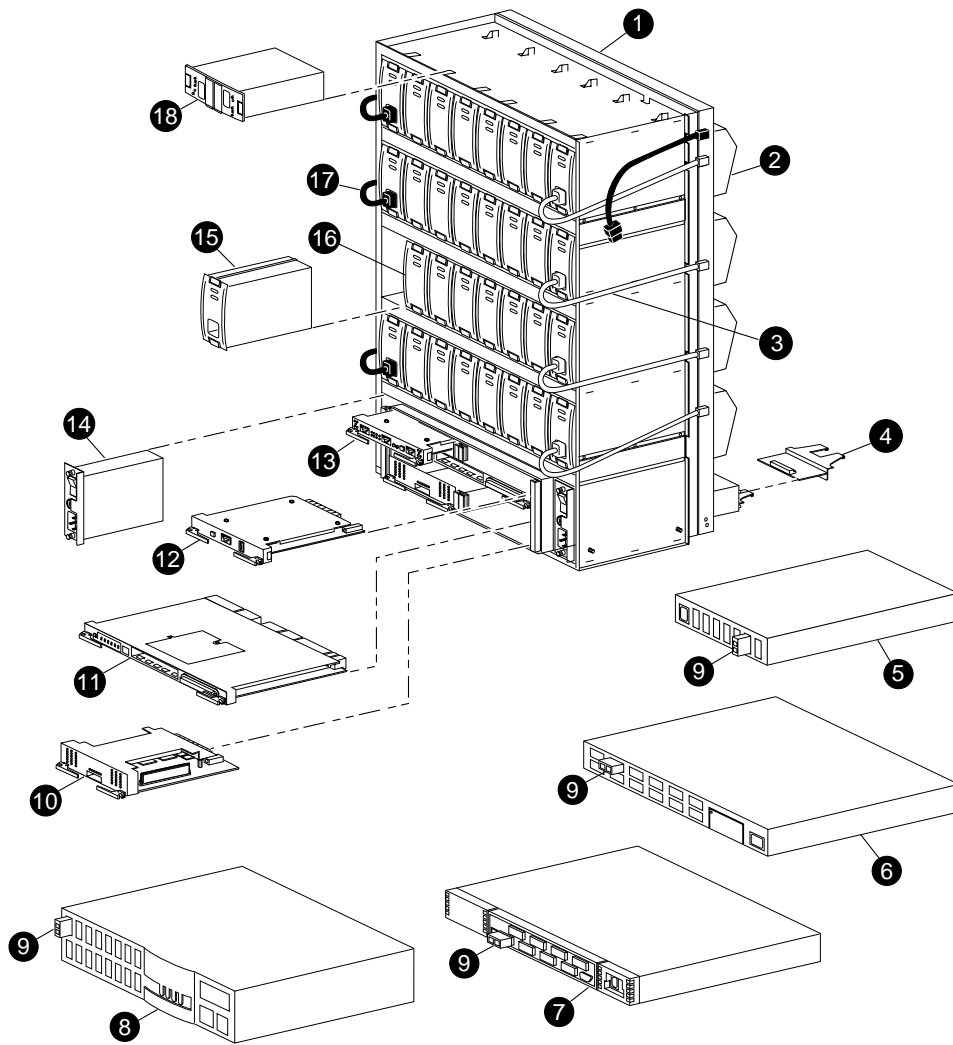

CX07180A

Figure 1-1. HSG80 subsystem in a BA370 enclosure

Table 1-1 HSG80 Subsystem in a BA370 Enclosure

Item	Description	Compaq Part Number	DIGITAL Part Number
①	BA370 rack-mountable enclosure	401914-001	DS-BA370-MA
②	Cooling fan, blue	400293-001	FC-BA35X-MK
	Cooling fan, gray	402602-001	FC-BA35X-ML
③	Power cable kit, white	401916-001	17-03718-10
④	Input/output (I/O) module, blue	400294-001	FC-BA35X-MN
	I/O module, gray	401911-001	70-32856-S2
⑤	Fibre Channel hub, 7-port	234454-001	FE-09061-01
⑥	Fibre Channel hub, 12-port	340858-001	30-50549-01
⑦	Fibre Channel switch, 8-port	127660-001	30-56042-S1
	Fibre Channel <i>SANswitch</i> TM , 8-port	167649-001	30-56132-S1
⑧	Fibre Channel switch, 16-port	127660-002	30-56042-S2
	Fibre Channel <i>SANswitch</i> , 16-port	167650-001	30-56132-S2
⑨	Gigabit interface converter (GBIC)	234458-001	FE-09086-01
⑩	Cache module (original)	400295-001	70-33256-S1
	Cache module (upgraded)	400295-002	70-33256-S2
⑪	HSG80 controller	400285-001	70-33259-S1
⑫	Power verification and addressing (PVA) module — with uninterruptable power supply (UPS) support	155057-003	70-33253-S3
⑬	Environmental monitoring unit (EMU)	400286-001	FC-BA35X-EB
⑭	AC input box	400287-001	FC-BA35X-HE
⑮	180-watt power supply	400288-001	FC-BA35X-HH
⑯	Disk drive, 4 GB, 7200 rpm	402153-001	FC-RZ1CF-VW
	Disk drive, 9 GB, 7200 rpm	400289-001	FC-RZ1DF-VW
	Disk drive, 18 GB, 7200 rpm	400290-001	FC-RZ1EF-VW
	Disk drive, 36 GB, 7200 rpm	147599-001	DS-RZ1FB-VW
	Disk drive, 9 GB, 10K rpm	402154-001	FC-RZ1DD-VW
	Disk drive, 18 GB, 10K rpm	402229-001	FC-RZ1ED-VW
⑰	Power cable, black	401915-001	17-03718-09
⑱	External cache battery (ECB), dual (shown)	400291-001	FC-HS35X-BD
	ECB, single (not shown)	400292-001	FC-HS35X-BC

HSG80 Subsystem in a Model 2200 Enclosure

Figure 1-2 and Table 1-2 identify an HSG80 subsystem with a Model 2200 enclosure.

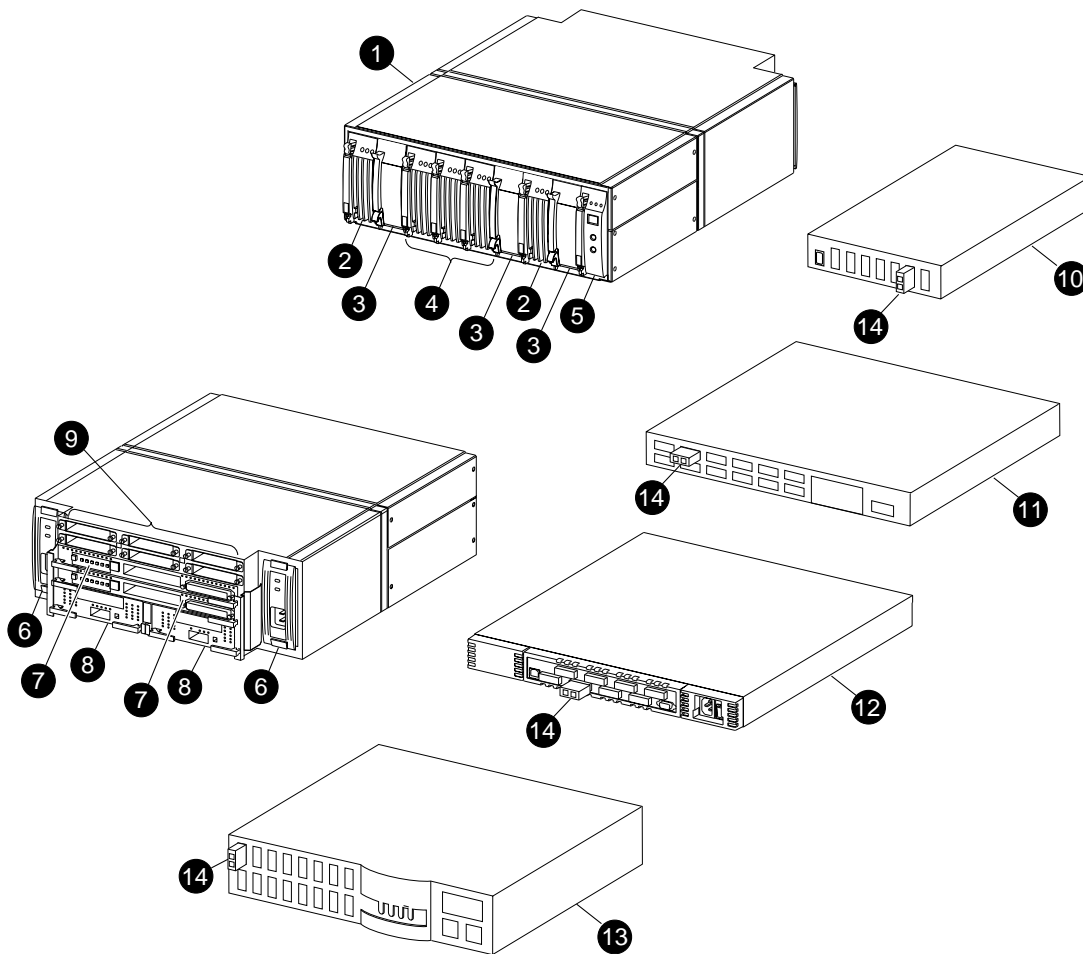

CXO7176A

Figure 1-2. HSG80 subsystem in a Model 2200 enclosure

Table 1-2 HSG80 Subsystem in a Model 2200 Enclosure

Item	Description	Compaq Part Number	DIGITAL Part Number
①	Model 2200 rack-mountable enclosure	126314-001	70-33725-S1
②	ECB without a battery pack	126312-001	70-33547-S1
	ECB battery pack	147514-001	12-44670-S4
③	Blank bezel	173406-001	74-60460-01
④	Fan	126310-001	70-33538-S1
⑤	EMU	126415-001	70-40081-S1
⑥	180 W Power supply	400288-001	FC-BA35X-HH
⑦	HSG80 controller	400285-001	70-33259-S1
⑧	Cache module	400295-002	70-33256-S2
⑨	I/O module	126313-001	70-33724-S1
⑩	Fibre Channel hub, 7-port	234454-001	FE-09061-01
⑪	Fibre Channel hub, 12-port	340858-001	30-50549-01
⑫	Fibre Channel switch, 8-port	127660-001	30-56042-S1
	Fibre Channel <i>SANswitch</i> , 8-port	167649-001	30-56132-S1
⑬	Fibre Channel switch, 16-port	127660-002	30-56042-S2
	Fibre Channel <i>SANswitch</i> , 16-port	167650-001	30-56132-S2
⑭	GBIC	234458-001	FE-09086-01

BA370 Enclosure EMU

Figure 1-3 and Table 1-3 identify the EMU and its communication cable for a BA370 enclosure.

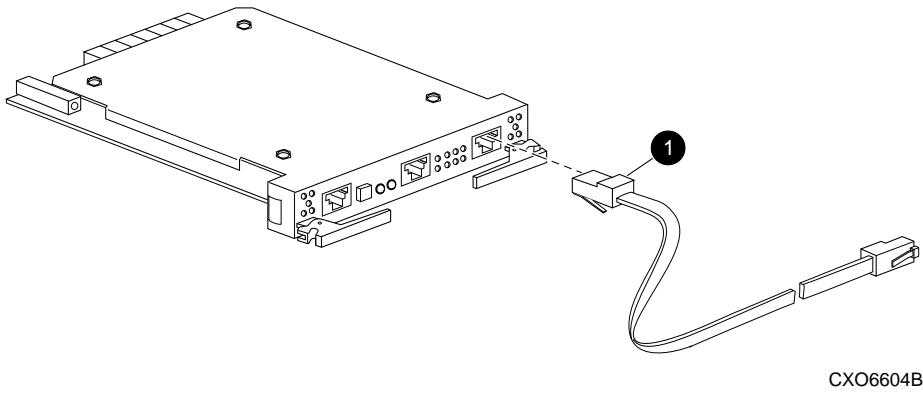

Figure 1-3. BA370 enclosure EMU and its communication cable

Table 1-3 BA370 Enclosure EMU

Item	Description	Compaq Part Number	DIGITAL Part Number
1	EMU-EMU communication cable, 4 meter	401949-001	17-03194-04

Model 2200 Enclosure Serial Port Cable

Figure 1-4 and Table 1-4 identify the communication cable that connects to the serial port on a Model 2200 enclosure.

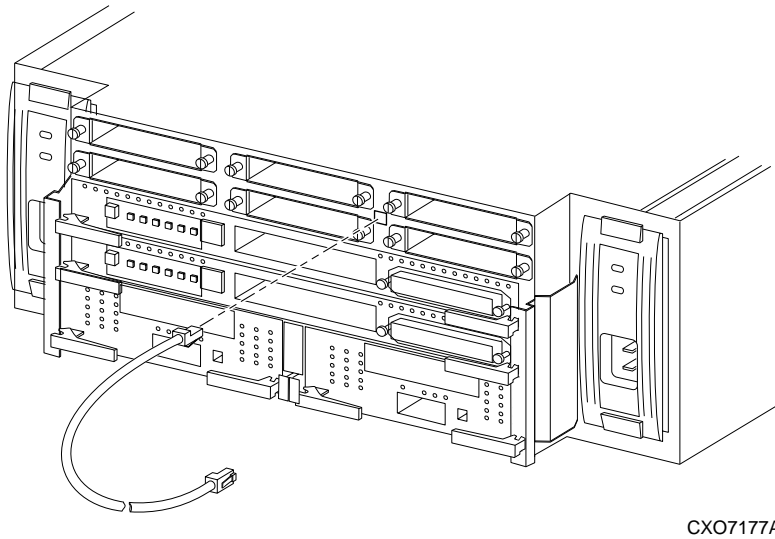

Figure 1-4. Model 2200 enclosure UPS communication cable connection

Table 1-4 Model 2200 Enclosure UPS Communication Cable

Item	Description	Compaq Part Number	DIGITAL Part Number
1	UPS communication cable, 3 meter	133516-001	17-04875-01

HSG80 Array Controller

Figure 1-5 and Table 1-5 identify an HSG80 array controller, how to connect a Fibre Channel optical cable, and the location of the program card. This setup applies to both the BA370 enclosure and Model 2200 enclosure.

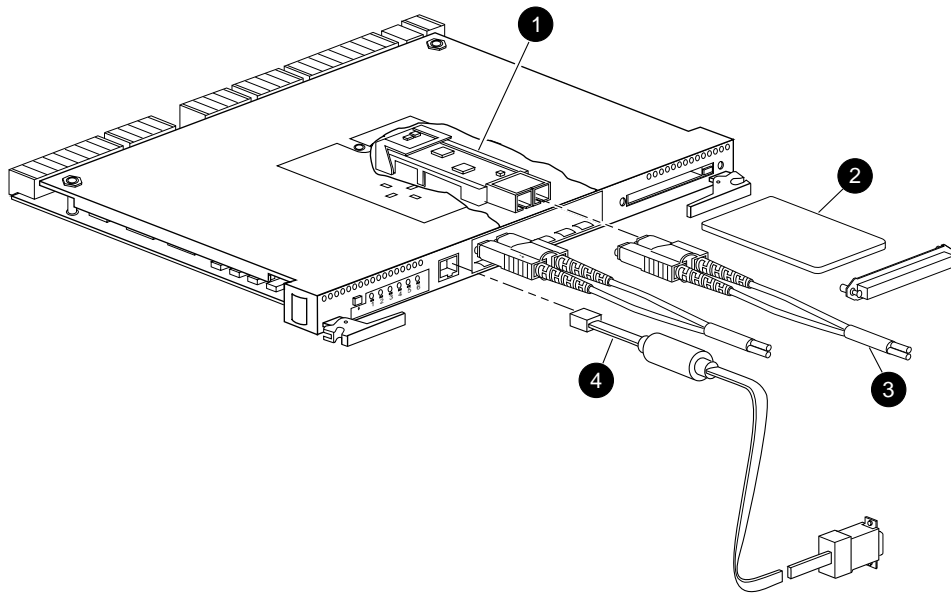

CXO6691B

Figure 1-5. HSG80 array controller—Fibre Channel optical cabling and program card

Table 1-5 HSG80 Fibre Channel Array Controller

Item	Description	Compaq Part Number	DIGITAL Part Number
①	Gigabit link module (GLM)	402603-001	70-GLMS1-02
②	Program cards:		
	- ACS V8.5F	170569-001	BG-RHQEB-BA
	- ACS V8.5P	170570-001	BG-RHQDB-BA
	- ACS V8.5S	170571-001	BG-RKEGA-BA
③	Fibre Channel optical cable, 2 meter	242796-001	17-04820-03
	Fibre Channel optical cable, 5 meter	242796-002	17-04820-05
	Fibre Channel optical cable, 15 meter	242796-003	17-04820-13
	Fibre Channel optical cable, 30 meter	401937-001	17-04820-08
	Fibre Channel optical cable, 50 meter	401938-001	17-04820-09
④	Maintenance port cable to a PC	173408-001	17-04074-04
	Adapters, 9-pin D-sub to 25-pin D-sub (not shown):		
	- Male to female (null modem)	173407-001	12-45238-01
	- Male to male (null modem)	173407-002	12-45238-02
	- Male to male (modem)	173407-003	12-45238-03

Cache Module

Figure 1-6 and Table 1-6 identify the cache module and the location of dual inline memory module (DIMM).

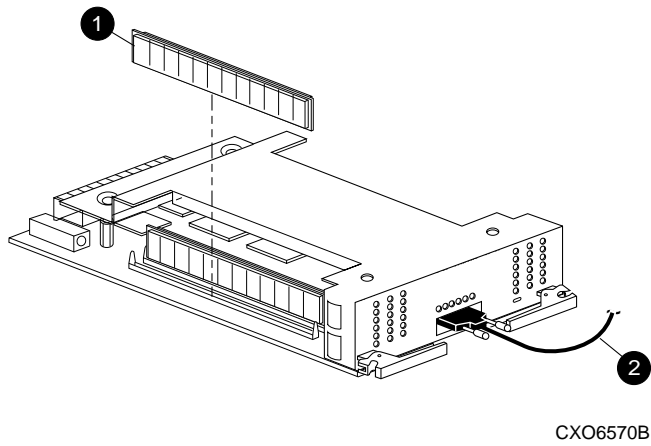

Figure 1-6. Cache module

Table 1-6 Cache Module

Item	Description	Compaq Part Number	DIGITAL Part Number
❶	Dual inline memory module (DIMM), 32 MB	400296-001	70-DIMS1-01
	DIMM, 128 MB	400297-001	70-DIMS1-02
❷	BA370 enclosure only:		
	ECB Y-cable for the BA370 enclosure	400298-001	17-04479-03
	ECB Y-cable for the data center cabinet	401913-001	17-04479-04

Connectors, Switches, and LEDs

This section provides connector, switches, and LED information for the following components:

- HSG80 array controller
- BA370 enclosure PVA module
- BA370 enclosure and Model 2200 enclosure EMUs
- Model 2200 enclosure ECB and fans
- 180 W power supply

HSG80 Array Controller Front Panel

Figure 1-7 and Table 1-7 identify various physical attributes of the HSG80 array controller.

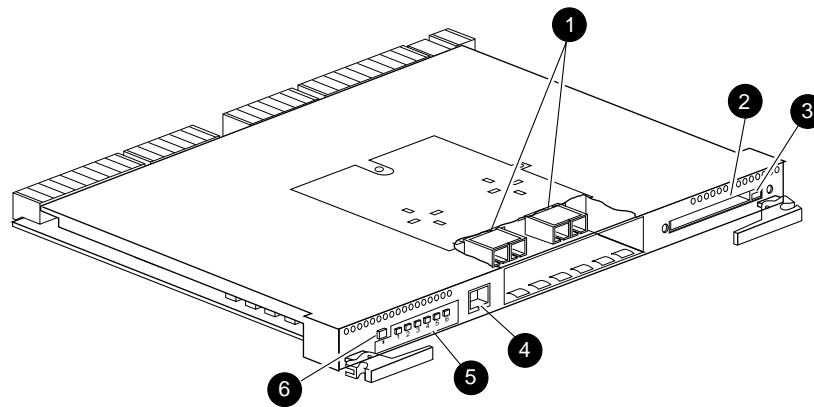

CXO6582B

Figure 1-7. HSG80 array controller front panel connectors, switches, and LEDs

Table 1-7 HSG80 Array Controller Front Panel Connectors, Switches, and LEDs

Location	Description
❶	GLM connection ports
❷	Program card slot
❸	Program card ejection button
❹	Maintenance port
❺	Operator control panel (OCP)
❻	Controller reset button

Array Controller OCP LEDs

Figure 1-8 and Table 1-8 identify the OCP switches and LEDs on an array controller.

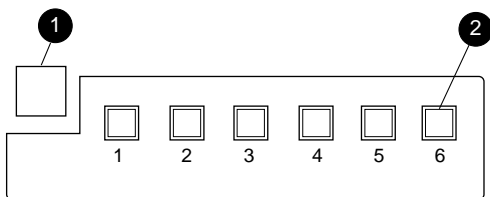

CXO6216C

Figure 1-8. Array controller OCP switches and LEDs

Table 1-8 OCP Switches and LEDs

Location	Description
❶	Controller reset button
❷	Port buttons/LEDs (1 through 6)

GLM Connectors and Components

Figure 1-9 and Table 1-9 identify various GLM components on the HSG80 array controller.

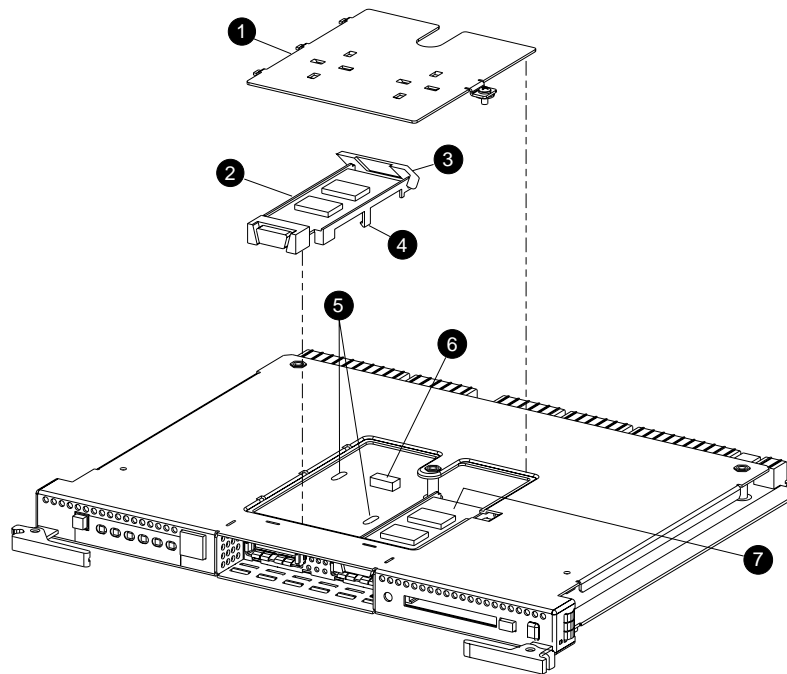

CXO6245C

Figure 1-9. GLM connectors and components

Table 1-9 GLM Connectors and Components	
Location	Description
①	Access door
②	Port 1 GLM
③	Release lever
④	Locking tab
⑤	Guide holes
⑥	GLM connector
⑦	Port 2 GLM

180 W Power Supply LEDs

Figure 1-10 and Table 1-10 identify power supply LEDs for both the BA370 enclosure and Model 2200 enclosure.

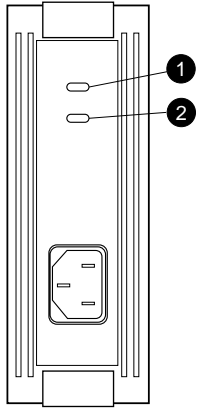

CXO6357A

Figure 1-10. 180 W power supply LEDs

Table 1-10 180 W Power Supply LEDs

Location	Description
❶	Shelf (enclosure) status LED
❷	Power supply status LED

BA370 Enclosure PVA Module Connector and Switches

Figure 1–11 and Table 1–11 identify PVA connector and switches for a BA370 enclosure.

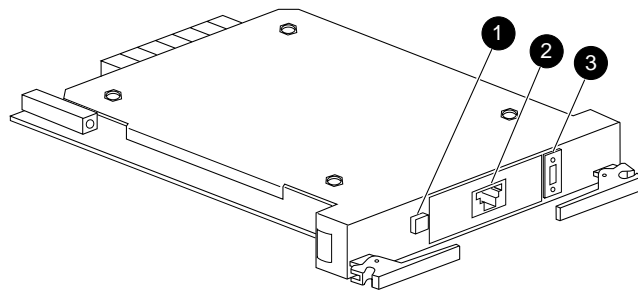

CXO5821B

Figure 1–11. BA370 enclosure PVA connector and switches

Table 1–11 BA370 Enclosure PVA Connectors and Switches

Location	Description
①	Standby power switch
②	Communications port
③	SCSI ID switch

BA370 Enclosure EMU Connectors, Switches, and LEDs

Figure 1-12 and Table 1-12 identify EMU connectors, switches, and LEDs for a BA370 enclosure.

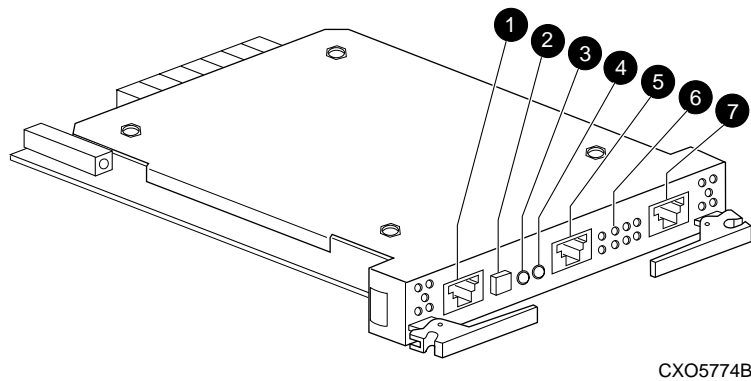
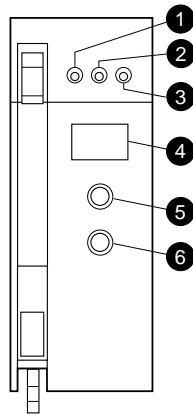

Figure 1-12. BA370 enclosure EMU connectors, switches, and LEDs

Table 1-12 BA370 Enclosure EMU Connectors, Switches, and LEDs	
Location	Description
①	EMU communications connector (labeled IIC)
②	System fault LED and alarm control switch
③	Temperature fault LED
④	Power status LED
⑤	Maintenance terminal connector
⑥	Blower fault LEDs (eight LEDs)
⑦	EMU communications connector (labeled IIC)

Model 2200 Enclosure EMU Switches and LEDs

Figure 1-13 and Table 1-13 identify EMU switches and LEDs for a Model 2200 enclosure.



CXO6355A

Figure 1-13. Model 2200 enclosure EMU switches and LEDs

Table 1-13 Model 2200 Enclosure EMU Switches and LEDs	
Location	Description
①	EMU status LED
②	Power status LED
③	Enclosure fault LED
④	Alphanumeric display
⑤	Increment switch/LED
⑥	Group switch/LED

Model 2200 Enclosure ECB LEDs

Figure 1-14 and Table 1-14 identify ECB LEDs for a Model 2200 enclosure.

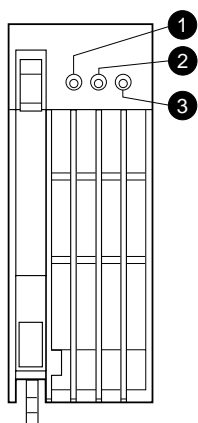

CXO6358A

Figure 1-14. Model 2200 enclosure ECB LEDs

Table 1-14 Model 2200 Enclosure ECB LEDs

Location	Description
①	ECB charged LED
②	ECB charging LED
③	ECB fault LED

Model 2200 Enclosure Fan LEDs

Figure 1-15 and Table 1-15 identify fan LEDs for a Model 2200 enclosure.

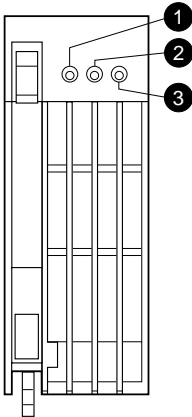

CXO6358A

Figure 1-15. Model 2200 enclosure Fan LEDs

Table 1-15 Model 2200 Enclosure Fan LEDs	
Location	Description
①	Power status LED
②	Not used
③	Fan fault LED

Chapter 2

Common Replacement Information and Procedures

This chapter contains the following replacement information and procedures:

- Required Tools
- Precautions
- Preparation Procedures
- Fibre Channel Optical Cable Cleaning Instructions
- Cleaning the GLM
- Replacing a GLM
- Replacing DIMMs
- Replacing a Fiber Cable, Switch, or Hub
- Replacing a Program Card
- Replacing a Failed Stageset Member

Required Tools

The following tools are needed to service a controller, cache module, BA370 enclosure ECB, BA370 enclosure PVA module, GLM, and I/O module:

- a flathead screwdriver for loosening and tightening the I/O module retaining screws
- a small phillips screwdriver for loosening and tightening the GLM access door screws
- a pair of needle-nose pliers to remove the switch cables from the controller

- an antistatic wrist strap
- an antistatic mat on which to place modules during servicing

Precautions

Follow the precautions in this section when carrying out the procedures in this guide.

Component Precaution

System components referenced in this manual comply with regulatory standards documented herein. Use of other components in their place might violate country standards, negate regulatory compliance, or invalidate the product warranty.

Electrostatic Discharge Precautions

Static electricity collects on all nonconducting material, such as paper, cloth, and plastic. An electrostatic discharge (ESD) can easily damage a controller or other subsystem component even though the discharge might not be seen or felt. ESD is a common problem and might cause data loss, system down time, and other problems. The most common source of static electricity is the movement of people in contact with carpets and clothing. Low humidity also increases the amount of static electricity. Discharge all static electricity prior to touching electronic equipment.

Observe the following precautions whenever servicing a subsystem or one of its components:

- Always use an ESD wrist strap when servicing the controller or other components in the subsystem. Make sure that the strap contacts bare skin, fits snugly, and that its grounding lead is attached to a bus that is a verified earth ground.
- Before touching any circuit board or component, always touch a verifiable earth ground to discharge any static electricity that might be present in clothing.
- Always keep circuit boards and components away from nonconducting material.
- Always keep clothing away from circuit boards and components.
- Always use antistatic bags and grounding mats for storing circuit boards or components during replacement procedures.

- Always keep the ESD cover over the program card when the card is in the controller. If you remove the card, put it in its original carrying case. Never touch the contacts or twist or bend the card while handling it.
- Never touch the connector pins of a cable when it is attached to a component or host.

Maintenance Port Precautions

The maintenance port generates, uses, and radiates radio-frequency energy through cables that are connected to it. This energy might interfere with radio and television reception. Do not leave a cable connected to this port when not communicating with the controller.

Preparation Procedures

Establishing a Local Connection to the Controller

Communication with a controller is done locally or remotely. Use a local connection to configure the controller for the first time. Use a remote connection to the host system for all subsequent configuration tasks. See the *Compaq StorageWorks HSG80 Array Controller ACS Version 8.5 Configuration Guide* and specific Installation Reference Guide that came with the platform kit for details.

The maintenance port provides a convenient way to connect a PC or terminal to the controller for troubleshooting and configuring the controller. This port accepts a standard RS-232 jack from any EIA-423 compatible terminal or a PC with a terminal-emulation program. The maintenance port supports serial communications with default values of 9600 baud using 8 data bits, 1 stop bit, and no parity.

NOTE: A maintenance port cable (see Figure 2-1) is provided for connecting to a PC. This cable has a 9-pin connector molded onto one end that three optional adapters can be attached for making a maintenance terminal connection.

Use the following steps to establish a local connection for setting the controller initial configuration:

1. Turn off the PC or terminal, and connect it to the controller, as shown in Figure 2-1.
 - a. For a PC connection, plug one end of the maintenance port cable into the terminal; plug the other end into the controller maintenance port.
 - b. For a terminal connection, refer to Figure 2-1 for cabling information.

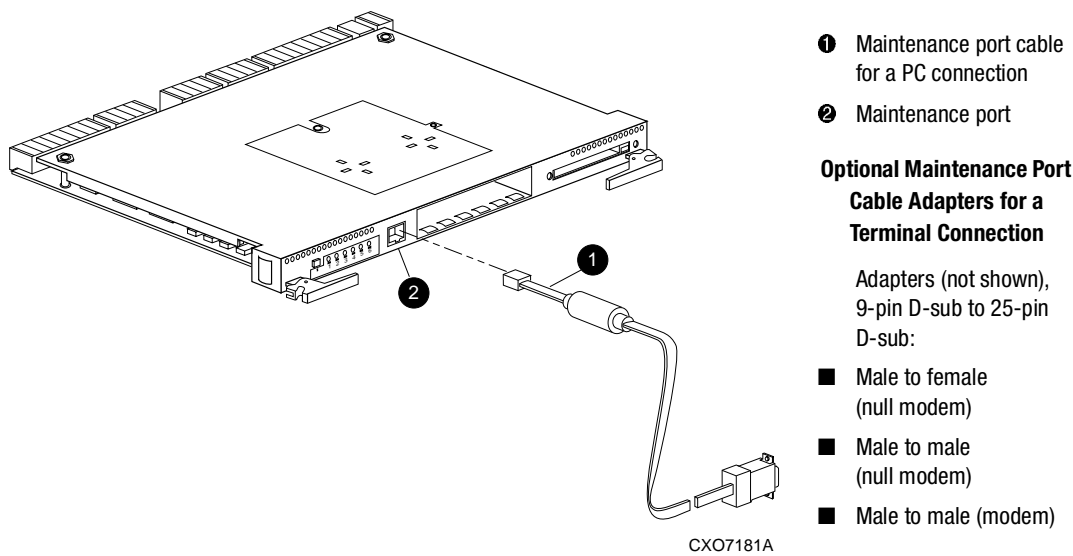

Figure 2-1. PC/terminal to maintenance port connection



CAUTION: The cables connecting the controller and the PC (or terminal) might cause radio and television interference. Only connect a PC or terminal to the controller via the maintenance port when communication with the controller is necessary.

2. Turn on the PC or terminal.
3. Configure the terminal emulation software for 9600 baud, 8 data bits, 1 stop bit, and no parity.
4. Press the **Enter** or **Return** key. The command line interface (CLI) prompt appears, indicating that a local connection was established with the controller.

NOTE: The default data transfer rate of a new controller is 9600 baud. The maximum transfer rate is 19200. If the current configuration used 19200, use step 5 to establish this rate.

5. Optional step: To increase the data transfer rate to 19200 baud:
 - a. Set the controller to 19200 baud with one of the following commands:

```
SET THIS_CONTROLLER TERMINAL SPEED=19200
```

```
SET OTHER_CONTROLLER TERMINAL SPEED=19200
```

- b. Configure the PC or terminal for 19200 baud.

When entering CLI commands in a dual-redundant controller configuration, remember that the controller connected to is “this controller” and the remaining controller is the “other controller.”

Fibre Channel Optical Cable Cleaning Instructions

It is essential to clean the Fibre Channel optical cables when replacing the controller to ensure optimum performance and lifespan of the cable. Use the polyester cloth from the cleaning kit that came with the cable. Figure 2-2 shows the ferrule on an optical cable.

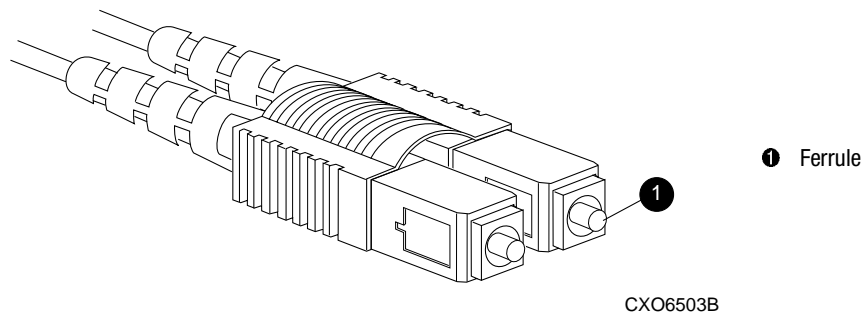

Figure 2-2. Ferrule on an optical cable



CAUTION: It is only necessary to clean the Fibre Channel optical cable when replacing a controller. Overcleaning might cause damage to the ferrules.

NOTE: When installing a cable for the first time, it is not necessary to follow this procedure.

1. Using the polyester cleaning cloth that came with the cable cleaning kit, cover your fingers and squeeze one ferrule between two fingers.
2. Rotate the cloth around the ferrule one or two times.
3. When the first ferrule is clean, move your fingers to a different area of the cloth and repeat step 1 and step 2 for the remaining ferrule.

Cleaning the GLM

When replacing a GLM, it is important to clean its receptacles to ensure optimum performance. Use the following steps to clean a GLM:

1. Take out the polyester swab from the cleaning kit that came with the Fibre Channel optical cable.



CAUTION: Do not exert excessive force when the swab reaches its stopping point, and do not repeat this procedure frequently. Failure to comply with this caution might cause scratching on the GLM and ultimately damage the optic connection. Overcleaning might cause damage to the GLM.

2. Gently insert the lint-free polyester swab into the transmit-side of the optical GLM cavity (see Figure 2-3).

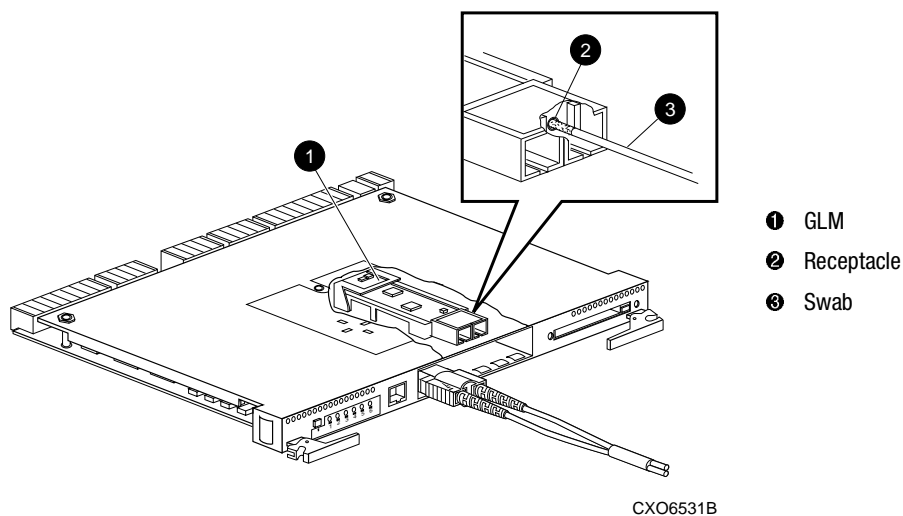

Figure 2-3. Cleaning procedure for GLM

3. Carefully dust out the cavity by rotating the swab tip back and forth one or two times.
4. Repeat step 1 through step 3 for the receiving side of the optical GLM cavity.

Replacing a GLM

Use the following steps in “Removing a GLM” and “Installing a GLM” to replace a GLM in a controller. Figure 2-4 shows the location and orientation of the GLMs.

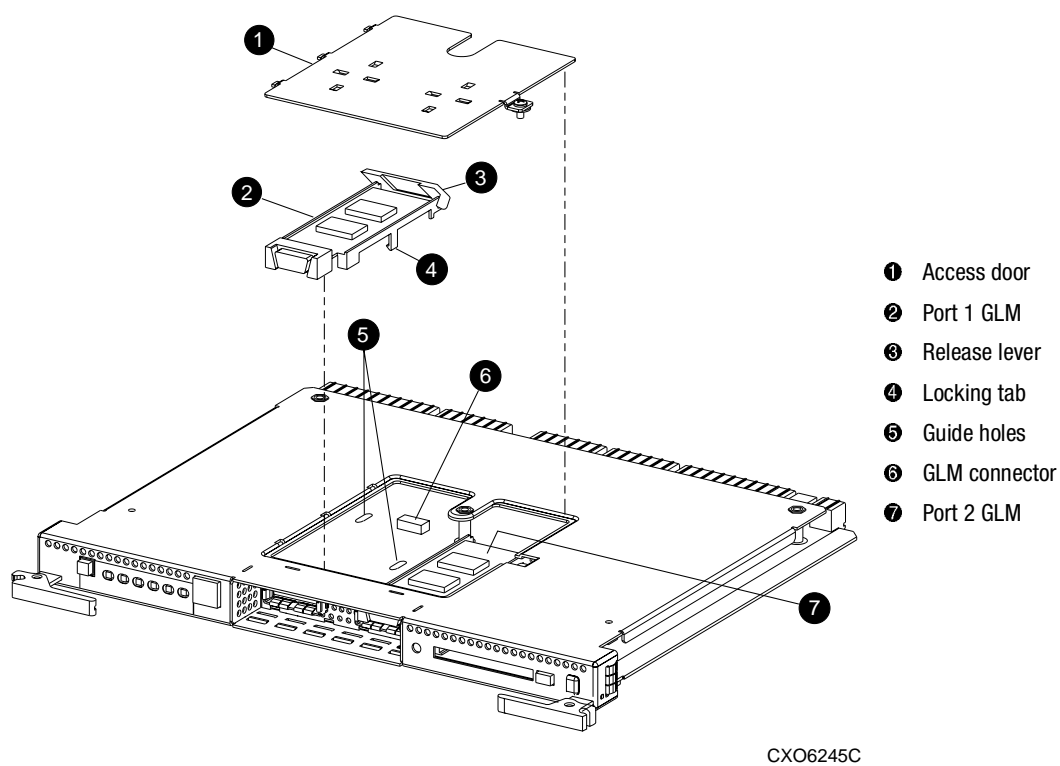

Figure 2-4. Location of GLMs inside a controller



CAUTION: ESD can easily damage a controller and GLM. Wear a snug-fitting, grounded ESD wrist strap.

Removing a GLM

Use the following steps and Figure 2-4 to remove a GLM:

1. Remove the controller using steps in either Chapter 3 or Chapter 4.
2. Remove the screw that secures the access door ❶ on the top of the controller.
3. Remove the access door and set it aside.
4. Disengage the GLM locking tabs ❷ that protrude through the guide holes ❸ on the bottom side of the controller.
5. Use your index finger and thumb to operate the release lever ❹ on the exposed end of the GLM. Press the lower end of the release lever with your index finger while pulling the raised end of the release lever up with your thumb.
6. Remove the GLM.

Installing a GLM

Use the following steps and Figure 2-4 to install a GLM:

NOTE: Before inserting the new GLM, note the holes in the board where the GLM will reside.

1. Insert the new GLM by first placing the cable connection end of the GLM through the opening on the front of the controller.
2. Line up the locking tab ❷ on the bottom of the replacement GLM with the guide holes ❸ in the board, and press firmly to seat the GLM.
3. Press the release lever firmly into place to secure the GLM.
4. Install the access door ❶ on the top of the controller and secure it with the screw.
5. Install the controller using steps in either Chapter 3 or Chapter 4.

Replacing DIMMs

Use the following steps in “Removing DIMMs” and “Installing DIMMs” to replace DIMMs in a cache module. DIMM locations are shown in Figure 2-5 and supported configurations are shown in Table 2-1.

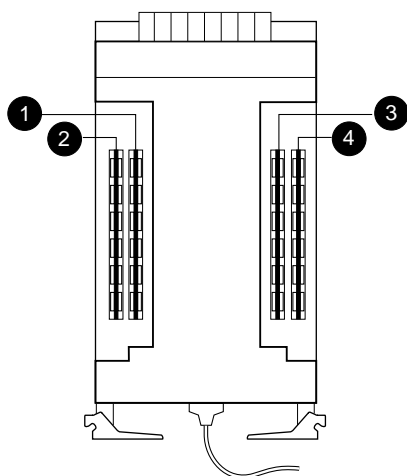

CXO6576B

Figure 2-5. Cache module DIMM locations

Table 2-1 Cache Module Memory Configurations			
Memory	DIMMs	Quantity	Location
64 MB	32 MB	2	① ③
128 MB	32 MB	4	① ② ③ ④
256 MB	128 MB	2	① ③
512 MB	128 MB	4	① ② ③ ④



CAUTION: ESD can easily damage a cache module or a DIMM. Wear a snug-fitting, grounded ESD wrist strap.

NOTE: If a DIMM fails, note which DIMM needs replacement based on the diagram displayed on the console.

Use Figure 2-6 during the removal and installation procedures for component clarification.

Removing DIMMs

Use the following steps to remove a DIMM from a cache module:

1. Remove the cache module using steps in either Chapter 3 or Chapter 4.
2. Press the DIMM retaining clip ❸ down at both ends of the DIMM ❶ being removed (see Figure 2-6).
3. Gently remove the DIMM from the DIMM slot ❷ and place it on an antistatic bag or grounded antistatic mat.
4. Repeat step 2 and step 3 for each DIMM.

Installing DIMMs

Use the following steps to install a DIMM in a cache module:

IMPORTANT: For ACS V8.5P installations, the required cache memory configuration is 512 MB.
For ACS V8.5S, *Compaq* strongly recommends using 512 MB of cache memory.

1. Insert each DIMM ❶ straight into the appropriate slot ❷ of the cache module, ensuring that the notches in the DIMM align with the tabs in the slot (see Figure 2-6).
2. Press the DIMM gently into the slot until seated at both ends.
3. Engage both retaining clips ❸ for the DIMM.
4. Repeat step 1 through step 3 for each DIMM.
5. Install the cache module using steps in either Chapter 3 or Chapter 4.

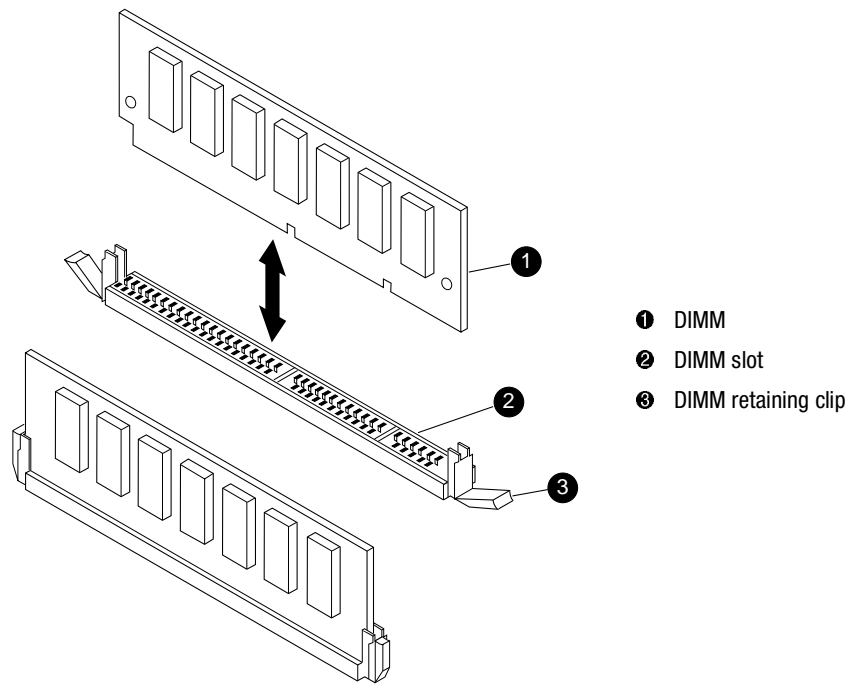

CXO6577B

Figure 2-6. DIMM components

Replacing a Fiber Cable, Switch, or Hub

Use the following steps in “Remove a Fiber Cable, Switch, or Hub” and “Install a Fiber Cable, Switch, or Hub” to replace a fiber cable, switch, or hub.

Remove a Fiber Cable, Switch, or Hub

Use the following steps to remove a cable connected to either side of your switch or hub, or to remove the switch or hub:

1. Shut down the host system using host documentation.
2. Shut down the controllers.
 - In single-controller configurations, shut down “this controller” with the following command:

```
SHUTDOWN THIS_CONTROLLER
```

- In dual-redundant controller configurations, shut down the “other controller” first, then shut down “this controller” with the following commands:

```
SHUTDOWN OTHER_CONTROLLER
```

```
SHUTDOWN THIS_CONTROLLER
```

When the controllers shut down, the reset buttons and the first three LEDs turn ON (see Figure 2-7). It might take several minutes for this indication to appear, depending on the amount of data that needs to be flushed from the cache modules.

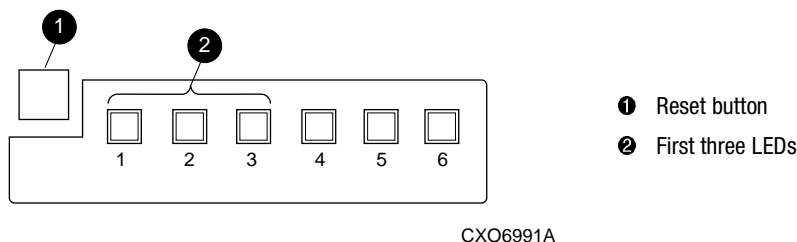
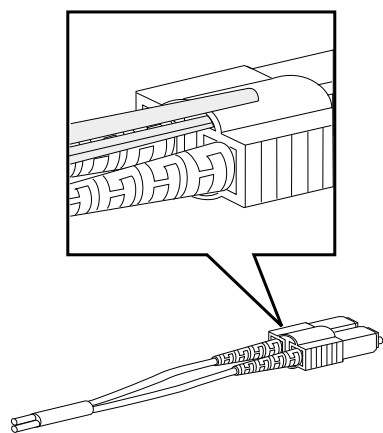

Figure 2-7. Controller reset button and first three LEDs

IMPORTANT: When replacing several cables, a switch, or a hub, label each cable to facilitate installation of the replacement item. Otherwise, subsystem errors will develop from improper connections.

3. If replacing a cable, disconnect the failed cable at each end using needle nose pliers (see inset on Figure 2-8).

If replacing a switch or hub, disconnect all cables connected it.



CXO6613A

Figure 2-8. Using pliers to disconnect an optical cable

Install a Fiber Cable, Switch, or Hub

Use the following steps to install a cable connected to either side of a switch or hub, or to install a switch or hub:

1. If replacing a cable, connect the replacement cable into the ports previously used by the old cable.
If replacing a switch or hub, reconnect all cables removed from the old switch or hub.
2. Restart each controller by pressing its reset button.
The controllers automatically restart and the subsystem is now ready for operation.
3. Restart the host system using host documentation.

Replacing a Program Card

Use the following steps to replace a program (Personal Computer Memory Card Industry Association—PCMCIA) card (see Figure 2-9):

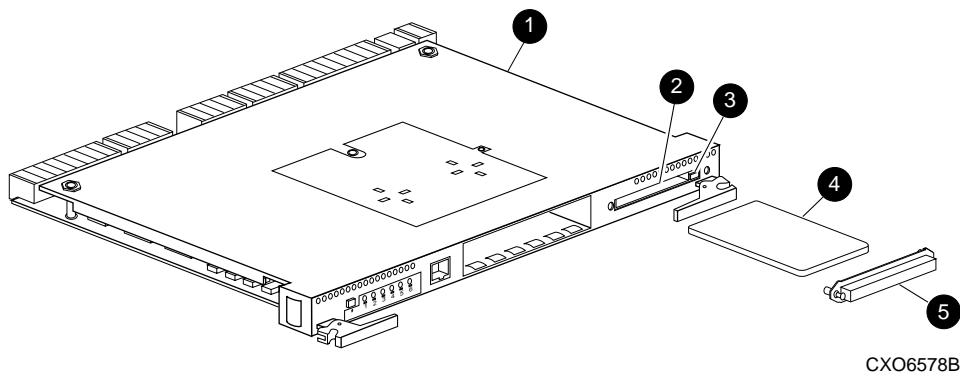

- | | | | | |
|--------------|---------------------|--------------------------------|-------------------------|--------------------------|
| ❶ Controller | ❷ Program card slot | ❸ Program card ejection button | ❹ Program (PCMCIA) card | ❺ Program card ESD cover |
|--------------|---------------------|--------------------------------|-------------------------|--------------------------|

Figure 2-9. Program (PCMCIA) card location and components



CAUTION: The replacement program card must have the same software version as the original program card being replaced. See Chapter 5 for more information.

1. From a host console, stop all host activity and dismount the logical units in the subsystem. If using a Windows NT platform, shut down the server.
2. Connect a PC or terminal to a controller maintenance port.
3. Shut down the controllers.
 - In single-controller configurations, shut down “this controller” with the following command:
`SHUTDOWN THIS_CONTROLLER`
 - In dual-redundant controller configurations, shut down the “other controller” first, then shut down “this controller” with the following commands:
`SHUTDOWN OTHER_CONTROLLER`
`SHUTDOWN THIS_CONTROLLER`

When the controllers shut down, the reset buttons and the first three LEDs turn ON (see Figure 2-7). It might take several minutes for this indication to appear, depending on the amount of data that needs to be flushed from the cache modules.

4. Remove the program card ESD cover ⑤ on “this controller.”
5. Press and hold the reset button while ejecting the program card ④ from “this controller” by pressing the program card eject button ⑥.
6. Press and hold the reset button while inserting the replacement program card.
The “this controller” automatically restarts and is ready to handle I/O once the CLI becomes responsive.
7. Replace the program card ESD cover on “this controller.”
8. For BA370 enclosures, verify that the master enclosure PVA SCSI ID number reads ID 0. If not, reset it to ID 0.
9. In a dual-redundant controller configuration, repeat step 4 through step 7 for the “other controller.”
10. Mount the logical units on the host. If using a Windows NT platform, restart the server.

Replacing a Failed StorageSet Member

If a disk drive fails in a RAIDset or mirrorset, the controller automatically places it into the failedset. If the spareset contains a replacement drive that satisfies the storageSet replacement policy, the controller automatically replaces the failed member with the replacement drive. If the spareset is empty or does not contain a satisfactory drive, the controller simply “reduces” the storageSet so that it can operate without one of its members.

The storageSet remains in this “reduced” state until the spareset contains a satisfactory drive. If the controller senses a satisfactory drive in the spareset, it automatically places the drive into the storageSet and restores the storageSet to normal. Therefore, *replacing a failed storageSet member means putting a satisfactory drive into the spareset.*

Removing a Failed RAIDset or Mirrorset Member

Use the following steps to remove a failed RAIDset or mirrorset member:

1. Connect a PC or terminal to the controller maintenance port that accesses the reduced RAIDset or mirrorset.
2. Enable AUTOSPARE with the following command:

```
SET FAILEDSET AUTOSPARE
```

With AUTOSPARE enabled, any new disk drive—one that has not been in an array before—inserted into the Port-Target-LUN (PTL) location of a failed disk drive is automatically initialized and placed into the spareset.

3. Remove the failed disk drive.

Installing the New Member

Use the following instruction to install a new member:

NOTE: The controller automatically initializes a new disk drive and places it into the spareset. As soon as the disk drive becomes a member of the spareset, the controller automatically uses it to restore the reduced RAIDset or mirrorset. If initialization of the new disk drive fails, it is placed into the failedset.

Insert a new disk drive that satisfies the replacement policy of the reduced storageset into the PTL location of the failed disk drive.

Chapter 3

Replacement Procedures for BA370 Enclosure Elements

This chapter provides procedures for shutting down and restarting the subsystem and procedures for replacing the following BA370 enclosure elements:

- Array controller
- Cache module
- ECB
- PVA module
- I/O module
- EMU

See enclosure documentation for information about replacing power supplies, AC input boxes, cooling fans, bus cables, and power cables.

Shutting Down the Subsystem

Use the following steps to shut down a subsystem.

1. From a host console, stop all host activity and dismount the logical units in the subsystem. If using a Microsoft Windows NT platform, shut down the server.
2. Connect a PC or terminal to the maintenance port of one of the controllers in the subsystem.

3. Shut down the controllers.

- In single-controller configurations, shut down “this controller” with the following command:

```
SHUTDOWN THIS_CONTROLLER
```

- In dual-redundant controller configurations, shut down the “other controller” first, then shut down “this controller” with the following commands:

```
SHUTDOWN OTHER_CONTROLLER
```

```
SHUTDOWN THIS_CONTROLLER
```

When the controllers shut down, the reset buttons and the first three LEDs turn ON (see Figure 3-1). It might take several minutes for this indication to appear, depending on the amount of data that needs to be flushed from the cache modules.

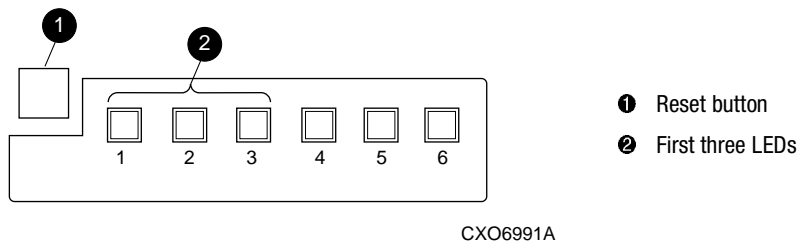

Figure 3-1. Controller reset button and first three LEDs

4. Remove power to the subsystem.



CAUTION: If shutting down the controller for longer than one day, perform the steps in the next section, “Disabling and Enabling the External Cache Batteries” to prevent the write-back cache batteries from discharging.

Disabling and Enabling the External Cache Batteries—Use the following steps to disable the ECBs.

NOTE: The ECB might contain one or two batteries, depending on the configuration.

1. Press and hold the battery disable switch labeled SHUT OFF (see Figure 3-2) for approximately 5 seconds. The ECB status LED will flash once and then shut off.

2. Repeat step 1 for the second battery in dual ECB components and for both ECB 1 and ECB 2, if appropriate.

The batteries are no longer powering the cache module.

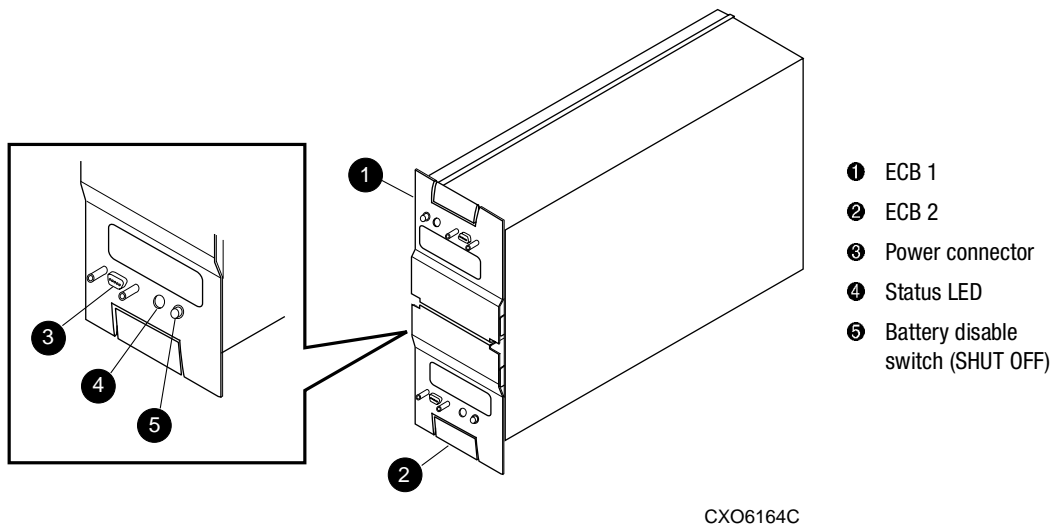

Figure 3-2. ECB battery disable switch location

NOTE: To return to normal operation, apply power to the storage subsystem. The ECB will be enabled when the subsystem is powered on.

Restarting the Subsystem

Use the following steps to restart a subsystem.

1. Refer to enclosure documentation for specific procedures to follow for restarting the subsystem.
Once power is applied to the subsystem, the controllers automatically restart and the ECBs are automatically “re-enable” to provide backup power to the cache modules.
2. Mount the logical units on the host. If using a Windows NT platform, restart the server.

Replacing Controller and Cache Modules in a Single-Controller Configuration

Follow the instructions in this section to replace modules in a single-controller configuration (see Figure 3-3). To upgrade a single-controller configuration to a dual-redundant controller configuration, see Chapter 5.

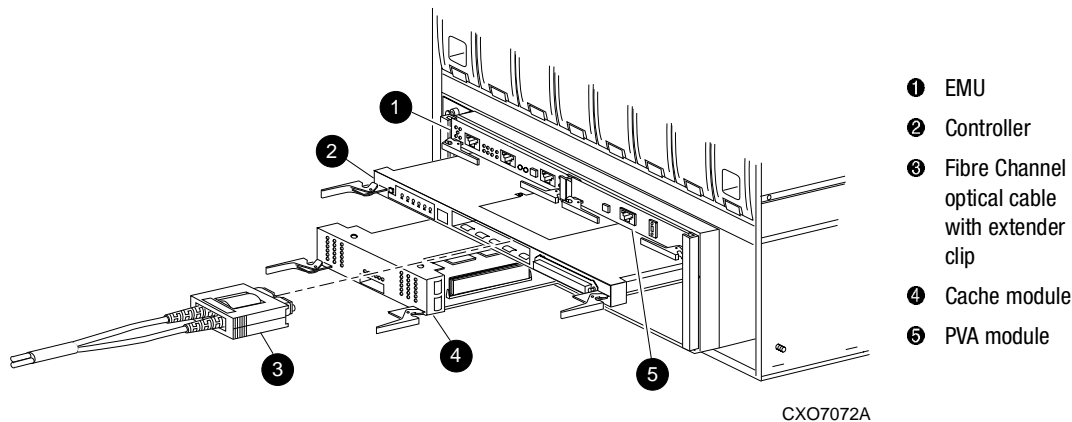

Figure 3-3. Single-controller configuration

The following sections contain procedures that replace both the controller and cache module, replace only the controller, and replace only the cache module.



CAUTION: In a single-controller configuration, always shut down the subsystem before removing or replacing any modules. Otherwise, data loss might occur.

For Fibre Channel optical cables without extender clips, the use of pliers is necessary to remove the cable from the controller without potentially damaging the cable.

IMPORTANT: For single-controller configurations, the only supported controller and cache module bays are Controller A and Cache A. *Do not* use Controller B and Cache B bays instead of Controller A and Cache A bays.

Replacing a Controller and Cache Module in a Single-Controller Configuration

If both the controller and cache module need to be replaced, replace the controller first and then the cache module. This section contains steps for each procedure.

Replacing a Controller in a Single-Controller Configuration

Use the procedures in “Removing the Controller in a Single-Controller Configuration” and “Installing the Controller in a Single-Controller Configuration” to replace a controller.



CAUTION: ESD can easily damage a controller. Wear a snug-fitting, grounded ESD wrist strap.

Removing the Controller in a Single-Controller Configuration

Use the following steps to remove a controller.

1. From the host console, dismount the logical units in the subsystem. If using a Windows NT platform, shut down the server.
2. If the controller is operating, connect a PC or terminal to the controller maintenance port.
If the controller is not operating, go to step 6.
3. Run the fault management utility (FMU) to obtain the last failure codes, if desired.
4. Is a disk initialized with the SAVE_CONFIGURATION switch?
 - Yes. Use the following command to save the current device configuration for “this controller:”

```
CONFIGURATION SAVE
```
 - No. Locate existing information that will support the manual configuration of the subsystem. The new controller must be manually configured as described in *Compaq StorageWorks HSG80 Array Controller ACS Version 8.5 CLI Reference Guide*.

5. Shut down the controller with the following command:

SHUTDOWN THIS_CONTROLLER

When the controller shuts down, the reset button and the first three LEDs turn ON (see Figure 3-1). It might take several minutes for this indication to appear, depending on the amount of data that needs to be flushed from the cache modules.



CAUTION: The cache module might contain unwritten data if the controller crashes and the controller cannot be shut down with the SHUTDOWN THIS_CONTROLLER command.

6. Remove the program card ESD cover and program card. Save them in a static-free place for the replacement controller.
7. Disconnect all host bus cables from the controller. For cables without extender clips, use needle nose pliers as shown in Figure 3-4 to disconnect the cable.

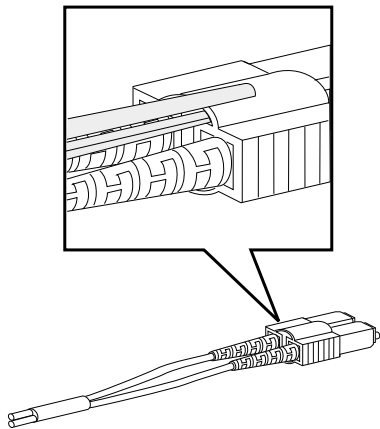

CXO6613A

Figure 3-4. Using pliers to disconnect an optical cable

8. If connected, disconnect the PC or terminal from the controller maintenance port.
9. Disengage both retaining levers and remove the controller.
10. Place the controller into an antistatic bag or onto a grounded antistatic mat.

Installing the Controller in a Single-Controller Configuration

Use the following steps to install a controller.



CAUTION: Carefully align the controller in the appropriate guide rails. Misaligning the module might damage the backplane.

1. Insert the new controller into its bay, and engage its retaining levers.
2. Connect all host bus cables to the new controller.
3. Connect a PC or terminal to the controller maintenance port.
4. Press and hold the reset button while inserting the program card into the new controller.
5. Release the reset button and replace the program card ESD cover.
6. When the CLI prompt reappears, display details about the configured controller using the following command:

```
SHOW THIS_CONTROLLER FULL
```

7. See the *Compaq StorageWorks HSG80 Array Controller ACS Version 8.5 CLI Reference Guide* to configure the controller.

NOTE: If the controller being installed was previously used in another subsystem, it will need to be purged of the old configuration (see CONFIG RESET in the *Compaq StorageWorks HSG80 Array Controller ACS Version 8.5 CLI Reference Guide*).

8. Does a disk contain the current device configuration saved on it?
 - Yes. Automatically restore the configuration as follows:

IMPORTANT: In the following step, hold the buttons until the Port Buttons start FLASHING, before releasing the two buttons.

- a. Press and hold the Port Button #6 (see Figure 3-5, ②) and then press and hold the RESET button ① until the port buttons start FLASHING.

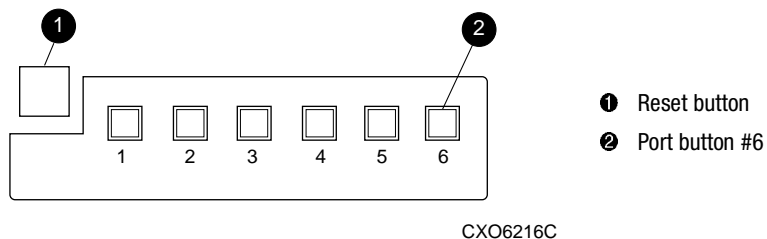

Figure 3-5. Location of array controller reset and port #6 buttons on the OCP

- b. Release the two buttons to initiate the configuration restore.
 - No. Manually restore the current device configuration using existing information and the *Compaq StorageWorks HSG80 Array Controller ACS Version 8.5 CLI Reference Guide*.
9. Using code-load/code-patch utility (CLCP), install any patches that were installed on the previous controller (see Chapter 5).
10. Mount the logical units on the host. If using a Windows NT platform, restart the server.
11. Set the subsystem date and time using the following command in its entirety:

```
SET THIS_CONTROLLER TIME=dd-mmm-yyyy:hh:mm:ss
```
12. Disconnect the PC or terminal from the controller maintenance port.

Replacing a Cache Module in a Single-Controller Configuration

Use the following steps in “Removing the Cache Module in a Single-Controller Configuration” and “Installing the Cache Module in a Single-Controller Configuration” to replace a cache module.



CAUTION: ESD can easily damage a cache module or DIMM. Wear a snug-fitting, grounded ESD wrist strap.

Removing the Cache Module in a Single-Controller Configuration

Use the following steps to remove a cache module.

1. From the host console, dismount the logical units in the subsystem. If using a Windows NT platform, shut down the server.
2. If the controller is operating, connect a PC or terminal to the controller maintenance port.
If the controller is not operating, go to step 5.
3. Run FMU to obtain the last failure codes, if desired.
4. Shut down the controller with the following command:

```
SHUTDOWN THIS_CONTROLLER
```

When the controller shuts down, the reset button and the first three LEDs turn ON (see Figure 3-1). It might take several minutes for this indication to appear, depending on the amount of data that needs to be flushed from the cache modules.



CAUTION: The ECB must be disabled—the status light is not lit and is not blinking—before disconnecting the ECB cable from the cache module. Failure to disable the ECB might damage the cache module.

5. Disable the ECB by pressing the battery disable switch until the status light stops blinking—approximately 5 seconds.
6. Disconnect the ECB cable from the cache module.
7. Disengage both retaining levers, remove the cache module, and place the cache module into an antistatic bag or onto a grounded antistatic mat.

NOTE: Remove the DIMMs from the cache module for use in the replacement cache module.

8. Press down on the DIMM retaining clips at both ends of the DIMM being removed.
9. Gently remove the DIMM from the DIMM slot and place it onto an antistatic bag or grounded antistatic mat.
10. Repeat step 8 and step 9 for each DIMM.

Installing the Cache Module in a Single-Controller Configuration

Use the following steps to install the cache module.



CAUTION: Carefully align the cache module in the appropriate guide rails. Misaligning the module might damage the backplane.

1. Insert each DIMM straight into the appropriate slot of the new cache module, ensuring that the notches in the DIMM align with the tabs in the slot (see Figure 2-6).
2. Press the DIMM gently into the slot until seated at both ends.
3. Engage two retaining clips for the DIMM.
4. Repeat step 1 through step 3 for each DIMM.
5. Insert the new cache module into its bay and engage its retaining levers.



CAUTION: The ECB must be disabled—the status light is not lit and is not blinking—before disconnecting the ECB cable from the cache module. Failure to disable the ECB might damage the cache module.

6. Disable the ECB by pressing the battery disable switch until the status light stops blinking—approximately 5 seconds.
7. Connect the ECB cable to the new cache module.
8. If not already connected, connect a PC or terminal to the controller maintenance port.
9. Restart the controller by pressing its reset button.
10. When the CLI prompt reappears, display details about the configured controller using the following command:

```
SHOW THIS_CONTROLLER FULL
```
11. Mount the logical units on the host. If using a Windows NT platform, restart the server.
12. Set the subsystem date and time using the following command in its entirety:

```
SET THIS_CONTROLLER TIME=dd-mmm-yyyy:hh:mm:ss
```
13. Disconnect the PC or terminal from the controller maintenance port.

Replacing Controller and Cache Modules in a Dual-Redundant Controller Configuration

Follow the instructions in this section to replace modules in a dual-redundant controller configuration (see Figure 3-6).

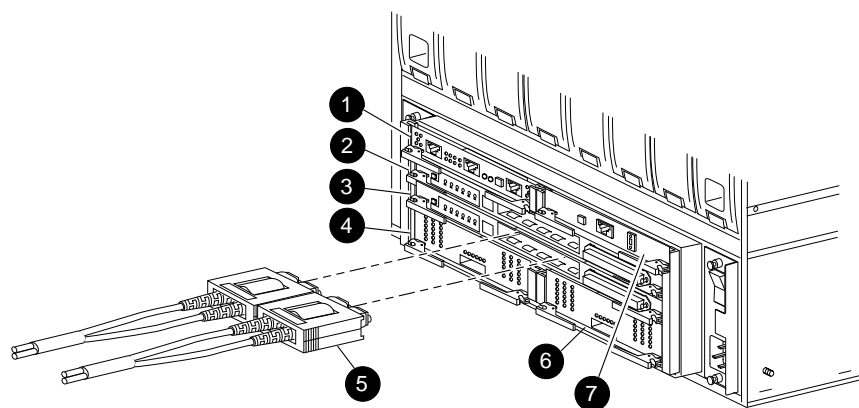

CXO6990A

- | | |
|------------------|--|
| ❶ EMU | ❺ Fibre Channel optical cables with extender clips |
| ❷ Controller A | ❻ Cache module B |
| ❸ Controller B | ❼ PVA module |
| ❹ Cache module A | |

Figure 3-6. Dual-redundant controller configuration

The following sections provide procedures for:

- Replacing both the controller and cache module
- Replacing a controller
- Replacing a cache module



CAUTION: For Fibre Channel optical cables without extender clips, the use of pliers is necessary to remove the cable from the controller without potentially damaging the cable.

IMPORTANT: Note the following before starting the replacement procedures:

- The new controller hardware must be compatible with the remaining controller hardware. See the product-specific release notes that accompanied the software release for information regarding hardware compatibility.
 - The software versions and patch levels must be the same on both controllers.
 - The new cache module must contain the same memory configuration as the module being replaced.
-

Replacing a Controller and Cache Module in a Dual-Redundant Controller Configuration

Use the following steps in “Removing a Controller and Cache Module in a Dual-Redundant Controller Configuration” and “Installing a Controller and its Cache Module in a Dual-Redundant Controller Configuration” to replace a controller and its cache module.



CAUTION: ESD can easily damage a controller, cache module, or DIMM. Wear a snug-fitting, grounded ESD wrist strap.

Both cache modules *must* contain the same cache memory configuration.

Removing a Controller and Cache Module in a Dual-Redundant Controller Configuration

Use the following steps to remove a controller and its cache module.

1. Connect a PC or terminal to the maintenance port of the operational controller.
The controller connected to becomes “this controller;” the controller being removed becomes the “other controller.”
2. Disable failover with the following command:

```
SET NOFAILOVER
```
3. Remove the program card ESD cover and program card from the “other controller.” Save them in a static-free place for the replacement controller.
4. Start field replacement utility (FRUTIL) with the following command:

```
RUN FRUTIL
```

The following display appears:

Do you intend to replace this controller's cache battery? Y/N

5. Enter **N(o)**. The following menu appears:

FRUTIL Main Menu:

1. Replace or remove a controller or cache module
2. Install a controller or cache module
3. Replace a PVA module
4. Replace an I/O module
5. Exit

Enter choice: 1, 2, 3, 4, or 5 ->

6. Enter option 1. The following menu appears:

Replace or remove Options:

1. Other controller and cache module
2. Other controller module
3. Other cache module
4. Exit

Enter choice: 1, 2, 3, or 4 ->

7. Enter option 1. The following display appears:

Slot Designations

(front view)

```
[ --- EMU --- ][ --- PVA --- ]
[ ----- Controller A ----- ]
[ ----- Controller B ----- ]
[ Cache Module A ][ Cache Module B ]
```

Remove both the slot A [or B] controller and cache module? Y/N

8. Enter **Y(es)**. The following display appears:

```
Quiescing all device ports. Please wait...
```

```
Device Port 1 quiesced.
```

```
Device Port 2 quiesced.
```

```
Device Port 3 quiesced.
```

```
Device Port 4 quiesced.
```

```
Device Port 5 quiesced.
```

```
Device Port 6 quiesced.
```

```
All device ports quiesced.
```

```
Remove the slot A [or B] controller (the one without a blinking green LED) within 4 minutes.
```



CAUTION: The device ports must quiesce before removing the controller. Failure to allow the ports to quiesce might result in data loss. Quiescing might take several minutes.

NOTE: A countdown timer allows a total of 4 minutes to remove both the controller and cache module. After 4 minutes, “this controller” exits FRUTIL and resumes operations. If this happens, return to step 4 and proceed.

9. Disconnect all host bus cables from the controller. For cables without extender clips, use needle nose pliers as shown in Figure 3-4 to disconnect each cable.
10. Disengage both retaining levers and remove the “other controller,” then place the controller into an antistatic bag or onto a grounded antistatic mat.

Once the controller is removed, the following display appears:

```
Remove the slot A [or B] cache module within x minutes, xx seconds.
```

11. Disengage both retaining levers and partially remove the “other controller” cache module—about half way.



CAUTION: The ECB must be disabled—the status light is not lit and is not blinking—before disconnecting the ECB cable from the cache module. Failure to disable the ECB might result in cache module damage.

12. Disable the ECB by pressing the battery disable switch until the status light stops blinking—approximately 5 seconds.
13. Disconnect the ECB cable from the “other controller” cache module, remove the cache module, and place it onto a grounded antistatic mat or into an antistatic bag.

Once the cache module is removed, the following display appears:

```
Restarting all device ports. Please wait...  
Device Port 1 restarted.  
Device Port 2 restarted.  
Device Port 3 restarted.  
Device Port 4 restarted.  
Device Port 5 restarted.  
Device Port 6 restarted.  
Do you have a replacement controller and cache module? Y/N
```

14. Is a replacement controller and cache module available now?

- If no, enter **N(o)**.
 - FRUTIL will exit.
 - Disconnect the PC or terminal from the controller maintenance port.
- If yes, remove the DIMMs from the cache module for installation in the replacement cache module.
 - a. Press the DIMM retaining clips down at both ends of the DIMM being removed.
 - b. Gently remove the DIMM from the DIMM slot and place it onto an antistatic bag or grounded antistatic mat.
 - c. Repeat step a and step b for each DIMM.
 - d. Insert each DIMM straight into the appropriate slot of the cache module, ensuring that the notches in the DIMM align with the tabs in the slot (see Figure 2-6).
 - e. Press the DIMM gently into the slot until seated at both ends.
 - f. Engage two retaining clips for the DIMM.
 - g. Repeat step d through step f for each DIMM.
 - h. Go to step 10 on page 3-17.

Installing a Controller and its Cache Module in a Dual-Redundant Controller Configuration

Use the following steps to install a controller and its cache module.



CAUTION: ESD can easily damage a controller, cache module, or DIMM. Wear a snug-fitting, grounded ESD wrist strap.

1. Insert each DIMM straight into the appropriate slot of the cache module, ensuring that the notches in the DIMM align with the tabs in the slot (see Figure 2-6).
2. Press the DIMM gently into the slot until seated at both ends.
3. Engage two retaining clips for the DIMM.
4. Repeat step 1 through step 3 for each DIMM.
5. Connect a PC or terminal to the maintenance port of the operational controller.
The controller connected to becomes “this controller;” the controller being installed becomes the “other controller.”
6. Start FRUTIL with the following command:

```
RUN FRUTIL
```

The following display appears:

```
Do you intend to replace this controller's cache battery? Y/N
```

7. Enter **N(o)**. The following menu appears:

```
FRUTIL Main Menu:
```

1. Replace or remove a controller or cache module
2. Install a controller or cache module
3. Replace a PVA module
4. Replace an I/O module
5. Exit

```
Enter choice: 1, 2, 3, 4, or 5 ->
```

8. Enter option 2. The following menu appears:

Install Options:

1. Other controller and cache module
2. Other controller module
3. Other cache module
4. Exit

Enter choice: 1, 2, 3, or 4 ->

9. Enter option 1. The following display appears:

Insert both the slot A [or B] controller and cache module? Y/N

10. Enter **Y**(es). The following display appears:

Quiescing all device ports. Please wait...

Device Port 1 quiesced.

Device Port 2 quiesced.

Device Port 3 quiesced.

Device Port 4 quiesced.

Device Port 5 quiesced.

Device Port 6 quiesced.

All device ports quiesced.

.

.

.

Perform the following steps:

1. Turn off the battery for the new cache module by pressing the battery's shut off button for five seconds
2. Connect the battery to the new cache module.
3. Insert the new cache module in slot A [or B] within 4 minutes.

NOTE: A countdown timer allows a total of 4 minutes to install both the cache module and controller. After 4 minutes, "this controller" will exit FRUTIL and resume operations. If this happens, return to step 6 and proceed.



CAUTION: The ECB must be disabled—the status light is not lit and is not blinking—before disconnecting the ECB cable from the cache module. Failure to disable the ECB might result in cache module damage.

Carefully align the cache module and controller in the appropriate guide rails. Misalignment might damage the backplane.

11. Disable the ECB by pressing the battery disable switch until the status light stops blinking—approximately 5 seconds.
12. Connect the ECB cable to the new cache module.
13. Insert the new cache module into its bay and engage its retaining levers. The following display appears:

Insert the controller module, WITH its program card, in slot A [or B] within x minutes, xx seconds.

14. Make sure that the program card is seated in the replacement controller, insert the new controller into its bay, and engage its retaining levers.

When fully seated, the replacement controller restarts automatically—the reset LED turns ON.

The following display appears:

If the other controller did not restart, follow these steps:

1. Press and hold the other controller's reset button.
2. Reseat the other controller's program card.
3. Release the reset button.

Press return to continue.

15. Press **Enter/Return** to continue. FRUTIL will exit.

If the “other controller” did not restart, follow these steps:

- a. Press and hold the “other controller” reset button.
- b. Reseat the “other controller” program card.
- c. Release the reset button.

NOTE: In mirrored mode, FRUTIL initializes the mirrored portion of the new cache module, checks for old data on the cache module, then restarts all device ports. After the device ports restart, FRUTIL tests the cache module and the ECB. After the test completes, the device ports are quiesced and a mirror copy of the cache module data is created on the newly installed cache module.

16. Replace the program card ESD cover.

17. Connect all host bus cables to the new controller.

NOTE: If the controller being installed was previously used in another subsystem, it will need to be purged of the old configuration (see CONFIG RESET in the *Compaq StorageWorks HSG80 Array Controller ACS Version 8.5 CLI Reference Guide*).

18. Enable failover and re-establish the dual-redundant controller configuration with the following command:

```
SET FAILOVER COPY=THIS_CONTROLLER
```

This command copies the subsystem configuration from “this controller” to the new controller.

19. See the *Compaq StorageWorks HSG80 Array Controller ACS Version 8.5 CLI Reference Guide* to configure the controller.

20. Disconnect the PC or terminal from the controller maintenance port.

Replacing a Controller in a Dual-Redundant Controller Configuration

Use the following steps in “Removing a Controller in a Dual-Redundant Controller Configuration” and “Installing a Controller in a Dual-Redundant Controller Configuration” to replace a controller.

Removing a Controller in a Dual-Redundant Controller Configuration

Use the following steps to remove a controller.

1. Connect a PC or terminal to the maintenance port of the operational controller.
The controller connected to becomes “this controller;” the controller being removed becomes the “other controller.”
2. Disable failover and take the controllers out of their dual-redundant configuration with the following command:

```
SET NOFAILOVER
```
3. Remove the program card ESD cover and program card from the “other controller.” Save them in a static-free place for the replacement controller.
4. Start FRUTIL with the following command:

```
RUN FRUTIL
```

The following display appears:

Do you intend to replace this controller's cache battery? Y/N

5. Enter **N(o)**. The following menu appears:

FRUTIL Main Menu:

1. Replace or remove a controller or cache module
2. Install a controller or cache module
3. Replace a PVA module
4. Replace an I/O module
5. Exit

Enter choice: 1, 2, 3, 4, or 5 ->

6. Enter option 1. The following menu appears:

Replace or remove Options:

1. Other controller and cache module
2. Other controller module
3. Other cache module
4. Exit

Enter choice: 1, 2, 3, or 4 ->

7. Enter option 2. The following display appears:

Slot Designations

(front view)

```
[ --- EMU --- ][ --- PVA --- ]
[ ----- Controller A ----- ]
[ ----- Controller B ----- ]
[ Cache Module A ][ Cache Module B ]
```

Remove the slot A [or B] controller? Y/N

8. Type **Y(es)**. The following display appears:

```
Quiescing all device ports. Please wait...
  Device Port 1 quiesced.
  Device Port 2 quiesced.
  Device Port 3 quiesced.
  Device Port 4 quiesced.
  Device Port 5 quiesced.
  Device Port 6 quiesced.
All device ports quiesced.
Remove the slot A [or B] controller (the one without a blinking green
LED) within 2 minutes.
```



CAUTION: The device ports must quiesce before removing the controller. Failure to allow the ports to quiesce might result in data loss. Quiescing might take several minutes.

ESD can easily damage a controller. Wear a snug-fitting, grounded ESD wrist strap.

NOTE: A countdown timer allows a total of 2 minutes to remove the controller. After 2 minutes, “this controller” will exit FRUTIL and resume operations. If this happens, return to step 4 and proceed.

9. Remove all host bus cables from the “other controller” using needle-nose pliers (see inset on Figure 3-6).
10. Disengage both retaining levers, remove the “other controller,” and place the controller into an antistatic bag or onto a grounded antistatic mat.

Once the controller is removed, The following display appears:

```
Restarting all device ports. Please wait...
  Device Port 1 restarted.
  Device Port 2 restarted.
  Device Port 3 restarted.
  Device Port 4 restarted.
  Device Port 5 restarted.
  Device Port 6 restarted.
Do you have a replacement controller? Y/N
```

11. Enter **N(o)** if a replacement controller is not available.

- FRUTIL will exit.

- Disconnect the PC or terminal from the controller maintenance port.

Enter **Y(es)** if a replacement controller is available and it will be installed now. The following display appears:

```
Insert the slot A [or B] controller? Y/N
```

NOTE: If you entered Y(es) go to step 6 on page 3-23 and proceed.

Installing a Controller in a Dual-Redundant Controller Configuration

Use the following steps to install a controller.

1. Connect a PC or terminal to the maintenance port of the operational controller.

The controller connected to becomes “this controller;” the controller being installed becomes the “other controller.”

2. Start FRUTIL with the following command:

```
RUN FRUTIL
```

The following display appears:

```
Do you intend to replace this controller's cache battery? Y/N
```

3. Enter **N(o)**. The following menu appears:

```
FRUTIL Main Menu:
```

1. Replace or remove a controller or cache module
2. Install a controller or cache module
3. Replace a PVA module
4. Replace an I/O module
5. Exit

```
Enter choice: 1, 2, 3, 4, or 5 ->
```

4. Enter option 2. The following menu appears:

```
Install Options:
```

1. Other controller and cache module
2. Other controller module
3. Other cache module
4. Exit

```
Enter choice: 1, 2, 3, or 4 ->
```

5. Enter option 2. The following display appears:

```
Insert the slot A [or B] controller? Y/N
```

6. Enter **Y**(es). The following display appears:

```
Quiescing all device ports. Please wait...
```

```
Device Port 1 quiesced.
```

```
Device Port 2 quiesced.
```

```
Device Port 3 quiesced.
```

```
Device Port 4 quiesced.
```

```
Device Port 5 quiesced.
```

```
Device Port 6 quiesced.
```

```
All device ports quiesced.
```

```
.
```

```
.
```

```
.
```

```
Insert the controller module, WITH its program card, in slot A [or B]  
within x minutes, xx seconds.
```

NOTE: A countdown timer allows a total of 2 minutes to install the controller. After 2 minutes, “this controller” will exit FRUTIL and resume operations. If this happens, return to step 2 and proceed.



CAUTION: ESD can easily damage a controller. Wear a snug-fitting, grounded ESD wrist strap.

Carefully align the controller in the appropriate guide rails. Misalignment might damage the backplane.

7. Make sure that the program card is seated in the replacement controller, insert the controller into its bay, and engage its retaining levers.

When fully seated, the newly installed controller restarts automatically.

The following display appears:

```
If the other controller did not restart, follow these steps:
```

```
1. Press and hold the other controller's reset button.
```

```
2. Reseat the other controller's program card.
```

```
3. Release the reset button.
```

```
Press return to continue.
```

8. Press **Enter/Return** to continue. FRUTIL will exit.

If the “other controller” did not restart, follow these steps:

- a. Press and hold the “other controller” reset button.
 - b. Reseat the “other controller” program card.
 - c. Release the reset button.
9. Replace the program card ESD cover.
 10. Connect all host bus cables to the new controller.

NOTE: If the controller being installed was previously used in another subsystem, it will need to be purged of the old configuration (see CONFIG RESET in the *Compaq StorageWorks HSG80 Array Controller ACS Version 8.5 CLI Reference Guide*).

11. Enable failover and re-establish the dual-redundant controller configuration with the following command:

```
SET FAILOVER COPY=THIS_CONTROLLER
```

This command copies the subsystem configuration from “this controller” to the new controller.

12. See the *Compaq StorageWorks HSG80 Array Controller ACS Version 8.5 CLI Reference Guide* to configure the controller.
13. Disconnect the PC or terminal from the controller maintenance port.

Replacing a Cache Module in a Dual-Redundant Controller Configuration

Use the following steps in “Removing a Cache Module in a Dual-Redundant Controller Configuration” and “Installing a Cache Module in a Dual-Redundant Controller Configuration” to replace a cache module.

NOTE: The new cache module *must* contain the same memory configuration as the cache module being replaced.

Removing a Cache Module in a Dual-Redundant Controller Configuration

Use the following steps to remove a cache module.

1. Connect a PC or terminal to the maintenance port of the operational controller.

The controller connected to becomes “this controller;” the controller for the cache module being removed becomes the “other controller.”

2. Disable failover and take the controllers out of their dual-redundant configuration with the following command:

```
SET NOFAILOVER
```

3. Start FRUTIL with the following command:

```
RUN FRUTIL
```

The following display appears:

```
Do you intend to replace this controller's cache battery? Y/N
```

4. Enter **N(o)**. The following menu appears:

```
FRUTIL Main Menu:
```

1. Replace or remove a controller or cache module
2. Install a controller or cache module
3. Replace a PVA module
4. Replace an I/O module
5. Exit

```
Enter choice: 1, 2, 3, 4, or 5 ->
```

5. Enter option 1. The following menu appears:

```
Replace or remove Options:
```

1. Other controller and cache module
2. Other controller module
3. Other cache module
4. Exit

```
Enter choice: 1, 2, 3, or 4 ->
```

6. Enter option 3. The following display appears:

```
Slot Designations
```

```
(front view)
```

```
[ --- EMU --- ][ --- PVA --- ]  
[ ----- Controller A ----- ]  
[ ----- Controller B ----- ]  
[ Cache Module A ][ Cache Module B ]
```

```
Remove the slot A [or B] cache module? Y/N
```

7. Enter **Y(es)**. The following display appears:

```
Quiescing all device ports. Please wait...
```

```
Device Port 1 quiesced.
```

```
Device Port 2 quiesced.
```

```
Device Port 3 quiesced.
```

```
Device Port 4 quiesced.
```

```
Device Port 5 quiesced.
```

```
Device Port 6 quiesced.
```

```
All device ports quiesced.
```

```
Remove the slot A [or B] cache module within 2 minutes. Then disconnect  
the external battery from the cache module.
```



CAUTION: The device ports must quiesce before removing the cache module. Failure to allow the ports to quiesce might result in data loss. Quiescing might take several minutes.

ESD can easily damage the cache module or a DIMM. Wear a snug-fitting, grounded ESD wrist strap.

NOTE: A countdown timer allows a total of 2 minutes to remove the cache module. After 2 minutes, “this controller” will exit FRUTIL and resume operations. If this happens, return to step 3 and proceed.

8. Disengage both retaining levers and partially remove the “other controller” cache module—about half way.



CAUTION: The ECB must be disabled—the status light is not lit and is not blinking—before disconnecting the ECB cable from the cache module. Failure to disable the ECB might result in cache module damage.

9. Disable the ECB by pressing the battery disable switch until the status light stops blinking—approximately 5 seconds.
10. Disconnect the ECB cable from the “other controller” cache module, remove the cache module, and place it onto a grounded antistatic mat or into an antistatic bag.

Once the cache module is removed, the following display appears:

```
Restarting all device ports. Please wait...  
Device Port 1 restarted.  
Device Port 2 restarted.  
Device Port 3 restarted.  
Device Port 4 restarted.  
Device Port 5 restarted.  
Device Port 6 restarted.  
Do you have a replacement cache module? Y/N
```

11. Enter **N(o)** if a replacement cache module is not available.

- FRUTIL will exit.
- Disconnect the PC or terminal from the controller maintenance port.

Enter **Y(es)** if a replacement controller and cache module is available and it will be installed now.

NOTE: Remove the DIMMs from the cache module for installation in the replacement cache module. Then go to step 6 on page 3-28 and proceed.

- a. Press the DIMM retaining clips down at both ends of the DIMM being removed.
- b. Gently remove the DIMM from the DIMM slot and place it onto an antistatic bag or grounded antistatic mat.
- c. Repeat step a and step b for each DIMM.

Installing a Cache Module in a Dual-Redundant Controller Configuration

Use the following steps to install a cache module.



CAUTION: ESD can easily damage a cache module or a DIMM. Wear a snug-fitting, grounded ESD wrist strap.

1. Connect a PC or terminal to the maintenance port of the operational controller.
The controller connected to becomes “this controller;” the controller for the cache module being installed becomes the “other controller.”

2. Start FRUTIL with the following command:

```
RUN FRUTIL
```

The following display appears:

```
Do you intend to replace this controller's cache battery? Y/N
```

3. Enter N(o). The following menu appears:

```
FRUTIL Main Menu:
```

1. Replace or remove a controller or cache module
2. Install a controller or cache module
3. Replace a PVA module
4. Replace an I/O module
5. Exit

```
Enter choice: 1, 2, 3, 4, or 5 ->
```

4. Enter option 2. The following menu appears:

```
Install Options:
```

1. Other controller and cache module
2. Other controller module
3. Other cache module
4. Exit

```
Enter choice: 1, 2, 3, or 4 ->
```

5. Enter option 3. The following display appears:

```
Insert the slot A [or B] cache module? Y/N
```

NOTE: Use the DIMMs that were removed from the old cache module for the replacement cache module.

6. Insert each DIMM straight into the appropriate slot of the cache module, ensuring that the notches in the DIMM align with the tabs in the slot (see Figure 2-6).
7. Press the DIMM gently into the slot until seated at both ends.
8. Engage two retaining clips for the DIMM.
9. Repeat step 6 through step 8 for each DIMM.

10. Enter **Y(es)**. The following display appears:

Quiescing all device ports. Please wait...

Device Port 1 quiesced.

Device Port 2 quiesced.

Device Port 3 quiesced.

Device Port 4 quiesced.

Device Port 5 quiesced.

Device Port 6 quiesced.

All device ports quiesced.

.
. .
.

Perform the following steps:

1. Turn off the battery for the new cache module by pressing the battery's shut off button for five seconds
2. Connect the battery to the new cache module.
3. Insert the new cache module in slot A [or B] within 2 minutes.

NOTE: A countdown timer allows a total of 2 minutes to install the cache module. After 2 minutes, "this controller" will exit FRUTIL and resume operations. If this happens, return to step 2 and proceed.



CAUTION: The ECB must be disabled—the status light is not lit and is not blinking—before disconnecting the ECB cable from the cache module. Failure to disable the ECB might damage the cache module.

11. Disable the ECB by pressing the battery disable switch until the status light stops blinking—approximately 5 seconds.

12. Connect the ECB cable to the new cache module.



CAUTION: Carefully align the cache module in the appropriate guide rails. Misalignment might damage the backplane.

13. Insert the new cache module into its bay and engage its retaining levers.

NOTE: In mirrored mode, FRUTIL initializes the mirrored portion of the new cache module, checks for old data on the cache module, then restarts all device ports. After the device ports restart, FRUTIL tests the cache module and the ECB. After the test completes, the device ports are quiesced and a mirror copy of the cache module data are created on the newly installed cache module.

FRUTIL restarts the “other controller.” The following display appears:

```
Please wait . . .
```

```
If the other controller did not restart, press its reset button.
```

```
Field Replacement Utility terminated.
```

14. If the “other controller” did not restart, press its reset button.
15. Enable failover and re-establish the dual-redundant configuration with the following command:

```
SET FAILOVER COPY=THIS_CONTROLLER
```

This command copies the subsystem configuration from “this controller” to the “other controller.”

16. Disconnect the PC or terminal from the controller maintenance port.

Replacing an ECB

The ECB can be replaced with cabinet power on or off. A dual ECB is shown in Figure 3-7 and contains two batteries. A single ECB contains only one battery.

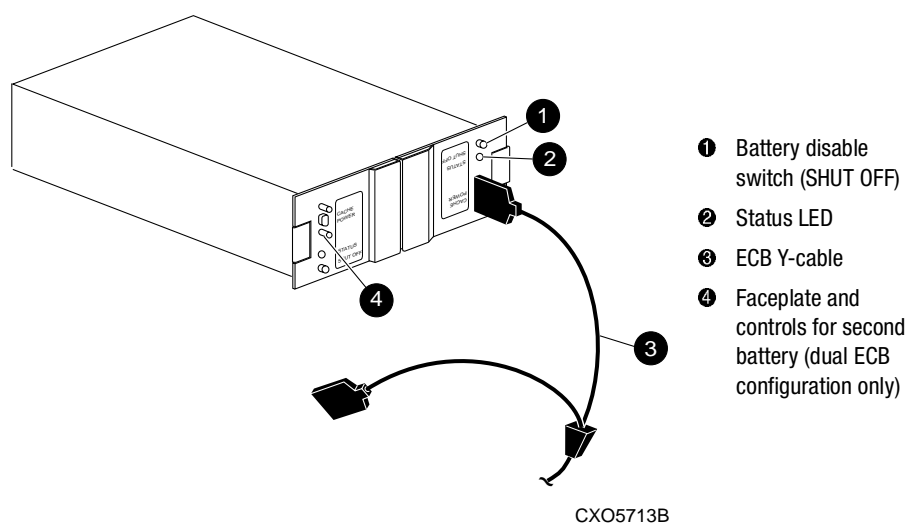

Figure 3-7. Dual ECB configuration

Replacing an ECB With the BA370 Subsystem Powered On

Use the following steps to replace the ECB with the BA370 subsystem powered on.

NOTE: The procedure for a dual-redundant controller configuration assumes that a single ECB with a dual battery is installed and an empty bay is available for the replacement ECB. If an empty bay is not available, place the new ECB on the top of the enclosure. After removing the old ECB, carefully insert the new ECB into the empty bay.

1. Connect a PC or terminal to the maintenance port of the controller with the ECB that needs replacement.

The controller connected to becomes “this controller;” the controller for the ECB cache module becomes the “other controller.”

2. Start FRUTIL with the following command:

```
RUN FRUTIL
```

The following display appears:

Do you intend to replace this controller's cache battery? Y/N

3. Enter **Y(es)**. The following display appears:

If the batteries were replaced while the cabinet was powered down, press return.

Otherwise follow this procedure:

WARNING: Ensure that at least one battery is connected to the Y cable at all times during this procedure.

1. Connect the new battery to the unused end of the 'Y' cable attached to cache A [or B].
2. Disconnect the old battery. Do not wait for the new battery's status light to turn solid green.
3. Press return.



CAUTION: The ECB cable has a 12-volt and a 5-volt pin. Improper handling or misalignment when connecting or disconnecting might cause these pins to contact ground, resulting in cache module damage.

4. Insert the new ECB into the empty battery bay.

NOTE: If an empty bay is not available, place the new ECB on the top of the enclosure.

IMPORTANT: Do not wait for the battery status light on the new ECB to turn solid green.

5. Connect the new ECB to the unused end of the Y-cable attached to cache A [or B] and disconnect the old ECB.

6. Press **Enter/Return**.

The following display appears:

Updating this battery's expiration date and deep discharge history.
Field Replacement Utility terminated.

7. Disconnect the PC or terminal from the controller maintenance port.

8. For a dual-redundant controller configuration with a dual ECB installed:
 - If the other cache module is also to be connected to the new ECB, connect the PC or terminal to the “other controller” maintenance port.
The connected controller now becomes “this controller.”
 - Repeat step 2 through step 7.
9. Remove the old ECB.

NOTE: If an empty bay was not available, and the new ECB was placed on the top of the enclosure, carefully insert it now into the empty bay.

Replacing an ECB With the BA370 Subsystem Powered Off

Use the following steps to replace the ECB with the BA370 subsystem powered off.

1. If the controller and cache module are not operating, go to step 4. Otherwise, proceed to step 2.
2. Connect a PC or terminal to the maintenance port of the operational controller.
The controller connected to becomes “this controller;” the controller for the ECB cache module becomes the “other controller.”
3. Shut down the controllers.
 - In single-controller configurations, shut down “this controller” with the following command:

```
SHUTDOWN THIS_CONTROLLER
```
 - In dual-redundant controller configurations, shut down the “other controller” first, then shut down “this controller” with the following commands:

```
SHUTDOWN OTHER_CONTROLLER  
SHUTDOWN THIS_CONTROLLER
```

When the controllers shut down, the reset buttons and the first three LEDs turn ON (see Figure 3-1). It might take several minutes for this indication to appear, depending on the amount of data that needs to be flushed from the cache modules.
4. Turn off the power to the subsystem.
5. Remove the old ECB if a single-ECB and insert the new ECB into its bay. For dual ECB configurations, do not remove until the end of the procedure.

NOTE: If an empty bay is not available, place the new ECB on the top of the enclosure.



CAUTION: The ECB cable has a 12-volt and a 5-volt pin. Improper handling or misalignment when connecting or disconnecting might cause these pins to contact ground, resulting in cache module damage.

6. Connect the open end of the ECB Y-cable to the new ECB and then disconnect the ECB cable from the old ECB.
7. Restore power to the subsystem. The controller automatically restarts.
8. Start FRUTIL with the following command:

RUN FRUTIL

The following display appears:

```
Do you intend to replace this controller's cache battery? Y/N
```

9. Type **Y(es)**. The following display appears:

```
If the batteries were replaced while the cabinet was powered  
down, press return.
```

```
Otherwise follow this procedure:
```

```
WARNING: Ensure that at least one battery is connected to the  
Y cable at all times during this procedure.
```

1. Connect the new battery to the unused end of the 'Y' cable attached to cache A [or B].
2. Disconnect the old battery. Do not wait for the new battery's status light to turn solid green.
3. Press return.

10. Press **Enter/Return**.

The following display appears:

```
Updating this battery's expiration date and deep discharge history.  
Field Replacement Utility terminated.
```

11. Disconnect the PC or terminal from the controller maintenance port.
12. For a dual-redundant controller configuration and the ECB was replaced for both cache modules:
 - If the other cache module is also to be connected to the new ECB, connect the PC or terminal to the “other controller” maintenance port.
The connected controller now becomes “this controller.”
 - Repeat step 8 through step 11.
 - Remove the old ECB.

Replacing a PVA Module

Use the following steps to replace a PVA module in the master enclosure (ID 0), the first expansion (ID 2), or second expansion enclosure (ID 3). The master enclosure contains the controllers and the cache modules.

NOTE: This procedure is not applicable for the M1 shelf.

The HSG80 controller can support up to three BA370 enclosures: a master enclosure and two expansion enclosures.

A PVA can be replaced in either a single-controller or a dual-redundant controller configuration using this procedure.

1. Connect a PC or terminal to the maintenance port of the operational controller.

The controller connected to becomes “this controller;” the second controller becomes the “other controller.”

2. In a dual-redundant controller configuration, disable failover with the following command:

```
SET NOFAILOVER
```

3. Start FRUTIL with the following command:

```
RUN FRUTIL
```

The following display appears:

```
Do you intend to replace this controller's cache battery? Y/N
```

4. Enter **N(o)**. The following menu appears:

```
FRUTIL Main Menu:
```

1. Replace or remove a controller or cache module
2. Install a controller or cache module
3. Replace a PVA module
4. Replace an I/O module
5. Exit

```
Enter choice: 1, 2, 3, 4, or 5 ->
```

5. Enter option 3. The following menu appears:

```
FRUTIL PVA Replacement Menu:
```

1. Master Enclosure (ID 0)
2. First Expansion Enclosure (ID 2)
3. Second Expansion Enclosure (ID 3)
4. Exit

```
Enter Choice: 1, 2, 3, or 4 ->
```

NOTE: The FRUTIL PVA Replacement Menu provides options for three enclosures regardless of how many enclosures are actually connected.

6. From the menu, select *one* of the following options:
 - Enter option 1 to replace the PVA in the master enclosure.
 - Enter option 2 to replace the PVA in the first expansion enclosure
 - Enter option 3 to replace the PVA in the second expansion enclosure.After selection, the following display appears:
Do you have a replacement PVA module? Y/N
7. Enter **Y(es)**. The following display appears:
Ensure the replacement PVA's address is set to zero [or 2 or 3].
Press return to quiesce device port activity.
8. Set the replacement PVA address (if needed, refer to the *Compaq StorageWorks UltraSCSI RAID Enclosure (BA370-Series) User Guide* for instructions):
 - To 0 for the master enclosure
 - To 2 for the first expansion enclosure
 - To 3 for the second expansion enclosure
9. Press **Enter/Return** and wait for FRUTIL to quiesce the device ports. This might take several minutes. The following display appears:
All device ports quiesced.
Replace the PVA in the master cabinet.
Press return to resume device port activity.
10. Disengage both retaining levers on the old PVA (see Figure 3-6, ⑦ on page 3-11) and remove it.



CAUTION: Carefully align the PVA in the appropriate guide rails. Misaligning the module might damage the backplane.

11. Insert the replacement PVA and engage both retaining levers.

12. Press **Enter/Return** to resume device port activity and restart the “other controller.”

When all port activity has restarted, The following display appears:

```
PVA replacement complete.
```

```
Please wait . . .
```

```
If the other controller did not restart, press its reset button.
```

```
Field Replacement Utility terminated.
```

13. If the “other controller” did not restart, press its reset button.
14. Enable failover and re-establish the dual-redundant configuration with the following command:

```
SET FAILOVER COPY=THIS_CONTROLLER
```

This command copies the subsystem’s configuration from “this controller” to the “other controller.”

15. Disconnect the PC or terminal from the controller maintenance port.

Replacing an EMU

Use the following steps in “Removing an EMU” and “Installing an EMU” to replace the EMU.



CAUTION: ESD can easily damage an EMU. Wear a snug-fitting, grounded ESD wrist strap.

Removing an EMU

Use the following steps to remove an EMU.

1. From a host console, stop all host activity and dismount the logical units in the subsystem. If using a Windows NT platform, shut down the server.
2. Connect a PC or terminal to the maintenance port of an operational controller.
3. Shut down the controllers.
 - In single-controller configurations, shut down “this controller” with the following command:

```
SHUTDOWN THIS_CONTROLLER
```

- In dual-redundant controller configurations, shut down the “other controller” first, then shut down “this controller” with the following commands:

```
SHUTDOWN OTHER_CONTROLLER
```

```
SHUTDOWN THIS_CONTROLLER
```

When the controllers shut down, the reset buttons and the first three LEDs turn ON (see Figure 3-1). It might take several minutes for this indication to appear, depending on the amount of data that needs to be flushed from the cache modules.

4. Turn OFF all AC input boxes for each enclosure (see Figure 1-1, ⑭).
5. Disengage both retaining levers and remove the EMU (see Figure 3-6, ① on page 3-11).

Installing an EMU

Use the following steps to install an EMU.



CAUTION: Carefully align the EMU in the appropriate guide rails. Misalignment might damage the backplane.

After installing the EMU, check the PVA SCSI ID number on the master enclosure to make sure it represents the correct enclosure number (ID 0). If the SCSI ID number is not 0, reset it to ID 0 before starting the controller.

1. Insert the EMU into its bay (see Figure 3-6, ① on page 3-11) and engage its retaining levers.
2. Verify that the master enclosure PVA SCSI ID number represents ID 0. If it is not 0, reset it to 0.
3. If there are no expansion enclosures, proceed to step 4.
If there are expansion enclosures, turn ON all AC input boxes for each expansion enclosure.
4. Turn ON all AC input boxes for the master enclosure (see Figure 1-1, ⑭).
5. If not already connected, connect a PC or terminal to the controller maintenance port.
6. Mount the logical units on the host. If using a Windows NT platform, restart the server.
7. Set the subsystem date and time using the following command in its entirety:

```
SET THIS_CONTROLLER TIME=dd-mmm-yyyy:hh:mm:ss
```
8. Disconnect the PC or terminal from the controller maintenance port.

Replacing an I/O Module

Figure 3-8 shows a rear view of the BA370 enclosure and the relative location of the six I/O modules (also referred to as ports). Figure 3-9 shows the six I/O modules and the location of the connectors and securing screws. Use the following steps to replace an I/O module.

NOTE: This procedure is not applicable for a DS-BA356-Mx-series enclosure.

An I/O module can be replaced in either a single-controller or a dual-redundant controller configuration using this procedure.

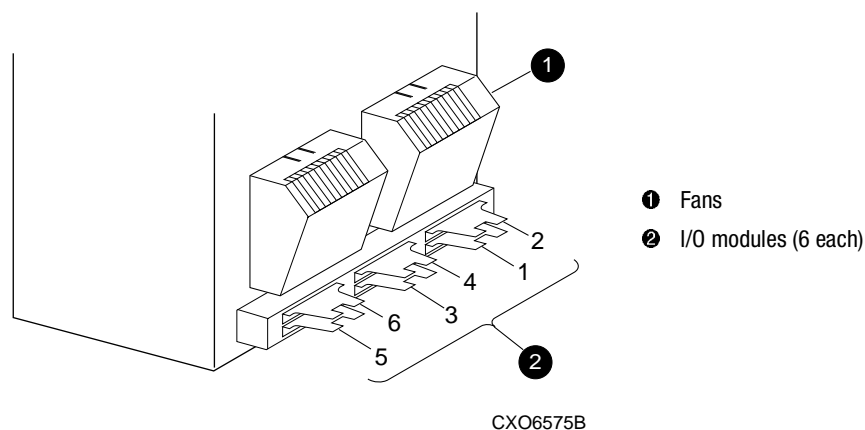

Figure 3-8. I/O module locations in a BA370 enclosure

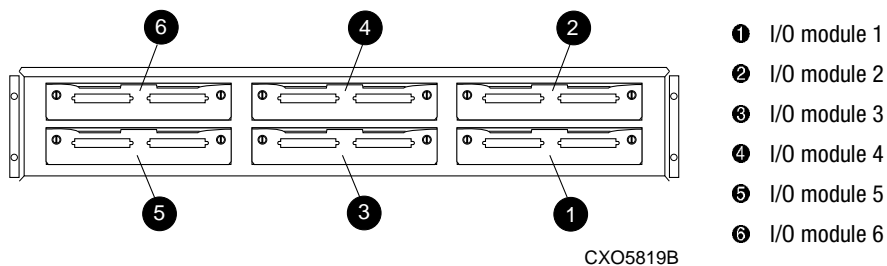

Figure 3-9. I/O module locations

NOTE: The controller can function with one failed I/O module.

1. Connect a PC or terminal to the maintenance port of an operational controller.
2. In a dual-redundant controller configuration, disable failover with the following command:

```
SET NOFAILOVER
```

3. Start FRUTIL with the following command:

```
RUN FRUTIL
```

The following display appears:

```
Do you intend to replace this controller's cache battery? Y/N
```

4. Enter **N(o)**. The following menu appears:

```
FRUTIL Main Menu:
```

1. Replace or remove a controller or cache module
2. Install a controller or cache module
3. Replace a PVA module
4. Replace an I/O module
5. Exit

```
Enter choice: 1, 2, 3, 4, or 5 ->
```

NOTE: The HSG80 controller supports up to three enclosures. The I/O Module status can show the following states:

- Single Ended – OK
- Differential – OK
- Termination only – OK
- Missing or bad
- Unknown or bad
- N/A (cabinet is not present)

5. Enter option 4. The following display appears (in the following example, cabinet 0, port 5 is missing or bad):

```

I/O Module Status:
      Cabinet 0          Cabinet 2          Cabinet 3
      -----          -----          -----
Port 1: Single Ended - OK   N/A          N/A
Port 2: Single Ended - OK   N/A          N/A
Port 3: Single Ended - OK   N/A          N/A
Port 4: Single Ended - OK   N/A          N/A
Port 5: Missing or bad     N/A          N/A
Port 6: Single Ended - OK   N/A          N/A

Is the replacement I/O module available? Y/N
    
```

6. Enter **Y(es)**.
7. Wait for FRUTIL to quiesce the device ports. After the ports have been quiesced (this might take several minutes), the following display appears:

```

All device ports quiesced.

Press return when the new I/O module is installed.
    
```



CAUTION: If you remove the incorrect module, the controller will crash.

8. Disconnect all cables from the appropriate I/O module.
9. Remove the failed I/O module (see Figure 3-9).
10. Install a replacement I/O module.
11. Reconnect all cables to the I/O module.
12. Press **Enter/Return** to resume device port activity and restart the “other controller.” When all port activity has restarted, the following display appears:

```

I/O module replacement complete.
    
```

```

Please wait . . .
    
```

```

If the other controller did not restart, press its reset button.
    
```

13. If the “other controller” did not restart, press its reset button.

14. Enable failover and re-establish the dual-redundant configuration with the following command:

```
SET FAILOVER COPY=THIS_CONTROLLER
```

This command copies the subsystem configuration from “this controller” to the “other controller.”

15. Disconnect the PC or terminal from the controller maintenance port.

Chapter 4

Replacement Procedures for Model 2200 Enclosure Elements

This chapter provides procedures for shutting down and restarting the subsystem and procedures for replacing the following Model 2200 enclosure elements:

- Array controller
- Cache module
- ECB
- I/O module

See enclosure documentation for information about replacing power supplies, cooling fans, bus cables, and power cables.

Shutting Down the Subsystem

Use the following steps to shut down a subsystem.

1. From a host console, stop all host activity and dismount the logical units in the subsystem. If using a Microsoft Windows NT platform, shut down the server.
2. Connect a PC or terminal to the maintenance port of one of the controllers in the subsystem.
3. Shut down the controllers.
 - In single-controller configurations, shut down “this controller” with the following command:

```
SHUTDOWN THIS_CONTROLLER
```

- In dual-redundant controller configurations, shut down the “other controller” first, then shut down “this controller” with the following commands:

```
SHUTDOWN OTHER_CONTROLLER
```

```
SHUTDOWN THIS_CONTROLLER
```

When the controllers shut down, the reset buttons and the first three LEDs turn ON (see Figure 4-1). It might take several minutes for this indication to appear, depending on the amount of data that needs to be flushed from the cache modules.

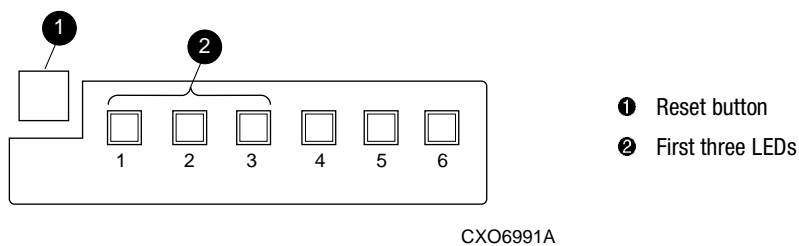

Figure 4-1. Controller reset button and first three LEDs

4. Remove power to the subsystem.



CAUTION: If shutting down the controller for longer than one day, reseal each ECB to stop its fault LED from FLASHING and prevent the ECB battery from discharging.

Restarting the Subsystem

Use the following steps to restart a subsystem.

1. Refer to enclosure documentation for specific procedures to follow for restarting the subsystem.

Once power is applied to the subsystem, the controllers automatically restart and the ECBs are automatically “re-enable” to provide backup power to the cache modules.

2. Mount the logical units on the host. If using a Windows NT platform, restart the server.

Replacing Controller and Cache Modules in a Single-Controller Configuration

Follow the instructions in this section to replace modules in a single-controller configuration (see Figure 4-2). To upgrade a single-controller configuration to a dual-redundant controller configuration, see Chapter 5.

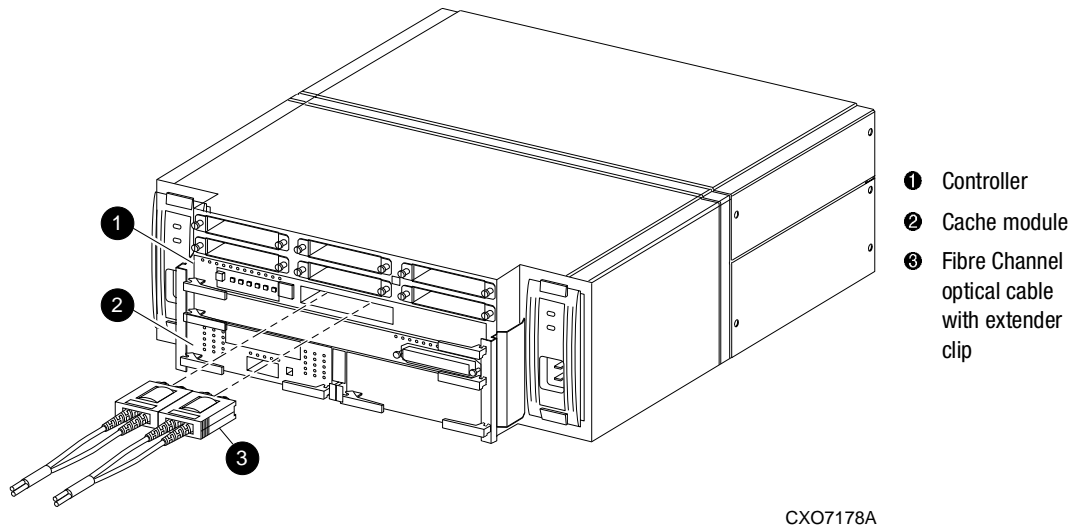

Figure 4-2. Single-controller configuration

The following sections contain procedures that replace both the controller and cache module, replace only the controller, and replace only the cache module.



CAUTION: In a single-controller configuration, always shut down the subsystem before removing or replacing any modules. Otherwise, data loss might occur.

For Fibre Channel optical cables without extender clips, the use of pliers is necessary to remove the cable from the controller without potentially damaging the cable.

IMPORTANT: For single-controller configurations, the only supported controller and cache module bays are Controller A and Cache A. *Do not* use Controller B and Cache B bays instead of Controller A and Cache A bays.

Replacing a Controller and Cache Module in a Single-Controller Configuration

If both the controller and cache module need to be replaced, first follow the steps for replacing a controller, and then the steps for replacing a cache module.

Replacing a Controller in a Single-Controller Configuration

Use the procedures in “Removing the Controller in a Single-Controller Configuration” and “Installing the Controller in a Single-Controller Configuration” to replace a controller.



CAUTION: ESD can easily damage a controller. Wear a snug-fitting, grounded ESD wrist strap.

Removing the Controller in a Single-Controller Configuration

Use the following steps to remove a controller.

1. From the host console, dismount the logical units in the subsystem. If using a Windows NT platform, shut down the server.
2. If the controller is operating, connect a PC or terminal to the controller maintenance port.
If the controller is not operating, go to step 6.
3. Run fault management utility (FMU) to obtain the last failure codes, if desired.
4. Is a disk initialized with the SAVE_CONFIGURATION switch?
 - Yes. Use the following command to save the current device configuration for “this controller:”

```
CONFIGURATION SAVE
```
 - No. Locate existing information that will support the manual configuration of the subsystem. The new controller must be manually configured as described in *Compaq StorageWorks HSG80 Array Controller ACS Version 8.5 CLI Reference Guide*.

5. Shut down the controller with the following command:

SHUTDOWN THIS_CONTROLLER

When the controller shuts down, the reset button and the first three LEDs turn ON (see Figure 4-1). It might take several minutes for this indication to appear, depending on the amount of data that needs to be flushed from the cache modules.



CAUTION: The cache module might contain unwritten data if the controller crashes and the controller cannot be shut down with the SHUTDOWN THIS_CONTROLLER command.

6. Remove the program card ESD cover and program card. Save them in a static-free place for the replacement controller.
7. Disconnect all host bus cables from the controller. For cables without extender clips, use needle nose pliers as shown in Figure 4-3 to disconnect a cable.

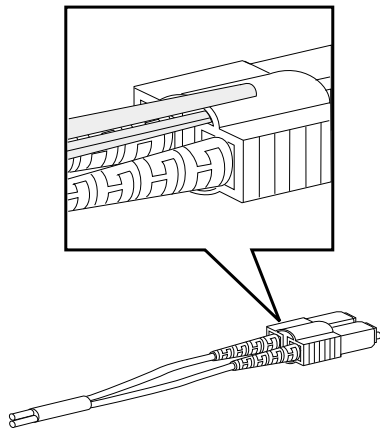

CXO6613A

Figure 4-3. Using pliers to disconnect an optical cable

8. If connected, disconnect the PC or terminal from the controller maintenance port.
9. Disengage both retaining levers and remove the controller.
10. Place the controller into an antistatic bag or onto a grounded antistatic mat.

Installing the Controller in a Single-Controller Configuration

Use the following steps to install a controller.



CAUTION: Carefully align the controller in the appropriate guide rails. Misaligning the module might damage the backplane.

1. Insert the new controller into its bay, and engage its retaining levers.
2. Connect all host bus cables to the new controller.
3. Connect a PC or terminal to the controller maintenance port.
4. Press and hold the reset button while inserting the program card into the new controller.
5. Release the reset button and replace the program card ESD cover.
6. When the CLI prompt reappears, display details about the configured controller using the following command:

```
SHOW THIS_CONTROLLER FULL
```

7. See the *Compaq StorageWorks HSG80 Array Controller ACS Version 8.5 CLI Reference Guide* to configure the controller.

NOTE: If the controller being installed was previously used in another subsystem, it will need to be purged of the old configuration (see CONFIG RESET in the *Compaq StorageWorks HSG80 Array Controller ACS Version 8.5 CLI Reference Guide*).

8. Does a disk contain the current device configuration saved on it?
 - Yes. Automatically restore the configuration as follows:

IMPORTANT: In the following step, hold the buttons until the Port Buttons start FLASHING, before releasing the two buttons.

- a. Press and hold the Port Button #6 (see Figure 4-4, ②) and then press and hold the reset buttons ① *until the port buttons start FLASHING.*

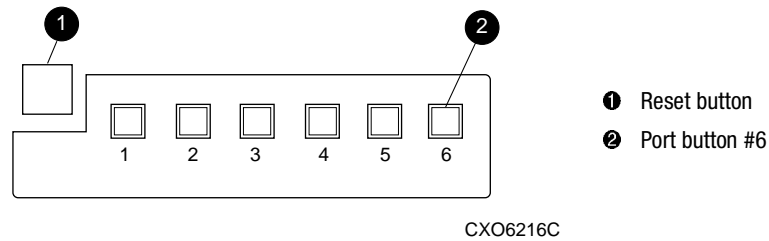

Figure 4-4. Location of array controller reset and port #6 buttons on the OCP

- b. Release the two buttons to initiate the configuration restore.
 - No. Manually restore the current device configuration using existing information and the *Compaq StorageWorks HSG80 Array Controller ACS Version 8.5 CLI Reference Guide*.
9. Using CLCP, install any patches that were installed on the previous controller (see Chapter 5).
10. Mount the logical units on the host. If using a Windows NT platform, restart the server.
11. Set the subsystem date and time using the following command in its entirety:

```
SET THIS_CONTROLLER TIME=dd-mmm-yyyy:hh:mm:ss
```
12. Disconnect the PC or terminal from the controller maintenance port.

Replacing a Cache Module in a Single-Controller Configuration

Use the following steps in “Removing the Cache Module in a Single-Controller Configuration” and “Installing the Cache Module in a Single-Controller Configuration” to replace a cache module.



CAUTION: ESD can easily damage a cache module or DIMM. Wear a snug-fitting, grounded ESD wrist strap.

Removing the Cache Module in a Single-Controller Configuration

Use the following steps to remove a cache module.

1. From the host console, dismount the logical units in the subsystem. If using a Windows NT platform, shut down the server.
2. If the controller is operating, connect a PC or terminal to the controller maintenance port.
If the controller is not operating, go to step 5.
3. Run FMU to obtain the last failure codes, if desired.
4. Shut down the controller with the following command:

```
SHUTDOWN THIS_CONTROLLER
```

When the controller shuts down, the reset button and the first three LEDs turn ON (see Figure 4-1). It might take several minutes for this indication to appear, depending on the amount of data that needs to be flushed from the cache modules.

5. Disengage both retaining levers, remove the cache module, and place the cache module into an antistatic bag or onto a grounded antistatic mat.

NOTE: Remove the DIMMs from the cache module for use within the replacement cache module.

6. Press down on the DIMM retaining clips at both ends of the DIMM being removed.
7. Gently remove the DIMM from the DIMM slot and place it onto an antistatic bag or grounded antistatic mat.
8. Repeat step 6 and step 7 for each DIMM.

Installing the Cache Module in a Single-Controller Configuration

Use the following steps to install the cache module.



CAUTION: Carefully align the cache module in the appropriate guide rails. Misaligning the module might damage the backplane.

1. Insert each DIMM straight into the appropriate slot of the new cache module, ensuring that the notches in the DIMM align with the tabs in the slot (see Figure 2-6).

2. Press the DIMM gently into the slot until seated at both ends.
3. Engage two retaining clips for the DIMM.
4. Repeat step 1 through step 3 for each DIMM.
5. Insert the new cache module into its bay and engage its retaining levers.
6. If not already connected, connect a PC or terminal to the controller maintenance port.
7. Restart the controller by pressing its reset button.
8. When the CLI prompt reappears, display details about the configured controller using the following command:

```
SHOW THIS_CONTROLLER FULL
```
9. Mount the logical units on the host. If using a Windows NT platform, restart the server.
10. Set the subsystem date and time using the following command in its entirety:

```
SET THIS_CONTROLLER TIME=dd-mmm-yyyy:hh:mm:ss
```
11. Disconnect the PC or terminal from the controller maintenance port.

Replacing Controller and Cache Modules in a Dual-Redundant Controller Configuration

Follow the instructions in this section to replace modules in a dual-redundant controller configuration (see Figure 4-5).

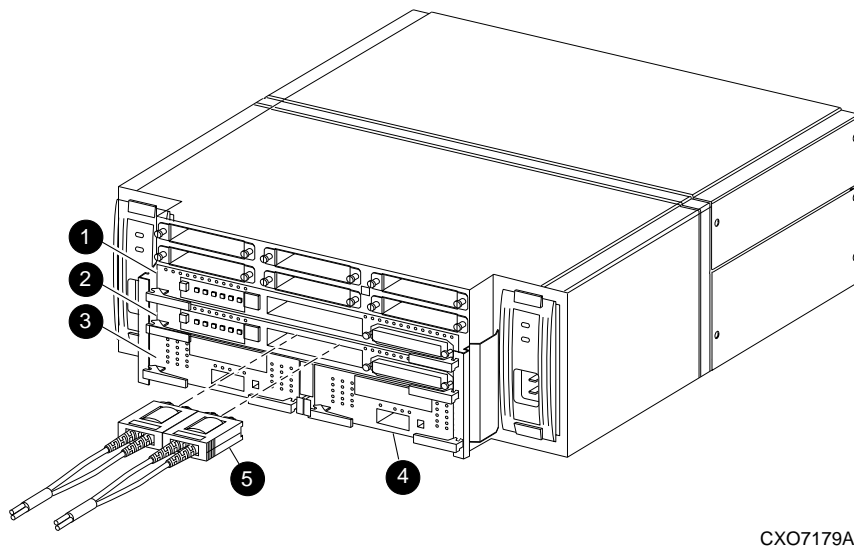

- | | |
|------------------|--|
| ❶ Controller A | ❷ Cache module B |
| ❸ Controller B | ❹ Fibre Channel optical cables with extender clips |
| ❺ Cache module A | |

Figure 4-5. Dual-redundant controller configuration

The following sections provide procedures for:

- Replacing both the controller and cache module
- Replacing a controller
- Replacing a cache module



CAUTION: For Fibre Channel optical cables without extender clips, the use of pliers is necessary to remove the cable from the controller without potentially damaging the cable.

IMPORTANT: Note the following before starting the replacement procedures:

- The new controller hardware must be compatible with the remaining controller hardware. See the product-specific release notes that accompanied the software release for information regarding hardware compatibility.
 - The software versions and patch levels must be the same on both controllers.
 - The new cache module must contain the same memory configuration as the module being replaced.
-

Replacing a Controller and Cache Module in a Dual-Redundant Controller Configuration

Use the following steps in “Removing a Controller and Cache Module in a Dual-Redundant Controller Configuration” and “Installing a Controller and its Cache Module in a Dual-Redundant Controller Configuration” to replace a controller and its cache module.



CAUTION: ESD can easily damage a controller, cache module, or DIMM. Wear a snug-fitting, grounded ESD wrist strap.

Both cache modules *must* contain the same cache memory configuration.

Removing a Controller and Cache Module in a Dual-Redundant Controller Configuration

Use the following steps to remove a controller and its cache module.

1. Connect a PC or terminal to the maintenance port of the operational controller.
The controller connected to becomes “this controller;” the controller being removed becomes the “other controller.”
2. Disable failover with the following command:

```
SET NOFAILOVER
```
3. Remove the program card ESD cover and program card from the “other controller.” Save them in a static-free place for the replacement controller.
4. Start field replacement utility (FRUTIL) with the following command:

```
RUN FRUTIL
```

Follow the on-screen instructions to remove the elements.



CAUTION: The device ports must quiesce before removing the controller. Failure to allow the ports to quiesce might result in data loss. Quiescing might take several minutes.

NOTE: A countdown timer allows a total of 4 minutes to remove both the controller and cache module. After 4 minutes, “this controller” exits FRUTIL and resumes operations. If this happens, return to step 4 and proceed.

IMPORTANT: When instructed to remove the controller and cache module, use following steps:

- a. Disconnect all host bus cables from the controller. For cables without extender clips, use needle nose pliers as shown in Figure 4-3 to disconnect each cable.
 - b. Disengage both retaining levers and remove the “other controller,” then place the controller into an antistatic bag or onto a grounded antistatic mat.
 - c. Disengage both retaining levers, remove the “other controller” cache module, and place it onto a grounded antistatic mat or into an antistatic bag.
-

5. Is a replacement controller and cache module available now?
 - If no, enter **N(o)**.
 - FRUTIL will exit.
 - Disconnect the PC or terminal from the controller maintenance port.
 - If yes, remove the DIMMs from the cache module for installation in the replacement cache module.
 - a. Press the DIMM retaining clips down at both ends of the DIMM being removed.
 - b. Gently remove the DIMM from the DIMM slot and place it onto an antistatic bag or grounded antistatic mat.
 - c. Repeat step a and step b for each DIMM.
 - d. Insert each DIMM straight into the appropriate slot of the cache module, ensuring that the notches in the DIMM align with the tabs in the slot (see Figure 2-6).
 - e. Press the DIMM gently into the slot until seated at both ends.
 - f. Engage two retaining clips for the DIMM.
 - g. Repeat step d through step f for each DIMM.
 - h. Enter **Y(es)**.

- i. Go to step 7 on page 4-13.

Installing a Controller and its Cache Module in a Dual-Redundant Controller Configuration

Use the following steps to install a controller and its cache module.



CAUTION: ESD can easily damage a controller, cache module, or DIMM. Wear a snug-fitting, grounded ESD wrist strap.

1. Insert each DIMM straight into the appropriate slot of the replacement cache module, ensuring that the notches in the DIMM align with the tabs in the slot (see Figure 2-6).
2. Press the DIMM gently into the slot until seated at both ends.
3. Engage two retaining clips for the DIMM.
4. Repeat step 1 through step 3 for each DIMM.
5. Connect a PC or terminal to the maintenance port of the operational controller.
The controller connected to becomes “this controller;” the controller being installed becomes the “other controller.”
6. Start FRUTIL with the following command:

```
RUN FRUTIL
```

Follow the on-screen instructions to install the elements.

NOTE: A countdown timer allows a total of 4 minutes to install both the cache module and controller. After 4 minutes, “this controller” will exit FRUTIL and resume operations. If this happens, return to step 6 and proceed.



CAUTION: Carefully align the cache module and controller in the appropriate guide rails. Misalignment might damage the backplane.

NOTE: When fully seated, the replacement controller restarts automatically—the reset LED turns On.

7. Press **Enter/Return** to continue.

The “other controller” restarts and FRUTIL exits.

NOTE: Restart indication is the temporary cycling of the port LEDs and a FLASHING reset button.

If the “other controller” did not restart, follow these steps:

- a. Press and hold the “other controller” reset button.
- b. Reseat the “other controller” program card.
- c. Release the reset button.

NOTE: In mirrored mode, FRUTIL initializes the mirrored portion of the new cache module, checks for old data on the cache module, then restarts all device ports. After the device ports restart, FRUTIL tests the cache module and the ECB. After the test completes, the device ports are quiesced and a mirror copy of the cache module data is created on the newly installed cache module.

8. Replace the program card ESD cover.
9. Connect all host bus cables to the new controller.

NOTE: If the controller being installed was previously used in another subsystem, it will need to be purged of the old configuration (see CONFIG RESET in the *Compaq StorageWorks HSG80 Array Controller ACS Version 8.5 CLI Reference Guide*).

10. Enable failover and re-establish the dual-redundant controller configuration with the following command:

```
SET FAILOVER COPY=THIS_CONTROLLER
```

This command copies the subsystem configuration from “this controller” to the new controller.

11. See the *Compaq StorageWorks HSG80 Array Controller ACS Version 8.5 CLI Reference Guide* to configure the controller.
12. Disconnect the PC or terminal from the controller maintenance port.

Replacing a Controller in a Dual-Redundant Controller Configuration

Use the following steps in “Removing a Controller in a Dual-Redundant Controller Configuration” and “Installing a Controller in a Dual-Redundant Controller Configuration” to replace a controller.

Removing a Controller in a Dual-Redundant Controller Configuration

Use the following steps to remove a controller.

1. Connect a PC or terminal to the maintenance port of the operational controller.

The controller connected to becomes “this controller;” the controller being removed becomes the “other controller.”

2. Disable failover and take the controllers out of their dual-redundant configuration with the following command:

```
SET NOFAILOVER
```

3. Remove the program card ESD cover and program card from the “other controller.” Save them in a static-free place for the replacement controller.
4. Start FRUTIL with the following command:

```
RUN FRUTIL
```

Follow the on-screen instructions to remove the controller.



CAUTION: The device ports must quiesce before removing the controller. Failure to allow the ports to quiesce might result in data loss. Quiescing might take several minutes.

ESD can easily damage a controller. Wear a snug-fitting, grounded ESD wrist strap.

NOTE: A countdown timer allows a total of 2 minutes to remove the controller. After 2 minutes, “this controller” will exit FRUTIL and resume operations. If this happens, return to step 4 and proceed.

IMPORTANT: When instructed to remove the “other controller,” use following steps:

- a. Disconnect all host bus cables from the “other controller.” For cables without extender clips, use needle nose pliers as shown in Figure 4-3 to disconnect each cable.
 - b. Disengage both retaining levers and remove the “other controller,” then place the controller into an antistatic bag or onto a grounded antistatic mat.
-

5. Is a replacement controller available now?

- If no, enter **N(o)**.
 - FRUTIL will exit.
 - Disconnect the PC or terminal from the controller maintenance port.
- If yes:
 - a. Enter **Y(es)**.
 - b. Follow on-screen instructions and go to step 3 on page 4-16.

NOTE: When fully seated, the replacement controller restarts automatically—the reset LED turns ON.

Installing a Controller in a Dual-Redundant Controller Configuration

Use the following steps to install a controller.

1. Connect a PC or terminal to the maintenance port of the operational controller.
The controller connected to becomes “this controller;” the controller being installed becomes the “other controller.”
2. Start FRUTIL with the following command:

```
RUN FRUTIL
```

Follow the on-screen instructions to install the controller.

NOTE: A countdown timer allows a total of 2 minutes to install the controller. After 2 minutes, “this controller” will exit FRUTIL and resume operations. If this happens, return to step 2 and proceed.



CAUTION: ESD can easily damage a controller. Wear a snug-fitting, grounded ESD wrist strap.

Carefully align the controller in the appropriate guide rails. Misalignment might damage the backplane.

NOTE: When fully seated, the replacement controller restarts automatically—the reset LED turns ON.

3. Press **Enter/Return** to continue.

The “other controller” restarts and FRUTIL exits.

NOTE: Restart indication is the temporary cycling of the port LEDs and a FLASHING reset button.

If the “other controller” did not restart, follow these steps:

- a. Press and hold the “other controller” reset button.
 - b. Reseat the “other controller” program card.
 - c. Release the reset button.
4. Replace the program card ESD cover.
 5. Connect all host bus cables to the new controller.

NOTE: If the controller being installed was previously used in another subsystem, it will need to be purged of the old configuration (see CONFIG RESET in the *Compaq StorageWorks HSG80 Array Controller ACS Version 8.5 CLI Reference Guide*).

6. Enable failover and re-establish the dual-redundant controller configuration with the following command:

```
SET FAILOVER COPY=THIS_CONTROLLER
```

This command copies the subsystem configuration from “this controller” to the new controller.

7. See the *Compaq StorageWorks HSG80 Array Controller ACS Version 8.5 CLI Reference Guide* to configure the controller.
8. Disconnect the PC or terminal from the controller maintenance port.

Replacing a Cache Module in a Dual-Redundant Controller Configuration

Use the following steps in “Removing a Cache Module in a Dual-Redundant Controller Configuration” and “Installing a Cache Module in a Dual-Redundant Controller Configuration” to replace a cache module.

NOTE: The new cache module *must* contain the same memory configuration as the cache module being replaced.

Removing a Cache Module in a Dual-Redundant Controller Configuration

Use the following steps to remove a cache module.

1. Connect a PC or terminal to the maintenance port of the operational controller.
The controller connected to becomes “this controller;” the controller for the cache module being removed becomes the “other controller.”
2. Disable failover and take the controllers out of their dual-redundant configuration with the following command:

```
SET NOFAILOVER
```

3. Start FRUTIL with the following command:

```
RUN FRUTIL
```

Follow the on-screen instructions to remove the cache module.



CAUTION: The device ports must quiesce before removing the cache module. Failure to allow the ports to quiesce might result in data loss. Quiescing might take several minutes.

ESD can easily damage the cache module or a DIMM. Wear a snug-fitting, grounded ESD wrist strap.

NOTE: A countdown timer allows a total of 2 minutes to remove the cache module. After 2 minutes, “this controller” will exit FRUTIL and resume operations. If this happens, return to step 3 and proceed.

IMPORTANT: When instructed to remove the cache module, use following steps:

- a. Disengage both retaining levers and partially remove the “other controller” cache module—about half way.
 - b. Disengage both retaining levers, remove the “other controller” cache module, and place it onto a grounded antistatic mat or into an antistatic bag.
-

4. Is a replacement cache module available now?

- If no, enter **N(o)**.
 - FRUTIL will exit.
 - Disconnect the PC or terminal from the controller maintenance port.
- If yes, remove the DIMMs from the cache module for installation in the replacement cache module.
 - a. Press the DIMM retaining clips down at both ends of the DIMM being removed.
 - b. Gently remove the DIMM from the DIMM slot and place it onto an antistatic bag or grounded antistatic mat.
 - c. Repeat step a and step b for each DIMM.
 - d. Insert each DIMM straight into the appropriate slot of the cache module, ensuring that the notches in the DIMM align with the tabs in the slot (see Figure 2-6).
 - e. Press the DIMM gently into the slot until seated at both ends.
 - f. Engage two retaining clips for the DIMM.
 - g. Repeat step d through step f for each DIMM.
 - h. Enter **Y(es)**.
 - i. Go to step 1 on page 4-19.

Installing a Cache Module in a Dual-Redundant Controller Configuration

Use the following steps to install a cache module.



CAUTION: ESD can easily damage a cache module or a DIMM. Wear a snug-fitting, grounded ESD wrist strap.

1. Insert each DIMM straight into the appropriate slot of the replacement cache module, ensuring that the notches in the DIMM align with the tabs in the slot (see Figure 2-6).
2. Press the DIMM gently into the slot until seated at both ends.
3. Engage two retaining clips for the DIMM.
4. Repeat step 1 through step 3 for each DIMM.
5. Connect a PC or terminal to the maintenance port of the operational controller.

The controller connected to becomes “this controller;” the controller for the cache module being installed becomes the “other controller.”

6. Start FRUTIL with the following command:

```
RUN FRUTIL
```

Follow the on-screen instructions to remove the cache module.

NOTE: A countdown timer allows a total of 2 minutes to install the cache module. After 2 minutes, “this controller” will exit FRUTIL and resume operations. If this happens, return to step 6 and proceed.



CAUTION: Carefully align the cache module in the appropriate guide rails. Misalignment might damage the backplane.

NOTE: In mirrored mode, FRUTIL initializes the mirrored portion of the new cache module, checks for old data on the cache module, then restarts all device ports. After the device ports restart, FRUTIL tests the cache module and the ECB. After the test completes, the device ports are quiesced and a mirror copy of the cache module data are created on the newly installed cache module.

NOTE: When the cache module is fully seated, FRUTIL restarts the “other controller” and then FRUTIL exits. Restart indication is the temporary cycling of the port LEDs and a FLASHING reset button.

7. If the “other controller” did not restart, press its reset button.

8. Enable failover and re-establish the dual-redundant configuration with the following command:

```
SET FAILOVER COPY=THIS_CONTROLLER
```

This command copies the subsystem configuration from “this controller” to the “other controller.”

9. Disconnect the PC or terminal from the controller maintenance port.

Replacing an ECB

Model 2200 enclosures contain four ECB bays. Two bays support cache module A (A1 and A2) and two bays support cache B (B1 and B2)—see the relationship in Figure 4-6. When replacing an ECB (see Figure 4-7), match the vacant ECB bay with the cache module it supports.

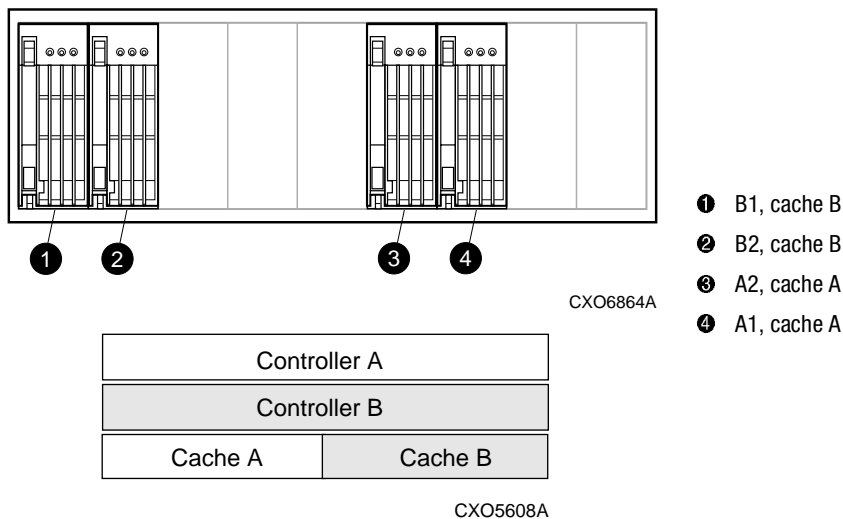

Figure 4-6. ECB and cache module locations in a Model 2200 enclosure

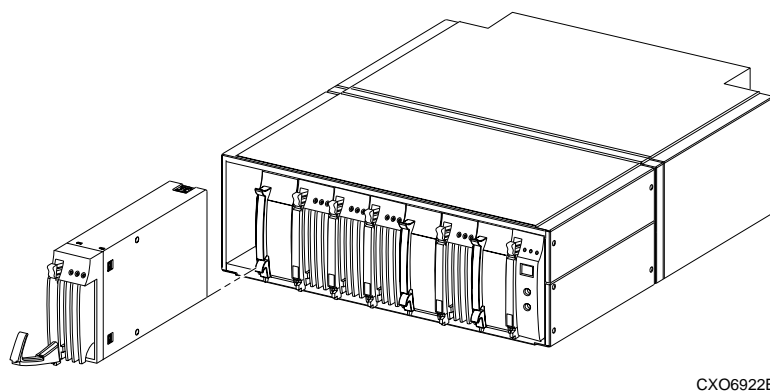

Figure 4-7. Removing an ECB that supports cache module B in a Model 2200 enclosure

Use the following steps to replace the ECB.

1. Connect a PC or terminal to the maintenance port of the controller with the ECB that needs replacement.

The controller connected to becomes “this controller;” the controller for the ECB cache module becomes the “other controller.”

2. Enter the following command to verify that system time is set:

```
SHOW THIS_CONTROLLER FULL
```

If system time is not set or current, enter the current time using the following command:

```
SET THIS_CONTROLLER TIME=dd-mmm-yyyy:hh:mm:ss
```

3. Start FRUTIL with the following command:

```
RUN FRUTIL
```

Follow the on-screen instructions to replace the ECB.



CAUTION: Make sure to install the replacement ECB in a bay that supports the same cache module as the current ECB being removed.

Remove the blank bezel from this replacement bay and reinstall the blank bezel in the bay vacated by the current ECB. Failure to reinstall the blank bezel might cause an overtemperature condition and damage the enclosure.

NOTE: Install a Battery Service Label on the replacement ECB prior to installing it in the enclosure. This label indicates the installation date (MM/YY) for the replacement ECB.

4. Disconnect the PC or terminal from the controller maintenance port.
5. Repeat step 1 and step 4 to replace another ECB for the “other controller” in a dual-redundant controller configuration.

Replacing an I/O Module

Figure 4-8 shows a rear view of the Model 2200 enclosure and the relative location of the six I/O modules (also referred to as ports), their connectors and securing screws.

Figure 4-9 shows the SCSI bus correlation for each I/O module.

NOTE: This procedure is not applicable for a DS-BA356-Mx-series enclosure.

An I/O module can be replaced in either a single-controller or a dual-redundant controller configuration using this procedure.

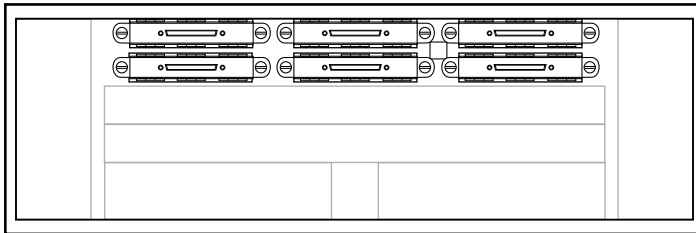

CXO7182A

Figure 4-8. I/O module locations in a Model 2200 enclosure

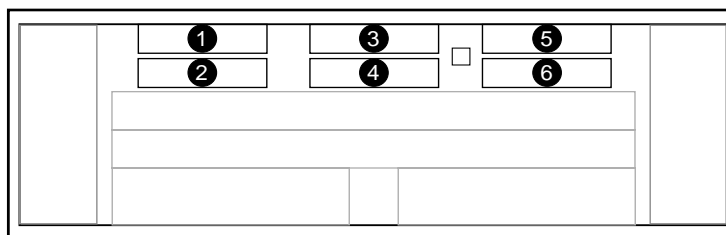

CXO7183A

- | | | | |
|-----------------------------|-----------------------------|-----------------------------|-----------------------------|
| ❶ I/O module and SCSI bus 1 | ❷ I/O module and SCSI bus 2 | ❸ I/O module and SCSI bus 3 | ❹ I/O module and SCSI bus 4 |
| ❺ I/O module and SCSI bus 5 | ❻ I/O module and SCSI bus 6 | | |

Figure 4-9. I/O module to SCSI bus numbering

NOTE: The controller can function with only one operational I/O module.

Use the following steps to replace any number of I/O modules.

1. Connect a PC or terminal to the maintenance port of an operational controller.
2. In a dual-redundant controller configuration, disable failover with the following command:

SET NOFAILOVER

3. Start FRUTIL with the following command:

RUN FRUTIL

Follow the on-screen instructions to replace any number of I/O modules in this enclosure.

IMPORTANT: When instructed to replace an I/O module, use following steps:

1. Disconnect the SCSI bus cable from the appropriate I/O modules (see Figure 4-9).
 2. Remove all failed I/O modules.
 3. Install all replacement I/O modules.
 4. Reconnect a SCSI bus cable to all replacement I/O modules.
-

5. Enable failover and re-establish the dual-redundant configuration with the following command:

```
SET FAILOVER COPY=THIS_CONTROLLER
```

This command copies the subsystem configuration from “this controller” to the “other controller.”

6. Disconnect the PC or terminal from the controller maintenance port.

Chapter 5

Upgrading the Subsystem

This chapter provides instructions for upgrading the controller software, installing software patches, upgrading firmware on a device, upgrading from a single-controller configuration to a dual-redundant controller configuration, and upgrading cache memory.

IMPORTANT: See Chapter 2 to review the list of required tools and the precautions to follow prior to performing any procedure within this chapter.

Upgrading Controller Software

Upgrade controller software using one of two ways:

- Install a new program card (see Figure 5-1) that contains the new software.
- Download a new software image, and use the menu-driven CLCP utility to write it onto the existing program card. Use this utility to also install, delete, and list patches to the controller software.

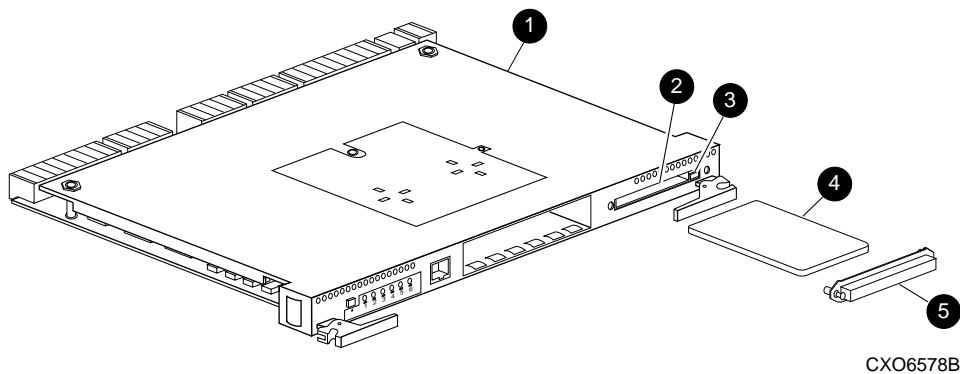

- | | | |
|--------------------------------|---------------------|--------------------------|
| ❶ Controller | ❷ Program card slot | ❹ Program (PCMCIA) card |
| ❸ Program card ejection button | | ❺ Program card ESD cover |

Figure 5-1. Program (PCMCIA) card

Installing a New Program Card

Use the following steps and Figure 5-1 to install a program (PCMCIA) card that contains the new software. If only upgrading the software in a single-controller configuration, disregard references to the “other controller.”

To upgrade the software by installing a new program card:

1. From the host console, dismount the storage units in the subsystem.
2. Connect a PC or terminal to the maintenance port of one of the controllers in the subsystem.

3. Shut down the controllers.

- In single-controller configurations, shut down “this controller” with the following command:

```
SHUTDOWN THIS_CONTROLLER
```

- In dual-redundant controller configurations, shut down the “other controller” first, then shut down “this controller” with the following commands:

```
SHUTDOWN OTHER_CONTROLLER
```

```
SHUTDOWN THIS_CONTROLLER
```

When the controllers shut down, the reset buttons and the first three LEDs turn ON (see Figure 5-2). It might take several minutes for this indication to appear, depending on the amount of data that needs to be flushed from the cache modules.



CAUTION: Do not change the subsystem configuration or replace any of its modules until this procedure for upgrading the controller software is completed.

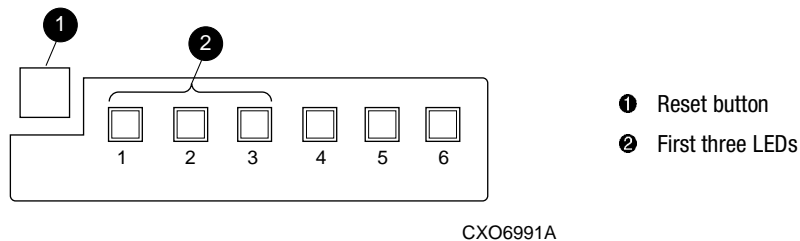

CXO6991A

Figure 5-2. Controller reset button and first three LEDs

4. Remove the program card ESD cover ⑤ on “this controller.”
5. Press and hold the reset button while ejecting the program card ④ from “this controller” by pressing the program card eject button ③.
6. Press and hold the reset button while inserting the replacement program card.
The “this controller” automatically restarts and is ready to handle I/O once the CLI becomes responsive.
7. Replace the program card ESD cover on “this controller.”
8. For BA370 enclosures only, verify that the master enclosure PVA SCSI ID number reads ID 0. If not, reset it to ID 0.

9. In a dual-redundant controller configuration, repeat step 4 through step 7 for the “other controller.”
10. Mount the storage units on the host.

Downloading New Software

Use the CLCP utility to download new software to the program card while installed in the controller. Use the following steps to upgrade the software with CLCP.

1. Obtain the new software image file from a customer service representative.

NOTE: The image file can also be loaded by using *StorageWorks* Command Console (SWCC) (see the SWCC documentation).

2. Load the image onto a PC or workstation using its file- or network-transfer capabilities.
3. From a host console, quiesce all port activity and dismount the storage units in the subsystem.

IMPORTANT: Do not remove the program card in the next step.

4. Remove the program card ESD cover.

If the program card is equipped with a write-protection switch (as shown in Figure 5-3), disable write-protection by sliding the switch to the “write” position.

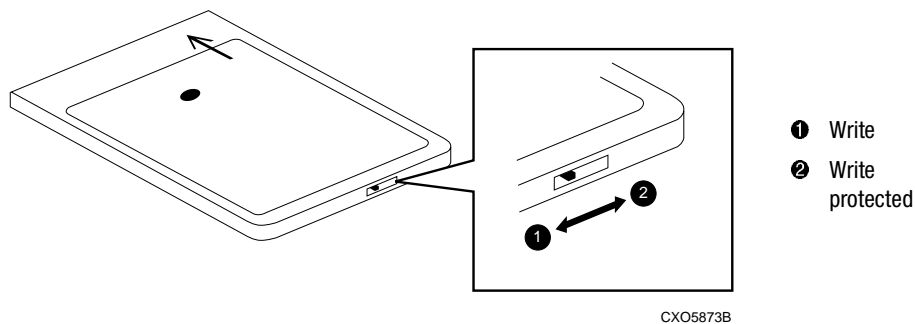

Figure 5-3. Location of write-protection switch

5. Connect a PC or terminal to the controller maintenance port.

6. Start CLCP with the following command:

RUN CLCP

The following menu appears:

```
Select an option from the following list:
Code Load & Patch local program Main Menu
0: Exit
1: Enter Code LOAD local program
2: Enter Code PATCH local program
3: Enter EMU Code LOAD Utility
Enter option number (0..3) [0] ?
```

7. Enter option 1. The following display appears:

You have selected the Code Load Utility. This utility is used to load a new software image into the program card currently inserted in the controller.

Type ^Y or ^C (then RETURN) at any time to abort code load.

The code image may be loaded using SCSI Write Buffer commands through the SCSI Host Port, or using KERMIT through the maintenance terminal port.

```
0: Exit
1: Use the SCSI Host Port
2: Use the Maintenance Terminal Port
Enter option number (0..2) [0] ?
```

NOTE: Use either the SCSI host port (if operating system supports it) or the maintenance port. To use the SCSI host port, go to step 8. To use the maintenance port, go to step 10.

8. Enter option 1. The following display appears:

```
WARNING: proceeding with Controller Code Load will overwrite
the current Controller code image with a new image.
Do you want to continue (y/n) [n]: ?
```

9. Enter **Y(es)** and the download starts.

When the download is complete, CLCP writes the new image to the program card and restarts the controller. This process takes one to 3 minutes. Go to step 15.

10. Enter option 2. The following display appears:

Perform the following steps before continuing:

- * get new image file on serial line host computer

- * configure KERMIT with the following parameters:

 - terminal speed 19200 baud, eight bit, no parity, 1 stop bit

It will take approximately 35 to 45 minutes to perform the code load operation.

WARNING: proceeding with Controller Code Load will overwrite

the current Controller code image with a new image.

Do you want to continue (y/n) [n]: ?

11. Enter **Y**(es). The following display appears:

Start KERMIT now...

12. Connect the PC to the controller maintenance port.
13. Configure the KERMIT transfer protocol on the PC to 19200 baud, eight bits, no parity, and one stop bit.
14. Use KERMIT to transfer the binary image from the PC to the controller.
When the download is complete, CLCP automatically writes the new image to the program card and restarts the controller.
15. Verify that the controller is running the new software version with the following command:

```
SHOW THIS CONTROLLER
```
16. If the program card is equipped with a write-protection switch (see Figure 5-3), enable write-protection by sliding the switch to the “write protected” position.
17. Replace the program card ESD cover.
18. Repeat the procedure to upgrade the “other controller” in dual-redundant controller subsystems.
19. Mount the storage units in the subsystem.

Using CLCP to Install, Delete, and List Software Patches

Use CLCP to manage software patches. These small programming changes are placed into the controller non-volatile memory and become active upon restarting the controller.

Keep the following points in mind while installing or deleting patches:

- Patches are associated with specific software versions. CLCP verifies the patch against the currently installed version.
- Patches are sequential: patch one must be entered before patch two, and so on.
- Deleting one patch also deletes all higher-numbered patches. For example, if deleting patch two, it also automatically deletes patches three, four, and so on.
- Controllers in a dual-redundant configuration must have the same patches. Install patches into each controller separately.

Installing a Software Patch

Use the following steps to install a software patch.

1. Obtain the patch file from a customer service representative or via the Internet at <http://www.storage.digital.com/menusupport.htm>.
2. Connect a PC or terminal to the controller maintenance port.
3. From the host console, quiesce all port activity.
4. Start CLCP with the following command:

```
RUN CLCP
```

The following menu appears:

```
Select an option from the following list:
Code Load & Patch local program Main Menu
0: Exit
1: Enter Code LOAD local program
2: Enter Code PATCH local program
3: Enter EMU Code LOAD utility
Enter option number (0..3) [0] ?
```

5. Enter option 2. The following menu appears:

You have selected the Code Patch local program. This program is used to manage software code patches. Select an option from the following list:

Type ^Y or ^C (then RETURN) at any time to abort Code Patch.

Code Patch Main Menu

- 0: Exit
- 1: Enter a Patch
- 2: Delete Patches
- 3: List Patches

Enter option number (0..3) [0] ?

6. Enter option 1. The following display appears:

This is the Enter a Code Patch option. The program prompts you for the patch information, one line at time. Be careful to enter the information exactly as it appears on the patch release. Patches may be installed for any version of software; however, patches entered for software versions other than XXXXX are not applied until the matching version of software is installed.

To enter any patch, you must first install all patches with lower patch numbers than the patch you are entering, beginning with patch number 1, for a specific software version. If you incorrectly enter the patch information, you are given the option to review the patch one line at a time.

Type ^Y or ^C (then RETURN) at any time to abort Code Patch.

Do you wish to continue (y/n) [y] ?

7. Enter **Y**(es) and follow the on-screen prompts.
8. After the patch is installed, press the controller reset button to restart the controller.
9. For dual-redundant controller configurations, repeat step 2 through step 8 for the second controller.

Deleting a Software Patch

Use the following steps to delete a software patch.

1. From a host console, quiesce all port activity.
2. Connect a PC or terminal to the controller maintenance port.
3. Start CLCP with the following command:

```
RUN CLCP
```

The following menu appears:

```
Select an option from the following list:
Code Load & Patch local program Main Menu
0: Exit
1: Enter Code LOAD local program
2: Enter Code PATCH local program
3: Enter EMU Code LOAD utility
Enter option number (0..3) [0] ?
```

4. Enter option 2. The following menu appears:

```
You have selected the Code Patch local program. This program is used to
manage software code patches. Select an option from the following list:
Type ^Y or ^C (then RETURN) at any time to abort Code Patch.
Code Patch Main Menu
    0: Exit
    1: Enter a Patch
    2: Delete Patches
    3: List Patches
Enter option number (0..3) [0] ?
```

5. Enter option 2. The following display appears:

```
This is the Delete Patches option. The program prompts you for the
software version and patch number you wish to delete. If you select a
patch for deletion that is required for another patch, all dependent
patches are also selected for deletion. The program lists your deletion
selections and asks if you wish to continue.
Type ^Y or ^C (then RETURN) at any time to abort Code Patch.
The following patches are currently stored in the patch area:
    Software Version - Patch number(s)
    xxxx                xxxx
Currently, xx% of the patch area is free.
Software Version of patch to delete?
```

6. Enter the software version of the patch to delete and press **Enter/Return**. The following display appears:

```
Patch Number to delete?
```

7. Enter the patch number to delete and press **Enter/Return**. The following display appears:

The following patches have been selected for deletion:

Software Version - Patch #

xxxx xxxx

Do you wish to continue (y/n) [n] ?

8. Enter **Y(es)** and the patches are deleted. The following menu appears:

Code Patch Main Menu

0: Exit

1: Enter a Patch

2: Delete Patches

3: List Patches

Enter option number (0..3) [0] ?

9. Enter option 0.
10. Press the controller reset button to restart the controller.
11. For dual-redundant controller configurations, repeat step 1 through step 10 for the second controller.

Listing Software Patches

Use the following steps to list software patches.

1. Connect a PC or terminal to the controller maintenance port.
2. Start CLCP with the following command:

```
RUN CLCP
```

The following menu appears:

Select an option from the following list:

Code Load & Patch local program Main Menu

0: Exit

1: Enter Code LOAD local program

2: Enter Code PATCH local program

3: Enter EMU Code LOAD utility

Enter option number (0..3) [0] ?

3. Enter option 2. The following menu appears:

You have selected the Code Patch local program. This program is used to manage software code patches. Select an option from the following list:
Type ^Y or ^C (then RETURN) at any time to abort Code Patch.

Code Patch Main Menu

- 0: Exit
- 1: Enter a Patch
- 2: Delete Patches
- 3: List Patches

Enter option number (0..3) [0] ?

4. Enter option 3. The following menu appears:

The following patches are currently stored in the patch area:

Software Version - Patch number(s)

xxxx xxxx

Code Patch Main Menu

- 0: Exit
- 1: Enter a Patch
- 2: Delete Patches
- 3: List Patches

Enter option number (0..3) [0] ?

5. Enter option 0.
6. For dual-redundant controller configurations, repeat step 1 through step 5 for the second controller.

Upgrading Firmware on a Device

Use the format and device code load utility (HSUTIL) to upgrade a device with firmware located in contiguous blocks at a specific logical block numbers (LBNs) on a source disk drive configured as a unit on the same controller. Upgrading firmware on a disk is a two-step process (see Figure 5-4).

1. Copy the new firmware from the host to a disk drive configured as a unit in the subsystem.
2. Use HSUTIL to load the firmware onto the devices in the subsystem.

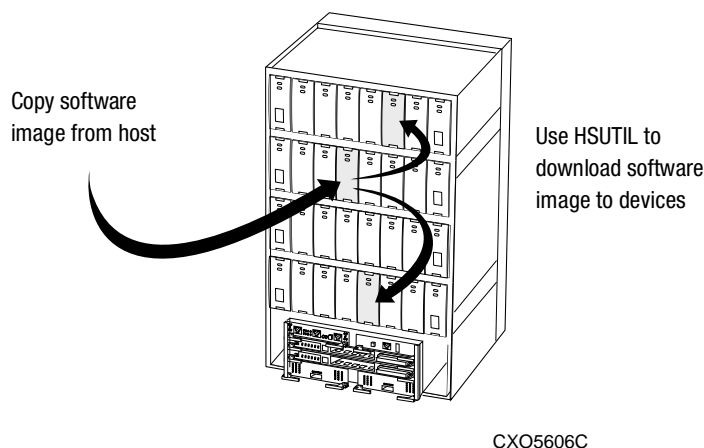

CXO5606C

Figure 5-4. Upgrading device firmware (BA370 enclosure example)

Keep the following points in mind while using HSUTIL to upgrade firmware on a device:

- HSUTIL has been tested with the qualified devices listed in the product-specific release notes that accompanied the software release. Firmware installed on unsupported devices is possible—HSUTIL will not prevent this—but if the upgrade fails, the device might be rendered unusable and therefore require the manufacturer's attention.
- If the power fails or the bus is reset while HSUTIL is installing the new firmware, the device might become unusable. To minimize this possibility, secure a reliable power source and suspend all I/O to the bus that services the device being upgraded.
- HSUTIL cannot install firmware on devices configured as single-disk drive units or as members of a storage set, spareset, or failedset. If installing firmware on a device previously configured as a single-disk drive, delete the unit number and storage set name associated with it.

- During the installation, the source disk drive is not available for other subsystem operations.
- Some devices might not reflect the new firmware version number when viewed from the “other controller” in a dual-redundant controller configuration. If this occurs, enter the following CLI command: `CLEAR_ERRORS device-name UNKNOWN`.
- Do not issue any CLI commands that access or inspect devices that are being formatted.

Use the following steps to upgrade firmware with HSUTIL.

1. Connect a PC or terminal to the controller maintenance port that accesses the device being upgraded.
2. Configure a single-disk unit.

NOTE: In the next steps, the firmware image is copied to this unit and HSUTIL is used to distribute it to the devices being upgraded. This unit must be a newly initialized disk with no label or file structure to ensure that the firmware image resides in contiguous blocks starting from LBN 0 or another known LBN. Additionally, write-back caching must be disabled (see *Compaq StorageWorks HSG80 Array Controller ACS Version 8.5 Configuration Guide*).

3. Copy the firmware image to the single-disk unit configured in step 2. The firmware image must begin at a known LBN—usually 0—and must be contiguous.

See the documentation that accompanied the host operating system for instructions on copying firmware images to a disk drive.



CAUTION: The host load must be quiesced before running HSUTIL; otherwise, damage to the storage device can occur.

4. Start HSUTIL with the following command:

```
RUN HSUTIL
```

The following menu appears:

```
HSUTIL Main Menu:
```

```
0. Exit
1. Disk Format
2. Disk Device Code Load
3. Tape Device Code Load
4. Disaster Tolerance Backend Controller Code Load
```

```
Enter function number: (0:4) [0]?
```

5. Enter option 2.

6. Choose the single-disk unit as the source disk for the download.
7. Enter the starting LBN of the firmware image—usually LBN 0.
8. Enter the product ID of the device being upgraded. This ID corresponds to the product information reported in the Type column when issuing a SHOW DISK FULL command.
HSUTIL lists all devices that correspond to the product ID entered.
9. Enter the disk or tape name of the device being upgraded.
10. Confirm or enter the byte count of the firmware image.
11. Confirm the download.
12. Some disk firmware releases require reformatting the disk after upgrading its firmware. See the documentation that accompanied the firmware to determine if device reformatting is required.
13. When HSUTIL finishes downloading the firmware, it displays the new firmware revision for the disk drive.

Upgrading to a Dual-Redundant Controller Configuration

Use the following steps to upgrade a single-controller configuration subsystem to a dual-redundant configuration subsystem. To replace failed components, see Chapter 3 or Chapter 4 for more information. Before beginning this procedure, obtain the following items:

- A second controller with the same software version and patch level as installed in the current single-controller
- A second cache module with the same memory configuration as installed in the current cache module
- A second ECB
- For BA370 enclosures only, a second ECB Y-cable

Use the following steps to install a second controller, cache module and ECB.



CAUTION: For BA370 enclosures only:

- After installing the controller, check the PVA SCSI ID number on the master enclosure to make sure it represents the correct enclosure number (ID 0).
 - If the SCSI ID number is not 0, reset it to ID 0 before starting the controller.
-

1. Connect a PC or terminal to the maintenance port of the operational controller.

The controller connected to becomes “this controller;” the controller being added becomes the “other controller.”

2. Start FRUTIL with the following command:

```
RUN FRUTIL
```

The following display appears:

```
Do you intend to replace this controller's cache battery? Y/N
```

3. Enter **N(o)**. The following menu appears:

FRUTIL Main Menu:

1. Replace or remove a controller or cache module
2. Install a controller or cache module
3. Replace a PVA module
4. Replace an I/O module
5. Exit

Enter choice: 1, 2, 3, 4, or 5 ->

4. Enter option 2. The following menu appears:

Install Options:

1. Other controller and cache module
2. Other controller module
3. Other cache module
4. Exit

Enter choice: 1, 2, 3, or 4 ->

5. Enter option 1. The following display appears:

Insert both the slot A [or B] controller and cache module? Y/N

6. Enter **Y(es)**. The following display appears:

Quiescing all device ports. Please wait...

Device Port 1 quiesced.

Device Port 2 quiesced.

Device Port 3 quiesced.

Device Port 4 quiesced.

Device Port 5 quiesced.

Device Port 6 quiesced.

All device ports quiesced.

.

.

.

BA370 enclosure display:

Perform the following steps:

1. Turn off the battery for the new cache module by pressing the battery's shut off button for five seconds.
2. Connect the battery to the new cache module.
3. Insert the new cache module in slot B within 4 minutes.

Model 2200 enclosure display:

Insert the new cache module in slot B within 4 minutes.

NOTE: A countdown timer allows a total of 4 minutes to install the controller and cache module. After 4 minutes, “this controller” will exit FRUTIL and resume operations. If this happens, return to step 2 and proceed.



CAUTION: ESD can easily damage a cache module or controller. Wear a snug-fitting, grounded ESD wrist strap.

7. Insert the new ECB:

■ For BA370 enclosures:

- a. Insert the ECB into an empty bay or on top of the enclosure.



CAUTION: The ECB must be disabled—the status light is not lit and is not blinking—before disconnecting the ECB cable from the cache module. Failure to disable the ECB might damage the cache module.

- b. Disable the ECB by pressing the battery disable switch until the status light stops blinking—approximately 5 seconds.
- c. Connect the new ECB cable to the new cache module.

■ For Model 2200 enclosures, insert the ECB into ECB bay B1 (see Figure 4-6).



CAUTION: Carefully align the cache module in the appropriate guide rails. Misalignment might damage the backplane.

8. Insert the new cache module into its bay and engage its retaining levers. The following display appears:

Insert the controller module, WITH its program card, in slot A [or B] within x minutes, xx seconds.

9. Make sure that the program card is in the new controller and insert the controller into its bay. Engage its retaining levers.

When fully seated, the newly installed controller will automatically restart. The following display appears:

If the other controller did not restart, follow these steps:

1. Press and hold the other controller's reset buttons.
2. Reseat the other controller's program card.
3. Release the reset button.

Press return to continue.

10. Press **Enter/Return** to continue.

If the "other controller" did not restart, follow these steps:

- a. Press and hold the "other controller" reset buttons.
- b. Reseat the "other controller" program card.
- c. Release the reset button.

11. Connect all host bus cables to the new controller.

NOTE: If the controller being installed was previously used in another subsystem, it will need to be purged of the old configuration (see CONFIG RESET in the *Compaq StorageWorks HSG80 Array Controller ACS Version 8.5 CLI Reference Guide*).

12. Enable failover, and establish the dual-redundant controller configuration with the following command:

```
SET FAILOVER COPY=THIS_CONTROLLER
```

This command copies the subsystem configuration from "this controller" to the new controller.

13. See the *Compaq StorageWorks HSG80 Array Controller ACS Version 8.5 CLI Reference Guide* to configure the controller.
14. Disconnect the PC or terminal from the controller maintenance port.

Upgrading Cache Memory

Use Figure 5-5 and Table 5-1 to configure the cache module.

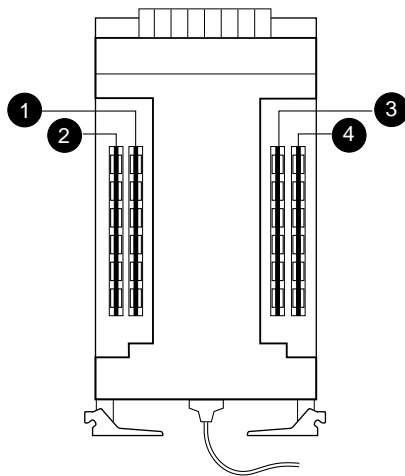

CXO6576B

Figure 5-5. Cache module DIMM locations

Table 5-1 Cache Module Memory Configurations

Memory	DIMMs	Quantity	Location
64 MB	32 MB	2	① ③
128 MB	32 MB	4	① ② ③ ④
256 MB	128 MB	2	① ③
512 MB	128 MB	4	① ② ③ ④

IMPORTANT: For ACS V8.5P installations, the required cache memory configuration is 512 MB. For ACS V8.5S, *Compaq* strongly recommends using 512 MB of cache memory.

To upgrade cache module memory, its controller must be shut down. Use the following steps to upgrade or add DIMMs.



CAUTION: ESD can easily damage a cache module or a DIMM. Wear a snug-fitting, grounded ESD wrist strap.

1. From the host console, dismount the logical units in the subsystem.
2. If using a Windows NT platform, shut down the server.
3. If the controller is operating, connect a PC or terminal to the controller maintenance port.

If the controller is not operating, proceed to step 5.

4. Shut down the controllers.
 - In single-controller configurations, shut down “this controller” with the following command:

```
SHUTDOWN THIS_CONTROLLER
```

- In dual-redundant controller configurations, shut down the “other controller” first, then shut down “this controller” with the following commands:

```
SHUTDOWN OTHER_CONTROLLER
```

```
SHUTDOWN THIS_CONTROLLER
```

When the controllers shut down, the reset buttons and the first three LEDs are lit continuously (see Figure 5-2). Receiving this indication can take several minutes, depending on the amount of data that needs to be flushed from the cache modules.



CAUTION: For BA370 enclosures only:

- The ECB must be disabled—the status light is not lit and is not blinking—before disconnecting the ECB cable from the cache module.
 - Failure to disable the ECB might result in cache module damage.
-

5. For BA370 enclosures only:
 - a. Disable the ECB by pressing the battery disable switch until the status light stops blinking—approximately 5 seconds.
 - b. Disconnect the ECB cable from the cache module.
6. Disengage the two retaining levers on the cache module, remove it from the enclosure, and place it onto a grounded antistatic mat.

7. If adding DIMMs (see Figure 5-6):
 - a. Press the DIMM retaining clips ③ down for the vacant DIMM slot ②.
 - b. Insert the new DIMM ① straight into the slot, ensuring that the notches in the DIMM align with the tabs in the slot.
 - c. Close the retaining clips to lock the DIMM into place.
 - d. Repeat step a through step c for all DIMMs being added.

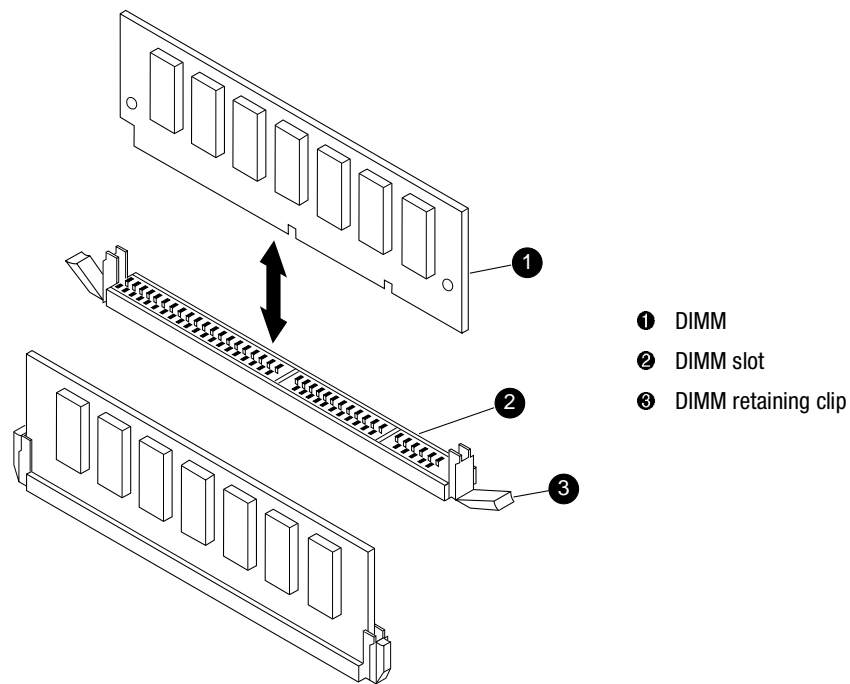

CXO6577B

Figure 5-6. DIMM components

8. If replacing DIMMs (see Figure 5-6):
 - a. Press down on the DIMM retaining clip ③ at both ends of the DIMM ① being removed.
 - b. Gently remove the DIMM from the DIMM slot ②.

- c. Insert the new DIMM  straight into the slot, ensuring that the notches in the DIMM align with the tabs in the slot.
 - d. Repeat step a through step c for each DIMM.
9. In a dual-redundant controller configuration, repeat step 5 through step 8, as appropriate, for the other cache module.

IMPORTANT: In a dual-redundant controller configuration, both cache modules must contain the same memory configuration. DO NOT proceed unless both cache modules contain identical amounts of cache memory.



CAUTION: Carefully align the cache module in the appropriate guide rails. Misalignment might damage the backplane.

10. Insert the cache module into its bay and engage the retaining levers.
11. For BA370 enclosures only, connect the ECB cable to the cache module.
12. In a dual-redundant controller configuration, repeat step 10 and step 11, as appropriate, for the other cache module.
13. Mount the logical units on the host.
14. If using a Windows NT platform, restart the server.
15. Set the subsystem date and time using the following command in its entirety:

```
SET THIS_CONTROLLER TIME=dd-mmm-yyyy:hh:mm:ss
```
16. Disconnect the PC or terminal from the controller maintenance port.

Chapter 6

Troubleshooting Resources

This chapter provides guidelines for troubleshooting the controller, cache module, and ECB. It also describes the utilities and exercisers available to aid in troubleshooting these components. See Chapter 7 for a list of event codes. See enclosure documentation for information on troubleshooting its hardware, such as the power supplies, cooling fans, and EMU.

Running the Controller Diagnostic Test

During startup, the controller automatically tests its device ports, host port, cache module, and value-added functions. If experiencing intermittent problems with one of these components, run the controller diagnostic test in a continuous loop, rather than restarting the controller over and over again.

Use the following steps to run the controller diagnostic test:

1. Connect a terminal to the controller maintenance port.
2. Start the self-test with one of the following commands:

```
SELFTEST THIS CONTROLLER  
SELFTEST OTHER_CONTROLLER
```

NOTE: The self-test runs until it detects an error or until the controller reset button is pressed.

If the self-test detects an error, it saves information about the error and produces an OCP LED code for a “daemon hard error.” Restart the controller to write the error information to the host error log, then check the log for a “built-in self-test failure”

event report. This report will contain an instance code, located at offset 32 through 35, that can be used to determine the cause of the error. See “Translating Event Codes” on page 6-29 for help on translating instance codes.

ECB Charging Diagnostics

Whenever restarting the controller, its diagnostic routines automatically check the charge of each ECB battery. If the battery is fully charged, the controller reports the battery as good and rechecks it every 24 hours. If the battery is charging, the controller rechecks it every 4 minutes. A battery is reported as being either above or below 50 percent in capacity. A battery below 50 percent in capacity is referred to as being low.

The 4-minute polling continues for the maximum time it takes to recharge the battery—up to 10 hours for a BA370 enclosure or 3.5 hours for a Model 2200 enclosure. If the battery does not charge sufficiently after the allotted time, the controller declares it as “failed.”

Battery Hysteresis

When charging an ECB battery, write-back caching is allowed as long as a previous down time did not drain more than 50 percent of ECB battery capacity. When an ECB battery is operating below 50 percent capacity, it is considered to be low and write-back caching is disabled.



CAUTION: *Compaq* recommends replacing an ECB every 2 years to prevent battery failure.

NOTE: If an uninterruptable power supply (UPS) is set to `DATACENTER_WIDE`, the controller does not check the battery. See the *Compaq StorageWorks HSG80 Array Controller ACS Version 8.5 Configuration Guide* and *Compaq StorageWorks HSG80 Array Controller ACS Version 8.5 CLI Reference Guide* for information about the UPS switches.

Typical Installation Troubleshooting Checklist

The following checklist provides a general procedure for diagnosing the controller and its supporting modules. By following this checklist, many of the problems that occur in a typical installation will be identified. After identifying a problem, use Table 6-1 to confirm the diagnosis and fix the problem.

If an initial diagnosis points to several possible causes, use tools in the “Utilities and Exercisers” section described later in this chapter to further refine the diagnosis. If a problem cannot be diagnosed using the checklist and tools, call *Compaq* customer service for additional support.

To troubleshoot the controller and its supporting modules:

1. Check the power to the enclosure and its components.
 - Are power cords connected properly?
 - Is power within specifications?
2. Check the component cables.
 - Are bus cables to the controllers connected properly?
 - For BA370 enclosures, are ECB cables connected properly?
3. Check each program card to make sure it is fully seated.
4. Check the OCP and devices for LED codes.

See “Flashing OCP Pattern Display Reporting,” page 6-19, and “Solid OCP Pattern Display Reporting,” page 6-21, to interpret the LED codes.

5. Connect a local terminal to the controller and check its configuration with the following command:

```
SHOW THIS_CONTROLLER FULL
```

Make sure that the ACS version loaded is correct and that pertinent patches are installed. Also, check the status of the cache module and its ECB.

In a dual redundant configuration, check the “other controller” with the following command:

```
SHOW OTHER_CONTROLLER FULL
```

6. Using FMU, check for “last failure” or “memory-system failure” entries.

Show these codes and translate the “last failure” codes they contain. See the section on “Displaying Failure Entries” on page 6-28 and “Translating Event Codes” on page 6-29.

If the controller failed to the extent that it cannot support a local terminal for FMU, check the host error log for the “instance” or “last failure” codes. See Chapter 7 to interpret the event codes.

7. Check device status with the following command:

```
SHOW DEVICES FULL
```

Look for errors such as “misconfigured device” or “No device at this PTL.” If a device reports misconfigured or missing, check its status with the following command:

```
SHOW device-name
```

8. Check storage set status with the following command:

```
SHOW STORAGESETS FULL
```

Make sure that all storage sets are normal (or normalizing if it is a RAID set or mirror set). Check again for misconfigured or missing devices using step 7.

9. Check unit status with the following command:

```
SHOW UNITS FULL
```

Make sure that all units are available or online. If the controller reports a unit as unavailable or offline, recheck the storage set it belongs to with the following command:

```
SHOW storage set-name
```

If the controller reports that a unit has lost data or is unwriteable, recheck the status of the devices that make up the storage set. If the devices are OK, recheck the status of the cache module. If the unit reports a media format error, recheck the status of the storage set and its devices.

Troubleshooting Table

After diagnosing a problem, use Table 6-1 to resolve it.

Table 6-1 Troubleshooting Table (Sheet 1 of 7)			
Symptom	Possible Cause	Investigation	Remedy
Reset button not lit.	No power to subsystem.	Check power to subsystem and power supplies on controller enclosure.	Replace cord or (BA370 enclosure only) AC input box.
		BA370 enclosure only: Make sure that all cooling fans are installed. If one or more fans are missing or all are inoperative for more than 8 minutes, the EMU shuts down the subsystem.	Turn off power switch on AC input box. Replace cooling fan. Restore power to subsystem.
		BA370 enclosure only: Determine if the standby power switch on the PVA was pressed for more than 5 seconds.	Press the alarm control switch on the EMU.
	Failed controller.	If the foregoing check fails to produce a remedy, check OCP LED codes.	Replace controller.
Reset button lit steadily; other LEDs also lit.	Various.	See OCP LED Codes.	Follow repair action using Table 6-4.
Reset button blinking; other LEDs also lit.	Device in error or FAIL set on corresponding device port with other LEDs lit.	SHOW <i>device</i> FULL.	Follow repair action using Table 6-5.

Table 6-1 Troubleshooting Table (Sheet 2 of 7)

Symptom	Possible Cause	Investigation	Remedy
Cannot set failover to create dual-redundant configuration.	Incorrect command syntax.	See the <i>Compaq StorageWorks HSG80 Array Controller ACS Version 8.5 CLI Reference Guide</i> for the SET FAILOVER command.	Use the correct command syntax.
	Different software versions on controllers.	Check software versions on both controllers.	Update one or both controllers so that both controllers are using the same software version.
	Incompatible hardware.	Check hardware versions.	Upgrade controllers so that they are using compatible hardware.
	Controller previously set for failover.	Make sure that neither controller is configured for failover.	Use the SET NOFAILOVER command on both controllers, then reset "this controller" for failover.
	Failed controller.	If the foregoing checks fail to produce a remedy, check for OCP LED codes.	Follow repair action using Table 6-4 or Table 6-5.
	Node ID is all zeros.	SHOW_THIS to see if node ID is all zeros.	Set node ID using the node ID (bar code) that is located on the frame in which the controller sits. See SET THIS CONTROLLER NODE_ID in <i>Compaq StorageWorks HSG80 Array Controller ACS Version 8.5 CLI Reference Guide</i> . Also, be sure to copy in the right direction. If cabled to the new controller, use SET FAILOVER COPY=OTHER. If cabled to old controller, use SET FAILOVER COPY=THIS.

Table 6-1 Troubleshooting Table (Sheet 3 of 7)

Symptom	Possible Cause	Investigation	Remedy
Nonmirrored cache; controller reports failed DIMM in cache module A or B.	Improperly installed DIMM.	Remove cache module and make sure that the DIMM is fully seated in its slot.	Reseat DIMM.
	Failed DIMM.	If the foregoing check fails to produce a remedy, check for OCP LED codes.	Replace DIMM.
Mirrored cache; "this controller" reports DIMM 1 or 2 failed in cache module A or B.	Improperly installed DIMM in "this controller" cache module.	Remove cache module and make sure that DIMMs are installed properly.	Reseat DIMM.
	Failed DIMM in "this controller" cache module.	If the foregoing check fails to produce a remedy, check for OCP LED codes.	Replace DIMM in "this controller" cache module.
Mirrored cache; "this controller" reports DIMM 3 or 4 failed in cache module A or B.	Improperly installed DIMM in "other controller" cache module.	Remove cache module and make sure that the DIMMs are installed properly.	Reseat DIMM.
	Failed DIMM in "other controller" cache module.	If the foregoing check fails to produce a remedy, check for OCP LED codes.	Replace DIMM in "other controller" cache module.
Mirrored cache; controller reports battery not present.	Memory module was installed before it was connected to an ECB.	BA370 enclosure: ECB cable not connected to cache module.	BA370 enclosure: Connect ECB cable to cache module, then restart both controllers by pushing their reset buttons simultaneously.
		M2 enclosure: ECB not installed or seated properly to backplane	M2 enclosure: install or reseat ECB.
Mirrored cache; controller reports cache or mirrored cache has failed.	Primary data and its mirrored copy data are not identical.	SHOW THIS_CONTROLLER indicates that the cache or mirrored cache has failed. Spontaneous FMU message displays: "Primary cache declared failed - data inconsistent with mirror," or "Mirrored cache declared failed - data inconsistent with primary."	Enter the SHUTDOWN command on controllers that report the problem. (This command flushes the contents of cache to synchronize its primary and mirrored data.) Restart the controllers that were shut down.

Table 6-1 Troubleshooting Table (Sheet 4 of 7)

Symptom	Possible Cause	Investigation	Remedy
Invalid cache.	Mirrored-cache mode discrepancy. This may occur after installing a new controller. Its existing cache module is set for mirrored caching, but the new controller is set for unmirrored caching. (It may also occur if the new controller is set for mirrored caching but its existing cache module is not.)	SHOW THIS CONTROLLER indicates "invalid cache." Spontaneous FMU message displays: "Cache modules inconsistent with mirror mode."	Connect a terminal to the maintenance port on the controller reporting the error and clear the error with the following command—all on one line: CLEAR_ERRORS THIS_CONTROLLER NODESTROY INVALID_CACHE.
	Cache module may erroneously contain unflushed write-back data. This may occur after installing a new controller. Its existing cache module may indicate that it contains unflushed write-back data, but the new controller expects to find no data in the existing cache module. (This error may also occur if installing a new cache module for a controller that expects write-back data in the cache.)	SHOW THIS CONTROLLER indicates "invalid cache." No spontaneous FMU message.	Connect a terminal to the maintenance port on the controller reporting the error, and clear the error with the following command—all on one line: CLEAR_ERRORS THIS_CONTROLLER DESTROY INVALID_CACHE. <i>See Compaq StorageWorks HSG80 Array Controller ACS Version 8.5 CLI Reference Guide for more information.</i>

Table 6–1 Troubleshooting Table (Sheet 5 of 7)

Symptom	Possible Cause	Investigation	Remedy
Cannot add device.	Illegal device.	See product-specific release notes that accompanied the software release for the most recent list of supported devices.	Replace device.
	Device not properly installed in enclosure.	Check that SBB is fully seated.	Firmly press SBB into slot.
	Failed device.	Check for presence of device LEDs.	Follow repair action in the documentation provided with the enclosure or device.
	Failed power supplies.	Check for presence of power supply LEDs.	Follow repair action in the documentation provided with the enclosure or power supply.
	Failed bus to device.	If the foregoing checks fail to produce a remedy, check for OCP LED codes.	Replace enclosure.
Cannot configure storagesets.	Incorrect command syntax.	See <i>Compaq StorageWorks HSG80 Array Controller ACS Version 8.5 CLI Reference Guide</i> for the <code>ADD storageset</code> command.	Reconfigure storageset with correct command syntax.
	Exceeded maximum number of storagesets.	Use the SHOW command to count the number of storagesets configured on the controller.	Delete unused storagesets.
	Failed battery on ECB. (An ECB or UPS is required for RAIDsets and mirrorsets.)	Use the SHOW command to check the ECB battery status.	Replace the ECB if required.

Table 6-1 Troubleshooting Table (Sheet 6 of 7)

Symptom	Possible Cause	Investigation	Remedy
Cannot assign unit number to storageset.	Incorrect command syntax.	See the <i>Compaq StorageWorks HSG80 Array Controller ACS Version 8.5 CLI Reference Guide</i> for correct syntax.	Reassign the unit number with the correct syntax.
	Incorrect SCSI target ID numbers set for controller that accesses desired unit. (First number of unit number must be one of the SCSI target ID numbers for the controller.)	Use the SHOW command to check the controller SCSI target ID numbers.	Reset the controller SCSI target ID numbers or assign a new unit number as desired.
Unit is available but not online.	This is normal. Units are "available" until the host accesses them, at which point their status is changed to "online."	None	None
Host cannot see device.	Broken cables or a missing, incorrect, or defective terminator.	Check for broken cables or a missing, incorrect, or defective terminator.	Replace broken cables or the missing, incorrect, or defective terminator.
Host cannot access unit.	Host files or device drivers not properly installed or configured.	Check for the required device special files.	Configure device special files as described in the getting started manual that accompanied the software release.
	Invalid Cache	See the description for the invalid cache symptom.	See the description for the invalid cache symptom.
	Unit(s) have lost data.	Issue the SHOW_UNIT command.	CLEAR_ERRORS <i>unit</i> lost data.

Table 6-1 Troubleshooting Table (Sheet 7 of 7)

Symptom	Possible Cause	Investigation	Remedy
Host log file or maintenance terminal indicates that a forced error occurred when the controller was reconstructing a RAIDset or mirrorset.	Unrecoverable read errors may have occurred when controller was reconstructing the storageset. Errors occur if another member fails while the controller is reconstructing the storageset.	Conduct a read scan of the storageset using the appropriate utility from the host operating system, such as the "dd" utility for a TRU64™ UNIX (formerly DIGITAL UNIX) host.	Rebuild the storageset, then restore its data from a backup source. While the controller is reconstructing the storageset, monitor the host error log activity or spontaneous event reports on the maintenance terminal for any unrecoverable errors. If unrecoverable errors persist, note the device on which they occurred, and replace the device before proceeding.
	Host requested data from a normalizing storageset that did not contain the data.	Use the SHOW <i>storageset-name</i> command to see if all of its members are "normal."	Wait for normalizing members to become normal, then resume I/O to them.

Caching Techniques

The cache module supports the following caching techniques to increase subsystem read and write performance:

- Read caching
- Read-ahead caching
- Write-through caching
- Write-back caching

Read Caching

When the controller receives a read request from the host, it reads the data from the disk drives, delivers it to the host, and stores the data in its cache module. Subsequent reads for the same data will take the data from cache rather than accessing the data from the disks. This process is called *read caching*.

Read caching can decrease the subsystem response time to many host read requests. If the host requests some or all of the cached data, the controller satisfies the request from its cache module rather than from the disk drives. By default, read caching is enabled for all storage units.

Read-Ahead Caching

Read-ahead caching begins when the controller has already processed a read request, and it receives a subsequent read request from the host. If the controller does not find the data in the cache memory, it reads the data from the disks and sends it to the cache memory.

During read-ahead caching, the controller anticipates subsequent read requests and begins to prefetch the next blocks of data from the disks as it sends the requested read data to the host. This is a parallel action. The controller notifies the host of the read completion, and subsequent sequential read requests are satisfied from the cache memory. By default, read-ahead caching is enabled for all disk units.

Write-Through Caching

When the controller receives a write request from the host, it places the data in its cache module, writes the data to the disk drives, then notifies the host when the write operation is complete. This process is called *write-through caching* because the data actually passes through—and is stored in—the cache memory on its way to the disk drives.

Write-Back Caching

Write-back caching improves the subsystem response time to write requests by allowing the controller to declare the write operation “complete” as soon as the data reaches its cache memory. The controller performs the slower operation of writing the data to the disk drives at a later time.

By default, write-back caching is enabled for all units. In either case, the controller will not provide write-back caching to a unit unless the cache memory is non-volatile, as described in the next section.

Fault-Tolerance for Write-Back Caching

The cache module supports nonvolatile memory and dynamic cache policies to protect the availability of its unwritten (write-back) data.

Nonvolatile Memory

Except for disaster-tolerant supported mirrorsets, the controller can provide write-back caching for storage units as long as the controller cache memory is nonvolatile. In other words, to enable write-back caching, connect a backup power source (an ECB) to the cache module to preserve the unwritten cache data in the event of a power failure. If cache memory were volatile—that is, if it did not have a backup power source—the unwritten cache data would be lost during a power failure.

By default, the controller expects to use an ECB as the backup power source for its cache module. However, if the subsystem is backed up using a UPS, two options are available:

- Use both the ECB and the UPS together (the `NODE_ONLY` setting—for BA370 enclosure only).
- Use only the UPS as the backup power source (the `DATACENTER_WIDE` setting).

Cache Policies Resulting from Cache Module Failures

If the controller detects a full or partial failure of its cache module or ECB, it automatically reacts to preserve the unwritten data in its cache module. Depending upon the severity of the failure, the controller chooses an interim caching technique—also called the cache policy—which it uses until the cache module or ECB is repaired or replaced.

Table 6-2 shows the cache policies resulting from a full or partial failure of cache module A in a dual-redundant controller configuration. The consequences shown in this table are the same for cache module B failures.

Table 6-3 shows the cache policies resulting from a full or partial failure of the ECB connected to cache module A in a dual-redundant controller configuration. The consequences shown are the opposite for an ECB failure connected to cache module B.

- If the ECB is at least 50% charged, the ECB is still good and is charging.
- If the ECB is less than 50% charged, the ECB is low, but still charging.

Table 6-2 Cache Policies—Cache Module Status

Cache Module Status		Cache Policy	
Cache A	Cache B	Unmirrored Cache	Mirrored Cache
Good.	Good.	Data loss: No. Cache policy: Both controllers support write-back caching. Failover: No.	Data loss: No. Cache policy: Both controllers support write-back caching. Failover: No.
Multibit cache memory failure.	Good.	Data loss: Forced error and loss of write-back data for which the multibit error occurred. Controller A detects and reports the lost blocks. Cache policy: Both controllers support write-back caching. Failover: No.	Data loss: No. Controller A recovers its lost write-back data from the mirrored copy on cache B. Cache policy: Both controllers support write-back caching. Failover: No.

Table 6-2 Cache Policies—Cache Module Status (Continued)

Cache Module Status		Cache Policy	
Cache A	Cache B	Unmirrored Cache	Mirrored Cache
DIMM or cache memory controller chip failure.	Good.	<p>Data integrity: Write-back data that was not written to media when failure occurred was not recovered.</p> <p>Cache policy: Controller A supports write-through caching only; controller B supports write-back caching.</p> <p>Failover: In transparent failover, all units failover to controller B. In multiple-bus failover with host-assist, only those units that use write-back caching, such as RAIDsets and mirrorsets, failover to controller B. All units with lost data become inoperative until they are cleared using the CLEAR LOST_DATA command. Units that did not lose data operate normally on controller B.</p> <p>In single-controller configurations, RAIDsets, mirrorsets, and all units with lost data become inoperative. Although lost data errors can be cleared on some units, RAIDsets and mirrorsets remain inoperative until the nonvolatile memory on cache A is repaired or replaced.</p>	<p>Data integrity: Controller A recovers all of its write-back data from the mirrored copy on cache B.</p> <p>Cache policy: Controller A supports write-through caching only; controller B supports write-back caching.</p> <p>Failover: In transparent failover, all units failover to controller B and operate normally. In multiple-bus failover with host-assist, only those units that use write-back caching, such as RAIDsets and mirrorsets, failover to controller B.</p>
Cache Board Failure.	Good.	Same as for DIMM failure.	<p>Data integrity: Controller A recovers all of its write-back data from the mirrored copy on cache B.</p> <p>Cache policy: Both controllers support write-through caching only. Controller B cannot execute mirrored writes because cache module A cannot mirror controller B unwritten data.</p> <p>Failover: No.</p>

Table 6-3 Resulting Cache Policies—ECB Status

Cache Module Status		Cache Policy	
Cache A	Cache B	Unmirrored Cache	Mirrored Cache
At least 50% charged.	At least 50% charged.	Data loss: No. Cache policy: Both controllers continue to support write-back caching. Failover: No.	Data loss: No. Cache policy: Both controllers continue to support write-back caching. Failover: No.
Less than 50% charged.	At least 50% charged.	Data loss: No. Cache policy: Controller A supports write-through caching only; controller B supports write-back caching. Failover: In transparent failover, all units failover to controller B. In multiple-bus failover with host-assist, only those units that use write-back caching, such as RAIDsets and mirrorsets, failover to controller B. In single-controller configurations, the controller only provides write-through caching to its units.	Data loss: No. Cache policy: Both controllers continue to support write-back caching. Failover: No.
Failed.	At least 50% charged.	Data loss: No. Cache policy: Controller A supports write-through caching only; controller B supports write-back caching. Failover: In transparent failover, all units failover to controller B and operate normally. In multiple-bus failover with host-assist, only those units that use write-back caching, such as RAIDsets and mirrorsets, failover to controller B. In single-controller configurations, the controller only provides write-through caching to its units.	Data loss: No. Cache policy: Both controllers continue to support write-back caching. Failover: No.

Table 6-3 Resulting Cache Policies—ECB Status (Continued)

Cache Module Status		Cache Policy	
Cache A	Cache B	Unmirrored Cache	Mirrored Cache
Less than 50% charged.	Less than 50% charged.	Data loss: No. Cache policy: Both controllers support write-through caching only. Failover: No.	Data loss: No. Cache policy: Both controllers support write-through caching only. Failover: No.
Failed.	Less than 50% charged.	Data loss: No. Cache policy: Both controllers support write-through caching only. Failover: In transparent failover, all units failover to controller B and operate normally. In multiple-bus failover with host-assist, only those units that use write-back caching, such as RAIDsets and mirrorsets, failover to controller B. In single-controller configurations, the controller only provides write-through caching to its units.	Data loss: No. Cache policy: Both controllers support write-through caching only. Failover: No.
Failed.	Failed.	Data loss: No. Cache policy: Both controllers support write-through caching only. Failover: No. RAIDsets and mirrorsets become inoperative. Other units that use write-back caching operate with write-through caching only.	Data loss: No. Cache policy: Both controllers support write-through caching only. Failover: No. RAIDsets and mirrorsets become inoperative. Other units that use write-back caching operate with write-through caching only.

Enabling Mirrored Write-Back Cache

Before configuring dual-redundant controllers and enabling mirroring, make sure the following conditions are met:

- Both cache modules are configured with the same size cache, 64 MB, 128 MB, 256 MB, or 512 MB.
- Diagnostics indicate that both caches are good.

- Both cache modules either:
 - Have an ECB connected and the UPS switch is set to one of the following:
 - ▲ NOUPS (no UPS is connected)
 - ▲ BA370 enclosure only: NODE_ONLY (a UPS is connected)
 - Do not have an ECB connected and the UPS switch is set to DATACENTER_WIDE
- No unit errors are outstanding (for example, lost data or data that cannot be written to devices).
- Both controllers are started and configured in failover mode.

For important considerations when adding or replacing DIMMs in a mirrored cache configuration, see Chapter 2.

Significant Event Reporting

Controller fault-management software reports information about significant events that occur. These events are reported via the:

- Maintenance terminal
- Host error log
- OCP

Some events cause controller operation to terminate; others allow the controller to remain operable. Each of these two instances is detailed in the following sections.

Events That Cause Controller Operation to Terminate

Events that cause the controller to terminate operations are reported three possible ways:

- a flashing OCP pattern display
- a solid OCP pattern display
- last failure reporting

Use Table 6-4 to interpret *FLASHING* OCP patterns and Table 6-5 to interpret *solid (ON)* OCP patterns. In the ERROR column of the solid OCP patterns, there are two separate descriptions. The first denotes the actual error message that appears on the terminal, and the second provides a more detailed explanation of the designated error.

Use the following legend for both tables:

- = reset button FLASHING (in Table 6-4) or ON (in TABLE 6-5)
- = reset button OFF
- = LED FLASHING (in Table 6-4) or ON (in TABLE 6-5)
- = LED OFF

NOTE: If the reset button is FLASHING and an LED is ON, either the devices on that LED bus do not match the controller configuration, or an error occurred in one of the devices on that bus.

Also, a single LED that is turned ON indicates a failure of the drive on that port.

Flashing OCP Pattern Display Reporting

Certain events can cause a *FLASHING* display of the OCP LEDs. The event and its resulting patterns are described in Table 6-4.

NOTE: Reminder: a solid black pattern represents a FLASHING display. A white pattern indicates OFF.

All LEDs FLASH at the same time and at the same rate.

Table 6-4 FLASHING OCP Patterns

Pattern	OCP Code	Error	Repair Action
■○○○○●	1	Program card EDC error.	Replace program card.
■○○●○○	4	Timer zero on the processor is bad.	Replace controller.
■○○●●●	5	Timer one on the processor is bad.	Replace controller.
■○○●●○	6	Processor Guarded Memory Unit (GMU) is bad.	Replace controller.
■○○●●●	B	Nonvolatile Journal Memory (JSRAM) structure is bad because of a memory error or an incorrect upgrade procedure.	Verify the correct upgrade (see the <i>HSG80 Array Controller ACS Version 8.X Release Notes</i>). If error continues, replace controller.
■○○●●●	D	One or more bits in the diagnostic registers did not match the expected reset value.	Press the reset button to restart the controller. If this does not correct the error, replace the controller.
■○○●●○	E	Memory error in the JSRAM.	Replace controller.

Table 6-4 FLASHING OCP Patterns (Continued)

Pattern	OCP Code	Error	Repair Action
■○○●●●●	F	Wrong image found on program card.	Replace program card or replace controller if needed.
■●●○○○○	10	Controller Module memory is bad.	Replace controller.
■●●○○●○	12	Controller Module memory addressing is malfunctioning.	Replace controller.
■●●○○●●	13	Controller Module memory parity is not working.	Replace controller.
■●●●●○○	14	Controller Module memory controller timer has failed.	Replace controller.
■●●●○○●	15	The Controller Module memory controller interrupt handler has failed.	Replace controller.
■●●●●●○	1E	During the diagnostic memory test, the Controller Module memory controller caused an unexpected Non-Maskable Interrupt (NMI).	Replace controller.
■●○○●○○	24	The card code image changed when the contents were copied to memory.	Replace controller.
■●●○○○○	30	The JSRAM battery is bad.	Replace controller.
■●●○○●○	32	First-half diagnostics of the Time of Year Clock failed.	Replace controller.
■●●○○●●	33	Second-half diagnostics of the Time of Year Clock failed.	Replace controller.
■●●●●○○	35	The processor bus-to-device bus bridge chip is bad.	Replace controller.
■●●●●●●	3B	There is an unnecessary interrupt pending.	Replace controller.
■●●●●○○	3C	There was an unexpected fault during initialization.	Replace controller.
■●●●●●○	3D	There was an unexpected maskable interrupt during initialization.	Replace controller.

Table 6-4 FLASHING OCP Patterns (Continued)

Pattern	OCP Code	Error	Repair Action
■●●●●●○	3E	There was an unexpected NMI during initialization.	Replace controller.
■●●●●●●	3F	An invalid process ran during initialization.	Replace controller.

Solid OCP Pattern Display Reporting

Certain events cause a *solid* display of the OCP LEDs. The event and its resulting patterns are described in Table 6-5.

Information related to the solid OCP patterns is automatically displayed on the maintenance terminal (unless disabled via the FMU) using %FLL formatting, as detailed in the following examples:

```
%FLL--HSG> --13-JAN-1999 04:39:45 (time not set)-- OCP Code: 38
Controller operation terminated.
```

```
%FLL--HSG> --13-JAN-1999 04:32:26 (time not set)-- OCP Code: 26
Memory module is missing.
```

Table 6-5 Solid OCP Patterns (Sheet 1 of 5)

Pattern	OCP Code	Error	Repair Action
■○○○○○○○	0	No program card detected or kill asserted by other controller. Controller unable to read program card.	Make sure that the program card is properly seated while resetting the controller. If the error persists, try the card with another controller; or replace the card. Otherwise, replace the controller that reported the error.
□○○○○○○○	0	Catastrophic controller or power failure.	Check power. If good, reset controller. If problem persists, reseal controller module and reset controller. If problem is still evident, replace controller module.

Table 6-5 Solid OCP Patterns (Sheet 2 of 5)

Pattern	OCP Code	Error	Repair Action
■●○○●○○	25	Recursive Bugcheck detected. The same bugcheck has occurred three times within 10 minutes, and controller operation has terminated.	Reset the controller. If this fault pattern is displayed repeatedly, follow the repair action(s) associated with the Last Failure code that is repeatedly terminating controller execution.
■●○○●●○○	26	Indicated memory module is missing. Controller is unable to detect a particular memory module.	Insert memory module (cache board).
■●○○●●●●	27	Memory module has insufficient usable memory.	Replace indicated DIMM(s). (This indication is only provided when Fault LED logging is enabled).
■●●●○○○○	28	An unexpected Machine Fault/NMI occurred during Last Failure processing. A machine fault was detected while a Non-Maskable Interrupt was processing.	Reset the controller.
■●●●○○●●	29	EMU protocol version incompatible. The microcode in the EMU and the software in the controller are not compatible.	Upgrade either the EMU microcode or the software (refer to the Release Notes that accompanied the controller software).
■●●●●○○○	2A	All enclosure I/O modules are not of the same type. Enclosure I/O modules are a combination of single-sided and differential.	Make sure that the I/O modules in an extended subsystem are either all single-ended or all differential, not both.
■●○○●○○●	2B	Jumpers not terminators found on backplane. One or more SCSI bus terminators are either missing from the backplane or broken.	Make sure that enclosure SCSI bus terminators are installed and that there are no jumpers. Replace the failed terminator if the problem continues.
■●○○●●○○	2C	Enclosure I/O termination power out of range. Faulty or missing I/O module causes enclosure I/O termination power to be out of range.	Make sure that all of the enclosure device SCSI buses have an I/O module. If problem persists, replace the failed I/O module.

Table 6-5 Solid OCP Patterns (Sheet 3 of 5)

Pattern	OCP Code	Error	Repair Action
■●○●●○●●	2D	All master enclosure SCSI buses are not set to ID 0.	Set PVA ID to 0 for the enclosure with the controllers. If problem persists, try the following repair actions: <ol style="list-style-type: none"> 1. Replace the PVA module. 2. Replace the EMU. 3. Remove all devices. 4. Replace the enclosure.
■●○●●●○	2E	Multiple enclosures have the same SCSI ID. More than one enclosure have the same SCSI ID.	Reconfigure PVA ID to uniquely-identify each enclosure in the subsystem. The enclosure with the controllers must be set to PVA ID 0; additional enclosures must use PVA IDs 2 and 3. If error continues after PVA settings are unique, replace each PVA module one at a time. Check enclosure if problem remains.
■●○●●●●	2F	Memory module has illegal DIMM configuration.	Verify that DIMMs are installed correctly.
■●●○●○●○	30	An unexpected bugcheck occurred before subsystem initialization completed. An unexpected Last Failure occurred during initialization.	Reinsert controller. If that does not correct the problem, reset the controller. If the error persists, try resetting the controller again, and replace it if no change occurs.
■●●○●○●●	31	ILF\$INIT unable to allocate memory. Attempt to allocate memory by ILF\$INIT failed.	Replace controller.
■●●○●○●○	32	Code load program card write failure. Attempt to update program card failed.	Replace program card.
■●●○●○●●	33	NVPM structure revision too low. NVPM structure revision number is less than the one that can be handled by the software version attempting to be executed.	Verify that the program card contains the latest software version. If the error persists, replace controller.

Table 6-5 Solid OCP Patterns (Sheet 4 of 5)

Pattern	OCP Code	Error	Repair Action
■●●●○●●●	35	An unexpected bugcheck occurred during Last Failure processing. Last Failure Processing interrupted by another Last Failure event.	Reset controller.
■●●●○●●○	36	Hardware-induced controller reset expected. Automatic hardware reset failed.	Replace controller.
■●●●○●●●	37	Software-induced controller reset expected. Software-induced reset failed.	Replace controller.
■●●●○●●○	38	Controller operation terminated. Last Failure event required termination of controller operation (e.g. SHUT DOWN VIA CLI).	Reset controller.
■●●●○●●●	39	NVPM configuration inconsistent. Device configuration within the NVPM is inconsistent.	Replace controller.
■●●●○●●○	3A	An unexpected NMI occurred during Last Failure processing. Last Failure processing interrupted by a Non-Maskable Interrupt (NMI).	Replace controller.
■●●●○●●●	3B	NVPM read loop hang. Attempt to read data from NVPM failed.	Replace controller.
■●●●○●●○	3C	NVPM write loop hang. Attempt to write data to NVPM failed.	Replace controller.
■●●●○●●●	3D	NVPM structure revision greater than image. NVPM structure revision number is greater than the one that can be handled by the software version attempting to be executed.	Replace program card with one that contains the latest software version.

Table 6-5 Solid OCP Patterns (Sheet 5 of 5)

Pattern	OCP Code	Error	Repair Action
■●●●●●●●	3F	<p>DAEMON diagnostic failed hard in non-fault tolerant mode.</p> <p>DAEMON diagnostic detected critical hardware component failure; controller can no longer operate.</p>	Verify that cache module is present. If the error persists, replace controller.

Last Failure Reporting

Last failures are automatically displayed on the maintenance terminal (unless disabled via the FMU) using %LFL formatting. The example below details an occurrence of a Last Failure report:

```
%LFL--HSG> --13-JAN-1999 04:39:45 (time not set)-- Last Failure
Code: 20090010
Power On Time: 0.Years, 14.Days, 19.Hours, 58.Minutes, 42.Seconds
Controller Model: HSG80
Serial Number: AA12345678 Hardware Version: 0000(00)
Software Version: V085F(55)
Informational Report
Instance Code: 0102030A
Last Failure Code: 20090010 (No Last Failure Parameters)
```

Additional information is available in Last Failure Entry: 1.

In addition, Last Failures are reported to the host error log using Template 01, following a restart of the controller. See Table 7-2 for a more detailed explanation of this template.

Events That Allow Controller Operation to Continue

Events that do not cause controller operation to terminate are displayed in one of two ways:

- Spontaneous event log
- CLI event reporting

Spontaneous Event Log

Spontaneous event logs are automatically displayed on the maintenance terminal (unless disabled via the FMU) using %EVL formatting, as illustrated in the following examples:

```
%EVL--HSG> --13-JAN-1999 04:32:47 (time not set)-- Instance Code: 0102030A
(not yet reported to host)
Template: 1.(01)
Power On Time: 0.Years, 14.Days, 19.Hours, 58.Minutes, 43.Seconds
Controller Model: HSG80
Serial Number: AA12345678 Hardware Version: 0000(00)
Software Version: V085F(55)
Informational Report
Instance Code: 0102030A
Last Failure Code: 011C0011
Last Failure Parameter[0.] 0000003F
```

```
%EVL--HSG> --13-JAN-1999 04:32:47 (time not set)-- Instance Code: 82042002
(not yet reported to host)
Template: 19.(13)
Power On Time: 0.Years, 14.Days, 19.Hours, 58.Minutes, 43.Seconds
Controller Model: HSG80
Serial Number: AA12345678 Hardware Version: 0000(00)
Software Version: V085F(55)
Header type: 00 Header flags: 00
Test entity number: 0F Test number Demand/Failure: F8 Command: 01
Error Code: 0008 Return Code: 0005 Address of Error: A0000000
Expected Error Data: 44FCFCFC Actual Error Data: FFFF01BB
Extra Status(1): 00000000 Extra Status(2): 00000000 Extra Status(3):
00000000
Instance Code: 82042002
HSG>
```

Spontaneous event logs are reported to the host error log using SCSI Sense Data Templates 01, 04, 05, 11, 12, 13, 14, 41, 51, and 90. See Chapter 7 for a more detailed explanation of templates.

CLI Event Reporting

CLI event reports are automatically displayed on the maintenance terminal (unless disabled via the FMU) using %CER formatting, as shown in the following example:

```
%CER--HSG> --13-JAN-1999 04:32:20 (time not set)-- Previous controller-  
operation terminated with display of solid fault code, OCP Code: 3F  
HSG>
```

Utilities and Exercisers

Controller software includes utilities and exercisers to assist in troubleshooting and maintaining the controller and the other modules that support its operation. These utilities and exercisers include:

- Fault management utility (FMU)
- Video terminal display (VTDPY) utility
- Disk inline exerciser (DILX)
- Format and device code load utility (HSUTIL)
- Configuration (CONFIG) utility
- Code load and code patch (CLCP) utility
- CLONE utility
- Field replacement utility (FRUTIL)
- Change volume serial number (CHVSN) utility
- Device statistics (DSTAT) utility—not supported

FMU

The FMU provides a limited interface to the controller fault management software. Use FMU to:

- Display the last failure and memory-system-failure entries that the fault management software stores in the controller non-volatile memory.
- Translate many of the code values contained in event messages. For example, entries might contain code values that indicate the cause of the event, the software component that reported the event, the repair action, and so on.

- Display the instance codes that identify and accompany significant events which do not cause the controller to terminate operation.
- Display the last-failure codes that identify and accompany failure events which cause the controller to stop operating. Last-failure codes are sent to the host only after the affected controller is restarted successfully.
- Control the display characteristics of significant events and failures that the fault management system displays on the maintenance terminal. See “Controlling the Display of Significant Events and Failures,” page 6-31, for specific details on this feature.

Displaying Failure Entries

The controller stores the 16 most recent last-failure reports as entries in its non-volatile memory. The occurrence of any failure event terminates operation of the controller on which it occurred.

NOTE: Memory system failures are reported through the last failure mechanism but can be displayed separately.

Use the following steps to display the last-failure entries:

1. Connect a PC or a local terminal to the controller maintenance port.
2. Start FMU with the following command:

```
RUN FMU
```

3. Show one or more of the entries with the following command:

```
SHOW event_type entry# FULL
```

where:

- *event-type* is LAST_FAILURE or MEMORY_SYSTEM_FAILURE
 - *entry#* is ALL, MOST_RECENT, or 1 through 16
 - *FULL* displays additional information, such as the I960 stack and hardware component register sets (for example, the memory controller, FX, host port, and device ports, and so on).
4. Exit FMU with the following command:

```
EXIT
```

The following example shows a last-failure entry. The Informational Report—the lower half of the entry—contains the last failure code, reporting component, and so forth that can be translated with FMU to learn more about the event.

```

Last Failure Entry: 4. Flags: 006FF300
Template: 1.(01) Description: Last Failure Event
Power On Time: 0. Years, 14. Days, 19. Hours, 51. Minutes, 31. Seconds
Controller Model: HSG80
Serial Number: AA12345678 Hardware Version: 0000(00)
Software Version: V085F(55)
Informational Report
Instance Code: 0102030A Description:
An unrecoverable software inconsistency was detected or an intentional
restart or shutdown of controller operation was requested.
Reporting Component: 1.(01) Description:
Executive Services
Reporting component's event number: 2.(02)
Event Threshold: 10.(0A) Classification:
SOFT. An unexpected condition detected by a controller software component
(e.g., protocol violations, host buffer access errors, internal
inconsistencies, uninterpreted device errors, etc.) or an intentional
restart or shutdown of controller operation is indicated.
Last Failure Code: 20090010 (No Last Failure Parameters)
Last Failure Code: 20090010 Description:
This controller requested this controller to shutdown.
Reporting Component: 32.(20) Description:
Command Line Interpreter
Reporting component's event number: 9.(09)
Restart Type: 1.(01) Description: No restart

```

Translating Event Codes

Use the following steps to translate the event codes in the fault management reports for spontaneous events and failures.

1. Connect a PC or a local terminal to the controller maintenance port.
2. Start FMU with the following command:

```
RUN FMU
```

3. Show one or more of the entries with the following command:

```
DESCRIBE code_type code#
```

where:

- *code_type* is one of those listed in Table 6-6

- *code#* is the alpha-numeric value displayed in the entry
- code types marked with an asterisk (*) require multiple code numbers

Table 6-6 Event-Code Types

Event-Code Type	Event-Code Type
ASC_ASCQ_CODE*	REPAIR_ACTION_CODE
COMPONENT_CODE	RESTART_TYPE
CONTROLLER_UNIQUE_ASC_ASCQ_CODE*	SCSI_COMMAND_OPERATION_CODE*
DEVICE_TYPE_CODE	SENSE_DATA_QUALIFIERS*
EVENT_THRESHOLD_CODE	SENSE_KEY_CODE
INSTANCE_CODE	TEMPLATE_CODE
LAST_FAILURE_CODE	

The following examples show the FMU translation of a last-failure code and an instance code.

```

FMU>DESCRIBE LAST_FAILURE_CODE 206C0020
Last Failure Code: 206C0020
Description: Controller was forced to restart in order for new controller
code image to take effect.
Reporting Component: 32.(20)
Description: Command Line Interpreter
Reporting component's event number: 108.(6C)
Restart Type: 2.(02)
Description: Automatic hardware restart
    
```

```

FMU>DESCRIBE INSTANCE 026e0001
Instance Code: 026E0001
Description: The device specified in the Device Locator field has been
reduced from the Mirrorset associated with the logical unit. The nominal
number of members in the mirrorset has been decreased by one. The reduced
device is now available for use.
Reporting Component: 2.(02)
Description: Value Added Services
Reporting component's event number: 110.(6E)
Event Threshold: 1.(01) Classification:
IMMEDIATE. Failure or potential failure of a component critical to proper
controller operation is indicated; immediate attention is required.
    
```

Controlling the Display of Significant Events and Failures

Use the SET command to control how the fault management software displays significant events and failures.

Table 6-7 describes various SET commands that can be entered while running FMU. These commands remain in effect only as long as the current FMU session remains active, unless the PERMANENT qualifier is entered (the last entry in the table).

Table 6-7 FMU SET Commands

Command	Result
SET EVENT_LOGGING SET NOEVENT_LOGGING	<p>Enable and disable the spontaneous display of significant events to the local terminal; preceded by “%EVL.” By default, logging is enabled (SET EVENT_LOGGING).</p> <p>When logging is enabled, the controller spontaneously displays information about the events on the local terminal. Spontaneous event logging is suspended during the execution of CLI commands and operation of utilities on a local terminal. Because these events are spontaneous, logs are not stored by the controller.</p>
SET LAST_FAILURE LOGGING SET NOLAST_FAILURE LOGGING	<p>Enable and disable the spontaneous display of last failure events; preceded by “%LFL.” By default, logging is enabled (SET LAST_FAILURE LOGGING).</p> <p>The controller spontaneously displays information relevant to the sudden termination of controller operation.</p> <p>In cases of automatic hardware reset (for example, power failure or pressing the controller reset button), the fault LED log display is inhibited because automatic resets do not allow sufficient time to complete the log display.</p>
SET <i>log_type</i> REPAIR_ACTION SET <i>log_type</i> NOREPAIR_ACTION	<p>Enable and disable the inclusion of repair action information for event logging or last-failure logging. By default, repair actions are not displayed for these log types (SET <i>log_type</i> NOREPAIR_ACTION). If the display of repair actions is enabled, the controller displays any of the recommended repair actions associated with the event.</p>
SET <i>log_type</i> VERBOSE SET <i>log_type</i> NOVERBOSE	<p>Enable and disable the automatic translation of event codes that are contained in event logs or last-failure logs. By default, this descriptive text is not displayed (SET <i>log_type</i> NOVERBOSE). See “Translating Event Codes,” page 6-29, for instructions to translate these codes manually.</p>

Table 6-7 FMU SET Commands (Continued)

Command	Result
SET PROMPT SET NOPROMPT	Enable and disable the display of the CLI prompt string following the log identifier “%EVL,” or “%LFL,” or “%FLL.” This command is useful if the CLI prompt string is used to identify the controllers in a dual-redundant configuration (see the <i>Compaq StorageWorks HSG80 Array Controller ACS Version 8.5 CLI Reference Guide</i> for instructions to set the CLI command string for a controller). If enabled, the CLI prompt will be able to identify which controller sent the log to the local terminal. By default, the prompt is set (SET PROMPT).
SET TIMESTAMP SET NOTIMESTAMP	Enable and disable the display of the current date and time in the first line of an event or last-failure log. By default, the timestamp is set (SET TIMESTAMP)
SET FMU_REPAIR_ACTION SET FMU_NOREPAIR_ACTION	Enable and disable the inclusion of repair actions with SHOW LAST_FAILURE and SHOW MEMORY_SYSTEM_FAILURE commands. By default, the repair actions are not shown (SET FMU_NOREPAIR_ACTION). If repair actions are enabled, the command outputs display all of the recommended repair actions associated with the instance or last-failure codes used to describe an event.
SET FMU_VERBOSE SET FMU_NOVERBOSE	Enable and disable the inclusion of instance and last failure code descriptive text with SHOW LAST_FAILURE and SHOW MEMORY_SYSTEM_FAILURE commands. By default, this descriptive text is not displayed (SET FMU_NOVERBOSE). If the descriptive text is enabled, it identifies the fields and their numeric content that comprise an event or last-failure entry.
SET CLI_EVENT_REPORTING SET NOCLI_EVENT_REPORTING	Enable and disable the asynchronous errors reported at the CLI prompt (for example, “swap signals disabled” or “shelf (enclosure) has a bad power supply”). Preceded by “%CER.” By default, these errors are reported (SET CLI_EVENT_REPORTING). These errors are cleared with the CLEAR_ERRORS_CLI command.
SET FAULT_LED_LOGGING SET NOFAULT_LED_LOGGING	Enable and disable the solid fault LED event log display on the local terminal. Preceded by “%FLL.” By default, logging is enabled (SET FAULT_LED_LOGGING). When enabled, and a solid fault pattern is displayed in the OCP LEDs, the fault pattern and its meaning are displayed on the maintenance terminal. For many of the patterns, additional information is also displayed to aid in problem diagnosis. In cases of automatic hardware reset (for example, power failure or pressing the controller reset button), the fault LED log display is inhibited because automatic resets do not allow sufficient time to complete the log display.
SHOW PARAMETERS	Displays the current settings associated with the SET command.
SET <i>command</i> PERMANENT	Preserves the SET command across controller resets.

Using VTDPY to Check for Communication Problems

Use the VTDPY utility to obtain information about the following communications:

- Communication between the controller and its hosts.
- Communication between the controller and subsystem devices.
- State and I/O activity of logical units, devices, and device ports in the subsystem.
- Monitoring communication between local and remote controllers in a Data Replication Manager configuration.

Use the following steps to run VTDPY:

1. Connect a terminal to the controller maintenance port.

NOTE: This terminal must support ANSI control sequences.

2. Set the terminal to NOWRAP mode to prevent the top line of the display from scrolling off of the screen.
3. Start VTDPY with the following command:

```
RUN VTDPY
```

Use the key sequences and commands listed in Table 6-8 to control VTDPY.

Table 6-8 VTDPY Key Sequences and Commands

Command	Action
Ctrl/C	Enables command mode; after entering Ctrl/C, enter one of the following commands and press Enter/Return : CLEAR DISPLAY CACHE DISPLAY DEFAULT DISPLAY DEVICE DISPLAY HOST DISPLAY REMOTE (ACS V8.5P only) DISPLAY STATUS HELP INTERVAL <i>seconds</i> (to change update interval)
Ctrl/G	Updates screen
Ctrl/O	Pauses (and resumes) screen updates

Table 6-8 VTDPY Key Sequences and Commands (Continued)

Ctrl/R	Refreshes current screen display
Ctrl/Y	Exits VTDPY

Commands can be abbreviated to the minimum number of characters necessary to identify the command. Enter a question mark (?) after a partial command to see the values that can follow the supplied command.

For example, if DISP ? is entered, the utility will list CACHE, DEFAULT, and so forth. (Separate “DISP” and “?” with a space.)

Upon successfully executing a command—other than HELP—VTDPY exits command mode. Pressing Return without a command also causes VTDPY to exit command mode.

Checking Controller-to-Host Communications

Use the display host VTDPY command to see how or if the controller is communicating with the host (see Figure 6-1). The display for ACS V8.5P differs slightly.

```
VTDPY> DISPLAY DEFAULT

HSG80          S/N: ZG92712820  SW: SSDRS-0  HW: E-06
              0.0% Idle      0 KB/S          0 Rq/S          Up: 0 22:10.03

Pr Name  Stk/Max Typ  Sta CPU%      Target      Unit  ASWC  KB/S  Rd%  Wr%  Cm%  HT%
0  NULL  0/0          Rn  0.0          111111  D0001  x a    0    0   0   0   0
          0123456789012345  D0002  o^ a    0   66  33   0   0
          P1DDDD  hHDDDDDDDD  D0003  o^ a    0  100   0   0   0
          o2DDDD  hHDDDDDDDD  D0004  o^ a    0  100   0   0   0
          r3DDDD  hHDDDDDDDD  D0005  o^ a    0  100   0   0   0
          t4DDDD  hH  DDDDD  D  D0006  x a    0    0   0   0   0
          5 DDD  hHDDDDDDDD  D0081  x a    0    0   0   0   0
          6DDDD  hHDDDDDDDD  D0082  x a    0    0   0   0   0
                   D0083  x a    0    0   0   0   0
                   D0084  x a    0    0   0   0   0
                   D0088  x a    0    0   0   0   0
                   D0092  x a    0    0   0   0   0
```

Figure 6-1. Sample of transfer (Xfer) rate region of the default display

Table 6-9 lists the heading and contents for each column of the default display and status display.

Table 6-9 VTDPY Default Display Columns

Column	Contents
Pr	Process priority
Name	Priority name or NULL (idle)
Stk/Max	Stack size in 512 byte pages and maximum number of stack pages actually used
Typ	Process type:
	FNC = functional process
	DUP = resident device utility/exerciser in use
Sta	Status:
	BI = waiting for completion of a process currently running
	Io = waiting for input or output
	Rn = actively running
CPU%	Percentage of central processing unit resource consumption
Port	SCSI ports 1 through 6.
Target	SCSI targets 0 through 15. Single controllers occupy 7; dual-redundant controllers occupy 6 and 7.
	D = disk drive or CD-ROM drive
	F = foreign device
	H = this controller
	h = other controller in dual-redundant configurations
	P = passthrough device
	? = unknown device type
	= no device at this port/target location
Unit Type	Kind of unit (and its unit number):
	D = disk drive or CD-ROM drive
	I = invisible device
	P = passthrough device
	? = unknown device type

Table 6-9 VTDPY Default Display Columns (Continued)

Column	Contents
A	Availability of the unit:
	a = available to "other controller"
	d = disabled for servicing, offline
	e = mounted for exclusive access by a user
	f = media format error
	i = inoperative
	m = maintenance mode for diagnostic purposes
	o = online. Host can access this unit through "this controller".
	r = rundown with the SET NORUN command
	v = no volume mounted due to lack of media
	x = online. Host can access this unit through "other controller".
	z = currently not accessible to host due to a remote copy condition (ACS V8.5P only)
	= unknown availability
S	Spindle state of the device:
	^ = disk spinning at correct speed; tape loaded
	> = disk spinning up
	< = disk spinning down
	v = disk not spinning
	= unknown spindle state
W	Write-protection state of the device. For disk drives, a W in this column indicates that the device is hardware write-protected. This column is blank for other kinds of devices.
C	Caching state of the device:
	a = read, write-back, and read-ahead caching enabled
	b = read and write-back caching enabled
	c = read and read-ahead caching enabled
	p = read-ahead caching enabled
	r = read caching only
	= caching disabled

Table 6-9 VTDPY Default Display Columns (Continued)

Column	Contents
KB/S	Average amount of data transferred to and from the unit during the last update interval in 1000-byte increments.
Rd%	Percentage of data transferred between the host and the unit that were read from the unit.
Wr%	Percentage of data transferred between the host and the unit that were written to the unit.
CM%	Percentage of data transferred between the host and the unit that were compared. A compare operation can accompany a read or a write operation, so this column is not the sum of columns Rd% and Wr%.
HT%	Cache-hit percentage for data transferred between the host and the unit.

Checking Controller-to-Device Communications

Use the VTDPY display device to see how or if the controller is communicating with the devices in the subsystem (see Figure 6-2). This display contains three important regions:

- Device map region (upper left)
- Device status region (upper right)
- Device-port status region (lower left)

VTDPY>DISPLAY DEVICE

HSG80 S/N: ZG92712820 SW: SDRS-0 HW: E-06
 99.9% Idle 0 KB/S 0 Rq/S Up: 0 22:08.21

Target	P TL	ASWF	Rq/S	RdKB/S	WrKB/S	Que	Tg	BR	ER
111111	P1120	A^	0	0	0	0	0	0	0
0123456789012345	D1130	A^	0	0	0	0	0	0	0
P1 hH PDD	D1140	A^	0	0	0	0	0	0	0
o2 hH DDD	D2120	A^	0	0	0	0	0	0	0
r3 ???hH	D2130	A^	0	0	0	0	0	0	0
t4 hH DDD	D2140	a^	0	0	0	0	0	0	0
5 P hH	?3020	^ F	0	0	0	0	0	0	0
6D hH	?3030	^ F	0	0	0	0	0	0	0
	?3040	^ F	0	0	0	0	0	0	0
	?3050	^ F	0	0	0	0	0	0	0
	D4090	A^	0	0	0	0	0	0	0
	D4100	A^	0	0	0	0	0	0	0
	D4110	A^	0	0	0	0	0	0	0
	P5030	A^	0	0	0	0	0	0	0
	D6010	A^	0	0	0	0	0	0	0

Port	Rq/S	RdKB/S	WrKB/S	CR	BR	TR
1	0	0	0	0	0	0
2	0	0	0	0	0	0
3	0	0	0	0	0	0
4	0	0	0	0	0	0
5	0	0	0	0	0	0
6	0	0	0	0	0	0

Figure 6-2. Sample of regions on the device display

Checking Device Type and Location

The device map region of the device display (see Figure 6-2, upper left) shows all of the devices that the controller recognizes through its device ports. Table 6-10 lists the heading and contents for each column of the device map region.

Table 6-10 Device Map Columns

Column	Contents
Port	SCSI ports 1 through 6.
Target	SCSI targets 0 through 15. Single controllers occupy 7; dual-redundant controllers occupy 6 and 7.
	D = disk drive or CD-ROM drive
	F = foreign device
	H = this controller
	h = other controller in dual-redundant configurations
	P = passthrough device
	? = unknown device type
	= no device at this port/target location

Checking Device Status and I/O Activity

The device status region of the device display (see Figure 6-2, upper right) shows the name and I/O characteristics for all of the devices that the controller recognizes.

Table 6-11 lists the heading and contents for each column of the device status region.

Table 6-11 Device Status Columns

Column	Contents
PTL	Kind of device and its port-target-lun (PTL) location:
	D = disk drive
	P = passthrough device
	? = unknown device type
	= no device at this port/target location
A	Availability of the device:
	A = available to "this controller"
	a = available to "other controller"
	U = unavailable, but configured on "this controller"
	u = unavailable, but configured on "other controller"
	= unknown availability state

Table 6-11 Device Status Columns (Continued)

Column	Contents
S	Spindle state of the device: ^ = disk spinning at correct speed; tape loaded > = disk spinning up < = disk spinning down v = disk not spinning = unknown spindle state
W	Write-protection state of the device. For disk drives, a W in this column indicates that the device is hardware write-protected. This column is blank for other kinds of devices.
F	Fault state of the device. An F in this column indicates an unrecoverable device fault. If this field is set, the device fault LED should also be lit.
Rq/S	Average request rate for the device during the last update interval. Requests can be up to 32K and generated by host or cache activity.
RdKB/S	Average data transfer rate from the device (reads) during the last update interval.
WrKB/S	Average data transfer rate to the device (writes) during the last update interval.
Que	Maximum number of I/O requests waiting to be transferred to the device during the last update interval.
Tg	Maximum number of requests queued to the device during the last update interval. If the device does not support tagged queuing, the maximum value is 1.
BR	Number of SCSI bus resets that occurred since VTDPY was started.
ER	Number of SCSI errors received. If the device is swapped or deleted, then the value clears and resets to 0.

Checking Device-Port Status and I/O Activity

The device-port status region of the device display (see Figure 6-2, lower left) shows the I/O characteristics for the controller device ports. Table 6-12 lists the heading and contents for each column of the device-port status region.

Table 6-12 Device-Port Status Columns

Column	Contents
Port	SCSI device ports 1 through 6.
Rq/S	Average request rate for the port during the last update interval. Requests can be up to 32K and generated by host or cache activity.

Table 6-12 Device-Port Status Columns (Continued)

Column	Contents
RdKB/S	Average data transfer rate from the devices on the port (reads) during the last update interval.
WrKB/S	Average data transfer rate to the devices on the port (writes) during the last update interval.
CR	Number of SCSI command resets that occurred since VTDPY was started.
BR	Number of SCSI bus resets that occurred since VTDPY was started.
TR	Number of SCSI target resets that occurred since VTDPY was started.

Checking Unit Status and I/O Activity

Use the cache display to see the status and I/O activity for the logical units configured on the controller (see Figure 6-3). Table 6-13 lists the heading and contents for each column of the device status region.

```
VTDPY> DISPLAY CACHE

HSG80          S/N: ZG92712820 SW: SSDRS-0 HW: E-06
      58.1% Idle      878 KB/S      787 Rq/S          Up: 0 22:10:28

Unit  ASWC      KB/S   Rd%   Wr%   Cm%   HT%   PH%   MS%   Purge BlChd BlHit
P0300  o          0      0     0     0     0     0     0     0     0     0
D0303  o^ b         0      0     0     0     0     0     0     0     0     0
D0304          0      0     0     0     0     0     0     0     0     0
P0400          0      0     0     0     0     0     0     0     0     0
P0401          0      0     0     0     0     0     0     0     0     0
D0402  x^ b         0      0     0     0     0     0     0     0     0     0
```

Figure 6-3. Sample unit status on the cache display

Table 6-13 Unit Status Columns

Column	Contents
Unit	Kind of unit (and its unit number):
	D = disk drive or CD-ROM drive
	P = passthrough device
	? = unknown device type

Table 6-13 Unit Status Columns (Continued)

Column	Contents
A	Availability of the unit:
	a = available to "other controller"
	d = disabled for servicing, offline
	e = mounted for exclusive access by a user
	f = media format error
	i = inoperative
	m = maintenance mode for diagnostic purposes
	o = online. Host can access this unit through "this controller".
	r = rundown with the SET NORUN command
	v = no volume mounted due to lack of media
	x = online. Host can access this unit through "other controller".
	z = currently not accessible to host due to a remote copy condition (ACS V8.5P only)
	= unknown availability
S	Spindle state of the device:
	^ = disk spinning at correct speed; tape loaded
	> = disk spinning up; tape loading
	< = disk spinning down; tape unloading
	v = disk not spinning; tape unloaded
	= unknown spindle state
W	Write-protection state. For disk drives, a W in this column indicates that the device is hardware write-protected. This column is blank for units that comprise other kinds of devices.
C	Caching state of the device:
	a = read, write-back, and read-ahead caching enabled
	b = read and write-back caching enabled
	c = read and read-ahead caching enabled
	p = read-ahead caching enabled
	r = read caching only
	= caching disabled

Table 6-13 Unit Status Columns (Continued)

Column	Contents
KB/S	Average amount of data transferred to and from the unit during the last update interval in 1000-byte increments.
Rd%	Percentage of data transferred between the host and the unit that were read from the unit.
Wr%	Percentage of data transferred between the host and the unit that were written to the unit.
CM%	Percentage of data transferred between the host and the unit that were compared. A compare operation can accompany a read or a write operation, so this column is not the sum of columns Rd% and Wr%.
HT%	Cache-hit percentage for data transferred between the host and the unit.
PH%	Partial cache-hit percentage for data transferred between the host and the unit.
MS%	Cache-miss percentage for data transferred between the host and the unit.
Purge	Number of blocks purged from the cache during the last update interval.
BIChd	Number of blocks added to the cache during the last update interval.
BIHit	Number of blocks hit during the last update interval.

Checking Fibre Channel Link Errors

Use the `VTDPY>DISPLAY HOST` command to also check for any channel link errors (see Figure 6-4).

NOTE: The following section outlines the VTDPY display for “this controller” only. To see other connections, run VTDPY again on the “other controller.”

FIBRE CHANNEL HOST STATUS DISPLAY

```

***** KNOWN HOSTS *****          ***** PORT 1 *****          ***** PORT 2 *****
## NAME      BB FrSz ID/ALPA P S Topology      :FABRIC Topology      :FABRIC
00 BONK2P2   7 2048 210213 2 N Current Status :FABRIC Current Status :FABRIC
01 DADRA22   7 2048 210213 2 N Current ID/ALPA : 21043 Current ID/ALPA : 210613
11 DADRA11   7 2048 210213 1 N Tachyon Status  :   ff Tachyon Status  :   ff
12 BONK1P1   7 2048 210213 1 N Queue Depth    :    6 Queue Depth    :    0
                Busy/QFull Rsp    :    0 Busy/QFull Rsp    :    0
                LINK ERROR COUNTERS          LINK ERROR COUNTERS
                Link Downs          :    1 Link Downs          :    1
                Soft Inits          :    0 Soft Inits          :    0
                Hard Inits          :    0 Hard Inits          :    0
                Loss of Signals      :    0 Loss of Signals      :    0
                Bad Rx Chars         :    3 Bad Rx Chars         :    3
                Loss of Syncs        :    0 Loss of Syncs        :    0
                Link Fails           :    0 Link Fails           :    0
                Received EOFa        :    0 Received EOFa        :    0
                Generated EOFa       :    0 Generated EOFa       :    0
                Bad CRCs             :    0 Bad CRCs             :    0
                Protocol Errors      :    0 Protocol Errors      :    0
                Elastic Errors       :    0 Elastic Errors       :    1

```

Figure 6-4. Sample Fibre Channel host status display

Use the VTDPY>CLEAR command to clear the host display link error counters.

Table 6-14 outlines the “Known Hosts” portion of the Fibre Channel Host Status Display that appears with the VTDPY>DISPLAY HOST command. For a more detailed explanation on certain field labels and their definitions, consult *The Fibre Channel Physical and Signaling Interface Standard* (also known as the FC-PH specification).

**Table 6-14 Fibre Channel Host Status Display —
Known Hosts (Connections)**

Field Label	Description
##	Internal ID
NAME	Refer to the SHOW <i>connection</i> command in <i>Compaq StorageWorks HSG80 Array Controller ACS Version 8.5 CLI Reference Guide</i> .
BB	Buffer-to-buffer credit
FrSz	Frame size
ID/ALPA	Host ID
P	Port number (1 or 2)

Table 6-14 Fibre Channel Host Status Display — Known Hosts (Connections) (Continued)

Field Label	Description
S	Status: N = online F = offline

The following tables detail the remaining portions of the Fibre Channel Host Status Display. Table 6-15 includes the labels that report the status of ports one and two, and Table 6-16 describes the Link Error Counters.

Table 6-15 Fibre Channel Host Status Display — Port Status

Field Label	Description
Topology	LOOP OFFLNE
Current Status	DOWN LOOP STNDBY
Current ID/ALPA	Controller ID
TACHYON Status	This denotes the current state of the TACHYON or Fibre Channel control chip. See "TACHYON Chip Status," page 6-47, for more detail.
Queue Depth	Queue depth shows the instantaneous number of commands at the controller port.
Busy/QFull Rsp	This field represents the total number of QFull/Busy responses sent by the port.

Table 6-16 Fibre Channel Host Status Display — Link Error Counters

Field Label	Description
Link Downs	This field refers to the total number of link down/up transitions.
Soft Inits	Soft initializations are the number of loop initialization caused by this port.
Hard Inits	Hard initializations indicate the number of TACHYON chip resets.
Loss of Signals	Loss of signals show the number of times the Frame Manager detected a low-to-high transition on the InK_unuse signal.

Table 6-16 Fibre Channel Host Status Display — Link Error Counters (Continued)

Field Label	Description
Bad Rx Chars	This field represents the number of times the 8B/10B decode detected an invalid 10-bit code. FC-PH denotes this value as “Invalid Transmission Word during frame reception.” This field may be non-zero after initialization. After initialization, the host should read this value to determine the correct starting value for this error count.
Loss of Syncs	Loss of Sync denotes the number of times the loss of sync is greater than RT_TOV.
Link Fails	This field indicates the number of times the Frame Manager detected a NOS or other initialization protocol failure that caused a transition to the Link Failure state.
Received EOFa	Received EOFa refers to the number of frames containing an EOFa delimiter that the TACHYON chip has received.
Generated EOFa	This field reveals the number of problem frames that the TACHYON chip has received that caused the Frame Manager to attach an EOFa delimiter. Frames that the TACHYON chip discarded due to internal FIFO overflow are not included in this or any other statistic.
Bad CRCs	Bad CRCs denotes the number of bad CRC frames that the TACHYON chip has received.
Protocol Errors	This field indicates the number of protocol errors that the Frame Manager has detected.
Elastic Errors	Elastic errors reveal the timing difference between the receive and transmit clocks and usually indicate cable pulls.

TACHYON Chip Status

The number that appears in the TACHYON Status field represents the current state of the TACHYON or Fibre Channel control chip. It consists of a two-digit hexadecimal number, the first of which is explained in Table 6-17. The second digit is outlined in Table 6-18. Refer to the Hewlett-Packard© TACHYON user manual for a more detailed explanation of the TACHYON chip definitions.

Table 6-17 First Digit on the TACHYON Chip

State	Definition	State	Definition
0	MONITORING	8	INITIALIZING
1	ARBITRATING	9	O_I INIT FINISH
2	ARBITRATION WON	A	O_I PROTOCOL
3	OPEN	B	O_I LIP RECEIVED
4	OPENED	C	HOST CONTROL
5	XMITTED CLOSE	D	LOOP FAIL
6	RECEIVED CLOSE	F	OLD PORT
7	TRANSFER		

Table 6-18 Second Digit on the TACHYON Chip

State	Definition	State	Definition
0	OFFLINE	6	LR2
1	OL1	7	LR3
2	OL2	9	LF1
3	OL3	A	LF2
5	LR1	F	ACTI VE

Checking Runtime Status of Remote Copy Sets

Use the remote display to see the runtime status of all remote copy sets (see Figure 6-5). This feature is only supported in ACS V8.5P.

```
VTDPY> DISPLAY REMOTE

COPY SET      TARGET      C INIT U  Kb/S  ASSOC SET LOG  U  Kb/S  LS  %LOG %MRG %CPY
===== = ===== = ===== = ===== = ===== = ===== = ===== = ===== = ===== = =====
RCS2          G213_TAR/D52 D D2   o   920  ASC1      D98 o  ***** LG   67%  0% 100%
RCS3          G213_TAR/D0  D D3   x  ***** ASC2      D99 x  ***** **  ***%  ***%  ***%
RCS4          G213_TAR/D0  D D4   x  ***** ASC3      D97 x  ***** **  ***%  ***%  ***%
RCS5          NO TARGETS   * D5   x  ***** ***** **  ***%  ***%  ***%
RCS7          G213_TAR/D57 D D7   o   714  ASC4      D96 o   336  LG   49%  0% 100%
RCS8          G213_TAR/D0  D D8   x  ***** ASC2      D99 x  ***** **  ***%  ***%  ***%
```

Figure 6-5. Sample runtime status in the remote display (ACS V8.5P only)

Table 6-19 provides a description of the remote display column headings and possible entries under each column.

Table 6-19 Remote Display Columns—ACS V8.5P only	
Column	Contents
COPY SET	Remote copy set name
TARGET	Target connection name and target unit number
C	Connection status:
U	= connection Up (online)
D	= connection Down (offline)

Table 6-19 Remote Display Columns—ACS V8.5P only (Continued)

Column	Contents
INIT	Initiator unit number
U	Availability of the unit:
	a = available to "other controller"
	d = disabled for servicing, offline
	e = mounted for exclusive access by a user
	f = media format error
	i = inoperative
	m = maintenance mode for diagnostic purposes
	o = online. Host can access this unit through "this controller".
	r = rundown with the SET NORUN command
	v = no volume mounted due to lack of media
	x = online. Host can access this unit through "other controller".
	z = currently not accessible to host due to a remote copy condition
	= unknown availability
Kb/S	Total initiator unit bandwidth in Kb per second
ASSOC SET	Association set name
LOG	Write history log unit number
U	Log unit status: uses the same codes as "U - Availability of the unit"
Kb/S	Total log unit bandwidth in Kb per second
LS	Log State:
	LG = logging
	MG = merging
	CP = copying
	NR = normal
	NZ = normalizing
%LOG	Percent of the write history log unit available for use / remaining
%MRG	Percent of merge process completed
%CPY	Percent of copy process completed

DILX

Checking for Disk Drive Problems

Use DILX to check the data-transfer capability of disk drives. DILX generates intense read/write loads to the disk drive while monitoring drive performance and status. Run DILX on as many disk drives as desired, but since this utility creates substantial I/O loads on the controller, *Compaq* recommends stopping host-based I/O during the test.

IMPORTANT: DILX cannot be run on remote copy sets (ACS V8.5P only).

Finding a Disk Drive in the Subsystem

Use the following steps to find a disk drive or device in the subsystem:

1. Connect a PC or a terminal to the controller maintenance port.
2. Show the devices that are configured on the controller with the following command:

```
SHOW DEVICES
```

3. Find the device in the enclosure with the following command:

```
LOCATE device-name
```

This command causes the device LED to blink continuously.

4. Enter the following command to turn off the LED:

```
LOCATE CANCEL
```

Testing the Read Capability of a Disk Drive

Use the following steps to test the read capability of a disk drive:

1. From a host console, dismount the logical unit that contains the disk drive being tested.
2. Connect a terminal to the controller maintenance port that accesses the disk drive being tested.
3. Run DILX with the following command:

```
RUN DILX
```

IMPORTANT: Use the auto-configure option if testing the read and write capabilities of every disk drive in the subsystem.

4. Decline the auto-configure option to allow testing of a specific disk drive.
5. Accept the default test settings and run the test in read-only mode.
6. Enter the unit number of the specific disk drive to test.
For example: to test D107, enter the number 107.
7. If testing more than one disk drive, enter the appropriate unit numbers when prompted. Otherwise, enter “n” to start the test.

NOTE: Use the control sequences listed in Table 6-20 to control DILX during the test.

Table 6-20 DILX Control Sequences

Command	Action
Ctrl/C	Terminates the test.
Ctrl/G	Displays the performance summary for the current test and continue testing.
Ctrl/Y	Terminates the test and exits DILX.

Testing the Read and Write Capabilities of a Disk Drive

Run a DILX Basic Function test to test the read and write capability of a disk drive. During the Basic Function test, DILX runs the following four tests.

NOTE: DILX repeats the last three tests until the time entered in step 6 on page 6-53 expires.

- **Write test.** Writes specific patterns of data to the disk drive (see Table 6-21). DILX does not repeat this test.
- **Random I/O test.** Simulates typical I/O activity by issuing read, write, access, and erase commands to randomly-chosen LBNS. The ratio of these commands can be manually set, as well as the percentage of read and write data that are compared throughout this test. This test takes 6 minutes.
- **Data-transfer test.** Tests throughput by starting at an LBN and transferring data to the next unwritten LBN. This test takes 2 minutes.
- **Seek test.** Stimulates head motion on the disk drive by issuing single-sector erase and access commands. Each I/O uses a different track on each subsequent transfer. The ratio of access and erase commands can be manually set. This test takes 2 minutes.

Table 6-21 Data Patterns for Phase 1: Write Test

Pattern	Pattern in Hexadecimal Numbers
1	0000
2	8B8B
3	3333
4	3091
5	0001, 0003, 0007, 000F, 001F, 003F, 007F, 00FF, 01FF, 03FF, 07FF, 0FFF, 1FFF, 3FFF, 7FFF
6	F1E, FFFC, FFFC, FFFC, FFE0, FFE0, FFE0, FFE0, FE00, FC00, F800, F000, F000, C000, 8000, 0000
7	0000, 0000, 0000, FFFF, FFFF, FFFF, 0000, 0000, FFFF, FFFF, 0000, FFFF, 0000, FFFF, 0000, FFFF
8	B6D9
9	5555, 5555, 5555, AAAA, AAAA, AAAA, 5555, 5555, AAAA, AAAA, 5555, AAAA, 5555, AAAA, 5555, AAAA, 5555
10	DB6C
11	2D2D, 2D2D, 2D2D, D2D2, D2D2, D2D2, 2D2D, 2D2D, D2D2, D2D2, 2D2D, D2D2, 2D2D, D2D2, 2D2D, D2D2
12	6DB6
13	0001, 0002, 0004, 0008, 0010, 0020, 0040, 0080, 0100, 0200, 0400, 0800, 1000, 2000, 4000, 8000
14	F1E, FFFD, FFFB, FFF7, FFEF, FFDF, FFBF, FF7F, FEFF, FDFE, FBFF, F7FF, EFFF, BFFF, DFFF, 7FFF
15	DB6D, B6DB, 6DB6, 6DB6, B6DB, 6DB6, DB6D, B6DB, 6DB6, DB6D, B6DB, 6DB6, DB6D
16	3333, 3333, 3333, 1999, 9999, 9999, B6D9, B6D9, B6D9, B6D9, FFFF, FFFF, 0000, 0000, DB6C, DB6C
17	9999, 1999, 699C, E99C, 9921, 9921, 1921, 699C, 699C, 0747, 0747, 0747, 699C, E99C, 9999, 9999
18	FFFF

Use the following steps to test the read and write capabilities of a specific disk drive:

1. From a host console, dismount the logical unit which contains the disk drive that needs testing.
2. Connect a terminal to the controller maintenance port that accesses the disk drive being tested.
3. Run DILX with the following command:

```
RUN DILX
```

IMPORTANT: Use the auto-configure option if testing the read and write capabilities of every disk drive in the subsystem.

4. Decline the auto-configure option to allow testing of a specific disk drive.
5. Decline the default settings.

NOTE: To ensure that DILX accesses the entire disk space, enter 120 minutes or more in the next step. The default setting is 10 minutes.

6. Enter the number of minutes desired for running the DILX Basic Function test.
7. Enter the number of minutes between the display of performance summaries.
8. Choose to include performance statistics in the summary.
9. Choose to display both hard and soft errors.
10. Choose to display the hex dump.
11. Accept the hard-error limit default.
12. Accept the soft-error limit default.
13. Accept the queue depth default.
14. Choose option 1 to run a Basic Function test.
15. Enable phase 1, the write test.

DILX issues the balance as write requests.
17. Choose ALL for the data patterns that DILX issues for write requests.
18. Perform the initial write pass.
19. Allow DILX to compare the read and write data.
20. Accept the default percentage of reads and writes that DILX compares.
21. Enter the unit number of the specific disk drive to tested.

For example: to test D107, enter the number 107.
22. If testing more than one disk drive, enter the appropriate unit numbers when prompted. Otherwise, enter "n" to start the test.

NOTE: Use the command sequences shown in Table 6-20 to control the write test.

DILX Error Codes

Table 6-22 explains the error codes that DILX might display during and after testing.

Table 6-22 DILX Error Codes	
Error Code	Explanation
1	Illegal Data Pattern Number found in data pattern header. DILX read data from the disk and discovered that the data did not conform to the pattern in which it was previously written.
2	No write buffers correspond to data pattern. DILX read a legal data pattern from the disk, but because no write buffers correspond to the pattern, the data must be considered corrupt.
3	Read data does not match write buffer. DILX compared the read and write data and discovered that they did not correspond.

HSUTIL

Use the HSUTIL utility to upgrade the firmware on disk drives in the subsystem and to format disk drives. See Chapter 5 for more information on using HSUTIL. While formatting disk drives or installing new firmware, HSUTIL might produce one or more of the messages shown in Table 6-23 (many of the self-explanatory messages have been omitted).

Table 6-23 HSUTIL Messages and Inquiries	
Message	Description
Insufficient resources.	HSUTIL cannot find or perform the operation because internal controller resources are not available.
Unable to change operation mode to maintenance for unit.	HSUTIL was unable to put the source single-disk drive unit into maintenance mode to enable formatting or code load.
Unit successfully allocated.	HSUTIL has allocated the single-disk drive unit for code load operation. At this point, the unit and its associated device are not available for other subsystem operations.
Unable to allocate unit.	HSUTIL could not allocate the single-disk drive unit. An accompanying message explains the reason.
Unit is owned by another sysop.	Device cannot be allocated because it is being used by another subsystem function or local program.

Table 6-23 HSUTIL Messages and Inquiries (Continued)

Message	Description
Unit is in maintenance mode.	Device cannot be formatted or code loaded because it is being used by another subsystem function or local program.
Exclusive access is declared for unit.	Another subsystem function has reserved the unit shown.
The other controller has exclusive access declared for unit.	The companion controller has locked out this controller from accessing the unit shown.
The RUNSTOP_SWITCH is set to RUN_DISABLED for unit.	The RUNNORUN unit indicator for the unit shown is set to NORUN; the disk cannot spin up.
What BUFFER SIZE, (in BYTES), does the drive require (2048, 4096, 8192) [8192]?	HSUTIL detects that an unsupported device has been selected as the target device and the firmware image requires multiple SCSI Write Buffer commands. Specify the number of bytes to be sent in each Write Buffer command. The default buffer size is 8192 bytes. A firmware image of 256 K, for example, can be code loaded in 32 Write Buffer commands, each transferring 8192 bytes.
What is the TOTAL SIZE of the code image in BYTES [<i>device default</i>]?	HSUTIL detects that an unsupported device has been selected as the target device. Enter the total number of bytes of data to be sent in the code load operation.
Does the target device support only the download microcode and save?	HSUTIL detects that an unsupported device has been selected as the target device. Specify whether the device supports the SCSI Write Buffer command download and save function.
Should the code be downloaded with a single write buffer command?	HSUTIL detects that an unsupported device has been selected as the target device. Indicate whether to download the firmware image to the device in one or more contiguous blocks, each corresponding to one SCSI Write Buffer command.

CONFIG Utility

Use the CONFIG utility to add one or more storage devices to the subsystem. This utility checks the device ports for new disk drives, then adds them to the controller configuration and automatically names them.

CLCP Utility

Use the CLCP utility to upgrade the controller software and the EMU software. Also use it to patch the controller software. When installing a new controller, the correct (or current) software version and patch numbers must be available. See Chapter 5 for more information about using this utility.

NOTE: Only *Compaq* field service personnel are authorized to upload EMU microcode updates. Contact the Customer Service Center (CSC) for directions in obtaining the appropriate EMU microcode and installation guide.

CLONE Utility

Use the CLONE utility to duplicate the data on any unpartitioned single-disk unit, stripeset, mirrorset, or striped mirrorset. Back up the cloned data while the actual storageset remains online. When the cloning operation is done, back up the clones rather than the storageset or single-disk unit, which can continue to service its I/O load. When cloning a mirrorset, the CLONE utility does not need to create a temporary mirrorset. Instead, it adds a temporary member to the mirrorset and copies the data onto this new member.

The CLONE utility creates a temporary, two-member mirrorset for each member in a single-disk unit or stripeset. Each temporary mirrorset contains one disk drive from the unit being cloned and one disk drive onto which the CLONE utility copies the data. During the copy operation, the unit remains online and active so the clones contain the most up-to-date data.

After the CLONE utility copies the data from the members to the clones, it restores the unit to its original configuration and creates a clone unit for backup purposes.

FRUTIL

Use FRUTIL to replace a failed controller (in a dual-redundant configuration) without shutting down the subsystem. Also use this menu-driven utility to replace cache modules and external cache batteries. See Chapter 2 for a more detailed explanation of how FRUTIL is used during a replacement process.

IMPORTANT: FRUTIL cannot be run in remote copy set environments while I/O is in progress to the target side due to host write and normalization (ACS V8.5P only).

CHVSN Utility

The CHVSN utility generates a new volume serial number (called *VSN*) for the specified device and writes it on the media. It is a way to eliminate duplicate volume serial numbers and to rename duplicates with different volume serial numbers.

NOTE: Only *Compaq* authorized service personnel can use this utility.

Chapter 7

Event Reporting: Templates and Codes

This chapter describes the event codes that the fault management software provides for spontaneous events and last failure events.

The HSG80 controller uses various codes to report different types of events, and these codes are presented in template displays. Instance codes are unique codes that identify events, additional sense code (ASC) and additional sense code qualifier (ASCQ) codes explain the cause of the events, and last failure codes describe unrecoverable conditions that might occur with the controller.

Passthrough Device Reset Event Sense Data Response

Events reported by passthrough devices during host/device operations are conveyed directly to the host system without intervention or interpretation by the HSG80 controller, with the exception of device sense data that is truncated to 160 bytes when it exceeds 160 bytes.

Events related to passthrough device recognition, initialization, and SCSI bus communication events, resulting in a reset of a passthrough device by the HSG80 controller, are reported using standard SCSI Sense Data (see Table 7-1). For all other events, refer to the templates contained within this section.

- Instance codes (byte offsets 8–11) are detailed in the “Instance Codes” section on page 7-20.
- ASC and ASCQ codes (byte offsets 12 and 13) are detailed in the “ASC/ASCQ Codes” section on page 7-17.

↓ offset	bit →	7	6	5	4	3	2	1	0
0		Valid		Error Code					
1		Segment							
2		FM	EOM	ILI	Reserved	Sense Key			
3-6		Information							
7		Additional Sense Length							
8-11		Instance Code							
12		Additional Sense Code (ASC)							
13		Additional Sense Code Qualifier (ASCQ)							
14		Field Replaceable Unit Code							
15		SKSV	Sense Key Specific						
16		Sense Key Specific							
17		Sense Key Specific							

Last Failure Event Sense Data Response (Template 01)

Unrecoverable conditions, detected by either software or hardware, and certain operator-initiated conditions terminate HSG80 controller operation. In most cases, following such a termination, the controller attempts to restart (that is, reboot) with hardware components and software data structures initialized to the states necessary to perform normal operations (see Table 7-2). Following a successful restart, the condition that caused controller operation to terminate is signaled to all host systems on all logical units.

NOTE: For ACS V8.5P configurations, last failure events generated by the target will not be signaled to any host unless the host has a direct connection to the target—which is not through the initiator. In addition, these events might not appear on the initiator.

- ASC and ASCQ codes (byte offsets 12 and 13) are detailed in the “ASC/ASCQ Codes” section on page 7-17.
- Instance codes (byte offsets 32-35) are detailed in the “Instance Codes” section on page 7-20.
- Last failure codes (byte offsets 104-107) are detailed in the “Last Failure Codes” section on page 7-45.

Table 7-2 Template 01—Last Failure Event Sense Data Response Format

↓ offset	bit →	7	6	5	4	3	2	1	0	
0		Unused	Error Code							
1		Unused								
2		Unused				Sense Key				
3-6		Unused								
7		Additional Sense Length								
8-11		Unused								
12		Additional Sense Code (ASC)								
13		Additional Sense Code Qualifier (ASCQ)								
14		Unused								
15-17		Unused								
18-31		Reserved								
32-35		Instance Code								
36		Template								
37		Template Flags								
38-53		Reserved								
54-69		Controller Board Serial Number								
70-73		Controller Software Revision Level								
74		Reserved or Patch Version (TM2)								
75		Reserved								
76		LUN Status								
77-103		Reserved								
104-107		Last Failure Code								
108-111		Last Failure Parameter [0]								
112-115		Last Failure Parameter [1]								
116-119		Last Failure Parameter [2]								
120-123		Last Failure Parameter [3]								
124-127		Last Failure Parameter [4]								
128-131		Last Failure Parameter [5]								
132-135		Last Failure Parameter [6]								
136-139		Last Failure Parameter [7]								
140-159		Reserved								

Multiple-Bus Failover Event Sense Data Response (Template 04)

The HSG80 SCSI Host Interconnect Services software component reports Multiple Bus Failover events via the Multiple Bus Failover Event Sense Data Response (see Table 7-3). The error or condition is signaled to all host systems on all logical units.

- ASC and ASCQ codes (byte offsets 12 and 13) are detailed in the “ASC/ASCQ Codes” section on page 7-17.
- Instance codes (byte offsets 32-35) are detailed in the “Instance Codes” section on page 7-20.

Table 7-3 Template 04—Multiple-Bus Failover Event Sense Data Response Format

↓ offset	bit →	7	6	5	4	3	2	1	0
0		Unused	Error Code						
1		Unused							
2		Unused				Sense Key			
3-6		Unused							
7		Additional Sense Length							
8-11		Unused							
12		Additional Sense Code (ASC)							
13		Additional Sense Code Qualifier (ASCQ)							
14		Unused							
15-17		Unused							
18-26		Reserved							
27		Failed Controller Target Number							
28-31		Affected LUNs							
32-35		Instance Code							
36		Template							
37		Template Flags							
38-53		Other Controller Board Serial Number							
54-69		Controller Board Serial Number							
70-73		Controller Software Revision Level							
74		Reserved or Patch Version (TM2)							
75		Reserved							
76		LUN Status							

Table 7-3 Template 04—Multiple-Bus Failover Event Sense Data Response Format (Continued)

↓ offset	bit →	7	6	5	4	3	2	1	0
77–103		Reserved							
104–131		Affected LUNs Extension (TMO)							
132–159		Reserved							

Failover Event Sense Data Response (Template 05)

The HSG80 controller Failover Control software component reports errors and other conditions encountered during redundant controller communications and failover operation via the Failover Event Sense Data Response (see Table 7-4). The error or condition is signaled to all host systems on all logical units.

- ASC and ASCQ codes (byte offsets 12 and 13) are detailed in the “ASC/ASCQ Codes” section on page 7-17.
- Instance codes (byte offsets 32–35) are detailed in the “Instance Codes” section on page 7-20.
- Last failure codes (byte offsets 104–107) are detailed in the “Last Failure Codes” section on page 7-45.

Table 7-4 Template 05—Failover Event Sense Data Response Format

↓ offset	bit →	7	6	5	4	3	2	1	0	
0		Unused	Error Code							
1		Unused								
2		Unused				Sense Key				
3–6		Unused								
7		Additional Sense Length								
8–11		Unused								
12		Additional Sense Code (ASC)								
13		Additional Sense Code Qualifier (ASCQ)								
14		Unused								
15–17		Unused								
18–31		Reserved								
32–35		Instance Code								
36		Template								
37		Template Flags								

Table 7-4 Template 05—Failover Event Sense Data Response Format (Continued)

↓ offset	bit →	7	6	5	4	3	2	1	0
38–53		Reserved							
54–69		Controller Board Serial Number							
70–73		Controller Software Revision Level							
74		Reserved or Patch Version (TM2)							
75		Reserved							
76		LUN Status							
77–103		Reserved							
104–107		Last Failure Code							
108–111		Last Failure Parameter [0]							
112–115		Last Failure Parameter [1]							
116–119		Last Failure Parameter [2]							
120–123		Last Failure Parameter [3]							
124–127		Last Failure Parameter [4]							
128–131		Last Failure Parameter [5]							
132–135		Last Failure Parameter [6]							
136–139		Last Failure Parameter [7]							
140–159		Reserved							

Nonvolatile Parameter Memory Component Event Sense Data Response (Template 11)

The HSG80 controller executive software component reports errors detected while accessing a nonvolatile parameter memory component via the Nonvolatile Parameter Memory Component Event Sense Data Response (see Table 7-5). The error is signaled to all host systems on all logical units.

- ASC and ASCQ codes (byte offsets 12 and 13) are detailed in the “ASC/ASCQ Codes” section on page 7-17.
- Instance codes (byte offsets 32–35) are detailed in the “Instance Codes” section on page 7-20.

Table 7-5 Template 11—Nonvolatile Parameter Memory Component Event Sense Data Response Format

↓ offset	bit →	7	6	5	4	3	2	1	0
0		Unused	Error Code						
1		Unused							
2		Unused				Sense Key			
3-6		Unused							
7		Additional Sense Length							
8-11		Unused							
12		Additional Sense Code (ASC)							
13		Additional Sense Code Qualifier (ASCQ)							
14		Unused							
15-17		Unused							
18-31		Reserved							
32-35		Instance Code							
36		Template							
37		Template Flags							
38-53		Reserved							
54-69		Controller Board Serial Number							
70-73		Controller Software Revision Level							
74		Reserved or Patch Version (TM2)							
75		Reserved							
76		LUN Status							
77-103		Reserved							
104-107		Memory Address							
108-111		Byte Count							
112-114		Number of Times Written							
115		Undefined							
116-159		Reserved							

Backup Battery Failure Event Sense Data Response (Template 12)

The HSG80 controller Value Added Services software component reports backup battery failure conditions for the various hardware components that use a battery to maintain state during power failures via the Backup Battery Failure Event Sense Data Response (see Table 7-6). The failure condition is signaled to all host systems on all logical units.

- ASC and ASCQ codes (byte offsets 12 and 13) are detailed in the “ASC/ASCQ Codes” section on page 7-17.
- Instance codes (byte offsets 32-35) are detailed in the “Instance Codes” section on page 7-20.

Table 7-6 Template 12—Backup Battery Failure Event Sense Data Response Format

↓ offset	bit →	7	6	5	4	3	2	1	0
0		Unused	Error Code						
1		Unused							
2		Unused				Sense Key			
3-6		Unused							
7		Additional Sense Length							
8-11		Unused							
12		Additional Sense Code (ASC)							
13		Additional Sense Code Qualifier (ASCQ)							
14		Unused							
15-17		Unused							
18-31		Reserved							
32-35		Instance Code							
36		Template							
37		Template Flags							
38-53		Reserved							
54-69		Controller Board Serial Number							
70-73		Controller Software Revision Level							
74		Reserved or Patch Version (TM2)							
75		Reserved							
76		LUN Status							
77-103		Reserved							

Table 7–6 Template 12—Backup Battery Failure Event Sense Data Response Format (Continued)

↓ offset	bit →	7	6	5	4	3	2	1	0
104–107		Memory Address							
108–159		Reserved							

Subsystem Built-In Self Test Failure Event Sense Data Response (Template 13)

The HSG80 controller Subsystem Built-In Self Test software component reports errors detected during test execution via the Subsystem Built-In Self Test Failure Event Sense Data Response (see Table 7–7). The error is signaled to all host systems on all logical units.

- ASC and ASCQ codes (byte offsets 12 and 13) are detailed in the “ASC/ASCQ Codes” section on page 7–17.
- Instance codes (byte offsets 32–35) are detailed in the “Instance Codes” section on page 7–20.

Table 7–7 Template 13—Subsystem Built-In Self Test Failure Event Sense Data Response Format

↓ offset	bit →	7	6	5	4	3	2	1	0	
0		Unused	Error Code							
1		Unused								
2		Unused				Sense Key				
3–6		Unused								
7		Additional Sense Length								
8–11		Unused								
12		Additional Sense Code (ASC)								
13		Additional Sense Code Qualifier (ASCQ)								
14		Unused								
15–17		Unused								
18–31		Reserved								
32–35		Instance Code								
36		Template								
37		Template Flags								
38–53		Reserved								

Table 7-7 Template 13—Subsystem Built-In Self Test Failure Event Sense Data Response Format (Continued)

↓ offset	bit →	7	6	5	4	3	2	1	0
54–69		Controller Board Serial Number							
70–73		Controller Software Revision Level							
74		Reserved or Patch Version (TM2)							
75		Reserved							
76		LUN Status							
77–103		Reserved							
104–105		Undefined							
106		Header Type							
107		Header Flags							
108		TE							
109		Test Number							
110		Test Command							
111		Test Flags							
112–113		Error Code							
114–115		Return Code							
116–119		Address of Error							
120–123		Expected Error Data							
124–127		Actual Error Data							
128–131		Extra Status 1							
132–135		Extra Status 2							
136–139		Extra Status 3							
140–159		Reserved							

Memory System Failure Event Sense Data Response (Template 14)

The HSG80 controller Memory Controller Event Analyzer software component and the Cache Manager, part of the Value Added software component, report the occurrence of memory errors via the Memory System Failure Event Sense Data Response (see Table 7-8). The error is signaled to all host systems on all logical units.

- ASC and ASCQ codes (byte offsets 12 and 13) are detailed in the “ASC/ASCQ Codes” section on page 7-17.
- Instance codes (byte offsets 32–35) are detailed in the “Instance Codes” section on page 7-20.

Table 7-8 Template 14—Memory System Failure Event Sense Data Response Format

↓ offset	bit →	7	6	5	4	3	2	1	0	
0		Unused	Error Code							
1		Unused								
2		Unused				Sense Key				
3-6		Unused								
7		Additional Sense Length								
8-11		Unused								
12		Additional Sense Code (ASC)								
13		Additional Sense Code Qualifier (ASCQ)								
14		Unused								
15-17		Unused								
18-19		Reserved								
20-23		Reserved or RDR2 (TM1)								
24-27		Reserved or RDEAR (TM1)								
28-31		Reserved								
32-35		Instance Code								
36		Template								
37		Template Flags								
38-39		Reserved								
40-43		Reserved or FXPSCR (TM1)								
44-47		Reserved or FXCSR (TM1)								
48-51		Reserved or FXCCSR (TM1)								
52-53		Reserved								
54-69		Controller Board Serial Number								
70-73		Controller Software Revision Level								
74		Reserved or Patch Version (TM2)								
75		Reserved								
76		LUN Status								
77-79		Reserved								
80-83		Reserved or FXPAEC (TM1)								
84-87		Reserved or FXCAEC (TM1)								
88-91		Reserved or FXPAEP (TM1)								
92-95		Reserved or CHC (TM0) or FXCAEP (TM1)								
96-99		Reserved or CMC (TM0) or CFW (TM1)								
100-103		Reserved or DSR2 (TM0) or RRR (TM1)								

Table 7-8 Template 14—Memory System Failure Event Sense Data Response Format (Continued)

↓ offset	bit →	7	6	5	4	3	2	1	0
104–107		Memory Address							
108–111		Byte Count							
112–115		DSR or PSR (TM1)							
116–119		CSR or CSR (TM1)							
120–123		DCSR or EAR (TM1)							
124–127		DER or EDR1 (TM1)							
128–131		EAR or EDR0 (TM1)							
132–135		EDR or ICR (TM1)							
136–139		ERR or IMR (TM1)							
140–143		RSR or DID (TM1)							
144–147		RDRO							
148–151		RDR1							
152–155		WDR0							
156–159		WDR1							

Device Services Non-Transfer Error Event Sense Data Response (Template 41)

The HSG80 controller Device Services software component reports errors detected while performing non-transfer work related to disk (including CD-ROM and optical memory) device operations via the Device Services Non-Transfer Event Sense Data Response (see Table 7-9). If the error occurred during the execution of a command issued by a HSG80 controller software component, the error is signaled to all host systems on all logical units.

- ASC and ASCQ codes (byte offsets 12 and 13) are detailed in the “ASC/ASCQ Codes” section on page 7-17.
- Instance codes (byte offsets 32–35) are detailed in the “Instance Codes” section on page 7-20.

Table 7-9 Template 41—Device Services Non-Transfer Error Event Sense Data Response Format

↓ offset	bit →	7	6	5	4	3	2	1	0	
0		Unused	Error Code							
1		Unused								
2		Unused				Sense Key				
3-6		Unused								
7		Additional Sense Length								
8-11		Unused								
12		Additional Sense Code (ASC)								
13		Additional Sense Code Qualifier (ASCQ)								
14		Unused								
15-17		Unused								
18-31		Reserved								
32-35		Instance Code								
36		Template								
37		Template Flags								
38-53		Reserved								
54-69		Controller Board Serial Number								
70-73		Controller Software Revision Level								
74		Reserved or Patch Version (TM2)								
75		Reserved								
76		LUN Status								
77-103		Reserved								
104		Associated Port								
105		Associated Target								
106		Associated Additional Sense Code								
107		Associated Additional Sense Code Qualifier								
108-159		Reserved								

Disk Transfer Error Event Sense Data Response (Template 51)

The HSG80 controller Device Services and Value Added Services software components report errors detected while performing work related to disk (including CD-ROM and optical memory) device transfer operations via the Disk Transfer Error Event Sense Data Response (see Table 7-10). If the error occurred during the execution of a command issued by a HSG80 controller software component, the error is signaled to all host systems on the logical unit associated with the physical unit that reported the error.

- ASC and ASCQ codes (byte offsets 12 and 13) are part of the Standard Sense Data and detailed in the “ASC/ASCQ Codes” section on page 7-17.
- Instance codes (byte offsets 32-35) are detailed in the “Instance Codes” section on page 7-20.

**Table 7-10 Template 51—Disk Transfer Error Event Sense Data Response
Format**

↓ offset	bit →	7	6	5	4	3	2	1	0
0-17		Standard Sense Data							
18-19		Reserved							
20		Total Number of Errors							
21		Total Retry Count							
22-25		ASC/ASCQ Stack							
26-28		Device Locator							
29-31		Reserved							
32-35		Instance Code							
36		Template							
37		Template Flags							
38		Reserved							
39		Command OpCode							
40		Sense Data Qualifier							
41-50		Original CDB							
51		Host ID							
52-53		Reserved							
54-69		Controller Board Serial Number							
70-73		Controller Software Revision Level							
74		Reserved or Patch Version (TM2)							
75		Reserved							
76		LUN Status							

Table 7-10 Template 51—Disk Transfer Error Event Sense Data Response Format (Continued)

↓ offset	bit →	7	6	5	4	3	2	1	0
77-78		Reserved							
79-82		Device Firmware Revision Level							
83-98		Device Product ID							
99-100		Reserved							
101		Device Type							
102-103		Reserved							
104-121		Device Sense Data							
122-159		Reserved							

Data Replication Manager Services Event Sense Response (Template 90)

This section only applies to ACS version 8.5P. The HSG80 Data Replication Manager Services software component reports events via the Data Replication Manager Services Event Sense Data Response.

With Data Replication Manager, fault management events are reported using Template 90, shown in Table 7-11. The error is signaled to all host systems on the logical unit associated with the initiator unit that reported the error.

- ASC and ASCQ codes (byte offsets 12 and 13) are detailed in the “ASC/ASCQ Codes” section on page 7-17.
- Instance codes (byte offsets 32-35) are detailed in the “Instance Codes” section on page 7-20.

Table 7-11 Template 90—Data Replication Manager Services Event Sense Data Response Format (ACS V8.5P only)

↓ offset	bit →	7	6	5	4	3	2	1	0
0	Unused	Error Code							
1		Unused							
2		Unused				Sense Key			
3-6		Unused							
7		Additional Sense Length							
8-11		Unused							
12		Additional Sense Code (ASC)							

Table 7-11 Template 90—Data Replication Manager Services Event Sense Data Response Format (ACS V8.5P only) (Continued)

↓ offset	bit →	7	6	5	4	3	2	1	0
13	Additional Sense Code Qualifier (ASCQ)								
14	Unused								
15-17	Unused								
18-27	Reserved								
28-31	Reserved or Log Unit Number (TM0)								
32-35	Instance Code								
36	Template								
37	Template Flags								
38-53	Target Controller Board Serial Number								
54-69	Controller Board Serial Number								
70-73	Controller Software Revision Level								
74	Reserved or Patch Version (TM2)								
75	Reserved								
76	LUN Status								
77-79	Reserved								
80-95	Initiator WWLID								
96-103	Initiator Node Name								
104-107	Initiator Unit Number								
108-123	Target WWLID								
124-131	Target Node Name								
132-135	Target Unit Number								
136-139	Number of Targets								
140-148	Remote Copy Set Name								
149-157	Reserved or Association Set Name (TM0)								
158-159	Reserved								

ASC/ASCQ Codes

Table 7-12 lists HSG80-specific SCSI ASC and ASCQ codes. These codes are Template-specific and appear at byte offsets 12 and 13.

NOTE: Additional codes that are common to all SCSI devices can be found in the SCSI specification.

Table 7-12 ASC and ASCQ Codes (Sheet 1 of 3)		
ASC Code	ASCQ Code	Description
04	80	Logical unit is disaster tolerant failsafe locked (inoperative).
3F	85	Test Unit Ready or Read Capacity Command failed.
3F	87	Drive failed by a Host Mode Select command.
3F	88	Drive failed due to a deferred error reported by drive.
3F	90	Unrecovered Read/Write error.
3F	C0	No response from one or more drives.
3F	C2	NV memory and drive metadata indicate conflicting drive configurations.
3F	CE	UPS TMW before AC_FAIL.
3F	D2	Synchronous Transfer Value differences between drives.
80	00	Forced error on Read.
82	01	No Command control structures available.
84	04	Command failed - SCSI ID verification failed.
85	05	Data returned from drive is invalid.
89	00	Request Sense command to drive failed.
8A	00	Illegal command for pass through mode.
8C	04	Data transfer request error.
8F	00	Premature completion of a drive command.
93	00	Drive returned vendor unique sense data.
A0	00	Last failure event report.
A0	01	Nonvolatile parameter memory component event report.
A0	02	Backup battery failure event report.
A0	03	Subsystem built-in self test failure event report.
A0	04	Memory system failure event report.
A0	05	Failover event report.

Table 7-12 ASC and ASCQ Codes (Sheet 2 of 3)

ASC Code	ASCQ Code	Description
A0	07	RAID membership event report.
A0	08	Multiple Bus failover event.
A0	09	Multiple Bus failback event.
A0	0A	Disaster Tolerance failsafe error mode can now be enabled.
A1	00	Shelf OK is not properly asserted.
A1	01	Unable to clear SWAP interrupt. Interrupt disabled.
A1	02	Swap interrupt re-enabled.
A1	03	Asynchronous SWAP detected.
A1	04	Controller shelf OK is not properly asserted.
A1	0A	EMU fault: Power Supplies not OK.
A1	0B	EMU fault: Fans not OK.
A1	0C	EMU fault: Temperature not OK.
A1	0D	EMU fault: External Air Sense not OK.
A1	10	Power supply fault is now fixed.
A1	11	Fans fault is now fixed.
A1	12	Temperature fault is now fixed.
A1	13	External Air Sense fault is now fixed.
A1	14	EMU and cabinet now available.
A1	15	EMU and cabinet now unavailable.
A2	00	Data Replication Manager connection event.
A2	01	Remote Copy Set membership event.
B0	00	Command timeout.
B0	01	Watchdog timer timeout.
D0	01	Disconnect timeout.
D0	02	Chip command timeout.
D0	03	Byte transfer timeout.
D1	00	Bus errors.
D1	02	Unexpected bus phase.
D1	03	Disconnect expected.
D1	04	ID Message not sent.
D1	05	Synchronous negotiation error.

Table 7-12 ASC and ASCQ Codes (Sheet 3 of 3)

ASC Code	ASCQ Code	Description
D1	07	Unexpected disconnect.
D1	08	Unexpected message.
D1	09	Unexpected Tag message.
D1	0A	Channel busy.
D1	0B	Device initialization failure. Device sense data available.
D2	00	Miscellaneous SCSI driver error.
D2	03	Device services had to reset the bus.
D3	00	Drive SCSI chip reported gross error.
D4	00	Non-SCSI bus parity error.
D5	02	Message Reject received on a valid message.
D7	00	Source driver programming error.
E0	03	Fault Manager detected an unknown error code.
E0	06	Maximum number of errors for this I/O exceeded.
E0	07	Drive reported recovered error without transferring all data.

Instance Codes

An instance code is a number that uniquely identifies an event being reported.

Instance Code Structure

Figure 7-1 shows the structure of an instance code. By fully understanding its structure, each code can be translated without using the FMU.

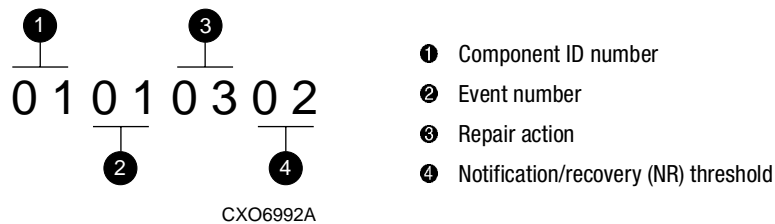

Figure 7-1. Structure of an instance code

Instance Codes and FMU

The format of an Instance Code as it appears in Sense Data Responses is shown in Table 7-13.

Table 7-13 Instance Code Format									
offset	bit →	7	6	5	4	3	2	1	0
{8}	32	NR Threshold							
{9}	33	Repair Action							
{10}	34	Event Number							
{11}	35	Component ID							

NOTE: The offset values enclosed in braces ({ }) apply only to the passthrough device reset event sense data response format (see Table 7-1).

The nonbraced offset values apply only to the logical device event sense data response formats shown in the templates that begin on page 7-17.

Notification/Recovery (NR) Threshold

Located at byte offset {8}32 is the NR threshold assigned to the event. This value is used during Symptom-Directed Diagnosis procedures to determine when to take notification/recovery action. For a description of event notification/recovery threshold classifications, see Table 7–14.

Table 7–14 Event Notification/Recovery Threshold Classifications

Threshold Value	Classification	Description
01	IMMEDIATE	Failure or potential failure of a component critical to proper controller operation is indicated; immediate attention is required.
02	HARD	Failure of a component that affects controller performance or precludes access to a device connected to the controller is indicated.
0A	SOFT	An unexpected condition detected by a controller software component (e.g., protocol violations, host buffer access errors, internal inconsistencies, uninterpreted device errors, etc.) or an intentional restart or shutdown of controller operation is indicated.
64	INFORMATIONAL	An event having little or no effect on proper controller or device operation is indicated.

Repair Action

The Repair Action found at byte offset {9}33 indicates the *recommended repair action code* assigned to the event. This value is used during Symptom-Directed Diagnosis procedures to determine what notification/recovery (recommended repair) action to take upon reaching the NR Threshold. For details about recommended repair action codes, see the “Recommended Repair Action Codes” section on page 7–88.

Event Number

The Event Number is located at byte offset {10}34. Combining this number with the Component ID field value uniquely-identifies the reported event.

Component ID

A component ID is located at byte offset {11}35. This number uniquely identifies the software component that detected the event. For details about components ID numbers, see the “Component Identifier Codes” on page 7-93.

Table 7-15 contains the numerous instance codes, *in ascending order*, that might be issued by the controller fault management software.

Table 7-15 Instance Codes (Sheet 1 of 24)

Instance Code	Description	Template	Repair Action Code
01010302	An unrecoverable hardware detected fault occurred.	01	03
0102030A	An unrecoverable software inconsistency was detected or an intentional restart or shutdown of controller operation was requested.	01	03
01032002	Nonvolatile parameter memory component EDC check failed; content of the component reset to default settings.	11	20
02020064	Disk Bad Block Replacement attempt completed for a write within the user data area of the disk. Note that due to the way Bad Block Replacement is performed on SCSI disk drives, information on the actual replacement blocks is not available to the controller and is therefore not included in the event report.	51	00
02032001	Journal SRAM backup battery failure; detected during <i>system restart</i> . The Memory Address field contains the starting physical address of the Journal SRAM.	12	20
02042001	Applies to: <i>periodic check</i> .		
02052301	A processor interrupt was generated by the CACHEA0 Memory Controller with an indication that the CACHE backup battery has failed or is low (needs charging). The Memory Address field contains the starting physical address of the CACHEA0 memory.	12	23
02072201	The CACHEA0 Memory Controller failed testing performed by the Cache Diagnostics. The Memory Address field contains the starting physical address of the CACHEA0 memory.	14	22
02082201	Applies to: <i>CACHEA1</i> .		
02090064	A data compare error was detected during the execution of a compare modified READ or WRITE command.	51	00

Table 7–15 Instance Codes (Sheet 2 of 24)

Instance Code	Description	Template	Repair Action Code
020B2201	Failed read test of a write-back metadata page residing in cache. Dirty write-back cached data exists and cannot be flushed to media. The dirty data is lost. The Memory Address field contains the starting physical address of the CACHEA0 memory.	14	22
020C2201	Cache Diagnostics have declared the cache bad during testing. The Memory Address field contains the starting physical address of the CACHEA0 memory.	14	22
020D2401	The wrong write cache module is configured. The serial numbers do not match. Either the existing or the expected cache contains dirty write-back cached data. Note that in this instance, the Memory Address, Byte Count, FX Chip Register, Memory Controller register, and Diagnostic register fields are undefined.	14	24
020E2401	The write cache module is missing. A cache is expected to be configured and contains dirty write-back cached data. Note that in this instance, the Memory Address, Byte Count, FX Chip Register, Memory Controller register, and Diagnostic register fields are undefined.	14	24
02102401	The write cache modules are not configured properly for a dual-redundant configuration. One of the cache modules is not the same size to perform cache failover of dirty write-back cached data. Note that in this instance, the Memory Address, Byte Count, FX Chip Register, Memory Controller register, and Diagnostic register fields are undefined.	14	24
02110064	Disk Bad Block Replacement attempt completed for a read within the user data area of the disk. Note that due to the way Bad Block Replacement is performed on SCSI disk drives, information on the actual replacement blocks is not available to the controller and is therefore not included in the event report.	51	00
021A0064	Disk Bad Block Replacement attempt completed for a write of controller metadata to a location outside the user data area of the disk. Note that due to the way Bad Block Replacement is performed on SCSI disk drives, information on the actual replacement blocks is not available to the controller and is therefore not included in the event report.	41	00

Table 7-15 Instance Codes (Sheet 3 of 24)

Instance Code	Description	Template	Repair Action Code
021B0064	Disk Bad Block Replacement attempt completed for a read of controller metadata from a location outside the user data area of the disk. Note that due to the way Bad Block Replacement is performed on SCSI disk drives, information on the actual replacement blocks is not available to the controller and is therefore not included in the event report.	41	00
021D0064	Unable to lock the other controller's cache in a write-cache failover attempt. Either a latent error could not be cleared on the cache or the other controller did not release its cache. Note that in this instance, the Memory Address, Byte Count, FX Chip register, Memory Controller register, and Diagnostic register fields are undefined.	14	00
021E0064	The device specified in the Device Locator field has been added to the RAIDset associated with the logical unit. The RAIDset is now in Reconstructing state.	51	00
02280064	The device specified in the Device Locator field has been added to the Mirrorset associated with the logical unit. The new Mirrorset member is now in Copying state.	51	00
022C0064	The device specified in the Device Locator has transitioned from Copying or Normalizing state to Normal state.	51	00
022E0064	The device specified in the Device Locator field has been converted to a Mirrorset associated with the logical unit.	51	00
022F0064	The mirrored device specified in the Device Locator field has been converted to a single device associated with the logical unit.	51	00
02383A01	The CACHEB0 Memory Controller, which resides on the other cache module failed testing performed by the Cache Diagnostics. This is the mirrored cache Memory Controller. The Memory Address field contains the starting physical address of the CACHEB0 memory.	14	3A
02392201	Both the CACHEB0 Memory Controller and CACHEB1 Memory Controller, which resides on the other cache module, failed testing performed by the Cache Diagnostics. Data cannot be accessed in the primary cache or the mirror cache. The Memory Address field contains the starting physical address of the CACHEA0 memory.	14	22

Table 7–15 Instance Codes (Sheet 4 of 24)

Instance Code	Description	Template	Repair Action Code
023E2401	Metadata residing in the controller and on the two cache modules disagree as to the mirror node. Note that in this instance, the Memory Address, Byte Count, FX Chip register, Memory Controller register, and Diagnostic register fields are undefined.	14	24
023F2301	The cache backup battery covering the mirror cache is insufficiently charged. The Memory Address field contains the starting physical address of the CACHEB1 memory.	12	23
02402301	The cache backup battery covering the mirror cache has been declared bad. Either it failed testing performed by the Cache Diagnostics during system startup or it was low (insufficiently charged) for longer than the expected duration. The Memory Address field contains the starting physical address of the CACHEB1 memory.	12	23
02412401	Mirrored cache writes have been disabled. Either the primary or the mirror cache has been declared bad or data invalid and will not be used. Note that in this instance, the Memory Address, Byte Count, FX Chip register, Memory Controller register, and Diagnostic register fields are undefined.	14	24
02422464	Cache failover attempt failed because the other cache was illegally configured with DIMMs. Note that in this instance, the Memory Address, Byte Count, FX Chip register, Memory Controller register, and Diagnostic register fields are undefined.	14	24
02492401	The write cache module which is the mirror for the primary cache is unexpectedly not present (missing). A cache is expected to be configured and it may contain dirty write cached data. Note that in this instance, the Memory Address, Byte Count, FX Chip register, Memory Controller register, and Diagnostic register fields are undefined.	14	24
024A2401	Mirroring is enabled and the primary write cache module is expectedly not present (missing). A cache is expected to be configured and it may contain dirty write cached data. Note that in this instance, the Memory Address, Byte Count, FX Chip register, Memory Controller register, and Diagnostic register fields are undefined.	14	24

Table 7-15 Instance Codes (Sheet 5 of 24)

Instance Code	Description	Template	Repair Action Code
024B2401	Write-back caching has been disabled either due to a cache or battery-related problem. The exact nature of the problem is reported by other instance codes. Note that in this instance, the Memory Address, Byte Count, FX Chip register, Memory Controller register, and Diagnostic register fields are undefined.	14	24
024F2401	This cache module is populated with DIMMs incorrectly. Cache metadata resident in the cache module indicates that unflushed write cache data exists for a cache size different than what is found present. Note that in this instance, the Memory Address, Byte Count, FX Chip register, Memory Controller register, and Diagnostic register fields are undefined.	14	24
0251000A	This command failed because the target unit is not online to the controller. The Information field of the Device Sense Data contains the block number of the first block in error.	51	00
0253000A	The data supplied from the host for a data compare operation differs from the data on the disk in the specified block. The Information field of the Device Sense Data contains the block number of the first block in error.	51	00
0254000A	The command failed due to a host data transfer failure. The Information field of the Device Sense Data contains the block number of the first block in error.	51	00
0255000A	The controller was unable to successfully transfer data to target unit. The Information field of the Device Sense Data contains the block number of the first block in error.	51	00
0256000A	The write operation failed because the unit is Data Safety Write Protected. The Information field of the Device Sense Data contains the block number of the first block in error.	51	00
0257000A	An attempt to reassign a bad disk block failed. The contents of the disk block is lost. The Information field of the Device Sense Data contains the block number of the first block in error.	51	00
0258000A	This command was aborted prior to completion. The Information field of the Device Sense Data contains the block number of the first block in error.	51	00
0259000A	The write operation failed because the unit is hardware write protected. The Information field of the Device Sense Data contains the block number of the first block in error.	51	00

Table 7–15 Instance Codes (Sheet 6 of 24)

Instance Code	Description	Template	Repair Action Code
025A000A	The command failed because the unit became inoperative prior to command completion. The Information field of the Device Sense Data contains the block number of the first block in error.	51	00
025B000A	The command failed because the unit became unknown to the controller prior to command completion. The Information field of the Device Sense Data contains the block number of the first block in error.	51	00
025C000A	The command failed because of a unit media format error. The Information field of the Device Sense Data contains the block number of the first block in error.	51	00
025D000A	The command failed for an unknown reason. The Information field of the Device Sense Data contains the block number of the first block in error.	51	00
025F2201	Memory diagnostics performed during controller initialization detected an excessive number (512 pages or more) of memory errors detected on the <i>primary cache memory</i> . Diagnostics have not declared the cache failed, due to the isolated bad memory regions, but this is a warning to replace the cache as soon as possible in case of further degradation. The software performed the necessary error recovery as appropriate. Note that in this instance, the Memory Address and Byte Count fields are undefined.	14	22
02603A01	Applies to <i>mirrored cache memory</i> .		3A
02613801	Memory diagnostics performed during controller initialization detected that the DIMM in <i>location 1</i> failed on the cache module. Note that in this instance, the Byte Count field is undefined.	14	38
02623801	Applies to <i>location 2</i> .		
02633801	Applies to <i>location 3</i> .		
02643801	Applies to <i>location 4</i> .		
02653C01	Memory diagnostics performed during controller initialization detected that the DIMM in <i>location 3</i> on the other controller's cache module (on mirrored cache) failed. Mirroring has been disabled. Note that in this instance, the Byte Count field is undefined.	14	3C
02663C01	Applies to <i>location 4</i> .		
02675201	The device specified in the Device Locator field has been removed from the RAIDset associated with the logical unit. The removed device is now in the Failedset. The RAIDset is now in Reduced state.	51	52

Table 7-15 Instance Codes (Sheet 7 of 24)

Instance Code	Description	Template	Repair Action Code
0268530A	The device specified in the Device Locator field failed to be added to the RAIDset associated with the logical unit. The device will remain in the Spareset.	51	53
02695401	The device specified in the Device Locator field failed to be added to the RAIDset associated with the logical unit. The failed device has been moved to the Failedset.	51	54
026A5001	The RAIDset associated with the logical unit has gone inoperative.	51	50
026B0064	The RAIDset associated with the logical unit has transitioned from <i>Normal state to Reconstructing state</i> .	51	00
026C0064	Applies to <i>Reconstructing state to Normal state</i> .		
026D5201	The device specified in the Device Locator field has been removed from the Mirrorset associated with the logical unit. The removed device is now in the Failedset.	51	52
026E0001	The device specified in the Device Locator field has been reduced from the Mirrorset associated with the logical unit. The nominal number of members in the mirrorset has been decreased by one. The reduced device is now available for use.	51	00
026F530A	The device specified in the Device Locator field failed to be added to the mirrorset associated with the logical unit. The device will remain in the Spareset.	51	53
02705401	The device specified in the Device Locator field failed to be added to the mirrorset associated with the logical unit. The failed device has been moved to the Failedset.	51	54
02710064	The mirrorset associated with the logical unit has had its nominal membership changed. The new nominal number of members for the mirrorset is specified in the Device Sense Data Information field.	51	00
02725101	The Mirrorset associated with the logical unit has gone inoperative.	51	51
02730001	The device specified in the Device Locator field had a read error which has been repaired with data from another mirrorset member.	51	00
02745A0A	The device specified in the Device Locator field had a read error. Attempts to repair the error with data from another mirrorset member failed due to lack of alternate error-free data source.	51	5A

Table 7–15 Instance Codes (Sheet 8 of 24)

Instance Code	Description	Template	Repair Action Code
02755601	The device specified in the Device Locator field had a read error. Attempts to repair the error with data from another mirrorset member failed due to a write error on the original device. The original device will be removed from the mirrorset.	51	56
02773D01	The mirrored cache is not being used because the data in the mirrored cache is inconsistent with the data in the primary cache. The primary cache contains valid data, so the controller is caching solely from the primary cache. The mirrored cache is declared “failed”, but this is not due to a hardware fault, only inconsistent data. Mirrored writes have been disabled until this condition is cleared. Note that in this instance, the Memory Address, Byte Count, FX Chip register, Memory Controller register, and Diagnostic register fields are undefined.	14	3D
02782301	The cache backup battery is not present. The Memory Address field contains the starting physical address of the CACHEA0 memory.	12	23
02792301	The cache backup battery covering the mirror cache is not present. The Memory Address field contains the starting physical address of the CACHEB1 memory.	12	23
027A2201	The <i>CACHEB0</i> Memory Controller failed Cache Diagnostics testing performed on the other cache during a cache failover attempt. The Memory Address field contains the starting physical address of the <i>CACHEB0</i> memory.	14	22
027B2201	Applies to <i>CACHEB1</i> .		
027C2201	The <i>CACHEB0</i> and <i>CACHEB1</i> Memory Controllers failed Cache Diagnostics testing performed on the other cache during a cache failover attempt. The Memory Address field contains the starting physical address of the <i>CACHEB0</i> memory.	14	22
027D5B01	The Mirrorset associated with the logical unit has gone inoperative due to a disaster tolerance failsafe locked condition.	51	5B
027F2301	The CACHE backup battery has been declared bad. The battery did not become fully charged within the expected duration. The Memory Address field contains the starting physical address of the CACHEA0 memory.	12	23
02825C64	The Mirrorset associated with the logical unit has just had a membership change such that disaster tolerance failsafe error mode can now be enabled if desired.	51	5C

Table 7-15 Instance Codes (Sheet 9 of 24)

Instance Code	Description	Template	Repair Action Code
02864002	The controller has set the specified unit Data Safety Write Protected due to an unrecoverable device failure which prevents writing cached data.	51	40
02872301	The CACHE backup battery has exceeded the maximum number of deep discharges. Battery capacity may be below specified values. The Memory Address field contains the starting physical address of the CACHEA0 memory.	12	23
02882301	The CACHE backup battery covering the mirror cache has exceeded the maximum number of deep discharges. Battery capacity may be below specified values. The Memory Address field contains the starting physical address of the CACHEB1 memory.	12	23
02892301	The CACHE backup battery is near its end of life. The Memory Address field contains the starting physical address of the CACHEA0 memory.	12	23
028A2301	The CACHE backup battery covering the mirror cache is near its end of life. The Memory Address field contains the starting physical address of the CACHEB1 memory.	12	23
028B3801	Memory diagnostics performed during controller initialization detected that the DIMM in <i>location 1</i> failed on the cache module. The failed DIMM should be replaced as soon as possible. Control Structures have been moved to secondary memory and are now unprotected against additional memory failures. Note that in this instance, the Byte Count field is undefined.	14	38
028C3801	Applies to <i>location 2</i> .		
028D0064	The device specified in the Device Locator field has been removed from the SPARESET into the FAILEDSET. The new nominal number of members for the SPARESET is specified in the Device Sense Data Information field.	51	00
028F8901 02908901 02918901	The host command failed because the remote copy set went failsafe locked prior to command completion. The remote copy set is specified by the Remote Copy Name field. The Information field of the Device Sense Data contains the block number of the first block in error.	51	89
02925D01	The device specified in the Device Locator field has been removed from the SPARESET into the FAILEDSET; there are no devices left in the SPARESET. The new nominal number of members for the SPARESET is specified in the Device Sense Data Information field.	51	5D

Table 7-15 Instance Codes (Sheet 10 of 24)

Instance Code	Description	Template	Repair Action Code
02931101	The Uninterruptable Power Supply (UPS) signaled a 2 minute warning (TMW) before it signaled AC line failure. UPS signals will be ignored until this condition clears.	12	11
0294000A	A requested block of data contains a forced error. A forced error occurs when a disk block is successfully reassigned, but the data in that block is lost. Re-writing the disk block will clear the forced error condition. The Information field of the Device Sense Data contains the block number of the first block in error.	51	00
0295000A	The snapshot unit indicated by the Unit Number field has been disabled. Reads to the unit will fail. Reasons for disabling the snapshot are a failure to copy to the temporary storageset, or no room on the temporary storageset to properly fail over the snapshot.	51	00
03010101	No command control structures available for disk operation. Note that in this instance, the Associated Additional Sense Code and Associated Additional Sense Code Qualifier fields are undefined.	41	01
03022002	SCSI interface chip command timeout during disk operation. Note that in this instance, the Associated Additional Sense Code and Associated Additional Sense Code Qualifier fields are undefined.	41	20
03034002	Byte transfer timeout during disk operation. Note that in this instance, the Associated Additional Sense Code and Associated Additional Sense Code Qualifier fields are undefined.	41	40
03044402	SCSI bus errors during disk operation. Note that in this instance, the Associated Additional Sense Code and Associated Additional Sense Code Qualifier fields are undefined.	41	44
03052002	Device port SCSI chip reported gross error during disk operation. Note that in this instance, the Associated Additional Sense Code and Associated Additional Sense Code Qualifier fields are undefined.	41	20
03062002	Non-SCSI bus parity error during disk operation. Note that in this instance, the Associated Additional Sense Code and Associated Additional Sense Code Qualifier fields are undefined.	41	20
03070101	Source driver programming error encountered during disk operation. Note that in this instance, the Associated Additional Sense Code and Associated Additional Sense Code Qualifier fields are undefined.	41	01

Table 7-15 Instance Codes (Sheet 11 of 24)

Instance Code	Description	Template	Repair Action Code
03080101	Miscellaneous SCSI Port Driver coding error detected during disk operation. Note that in this instance, the Associated Additional Sense Code and Associated Additional Sense Code Qualifier fields are undefined.	41	01
03094002	An unrecoverable disk drive error was encountered while performing work related to disk unit operations.	51	40
030C4002	A Drive failed because a Test Unit Ready command or a Read Capacity command failed.	51	40
030D000A	Drive was failed by a Mode Select command received from the host.	51	00
030E4002	Drive failed due to a deferred error reported by drive.	51	40
030F4002	Unrecovered Read or Write error.	51	40
03104002	No response from one or more drives.	51	40
0311430A	Nonvolatile memory and drive metadata indicate conflicting drive configurations.	51	43
0312430A	The Synchronous Transfer Value differs between drives in the same storageset.	51	43
03134002	Maximum number of errors for this data transfer operation exceeded.	51	40
03144002	Drive reported recovered error without transferring all data.	51	40
03154002	Data returned from drive is invalid.	51	40
03164002	Request Sense command to drive failed.	51	40
03170064	Illegal command for pass through mode.	51	00
03180064	Data transfer request error.	51	00
03194002	Premature completion of a drive command.	51	40
031A4002	Command timeout.	51	40
031B0101	Watchdog timer timeout.	51	01
031C4002	Disconnect timeout.	51	40
031D4002	Unexpected bus phase.	51	40
031E4002	Disconnect expected.	51	40
031F4002	ID Message not sent by drive.	51	40
03204002	Synchronous negotiation error.	51	40
03214002	The drive unexpectedly disconnected from the SCSI bus.	51	40

Table 7-15 Instance Codes (Sheet 12 of 24)

Instance Code	Description	Template	Repair Action Code
03224002	Unexpected message.	51	40
03234002	Unexpected Tag message.	51	40
03244002	Channel busy.	51	40
03254002	Message Reject received on a valid message.	51	40
0326450A	The disk device reported Vendor Unique SCSI Sense Data.	51	45
03270101	A disk related error code was reported which was unknown to the Fault Management software. Note that in this instance, the Associated Additional Sense Code and Associated Additional Sense Code Qualifier fields are undefined.	41	01
0328450A	The disk device reported standard SCSI Sense Data.	51	45
03324002	SCSI bus selection timeout.	Passthrough	40
03330002	Device power on reset.	Passthrough	00
03344002	Target assertion of REQ after WAIT DISCONNECT.	Passthrough	40
03354002	During device initialization a Test Unit Ready command or a Read Capacity command to the device failed.	Passthrough	40
03364002	During device initialization the device reported a deferred error.	Passthrough	40
03374002	During device initialization the maximum number of errors for a data transfer operation was exceeded.	Passthrough	40
03384002	Request Sense command to the device failed.	Passthrough	40
03394002	Command timeout.	Passthrough	40
033A4002	Disconnect timeout.	Passthrough	40
033B4002	Unexpected bus phase.	Passthrough	40
033C4002	The device unexpectedly disconnected from the SCSI bus.	Passthrough	40
033D4002	Unexpected message.	Passthrough	40
033E4002	Message Reject received on a valid message.	Passthrough	40
033F0101	No command control structures available for passthrough device operation.	Passthrough	01
03402002	Device port SCSI chip reported gross error.	Passthrough	20
03410101	Miscellaneous SCSI Port Driver coding error.	Passthrough	01
03420101	A passthrough device related internal error code was reported which is not recognized by the Fault Management software.	Passthrough	01

Table 7-15 Instance Codes (Sheet 13 of 24)

Instance Code	Description	Template	Repair Action Code
03434002	During device initialization the device reported unexpected standard SCSI Sense Data.	Passthrough	40
03BE0701	The EMU for the cabinet indicated by the Associated Port field has powered down the cabinet because there are less than four working power supplies present. Note that in this instance, the Associated Target, Associated Additional Sense Code, and Associated Additional Sense Code Qualifier fields are undefined.	41	07
03BF0D01	The EMU for the cabinet indicated by the Associated Port field has powered down the cab because the temperature has reached its allowable maximum. Note that in this instance, the Associated Target, Associated Additional Sense Code, and Associated Additional Sense Code Qualifier fields are undefined.	41	0D
03C00601	The EMU for the cabinet indicated by the Associated Port field has powered down the cabinet because a fan has been missing for more than 8 minutes. Note that in this instance, the Associated Target, Associated Additional Sense Code, and Associated Additional Sense Code Qualifier fields are undefined.	41	06
03C10F64	The EMU for the cabinet indicated by the Associated Port field has allowed the cab to receive power because the number of power supplies is greater or equal to four. Note that in this instance, the Associated Target, Associated Additional Sense Code, and Associated Additional Sense Code Qualifier fields are undefined.	41	0F
03C20F64	The EMU for the cabinet indicated by the Associated Port field has allowed the cab to receive power because the high temperature problem has been fixed. Note that in this instance, the Associated Target, Associated Additional Sense Code, and Associated Additional Sense Code Qualifier fields are undefined.	41	0F
03C30F64	The EMU for the cabinet indicated by the Associated Port field has allowed the cab to receive power because the fan that was missing has been replaced. Note that in this instance, the Associated Target, Associated Additional Sense Code, and Associated Additional Sense Code Qualifier fields are undefined.	41	0F

Table 7–15 Instance Codes (Sheet 14 of 24)

Instance Code	Description	Template	Repair Action Code
03C80101	No command control structures available for operation to a device which is unknown to the controller. Note that in this instance, the Associated Additional Sense Code and Associated Additional Sense Code Qualifier fields are undefined.	41	01
03C92002	SCSI interface chip command timeout during operation to a device which is unknown to the controller. Note that in this instance, the Associated Additional Sense Code and Associated Additional Sense Code Qualifier fields are undefined.	41	20
03CA4002	Byte transfer timeout during operation to a device which is unknown to the controller. Note that in this instance, the Associated Additional Sense Code and Associated Additional Sense Code Qualifier fields are undefined.	41	40
03CB0101	Miscellaneous SCSI Port Driver coding error detected during operation to a device which is unknown to the controller. Note that in this instance, the Associated Additional Sense Code and Associated Additional Sense Code Qualifier fields are undefined.	41	01
03CC0101	An error code was reported which was unknown to the Fault Management software. Note that in this instance, the Associated Additional Sense Code and Associated Additional Sense Code Qualifier fields are undefined.	41	01
03CD2002	Device port SCSI chip reported gross error during operation to a device which is unknown to the controller. Note that in this instance, the Associated Additional Sense Code and Associated Additional Sense Code Qualifier fields are undefined.	41	20
03CE2002	Non-SCSI bus parity error during operation to a device which is unknown to the controller. Note that in this instance, the Associated Additional Sense Code and Associated Additional Sense Code Qualifier fields are undefined.	41	20
03CF0101	Source driver programming error encountered during operation to a device which is unknown to the controller. Note that in this instance, the Associated Additional Sense Code and Associated Additional Sense Code Qualifier fields are undefined.	41	01
03D04002	A failure occurred while attempting a SCSI Test Unit Ready or Read Capacity command to a device. The device type is unknown to the controller. Note that in this instance, the Associated Additional Sense Code and Associated Additional Sense Code Qualifier fields are undefined.	41	40

Table 7-15 Instance Codes (Sheet 15 of 24)

Instance Code	Description	Template	Repair Action Code
03D14002	The identification of a device does not match the configuration information. The actual device type is unknown to the controller. Note that in this instance, the Associated Additional Sense Code, and Associated Additional Sense Code Qualifier fields are undefined.	41	40
03D24402	SCSI bus errors during device operation. The device type is unknown to the controller. Note that in this instance, the Associated Additional Sense Code and Associated Additional Sense Code Qualifier fields are undefined.	41	44
03D3450A	During device initialization, the device reported the SCSI Sense Key NO SENSE. This indicates that there is no specific sense key information to be reported for the designated logical unit. This would be the case for a successful command or a command that received CHECK CONDITION or COMMAND TERMINATED status because one of the FM, EOM, or ILI bits is set to one in the sense data flags field.	41	45
03D4450A	During device initialization, the device reported the SCSI Sense Key RECOVERED ERROR. This indicates the last command completed successfully with some recovery action performed by the target.	41	45
03D5450A	During device initialization, the device reported the SCSI Sense Key NOT READY. This indicates that the logical unit addressed cannot be accessed. Operator intervention may be required to correct this condition.	41	45
03D6450A	During device initialization, the device reported the SCSI Sense Key MEDIUM ERROR. This indicates that the command terminated with a non-recovered error condition that was probably caused by a flaw in the medium or an error in the recorded data. This sense key may also be returned if the target is unable to distinguish between a flaw in the medium and a specific hardware failure (HARDWARE ERROR sense key).	41	45
03D7450A	During device initialization, the device reported the SCSI Sense Key HARDWARE ERROR. This indicates that the target detected a non-recoverable hardware failure (for example, controller failure, device failure, parity error, etc.) while performing the command or during a self test.	41	45

Table 7–15 Instance Codes (Sheet 16 of 24)

Instance Code	Description	Template	Repair Action Code
03D8450A	During device initialization, the device reported the SCSI Sense Key ILLEGAL REQUEST. Indicates that there was an illegal parameter in the command descriptor block or in the additional parameters supplied as data for some commands (FORMAT UNIT, SEARCH DATA, etc.). If the target detects an invalid parameter in the command descriptor block, then it shall terminate the command without altering the medium. If the target detects an invalid parameter in the additional parameters supplied as data, then the target may have already altered the medium. This sense key may also indicate that an invalid IDENTIFY message was received.	41	45
03D9450A	During device initialization, the device reported the SCSI Sense Key UNIT ATTENTION. This indicates that the removable medium may have been changed or the target has been reset.	41	45
03DA450A	During device initialization, the device reported the SCSI Sense Key DATA PROTECT. This indicates that a command that reads or writes the medium was attempted on a block that is protected from this operation. The read or write operation is not performed.	41	45
03DB450A	During device initialization, the device reported the SCSI Sense Key BLANK CHECK. This indicates that a write-once device encountered blank medium or format-defined end-of-data indication while reading or a write-once device encountered a non-blank medium while writing.	41	45
03DC450A	During device initialization, the device reported a SCSI Vendor Specific Sense Key. This sense key is available for reporting vendor specific conditions.	41	45
03DD450A	During device initialization, the device reported the SCSI Sense Key COPY ABORTED. This indicates a COPY, COMPARE, or COPY AND VERIFY command was aborted due to an error condition on the source device, the destination device, or both.	41	45
03DE450A	During device initialization, the device reported the SCSI Sense Key ABORTED COMMAND. This indicates the target aborted the command. The initiator may be able to recover by trying the command again.	41	45
03DF450A	During device initialization, the device reported the SCSI Sense Key EQUAL. This indicates a SEARCH DATA command has satisfied an equal comparison.	41	45

Table 7-15 Instance Codes (Sheet 17 of 24)

Instance Code	Description	Template	Repair Action Code
03E0450A	During device initialization, the device reported the SCSI Sense Key VOLUME OVERFLOW. This indicates a buffered peripheral device has reached the end-of-partition and data may remain in the buffer that has not been written to the medium. A RECOVER BUFFERED DATA command(s) may be issued to read the unwritten data from the buffer.	41	45
03E1450A	During device initialization, the device reported the SCSI Sense Key MISCMPARE. This indicates the source data did not match the data read from the medium.	41	45
03E2450A	During device initialization, the device reported a reserved SCSI Sense Key.	41	45
03E40F64	The EMU has indicated that Termination Power is good on all ports. Note that in this instance, the Associated Target, Associated Additional Sense Code, and Associated Additional Sense Code Qualifier fields are undefined.	41	0F
03E58002	The EMU has detected bad Termination Power on the indicated port. Note that in this instance, the Associated Target, Associated Additional Sense Code, and Associated Additional Sense Code Qualifier fields are undefined.	41	80
03EE0064	The EMU for the cabinet indicated by the Associated Port field has become <i>available</i> . Note that in this instance, the Associated Target, Associated Additional Sense Code, and the Associated Additional Sense Code Qualifier fields are undefined.	41	00
03EF8301	Applies to <i>unavailable</i> .		83
03F10502	The SWAP interrupt from the device port indicated by the Associated Port field can not be cleared. All SWAP interrupts from all ports will be disabled until corrective action is taken. When SWAP interrupts are disabled, both controller front panel button presses and removal/insertion of devices are not detected by the controller. Note that in this instance, the Associated Target, Associated Additional Sense Code, and Associated Additional Sense Code Qualifier fields are undefined.	41	05

Table 7–15 Instance Codes (Sheet 18 of 24)

Instance Code	Description	Template	Repair Action Code
03F20064	The SWAP interrupts have been cleared and re-enabled for all device ports. Note that in this instance, the Associated Port, Associated Target, Associated Additional Sense Code, and Associated Additional Sense Code Qualifier fields are undefined.	41	00
03F30064	An asynchronous SWAP interrupt was detected by the controller for the device port indicated by the Associated Port field. Possible reasons for this occurrence include: <ul style="list-style-type: none"> ■ device insertion or removal ■ shelf power failure ■ SWAP interrupts reenabled Note that in this instance, the Associated Target, Associated Additional Sense Code, and Associated Additional Sense Code Qualifier fields are undefined.	41	00
03F40064	Device services had to reset the port to clear a bad condition. Note that in this instance, the Associated Target, Associated Additional Sense Code, and Associated Additional Sense Code Qualifier fields are undefined.	41	00
03F60402	The controller shelf is reporting a problem. This could mean one or both of the following: <ul style="list-style-type: none"> ■ If the shelf is using dual power supplies, one power supply has failed. ■ One of the shelf cooling fans has failed. Note that in this instance, the Associated Target, Associated Additional Sense Code, and Associated Additional Sense Code Qualifier fields are undefined.	41	04
03F70401	The shelf indicated by the Associated Port field is reporting a problem. This could mean one or both of the following: <ul style="list-style-type: none"> ■ If the shelf is using dual power supplies, one power supply has failed. ■ One of the shelf cooling fans has failed. Note that in this instance, the Associated Target, Associated Additional Sense Code, and Associated Additional Sense Code Qualifier fields are undefined.	41	04

Table 7-15 Instance Codes (Sheet 19 of 24)

Instance Code	Description	Template	Repair Action Code
03F80701	The EMU has detected one or more bad power supplies. Note that in this instance, the Associated Target, Associated Additional Sense Code, and Associated Additional Sense Code Qualifier fields are undefined.	41	07
03F90601	The EMU has detected one or more bad fans. Note that in this instance, the Associated Target, Associated Additional Sense Code, and Associated Additional Sense Code Qualifier fields are undefined.	41	06
03FA0D01	The EMU has detected an elevated temperature condition. Note that in this instance, the Associated Target, Associated Additional Sense Code, and Associated Additional Sense Code Qualifier fields are undefined.	41	0D
03FB0E01	The EMU has detected an external air sense fault. Note that in this instance, the Associated Target, Associated Additional Sense Code, and Associated Additional Sense Code Qualifier fields are undefined.	41	0E
03FC0F01	The EMU-detected power supply fault is now fixed. Note that in this instance, the Associated Target, Associated Additional Sense Code, and Associated Additional Sense Code Qualifier fields are undefined.	41	0F
03FD0F01	The EMU-detected bad-fan fault is now fixed. Note that in this instance, the Associated Target, Associated Additional Sense Code, and Associated Additional Sense Code Qualifier fields are undefined.	41	0F
03FE0F01	The EMU-detected elevated temperature fault is now fixed. Note that in this instance, the Associated Target, Associated Additional Sense Code, and Associated Additional Sense Code Qualifier fields are undefined.	41	0F
03FF0F01	The EMU-detected external air sense fault is now fixed. Note that in this instance, the Associated Target, Associated Additional Sense Code, and Associated Additional Sense Code Qualifier fields are undefined.	41	0F
07030B0A	Failover Control detected a receive packet sequence number mismatch. The controllers are out of synchronization with each other and are unable to communicate. Note that in this instance, the Last Failure Code and Last Failure Parameters fields are undefined.	05	0B

Table 7-15 Instance Codes (Sheet 20 of 24)

Instance Code	Description	Template	Repair Action Code
07040B0A	Failover Control detected a transmit packet sequence number mismatch. The controllers are out of synchronization with each other and are unable to communicate. Note that in this instance, the Last Failure Code and Last Failure Parameters fields are undefined.	05	0B
07050064	Failover Control received a Last Gasp message from the other controller. The other controller is expected to restart itself within a given time period. If it does not, it will be held reset with the "Kill" line.	05	00
07060C01	Failover Control detected that both controllers are acting as <i>SCSI ID 6</i> . Since ids are determined by hardware, it is unknown which controller is the real <i>SCSI ID 6</i> . Note that in this instance, the Last Failure Code and Last Failure Parameters fields are undefined.	05	0C
07070C01	Applies to <i>SCSI ID 7</i> .		
07080B0A	Failover Control was unable to send keepalive communication to the other controller. It is assumed that the other controller is hung or not started. Note that in this instance, the Last Failure Code and Last Failure Parameters fields are undefined.	05	0B
07090064	Failover Control received a Code Load message from the other controller indicating that a new program image is being written onto its PCMCIA card. During this process, "keepalive" communication between controllers will not occur. This controller will not "kill" the other controller for lack of "keepalive" communication.	05	00
0C00370A	Memory System Error Analysis is indicated in the information preserved during a previous last failure but no error conditions are indicated in the available Memory Controller registers. The Quadrant 0 Memory Controller (CACHEA0) registers content is supplied.	14	37
0C103E02	The Quadrant 0 Memory Controller (CACHEA0) detected an Address Parity error.	14	3E
0C113E02	The Quadrant 1 Memory Controller (CACHEA1) detected an Address Parity error.	14	3E
0C123E02	The Quadrant 2 Memory Controller (CACHEB0) detected an Address Parity error.	14	3E
0C133E02	The Quadrant 3 Memory Controller (CACHEB1) detected an Address Parity error.	14	3E

Table 7-15 Instance Codes (Sheet 21 of 24)

Instance Code	Description	Template	Repair Action Code
0C203E02	The Quadrant 0 Memory Controller (CACHEA0) detected a Data Parity error.	14	3E
0C213E02	The Quadrant 1 Memory Controller (CACHEA1) detected a Data Parity error.	14	3E
0C223E02	The Quadrant 2 Memory Controller (CACHEB0) detected a Data Parity error.	14	3E
0C233E02	The Quadrant 3 Memory Controller (CACHEB1) detected a Data Parity error.	14	3E
0C303F02	The Quadrant 0 Memory Controller (CACHEA0) detected a Multibit ECC error.	14	3F
0C313F02	The Quadrant 1 Memory Controller (CACHEA1) detected a Multibit ECC error.	14	3F
0C323F02	The Quadrant 2 Memory Controller (CACHEB0) detected a Multibit ECC error.	14	3F
0C333F02	The Quadrant 3 Memory Controller (CACHEB1) detected a Multibit ECC error.	14	3F
0C403E02	The Quadrant 0 Memory Controller (CACHEA0) detected a Firewall error.	14	3E
0C413E02	The Quadrant 1 Memory Controller (CACHEA1) detected a Firewall error.	14	3E
0C423E02	The Quadrant 2 Memory Controller (CACHEB0) detected a Firewall error.	14	3E
0C433E02	The Quadrant 3 Memory Controller (CACHEB1) detected a Firewall error.	14	3E
0E010064	A remote copy set has been created specified by the Remote Copy Set Name field. The initiator unit of the Remote Copy Set is specified by the Initiator WWLID field.	90	00
0E020064	The remote copy set specified by the Remote Copy Set Name field has been deleted by the operator.	90	00
0E030064	The logical unit specified by the Target WWLID has transitioned from the normalizing or copying state to the normal state.	90	00
0E050064	The logical unit specified by the Target WWLID has been added to the remote copy set specified by the Remote Copy Set Name field. The new target member is now in the normalizing state.	90	00
0E068A01	The logical unit specified by the Target WWLID has been removed from the remote copy set specified by the Remote Copy Set Name field.	90	8A
0E078A01	The logical unit specified by the Target WWLID has been removed from the remote copy set specified by the Remote Copy Set Name field. The target was removed by the operator.	90	8A
0E088864	The remote copy set specified by the Remote Copy Set Name field has just had a membership change such that disaster tolerance failsafe error mode can now be enabled if desired.	90	88

Table 7-15 Instance Codes (Sheet 22 of 24)

Instance Code	Description	Template	Repair Action Code
0E098901	The remote copy set specified by the Remote Copy Set Name field has gone inoperative due to a disaster tolerance failsafe locked condition.	90	89
0E0A8D01	The unit is not made available to the host for the remote copy set specified in the Remote Copy Set Name field. This controller cannot verify a site failover did not occur; hence, it is not safe to present the WWLID.	90	8D
0E0B8E01	The unit is not made available to the host for the remote copy set specified in the Remote Copy Set Name field. This controller discovered a site failover occurred; hence, it cannot present the WWLID.	90	8E
0E0C8C01	The copy was terminated due to a <i>read failure on the initiator unit</i> . The initiator unit is specified by the Initiator WWLID field.	90	8C
0E0E8B01	Applies to <i>write failure on the target unit</i> .		8B
0E0F8B01	The copy was terminated due to a write failure on the target unit. The write failure was due to the links being down (target inaccessible). The copy will restart when at least one link is restored. The initiator unit is specified by the Initiator WWLID field.	90	8B
0E100064	A link (connection) to a target controller was just restored.	90	00
0E110064	The logical unit specified by the Target WWLID has transitioned from the merging state to the normal state.	90	00
0E120064	A link (connection) to a target controller was just restored.	90	00
0E1A8B01	Write history log merge has encountered a write error on the remote target unit.	90	8B
0E1D8B01	Write history log merge detected the target unit has failed.	90	8B
0E1E8C01	The asynchronous merge was terminated due to a read failure on the initiator unit.	90	8C
0E1F8B01	The asynchronous merge was terminated due to a write failure on the target unit.	90	8B
0E210064	The logical unit specified by the Target WWLID field has transitioned from the normal state to the write history logging state due to a remote connection event (the target controllers are no longer accessible) or CLI SUSPEND command.	90	00
0E220064	The logical unit specified by the Target WWLID field has transitioned from the logging state to the merging state due to a remote connection event (the target controllers are no longer accessible) or CLI RESUME command.	90	00

Table 7-15 Instance Codes (Sheet 23 of 24)

Instance Code	Description	Template	Repair Action Code
0E238F01	The logical unit specified by the Log Unit Number field has failed.	90	8F
0E258F01	Write history logging encountered a write error on the log unit.	90	8F
0E260064	There is no more space left at the end of the log unit for write history logging.	90	00
0E278F01	Write history log merge has encountered a read error on the log unit.	90	8F
0E288F01	The log unit has failed with a Media Format Error.	90	8F
0E290064	The log unit has been reset because the specified target member has been marked invalid. For instance, a site failover has been detected or a full member copy has started.	90	00
0E2A8F01	The logical unit specified by the Log Unit Number field is unknown or inoperative.	90	8F
0E2B0064	The log unit has been reset due to loss of cached data for the write history log. The specified target member has been marked for a full copy.	90	00
0E2C0064	A target member is being removed while write history logging is active.	90	00
43010064	Host Port Protocol component has detected that the other controller has failed and that this controller has taken over the units specified in the extended sense data.	04	00
43020064	Host Port Protocol component has detected that this controller has taken over (failed back) the units specified in the extended sense data.	04	00
82042002	A spurious interrupt was detected during the execution of a Subsystem Built-In Self Test.	13	20
82052002	An unrecoverable error was detected during execution of the HOST PORT Subsystem Test. The system will not be able to communicate with the host.	13	20
82062002	An unrecoverable error was detected during execution of the UART/DUART Subsystem Test. This will cause the console to be unusable. This will cause failover communications to fail.	13	20
82072002	An unrecoverable error was detected during execution of the FX Subsystem Test.	13	20
820A2002	An unrecoverable error was detected during execution of the PCI9060ES Test.	13	20

Table 7-15 Instance Codes (Sheet 24 of 24)

Instance Code	Description	Template	Repair Action Code
820B2002	An unrecoverable error was detected during execution of the Device Port Subsystem Built-In Self Test. One or more of the device ports on the controller module has failed; some/all of the attached storage is no longer accessible via this controller.	13	20

Last Failure Codes

A Last Failure Code is a number that uniquely describes an unrecoverable condition. It is found at byte offset 104 to 107 and only appears in two templates:

- Template 01—Last Failure Event Sense Data Response Format (see Table 7-1 on page 7-2)
- Template 05—Failover Event Sense Data Response Format (see Table 7-4 on page 7-5)

Last Failure Code Structure

Figure 7-2 shows the structure of a Last Failure Code. By fully understanding its structure, each code can be translated without using the FMU.

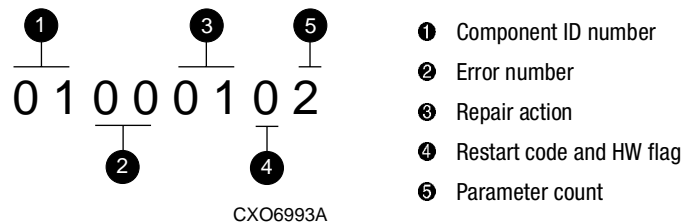

Figure 7-2. Structure of a last failure code

Last Failure Codes and FMU

The format of an Last Failure Code is shown in Table 7-16.

offset	bit →	7	6	5	4	3	2	1	0
104		HW	Restart Code			Parameter Count			
105		Repair Action							
106		Error Number							
107		Component ID							

NOTE: Do not confuse the Last Failure Code with that of an Instance Code (shown on page 7-20). They appear at different byte offsets and convey different information.

Hardware/Software (HW)

The HW flag is located at byte offset 104, bit 7. If this flag is a 1, the unrecoverable condition is due to a hardware-detected fault. If it is a 0, the unrecoverable condition is due to an inconsistency with the software, or an intentional restart or shutdown of the controller was requested.

Restart Code

Located at byte offset 104, bits 4-6, the Restart Code describes the actions taken to restart the controller after the unrecoverable condition was detected. See Table 7-17 for available restart codes.

Restart Code	Description
0	Full software restart
1	No restart
2	Automatic hardware restart

Parameter Count

The Parameter Count is located at byte offset 104, bits 0-3 and indicates the number of Last Failure Parameters containing supplemental information supplied.

Repair Action

The Repair Action code at byte offset 105 indicates the recommended repair action code assigned to the failure. This value is used during Symptom-Directed Diagnosis procedures to determine what notification/recovery action should be taken. For details about recommended repair action codes, see the “Recommended Repair Action Codes” section on page 7-88.

Error Number

The Error Number is located at byte offset 106. Combining this number with the Component ID field value uniquely-identifies the reported failure.

Component ID

The component ID is located at byte offset 107. This number uniquely-identifies the software component that detected the failure. For details about components ID numbers, see the “Component Identifier Codes” on page 7-93.

Table 7-18 contains the numerous last failure codes, *in ascending order*, that might be issued by the controller.

Table 7-18 Last Failure Codes (Sheet 1 of 41)

Code	Description	Repair Action Code
01000100	Memory allocation failure during executive initialization.	01
01010100	An interrupt without any handler was triggered.	01
01020100	Entry on timer queue was not of type AQ or BQ.	01
01030100	Memory allocation for a facility lock failed.	01
01040100	Memory initialization called with invalid memory type.	01
01082004	The core diagnostics reported a fault. <ul style="list-style-type: none"> ■ Last Failure Parameter[0] contains the error code value (same as blinking OCP LEDs error code). ■ Last Failure Parameter[1] contains the address of the fault. ■ Last Failure Parameter[2] contains the actual data value. ■ Last Failure Parameter[3] contains the expected data value. 	20

Table 7-18 Last Failure Codes (Sheet 2 of 41)

Code	Description	Repair Action Code
01090105	An NMI occurred during EXEC\$BUGCHECK processing. <ul style="list-style-type: none"> ■ Last Failure Parameter[0] contains the executive flags value. ■ Last Failure Parameter[1] contains the RIP from the NMI stack. ■ Last Failure Parameter[2] contains the read diagnostic register 0 value. ■ Last Failure Parameter[3] contains the FX Chip CSR value. ■ Last Failure Parameter[4] contains the SIP last failure code value 	01
010D0110	The System Information structure within the System Information Page has been reset to default settings. The only known cause for this event is an I960 processor hang caused by a reference to a memory region that is not implemented. When such a hang occurs, controller modules equipped with inactivity watchdog timer circuitry will spontaneously reboot after the watchdog timer expires (within seconds of the hang). Controller modules not so equipped will just hang as indicated by the green LED on the OCP remaining in a steady state.	01
010E0110	All structures contained in the System Information Page (SIP) and the Last Failure entries have been reset to their default settings. This is a normal occurrence for the first boot following manufacture of the controller module and during the transition from one software version to another if and only if the format of the SIP is different between the two versions. If this event is reported at any other time, follow the recommended repair action associated with this Last Failure code.	01
010F0110	All structures contained in the System Information Page and the Last Failure entries have been reset to their default settings as the result of certain controller manufacturing configuration activities. If this event is reported at any other time, follow the recommended repair action associated with this Last Failure code.	01
01100100	Non-maskable interrupt entered but no Non-maskable interrupt pending. This is typically caused by an indirect call to address 0.	01
01110106	A bugcheck occurred during EXEC\$BUGCHECK processing. <ul style="list-style-type: none"> ■ Last Failure Parameter [0] contains the executive flags value. ■ Last Failure Parameter [1] contains the RIP from the bugcheck call stack. ■ Last Failure Parameter [2] contains the first SIP last failure parameter value. ■ Last Failure Parameter [3] contains the second SIP last failure parameter value. ■ Last Failure Parameter [4] contains the SIP last failure code value. ■ Last Failure Parameter [5] contains the EXEC\$BUGCHECK call last failure code value. 	01

Table 7-18 Last Failure Codes (Sheet 3 of 41)

Code	Description	Repair Action Code
01140102	<p>DEBUG, ASSUME, or ASSUME_LE macro executed.</p> <ul style="list-style-type: none"> ■ Last Failure Parameter [0] contains the address of the module name where the macro is located. ■ Last Failure Parameter [1] contains the line number within the module where the macro is located. The high order byte of this value identifies the macro type: 0 = DEBUG, 1 = ASSUME, 2 = ASSUME_LE. 	01
01150106	<p>A bugcheck occurred before subsystem initialization completed.</p> <ul style="list-style-type: none"> ■ Last Failure Parameter [0] contains the executive flags value. ■ Last Failure Parameter [1] contains the RIP from the bugcheck call stack. ■ Last Failure Parameter [2] contains the first SIP last failure parameter value. ■ Last Failure Parameter [3] contains the second SIP last failure parameter value. ■ Last Failure Parameter [4] contains the SIP last failure code value. ■ Last Failure Parameter [5] contains the EXEC\$BUGCHECK call last failure code value. 	01
01170108	<p>The i960 reported a machine fault (parity error) while an NMI was being processed.</p> <ul style="list-style-type: none"> ■ Last Failure Parameter [0] contains the RESERVED value. ■ Last Failure Parameter [1] contains the access type value. ■ Last Failure Parameter [2] contains the access address value. ■ Last Failure Parameter [3] contains the number of faults value. ■ Last Failure Parameter [4] contains the PC value. ■ Last Failure Parameter [5] contains the AC value. ■ Last Failure Parameter [6] contains the fault type and subtype values. ■ Last Failure Parameter [7] contains the RIP value. 	01
01180105	<p>A machine fault (parity error) occurred during EXEC\$BUGCHECK processing.</p> <ul style="list-style-type: none"> ■ Last Failure Parameter [0] contains the executive flags value. ■ Last Failure Parameter [1] contains the RIP from the machine fault stack. ■ Last Failure Parameter [2] contains the read diagnostic register 0 value. ■ Last Failure Parameter [3] contains the FX Chip CSR value. ■ Last Failure Parameter [4] contains the SIP last failure code value. 	01

Table 7-18 Last Failure Codes (Sheet 4 of 41)

Code	Description	Repair Action Code
011B0108	The I960 reported a machine fault (nonparity error). <ul style="list-style-type: none"> ■ Last Failure Parameter [0] contains the Fault Data (2) value. ■ Last Failure Parameter [1] contains the Fault Data (1) value. ■ Last Failure Parameter [2] contains the Fault Data (0) value. ■ Last Failure Parameter [3] contains the Number of Faults value. ■ Last Failure Parameter [4] contains the PC value. ■ Last Failure Parameter [5] contains the AC value. ■ Last Failure Parameter [6] contains the Fault Flags, Type and Subtype values. ■ Last Failure Parameter [7] contains the RIP value (actual). 	01
011C0011	Controller execution terminated via display of solid fault code in OCP LEDs. Note that upon receipt of this Last Failure in a last gasp message the other controller in a dual controller configuration will inhibit assertion of the KILL line. <ul style="list-style-type: none"> ■ Last Failure Parameter [0] contains the OCP LED solid fault code value. 	00
011D0100	Relocated zero (for example, C0000000) entered via call or branch.	01
018000A0	A powerfail interrupt occurred.	00
018600A0	A processor interrupt was generated with an indication that the other controller in a dual controller configuration asserted the KILL line to disable this controller.	00
018700A0	A processor interrupt was generated with an indication that the (//) RESET button on the controller module was depressed.	00
018800A0	A processor interrupt was generated with an indication that the program card was removed.	00
018900A0	A processor interrupt was generated with an indication that the controller inactivity watch dog timer expired.	00

Table 7-18 Last Failure Codes (Sheet 5 of 41)

Code	Description	Repair Action Code
018F2087	<p>A NMI interrupt was generated with an indication that a controller system problem occurred.</p> <ul style="list-style-type: none"> ■ Last Failure Parameter [0] contains the value of read diagnostic register 0. ■ Last Failure Parameter [1] contains the value of read diagnostic register 1. ■ Last Failure Parameter [2] contains PCI status. Bits 31::24 hold PCFX PSCR status and bits 15::08 hold PLX PSCR status. ■ Last Failure Parameter [3] contains the PCFX PDAL control/status register. ■ Last Failure Parameter [4] contains the IBUS address of error register. ■ Last Failure Parameter [5] contains the previous PDAL address of error register. ■ Last Failure Parameter [6] contains the current PDAL address of error register. 	20
01902086	<p>The PCI bus on the controller will not allow a master to initiate a transfer. Unable to provide further diagnosis of the problem.</p> <ul style="list-style-type: none"> ■ Last Failure Parameter [0] contains the value of read diagnostic register 0. ■ Last Failure Parameter [1] contains the value of read diagnostic register 1. ■ Last Failure Parameter [2] contains the value of read diagnostic register 2. ■ Last Failure Parameter [3] contains the value of write diagnostic register 0. ■ Last Failure Parameter [4] contains the value of write diagnostic register 1. ■ Last Failure Parameter [5] contains the IBUS address of error register. 	20
01910084	<p>A Cache Module was inserted or removed.</p> <ul style="list-style-type: none"> ■ Last Failure Parameter [0] contains the value of actual Cache Module A exists state. ■ Last Failure Parameter [1] contains the value of actual Cache Module B exists state. ■ Last Failure Parameter [2] contains the value of expected Cache Module A exists state. ■ Last Failure Parameter [3] contains the value of expected Cache Module B exists state. 	00
01920186	<p>Unable to read the FX because a Device Port or a Host Port locked the PDAL bus.</p> <ul style="list-style-type: none"> ■ Last Failure Parameter [0] contains the value of read diagnostic register 0. ■ Last Failure Parameter [1] contains the value of read diagnostic register 1. ■ Last Failure Parameter [2] contains the value of read diagnostic register 2. ■ Last Failure Parameter [3] contains the value of write diagnostic register 0. ■ Last Failure Parameter [4] contains the value of write diagnostic register 1. ■ Last Failure Parameter [5] contains the IBUS address of error register. 	01

Table 7-18 Last Failure Codes (Sheet 6 of 41)

Code	Description	Repair Action Code
01932588	An error has occurred on the <i>CDAL</i> . <ul style="list-style-type: none"> ■ Last Failure Parameter [0] contains the value of read diagnostic register 0. ■ Last Failure Parameter [1] contains the value of read diagnostic register 1. ■ Last Failure Parameter [2] contains the value of write diagnostic register 0. ■ Last Failure Parameter [3] contains the value of write diagnostic register 1. ■ Last Failure Parameter [4] contains the IBUS address of error register. ■ Last Failure Parameter [5] contains the PCFX <i>CDAL</i> control / status register. ■ Last Failure Parameter [6] contains the previous <i>CDAL</i> address of error register. ■ Last Failure Parameter [7] contains the current <i>CDAL</i> address of error register. 	25
01942088	Applies to <i>PDAL</i> .	20
01950188	An error has occurred that caused the FX to be rest, when not permissible. <ul style="list-style-type: none"> ■ Last Failure Parameter [0] contains the value of read diagnostic register 0. ■ Last Failure Parameter [1] contains the value of read diagnostic register 1. ■ Last Failure Parameter [2] contains the value of write diagnostic register 0. ■ Last Failure Parameter [3] contains the value of write diagnostic register 1. ■ Last Failure Parameter [4] contains the IBUS address of error register. ■ Last Failure Parameter [5] contains the PCFX <i>PDAL</i> control / status register. ■ Last Failure Parameter [6] contains the PCFX <i>CDAL</i> control / status register. ■ Last Failure Parameter [7] contains the current <i>PDAL</i> address of error register. 	01
01960186	The Ibus is inaccessible. <ul style="list-style-type: none"> ■ Last Failure Parameter [0] contains the value of read diagnostic register 0. ■ Last Failure Parameter [1] contains the value of read diagnostic register 1. ■ Last Failure Parameter [2] contains the value of read diagnostic register 2. ■ Last Failure Parameter [3] contains the value of write diagnostic register 0. ■ Last Failure Parameter [4] contains the value of write diagnostic register 1. ■ Last Failure Parameter [5] contains the IBUS address of error register. 	01

Table 7-18 Last Failure Codes (Sheet 7 of 41)

Code	Description	Repair Action Code
01970188	Software indicates all NMI causes cleared, but some remain. <ul style="list-style-type: none"> ■ Last Failure Parameter [0] contains the value of read diagnostic register 0. ■ Last Failure Parameter [1] contains the value of read diagnostic register 1. ■ Last Failure Parameter [2] contains the value of read diagnostic register 2. ■ Last Failure Parameter [3] contains the value of write diagnostic register 0. ■ Last Failure Parameter [4] contains the value of write diagnostic register 1. ■ Last Failure Parameter [5] contains the IBUS address of error register. ■ Last Failure Parameter [6] contains the PCFX PDAL control / status register. ■ Last Failure Parameter [7] contains the PCFX CDAL control / status register. 	01
01982087	The Ibus encountered a parity error. <ul style="list-style-type: none"> ■ Last Failure Parameter [0] contains the value of read diagnostic register 0. ■ Last Failure Parameter [1] contains the value of read diagnostic register 1. ■ Last Failure Parameter [2] contains the value of read diagnostic register 2. ■ Last Failure Parameter [3] contains the value of write diagnostic register 0. ■ Last Failure Parameter [4] contains the value of write diagnostic register 1. ■ Last Failure Parameter [5] contains the IBUS address of error register. ■ Last Failure Parameter [6] contains the RIP. 	20
01992088	An error was detected by the PLX. <ul style="list-style-type: none"> ■ Last Failure Parameter [0] contains the value of read diagnostic register 0. ■ Last Failure Parameter [1] contains the value of read diagnostic register 1. ■ Last Failure Parameter [2] contains the value of write diagnostic register 0. ■ Last Failure Parameter [3] contains the value of write diagnostic register 1. ■ Last Failure Parameter [4] contains the IBUS address of error register. ■ Last Failure Parameter [5] contains the PLX status register. ■ Last Failure Parameter [6] contains the previous PDAL address of error register. ■ Last Failure Parameter [7] contains the RIP. 	20

Table 7-18 Last Failure Codes (Sheet 8 of 41)

Code	Description	Repair Action Code
019A2093	Hardware Port Hardware failure - TACHYON. <ul style="list-style-type: none"> ■ Last Failure Parameter [0] contains failed port number. ■ Last Failure Parameter [1] contains gluon status. ■ Last Failure Parameter [2] contains TACHYON status. 	20
02010100	Initialization code was unable to allocate enough memory to set up the send data descriptors.	01
02040100	Unable to allocate memory necessary for data buffers.	01
02050100	Unable to allocate memory for the Free Buffer Array.	01
02080100	A call to EXEC\$ALLOCATE_MEM_ZEROED failed to return memory when populating the <i>disk read</i> DWD stack.	01
02090100	Applies to <i>disk write</i> .	
020C0100	Applies to <i>miscellaneous</i> .	
02100100	A call to EXEC\$ALLOCATE_MEM_ZEROED failed to return memory when creating the device services state table.	01
02170100	Unable to allocate memory for the Free Node Array.	01
021D0100	Unable to allocate memory for the Free Buffer Array.	01
021F0100	Unable to allocate memory for WARPs and RMDs.	01
02210100	Invalid parameters in CACHE\$OFFER_META call.	01
02220100	No buffer found for CACHE\$MARK_META_DIRTY call.	01
02270104	A callback from DS on a transfer request has returned a bad or illegal DWD status. <ul style="list-style-type: none"> ■ Last Failure Parameter [0] contains the DWD Status. ■ Last Failure Parameter [1] contains the DWD address. ■ Last Failure Parameter [2] contains the PUB address. ■ Last Failure Parameter [3] contains the Device Port. 	01
022C0100	A <i>READ_LONG</i> operation was requested for a Local Buffer Transfer. <i>READ_LONG</i> is not supported for Local Buffer Transfers.	01
022D0100	Applies to <i>WRITE_LONG</i> .	
02380102	An invalid status was returned from CACHE\$LOCK_READ(). <ul style="list-style-type: none"> ■ Last Failure Parameter [0] contains the DD address. ■ Last Failure Parameter [1] contains the invalid status. 	01

Table 7-18 Last Failure Codes (Sheet 9 of 41)

Code	Description	Repair Action Code
023A2084	A processor interrupt was generated by the controller's XOR engine (FX), indicating an unrecoverable error condition. <ul style="list-style-type: none"> ■ Last Failure Parameter [0] contains the FX Control and Status Register (CSR). ■ Last Failure Parameter [1] contains the FX DMA Indirect List Pointer register (DILP). ■ Last Failure Parameter [2] contains the FX DMA Page Address register (DADDR). ■ Last Failure Parameter [3] contains the FX DMA Command and control register (DCMD). 	20
02440100	The logical unit mapping type was detected invalid in <code>va_set_disk_geometry()</code> .	01
02530102	An invalid status was returned from <code>CACHE\$LOOKUP_LOCK()</code> .	01
02560102	<ul style="list-style-type: none"> ■ Last Failure Parameter[0] contains the DD address. ■ Last Failure Parameter[1] contains the invalid status. 	
02570102	An invalid status was returned from <code>VA\$XFER()</code> during an operation. <ul style="list-style-type: none"> ■ Last Failure Parameter[0] contains the DD address. ■ Last Failure Parameter[1] contains the invalid status. 	01
025A0102	An invalid status was returned from <code>CACHE\$LOOKUP_LOCK()</code> . <ul style="list-style-type: none"> ■ Last Failure Parameter[0] contains the DD address. ■ Last Failure Parameter[1] contains the invalid status. 	01
02690102	An invalid status was returned from <code>CACHE\$OFFER_WRITE_DATA()</code> . <ul style="list-style-type: none"> ■ Last Failure Parameter[0] contains the DD address. ■ Last Failure Parameter[1] contains the invalid status. 	01
027B0102	An invalid status was returned from <code>VA\$XFER()</code> in a complex ACCESS operation. <ul style="list-style-type: none"> ■ Last Failure Parameter[0] contains the DD address. ■ Last Failure Parameter[1] contains the invalid status. 	01
027D0100 027E0100 027F0100 02800100	Unable to allocate memory for a Failover Control Block.	01
02840100	Unable to allocate memory for the XNode Array.	01
02860100	Unable to allocate memory for the Fault Management Event Information Packet used by the Cache Manager in generating error logs to the host.	01
02880100	Invalid FOC Message in <code>cmfoc_snd_cmd</code> .	01

Table 7-18 Last Failure Codes (Sheet 10 of 41)

Code	Description	Repair Action Code
028A0100 028B0100	Invalid return status from DIAG\$CACHE_MEMORY_TEST.	01
028C0100	Invalid error status given to cache_fail.	01
028E0100	Invalid DCA state detected in init_crashover.	01
02910100	Invalid metadata combination detected in build_raid_node.	01
02920100	Unable to handle that many bad dirty pages (exceeded MAX_BAD_DIRTY). Cache memory is bad.	01
02930100	There was no free or freeable buffer to convert bad metadata or to borrow a buffer during failover of bad dirty.	01
02940100	A free Device Correlation Array entry could not be found during write-back cache failover.	01
02950100	Invalid DCA state detected in start_crashover.	01
02960100	Invalid DCA state detected in start_failover.	01
02970100	Invalid DCA state detected in init_failover.	01
02990100	A free RAID Correlation Array entry could not be found during write-back cache failover.	01
029A0100	Invalid cache buffer metadata detected while scanning the Buffer Metadata Array. Found a page containing dirty data but the corresponding Device Correlation Array entry does exist.	01
029D0100	Invalid metadata combination detected in build_bad_raid_node.	01
029F0100	The Cache Manager software has insufficient resources to handle a buffer request pending.	01
02A00100	VA change state is trying to change device affinity and the cache has data for this device.	01
02A10100 02A20100	Pubs not one when transportable.	01
02A30100	No available data buffers. If the cache module exists then this is true after testing the whole cache. Otherwise there were no buffers allocated from BUFFER memory on the controller module.	01
02A40100	A call to EXEC\$ALLOCATE_MEM_ZEROED failed to return memory when allocating <i>VAXDs</i> .	01
02A50100	Applies to <i>DILPs</i> .	
02A60100	A call to EXEC\$ALLOCATE_MEM_ZEROED failed to return memory when allocating <i>Change State Work Items</i> .	01
02A70100	Applies to <i>VA Request Items</i> .	

Table 7-18 Last Failure Codes (Sheet 11 of 41)

Code	Description	Repair Action Code
02A90100	Too many pending FOC\$SEND requests by the Cache Manager. Code is not designed to handle more than one FOC\$SEND to be pending because there is no reason to expect more than one pending.	01
02AA0100	An invalid call was made to CACHE\$DEALLOCATE_CLD. Either that device had dirty data or it was bound to a RAIDset.	01
02AB0100	An invalid call was made to CACHE\$DEALLOCATE_SLD. A RAIDset member either had dirty data or write-back already turned on.	01
02AC0100	An invalid call was made to CACHE\$DEALLOCATE_SLD. The RAIDset still has data (strip nodes).	01
02AD0180	The FX detected a compare error for data that was identical. This error has always previously occurred due to a hardware problem.	01
02AE0100	The mirrorset member count and individual member states are inconsistent. Discovered during a mirrorset write or erase.	01
02AF0102	An invalid status was returned from VAX\$FER() in a <i>write</i> operation. <ul style="list-style-type: none"> ■ Last Failure Parameter[0] contains the DD address. ■ Last Failure Parameter[1] contains the invalid status. 	01
02B00102	Applies to <i>erase</i> .	
02B10100	A mirrorset read operation was received and the round robin selection algorithm found no normal members in the mirrorset. Internal inconsistency.	01
02B20102	An invalid status was returned from CACHE\$LOCK_READ during a mirror copy operation. <ul style="list-style-type: none"> ■ Last Failure Parameter[0] contains the DD address. ■ Last Failure Parameter[1] contains the invalid status. 	01
02B30100	CACHE\$CHANGE_MIRROR_MODE invoked illegally (cache bad, dirty data still resident in the cache.)	01
02B90100	Invalid code loop count attempting to find the Cache ID Blocks.	01
02BD0100	A mirrorset metadata online operation found no normal members in the mirrorset. Internal inconsistency.	01
02BE0100	No free pages in the other cache. In performing mirror cache failover, a bad page was found, and an attempt was made to recover the data from the good copy (primary/mirror), but no free good page was found on the other cache to copy the data to.	01

Table 7-18 Last Failure Codes (Sheet 12 of 41)

Code	Description	Repair Action Code
02BF0100	Report_error routine encountered an unexpected failure status returned from DIAG\$LOCK_AND_TEST_CACHE_B.	01
02C00100	Copy_buff_on_this routine expected the given page to be marked bad and it was not.	01
02C10100	Copy_buff_on_other routine expected the given page to be marked bad and it was not.	01
02C30100	CACHE\$CREATE_MIRROR was invoked by C_SWAP under unexpected conditions (e.g., other controller not dead, bad lock state).	01
02C60100	Mirroring transfer found CLD with writeback state OFF.	01
02C70100	Bad BBR offsets for active shadowset, detected on <i>write</i> .	01
02C80100	Applies to <i>read</i> .	
02C90100	Illegal call made to CACHE\$PURGE_META when the storageset was not quiesced.	01
02CA0100	Illegal call made to VA\$RAID5_META_READ when another read (of metadata) is already in progress on the same strip.	01
02CB0000	A restore of the configuration has been done. This cleans up and restarts with the new configuration.	00
02CC0100	On an attempt, which is not allowed to fail, to allocate a cache node, no freeable cache node was found.	01
02D00100	Not all alter_device requests from VA_SAVE_CONFIG completed within the timeout interval.	01
02D30100	The controller has insufficient memory to allocate enough data structures used to manage metadata operations.	01
02D60100	An invalid storage set type was specified for metadata initialization.	01
02D90100	Bad CLD pointer passed setwb routine.	01
02DA0100	A fatal logic error occurred while trying to restart a stalled data transfer stream.	01
02DB0100	A call to EXEC\$ALLOCATE_MEM_ZEROED failed to return memory when populating the <i>disk read</i> PCX DWD stack.	01
02DC0100	Applies to <i>disk write</i> .	
02DD0101	The VA state change deadman timer expired, and at least one VSI was still interlocked. Last Failure Parameter [0] contains the nv_index.	01
02DE0100	An attempt to allocate memory for a null pub failed to get the memory.	01
02DF0101	License identified in Last Failure Parameter [0] was not forced valid.	01
02E00180	Mirror functionality is broken.	01

Table 7-18 Last Failure Codes (Sheet 13 of 41)

Code	Description	Repair Action Code
02E11016	<p>While attempting to restore saved configuration information, data for two unrelated controllers was found. The restore code is unable to determine which disk contains the correct information. The Port/Target/LUN information for the two disks is contained in the parameter list. Remove the disk containing the incorrect information, reboot the controller, and issue the SET THIS_CONTROLLER INITIAL_CONFIGURATION command. When the controller restarts, the proper configuration will be loaded.</p> <ul style="list-style-type: none"> ■ Last Failure Parameter [0] contains the first disk port. ■ Last Failure Parameter [1] contains the first disk target. ■ Last Failure Parameter [2] contains the first disk LUN. ■ Last Failure Parameter [3] contains the second disk port. ■ Last Failure Parameter [4] contains the second disk target. ■ Last Failure Parameter [5] contains the second disk LUN. 	10
02E20100	An attempt to allocate a va_cs_work item from the S_va_free_cs_work_queue failed.	01
02E30100	An attempt to allocate a free VAR failed.	01
02E40100		
02E50100		
02E60100		
02E70100		
02E80100		
02E90100		
02EA0100		
02EB0100	An attempt to allocate a free metadata WARP failed.	01
02EC0101	<p>An online request was received for a unit when both controllers had dirty data for the unit. The crash is to allow the surviving controller to copy over all of the dirty data.</p> <ul style="list-style-type: none"> ■ Last Failure Parameter [0] contains the nv_index of the unit. 	01
02ED0100	On an attempt, which is not allowed to fail, to allocate a BDB, no freeable BDB was found.	01
02EE0102	<p>A CLD is already allocated when it should be free.</p> <ul style="list-style-type: none"> ■ Last Failure Parameter [0] contains the requesting entity. ■ Last Failure Parameter [1] contains the CLD index. 	01

Table 7-18 Last Failure Codes (Sheet 14 of 41)

Code	Description	Repair Action Code
02EF0102	A CLD is free when it should be allocated. <ul style="list-style-type: none"> ■ Last Failure Parameter [0] contains the requesting entity. ■ Last Failure Parameter [1] contains the CLD index. 	01
02F00100	The controller has insufficient free resources for the configuration restore process to obtain a facility lock.	01
02F10102	The configuration restore process encountered an unexpected non-volatile parameter store format. The process cannot restore from this version. <ul style="list-style-type: none"> ■ Last Failure Parameter [0] contains the version found. ■ Last Failure Parameter [1] contains the expected version. 	01
02F20100	The controller has insufficient free resources for the configuration restore process to release a facility lock.	01
02F34083	A device read operation failed during the configuration restore operation. The controller is crashed to prevent possible loss of saved configuration information on other functioning devices. <ul style="list-style-type: none"> ■ Last Failure Parameter [0] contains the disk port. ■ Last Failure Parameter [1] contains the disk target. ■ Last failure Parameter [2] contains the disk LUN. 	40
02F44083	The calculated error detection code on the saved configuration information is bad. The controller is crashed to prevent destruction of other copies of the saved configuration information. Remove the device with the bad information and retry the operation. <ul style="list-style-type: none"> ■ Last Failure Parameter [0] contains the disk port. ■ Last Failure Parameter [1] contains the disk target. ■ Last Failure Parameter [2] contains the disk LUN. 	40
02F54083	The device saved configuration information selected for the restore process is from an unsupported controller type. Remove the device with the unsupported information and retry the operation. <ul style="list-style-type: none"> ■ Last Failure Parameter [0] contains the disk port. ■ Last Failure Parameter [1] contains the disk target. ■ Last Failure Parameter [2] contains the disk LUN. 	40

Table 7-18 Last Failure Codes (Sheet 15 of 41)

Code	Description	Repair Action Code
02F60103	<p>An invalid modification to the no_interlock VSI flag was attempted.</p> <ul style="list-style-type: none"> ■ Last Failure Parameter [0] contains the nv_index of the config on which the problem was found. ■ Last Failure Parameter [1] contains modification flag. ■ Last Failure Parameter [2] contains the current value of the no_interlock flag. <p>If the modification flag is 1, then an attempt was being made to set the no_interlock flag, and the no_interlock flag was not clear at the time. If the modification flag is 0, then an attempt was being made to clear the no_interlock flag, and the no_interlock flag was not set (== 1) at the time.</p>	01
02F70100	<p>During boot testing, one or more device ports (SCSI) were found to be bad. Due to a problem in the SYMBIOS 770 chip, the diagnostic may occasionally fail the port even though the hardware is OKAY. A reboot should clear up the problem. If the port is actually broken, logic to detect a loop that repeatedly causes the same bugcheck will cause a halt.</p>	01
02F80103	<p>An attempt was made to bring a unit online when the cache manager says that a member CLD was not in the appropriate state.</p> <ul style="list-style-type: none"> ■ Last Failure Parameter [0] contains the nv_index of the config on which the problem was found. ■ Last Failure Parameter [1] contains the map type of that config. ■ Last Failure Parameter [2] contains the value from CACHE\$CHECK_CID that was not acceptable. 	01
02F90100	<p>A call to EXEC\$ALLOCATE_MEM_ZEROED failed to return memory when allocating structures for read ahead caching.</p>	01
02FA0100	<p>A read ahead caching data structure (RADD) is inconsistent.</p>	01
02FB2084	<p>A processor interrupt was generated by the controller's XOR engine (FX), indicating an unrecoverable error condition.</p> <ul style="list-style-type: none"> ■ Last Failure Parameter [0] contains the FX Control and Status Register (CSR). ■ Last Failure Parameter [1] contains the FX DMA Indirect List Pointer register (DILP). ■ Last Failure Parameter [2] contains the FX DMA Page Address register (DADDR). ■ Last Failure Parameter [3] contains the FX DMA Command and control register (DCMD). 	20
02FC0180	<p>The FX detected a compare error for data that was identical. This error has always previously occurred due to a hardware problem.</p>	01

Table 7-18 Last Failure Codes (Sheet 16 of 41)

Code	Description	Repair Action Code
02FD0100	The controller has insufficient free memory to restore saved configuration information from disk.	01
02FE0105	A field in the VSI was not cleared when an attempt was made to clear the interlock. <ul style="list-style-type: none"> ■ Last Failure Parameter [0] contains the NV index of the VSI on which the problem was found. ■ Last Failure Parameter [1] contains the contents of the enable_change field of the VSI, which should be zero. ■ Last Failure Parameter [2] contains the contents of the desired_state field of the VSI, which should be zero. ■ Last Failure Parameter [3] contains the contents of the completion_routine field of the VSI, which should be zero. ■ Last Failure Parameter [4] contains the contents of the open_requests field of the VSI, which should be zero. 	01
03010100	Failed request for port-specific scripts memory allocation.	01
03020101	Invalid SCSI direct-access device opcode in misc command DWD. <ul style="list-style-type: none"> ■ Last Failure Parameter [0] contains the SCSI command opcode. 	01
03040101	Invalid SCSI CDROM device opcode in misc command DWD. <ul style="list-style-type: none"> ■ Last Failure Parameter [0] contains the SCSI command opcode. 	01
03060101	Invalid SCSI device type in PUB. <ul style="list-style-type: none"> ■ Last Failure Parameter [0] contains the SCSI device type. 	01
03070101	Invalid CDB Group Code detected during create of misc cmd DWD <ul style="list-style-type: none"> ■ Last Failure Parameter [0] contains the SCSI command opcode. 	01
03080101	Invalid SCSI OPTICAL MEMORY device opcode in misc command DWD. <ul style="list-style-type: none"> ■ Last Failure Parameter [0] contains the SCSI command opcode. 	01
03090101	Failed request for allocation of PCI miscellaneous block. <ul style="list-style-type: none"> ■ Last Failure Parameter [0] contains the failed dwd command class. 	01
030A0100	Error DWD not found in port in_proc_q.	01

Table 7-18 Last Failure Codes (Sheet 17 of 41)

Code	Description	Repair Action Code
030B0188	A dip error was detected when pcb_busy was set. <ul style="list-style-type: none"> ■ Last Failure Parameter [0] contains the PCB port_ptr value. ■ Last Failure Parameter [1] contains the new info NULL-SSTAT0-DSTAT-ISTAT. ■ Last Failure Parameter [2] contains the PCB copy of the device port DBC register. ■ Last Failure Parameter [3] contains the PCB copy of the device port DNAD register. ■ Last Failure Parameter [4] contains the PCB copy of the device port DSP register. ■ Last Failure Parameter [5] contains the PCB copy of the device port DSPS register. ■ Last Failure Parameter [6] contains the PCB copies of the device port SSTAT2/SSTAT1/SSTAT0/DSTAT registers. ■ Last Failure Parameter [7] contains the PCB copies of the device port LCRC/RESERVED/ISTAT/DFIFO registers. 	01
031E0100	Can't find in_error_dwd on in-process queue.	01
031F0100	Either DWD_ptr is null or bad value in dsps.	01
03280100	SCSI CDB contains an invalid group code for a transfer command.	01
03290100	The required Error Information Packet (EIP) or Device Work Descriptor (DWD) were not supplied to the Device Services error logging code.	01
032B0100	A Device Work Descriptor (DWD) was supplied with a NULL Physical Unit Block (PUB) pointer.	01
03320101	An invalid code was passed to the error recovery thread in the error_stat field of the PCB. <ul style="list-style-type: none"> ■ Last Failure Parameter[0] contains the PCB error_stat code. 	01
03330188	A parity error was detected by a device port while sending data out onto the SCSI bus. <ul style="list-style-type: none"> ■ Last Failure Parameter [0] contains the PCB port_ptr value. ■ Last Failure Parameter [1] contains the PCB copy of the device port TEMP register. ■ Last Failure Parameter [2] contains the PCB copy of the device port DBC register. ■ Last Failure Parameter [3] contains the PCB copy of the device port DNAD register. ■ Last Failure Parameter [4] contains the PCB copy of the device port DSP register. ■ Last Failure Parameter [5] contains the PCB copy of the device port DSPS register. ■ Last Failure Parameter [6] contains the PCB copies of the device port SSTAT2/SSTAT1/SSTAT0/DSTAT registers. ■ Last Failure Parameter [7] contains the PCB copies of the device port LCRC/RESERVED/ISTAT/DFIFO registers. 	01

Table 7-18 Last Failure Codes (Sheet 18 of 41)

Code	Description	Repair Action Code
03370108	<p>A device port detected an illegal script instruction.</p> <ul style="list-style-type: none"> ■ Last Failure Parameter [0] contains the PCB port_ptr value. ■ Last Failure Parameter [1] contains the PCB copy of the device port TEMP register. ■ Last Failure Parameter [2] contains the PCB copy of the device port DBC register. ■ Last Failure Parameter [3] contains the PCB copy of the device port DNAD register. ■ Last Failure Parameter [4] contains the PCB copy of the device port DSP register. ■ Last Failure Parameter [5] contains the PCB copy of the device port DSPTS register. ■ Last Failure Parameter [6] contains the PCB copies of the device port SSTAT2/SSTAT1/SSTAT0/DSTAT registers. ■ Last Failure Parameter [7] contains the PCB copies of the device port LCRC/RESERVED/ISTAT/DFIFO registers. 	01
03380188	<p>A device port's DSTAT register contains multiple asserted bits, or an invalidly asserted bit, or both.</p> <ul style="list-style-type: none"> ■ Last Failure Parameter [0] contains the PCB port_ptr value. ■ Last Failure Parameter [1] contains the PCB copy of the device port TEMP register. ■ Last Failure Parameter [2] contains the PCB copy of the device port DBC register. ■ Last Failure Parameter [3] contains the PCB copy of the device port DNAD register. ■ Last Failure Parameter [4] contains the PCB copy of the device port DSP register. ■ Last Failure Parameter [5] contains the PCB copy of the device port DSPTS register. ■ Last Failure Parameter [6] contains the PCB copies of the device port SSTAT2/SSTAT1/SSTAT0/DSTAT registers. ■ Last Failure Parameter [7] contains the PCB copies of the device port LCRC/RESERVED/ISTAT/DFIFO registers. 	01

Table 7-18 Last Failure Codes (Sheet 19 of 41)

Code	Description	Repair Action Code
03390108	<p>An unknown interrupt code was found in a device port's DSPS register.</p> <ul style="list-style-type: none"> ■ Last Failure Parameter [0] contains the PCB port_ptr value. ■ Last Failure Parameter [1] contains the PCB copy of the device port TEMP register. ■ Last Failure Parameter [2] contains the PCB copy of the device port DBC register. ■ Last Failure Parameter [3] contains the PCB copy of the device port DNAD register. ■ Last Failure Parameter [4] contains the PCB copy of the device port DSP register. ■ Last Failure Parameter [5] contains the PCB copy of the device port DSPS register. ■ Last Failure Parameter [6] contains the PCB copies of the device port SSTAT2/SSTAT1/SSTAT0/DSTAT registers. <p>Last Failure Parameter [7] contains the PCB copies of the device port LCRC/RESERVED/ISTAT/DFIFO registers.</p>	01
033C0101	<p>An invalid code was seen by the error recovery thread in the er_func_step field of the PCB.</p> <ul style="list-style-type: none"> ■ Last Failure Parameter [0] contains the PCB er_func_step code. 	01
033E0108	<p>An attempt was made to restart a device port at the SDP DBD.</p> <ul style="list-style-type: none"> ■ Last Failure Parameter [0] contains the PCB port_ptr value. ■ Last Failure Parameter [1] contains the PCB copy of the device port TEMP register. ■ Last Failure Parameter [2] contains the PCB copy of the device port DBC register. ■ Last Failure Parameter [3] contains the PCB copy of the device port DNAD register. ■ Last Failure Parameter [4] contains the PCB copy of the device port DSP register. ■ Last Failure Parameter [5] contains the PCB copy of the device port DSPS register. ■ Last Failure Parameter [6] contains the PCB copies of the device port SSTAT2/SSTAT1/SSTAT0/DSTAT registers. ■ Last Failure Parameter [7] contains the PCB copies of the device port LCRC/RESERVED/ISTAT/DFIFO registers. 	01

Table 7-18 Last Failure Codes (Sheet 20 of 41)

Code	Description	Repair Action Code
033F0108	An EDC error was detected on a read of a soft-sectored device path not yet implemented. <ul style="list-style-type: none"> ■ Last Failure Parameter [0] contains the PCB port_ptr value. ■ Last Failure Parameter [1] contains the PCB copy of the device port TEMP register. ■ Last Failure Parameter [2] contains the PCB copy of the device port DBC register. ■ Last Failure Parameter [3] contains the PCB copy of the device port DNAD register. ■ Last Failure Parameter [4] contains the PCB copy of the device port DSP register. ■ Last Failure Parameter [5] contains the PCB copy of the device port DSPS register. ■ Last Failure Parameter [6] contains the PCB copies of the device port SSTAT2/SSTAT1/SSTAT0/DSTAT registers. ■ Last Failure Parameter [7] contains the PCB copies of the device port LCRC/RESERVED/ISTAT/DFIFO registers. 	01
03410101	Invalid SCSI device type in PUB. <ul style="list-style-type: none"> ■ Last Failure Parameter [0] contains the PUB SCSI device type. 	01
03450188	A Master Data Parity Error was detected by a port. <ul style="list-style-type: none"> ■ Last Failure Parameter [0] contains the PCB port_ptr value. ■ Last Failure Parameter [1] contains the PCB copies of the device port DCMD/DBC registers. ■ Last Failure Parameter [2] contains the PCB copy of the device port DNAD register. ■ Last Failure Parameter [3] contains the PCB copy of the device port DSP register. ■ Last Failure Parameter [4] contains the PCB copy of the device port DSPS register. ■ Last Failure Parameter [5] contains the PCB copies of the device port DSTAT/SSTAT0/SSTAT1/SSTAT2 registers. ■ Last Failure Parameter [6] contains the PCB copies of the device port DFIFO/ISTAT/SBCL/RESERVED registers. ■ Last Failure Parameter [7] contains the PCB copies of the device port SIST0/SIST1/SXFER/SCNTL3 registers. 	01
03470100	Insufficient memory available for target block allocation.	01
03480100	Insufficient memory available for device port info block allocation.	01
03490100	Insufficient memory available for autoconfig buffer allocation.	01
034A0100	Insufficient memory available for PUB allocation.	01

Table 7-18 Last Failure Codes (Sheet 21 of 41)

Code	Description	Repair Action Code
034B0100	Insufficient memory available for DS init buffer allocation.	01
034C0100	Insufficient memory available for static structure allocation.	01
034D0100	DS init DWDs exhausted.	01
034E2080	Diagnostics report all device ports are broken.	20
034F0100	Insufficient memory available for reselect target block allocation.	01
03500100	Insufficient memory available for command disk allocation.	01
03520100	A failure resulted when an attempt was made to allocate a DWD for use by DS CDI.	01
03530102	A DWD with an illegal address has been found. <ul style="list-style-type: none"> ■ Last Failure Parameter [0] contains the bad DWD pointer. ■ Last Failure Parameter [1] contains the corresponding PCB pointer. 	01
035A0100	Invalid SCSI message byte passed to DS.	01
035B0100	Insufficient DWD resources available for SCSI message passthrough.	01
03640100	Processing run_switch disabled for LOGDISK associated with the other controller.	01
03650100	Processing pub unblock for LOGDISK associated with the other controller.	01
03660100	No memory available to allocate pub to tell the other controller of <i>reset</i> to one if its LUNs.	01
03670100	Applies to a <i>BDR</i> .	
036F0101	Either send_sdtr or send_wdtr flag set in a non-miscellaneous DWD. <ul style="list-style-type: none"> ■ Last Failure Parameter [0] contains the invalid command class type. 	01
03780181	In ds_get_resume_addr, the buffer address is non-longword aligned for FX access. <ul style="list-style-type: none"> ■ Last Failure Parameter [0] contains the re-entry dbd address value. 	01

Table 7-18 Last Failure Codes (Sheet 22 of 41)

Code	Description	Repair Action Code
03790188	A PCI bus fault was detected by a device port. <ul style="list-style-type: none"> ■ Last Failure Parameter [0] contains the PCB port_ptr value. ■ Last Failure Parameter [1] contains the PCB copy of the device port TEMP register. ■ Last Failure Parameter [2] contains the PCB copy of the device port DBC register. ■ Last Failure Parameter [3] contains the PCB copy of the device port DNAD register. ■ Last Failure Parameter [4] contains the PCB copy of the device port DSP register. ■ Last Failure Parameter [5] contains the PCB copy of the device port DSPS register. ■ Last Failure Parameter [6] contains the PCB copies of the device port SSTAT2/SSTAT1/SSTAT0/DSTAT registers. ■ Last Failure Parameter [7] contains the PCB copies of the device port LCRC/RESERVED/ISTAT/DFIFO registers. 	01
03820100	Failed request for mapping table memory allocation.	01
03830100	Failed request PCI 875 block memory allocation.	01
03850101	ds_alloc_mem called with invalid memory type. <ul style="list-style-type: none"> ■ Last Failure Parameter [0] contains the invalid memory type. 	01
03860100	ds_alloc_mem was unable to get requested memory allocated: NULL pointer returned.	01
038C0100	Insufficient memory available for completion dwd array allocation.	01
03980100	Failed to allocate expandable EMU static work structures.	01
03990100	Failed to allocate expandable EMU work entry.	01
039A0100	Failed to allocate expandable EMU FOC work entry.	01
039B0100	EMU request work queue corrupted.	01
039C0100	EMU response work queue corrupted.	01
039D0100	EMU work queue corrupted.	01
039E0100	EMU foc request work queue corrupted.	01
039F0100	EMU foc response work queue corrupted.	01

Table 7-18 Last Failure Codes (Sheet 23 of 41)

Code	Description	Repair Action Code
03A08093	<p>A configuration or hardware error was reported by the EMU.</p> <ul style="list-style-type: none"> ■ Last Failure Parameter [0] contains the solid OCP pattern which identifies the type of problem encountered. ■ Last Failure Parameter [1] contains the cabinet ID reporting the problem. ■ Last Failure Parameter [2] contains the SCSI Port number where the problem exists (if port-specific). 	80
03A28193	<p>The EMU reported Terminator Power out of range.</p> <ul style="list-style-type: none"> ■ Last Failure Parameter [0] contains a bit mask indicating which SCSI Port number(s) where the problem exists for cab 0. Bit 0 set indicates SCSI Port 1, Bit 1 set indicates SCSI port 2, etc. ■ Last Failure Parameter [1] contains a bit mask indicating which SCSI Port number(s) where the problem exists for cab 2. ■ Last Failure Parameter [2] contains a bit mask indicating which SCSI Port number(s) where the problem exists for cab 3. 	81
03A30790	The EMU in cab 0 is performing an emergency shutdown because there are less than four functioning power supplies.	07
03A40D90	The EMU in cab 0 is performing an emergency shutdown because it has determined that the temperature is above the maximum limit.	0D
03A50690	The EMU in cab 0 is performing an emergency shutdown because a fan has been missing for more than 8 minutes.	06
04010101	<p>The requester id component of the instance code passed to FM\$REPORT_EVENT is larger than the maximum allowed for this environment.</p> <ul style="list-style-type: none"> ■ Last Failure Parameter[0] contains the instance code value. 	01
04020102	<p>The requester's error table index passed to FM\$REPORT_EVENT is larger than the maximum allowed for this requester.</p> <ul style="list-style-type: none"> ■ Last Failure Parameter[0] contains the instance code value. ■ Last Failure Parameter[1] contains the requester error table index value. 	01
04030102	<p>The USB index supplied in the Event Information Packet (EIP) is larger than the maximum number of USBs.</p> <ul style="list-style-type: none"> ■ Last Failure Parameter[0] contains the instance code value. ■ Last Failure Parameter[1] contains the USB index value. 	01

Table 7-18 Last Failure Codes (Sheet 24 of 41)

Code	Description	Repair Action Code
04040103	The event log format found in V_fm_template_table is not supported by the Fault Manager. The bad format was discovered while trying to fill in a supplied Event Information Packet (EIP). <ul style="list-style-type: none"> ■ Last Failure Parameter[0] contains the instance code value. ■ Last Failure Parameter[1] contains the format code value. ■ Last Failure Parameter[2] contains the requester error table index value. 	01
04050100	The Fault Manager could not allocate memory for its Event Information Packet (EIP) buffers.	01
040A0100	The caller of FM\$CANCEL_SCSI_DE_NOTIFICATION passed an address of a deferred error notification routine which doesn't match the address of any routines for which deferred error notification is enabled.	01
040E0100	FM\$ENABLE_DE_NOTIFICATION was called to enable deferred error notification but the specified routine was already enabled to receive deferred error notification.	01
040F0102	The eip->generic.mscp1.flgs field of the EIP passed to FM\$REPORT_EVENT contains an invalid flag. <ul style="list-style-type: none"> ■ Last Failure Parameter[0] contains the instance code value. ■ Last Failure Parameter[1] contains the value supplied in the eip->generic.mscp1.flgs field. 	01
04100101	Unexpected template type found during fmu_display_errlog processing. Last Failure Parameter[0] contains the unexpected template value.	01
04110101	Unexpected instance code found during fmu_memerr_report processing. <ul style="list-style-type: none"> ■ Last Failure Parameter[0] contains the unexpected instance code value. 	01
04120101	CLIB\$SDD_FA0 call failed. <ul style="list-style-type: none"> ■ Last Failure Parameter[0] contains the failure status code value. 	01
04140103	The template value found in the eip is not supported by the Fault Manager. The bad template value was discovered while trying to build an esd. <ul style="list-style-type: none"> ■ Last Failure Parameter [0] contains the instance code value. ■ Last Failure Parameter [1] contains the template code value. ■ Last Failure Parameter [2] contains the requester error table index value. 	01

Table 7-18 Last Failure Codes (Sheet 25 of 41)

Code	Description	Repair Action Code
04170102	The template value found in the esd is not supported by the Fault Manager. The bad template value was discovered while trying to translate an esd into an eip. <ul style="list-style-type: none"> ■ Last Failure Parameter [0] contains the instance code value. ■ Last Failure Parameter [1] contains the template code value. 	01
04180103	The COMMON\$MEM_FAIL_TEMPLATE template found in the esd is not supported by the Fault Manager. The bad template was discovered while trying to translate an esd into an eip. <ul style="list-style-type: none"> ■ Last Failure Parameter [0] contains the instance code value. ■ Last Failure Parameter [1] contains the template code value. ■ Last Failure Parameter [2] contains the template flags value. 	01
04190100	A NULL pointer was found for the target_ctx, or the target_ctx has an invalid type.	01
05010100	In recursive_nonconflict could not get enough memory for scanning the keyword tables for configuration name conflicts.	01
06010100	The DUART was unable to allocate enough memory to establish a connection to the CLI.	01
06020100	A port other than terminal port A was referred to by a set terminal characteristics command. This is illegal.	01
06030100	A DUP question or default question message type was passed to the DUART driver, but the pointer to the input area to receive the response to the question was NULL.	01
06040100	Attempted to detach unattached maintenance terminal.	01
06050100	Attempted output to unattached maintenance terminal.	01
06060100	Attempted input from output only maintenance terminal service.	01
06070100	The DUART was unable to allocate enough memory for its input buffers	01
06080000	Controller was forced to restart due to entry of a CNTRL-K character on the maintenance terminal.	00
07010100	All available slots in the FOC notify table are filled.	01
07020100	FOC\$CANCEL_NOTIFY() was called to disable notification for a rtn that did not have notification enabled.	01
07030100	Unable to start the Failover Control Timer before main loop.	01
07040100	Unable to restart the Failover Control Timer.	01
07050100	Unable to allocate flush buffer.	01
07060100	Unable to allocate active receive fcb.	01

Table 7-18 Last Failure Codes (Sheet 26 of 41)

Code	Description	Repair Action Code
07070100	The other controller killed this, but could not assert the kill line because nindy on or in debug. So it killed this now.	01
07080000	The other controller crashed, so this one must crash too.	00
07090100	A call to EXEC\$ALLOCATE_MEM_ZEROED failed to return memory when allocating VA Request Items.	01
08010101	A remote state change was received from the FOC thread that NVFOC does not recognize. <ul style="list-style-type: none"> ■ Last Failure Parameter[0] contains the unrecognized state value. 	01
08020100	No memory could be allocated for a NVFOC information packet.	01
08030101	Work received on the S_nvfoc_bque did not have a NVFOC work id. <ul style="list-style-type: none"> ■ Last Failure Parameter[0] contains the id type value that was received on the NVFOC work queue. 	01
08040101	Unknown work value received by the S_nvfoc_bque. <ul style="list-style-type: none"> ■ Last Failure Parameter[0] contains the unknown work value. 	01
08060100	A really write command was received when the NV memory was not locked.	01
08070100	A write to NV memory was received while not locked.	01
08080000	The other controller requested this controller to restart.	00
08090010	The other controller requested this controller to shutdown.	00
080A0000	The other controller requested this controller to selftest.	00
080B0100	Could not get enough memory to build a FCB to send to the remote routines on the other controller.	01
080C0100	Could not get enough memory for FCBs to receive information from the other controller.	01
080D0100	Could not get enough memory to build a FCB to reply to a request from the other controller.	01
080E0101	An out-of-range receiver ID was received by the NVFOC communication utility (master send to slave send ACK). <ul style="list-style-type: none"> ■ Last Failure Parameter[0] contains the bad id value. 	01
080F0101	An out-of-range receiver ID was received by the NVFOC communication utility (received by master). <ul style="list-style-type: none"> ■ Last Failure Parameter[0] contains the bad id value. 	01

Table 7-18 Last Failure Codes (Sheet 27 of 41)

Code	Description	Repair Action Code
08100101	A call to NVFOC\$TRANSACTION had a from field (id) that was out of range for the NVFOC communication utility. <ul style="list-style-type: none"> ■ Last Failure Parameter [0] contains the bad id value. 	01
08110101	NVFOC tried to defer more than one FOC send. <ul style="list-style-type: none"> ■ Last Failure Parameter[0] contains the master ID of the connection that had the multiple delays. 	01
08140100	Could not allocate memory to build a workblock to queue to the NVFOC thread.	01
08160100	A request to clear the remote configuration was received but the memory was not locked.	01
08170100	A request to read the next configuration was received but the memory was not locked.	01
08180100	Could not get enough memory for FLS FCBs to receive information from the other controller.	01
08190100	An unlock command was received when the NV memory was not locked.	01
081A0100	Unable to allocate memory for remote work.	01
081B0101	Bad remote work received on remote work queue. <ul style="list-style-type: none"> ■ Last Failure Parameter[0] contains the id type value that was received on the NVFOC remote work queue. 	01
081C0101	Bad member management work received. <ul style="list-style-type: none"> ■ Last Failure Parameter[0] contains the bad member management value that was detected. 	01
081D0000	In order to go into <i>mirrored</i> cache mode, the controllers must be restarted.	00
081E0000	Applies to <i>nonmirrored</i> .	
081F0000	An FLM\$INSUFFICIENT_RESOURCES error was returned from a FLM lock or unlock call.	00
08200000	Expected restart so the write_instance may recover from a configuration mismatch.	00
08210100	Unable to allocate memory to setup NVFOC lock/unlock notification routines.	01
09010100	Unable to acquire memory to initialize the FLM structures.	01
09640101	Work that was not FLM work was found on the FLM queue. Bad format is detected or the formatted string overflows the output buffer. <ul style="list-style-type: none"> ■ Last Failure Parameter [0] contains the work found. 	01
09650101	Work that was not FLM work was found on the FLM queue. <ul style="list-style-type: none"> ■ Last Failure Parameter [0] contains the structure found. 	01

Table 7-18 Last Failure Codes (Sheet 28 of 41)

Code	Description	Repair Action Code
09670101	Local FLM detected an invalid facility to act upon. ■ Last Failure Parameter [0] contains the facility found.	01
09680101	Remote FLM detected an error and requested the local controller to restart. ■ Last Failure Parameter [0] contains the reason for the request.	01
09C80101	Remote FLM detected an invalid facility to act upon. ■ Last Failure Parameter [0] contains the facility found.	01
09C90101 09CA0101	Remote FLM detected an invalid work type. ■ Last Failure Parameter [0] contains the work type found.	01
09CB0012	Remote FLM detected that the other controller has a facility lock manager at an incompatible revision level with this controller. ■ Last Failure Parameter [0] contains the controller's FLM revision. ■ Last Failure Parameter [1] contains the other controller's FLM revision.	00
0A020100	ILF\$CACHE_READY unable to allocate necessary DWDs.	01
0A030100	ILF\$CACHE_READY buffers_obtained > non-zero stack entry count.	01
0A040100	ILF\$CACHE_READY DWD overrun.	01
0A050100	ILF\$CACHE_READY DWD underrun.	01
0A060100	ILF\$CACHE_READY found buffer marked for other controller.	01
0A070100	CACHE\$FIND_LOG_BUFFERS returned continuation handle > 0.	01
0A080100	Not processing a bugcheck.	01
0A090100	No active DWD.	01
0A0A0100	Current entry pointer is not properly aligned.	01
0A0B0100	Next entry pointer is not properly aligned.	01
0A0E0100	Active DWD is not a DISK WRITE DWD as expected.	01
0A0F0100	New active DWD is not a DISK WRITE DWD as expected.	01
0A100100 0A120100 0A130100	Data buffer pointer is not properly aligned.	01
0A140100	New entry pointer is not properly aligned.	01
0A150100	New entry record type is out of range.	01

Table 7-18 Last Failure Codes (Sheet 29 of 41)

Code	Description	Repair Action Code
0A190102	ilf_depopulate_DWD_to_cache first page guard check failed. <ul style="list-style-type: none"> ■ Last Failure Parameter [0] contains the DWD address value. ■ Last Failure Parameter [1] contains the buffer address value. 	01
0A1C0102	ILF\$LOG_ENTRY page guard check failed.	01
0A1D0102	■ Last Failure Parameter [0] contains the DWD address value.	
0A1E0102	■ Last Failure Parameter [1] contains the buffer address value.	
0A1F0100	ilf_rebind_cache_buffs_to_DWDs found duplicate buffer for current DWD.	01
0A200101	Unknown bugcheck code passed to ilf_cache_interface_crash. <ul style="list-style-type: none"> ■ Last Failure Parameter [0] contains the unknown bugcheck code value. 	01
0A210100	ilf_rebind_cache_buffs_to_DWDs found buffer type not IDX_ILF.	01
0A220100	ilf_rebind_cache_buffs_to_DWDs found buffer DBD index too big.	01
0A240100	ilf_check_handle_array_edc found ihiea EDC bad.	01
0A250100	ilf_get_next_handle found no free ihiea entry.	01
0A260100	ilf_remove_handle could not find specified handle.	01
0A270100	ilf_depopulate_DWD_to_cache could not find handle for first buffer.	01
0A280100	ilf_depopulate_DWD_to_cache buffer handle does not match current handle.	01
0A290100	ilf_rebind_cache_buffs_to_DWDs could not find handle for DWD being rebound.	01
0A2B0100	ILF\$CACHE_READY cache manager did not return multiple of DWD DBDs worth of buffers.	01
0A2C0100	ilf_rebind_cache_buffs_to_DWDs page guard check failed.	01
0A2D0100	ilf_populate_DWD_from_cache buffer stack entry zero or not page aligned.	01
0A2E0100	ilf_populate_DWD_from_cache returned buffer type not IDX_ILF.	01
0A2F0100	ilf_rebind_cache_buffs_to_DWDs buffer stack entry not page aligned.	01
0A300100	ilf_depopulate_DWD_to_cache buffer stack entry zero or not page aligned.	01
0A310100	ilf_distribute_cache_DWDs active handle count not as expected.	01
0A320102	ILF\$LOG_ENTRY, page guard check failed. <ul style="list-style-type: none"> ■ Last Failure Parameter [0] contains the DWD address value. ■ Last Failure Parameter [1] contains the buffer address value. 	01
0A330100	ilf_output_error, message_keeper_array full.	01

Table 7-18 Last Failure Codes (Sheet 30 of 41)

Code	Description	Repair Action Code
0A340101	ilf_output_error, no memory for message display. <ul style="list-style-type: none"> ■ Last Failure Parameter [0] contains the message address value. 	01
0A360100	Duplicate entry found in ilf_populate_DWD_from_cache buffer stack.	01
0A370100	Duplicate entry found in ilf_rebind_cache_buffs_to_DWDs buffer stack.	01
0A380108	Next entry was partially loaded. <ul style="list-style-type: none"> ■ Last Failure Parameter [0] contains the next entry address. ■ Last Failure Parameter [1] contains the next entry record type. ■ Last Failure Parameter [2] contains the next entry TOD flag. ■ Last Failure Parameter [3] contains the next entry INT flag. ■ Last Failure Parameter [4] contains the next entry byte count. ■ Last Failure Parameter [5] contains the next entry tod ticks. ■ Last Failure Parameter [6] contains the next entry tod days. ■ Last Failure Parameter [7] contains the next entry data start. 	01
0B010010	Due to an operator request, the controllers non-volatile configuration information has been reset to its initial state.	00
0B020100	The controller has insufficient free memory to allocate a Configuration Manager work item needed to perform the requested configuration <i>reset</i> .	01
0B030100	Applies to <i>restore</i> .	
0B040100	The controller has insufficient free memory to allocate a Configuration Manager WWL work item needed to perform the requested World-Wide LUN ID change.	01
0B050100	More requests to WWL\$NOTIFY have been made than can be supported.	01
0B060100	A call to WWL\$UPDATE resulted in the need for another World-Wide LUN ID slot, and no free slots were available.	01
0B070100	The controller has insufficient free memory to allocate a Configuration Manager DNN work item needed to perform the requested Device Nickname change.	01
0B080100	More requests to DNN\$NOTIFY have been made than can be supported.	01
0B090100	A call to DNN\$UPDATE resulted in the need for another Device Nickname slot, and no free slots were available.	01
0B0A0100	Unable to find any unused partition group. With 127 available, we should be able to find at least one.	01

Table 7-18 Last Failure Codes (Sheet 31 of 41)

Code	Description	Repair Action Code
OB0B0100	Unable to find any unused partition group. With 128 available, we should be able to find at least one.	01
OB0C0100	Unable to allocate memory to use for communication with the DT manager.	01
OD000011	The EMU firmware returned a bad status when told to poweroff. ■ Last Failure Parameter [0] contains the value of the bad status.	00
OE000100	VA\$ENABLE_NOTIFICATION failed with insufficient resources at controller initialization time.	01
OE010102	An invalid status was returned from CACHE\$LOCK_READ during a remote copy. ■ Last Failure Parameter [0] contains the DD address. ■ Last Failure Parameter [1] contains the invalid status.	01
OE020100	Unable to allocate memory for the Fault Management Event Information Packet used in generating error logs to the host.	01
OE030100	Unable to allocate memory for a Failover Control Block.	01
OE040100		
OE050100		
OE060100		
OE096980	This controller has detected a failed link during the heartbeat to a remote target. The other controller has a good link to the remote target. In order to resume operations to that remote target, this controller is restarted to failover the initiator unit to the other controller.	69
OE0A6980	A remote copy write has failed all recovery attempts on this controller. As part of further error recovery, this controller is restarted, to force the initiator unit over to the other controller so the remote copy can be retried.	69
OE0B6980	This controller has detected a failed link upon dual controllers restarting. The other controller has a good link to the remote target. In order to resume operations to that remote target, this controller is restarted to failover the initiator unit to the other controller.	69
OE0C0101	Unrecognized request to perform WHL operation on other controller. ■ Last Failure Parameter [0] contains operation request.	01
OE0D0101	Unrecognized WHL operation ID received from other controller. ■ Last Failure Parameter [0] contains operation ID.	01
OE0E0101	An illegal failover request was given to the Write History Log request handler. ■ Last Failure Parameter [0] contains failover request.	01

Table 7-18 Last Failure Codes (Sheet 32 of 41)

Code	Description	Repair Action Code
0E0F0101	An illegal failover response was given to the Write History Log response handler. ■ Last Failure Parameter [0] contains failover response.	01
0E100100	The Write History Log failover control had a bad send count.	01
0E110100	Unable to allocate memory for WHL DBs.	01
0E120100	Unable to allocate memory for WHL HTBs.	01
0E130100	Unable to allocate memory for WHL ESDs.	01
0E140100	Unable to allocate memory for WHL DDs.	01
0E150101	Unable to allocate memory for WHL metadata. ■ Last Failure Parameter [0] contains response failure code.	01
0E160100	An illegal WHL lock state was detected.	01
0E170101	An invalid sense key was detected during WHL processing. ■ Last Failure Parameter [0] contains unexpected sense key.	01
0E180100	Call to VA\$ENABLE_NOTIFICATION() failed due to INSUFFICIENT_RESOURCES.	01
12000103	Two values found <i>not equal</i> . ■ Last Failure Parameter [0] contains the ASSUME instance address. ■ Last Failure Parameter [1] contains the first variable value. ■ Last Failure Parameter [2] contains the second variable value.	01
12010103	Applies to <i>equal</i> .	
12020103	First value found <i>bigger or equal</i> . ■ Last Failure Parameter [0] contains the ASSUME instance address. ■ Last Failure Parameter [1] contains the first variable value. ■ Last Failure Parameter [2] contains the second variable value.	01
12030103	Applies to <i>bigger</i> .	
12040103	Applies to <i>smaller or equal</i> .	
12050103	Applies to <i>smaller</i> .	
12060102	vsi_ptr->no_interlock not set. ■ Last Failure Parameter [0] contains the ASSUME instance address. ■ Last Failure Parameter [1] contains nv_index value.	01

Table 7-18 Last Failure Codes (Sheet 33 of 41)

Code	Description	Repair Action Code
12070102	vsi_ptr->allocated_this not set. <ul style="list-style-type: none"> ■ Last Failure Parameter [0] contains the ASSUME instance address. ■ Last Failure Parameter [1] contains nv_index value. 	01
12080102	vsi_ptr->cs_interlocked not set. <ul style="list-style-type: none"> ■ Last Failure Parameter [0] contains the ASSUME instance address. ■ Last Failure Parameter [1] contains nv_index value. 	01
12090102	Unhandled switch case. <ul style="list-style-type: none"> ■ Last Failure Parameter [0] contains the ASSUME instance address. ■ Last Failure Parameter [1] contains nv_index value. 	01
120A0103	WARP expand point value does not match blocks. <ul style="list-style-type: none"> ■ Last Failure Parameter [0] contains the warp address. ■ Last Failure Parameter [1] contains the warp expand point value. ■ Last Failure Parameter [2] contains the warp blocks value. 	01
120B2380	Forced restart of the controller upon a cache battery failure. This is only done when under conditions which require the restart for error recovery.	23
120C0101	Found invalid UPS Descriptor state. <ul style="list-style-type: none"> ■ Last Failure Parameter[0] contains UPS Descriptor state. 	01
120D0100	Initialization code was unable to allocate enough memory to set up the send data descriptors for local buffer transfers.	01
20010100	The action for work on the CLI queue should be CLI_CONNECT, CLI_COMMAND_IN or CLI_PROMPT. If it isn't one of these three, this bugcheck will result.	01
20020100	The FAO returned a non-successful response. This will only happen if a bad format is detected or the formatted string overflows the output buffer.	01
20030100	The type of work received on the CLI work queue wasn't of type CLI.	01
20060100	A work item of an unknown type was placed on the CLI's SCSI Virtual Terminal thread's work queue by the CLI.	01
20080000	This controller requested this controller to <i>restart</i> .	00
20090010	Applies to <i>shutdown</i> .	
200A0000	Applies to <i>selftest</i> .	
200B0100	Could not get enough memory for FCBs to receive information from the other controller.	01

Table 7-18 Last Failure Codes (Sheet 34 of 41)

Code	Description	Repair Action Code
200D0101	After many calls to DSS\$PORT_BLOCKED, we never got a FALSE status back (which signals that nothing is blocked). ■ Last Failure Parameter[0] contains the port number (1 - n) that we were waiting on to be unblocked.	01
200E0101	While traversing the structure of a unit, a config_info node was discovered with an unrecognized structure type. ■ Last Failure Parameter[0] contains the structure type number that was unrecognized.	01
200F0101	A config_info node was discovered with an unrecognized structure type. ■ Last Failure Parameter[0] contains the structure type number that was unrecognized.	01
20100101	A config_node of type VA_MA_DEVICE had an unrecognized SCSI device type. ■ Last Failure Parameter[0] contains the SCSI device type number that was unrecognized.	01
20110100	An attempt to allocate memory so the CLI prompt messages could be deleted failed.	01
20120101	While traversing the structure of a unit, a config_info node was discovered with an unrecognized structure type. ■ Last Failure Parameter[0] contains the structure type number that was unrecognized.	01
20130101	While traversing the structure of a unit, the device was of an unrecognized type. ■ Last Failure Parameter[0] contains the SCSI device type that was unrecognized.	01
20160000	In order to go into mirrored cache mode, the controllers must be restarted.	00
20160100	Unable to allocate resources needed for the CLI local program.	01
20170000	In order to go into no mirrored cache mode, the controllers must be restarted.	00
20190010	A cache state of a unit remains WRITE_CACHE_UNWRITTEN_DATA. The unit is not ONLINE, thus this state would only be valid for a very short period of time.	00
201A0100	An attempt to allocate memory so a CLI prompt message could be reformatted failed.	01
201B0100	Insufficient resources to get memory to <i>lock</i> CLI.	01
201C0100	Applies to <i>unlock</i> .	
20200100	CL\$ALLOCATE_STRUCT() could not obtain memory for a new nvfoc_rw_remote_nvmem structure.	01
20220020	This controller requested this subsystem to poweroff.	00
20260000	With "set failover copy=other", the controller which is having the configuration copied to will automatically be restarted via this bugcheck.	00

Table 7–18 Last Failure Codes (Sheet 35 of 41)

Code	Description	Repair Action Code
20640000	Nindy was turned <i>on</i> .	00
20650000	Applies to <i>off</i> .	
20692010	To enter dual-redundant mode, both controllers must be of the same type.	20
206A0000	Controller restart forced by DEBUG CRASH REBOOT command.	00
206B0010	Applies to DEBUG CRASH NOREBOOT.	
206C0020	Controller was forced to restart in order for new controller code image to take effect.	00
206D0000	Controller code load was not completed because the controller could not rundown all units.	00
206E0000	A restart of both controllers is required when entering multibus failover and the last failover mode of the source controller was transparent, or when entering transparent failover and the last failover mode of the source controller was multibus.	00
43000100	Encountered an unexpected structure type on hp_work_q.	01
43030100	Unable to allocate the necessary number of large Sense Data buckets in HPP_init().	01
43100100	Encountered a NULL completion routine pointer in a DD.	01
43130100	Could not allocate a large sense bucket.	01
43160100	A sense data bucket of unknown type (neither LARGE or SMALL) was passed to deallocate_SDB().	01
43170100	Call to VA\$ENABLE_NOTIFICATION() failed due to INSUFFICIENT_RESOURCES.	01
43190100	Unable to allocate necessary memory in HPP_int().	01
431A0100	Unable to allocate necessary timer memory in HPP_int().	01
43210101	HPP detected unknown error indicated by HPT. <ul style="list-style-type: none"> ■ Last Failure Parameter [0] contains the error value. 	01
43220100	Unable to obtain Free CSR in HPP().	01
43230101	During processing to maintain consistency of the data for Persistent Reserve SCSI commands, an internal inconsistency was detected. <ul style="list-style-type: none"> ■ Last Failure Parameter [0] contains a code defining the precise nature of the inconsistency. 	01
44640100	Not enough abort requests in the system.	01
44650100	Exceeded the number of SEST abort retries.	01

Table 7-18 Last Failure Codes (Sheet 36 of 41)

Code	Description	Repair Action Code
44660100	Unable to allocate enough <i>abort requests</i> for Fibre Channel Host Port Transport software layer.	01
44670100	Applies to <i>command HTBs</i> .	
44680100	Applies to <i>FC HTBs</i> .	
44690100	Applies to <i>work requests</i> .	
446A0100	Applies to <i>HTBs</i> .	
446B0100	Applies to <i>TIS structures</i> .	
446C0100	Applies to <i>MFSs</i> .	
446D0100	Applies to <i>TACHYON headers</i> .	
446E0100	Applies to <i>EDB structures</i> .	
446F0100	Applies to <i>LSFS structures</i> .	
44700100	Unable to allocate enough TPS structures for Fibre Channel Host Port Transport software layer.	01
44720101	An illegal status was returned to the FLOGI command error handler. <ul style="list-style-type: none"> ■ Last Failure Parameter [0] contains error value. 	01
44730101	An illegal completion message was returned by the TACHYON to I960. <ul style="list-style-type: none"> ■ Last Failure Parameter [0] contains the completion message type. 	01
44740101	The Host Port Transport process handler received an illegal timer. <ul style="list-style-type: none"> ■ Last Failure Parameter [0] contains the timer pointer. type. 	01
44750100	The Host Port Transport work handler received an illegal work request.	01
44760100	The Host Port Transport ran out of work requests.	01
44770102	An illegal script return value was received by the Host Port Transport init script handler. <ul style="list-style-type: none"> ■ Last Failure Parameter [0] contains the init function. ■ Last Failure Parameter [1] contains return value. The Host Port Transport ran out of work requests.	01
44780102	An illegal script return value was received by the Host Port Transport send script handler. <ul style="list-style-type: none"> ■ Last Failure Parameter [0] contains the send function. ■ Last Failure Parameter [1] contains return value. The Host Port Transport ran out of work requests.	01

Table 7–18 Last Failure Codes (Sheet 37 of 41)

Code	Description	Repair Action Code
44790102	An illegal script return value was received by the Host Port Transport response script handler. <ul style="list-style-type: none"> ■ Last Failure Parameter [0] contains the rsp function. ■ Last Failure Parameter [1] contains return value. The Host Port Transport ran out of work requests.	01
447A0102	An illegal script return value was received by the Host Port Transport error script handler. <ul style="list-style-type: none"> ■ Last Failure Parameter [0] contains the error function. ■ Last Failure Parameter [1] contains return value. The Host Port Transport ran out of work requests.	01
447B0100	The Host Port Transport response script handler received a response before a command was sent.	01
447C0101	Unhandled command HTB status. <ul style="list-style-type: none"> ■ Last Failure Parameter [0] contains the status value. The Host Port Transport ran out of work requests.	01
447D0100	The Host Port Transport ran out of command HTBs.	01
44800101	An illegal status was returned to the <i>name service</i> command error handler. <ul style="list-style-type: none"> ■ Last Failure Parameter [0] contains error value. 	01
44810101	<ul style="list-style-type: none"> ■ Applies to <i>PLOGI</i>. 	
44820101	An illegal abort type was given to the Host Port Transport abort handler. <ul style="list-style-type: none"> ■ Last Failure Parameter [0] contains abort type. 	01
44830101	An illegal failover request was given to the Host Port Transport request handler. <ul style="list-style-type: none"> ■ Last Failure Parameter [0] contains failover request. 	01
44840101	An illegal failover response was given to the Host Port Transport failover response handler. <ul style="list-style-type: none"> ■ Last Failure Parameter [0] contains failover response. 	01
44850100	The Host Port Transport failover control had a bad send count.	01
44860100	Unable to allocate enough ESD structures for Fibre Channel Host Port Transport software layer.	01
44870101	An illegal abort type was given to the Host Port Transport abort handler. <ul style="list-style-type: none"> ■ Last Failure Parameter [0] contains abort type. 	01

Table 7-18 Last Failure Codes (Sheet 38 of 41)

Code	Description	Repair Action Code
44892091	Host Port Hardware diagnostic field at system initialization. ■ Last Failure Parameter [0] contains failed port number.	20
448B0100	Host Port Transport software layer unable to allocate work item for updating NV memory during LOGI.	01
448C0100	Host Port Transport software layer unable to allocate work item for LOGI completion routine.	01
448D0100	Host port transport software layer ran out of temporary HCBs.	01
448E0100	Host Port Transport software layer unable to allocate memory for quick FC responses.	01
448F0100	Host Port Transport software layer unable to allocate memory for quick responses.	01
44900100	Host Port Transport software layer unable to allocate memory for HCBs.	01
44910100	Host Port Transport software layer unable to allocate memory for HTB TACHYON header.	01
44920101	An invalid work item was detected on abort pending work queue. ■ Last Failure Parameter [0] contains invalid work type.	01
44930100	Unable to allocate enough Peer to Peer Remote Copy TACHYON headers for Fibre Channel Host Port Transport software layer.	01
44940100	Host Port Transport software layer detected an error during buffer-to-buffer credit check.	01
44950100	Host Port Transport software layer unable to acquire an FC quick response resource.	01
44960101	An invalid work item was detected on work pending queue. ■ Last Failure Parameter [0] contains invalid work type.	01
44970100	Host Port Transport software layer unable to access TACHYON register.	01
449A0101	An invalid work item was detected on abort pending work queue. ■ Last Failure Parameter [0] contains work type.	01
64000100	Insufficient buffer memory to allocate data structures needed to propagate SCSI Mode Select changes to other controller.	01
64010100	During an initialization of LUN specific mode pages, an unexpected device type was encountered.	01

Table 7–18 Last Failure Codes (Sheet 39 of 41)

Code	Description	Repair Action Code
64030104	A DD is already in use by an RCV DIAG command—cannot get two RCV_DIAGs without sending the data for the first. <ul style="list-style-type: none"> ■ Last Failure Parameter [0] contains DD_PTR. ■ Last Failure Parameter [1] contains blocking HTB_PTR. ■ Last Failure Parameter [2] contains HTB_PTR flags. ■ Last Failure Parameter [3] contains this HTB_PTR. 	01
64040100	An attempt to allocate a free VAR failed.	01
80010100	An HTB was not available to issue an I/O when it should have been.	01
80030100	DILX tried to release a facility that wasn't reserved by DILX.	01
80040100	DILX tried to change the unit state from MAINTENANCE_MODE to NORMAL but was rejected because of insufficient resources.	01
80050100	DILX tried to change the usb unit state from MAINTENANCE_MODE to NORMAL but DILX never received notification of a successful state change.	01
80060100	DILX tried to switch the unit state from MAINTENANCE_MODE to NORMAL but was not successful.	01
80070100	DILX aborted all cmds via va\$d_abort() but the HTBS haven't been returned.	01
80090100	DILX received an end msg which corresponds to an op code not supported by DILX.	01
800A0100	DILX was not able to restart his timer.	01
800B0100	DILX tried to issue an I/O for an opcode not supported.	01
800C0100	DILX tried to issue a oneshot I/O for an opcode not supported.	01
800D0100	A DILX device control block contains an unsupported unit_state.	01
800F0100	A DILX cmd completed with a sense key that DILX does not support.	01
80100100	DILX could not compare buffers because no memory was available from EXEC\$ALLOCATE_MEM_ZEROED.	01
80110100	While DILX was deallocating his deferred error buffers, at least one could not be found.	01
80120100	DILX expected an Event Information Packet (EIP) to be on the receive EIP queue but no EIPs were there.	01
80130100	DILX was asked to fill a data buffer with an unsupported data pattern.	01
80140100	DILX could not process an unsupported answer in dx\$reuse_params().	01
80150100	A deferred error was received with an unsupported template.	01

Table 7-18 Last Failure Codes (Sheet 40 of 41)

Code	Description	Repair Action Code
83020100	An unsupported message type or terminal request was received by the CONFIG virtual terminal code from the CLI.	01
83030100	Not all alter_device requests from the CONFIG utility completed within the timeout interval.	01
84010100	An unsupported message type or terminal request was received by the CLONE virtual terminal code from the CLI.	01
85010100	HSUTIL tried to release a facility that wasn't reserved by HSUTIL.	01
85020100	HSUTIL tried to change the unit state from MAINTENANCE_MODE to NORMAL but was rejected because of insufficient resources.	01
85030100	HSUTIL tried to change the usb unit state from MAINTENANCE_MODE to NORMAL but HSUTIL never received notification of a successful state change.	01
85040100	HSUTIL tried to switch the unit state from MAINTENANCE_MODE to NORMAL but was not successful.	01
86000020	Controller was forced to restart in order for new code load or patch to take effect.	00
86010010	The controller code load function is about to update the program card. This requires controller activity to cease. This code is used to inform the other controller this controller will stop responding to inter-controller communications during card update. An automatic restart of the controller at the end of the program card update will cause normal controller activity to resume.	00
86020011	The EMU firmware returned a bad status when told to prepare for a code load. <ul style="list-style-type: none"> ■ Last Failure Parameter [0] contains the value of the bad status. 	00
8A040080	New cache module failed diagnostics. The controller has been reset to clear the error.	00
8A050080	Could not initialize new cache module. The controller has been reset to clear the error.	00

Table 7–18 Last Failure Codes (Sheet 41 of 41)

Code	Description	Repair Action Code
8B000186	<p>An single bit error was found by software scrubbing.</p> <ul style="list-style-type: none"> ■ Last Failure Parameter [0] contains the address of the first single bit ecc error found. ■ Last Failure Parameter [1] contains the count of single bit ecc errors found in the same region below this address. ■ Last Failure Parameter [2] contains the lower 32-bits of the actual data read at the Parameter [0] address. ■ Last Failure Parameter [3] contains the higher 32-bits of the actual data read at the Parameter [0] address. ■ Last Failure Parameter [4] contains the lower 32-bits of the expected data at the Parameter [0] address. ■ Last Failure Parameter [5] contains the higher 32-bits of the expected data at the Parameter [0] address. 	01

Recommended Repair Action Codes

Recommended Repair Action Codes are embedded in Instance and Last Failure codes. See “Instance Codes” on page 7-20 and “Last Failure Codes” on page 7-45 for a more detailed description of the relationship between these codes.

Table 7-19 contains the repair action codes assigned to each significant event in the system.

Table 7-19 Recommended Repair Action Codes (Sheet 1 of 6)

Code	Description
00	No action necessary.
01	An unrecoverable hardware detected fault occurred or an unrecoverable software inconsistency was detected. Proceed with controller support avenues.
03	Follow the recommended repair action contained as indicated in the Last Failure Code.
04	Two possible problem sources are indicated: <ul style="list-style-type: none"> ■ In the case of a shelf with dual power supplies, one of the power supplies has failed. Follow repair action 07 for the power supply with the Power LED out. ■ One of the shelf blowers has failed. Follow repair action 06.
05	Four possible problem sources are indicated: <ul style="list-style-type: none"> ■ Total power supply failure on a shelf. Follow repair action 09. ■ A device inserted into a shelf that has a broken internal SBB connector. Follow repair action 0A. ■ A standalone device is connected to the controller with an incorrect cable. Follow repair action 08. ■ A controller hardware failure. Follow repair action 20.
06	Determine which blower has failed and replace it.
07	Replace power supply.
08	Replace the cable. Refer to the specific device documentation.
09	Determine power failure cause.
0A	Determine which SBB has a failed connector and replace it.
0B	The other controller in a dual-redundant configuration has been reset with the “Kill” line by the controller that reported the event. To restart the “Killed” controller enter the CLI command <code>RESTART OTHER</code> on the “Surviving” controller and then depress the (//) RESET button on the “Killed” controller. If the other controller is repeatedly being “Killed” for the same or a similar reason, follow repair action 20.

Table 7–19 Recommended Repair Action Codes (Sheet 2 of 6)

Code	Description
0C	<p>Both controllers in a dual-redundant configuration are attempting to use the same SCSI ID (either 6 or 7 as indicated in the event report).</p> <p>The other controller of the dual-redundant pair has been reset with the “Kill” line by the controller that reported the event. Two possible problem sources are indicated:</p> <ul style="list-style-type: none"> ■ A controller hardware failure. ■ A controller backplane failure. <p>First, follow repair action 20 for the “Killed” controller. If the problem persists follow repair action 20 for the “Surviving” controller. If the problem still persists replace the controller backplane.</p>
0D	The Environmental Monitor Unit has detected an elevated temperature condition. Check the shelf and its components for the cause of the fault.
0E	The Environmental Monitor Unit has detected an external air-sense fault. Check components outside of the shelf for the cause of the fault.
0F	An environmental fault previously detected by the Environmental Monitor Unit is now fixed. This event report is notification that the repair was successful.
10	Restore on-disk configuration information to original state.
11	<p>The Uninterruptable Power Supply (UPS) signaled a 2 minute warning (TMW) before it signaled AC line failure. UPS signals will be ignored until this condition clears.</p> <ul style="list-style-type: none"> ■ Repair or replace the UPS. ■ The communication cable between the UPS and PVA is missing or damaged. Replace the cable.
20	Replace the controller module.
22	Replace the indicated cache module or the appropriate memory DIMMs on the indicated cache module.
23	Replace the indicated write cache battery. CAUTION: BATTERY REPLACEMENT MAY CAUSE INJURY.
24	<p>Check for the following invalid write cache configurations:</p> <ul style="list-style-type: none"> ■ If the wrong write cache module is installed, replace with the matching module or clear the invalid cache error via the CLI. Refer to <i>HSG80 Array Controller ACS Version 8.5 CLI Reference Guide</i> for more information. ■ If the write cache module is missing, reseal cache if it is actually present, or add the missing cache module, or clear the invalid cache error via the CLI. Refer to <i>HSG80 Array Controller ACS Version 8.5 CLI Reference Guide</i> for more details. ■ If in a dual-redundant configuration and one of the write cache modules is missing, match write cache boards with both controllers.
25	An unrecoverable Memory System failure occurred. Upon restart the controller will generate one or more Memory System Failure Event Sense Data Responses; follow the repair action(s) contained therein.

Table 7-19 Recommended Repair Action Codes (Sheet 3 of 6)

Code	Description
37	The Memory System Failure translator could not determine the failure cause. Follow repair action 01.
38	Replace the indicated cache memory DIMM.
39	Check that the cache memory DIMMs are properly configured.
3A	This error applies to this controller's mirrored cache. Since the mirrored cache is physically located on the other controller's cache module, replace the other controller's cache module, or the appropriate memory DIMMs on the other controller's cache module.
3C	This error applies to this controller's mirrored cache. Since the mirrored cache is physically located on the other controller's cache module, replace the indicated cache memory DIMM on the other controller's cache module.
3D	<p>Either the primary cache or the mirrored cache has inconsistent data. Check for the following conditions to determine appropriate means to restore mirrored copies.</p> <ul style="list-style-type: none"> ■ If the mirrored cache is reported as inconsistent and a previous FRU Utility warmswap of the mirrored cache module was unsuccessful, retry the procedure via the FRU Utility, by removing the module and re-inserting the same or a new module. ■ Otherwise, enter the CLI command SHUTDOWN THIS to clear the inconsistency upon reboot.
3E	Replace the indicated cache module.
3F	No action necessary, cache diagnostics will determine whether the indicated cache module is faulty.
40	If the Sense Data FRU field is non-zero, follow repair action 41. Otherwise, replace the appropriate FRU associated with the device's SCSI interface or the entire device.
41	Consult the device's maintenance manual for guidance on replacing the indicated device FRU.
43	Update the configuration data to correct the problem.
44	Replace the SCSI cable for the failing SCSI bus. If the problem persists, replace the controller backplane, drive backplane, or controller module.
45	Interpreting the device supplied Sense Data is beyond the scope of the controller's software. See the device's service manual to determine the appropriate repair action, if any.
50	<p>The RAIDset is inoperative for one of the following reasons:</p> <ul style="list-style-type: none"> ■ More than one member malfunctioned. Perform repair action 55. ■ More than one member is missing. Perform repair action 58. ■ Before reconstruction of a previously replaced member completes another member becomes missing or malfunctions. Perform repair action 59. ■ The members have been moved around and the consistency checks show mismatched members. Perform repair action 58.

Table 7-19 Recommended Repair Action Codes (Sheet 4 of 6)

Code	Description
51	<p>The mirrorset is inoperative for one of the following reasons:</p> <ul style="list-style-type: none"> ■ The last NORMAL member has malfunctioned. Perform repair actions 55 and 59. ■ The last NORMAL member is missing. Perform repair action 58. ■ The members have been moved around and the consistency checks show mismatched members. Perform repair action 58.
52	<p>The indicated StorageSet member was removed for one of the following reasons:</p> <ul style="list-style-type: none"> ■ The member malfunctioned. Perform repair action 56. ■ By operator command. Perform repair action 57.
53	<p>The STORAGESET may be in a state that prevents the adding of a replacement member, check the state of the STORAGESET and its associated UNIT and resolve the problems found before adding the replacement member.</p>
54	<p>The device may be in a state that prevents adding it as a replacement member or may not be large enough for the STORAGESET. Use another device for the ADD action and perform repair action 57 for the device that failed to be added.</p>
55	<p>Perform the repair actions indicated in any and all event reports found for the devices that are members of the STORAGESET.</p>
56	<p>Perform the repair actions indicated in any and all event reports found for the member device that was removed from the STORAGESET. Then perform repair action 57.</p>
57	<p>Delete the device from the FAILEDSET and redeploy, perhaps by adding it to the SPARESET so it will be available to be used to replace another failing device.</p>
58	<p>Install the physical devices that are members of the STORAGESET in the proper Port, Target, and LUN locations.</p>
59	<p>Delete the STORAGESET, recreate it with the appropriate ADD, INITIALIZE, and ADD UNIT commands and reload its contents from backup storage.</p>
5A	<p>Restore the MIRRORSET data from backup storage.</p>
5B	<p>The mirrorset is inoperative due to a disaster tolerance failsafe locked condition, as a result of the loss of all local or remote NORMAL/NORMALIZING members while ERROR_MODE=FAILSAFE was enabled. To clear the failsafe locked condition, enter the CLI command SET unit-number ERROR_MODE=NORMAL.</p>
5C	<p>The mirrorset has at least one local NORMAL/NORMALIZING member and one remote NORMAL/NORMALIZING member. Failsafe error mode can now be enabled by entering the CLI command SET unit-number ERROR_MODE=FAILSAFE.</p>
5D	<p>The last member of the SPARESET has been removed. Add new drives to the SPARESET.</p>

Table 7-19 Recommended Repair Action Codes (Sheet 5 of 6)

Code	Description
69	An unrecoverable fault occurred at the host port. There may be more than one entity attempting to use the same SCSI ID, or some other bus configuration error, such as improper termination, may exist. If no host bus configuration problems are found, follow repair action 01.
80	An EMU fault has occurred.
81	The EMU reported terminator power out of range. Replace the indicated I/O module(s).
83	An EMU has become unavailable. <ul style="list-style-type: none"> ■ This EMU Unit (and associated cabinet) may have been removed from the subsystem; no action is required. ■ The cabinet has lost power; restore power to the cabinet. ■ The EMU-to-EMU communications bus cable has been disconnected or broken; replace or reconnect the cable to reestablish communications. ■ The specified EMU is broken; replace the EMU module. ■ The EMU in cabinet 0 is broken; replace the EMU module.
88	The remote copy set has an online initiator unit and at least one remote NORMAL/NORMALIZING target member. Failsafe error mode can now be enabled by entering the CLI command SET rc-set-name ERROR_MODE=FAILSAFE.
89	The remote copy set is inoperative due to a disaster tolerance failsafe locked condition, as a result of the loss of the local initiator unit or remote NORMAL/NORMALIZING target members while ERROR_MODE=FAILSAFE was enabled. To clear the failsafe locked condition, enter the CLI command SET rc-set-name ERROR_MODE=NORMAL.
8A	The indicated remote copy set target member was removed for one of the following reasons: <ul style="list-style-type: none"> ■ By operator command. ■ The member malfunctioned. Perform the repair actions indicated in any and all event reports found for that target member.
8B	Unable to communicate to the target member of the remote copy set for one of the following reasons: <ul style="list-style-type: none"> ■ The target malfunctioned. Perform the repair actions indicated in any and all event reports found for that target unit. ■ The target controller malfunctioned. Perform the repair actions indicated in any and all event reports found for that target controller. ■ Malfunction that occurred in the Fibre Channel fabric between the peer controllers.
8C	Unable to communicate to an initiator unit of the remote copy set because the unit malfunctioned. Perform the repair actions indicated in any and all event reports found for that initiator unit.

Table 7-19 Recommended Repair Action Codes (Sheet 6 of 6)

Code	Description
8D	It is not safe to present the WWLID to the host because a site failover may have taken place, but cannot confirm with the remote controller. Perform one of the following repair actions: <ul style="list-style-type: none"> ■ Follow repair action 8B. ■ If a site failover took place, and you don't plan to perform a future site failback, then delete the remote copy set on this controller.
8E	It is not safe to present the WWLID to the host because a site failover has taken place. Perform one of the following repair actions: <ul style="list-style-type: none"> ■ Perform a site failback. ■ Delete the remote copy set on this controller.
8F	Unable to communicate to a log unit because the unit malfunctioned. Perform the repair actions indicated in any and all event reports found for that log unit.

Component Identifier Codes

Component Identifier Codes are embedded in Instance and Last Failure codes. See “Instance Codes” on page 7-20 and “Last Failure Codes” on page 7-45 for a more detailed description of the relationship between these codes.

Table 7-20 lists the component identifier codes.

Table 7-20 Component Identifier Codes

Code	Description
01	Executive Services
02	Value Added Services
03	Device Services
04	Fault Manager
05	Common Library Routines
06	Dual Universal Asynchronous Receiver/Transmitter Services
07	Failover Control
08	Nonvolatile Parameter Memory Failover Control
09	Facility Lock Manager
0A	Integrated Logging Facility

Table 7-20 Component Identifier Codes (Continued)

Code	Description
0B	Configuration Manager Process
0C	Memory Controller Event Analyzer
0D	Poweroff Process
0E	Data Replication Manager Services (ACS V8.5P only)
12	Value Added Services (extended)
20	Command Line Interpreter (CLI)
43	Host Port Protocol Layer
44	Host Port Transport Layer
64	SCSI Host Value Added Services
80	Disk Inline Exercise (DILX)
82	Subsystem Built-In Self Tests (BIST)
83	Device Configuration Utilities (CONFIG)
84	Clone Unit Utility (CLONE)
85	Format and Device Code Load Utility (HSUTIL)
86	Code Load/Code Patch Utility (CLCP)
8A	Field Replacement Utility (FRUTIL)
8B	Periodic Diagnostics (PDIAG)

Appendix A

Array Controller Specifications

This appendix contains physical, electrical, and environmental specifications for enclosures that use the HSG80 array controller.

Physical and Electrical Specifications for the HSG80 Array Controller and Cache Modules

Table A-1 lists the physical and electrical specifications for the controller and cache modules. Voltage measurements in Table A-1 are nominal measurements (at +5 and +12 VDC) without tolerances.

Hardware	Length	Width	Power	Current at +5 VDC	Current at +12 VDC
HSG80 Array Controller module	305 mm (12 in)	241 mm (9.5 in)	23.27 W	6.04 A	
Write-back Cache, 512 MB	138 mm (5.5 in)	241 mm (9.5 in)	8.52 W		Cache running diagnostics and fully charged battery (400 mA)
			10.5 W		Cache running and battery charging (880 mA)

Environmental Specifications

The HSG80 array controller is intended for installation in a Class A environment.

The operating environmental specifications are listed in Table A-2 and the nonoperating environmental specifications are listed in Table A-3. These specifications are the same as for all *Compaq* storage devices.

Table A-2 Operating Environmental Specifications

Condition	Specification
Ambient temperature	+10 °C to +35 °C (+50 °F to +95 °F) Derate for altitude 0.5 °C per 300 m to 3000 m (1 °F per 1000 ft to 10,000 ft)
Relative humidity	10% to 90% at a maximum wet bulb temperature of 28 °C (82 °F)
Air quality	No to exceed a maximum of 500,000 particles, 0.5 micron or larger, per cubic foot of air

Table A-3 Nonoperating Environmental Specifications

Condition	Specification
Storage (Up to 1 Year)	
Ambient temperature	-20 °C to +60 °C (-4 °F to +140 °F) up to 3000 m (10,000 ft)
Relative humidity	10% to 95% at a maximum wet bulb temperature of 29 °C (84 °F)
Shipping (Up to 72 Hours)	
Ambient temperature	-40 °C to +60 °C (-40 °F to +140 °F) up to 9100 m (30,000 ft)
Relative humidity	10% to 90% at a maximum wet bulb temperature of 30 °C (86 °F)

Glossary

This glossary defines terms pertaining to the HSG80 Fibre Channel array controller. It is not a comprehensive glossary of computer terms.

8B/10B	A type of byte encoding and decoding to reduce errors in data transmission patented by the IBM Corporation. This process of encoding and decoding data for transmission has been adopted by ANSI.
ACS	<i>See</i> array controller software.
adapter	A device that converts the protocol and hardware interface of one bus type into another without changing the function of the bus.
AL_PA	<i>See</i> arbitrated loop physical address.
alias address	An AL_PA value recognized by an Arbitrated Loop port in addition to its assigned AL_PA.
ANSI	American National Standards Institute. An organization who develops standards used voluntarily by many manufacturers within the USA. ANSI is not a government agency.
arbitrate	A process of selecting one L_Port from a collection of several ports that request use of the arbitrated loop concurrently.
arbitrated loop	A loop type of topology where two or more ports can be interconnected, but only two ports at a time can communicate.

arbitrated loop physical address	Abbreviated AL_PA. A one-byte value used to identify a port in an Arbitrated Loop topology. The AL_PA value corresponds to bits 7:0 of the 24-bit Native Address Identifier.
array controller	<i>See</i> controller.
array controller software	Abbreviated ACS. Software contained on a removable ROM program card that provides the operating system for the array controller.
association set	<p>A group of remote copy sets that share selectable attributes for logging and failover. Members of an association set transition to the same state simultaneously. For example, if one association set member assumes the failsafe locked condition, then other members of the association set also assume the failsafe locked condition.</p> <p>An association set can also be used to share a log between a group of remote copy set members that require efficient use of the log space.</p> <p><i>See also</i> remote copy set.</p>
asynchronous	<p>Pertaining to events that are scheduled as the result of a signal asking for the event; pertaining to that which is without any specified time relation.</p> <p><i>See also</i> synchronous.</p>
autospare	A controller feature that automatically replaces a failed disk drive. To aid the controller in automatically replacing failed disk drives, you can enable the AUTOSPARE switch for the failedset causing physically replaced disk drives to be automatically placed into the spareset. Also called “autonewspare.”
backplane	The electronic printed circuit board into which you plug subsystem devices—for example, the SBB or power supply.
bad block	A data block that contains a physical defect.
bad block replacement	Abbreviated BBR. A replacement routine that substitutes defect-free disk blocks for those found to have defects. This process takes place in the controller, transparent to the host.
BBR	<i>See</i> bad block replacement.
BIST	<i>See</i> built-in self-test.
bit	A single binary digit having a value of either 0 or 1. A bit is the smallest unit of data a computer can process.

block	Also called a sector. The smallest collection of consecutive bytes addressable on a disk drive. In integrated storage elements, a block contains 512 bytes of data, error codes, flags, and the block address header.
bootstrapping	A method used to bring a system or device into a defined state by means of its own action. For example, a machine routine whose first few instructions are enough to bring the rest of the routine into the computer from an input device.
built-in self-test	A diagnostic test performed by the array controller software on the controller policy processor.
byte	A binary character string made up of 8 bits operated on as a unit.
cache memory	A portion of memory used to accelerate read and write operations.
CCITT	Acronym for Consultive Committee International Telephone and Telegraph. An international association that sets worldwide communication standards, recently renamed International Telecommunications Union (ITU).
CDU	Cable distribution unit. The power entry device for <i>StorageWorks</i> cabinets. The CDU provides the connections necessary to distribute power to the cabinet shelves and fans.
channel	An interface which allows high speed transfer of large amounts of data. Another term for a SCSI bus. <i>See also</i> SCSI.
chunk	A block of data written by the host.
chunk size	The number of data blocks, assigned by a system administrator, written to the primary RAIDset or stripeset member before the remaining data blocks are written to the next RAIDset or stripeset member.
CLCP	An abbreviation for code-load code-patch utility.
CLI	<i>See</i> command line interpreter.
coax	<i>See</i> coaxial cable.
coaxial cable	A two-conductor wire in which one conductor completely wraps the other with the two separated by insulation.
cold swap	A method of device replacement that requires the entire subsystem to be turned off before the device can be replaced. <i>See also</i> hot swap and warm swap.

command line interpreter	The configuration interface to operate the controller software.
configuration file	A file that contains a representation of a storage subsystem configuration.
container	1) Any entity that is capable of storing data, whether it is a physical device or a group of physical devices. (2) A virtual, internal controller structure representing either a single disk or a group of disk drives linked as a storageset. Stripesets and mirrorsets are examples of storageset containers the controller uses to create units.
controller	A hardware device that, with proprietary software, facilitates communications between a host and one or more devices organized in an array. HS family controllers are examples of array controllers.
copying	A state in which data to be copied to the mirrorset is inconsistent with other members of the mirrorset. <i>See also</i> normalizing.
copying member	Any member that joins the mirrorset after the mirrorset is created is regarded as a copying member. Once all the data from the normal member (or members) is copied to a normalizing or copying member, the copying member then becomes a normal member. <i>See also</i> normalizing member.
CSR	An acronym for control and status register.
DAEMON	Pronounced “demon.” A program usually associated with a UNIX system that performs a utility (housekeeping or maintenance) function without being requested or even known of by the user. A daemon is a diagnostic and execution monitor.
data center cabinet	A generic reference to large <i>Compaq</i> subsystem cabinets, such as the SW600-series and SW800-series cabinets in which <i>StorageWorks</i> components can be mounted.
data striping	The process of segmenting logically sequential data, such as a single file, so that segments can be written to multiple physical devices (usually disk drives) in a round-robin fashion. This technique is useful if the processor is capable of reading or writing data faster than a single disk can supply or accept the data. While data is being transferred from the first disk, the second disk can locate the next segment.

device	<i>See</i> node and peripheral device.
differential I/O module	A 16-bit I/O module with SCSI bus converter circuitry for extending a differential SCSI bus. <i>See also</i> I/O module.
differential SCSI bus	A bus in which a signal level is determined by the potential difference between two wires. A differential bus is more robust and less subject to electrical noise than is a single-ended bus.
DILX	Disk inline exerciser. The controller diagnostic software used to test the data transfer capabilities of disk drives in a way that simulates a high level of user activity.
DIMM	Dual inline Memory Module.
dirty data	The write-back cached data that has not been written to storage media, even though the host operation processing the data has completed.
DMA	Direct Memory Access.
DOC	DWZZA-On-a-Chip. An NCR53C120 SCSI bus extender chip used to connect a SCSI bus in an expansion cabinet to the corresponding SCSI bus in another cabinet.
driver	A hardware device or a program that controls or regulates another device. For example, a device driver is a driver developed for a specific device that allows a computer to operate with the device, such as a printer or a disk drive.
dual-redundant configuration	A controller configuration consisting of two active controllers operating as a single controller. If one controller fails, the other controller assumes control of the failing controller devices.
dual-simplex	A communications protocol that allows simultaneous transmission in both directions in a link, usually with no flow control.
DUART	Dual universal asynchronous receiver and transmitter. An integrated circuit containing two serial, asynchronous transceiver circuits.
ECB	External cache battery. The unit that supplies backup power to the cache module in the event the primary power source fails or is interrupted.
ECC	Error checking and correction.
EDC	Error detection code.

EIA	The abbreviation for Electronic Industries Association. EIA is a standards organization specializing in the electrical and functional characteristics of interface equipment. Same as Electronic Industries Association.
EMU	Environmental monitoring unit. A unit that provides increased protection against catastrophic failures. Some subsystem enclosures include an EMU which works with the controller to detect conditions such as failed power supplies, failed blowers, elevated temperatures, and external air sense faults. The EMU also controls certain cabinet hardware including DOC chips, alarms, and fan speeds.
ESD	Electrostatic discharge. The discharge of potentially harmful static electrical voltage as a result of improper grounding.
extended subsystem	A subsystem in which two cabinets are connected to the primary cabinet.
external cache battery	<i>See</i> ECB.
F_Port	A port in a fabric where an N_Port or NL_Port may attach.
fabric	A group of interconnections between ports that includes a fabric element.
failedset	A group of failed mirrorset or RAIDset devices automatically created by the controller.
failover	The process that takes place when one controller in a dual-redundant configuration assumes the workload of a failed companion controller. Failover continues until the failed controller is repaired or replaced.
FC-AL	The Fibre Channel Arbitrated Loop standard.
FC-ATM	ATM AAL5 over Fibre Channel
FC-FG	Fibre Channel Fabric Generic Requirements
FC-FP	Fibre Channel Framing Protocol (HIPPI on FC)
FC-GS-1	Fibre Channel Generic Services-1
FC-GS-2	Fibre Channel Generic Services-2
FC-IG	Fibre Channel Implementation Guide
FC-LE	Fibre Channel Link Encapsulation (ISO 8802.2)

FC-PH	The Fibre Channel Physical and Signaling standard.
FC-SB	Fibre Channel Single Byte Command Code Set
FC-SW	Fibre Channel Switched Topology and Switch Controls
FCC	Federal Communications Commission. The federal agency responsible for establishing standards and approving electronic devices within the United States.
FCC Class A	This certification label appears on electronic devices that can only be used in a commercial environment within the United States.
FCC Class B	This certification label appears on electronic devices that can be used in either a home or a commercial environment within the United States.
FCP	The mapping of SCSI-3 operations to Fibre Channel.
FDDI	Fiber Distributed Data Interface. An ANSI standard for 100 megabaud transmission over fiber optic cable.
FD SCSI	The fast, narrow, differential SCSI bus with an 8-bit data transfer rate of 10 MB/s. <i>See also</i> FWD SCSI and SCSI.
fiber	A fiber or optical strand. Spelled fibre in Fibre Channel.
fiber optic cable	A transmission medium designed to transmit digital signals in the form of pulses of light. Fiber optic cable is noted for its properties of electrical isolation and resistance to electrostatic contamination.
FL_Port	A port in a fabric where N_Port or an NL_Port may be connected.
flush	The act of writing dirty data from cache to a storage media.
FMU	Fault management utility.
forced errors	A data bit indicating a corresponding logical data block contains unrecoverable data.
frame	An invisible unit used to transfer information in Fibre Channel.
FRU	Field replaceable unit. A hardware component that can be replaced at the customer location by <i>Compaq</i> service personnel or qualified customer service personnel.

FRUTIL	Field Replacement utility.
full duplex (adj)	Pertaining to a communications method in which data can be transmitted and received at the same time.
full duplex (n)	A communications system in which there is a capability for 2-way transmission and acceptance between two sites at the same time.
FWD SCSI	A fast, wide, differential SCSI bus with a maximum 16-bit data transfer rate of 20 MB/s. <i>See also</i> SCSI and FD SCSI.
GBIC	Gigabyte interface converter.
giga	A prefix indicating a billion (10^9) units, as in gigabaud or gigabyte.
gigabaud	An encoded bit transmission rate of one billion (10^9) bits per second.
gigabyte	A value normally associated with a disk drives storage capacity, meaning a billion (10^9) bytes. The decimal value 1024 is usually used for one thousand.
GLM	Gigabit link module.
half-duplex (adj)	Pertaining to a communications system in which data can be either transmitted or received but only in one direction at one time.
hard address	The AL_PA which an NL_Port attempts to acquire during loop initialization.
HIPPI-FC	Fibre Channel over HIPPI.
host	The primary or controlling computer to which a storage subsystem is attached.
host adapter	A device that connects a host system to a SCSI bus. The host adapter usually performs the lowest layers of the SCSI protocol. This function may be logically and physically integrated into the host system.
hot disks	A disk containing multiple hot spots. Hot disks occur when the workload is poorly distributed across storage devices which prevents optimum subsystem performance. <i>See also</i> hot spots.
hot pluggable	<i>See</i> hot swap.

hot spots	<p>A portion of a disk drive frequently accessed by the host. Because the data being accessed is concentrated in one area, rather than spread across an array of disks providing parallel access, I/O performance is significantly reduced.</p> <p><i>See also</i> hot disks.</p>
hot swap	<p>A method of device replacement that allows normal I/O activity on a device bus to continue during device removal and insertion. The device being removed or inserted is the only device that cannot perform operations during this process. Also known as hot pluggable.</p> <p><i>See also</i> cold swap and warm swap.</p>
HSUTIL	<p>Format and device code load utility.</p>
IBR	<p>Initial Boot Record.</p>
ILF	<p>Illegal function.</p>
INIT	<p>Initialize input and output.</p>
initiator	<p>A SCSI device that requests an I/O process to be performed by another SCSI device, namely, the SCSI target. The controller is the initiator on the device bus. The host is the initiator on the host bus.</p>
instance code	<p>A four-byte value displayed in most text error messages and issued by the controller when a subsystem error occurs. The instance code indicates when during software processing the error was detected.</p>
interface	<p>A set of protocols used between components, such as cables, connectors, and signal levels.</p>
I/O	<p>Refers to input and output functions.</p>
I/O driver	<p>The set of code in the kernel that handles the physical I/O to a device. This is implemented as a fork process. Same as driver.</p>
I/O interface	<p><i>See</i> interface.</p>
I/O module	<p>A 16-bit SBB shelf device that integrates the SBB shelf with either an 8-bit single ended, 16-bit single-ended, or 16-bit differential SCSI bus.</p>
I/O operation	<p>The process of requesting a transfer of data from a peripheral device to memory (or visa versa), the actual transfer of the data, and the processing and overlaying activity to make both of those happen.</p>

IPI	Intelligent Peripheral Interface. An ANSI standard for controlling peripheral devices by a host computer.
IPI-3 Disk	Intelligent Peripheral Interface Level 3 for Disk
IPI-3 Tape	Intelligent Peripheral Interface Level 3 for Tape
JBOD	Just a bunch of disks. A term used to describe a group of single-device logical units.
kernel	The most privileged processor access mode.
L_Port	A node or fabric port capable of performing arbitrated loop functions and protocols. NL_Ports and FL_Ports are loop-capable ports.
LBN	Logical Block Number.
LED	Light Emitting Diode.
link	A connection between two Fibre Channel ports consisting of a transmit fibre and a receive fibre.
local connection	A connection to the subsystem using either its serial maintenance port or the host SCSI bus. A local connection enables you to connect to one subsystem controller within the physical range of the serial or host SCSI cable.
local terminal	A terminal plugged into the EIA-423 maintenance port located on the front bezel of the controller. <i>See also</i> maintenance terminal.
logical block number	<i>See</i> LBN.
logical bus	A single-ended bus connected to a differential bus by a SCSI bus signal converter.
logical unit	A physical or virtual device addressable through a target ID number. LUNs use their target bus connection to communicate on the SCSI bus.
logical unit number	A value that identifies a specific logical unit belonging to a SCSI target ID number. A number associated with a physical device unit during a task's I/O operations. Each task in the system must establish its own correspondence between logical unit numbers and physical devices.

logon	Also called login. A procedure whereby a participant, either a person or network connection, is identified as being an authorized network participant.
loop	<i>See</i> arbitrated loop.
loop_ID	A seven-bit value numbered contiguously from zero to 126-decimal and represent the 127 legal AL_PA values on a loop (not all of the 256 hex values are allowed as AL_PA values per FC-AL).
loop tenancy	The period of time between the following events: when a port wins loop arbitration and when the port returns to a monitoring state.
LRU	Least recently used. A cache term used to describe the block replacement policy for read cache.
maintenance terminal	An EIA-423-compatible terminal used with the controller. This terminal is used to identify the controller, enable host paths, enter configuration information, and check the controller status. The maintenance terminal is not required for normal operations. <i>See also</i> local terminal.
Mbps	Approximately one million (10^6) bits per second—that is, megabits per second.
MBps	Approximately one million (10^6) bytes per second—that is, megabytes per second.
member	A container that is a storage element in a RAID array.
metadata	The data written to a disk for the purposes of controller administration. Metadata improves error detection and media defect management for the disk drive. It is also used to support storage set configuration and partitioning. Nontransportable disks also contain metadata to indicate they are uniquely configured for <i>StorageWorks</i> environments. Metadata can be thought of as “data about data.”
mirrored write-back caching	A method of caching data that maintains two copies of the cached data. The copy is available if either cache module fails.
mirroring	The act of creating an exact copy or image of data.
mirrorset	<i>See</i> RAID level 1.
MIST	Module Integrity Self-Test.

N_Port	A port attached to a node for use with point-to-point topology or fabric topology.
network	A data communication, a configuration in which two or more terminals or devices are connected to enable information transfer.
NL_Port	A port attached to a node for use in all three topologies.
node	In data communications, the point at which one or more functional units connect transmission lines. In Fibre Channel, a device that has at least one N_Port or NL_Port.
nominal membership	The desired number of mirrorset members when the mirrorset is fully populated with active devices. If a member is removed from a mirrorset, the actual number of members may fall below the “nominal” membership.
Non-L_Port	A Node of Fabric port that is not capable of performing the Arbitrated Loop functions and protocols. N_Ports and F_Ports loop-capable ports.
non-participating mode	<p>A mode within an L_Port that inhibits the port from participating in loop activities. L_Ports in this mode continue to retransmit received transmission words but are not permitted to arbitrate or originate frames. An L_Port in non-participating mode may or may not have an AL_PA.</p> <p><i>See also</i> participating mode.</p>
nonredundant controller configuration	(1) A single controller configuration. (2) A controller configuration that does not include a second controller.
normal member	A mirrorset member that, block-for-block, contains the same data as other normal members within the mirrorset. Read requests from the host are always satisfied by normal members.
normalizing	Normalizing is a state in which, block-for-block, data written by the host to a mirrorset member is consistent with the data on other normal and normalizing members. The normalizing state exists only after a mirrorset is initialized. Therefore, no customer data is on the mirrorset.

normalizing member	<p>A mirrorset member whose contents is the same as all other normal and normalizing members for data that has been written since the mirrorset was created or lost cache data was cleared. A normalizing member is created by a normal member when either all of the normal members fail or all of the normal members are removed from the mirrorset.</p> <p><i>See also</i> copying member.</p>
NVM	<p>Non-Volatile Memory. A type of memory where the contents survive power loss. Also sometimes referred to as NVMEM.</p>
OCP	<p>Operator control panel. The control or indicator panel associated with a device. The OCP is usually mounted on the device and is accessible to the operator.</p>
offset	<p>A relative address referenced from the base element address. Event Sense Data Response Templates use “offsets” to identify various information contained within the one byte of memory (bits 0 through 7).</p>
other controller	<p>The controller in a dual-redundant pair that is connected to the controller serving your current CLI session.</p> <p><i>See also</i> this controller.</p>
outbound fiber	<p>One fiber in a link that carries information away from a port.</p>
parallel data transmission	<p>A data communication technique in which more than one code element (for example, bit) of each byte is sent or received simultaneously.</p>
parity	<p>A method of checking if binary numbers or characters are correct by counting the ONE bits. In odd parity, the total number of ONE bits must be odd; in even parity, the total number of ONE bits must be even. Parity information can be used to correct corrupted data. RAIDsets use parity to improve the availability of data.</p>
parity bit	<p>A binary digit added to a group of bits that checks to see if errors exist in the transmission.</p>
parity check	<p>A method of detecting errors when data is sent over a communications line. With even parity, the number of ones in a set of binary data should be even. With odd parity, the number of ones should be odd.</p>
participating mode	<p>A mode within an L_Port that allows the port to participate in loop activities. A port must have a valid AL_PA to be in participating mode.</p>
parity RAID	<p><i>See</i> RAIDset.</p>

partition	A logical division of a container, represented to the host as a logical unit.
PCM	Polycenter Console Manager.
PCMCIA	Personal Computer Memory Card Industry Association. An international association formed to promote a common standard for PC card-based peripherals to be plugged into notebook computers. The card, commonly known as a PCMCIA card or program card, is about the size of a credit card. <i>See also</i> program card.
peripheral device	Any unit, distinct from the CPU and physical memory, that can provide the system with input or accept any output from it. Terminals, printers, tape drives, and disks are peripheral devices.
point-to-point connection	A network configuration in which a connection is established between two, and only two, terminal installations. The connection may include switching facilities.
port	(1) In general terms, a logical channel in a communications system. (2) The hardware and software used to connect a host controller to a communications bus, such as a SCSI bus or serial bus. Regarding the controller, the port is (1) the logical route for data in and out of a controller that can contain one or more channels, all of which contain the same type of data. (2) The hardware and software that connects a controller to a SCSI device.
port_name	A 64-bit unique identifier assigned to each Fibre Channel port. The Port_Name is communicated during the logon and port discovery process.
preferred address	The AL_PA which an NL_Port attempts to acquire first during initialization.
primary cabinet	The primary cabinet is the subsystem enclosure that contains the controllers, cache modules, external cache batteries, and the PVA module.
private NL_Port	An NL_Port which does not attempt login with the fabric and only communicates with NL_Ports on the same loop.
program card	The PCMCIA card containing the controller operating software. <i>See also</i> PCMCIA.
protocol	The conventions or rules for the format and timing of messages sent and received.

PTL	Port-Target-LUN. The controller method of locating a device on the controller device bus.
pluggable	<i>See</i> warm swap.
public NL_Port	An NL_Port that attempts login with the fabric and can observe the rules of either public or private loop behavior. A public NL_Port may communicate with both private and public NL_Ports.
PVA module	Power Verification and Addressing module.
quiesce	The act of rendering bus activity inactive or dormant. For example, “quiesce the SCSI bus operations during a device warm swap.”
RAID	Redundant Array of Independent Disks. Represents multiple levels of storage access developed to improve performance or availability or both.
RAID level 0	A RAID storage set that stripes data across an array of disk drives. A single logical disk spans multiple physical disks, allowing parallel data processing for increased I/O performance. While the performance characteristics of RAID level 0 is excellent, this RAID level is the only one that does not provide redundancy. Raid level 0 storage sets are sometimes referred to as stripe sets.
RAID level 0+1	A RAID storage set that stripes data across an array of disks (RAID level 0) and mirrors the striped data (RAID level 1) to provide high I/O performance and high availability. This RAID level is alternatively called a striped mirror set. Raid level 0+1 storage sets are sometimes referred to as striped mirror sets.
RAID level 1	A RAID storage set of two or more physical disks that maintains a complete and independent copy of the entire virtual disk's data. This type of storage set has the advantage of being highly reliable and extremely tolerant of device failure. Raid level 1 storage sets are sometimes referred to as mirror sets.
RAID level 3	A RAID storage set that transfers data parallel across the array disk drives a byte at a time, causing individual blocks of data to be spread over several disks serving as one enormous virtual disk. A separate redundant check disk for the entire array stores parity on a dedicated disk drive within the storage set. <i>See also</i> RAID level 5.

RAID level 3/5	A Compaq-developed RAID storage set that stripes data and parity across three or more members in a disk array. A RAID set combines the best characteristics of RAID level 3 and RAID level 5. A RAID set is the best choice for most applications with small to medium I/O requests, unless the application is write intensive. A RAID set is sometimes called parity RAID. RAID level 3/5 storage sets are sometimes referred to as RAID sets.
RAID level 5	A RAID storage set that, unlike RAID level 3, stores the parity information across all of the disk drives within the storage set. <i>See also</i> RAID level 3.
RAID set	<i>See</i> RAID level 3/5.
RAM	Random access memory.
read ahead caching	A caching technique for improving performance of synchronous sequential reads by prefetching data from disk.
read caching	A cache management method used to decrease the subsystem response time to a read request by allowing the controller to satisfy the request from the cache memory rather than from the disk drives.
reconstruction	The process of regenerating the contents of a failed member's data. The reconstruct process writes the data to a spare set disk and then incorporates the spare set disk into the mirror set, striped mirror set, or RAID set from which the failed member came. <i>See also</i> regeneration.
reduced	Indicates that a mirror set or RAID set is missing one member because the member has failed or has been physically removed.
redundancy	The provision of multiple interchangeable components to perform a single function in order to cope with failures and errors. A RAID set is considered to be redundant when user data is recorded directly to one member and all of the other members include associated parity information.
regeneration	(1) The process of calculating missing data from redundant data. (2) The process of recreating a portion of the data from a failing or failed drive using the data and parity information from the other members within the storage set. The regeneration of an entire RAID set member is called reconstruction. <i>See also</i> reconstruction.

remote copy	A feature intended for disaster tolerance and replication of data from one storage subsystem or physical site to another subsystem or site. It also provides methods of performing a backup at either the local or remote site. With remote copy, user applications continue to run while data movement goes on in the background. Data warehousing, continuous computing, and enterprise applications all require remote copy capabilities.
remote copy set	A bound set of two units, one located locally and one located remotely for long distance mirroring. The units can be a single disk, or a storage set, mirror set, or RAID set. A unit on the local controller is designated as the “initiator” and a corresponding unit on the remoted controller is designated as the “target.” <i>See also</i> association set.
replacement policy	The policy specified by a switch with the SET FAILEDSET command indicating whether a failed disk from a mirror set or RAID set is to be automatically replaced with a disk from the spare set. The two switch choices are AUTOSPARE and NOAUTOSPARE.
request rate	The rate at which requests are arriving at a servicing entity.
RFI	Radio frequency interference. The disturbance of a signal by an unwanted radio signal or frequency.
SBB	<i>StorageWorks</i> building block. (1) A modular carrier plus the interface required to mount the carrier into a standard <i>StorageWorks</i> shelf. (2) any device conforming to shelf mechanical and electrical standards installed in a 3.5-inch or 5.25-inch carrier, whether it is a storage device or power supply.
SCSI	Small computer system interface. (1) An ANSI interface standard defining the physical and electrical parameters of a parallel I/O bus used to connect initiators to devices. (2) a processor-independent standard protocol for system-level interfacing between a computer and intelligent devices including hard drives, floppy disks, CD-ROMs, printers, scanners, and others.
SCSI-A cable	A 50-conductor (25 twisted-pair) cable generally used for single-ended, SCSI-bus connections.

SCSI bus signal converter	<p>Sometimes referred to as an adapter. (1) A device used to interface between the subsystem and a peripheral device unable to be mounted directly into the SBB shelf of the subsystem. (2) a device used to connect a differential SCSI bus to a single-ended SCSI bus. (3) A device used to extend the length of a differential or single-ended SCSI bus.</p> <p><i>See also</i> I/O module.</p>
SCSI device	<p>(1) A host computer adapter, a peripheral controller, or an intelligent peripheral that can be attached to the SCSI bus. (2) Any physical unit that can communicate on a SCSI bus.</p>
SCSI device ID number	<p>A bit-significant representation of the SCSI address referring to one of the signal lines, numbered 0 through 7 for an 8-bit bus, or 0 through 15 for a 16-bit bus.</p> <p><i>See also</i> target ID number.</p>
SCSI ID number	<p>The representation of the SCSI address that refers to one of the signal lines numbered 0 through 15.</p>
SCSI-P cable	<p>A 68-conductor (34 twisted-pair) cable generally used for differential bus connections.</p>
SCSI port	<p>(1) Software: The channel controlling communications to and from a specific SCSI bus in the system. (2) Hardware: The name of the logical socket at the back of the system unit to which a SCSI device is connected.</p>
serial transmission	<p>A method transmission in which each bit of information is sent sequentially on a single channel rather than simultaneously as in parallel transmission.</p>
service rate	<p>The rate at which an entity is able to service requests For example, the rate at which an Arbitrated Loop is able to service arbitrated requests.</p>
signal converter	<p><i>See</i> SCSI bus signal converter.</p>
SIMM	<p>Single Inline Memory Module.</p>
single-ended I/O module	<p>A 16-bit I/O module.</p> <p><i>See also</i> I/O module.</p>
single-ended SCSI bus	<p>An electrical connection where one wire carries the signal and another wire or shield is connected to electrical ground. Each signal logic level is determined by the voltage of a single wire in relation to ground. This is in contrast to a differential connection where the second wire carries an inverted signal.</p>

spareset	A collection of disk drives made ready by the controller to replace failed members of a storageset.
storage array	An integrated set of storage devices.
storage array subsystem	<i>See</i> storage subsystem.
storage subsystem	The controllers, storage devices, shelves, cables, and power supplies used to form a mass storage subsystem.
storage unit	The general term that refers to storagesets, single-disk units, and all other storage devices that are installed in your subsystem and accessed by the host. A storage unit can be any entity that is capable of storing data, whether it is a physical device or a group of physical devices.
storageset	(1) A group of devices configured with RAID techniques to operate as a single container. (2) Any collection of containers, such as stripesets, mirrorsets, striped mirrorsets, and RAIDsets.
<i>StorageWorks</i>	<p>A family of <i>Compaq</i> modular data storage products that allow customers to design and configure their own storage subsystems. Components include power, packaging, cabling, devices, controllers, and software. Customers can integrate devices and array controllers in <i>StorageWorks</i> enclosures to form storage subsystems.</p> <p><i>StorageWorks</i> systems include integrated SBBs and array controllers to form storage subsystems. System-level enclosures to house the shelves and standard mounting devices for SBBs are also included.</p>
stripe	The data divided into blocks and written across two or more member disks in an array.
striped mirrorset	<i>See</i> RAID level 0+1.
stripe size	The stripe capacity as determined by $n-1$ times the chunksize, where n is the number of RAIDset members.
stripeset	<i>See</i> RAID level 0.

striping	<p>The technique used to divide data into segments, also called chunks. The segments are striped, or distributed, across members of the stripeset. This technique helps to distribute hot spots across the array of physical devices to prevent hot spots and hot disks.</p> <p>Each stripeset member receives an equal share of the I/O request load, improving performance.</p>
surviving controller	<p>The controller in a dual-redundant configuration pair that serves its companion devices when the companion controller fails.</p>
switch	<p>A method that controls the flow of functions and operations in software.</p>
synchronous	<p>Pertaining to a method of data transmission which allows each event to operate in relation to a timing signal.</p> <p><i>See also</i> asynchronous.</p>
tape	<p>A storage device supporting sequential access to variable sized data records.</p>
target	<p>(1) A SCSI device that performs an operation requested by an initiator. (2) Designates the target identification (ID) number of the device.</p>
this controller	<p>The controller that is serving your current CLI session through a local or remote terminal.</p> <p><i>See also</i> other controller.</p>
topology	<p>An interconnection scheme that allows multiple Fibre Channel ports to communicate with each other. For example, point-to-point, Arbitrated Loop, and switched fabric are all Fibre Channel topologies.</p>
transfer data rate	<p>The speed at which data may be exchanged with the central processor, expressed in thousands of bytes per second.</p>
ULP	<p>Upper Layer Protocol.</p>
ULP process	<p>A function executing within a Fibre Channel node which conforms to the Upper Layer Protocol (ULP) requirements when interacting with other ULP processes.</p>
UltraSCSI bus	<p>A wide, Fast-20 SCSI bus.</p>

unit	<p>A container made accessible to a host. A unit may be created from a single disk drive or tape drive. A unit may also be created from a more complex container such as a RAIDset. The controller supports a maximum of eight units on each target.</p> <p><i>See also</i> target and target ID number.</p>
unwritten cached data	<p>Sometimes called unflushed data.</p> <p><i>See</i> dirty data.</p>
UPS	<p>Uninterruptable power supply. A battery-powered power supply guaranteed to provide power to an electrical device in the event of an unexpected interruption to the primary power supply. Uninterruptable power supplies are usually rated by the amount of voltage supplied and the length of time the voltage is supplied.</p>
VHDCI	<p>Very high-density-cable interface. A 68-pin interface. Required for Ultra-SCSI connections.</p>
virtual terminal	<p>A software path from an operator terminal on the host to the controller's CLI interface, sometimes called a host console. The path can be established via the host port on the controller (using HSZterm) or via the maintenance port through an intermediary host.</p>
VTDPY	<p>An abbreviation for Virtual Terminal Display Utility.</p>
warm swap	<p>A device replacement method that allows the complete system remains online during device removal or insertion. The system bus may be halted, or quiesced, for a brief period of time during the warm swap procedure. Also known as pluggable.</p> <p><i>See also</i> cold swap and hot swap.</p>
Worldwide name	<p>A unique 64-bit number assigned to a subsystem by the Institute of Electrical and Electronics Engineers (IEEE) and set by <i>Compaq</i> manufacturing prior to shipping. This name is referred to as the node ID within the CLI.</p>
write-back caching	<p>A cache management method used to decrease the subsystem response time to write requests by allowing the controller to declare the write operation "complete" as soon as the data reaches its cache memory. The controller performs the slower operation of writing the data to the disk drives at a later time.</p>

**write-through
cache**

A cache management technique for retaining host write requests in read cache. When the host requests a write operation, the controller writes data directly to the storage device. This technique allows the controller to complete some read requests from the cache, greatly improving the response time to retrieve data. The operation is complete only after the data to be written is received by the target storage device.

This cache management method may update, invalidate, or delete data from the cache memory accordingly, to ensure that the cache contains the most current data.

**write-through
caching**

A cache management method used to decrease the subsystem response time to a read. This method allows the controller to satisfy the request from the cache memory rather than from the disk drives.

write hole

The period of time in a RAID level 1 or RAID level 5 write operation when an opportunity emerges for undetectable RAIDset data corruption. Write holes occur under conditions such as power outages, where the writing of multiple members can be abruptly interrupted. A battery backed-up cache design eliminates the write hole because data is preserved in cache and unsuccessful write operations can be retried.

Index

A

adding

- cache memory 5–19

- DIMMs 5–19

array controller. *See* controller.

ASC/ASCQ codes 7–17

ASC_ASCQ codes 6–29

B

BA370 enclosure

- 180 W power supply part number 1–3

- AC input box part number 1–3

- cache module part number 1–3

- controller front panel connectors, switches and LEDs 1–11

- controller OCP switches and LEDs 1–12

- cooling fan part number 1–3

- disk drives, supported drives and part numbers 1–3

- dual-battery ECB part number 1–3

- ECB Y-cable part numbers 1–10

- EMU connectors, switches, and LEDs 1–16

- EMU part number 1–3

- EMU-EMU communication cable part number 1–6

- Fibre Channel optical cable part number 1–9

- GLM connectors and components 1–13

- GLM part number 1–9

- HSG80 controller part number 1–3

- I/O module part number 1–3

- maintenance port cable part number 1–9

- power cable kit part number 1–3

- power cable part number 1–3

- power supply LEDs 1–14

- program (PCMCIA) card part numbers 1–9

- PVA module connectors and switches 1–15

- PVA module part number 1–3

- rack-mountable enclosure part number 1–3

- single-battery ECB part number 1–3

backup power source, enabling write-back

caching 6–13

battery hysteresis 6–2

C

cables, ECB Y-cable part number

- BA370 enclosure 1–10

- data center rack 1–10

cache module

- companion cache module 1–10

- general description 1–10

- illustration of parts 1–10

- installing
 - dual-redundant controller
 - configuration 3-27, 4-19
 - single-controller configuration 3-10, 4-8
 - read caching 6-12
 - removing
 - dual-redundant controller
 - configuration 3-24, 4-17
 - single-controller configuration 3-9, 4-8
 - replacing
 - dual-redundant controller
 - configuration 3-24, 4-17
 - single-controller configuration 3-8, 4-7
 - replacing cache modules with FRUTIL 6-56
 - write-back caching 6-13
 - write-through caching 6-13
- cache policies. *See* caching techniques.
- caching techniques 6-12
 - fault-tolerance for write-back caching 6-14
 - general description 6-12
 - read caching 6-12
 - read-ahead caching 6-12
 - write-back caching 6-13
 - write-through caching 6-13
- caution defined xvi
- change volume serial number utility. *See* CHVSN utility.
- charging diagnostics
 - battery hysteresis 6-2
 - general description 6-2
- checking Fibre Channel link errors 6-43
- CHVSN utility general description 6-57
- CLCP
 - downloading new software 5-4
 - installing patches 5-7
- CLCP utility general description 6-56
- cleaning instructions, Fibre Channel optical cable 2-5
- CLI event reporting, no controller termination 6-27
- CLONE utility general description 6-56
- code load and code patch utility. *See* CLCP utility.
- codes
 - ASC/ASCQ 7-17
 - ASC_ASCQ 6-29
 - component identifier codes 7-93
 - device_type 6-29
 - event codes 6-29
 - event threshold codes 7-21
 - instance 6-29, 7-22 to 7-45
 - last failure 7-45 to 7-86
 - last_failure 6-29
 - repair action 7-88 to 7-92
 - repair_action 6-29
 - structure of events and last failures 6-28
 - translating 6-29
 - types of 6-29
- component codes 6-29
- component identifier codes 7-93
- CONFIG utility general description 6-55
- configuration
 - map of devices in subsystem 6-38
 - upgrading to dual-redundant controller 5-15
- configuration utility. *See* CONFIG utility.
- configuring a dual-redundant controller
- configurations with mirrored cache 6-17
- connecting
 - local connection to the controller 2-3
 - PC connection to the controller 2-3
 - terminal connection to the controller 2-3
- controller
 - “this” and “other” defined xvi
 - “this” and “other”
 - defined xvi
 - checking communication with devices 6-37
 - checking communication with host 6-34
 - checking transfer rate with host 6-34
 - dual-redundant controller configurations with mirrored cache 6-17
- ECB diagnostics 6-2

- Fibre Channel optical cabling
 - illustration of parts 1-8
 - part numbers of parts used in configuring 1-9
 - parts used in configuring 1-9
- general description 1-3, 1-5
- installing
 - dual-redundant controller
 - configuration 3-22, 4-16
 - single-controller configuration 3-7, 4-6
- local connection 2-3
- patching controller software with the CLCP utility 6-56
- removing
 - dual-redundant controller
 - configuration 3-19, 4-14
 - single-controller configuration 3-5, 4-4
- replacing
 - dual-redundant controller
 - configuration 3-19, 4-14
 - single-controller configuration 3-5, 4-4
- self-test 6-1
- shutting down 3-1
 - 4-1
- upgrading software 5-2
- controller and its cache module
 - installing in a dual-redundant controller
 - configuration 3-16, 4-13
 - removing in a dual-redundant controller
 - configuration 3-12, 4-11
 - replacing
 - dual-redundant controller
 - configuration 3-12, 4-11
 - single-controller configuration 3-5, 4-4
- controller front panel connectors, switches and LEDs 1-11
- controller OCP switches and LEDs 1-12
- controller specifications. *See also* specifications. A-1
- controller termination events 6-18
 - flashing OCP LEDs 6-19
 - solid OCP LEDs 6-21

- controller termination events, last failure reporting 6-25
- controller, cache module, and ECB upgrade installation 5-15
- conventions
 - “this controller” and “other controller” defined xvi
 - typographical xv
 - warnings, cautions, importants, notes xv

D

- DAEMON tests 6-1
- data center rack, ECB Y-cable 1-10
- data duplicating with the CLONE utility 6-56
- data patterns for DILX write test 6-52
- deleting
 - patches 5-7, 5-8
 - software patches 5-7, 5-8
- describing event codes 6-29
- device ports, checking status 6-40
- device_type codes 6-29
- devices
 - adding with the CONFIG utility 6-55
 - checking
 - I/O 6-39
 - port status 6-40
 - status 6-39
 - checking communication with controller 6-37
 - exercising 6-50
 - finding 6-50
 - generating a new volume serial number with the CHVSN utility 6-57
 - mapping in subsystem 6-38
 - renaming the volume serial number with the CHVSN utility 6-57
 - replacing 2-15
 - testing read and write capability 6-51
 - testing read capability 6-50
 - upgrading firmware 5-12
- diagnostics, ECB charging 6-2
- DILX 6-50

DIMMs

- installing
 - dual-redundant controller
 - configuration 2-10
 - single-configuration controller 2-10
- removing
 - dual-redundant controller
 - configuration 2-10
 - single-configuration controller 2-10
- replacing
 - dual-redundant controller
 - configuration 2-9
 - single-configuration controller 2-9
- disabling the ECBs, shutting down the subsystem 3-2
- disk drives
 - adding with the CONFIG utility 6-55
 - generating a new volume serial number with the CHVSN utility 6-57
 - renaming the volume serial number with the CHVSN utility 6-57
- See also* devices.
- displaying
 - current FMU settings 6-32
 - event codes 6-29
 - last failure codes 6-28
 - memory-system failures 6-28
- documentation, related xvii
- downloading software 5-4
- dual-redundant controller configuration
 - installing
 - cache module 3-27, 4-19
 - controller 3-22, 4-16
 - controller and its cache module 3-16, 4-13
 - DIMMs 2-10
 - GLM 2-8
 - removing
 - cache module 3-24, 4-17
 - controller 3-19, 4-14
 - controller and its cache module 3-12, 4-11
 - DIMMs 2-10

- GLM 2-7, 2-8
- replacing
 - BA370 enclosure ECB with subsystem
 - powered off 3-33
 - BA370 enclosure ECB with subsystem
 - powered on 3-31
 - cache module 3-24, 4-17
 - controller 3-19, 4-14
 - controller and its cache module 3-12, 4-11
 - DIMMs 2-9
 - ECB 3-31, 4-20
 - I/O module 3-39, 4-23
 - program (PCMCIA) card 2-14
- replacing controller and cache modules 3-11, 4-10
- upgrading from a single-controller to a dual-redundant controller
 - configuration 5-15

E

ECB

- BA370 enclosure, replacing
 - dual-redundant controller
 - configuration 3-31
 - single-configuration controller 3-31
- battery hysteresis 6-2
- diagnostics 6-2
- disabling, shutting down a BA370 subsystem 3-2
- enabling, shutting down a BA370 subsystem 3-2
- Model 2200 enclosure
 - LEDs 1-18
 - replacing in all controller
 - configurations 4-20
- replacing ECBs with FRUTIL 6-56
- replacing with the BA370 subsystem
 - powered off
 - dual-redundant controller
 - configuration 3-33
 - single-controller configuration 3-33

- replacing with the BA370 subsystem
 - powered on
 - dual-redundant controller
 - configuration 3-31
 - single-controller configuration 3-31
 - electrical specifications A-1
 - electrostatic discharge precautions 2-2
 - EMU
 - BA370 enclosure connectors, switches, and LEDs 1-16
 - Model 2200 enclosure switches and LEDs 1-17
 - enabling the ECBs, shutting down the subsystem 3-2
 - environmental specifications
 - nonoperating A-2
 - operating A-2
 - event codes
 - list 7-21
 - structure 6-28
 - translating 6-29
 - types 6-29
 - event threshold codes 6-29
 - events
 - controller termination 6-18
 - flashing OCP LEDs 6-19
 - last failure reporting 6-25
 - solid OCP LEDs 6-21
 - no controller termination 6-25
 - CLI event reporting 6-27
 - spontaneous event log 6-26
 - exercising drives and units 6-50

F

- fan LEDs, Model 2200 enclosure 1-19
- fault remedy table 6-5
- fault-tolerance for write-back caching
 - general description 6-13
 - nonvolatile memory 6-13

- fiber cable
 - installing
 - dual-redundant controller
 - configuration 2-13
 - single-configuration controller 2-13
 - removing
 - dual-redundant controller
 - configuration 2-12
 - single-configuration controller 2-12
 - replacing
 - dual-redundant controller
 - configuration 2-12
 - single-configuration controller 2-12
- Fibre Channel
 - 8-/16-port switch part number 1-5
 - 8-/16-port switch, part number 1-3
 - host status display 6-44
 - hub, part number 1-3, 1-5
 - link error 6-43
 - optical cable, cleaning instructions 2-5
- field replacement utility. *See* FRUTIL.
- finding devices 6-50
- firmware upgrading with HSUTIL 5-12
- flashing OCP LED events, controller termination 6-19
- FMU
 - displaying current display settings 6-32
 - enabling
 - event logging 6-31
 - repair action logging 6-31
 - timestamp 6-32
 - verbose logging 6-31
 - general description 6-27
 - interpreting
 - last failures 6-27
 - memory-system failures 6-27
 - logging last failure codes 6-31
 - setting display for 6-31
 - translating event codes 6-29
- FRUTIL general description 6-56

G

- GBIC part number 1-3, 1-5
- GLM
 - connectors and components 1-13
 - installing
 - dual-redundant controller configuration 2-8
 - single-configuration controller 2-8
 - removing
 - dual-redundant controller configuration 2-8
 - single-configuration controller 2-8
 - replacing
 - dual-redundant controller configuration 2-7
 - single-configuration controller 2-7

H

- host port, checking status 6-34
- host, checking transfer rate to controller 6-34
- HSG80 array controller. *See* controller.
- HSUTIL
 - general description 6-54
 - upgrading device firmware 5-12
- hub
 - installing
 - dual-redundant controller configuration 2-13
 - single-configuration controller 2-13
 - removing
 - dual-redundant controller configuration 2-12
 - single-configuration controller 2-12
 - replacing
 - dual-redundant controller configuration 2-12
 - single-configuration controller 2-12
- hysteresis. *See* battery hysteresis.

I

- I/O
 - checking to devices 6-39
 - checking to host 6-34
 - checking to units 6-41
 - I/O module
 - replacing
 - dual-redundant controller configuration 3-39, 4-22
 - single-controller configuration 3-39, 4-22
 - important defined xvii
 - installing
 - cache module
 - dual-redundant controller configuration 3-27, 4-19
 - single-controller configuration 3-10, 4-8
 - controller
 - dual-redundant controller configuration 3-22, 4-16
 - single-controller configuration 3-7, 4-6
 - controller and its cache module,
 - dual-redundant controller configuration 3-16, 4-13
 - controller, cache module, and ECB 5-15
 - DIMMs
 - dual-redundant controller configuration 2-10
 - single-controller configuration 2-10
 - dual-redundant controller configuration
 - cache module 3-27, 4-19
 - controller 3-22, 4-16
 - controller and its cache module 3-16, 4-13
 - DIMMs 2-10
 - fiber cable 2-13
 - GLM 2-8
 - hub 2-13
 - switch 2-13
- fiber cable 2-13
 - dual-redundant controller configuration 2-13
 - single-controller configuration 2-13
 - GLM 2-8

- hub 2-13
 - dual-redundant controller
 - configuration 2-13
 - single-controller configuration 2-13
- mirrorset member 2-16
- patches 5-7
- program (PCMCIA) card, new 5-2
- RAIDset member 2-16
- single-controller configuration
 - cache module 3-10, 4-8
 - controller 3-7, 4-6
 - DIMMs 2-10
 - fiber cable 2-13
 - GLM 2-8
 - hub 2-13
- software patches 5-7
- switch
 - dual-redundant controller
 - configuration 2-13
 - single-controller configuration 2-13
- instance codes 7-22 to 7-45
 - structure 6-28
 - translating 6-29
- interpreting event codes 6-28

L

- last failure codes
 - displaying 6-28
 - list 7-45 to 7-86
 - logging 6-31
 - structure 6-28
 - translating 6-29
- last failure reporting, controller termination events 6-25
- link errors, Fibre Channel 6-43
- listing
 - patches 5-7, 5-10
 - software patches 5-7, 5-10
- local connection, connecting to the controller 2-3
- locating devices 6-50

- logging
 - enabling in FMU 6-31
 - enabling verbose logging 6-31
 - timestamping 6-32

M

- maintenance port
 - precautions 2-3
 - terminal or PC connection 2-3
- maintenance port cable. *See* maintenance port, terminal or PC connection.
- map of devices in subsystem 6-38
- member, replacing 2-15
- memory-system failures 6-28
- mirrored write-back cache enabling 6-17
- mirrorset member
 - installing 2-16
 - removing 2-16
- mirrorsets, duplicating data with the CLONE utility 6-56
- Model 2200 enclosure
 - 180 W power supply part number 1-5
 - blank bezel part number 1-5
 - cache module part number 1-5
 - controller front panel—connectors, switches and LEDs 1-11
 - controller OCP—switches and LEDs 1-12
 - ECB battery pack part number 1-5
 - ECB LEDs 1-18
 - ECB part number 1-5
 - EMU part number 1-5
 - EMU switches and LEDs 1-17
 - fan LEDs 1-19
 - fan part number 1-5
 - Fibre Channel optical cable part number 1-9
 - GLM connectors and components 1-13
 - GLM part number 1-9
 - HSG80 controller part number 1-5
 - I/O module part number 1-5
 - maintenance port cable part number 1-9
 - power supply LEDs 1-14
 - program (PCMCIA) card part numbers 1-9

- rack-mountable part number 1-5
- UPS communication cable part number 1-7

N

- nonoperating specifications, environmental A-2
- nonvolatile memory, fault-tolerance for write-back caching 6-13
- note defined xvii

O

- operating specifications, environmental A-2
- other controller – defined xvi

P

- part numbers

- BA370 enclosure
 - 180 W power supply 1-3
 - AC input box 1-3
 - cache module 1-3
 - cooling fan 1-3
 - dual-battery ECB 1-3
 - ECB Y-cable 1-10
 - ECB Y-cable for a data center rack 1-10
 - EMU 1-3
 - EMU-EMU communication cable 1-6
 - Fibre Channel optical cable 1-9
 - GLM 1-9
 - HSG80 controller 1-3
 - I/O module 1-3
 - maintenance port cable 1-9
 - power cable 1-3
 - power cable kit 1-3
 - program (PCMCIA) cards 1-9
 - PVA module 1-3
 - single-battery ECB part number 1-3
 - supported disk drives 1-3
- BA370 rack-mountable enclosure 1-3
- Fibre Channel
 - 8-/16-port switch 1-3, 1-5
 - hub 1-3, 1-5
 - optical cabling, parts used in configuring the controller 1-9

- GBIC 1-3, 1-5
- Model 2200 enclosure
 - 180 W power supply 1-5
 - blank bezel 1-5
 - cache module 1-5
 - ECB 1-5
 - ECB battery pack 1-5
 - EMU 1-5
 - fan 1-5
 - Fibre Channel optical cable 1-9
 - GLM 1-9
 - HSG80 controller 1-5
 - I/O module 1-5
 - maintenance port cable 1-9
 - program (PCMCIA) cards 1-9
 - UPS communication cable 1-7
- Model 2200 rack-mountable enclosure 1-5
- patches
 - deleting 5-8
 - installing 5-7
 - listing 5-10
 - listing, installing, deleting 5-7
- PCMCIA card. *See* program card. 2-14
- physical specifications A-1
- power source, enabling write-back caching 6-13
- power supply LEDs 1-14
- power, verification, and addressing module. *See* PVA module.
- precautions
 - electrostatic discharge 2-2
 - maintenance port 2-3
- problem solving 6-3
- program (PCMCIA) card 2-14
 - installing a new card 5-2
- replacing
 - dual-redundant controller configuration 2-14
 - single-configuration controller 2-14
- publications, related xvii
- PVA module
 - connectors and components 1-15

- replacing
 - dual-redundant controller
 - configuration 3-35
 - single-configuration controller 3-35
- R**
- RAIDset member
 - installing 2-16
 - removing 2-16
- rate of transfer, checking to host 6-34
- read caching
 - enabled for all storage units 6-12
 - general description 6-12
- read capability, testing 6-50
- read requests
 - anticipating subsequent read requests with
 - read-ahead caching 6-12
 - decreasing the subsystem response time with
 - read caching 6-12

See also write requests.
- read-ahead caching 6-12
- read-ahead caching enabled for all disk units 6-12
- reduced storageset 2-15
- related publications xvii
- remedies for a problem 6-5
- removing
 - cache module
 - dual-redundant controller
 - configuration 3-24, 4-17
 - single-controller configuration 3-9, 4-8
 - controller
 - dual-redundant controller
 - configuration 3-19, 4-14
 - single-controller configuration 3-5, 4-4
 - controller and its cache module,
 - dual-redundant controller
 - configuration 3-12, 4-11
 - DIMMs
 - dual-redundant controller
 - configuration 2-10
 - single-controller configuration 2-10
 - dual-redundant controller configuration
 - cache module 3-24, 4-17
 - controller 3-19, 4-14
 - controller and its cache module 3-12, 4-11
 - DIMMs 2-10
 - fiber cable 2-12
 - GLM 2-8
 - hub 2-12
 - switch 2-12
 - failed mirrorset member 2-16
 - failed RAIDset member 2-16
 - fiber cable
 - dual-redundant controller
 - configuration 2-12
 - single-controller configuration 2-12
 - GLM 2-8
 - hub
 - dual-redundant controller
 - configuration 2-12
 - single-controller configuration 2-12
 - single-controller configuration
 - cache module 3-9, 4-8
 - controller 3-5, 4-4
 - DIMMs 2-10
 - fiber cable 2-12
 - GLM 2-8
 - hub 2-12
 - switch 2-12
 - switch
 - dual-redundant controller
 - configuration 2-12
 - single-controller configuration 2-12
- repair action codes
 - list 7-88 to 7-92
 - logging 6-31
 - translating 6-29
- replacing
 - cache module
 - dual-redundant controller
 - configuration 3-24, 4-17
 - single-controller configuration 3-8, 4-7

- controller
 - dual-redundant controller
 - configuration 3-19, 4-14
 - single-controller configuration 3-5, 4-4
 - controller and cache modules
 - dual-redundant controller
 - configuration 3-11, 4-10
 - single-controller configuration 3-4, 4-3
 - controller and its cache module
 - dual-redundant controller
 - configuration 3-12, 4-11
 - single-controller configuration 3-5, 4-4
 - DIMMs
 - dual-redundant controller
 - configuration 2-9
 - single-controller configuration 2-9
 - dual-redundant controller configuration
 - cache module 3-24, 4-17
 - controller 3-19, 4-14
 - controller and its cache module 3-12, 4-11
 - DIMMs 2-9
 - ECB 3-31
 - BA370 subsystem powered off 3-33
 - BA370 subsystem powered on 3-31
 - fiber cable 2-12
 - GLM 2-7
 - hub 2-12
 - I/O module 3-39, 4-22
 - program (PCMCIA) card 2-14
 - PVA module 3-35
 - PVA module, master enclosure 3-35
 - switch 2-12
- ECB
- BA370 subsystem powered off 3-33
 - BA370 subsystem powered on 3-31
 - Model 2200 enclosure 4-21
- fiber cable
- dual-redundant controller
 - configuration 2-12
 - single-controller configuration 2-12
- GLM 2-7
- hub
- dual-redundant controller
 - configuration 2-12
 - single-controller configuration 2-12
- I/O module 3-39, 4-22
- program (PCMCIA) card 2-14
- PVA module 3-35
- single-controller configuration
- cache module 3-8, 4-7
 - controller 3-5, 4-4
 - DIMMs 2-9
 - ECB 3-31
 - BA370 subsystem powered off 3-33
 - BA370 subsystem powered on 3-31
 - fiber cable 2-12
 - GLM 2-7
 - hub 2-12
 - I/O module 3-39, 4-22
 - program (PCMCIA) card 2-14
 - PVA module 3-35
 - PVA module, master enclosure 3-35
 - switch 2-12
- storageset member 2-15
- switch
- dual-redundant controller
 - configuration 2-12
 - single-controller configuration 2-12
- required tools 2-1
- restart_type codes 6-29
- restarting the subsystem 3-3, 4-2
- running
- controller self-test 6-1
 - DAEMON tests 6-1
 - DILX 6-50
 - FMU 6-28
 - VTDPY 6-33
- S**
- SCSI command operations 6-29
- self-test 6-1

- shutting down the subsystem 3-1, 4-1
 - disabling the ECBs 3-2
 - enabling the ECBs 3-2
- significant event reporting 6-18
- single-controller configuration
 - installing
 - cache module 3-10, 4-8
 - controller 3-7, 4-6
 - DIMMs 2-10
 - GLM 2-8
 - removing
 - cache module 3-9, 4-8
 - controller 3-5, 4-4
 - DIMMs 2-10
 - GLM 2-8
 - replacing
 - BA370 enclosure ECB with subsystem powered off 3-33
 - BA370 enclosure ECB with subsystem powered on 3-31
 - BA370 enclosure I/O module 3-39
 - cache module 3-8, 4-7
 - controller 3-5, 4-4
 - controller and cache modules 3-4, 4-3
 - controller and its cache module 3-5, 4-4
 - DIMMs 2-9
 - ECB 3-31, 4-20
 - GLM 2-7
 - I/O module 4-23
 - program (PCMCIA) card 2-14
 - PVA module 3-35
 - upgrading to a dual-redundant controller configuration 5-15
- software patches 5-7
 - deleting 5-8
 - installing 5-7
 - listing 5-10
 - listing, installing, deleting 5-7
- software upgrading 5-2
- solid OCP LEDs events, controller termination 6-21
- specifications
 - controller electrical A-1
 - controller physical A-1
 - environmental
 - nonoperating A-2
 - operating A-2
- spontaneous event log, no controller termination 6-26
- starting the subsystem 3-3, 4-2
- status
 - device ports 6-40
 - devices 6-39
 - host port 6-34
 - units 6-41
- storage set member, replacing 2-15
- storage sets
 - adding devices with the CONFIG utility 6-55
 - duplicating data with the CLONE utility 6-56
 - generating a new volume serial number with the CHVSN utility 6-57
 - renaming the volume serial number with the CHVSN utility 6-57
- structure of event codes 6-28
- subsystem
 - restarting 3-3, 4-2
 - shutting down 3-1, 4-1
 - upgrading 5-1
- switch
 - installing
 - dual-redundant controller configuration 2-13
 - single-configuration controller 2-13
 - removing
 - dual-redundant controller configuration 2-12
 - single-configuration controller 2-12
 - replacing
 - dual-redundant controller configuration 2-12
 - single-controller configuration 2-12
- symptoms of a problem 6-5

T

- templates 7-17
- terminal connection. *See also* maintenance port.
- testing read capability 6-50
- this controller – defined xvi
- timestamp for logging 6-32
- tools 2-1
- transfer rate
 - checking to devices 6-37
 - checking to host 6-34
- translating event codes 6-29
- troubleshooting
 - checklist 6-3
 - CLCP utility 6-56
 - generating a new volume serial number with the CHVSN utility 6-57
 - patching controller software with the CLCP utility 6-56
 - renaming the volume serial number with the CHVSN utility 6-57
 - replacing cache modules with FRUTIL 6-56
 - replacing controllers with FRUTIL 6-56
 - replacing ECBs with FRUTIL 6-56
 - table 6-5
 - See also* CONFIG utility.
 - See also* HSUTIL.
- turning off the subsystem 3-1, 4-1
- turning on the subsystem 3-3, 4-2
- typographical conventions xv

U

- units
 - checking I/O 6-41
 - checking status 6-41
 - exercising 6-50
- unpartitioned mirrorsets, duplicating data with the CLONE utility 6-56
- upgrading
 - cache memory 5-19
 - controller software 5-2
 - controller software with the CLCP utility 6-56
 - device firmware 5-12

- DIMMs 5-19
- downloading new software 5-4
- EMU software with the CLCP utility 6-56
- from a single controller to a dual-redundant controller configuration 5-15
- installing
 - controller, cache module, and ECB 5-15
 - new program (PCMCIA) card 5-2
- using CLCP 5-7
 - deleting software patches 5-8
 - installing software patches 5-7
 - listing software patches 5-10
- utilities and exercisers
 - CHVSN utility 6-57
 - CLCP utility 6-56
 - CLONE utility 6-56
 - CONFIG utility 6-55
 - FRUTIL 6-56
 - HSUTIL 6-54

V

- verbose logging 6-31
- video terminal display. *See* VTDPY.
- volume serial number
 - generating a new one with the CHVSN utility 6-57
 - renaming with the CHVSN utility 6-57
- VTDPY
 - checking communication with host 6-34
 - commands 6-33
 - general description 6-33
 - running 6-33

W

- warning, defined xvi
- write capability, test for devices 6-51
- write requests
 - improving the subsystem response time with write-back caching 6-13
 - placing data with write-through caching 6-13
 - See also* read requests.

write-back caching
 enabled for all disk units 6-13
 fault-tolerance 6-13
 general description 6-13

write-through caching
 general description 6-13