



***Il Mondo dei Partner***  
***INNOVARE E CRESCERE. INSIEME*** **2006**  
*Milano 19 - 20 Ottobre* ***Technical World***

**Making the Most of Your Assets**  
*A System z Platform Approach for Advanced Data Serving*

Angelo Sironi  
Executive IT Architect



# Trademarks

AIX*	IBM eServer	z/VM*
CICS*	IBM logo*	zSeries*
DB2*	IMS	
DB2 Connect	On Demand Business logo	
DB2 Universal Database	Parallel Sysplex*	
DRDA*	System z	
FICON*	System z9	
GDPS*	WebSphere*	
HiperSockets	z/Architecture	
IBM*	z/OS*	

\* Registered trademarks of IBM Corporation

## The following are trademarks or registered trademarks of other companies.

Intel is a trademark of the Intel Corporation in the United States and other countries.

Linux is a registered trademark of Linus Torvalds in the United States, other countries, or both.

Java and all Java-related trademarks and logos are trademarks or registered trademarks of Sun Microsystems, Inc., in the United States and other countries.

Microsoft, Windows and Windows NT are registered trademarks of Microsoft Corporation.

UNIX is a registered trademark of The Open Group in the United States and other countries.

\* All other products may be trademarks or registered trademarks of their respective companies.

### Notes:

Performance is in Internal Throughput Rate (ITR) ratio based on measurements and projections using standard IBM benchmarks in a controlled environment. The actual throughput that any user will experience will vary depending upon considerations such as the amount of multiprogramming in the user's job stream, the I/O configuration, the storage configuration, and the workload processed. Therefore, no assurance can be given that an individual user will achieve throughput improvements equivalent to the performance ratios stated here.

IBM hardware products are manufactured from new parts, or new and serviceable used parts. Regardless, our warranty terms apply.

All customer examples cited or described in this presentation are presented as illustrations of the manner in which some customers have used IBM products and the results they may have achieved. Actual environmental costs and performance characteristics will vary depending on individual customer configurations and conditions.

This publication was produced in the United States. IBM may not offer the products, services or features discussed in this document in other countries, and the information may be subject to change without notice. Consult your local IBM business contact for information on the product or services available in your area.

All statements regarding IBM's future direction and intent are subject to change or withdrawal without notice, and represent goals and objectives only.

Information about non-IBM products is obtained from the manufacturers of those products or their published announcements. IBM has not tested those products and cannot confirm the performance, compatibility, or any other claims related to non-IBM products. Questions on the capabilities of non-IBM products should be addressed to the suppliers of those products.

Prices subject to change without notice. Contact your IBM representative or Business Partner for the most current pricing in your geography.

This presentation and the claims outlined in it were reviewed for compliance with US law. Adaptations of these claims for use in other geographies must be reviewed by the local country counsel for compliance with local laws.



## Raising the bar for Information on Demand



- Information on demand is essential for driving business strategies.
- Data is at the core of our customers' businesses, and must be leveraged for competitive advantage.
- For over four decades mainframes have been a leader in data and transaction serving.
- It's time to further leverage this asset, with technology innovations for advanced data serving:
  - New zIIP specialty engine
  - New DB2 V9.1 for z/OS
  - Planned future directions and roadmap

# New IBM System z9 Integrated Information Processor (IBM zIIP)

- New specialty engine for System z9 designed to help:
  - Customers integrate data across the enterprise
  - **Improve resource optimization and lower the cost of ownership for eligible data serving workloads**
- z/OS manages and directs work between the general purpose processor and the zIIP
  - **No changes anticipated to DB2 for z/OS V8 applications**
  - Number of zIIPs per z9-109 not to exceed number of standard processors
- DB2 for z/OS V8 will be first IBM exploiter of the zIIP with
  - System z9 109
  - z/OS 1.6 or later
  - **DB2 for z/OS V8**





# DB2 V8 exploitation of IBM zIIP can add value to database workloads

## Portions of the following DB2 for z/OS V8 workloads may benefit from zIIP\*

1. ERP, CRM, Business Intelligence and/or other enterprise applications
  - Via **DRDA**® over a **TCP/IP** connection
2. Data warehousing applications
  - Long running parallel queries, including complex **star schema parallel** queries
3. DB2 for z/OS V8 utilities
  - Internal DB2 utility functions used to **maintain index structures**

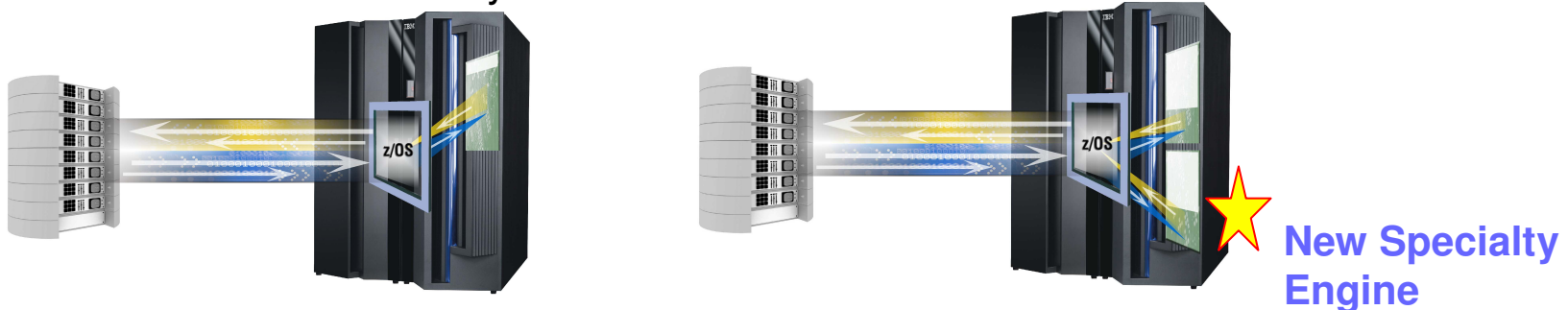

- The zIIP is designed so that a program can work with z/OS to have all or a portion of its enclave Service Request Block (SRB) work directed to the zIIP.
- The above types of DB2 V8 work are those executing in enclave SRBs, of which portions can be sent to the zIIP.

# Example 1: Enterprise Applications

Enterprise Applications that access DB2 for z/OS V8 via **DRDA** over a TCP/IP connection are dispatched within z/OS in enclave SRBs. z/OS will direct portions of these SQL requests to the zIIP

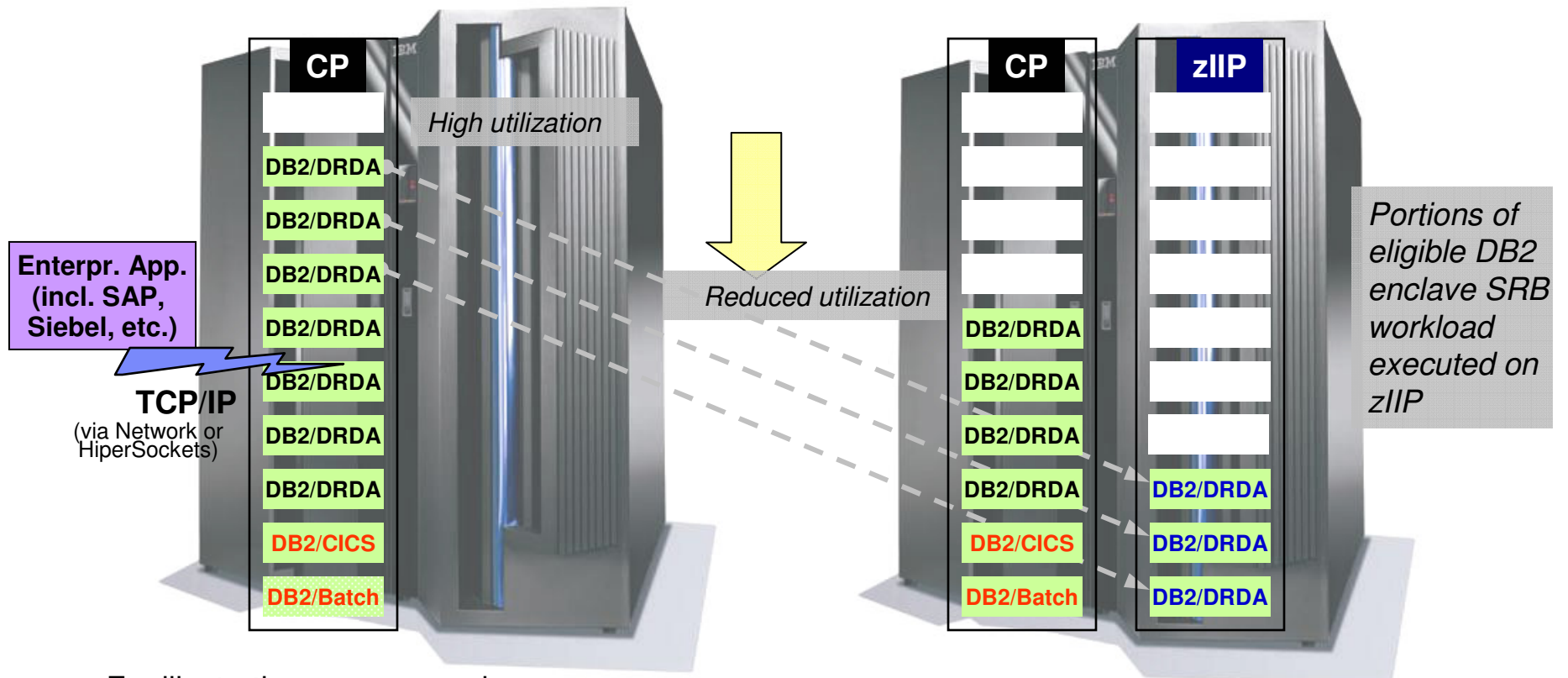

For illustrative purposes only

Actual workload redirects may vary



## Example 2: Business Intelligence Applications

Long running parallel queries will now use enclave SRBs. Long running parallel queries via **Local** connection or **DRDA** over a TCP/IP connection will have portions of this work directed to the zIIP.

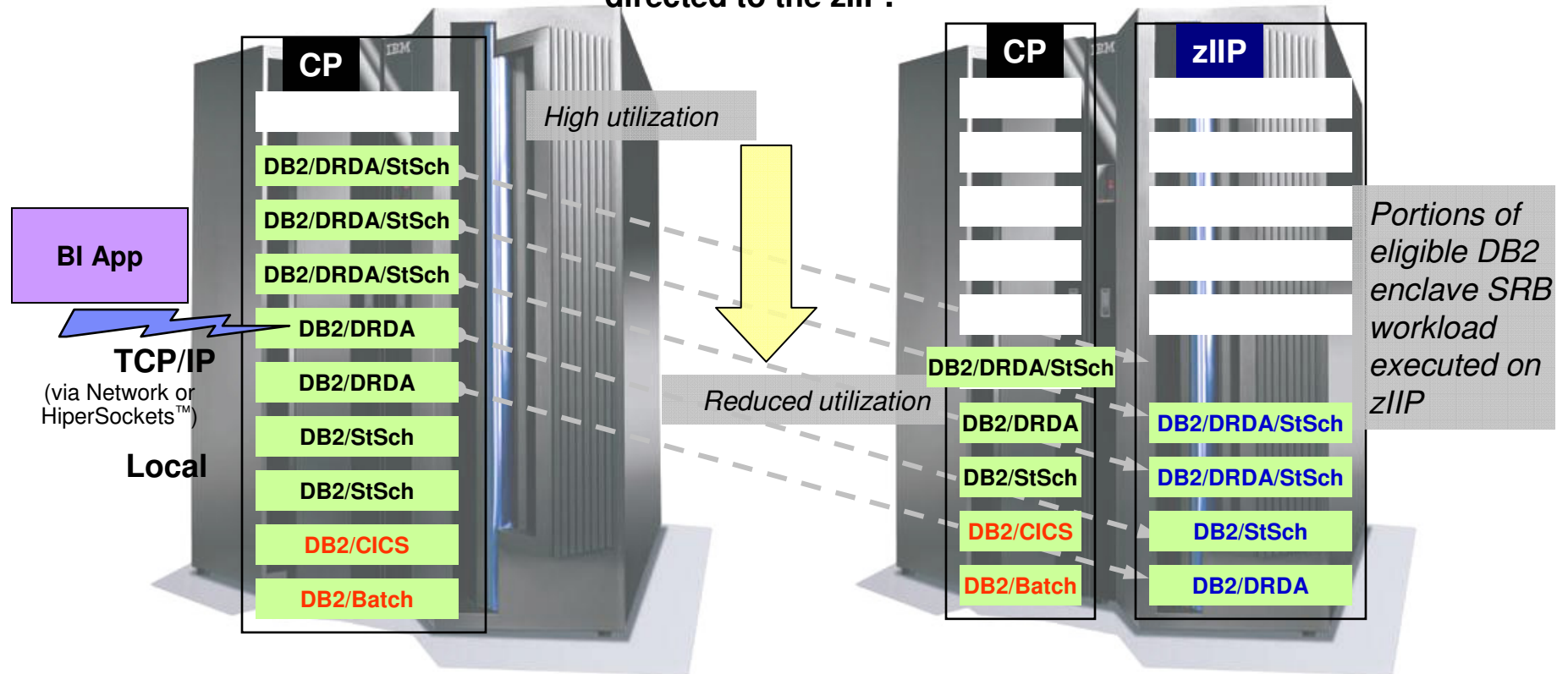

For illustrative purposes only

Actual workload redirects may vary

## Example 3: DB2 for z/OS utilities

DB2 utilities such as LOAD, REORG, and REBUILD will now use enclave SRBs for the portion of the processing that is related to **index maintenance**. z/OS directs to the zIIP a portion of the work related to index maintenance for the above utilities.

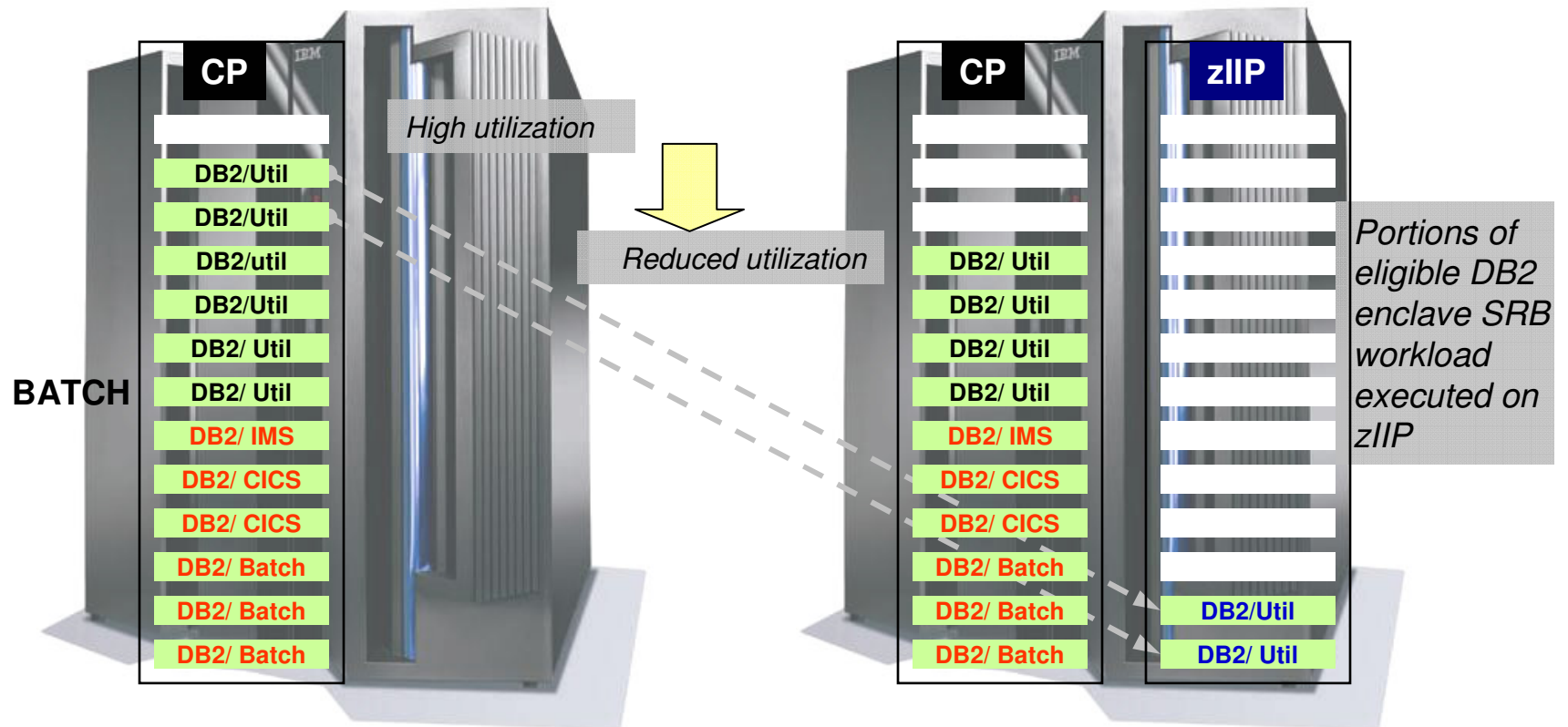

For illustrative purposes only, actual workload redirects may vary.



# Specialty engines

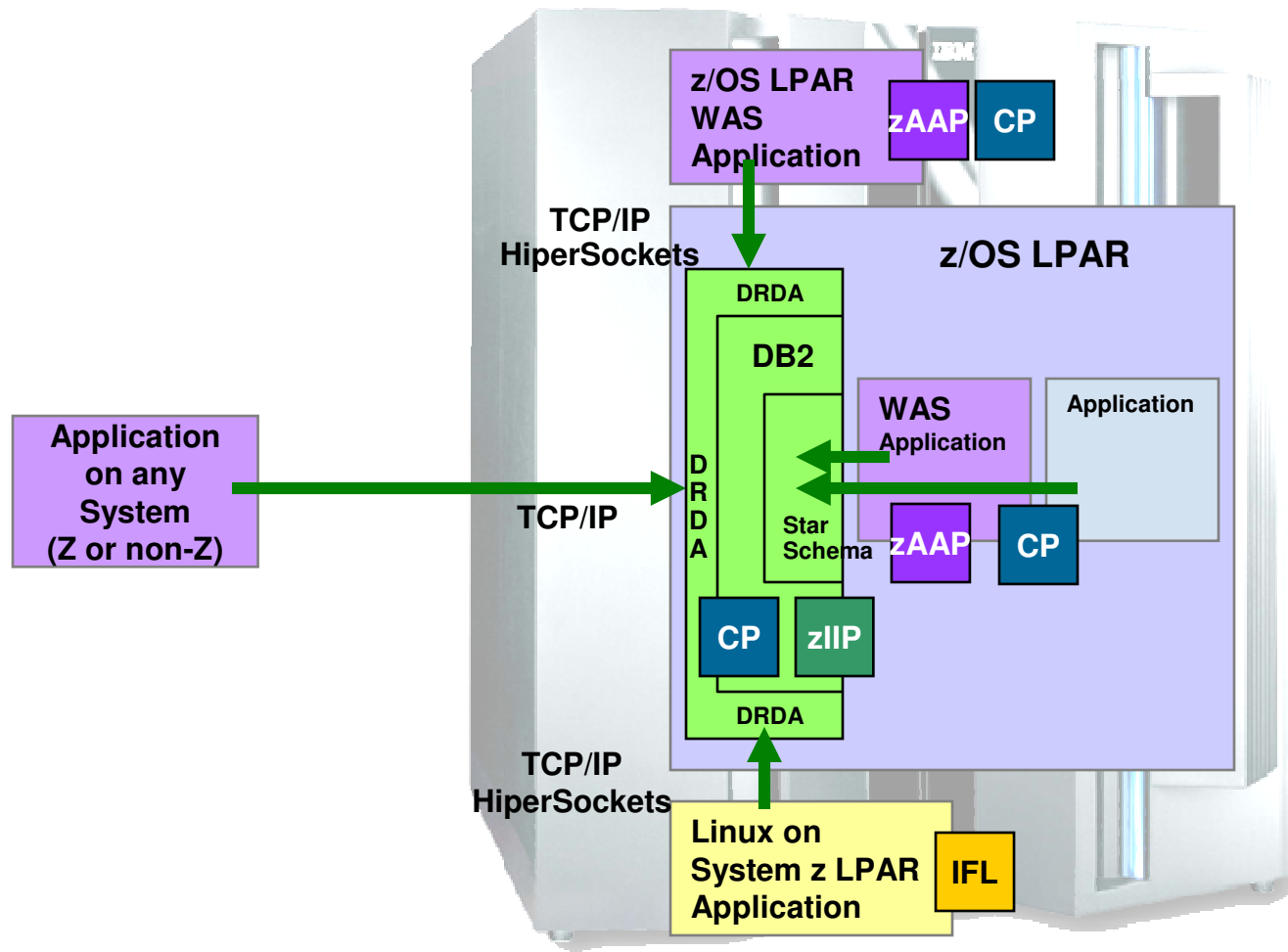

The IBM System z9 specialty engines can operate on the same machine together

# System z9 and DB2 for z/OS are an ideal data serving platform

## ▪ Data consolidation helps reduce:

- Multiple copies, disparate data
- Cost and complexity of back up and recovery
- Network traffic
- Amount of resources
- DB administration and management
- Risk associated with distributed privacy, security, and audit policies

## ▪ Leverage System z technology

- Parallel Sysplex clustering for scalability AND availability AND performance
- Data sharing = single view of the data
- Data compression for TCO
- Centralized backup, recovery, privacy, security and audit policies

## ▪ New System z9 specialty engine designed to help:

- Customers integrate data across enterprise
- Improve resource optimization
- Lower the TCO for data serving workloads

## BEFORE

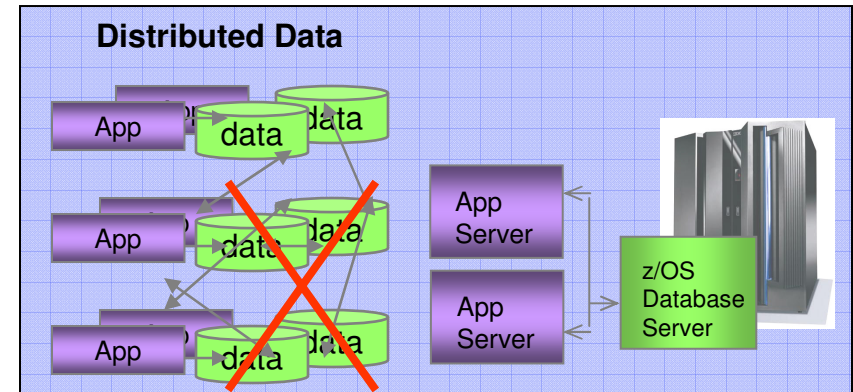

## AFTER

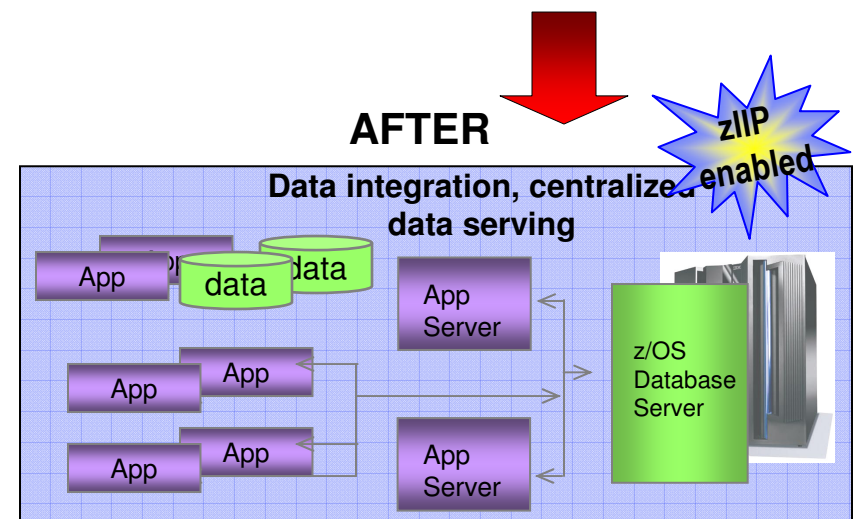

# Simplify and improve TCO by integration

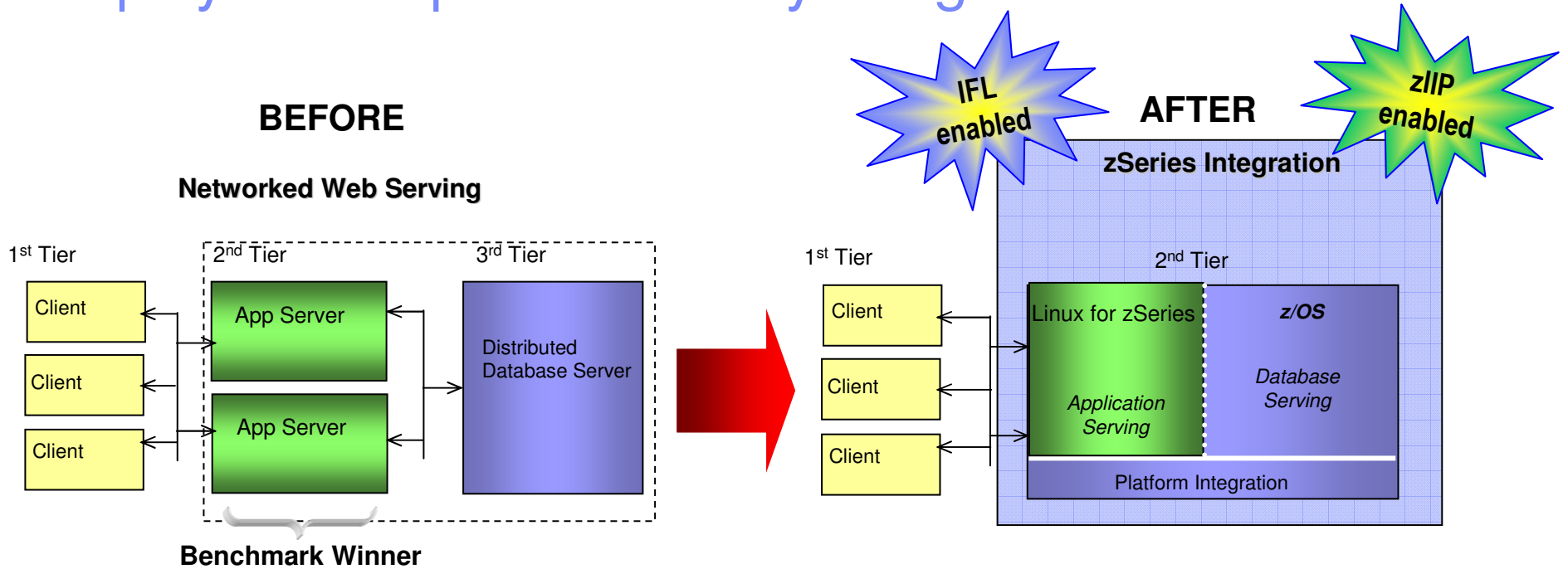

**Benchmark Winner**

Advantages of consolidating application-serving on zLinux with z/OS data serving

- ✓ Security
- ✓ Resilience
- ✓ Performance
- ✓ Operations
- ✓ Environmentals
- ✓ Availability
- ✓ DR

- Fewer points of intrusion
- Fewer Points of Failure
- Avoid Network Latency
- Fewer parts to manage
- Less Hardware
- Highest possible DB availability
- Integrated DR thru GDPS possible

Better Production Value

# Estimating how much work can go to zIIP PeopleSoft Enterprise Example

- **Current: z990 - 307**
  - PE Fin 8.9, DB2 V8, DB2 Connect + Legacy Apps
  - Adding HR 8.9 which requires 750 Mips
- **Estimate using**
  - DB2 Stats and Accounting trace records

OR

  - RMF WLM Service Class (DDF System) reports

	<b>System(s)</b>	<b>MSUs</b>	<b>“MIPS”</b>	<b>Delta MSUs</b>
<b>Current</b>	<b>z990-307</b>	<b>451</b>	<b>2709</b>	<b>-</b>
<b>Future w/o zIIP</b>	<b>Z990-310</b>	<b>601</b>	<b>3662</b>	<b>+33%</b>
<b>Future with zIIP</b>	<b>z9-705 w/ 2 zIIPs</b>	<b>363</b>	<b>2633</b>	<b>-19.5%</b>



## DB2 for z/OS V9.1 – Addressing corporate data goals Beta Shipment: June 2006

- **Evolve Your Environment & SOA**
  - **Integrated XML support**
  - WebSphere® integration
- **Simplify development and porting**
  - **Native SQL stored procedures**
  - Many SQL improvements that simplify porting
  - Automatic unique indexes to support primary keys
- **Decrease Complexity and Cost**
  - Fast table replacement
  - Partition by growth
  - Volume-based COPY/RECOVER
  - Optimization Service Center
- **Improved IT Infrastructure In Support of Compliance Efforts**
  - Trusted security context
  - Database roles
  - Auditing capabilities
  - Encryption improved

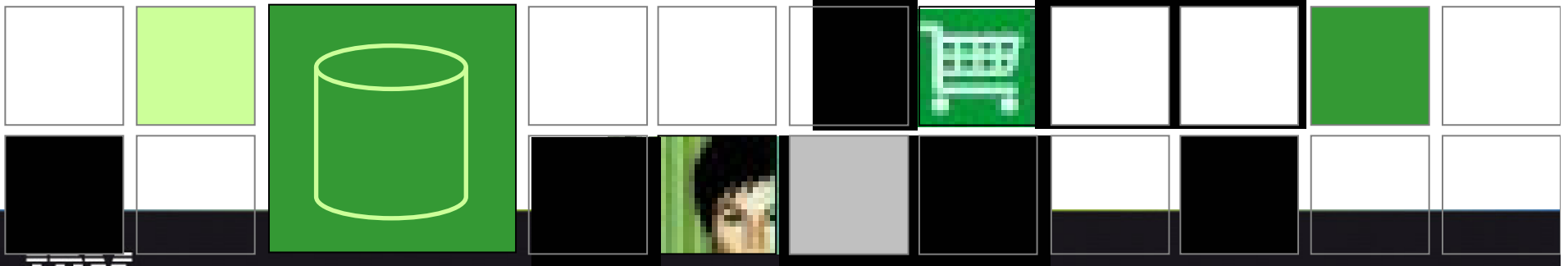

# A vision for System z advanced data serving

## *System z Enterprise Hub for Mission Critical Data*

- ❖ With a strong foundation for transaction processing, built on 40+ years of technology innovation, System z servers with z/OS and DB2 can provide a premiere platform for data serving, today and into the future\*
- ❖ IBM plans to continue to invest in new solutions to address customers' strategic information on demand goals\*



### **Today's Capabilities**

- Industry leading data integrity and security
- Data sharing solution for centralized view of data
- Scalability and availability for enterprise class workloads
- Comprehensive systems and data management environment



### **Extension of capabilities\***

- New specialty engine (zIIP) with DB2 exploitation - for mission critical ERP, CRM, and Data Warehousing workloads \*
- Database support improves regulatory compliance and autonomies
- Support of encryption capability (tape subsystem) with z/OS centralized key mgmt
- Data protection to achieve highest levels of security certifications



### **Future direction\***

- Additional zIIP exploitation
- DB2 enhancements to help improve usability and reduce complexity and management costs.
- **DB2 table scan acceleration via DS8000**
- Support of encryption capability (disk subsystem) with z/OS centralized key mgmt
- Handle larger volumes of data, with improved scalability

\*All statements regarding IBM's future direction and intent are subject to change or withdrawal without notice, and represent goals and objectives only.

# System z Data Serving Roadmap

## Today...

System z9 mainframes & z/OS combine for Industry Leading Performance, Scalability, Security, Availability and Virtual Partitioning capabilities with a focus on TCO improvements

DB2 Universal Database™ (UDB) for z/OS provides the premier high performance DBMS for high volume transaction workloads based on relational technology.

Security for z/OS and DB2 is designed to provide protection and advanced encryption capabilities with focus on recognized industry certifications

DB2 Content Manager for z/OS provides a foundation for managing, accessing, and integrating critical business information on demand.

WebSphere Information Integration Platform for z/OS can help you readily access your pertinent information to support strategic business initiatives

DB2 Business Intelligence Solutions for z/OS provides cost-effective, rapid access to your core business data for warehousing and analytics

IMS & DB2 for z/OS Tools & Utilities provide integrated and intelligent management & monitoring of your IMS & DB2 applications and performance

IMS Version 9 extends and enhances your Industry Leading IMS environment with increased connection & integration capabilities

## Tomorrow...

DB2 V8 Exploitation of a new specialty processor (zIIP – System z9 Integrated Information Processor)

- types of eligible DB2 for z/OS V8 work, portions of which can be sent to the zIIP include:

- Network Connected Application processing using DRDA over a TCP/IP connection
- Data Warehouse Query processing that utilize star scheme parallel queries
- Select index maintenance in the DB2 Utilities (LOAD, REORG, REBUILD)

DB2 for z/OS Enhancements

- Unmatched infrastructure for supporting customer needs for regulatory compliance and auditing
- Continue to improve people resources efficiency
- Integrated XML
- DB2 Spatial Data Support
- OmniFind Search in DB2

Security for z/OS and DB2 Enhancements

- Common Criteria EAL Certifications
- Support of encryption capability (tape subsystem) with z/OS centralized key mgmt

z/OS Scalability & Resource Management Enhancements

- Enhancements in Device Addressability
- WLM Dynamic DB2 Bufferpool Management
- z/OS Global Mirror (XRC) and Global Mirror (asynchronous PPRC) consistency groups

WebSphere Information Integration Platform

- zSeries legacy data replication

DB2 and IMS Tools Focus Areas

- New and enhanced tools in recovery and performance
- Additional Support for SAP environments, Content Management & Business Integration

IMS Enterprise Support on z/OS

- XQuery Support
- Integrated Connect XML Adapter support

## Future...

Further exploitation of zIIP

Additional DB2 for z/OS Enhancements

- Improve usability and reduce complexity
- Java Language Integrated Query
- DB2 Table Scan acceleration via DS8000 processing

Ongoing Security Enhancements

- Common Criteria EAL4 Certification for DB2
- Support of encryption capability (disk subsystem) with z/OS centralized key mgmt

System z9 server and z/OS Futures

- Continued FICON Enhancements
- Continued focus on Storage capability & capacity
- Heterogeneous File Sharing Support
- NFS V4 Client
- Continuous data protect
- Dynamic storage provisioning

DB2 CM for z/OS Advancements

- XML API and Web Services

WebSphere Information Integration Platform

- Expanded integration and process automation across and between platform components

DB2 and IMS Tools Focus Areas

- New function in change management
- Increased function to help meet compliance requirements
- Continued advancements in key functional areas

Additional IMS Futures

- Enhancing IMS XML and Web Services Connectivity
- Integrating Operations across Subsystems/Platforms
- Simplifying Installation and Management

\*All statements regarding IBM's future direction and intent are subject to change or withdrawal without notice, and represent goals and objectives only

# NEW zIIP Workload!!

- zIIP workload eligibility is going to be extended to the child portion of long running parallel queries. This new eligible workload will be directed to the zIIP specialty engine based on an internal CPU threshold. When the threshold is exceeded, the parallel child tasks initiated by a local or remote SNA connection can be directed to a zIIP. However, for DRDA workload (remote TCP/IP connections), a portion of the main and child tasks can be directed to a zIIP. For either operation, long running queries or star joins, parallelism does have to be enabled through the use of **DSNZPARM CDSSRDEF**, the BIND keyword **DEGREE (ANY)**, or dynamically with a **SET CURRENT DEGREE = 'ANY'**. This new function will be delivered by its own APAR in the very near future.
- There is a second change that has already been announced about zIIP eligible workload. With the announcement of DB2 9 for z/OS, zIIP has gained one more piece of potential work. DB2 9, when it becomes generally available, will deliver native SQL stored procedures that will run in the database engine. This is new and improved functionality over what has been available in releases prior to DB2 9.

Today, a stored procedure arrives as an enclave via the DDF address space and switches to TCB mode when it runs in the stored procedure address space. A native SQL stored procedure (as in DB2 9) will also arrive as an enclave through the DDF address space. But this is where the similarities end. The native SQL stored procedure is processed by the DBM1 address space like any other SQL statement and will remain in enclave mode. Because it runs as an enclave, it becomes zIIP eligible.

\*All statements regarding IBM's future direction and intent are subject to change or withdrawal without notice, and represent goals and objectives only



# NEW!!! zIIP BLOG

<http://blogs.ittoolbox.com/database/db2zos/archives/update-on-which-ziip-fixes-are-shipping-and-some-new-ziip-eligible-workload-10268>

\*All statements regarding IBM's future direction and intent are subject to change or withdrawal without notice, and represent goals and objectives only





Questions?