

z/OS Preventive Maintenance Strategy to Maintain System Availability

Authors:

*Dianne Gamarra
IBM Corporation
z/OS Software Service
Poughkeepsie, NY 12601
Phone (external): 845-435-9730
Phone (internal): 8-295-9730
Email: dgamarra@us.ibm.com*

*Allan Beckmann
IBM Corporation
z/OS Consolidated Service Test
Poughkeepsie, NY 12601
Phone (external): 845-435-4107
Phone (internal): 8-295-4107
Email: beckmann@us.ibm.com*

z/OS Preventive Maintenance Strategy to Maintain System Availability

Table of Contents

z/OS Preventive Maintenance Summary.....	3
Introduction	5
APARs	5
Notification of HIPER and PE Critical Fixes.....	6
IBM z/OS Preventive Service Deliverables.....	9
Recommended Service Upgrade (RSU) Preventive Maintenance Strategy.....	11
General Suggestions for Maintenance Practices.....	13
Conclusion	14

z/OS Preventive Maintenance Summary

Having a robust preventive maintenance process is a best practice in managing any IT environment including z/OS®. By avoiding known defects, which can have a major impact on the functioning of the system, preventive maintenance improves availability. Having a proactive preventive service strategy can reduce the number of rediscovered defects and help you avoid unplanned outages. IBM recommends that preventive maintenance be installed at least two to four times a year. In addition, IBM recommends that HIPER, PE Fix, Security/Integrity and Pervasive PTFs be installed more frequently.

One of IBM System z® with z/OS's strengths is its tight integration of the technologies across the hardware, firmware, operating system and middleware. To continue that strength throughout the products' lifecycle, IBM developed an additional test effort known as Consolidated Service Test (CST) and a recommended preventative maintenance strategy which is directly tied to this effort. The Recommended Service Upgrade (RSU) was introduced in 2001 and continues to provide a consistent, installable, and tested preventive maintenance level for the z/OS operating system, key subsystems such as CICS®, DB2®, IMS™, MQSeries®, WebSphere® Application Server, and many of the other IBM tools and products that run on the z/OS platform. For many years, each IBM product had its own preventive maintenance strategy and had its own recommendations as to what maintenance to install. The inconsistencies of the recommendations led to confusion. With the RSU recommendation, the benefit is that all IBM products have the same recommendation for preventive maintenance.

As part of IBM's commitment to quality, CST is a service environment that exists to test the maintenance for the operating system and key subsystems. The intent is to verify that the PTFs and products work well together, and to identify problems that might impact this process. The result of the testing is a package of maintenance across the product set that has been tested together. The testing done in CST is in addition to any testing that would be done prior to the release of the PTF as corrective service. The RSU provides integrated and tested service packages for the customer to install. The process used to create the RSU provides for a reduced risk of encountering defective maintenance (PEs). Since its introduction, the RSU has become accepted as the maintenance strategy by many of IBM's customers based on customer feedback and subscriptions to the CST website. Also based on feedback from many customers, their experience has shown that using the RSU results in more stable systems.

The CST environment consists of two Parallel Sysplexes running on a mixture of currently supported hardware and software products. CST simulates customer production-like workloads to exercise the products that are installed. Each of the Sysplexes in the CST environment is configured as a multi-site Geographically Dispersed Parallel Sysplex™ (GDPS®) with a Peer-To-Peer Remote Copy (PPRC) DASD configuration. Each Sysplex has GDPS Control Systems to ensure the orderly fail-over of all work if a site failure occurs. Site failures and both planned and unplanned HyperSwaps are performed on a monthly basis. On one Sysplex, processes are

interrupted and failures are forced to occur. The other Sysplex is used for stress and recovery testing, as well as longevity testing to expose problems that occur over time.

The general suggestion is for customers to stage the roll-out of the Recommended Service Upgrade (RSU) by product on any single system, and not change all the major products (such as z/OS, DB2, IMS, CICS, CTG, DB2 Connect™, GDPS, Java™, WebSphere MQ, WebSphere Application Server for z/OS, IBM DB2 and IMS Tools and z/OS Problem Determination Tools) all at once. Changing many products in a single system simultaneously may complicate the tasks of problem diagnosis and PTF back-out, if a severe problem occurs.

IBM recognizes that some customers have limited maintenance windows and need to upgrade several products at the same time. Therefore, IBM does test the “Big Bang” (maintenance for all products at the same time on a single image) method of rolling out maintenance to ensure that it works. It is particularly important that thorough customer application testing be done in this case, to avoid the need to back-out all of the maintenance.

Additional information about the RSU and CST, can be found at the CST website at:
<http://www.ibm.com/systems/z/os/zos/support/servicetest/>

Disclaimer

Please note that the service recommendations are based on testing in IBM’s CST environment. Your environment and applications will differ, and therefore your results may also differ.

Introduction

This paper reviews the concepts and tools available for servicing z/OS and IBM products running on the z/OS platform. It assumes that the reader is familiar with and has a basic understanding of the maintenance installation procedure.

Maintenance can be corrective or preventive. Corrective maintenance is necessary after a system has already encountered a problem. Regardless of the impact of the actual problem, the need to install the corrective maintenance may result in an unscheduled outage, which can have a larger impact. A preventive maintenance strategy enables you to schedule the servicing of the z/OS system based your business needs.

IBM recommends having an unambiguous process to install preventive maintenance on a regular basis. It is beneficial to understand the concepts and different aspects of the z/OS service principles in order to create a process that is well defined.

Preventive maintenance of IBM products is an integral part of system stability and essential for achieving the highest availability of your z/OS system. Proactively servicing your z/OS system will safeguard against failures and unnecessary outages that are caused by known problems with available fixes. Having a preventive maintenance strategy has proven to be effective, and is generally recommended by IBM.

IBM is committed to identify defects, to accurately diagnose the root cause of problems, and to provide quality fixes in a timely manner. The support team ensures that APARs are updated with precise information relevant to the acknowledged defect, and flags the APARs appropriately to aid in your service decisions. To complement these commitments, IBM has created the Recommended Service Upgrade (RSU) Maintenance Strategy. Following the RSU Maintenance Strategy reduces your exposure to known problems and improves overall availability.

APARs

IBM documents defects of z/OS products in Authorized Program Analysis Reports (APAR). Corrections for the defects are provided by IBM in a release level PTF (Program Temporary Fix). APARs also offer a means to supply a new function for a product that is already generally available. An APAR may be flagged by IBM under special circumstances that warrant extra attention.

- **HIPER**

APARs are marked HIPER for high impact problems, in which the problem addressed is critical and normal processing is adversely affected. Circumstances include, but are not limited to: the need to re-IPL, restart or recycle a subsystem in order to recover, loss of a major function, data loss, recursive or unrecoverable failures, and severe performance

degradation. HIPER APARs are considered severe and IBM suggests that the fix is installed or the circumvention is implemented as soon as possible.

- **SPECIAL ATTENTION**

APARs are marked SPECIAL ATTENTION if they are considered important for the customer to install. Situations include, but are not limited to: a new function to the product, problems encountered during the installation of the product, problems encountered during the installation of service updates, and problems related to a particular condition or environment.

- **PERVASIVE**

HIPER APARs and SPECIAL ATTENTION APARs may also be marked PERVASIVE. A pervasive APAR has high probability of affecting a large number of systems.

- **PE**

APARs may be marked to identify an error in a PTF after the PTF is made generally available. Situations that characterize a PE (PTF in Error) APAR include, but are not limited to: if the PTF solves the original problem but creates a new problem that did not previously exist, if the PTF does not solve the original problem, if the supplied SMP/E application control statements in the PTF contain errors or prohibit it from applying correctly, or there is a documentation error that negatively affects the system.

- **INTEGRITY/SECURITY**

Integrity APARs identify problems that might allow unauthorized access and compromise system controls. Security APARs address problems with existing security measures that might lead to security exposures to the system or to an IBM product that runs on the system. The content of Integrity and Security APARs is classified as IBM Confidential to protect all clients on the IBM System z platform from the exposure. Information that pertains to Integrity and Security APARs is available through the z Systems Security Portal. The portal enables z/OS licensed clients to receive information about the latest security and system integrity fixes and also provides the Common Vulnerability Scoring System (CVSS) ratings for the APARs. To obtain access to the portal, send an email to syszsec@us.ibm.com. The request is validated by the IBM account team. It requires your management approval and agreement to keep the information confidential. More information on z/OS Security and Integrity is available at

http://www.ibm.com/systems/z/solutions/security_subintegrity.html

Notification of HIPER and PE Critical Fixes

Being made aware of critical fixes is the first step to a successful preventive maintenance plan. IBM provides various notification methods to aid in this part of the process including HOLDDATA, PSP Buckets, and ServiceLink applications.

Enhanced HOLDDATA

IBM supplies a single source text file with information pertaining to critical fixes called Enhanced HOLDDATA. This one file encompasses all IBM z/OS platform products and is

updated daily. When the file is received, SMP/E ignores FMIDs that are not installed, so that HOLDDATA can be used on any system. The Enhanced HOLDDATA file is a reliable source for identifying HIPER and PE fixes that are available and comparing them to what is installed on the system when used as input to SMP/E. Security/Integrity HOLDDATA is available to authorized customers through the System z Security Portal.

▪ **ERROR**

IBM identifies HIPER and PE PTFs in an Enhanced HOLDDATA file with the ERROR construct.

```
++HOLD (JWSZ512) FMID (JWSZ512) REASON (BM11219) ERROR  
DATE (10094)  
COMMENT (SMRTDATA (FIX (UK55805) SYMP (FUL)  
CHGDT (100404) ) ) CLASS (HIPER) .  
++HOLD (UA43920) FMID (HDZ1A10) REASON (AA30909) ERROR  
DATE (10084)
```

The HOLDDATA provides information to identify the reason for the hold and the fixing PTF. For a PE APAR, the hold is against the PTF in error. The Enhanced HOLDDATA is received into the SMP/E global zone. The

SMP/E REPORT ERRSYSMODS

command can then be used on any target zone to identify missing critical service that applies to the system. The report lists the exception SYSMODs, the APAR numbers, the resolving SYSMODs that have not been installed yet, and the hold symptoms. This is an example of the output from REPORT ERRSYSMODS.

```

EXCEPTION SYSMOD REPORT FOR ZONE TZONE1

HOLD      SYSMOD  APAR      ---RESOLVING SYSMOD---  HOLD  HOLD
FMID      NAME    NUMBER    NAME      STATUS RECEIVED  CLASS  SYMPTOMS
-----
HBB7750  HBB7750  AA21480  UA43849  GOOD  YES      HIPER  FUL
          AA22164  UA42721  GOOD  YES      HIPER  FUL
          AA22176  UA42779  GOOD  YES      HIPER  FUL
          AA24575  UA41687  GOOD  YES      HIPER  PRF
          UA41948  HELD  YES
          AA24592  UA42246  GOOD  YES      HIPER  FUL
          UA45336  AA31404  UA52824  GOOD  YES      PE
          UA45370  AA29166  UA48054  GOOD  YES      PE

SMPPUNCH dataset has the SMP/E statements needed for APPLY processing.
SET BDY (TZONE1 ).
APPLY  SELECT (
    UA43849 /* PTF      RESOLVES AA21480 FOR HBB7750 FMID(HBB7750) */
    UA42721 /* PTF      RESOLVES AA22164 FOR HBB7750 FMID(HBB7750) */
    UA42779 /* PTF      RESOLVES AA22176 FOR HBB7750 FMID(HBB7750) */
    UA41687 /* PTF      RESOLVES AA24575 FOR HBB7750 FMID(HBB7750) */
/* UA41948  PTF      RESOLVES AA24575 FOR HBB7750 FMID(HBB7750) */
    UA42246 /* PTF      RESOLVES AA24592 FOR HBB7750 FMID(HBB7750) */
    UA52824 /* PTF      RESOLVES AA31404 FOR UA45336 FMID(HBB7750) */
    UA48054 /* PTF      RESOLVES AA29166 FOR UA45370 FMID(HBB7750) */
)
GROUP REDO.
    
```

▪ **FIXCAT**

In the Enhanced HOLDDATA file, a construct called FIXCAT is used to identify a function or product category that the PTF may be associated with. FIXCAT categorizes preventive maintenance to allow selectively choosing which service is applicable to your system and can be ordered. More information about the FIXCAT construct can be found in the SMP/E Reference manual. Here is an example of the Enhanced HOLDDATA with FIXCAT:

```

++HOLD(HRM7730) FIXCAT FMID(HRM7730) REASON(AA23971)
RESOLVER(UA40029)
CATEGORY(IBM.Coexistence.z/OS.V1R10)
DATE(08217)
++HOLD(HDZ1180) FIXCAT FMID(HDZ1180) REASON(AA16524)
RESOLVER(UA29601)
CATEGORY(IBM.Coexistence.z/OS.V1R10
IBM.Device.Tape.TotalStorageEnterpriseTape-3592,
IBM.Device.Tape.TS1120-3592, IBM.Device.Tape.TS1130-3592)
DATE(08217) .
    
```

More information about the z/OS Enhanced HOLDDATA, including downloading the latest data file, is available on the website: <http://service.software.ibm.com/holdata/390holddata.html>

PSP Bucket

A PSP (Preventive Service Planning) Bucket is an informational file created to help with the migration to a new release of z/OS and upgrading products and components that run on the z/OS platform. There are hardware and software PSP buckets that are updated daily, and include a list of HIPER APARs with available fixes, installation tips, and general information. PSP Buckets are categorized into upgrades and subsets. Upgrade represents the product release and subset represents an individual component within the release. For example, UPGRADE ZOSV1R11, SUBSET DFSMS™ contains all information pertaining to DFSMS Version 1, Release 11. You can search for and view PSP buckets at:
<http://www14.software.ibm.com/webapp/set2/psp/srchBroker>

ServiceLink using IBMLink

IBM provides methods of automatic notification of problems and fixes relating to IBM products through ServiceLink. The ASAP (Automatic Software Alert Process) application and the Alert for IBM eServer™ zSeries® application allow you to subscribe to IBM products of interest and receive electronic notification pertaining to critical software problems as they are identified.

Red Alert

Red Alert is another IBM method used to communicate extremely critical APARs that may affect the availability of a system. Red Alerts are published, in addition to an APAR being flagged HIPER, for a small number of exceptionally severe problems. There are no specific criteria for a Red Alert. Subscription services are available for Red Alerts through ServiceLink. More information on Red Alerts can be found at:
<http://www14.software.ibm.com/webapp/set2/sas/f/redAlerts/home.html>

IBM z/OS Preventive Service Deliverables

IBM has various resources for obtaining necessary fixes, including ShopzSeries and the automated SMP/E Internet Service Retrieval function.

ShopzSeries

ShopzSeries is a web application that you can use to obtain individual PTFs or service product packages. You can customize the ordering process by uploading reports from the z/OS host, which indicate the current service level and products installed on the host system. CBPDO (Custom Built Product Delivery Option) is available to order multiple IBM software products, up to a specified PUT level, all packaged on one tape or available for internet delivery. A PUT (Program Update Tape) level identifies when the PTF became available with sourceid PUTyymm.

ShopzSeries is available at: <http://www.ibm.com/software/shopzseries>

There are other preventive service fee offerings available through CustomPac®, including RefreshPac, which will deliver preventive maintenance through physical media. The

maintenance included on the deliverable is customized based on the SMP/E CSI dataset that is uploaded electronically. ROP (Refresh on Profile) is similar, except that the CSI is not required to be uploaded for each order, and based on the size of the order delivery may be using the internet or physical media. More information on CustomPac offerings is available at: <https://www.ibm.com/services/ca/en/custompac/>

SMP/E Internet Service Retrieval

SMP/E Internet Service Retrieval (available in z/OS release 1.7) is a one-step automated method to create and upload a service inventory file from your SMP/E CSI dataset, submit a service order, wait for the package to be ready, download the package electronically and processes the service package. The service order can be corrective service, naming specific APARs and PTFs. The service order can also be preventive service, requesting critical (HIPER, PE), recommended (RSUyymm) or all PTFs. The order might also be just for a two year file of Enhanced HOLDDATA without PTFs. The RECEIVE ORDER command accomplishes this task, and the process can be manually initiated or scheduled to complement your preventive service strategy. More information is available in the SMP/E User's Guide or <http://publibz.boulder.ibm.com/zoslib/pdf/smpeiret.pdf>

Recommended Service Upgrade (RSU) Preventive Maintenance Strategy

Installing maintenance across the z/OS platform can be a tedious task. Determining which maintenance is missing, which maintenance is important for the business, and which maintenance is essential for the system stability are complex decisions. IBM has developed the RSU Maintenance Strategy to make it more manageable and reliable. The RSU Maintenance Strategy also allows scheduling maintenance windows based on the predictable availability of RSU packages. RSU packages contain the IBM recommended maintenance needed to sustain high system availability. The prime objective of a Parallel Sysplex® is continuous availability. Installing and activating maintenance on one system at a time, referred to as rolling IPLs, is the recommended procedure in this environment.

IBM follows a rigorous testing sequence for all PTFs. There are specialized teams for each level of testing and every fix completes each phase of the testing cycle, including Unit and Regression Test prior to Consolidated Service Test (CST). CST is responsible for testing already available maintenance for z/OS and subsystems as a comprehensive system. Subsystems include DB2, IMS, CICS, WebSphere Application Server and MQ. This figure illustrates the testing sequence for PTFs. Note that CST testing is the last stage.

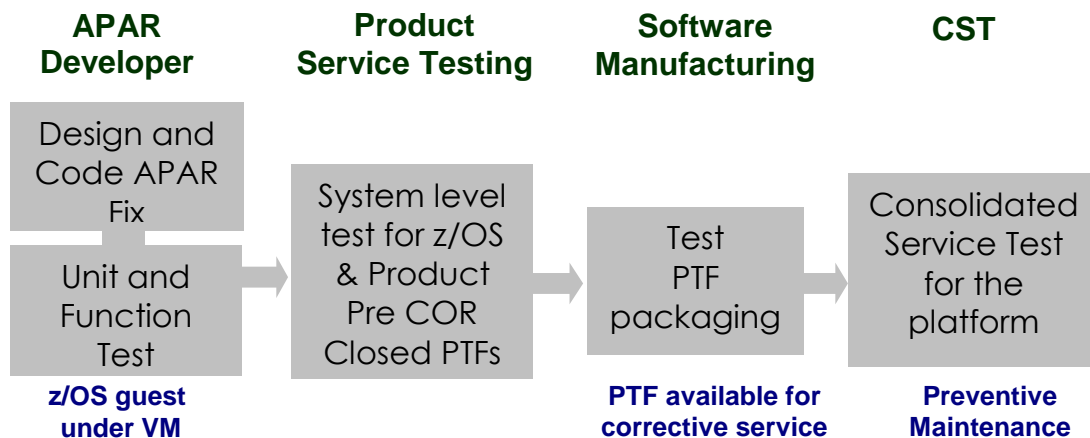

IBM testing sequence for PTFs

The CST team tests the RSU on the z/OS platform. The goal is to ensure that all products work well together and provide a complete end to end solution. The CST environment is designed as

a customer like production environment. Both online and batch workloads are active, and are steady state and stress tested, with specific testing for z/OS, CICS, IMS, WebSphere Application Server, DB2 and MQ. As an example, the CST environment below includes three levels of z/OS (current level n, n-1, n-2) and two levels of subsystems (current level n, n-1). There are two Parallel Sysplexes: Plex 1 is an 8-way with one 6-way and two 3-way datasharing groups. Plex 2 is a 9-way with one 3-way and two 4-way datasharing groups. A GDPS environment exists on both sysplexes. This figure illustrates the software and configuration of Plex 1 and Plex 2.

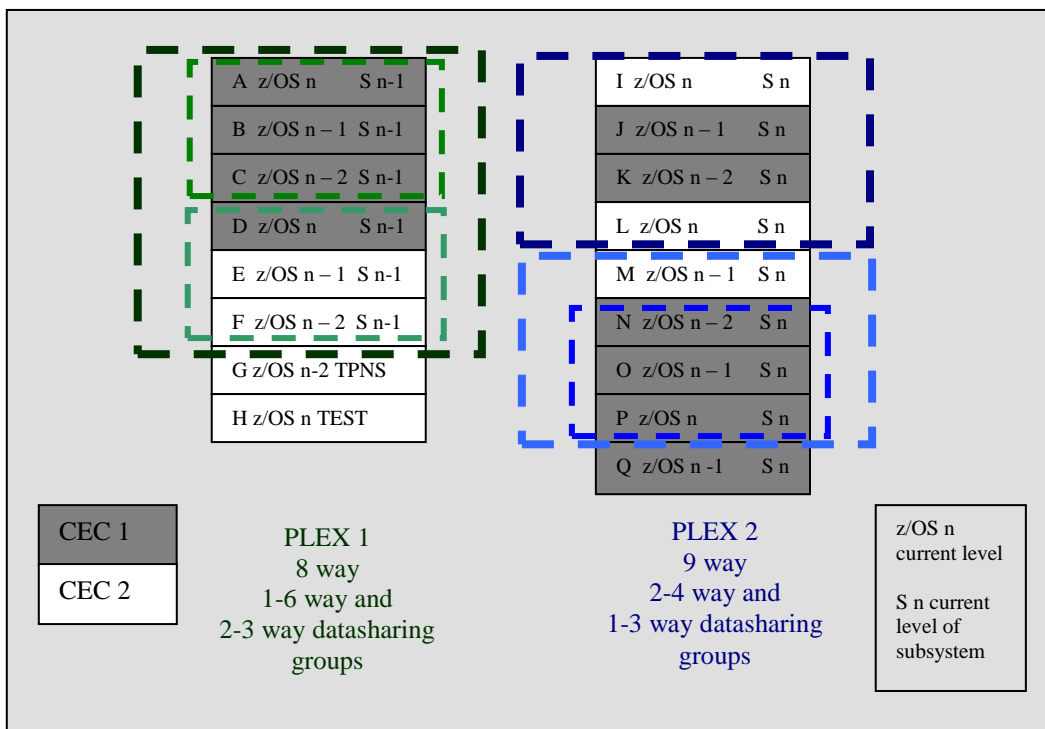

CST test systems Plex 1 and Plex 2

Current CST configuration information can be found in the CST quarterly report linked from the CST web page at <http://www.ibm.com/systems/z/os/zos/support/servicetest/>.

RSUs can be obtained through SMP/E Interent Service Retrieval as well as in service orders placed through Shopz and ServiceLink. The deliverables include ++ASSIGN statements that identify the RSU maintenance to be installed. The ++ASSIGN statements appear similar to the following example::

```
++ASSIGN SOURCEID(RSU1002) TO(UA46866) .  
++ASSIGN SOURCEID(RSU1002) TO(UA46868) .
```

The SOURCEID identifies the RSU ID in the form of RSUyymm. The SOURCEID is the date the service completed the CST test cycle and was recommended - it is **not** the date that the service became available. RSUs are available monthly in the first few days of the month, and are available in two cycles. **RSUs are not cumulative, therefore all RSUs must be installed.**

- **Quarterly RSUs** (yy03, yy06, yy09, yy12)
RSU service packages delivered each quarter include ALL maintenance that has been available as corrective service at the beginning of the prior quarter. The PTFs are added to the CST environment at the beginning of the quarter and tested for a full three months. For example, a severity 3 PTF is made available on July 16th. It is added to the CST environment on October 1st, tested for 3 months and made available on the RSU delivered in January (RSUyy12).
- **Monthly RSUs** (yy01, yy02, yy03, yy04 ...)
For those customers who prefer more regular and frequent service upgrades, a monthly RSU is available. It contains HIPER, PE, Security/Integrity and Pervasive fixes. The fixes are added to the CST environment on the first of the month and tested for one full month. The fix is then included on the next RSU released. For example, the corrective service for a HIPER APAR is made available on January 12th. The PTF is added to the CST environment on February 1st. It is then included on the RSU delivered in March (RSUyy02).

RSUs comprise maintenance from multiple products available on the z/OS platform, including CICS, IMS, DB2, WebSphere Application Server and MQ. Detailed information about CST is available at: <http://www.ibm.com/systems/z/os/zos/support/servicetest/>

General Suggestions for Maintenance Practices

It is suggested to upgrade two to four times per year to the latest RSU Preventive Maintenance that is available. HIPER and PE fixes should be reviewed weekly, and installed weekly or monthly if possible. HIPER fixes can be ordered and received for immediate installation if needed. Security/Integrity APARs and Red Alerts should also be monitored regularly.

Conclusion

The value of availability of a system varies depending on the user. However, any outage, even a small one, can impact the business as a whole. There are some effects that can be measured financially, such as loss of revenue and the cost of labor related to recovery from the outage. There are also effects that can be measured in other ways, including lost opportunity, business image, and unrecoverable productive time.

Maintaining availability of your z/OS system takes commitment and focus from key resources in the process. IBM is dedicated to provide the tools and foundations needed to service your z/OS system to the highest extent. RSU is the foremost preventive service resource available to meet the expectations of z/OS.

Websites of Interest

Description	URL
CST	www.ibm.com/systems/z/os/zos/support/servicetest/
CustomPac	www.ibm.com/services/ca/en/custompac/
FIXCAT	www.ibm.com/systems/z/os/zos/smpe/fixcategory.html
GDPS	www.ibm.com/systems/z/advantages/gdps/index.html
HOLDDATA	service.software.ibm.com/holddata/390holddata.html
Parallel Sysplex	www.ibm.com/systems/z/advantages/psol/
Red Alerts	www.software.ibm.com/webapp/set2/sas/f/redAlerts/home.html
ShopzSeries	www.ibm.com/software/shopzseries
SMP/E	www.ibm.com/systems/z/os/zos/smpe/
SMP/E Internet Service Retrieval	publibz.boulder.ibm.com/zoslib/pdf/smpeiret.pdf
z/OS Home Page	www.ibm.com/systems/z/os/zos/index.html
z/OS Support	www.ibm.com/systems/z/os/zos/support/
z/OS Security/Integrity	www.ibm.com/systems/z/solutions/security_subintegrity.html

z/OS Preventive Maintenance Strategy to Maintain System Availability

z/OS Preventive Maintenance Strategy to Maintain System Availability



Copyright IBM Corporation 2010

IBM Systems and Technology Group
Route 100
Somers, New York 10589
U.S.A.

Produced in the United States of America,
10/2010
All Rights Reserved

IBM, IBM eServer, IBM logo, CICS, CustomPac, DB2, DB2 Connect, DFSMS, GDPS, Geographically Dispersed Parallel Sysplex, HyperSwap, IMS, MQSeries, Parallel Sysplex, Resource Link, ServerPac, System z, WebSphere and z/OS are trademarks or registered trademarks of the International Business Machines Corporation.

Adobe, the Adobe logo, PostScript, and the PostScript logo are either registered trademarks or trademarks of Adobe Systems Incorporated in the United States, and/or other countries.

Cell Broadband Engine is a trademark of Sony Computer Entertainment, Inc. in the United States, other countries, or both and is used under license therefrom.

InfiniBand and InfiniBand Trade Association are registered trademarks of the InfiniBand Trade Association. Java and all Java-based trademarks are trademarks of Sun Microsystems, Inc. in the United States, other countries, or both.

Microsoft, Windows, Windows NT, and the Windows logo are trademarks of Microsoft Corporation in the United States, other countries, or both.

Intel, Intel logo, Intel Inside, Intel Inside logo, Intel Centrino, Intel Centrino logo, Celeron, Intel Xeon, Intel SpeedStep, Itanium, and Pentium are trademarks or registered trademarks of Intel Corporation or its subsidiaries in the United States and other countries.

UNIX is a registered trademark of The Open Group in the United States and other countries.

Linux is a registered trademark of Linus Torvalds in the United States, other countries, or both.

ITIL is a registered trademark, and a registered community trademark of the Office of Government Commerce, and is registered in the U.S. Patent and Trademark Office.

IT Infrastructure Library is a registered trademark of the Central Computer and Telecommunications Agency, which is now part of the Office of Government Commerce.

Notices

IBM provides information in this document to assist customers with planning a Preventive Maintenance process to help ensure the highest levels of availability. IBM does not guarantee the results.

All statements regarding IBM's future direction and intent are subject to change or withdrawal without notice and represent goals and objectives only.

ZSW03172-USEN-00