



*A Leading Provider of Multimedia
Communication Solutions*

RMA Problem Solving Manual

Version 1.0

2007/12/05

Problem Solving Manual

© 2008 VIVOTEK Inc. All Right Reserved

The following is trademarks of VIVOTEK Inc., and may be used to identify VIVOTEK products only: VIVOTEK. Other product and company names contained herein may be trademarks of their respective owners.

No part of this publication may be reproduced or utilized in any form or by any means, electronic or mechanical, including photocopying and microfilm, without permission in writing from VIVOTEK Inc.

Revision History

Version	Issue date	Editor	Comment
1.0	2007/12/11	Sandy/Albus	First draft

Index

INDEXBASIC TEST	3
BASIC TEST	5
1) <i>Restore Default Settings</i>	5
2) <i>PC And Camera Direct Connection</i>	6
3) <i>Access The Camera</i>	8
4) <i>Upgrade To The Latest Firmware</i>	10
PROBLEM CLASSIFICATION	14
PAN/TILT FAIL	14
UNCLEAR VIDEO	14
NO SIGNAL	16
WIRELESS	17
APPENDIX A	21
RX7101	21
PT7137.....	21
PT7135.....	21
IP7151/7152.....	22
IP7137.....	22
IP7135.....	22
FD7131	23
VS7100	23
VS3102	23
VS3100	24
VS2403	24
VS2402	25
VS2101	25
PZ61X4.....	26
PZ61X2.....	26
PT31X7.....	26
PT31X4.....	27
PT31X3.....	27
PT31X2.....	27
IP7139, IP7138.....	27
IP7132, IP7131.....	28

IP3137.....	28
IP3136.....	28
IP3135.....	29
IP3133.....	29
IP3132.....	29
IP61X7.....	29
IP61X4.....	30
IP61X2.....	30
IP31X2.....	30
IP31X1.....	31
IP21X2.....	31
IP21X1.....	31
FD61X2.....	32
FD61X1.....	32

Vivotek
confidential

Basic Test

If there are any VIVOTEK products, network cameras or the video servers, that can't work normally, please make sure the network cable and power adaptor work normally first and then follow the steps to verify their status.

If the problem remains after verified, please note how long and how to reproduce the problem on RMA form.

1) Restore Default Settings

1. Please restore the camera to default settings and check it again. Here is the restore method,

There is a button inside a hole on the case of the camera (varies from model to model) that is used to reset the system or restore to factory default settings. Sometimes resetting the system sets the system back to normal state. If the system problems remain after reset, please restore to factory default settings and install it again. Different models behave differently during restoring to default settings due to different LED lights.

Steps:

- (1) Find a probe (like a paper clip) to push the reset button inside the reset hole.
- (2) Hold the button down for a few seconds.
- (3) While you're holding down the button, the LED will perform POST (power-on-self-test).

Wait for the self-diagnostic to run twice.

(4) You can release the reset button and set up the camera by using the Installation Wizard again.

(5) For the films of restoring to default settings of each model, please visit the Q7 of the link and you will have more ideas in restoring:

http://www.vivotek.com/support/faq/faq_maintenance.html

2. Check the LED status during the process of restore to default settings, please refer to [Appendix A](#).
3. If the power adaptor and network devices, like Ethernet cable and hubs, works normally, but the LED status is abnormal, please contact rma@vivotek.com for VIVOTEK RMA Procedure.

2) PC And Camera Direct Connection

Connect the camera and PC directly (using a cross-over Ethernet cable or a hub), regarding using a hub to connect to the camera, please refer to the Fig. 1

- A. Check the LED status. Please refer to Table 2 LED Status. For example, IP7135, the red light should be steady and blue light should blink. If not, check your network devices.
- B. Restore the camera to factory default and refer to IP address table as below. Make sure there is no DHCP server in the system. (Such as the computer running Installation Wizard)

Table. 1

X, Y means one of the numbers, 0~255.

	IP	Subnet mask	Gateway
Default value for camera	192.168.0.99	255.255.255.0	192.168.0.1
Your PC could be	192.168.0.X	255.255.255.0	192.168.0.1
Your PC could also be	192.168.X.Y	255.255.0.0	192.168.X.1

- C. If your device belongs to 7000 series, please run Installation Wizard 2 to find their IP addresses, and you can discover them at least with the addresses, 169.254.X.Y. Double click on the listed IP addresses to access them.
- D. If your IP network settings are correct, and it is still impossible to find the camera in the list. Please contact rma@vivotek.com for VIVOTEK RMA Procedure.

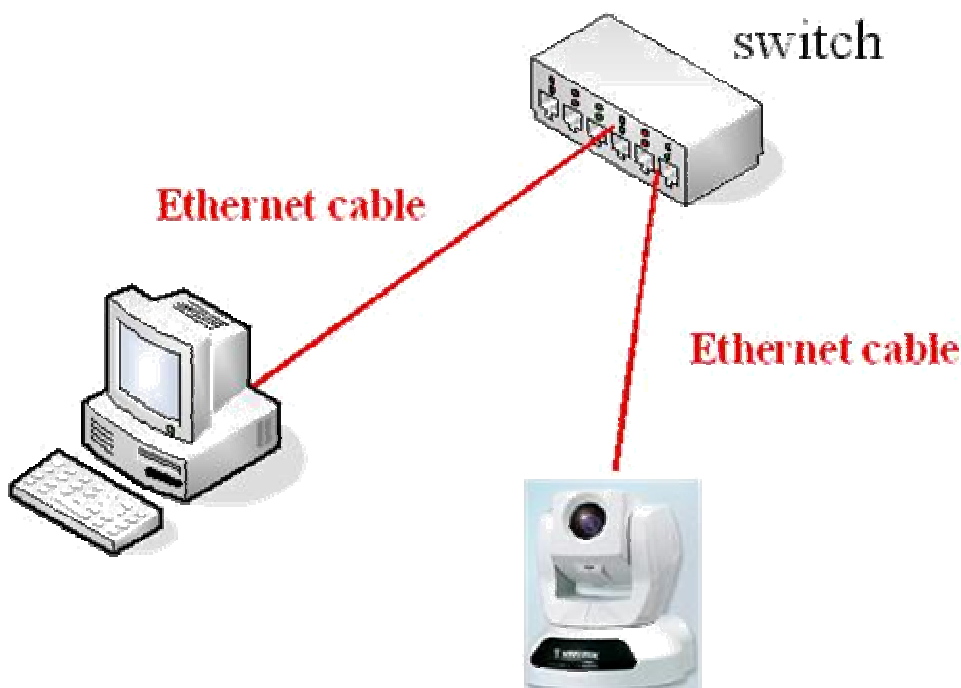

Fig. 1

Table. 2 LED Status

Camera model	LED status
IP21x1/ IP31x1	LED1 Red: blink LED2 Green: blink LED3 Green: steady
IP21x2	Green: blink
IP31x2	Green: blink
IP3133	Green: blink
IP3135/ IP3136/ IP3137	Blue: blink
IP7131/IP7132	Green/Orange: blink Red: steady
IP7135/ IP7137	Red: steady Blue: blink
IP7138/IP7139	Red: steady Green: blink
IP7151/IP7152	Green: blink
IP61x2	Green: blink
IP61x4	Green: blink
IP61x7	Green: blink
FD61x1V/ FD61x2V	Red: steady Green: blink
FD7131	Orange: blink Red: blink
PT31x2/ PT31x4 PT31x3/ PT31x7	Red: steady Green: blink
PT7135/ PT7137	Red: steady Blue: steady Green: blink
PZ61x2/ PZ61x4	Red: steady Green: blink
SD6112V/6121V	Red: steady Green: blink
VS2101	LED1 Red: blink LED2 Green: blink LED3 Green: off
VS2402/ VS2403	
	NET
	SYS

	LED1	Red: blink	Red: steady
	LED2	Green: steady	Green: blink
	LED3	Green: steady	Off
VS3100P	Green: blink		
VS3102	LED1: blink LED2: blink LED3: off		
VS7100	Green: blink Red: steady		
RX7101	Green: blink Red: steady		

3) Access The Camera

Invoke Installation Wizard 2, double click on the IP address to connect to the camera using I.E. You can download Installation Wizard 2 from the link and install the program.

<http://www.vivotek.com/downloadfiles/downloads/software/InstallationWizard2.zip>

You can search the camera IP addresses by the software like the Fig.2.

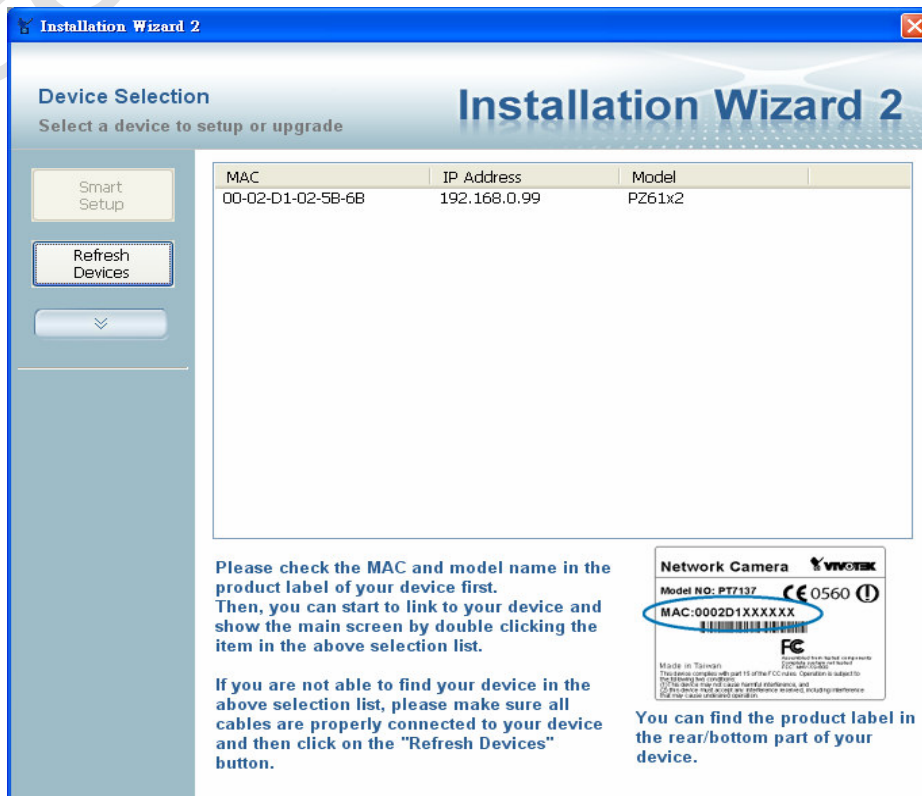

Fig. 2

If there is something wrong with the webpage (ex. the buttons are deployed wrong, the firmware version is displayed wrong), please delete the cookies and temporary files of your Internet Explorer.

A. IE6 as shown



B. IE7 as shown

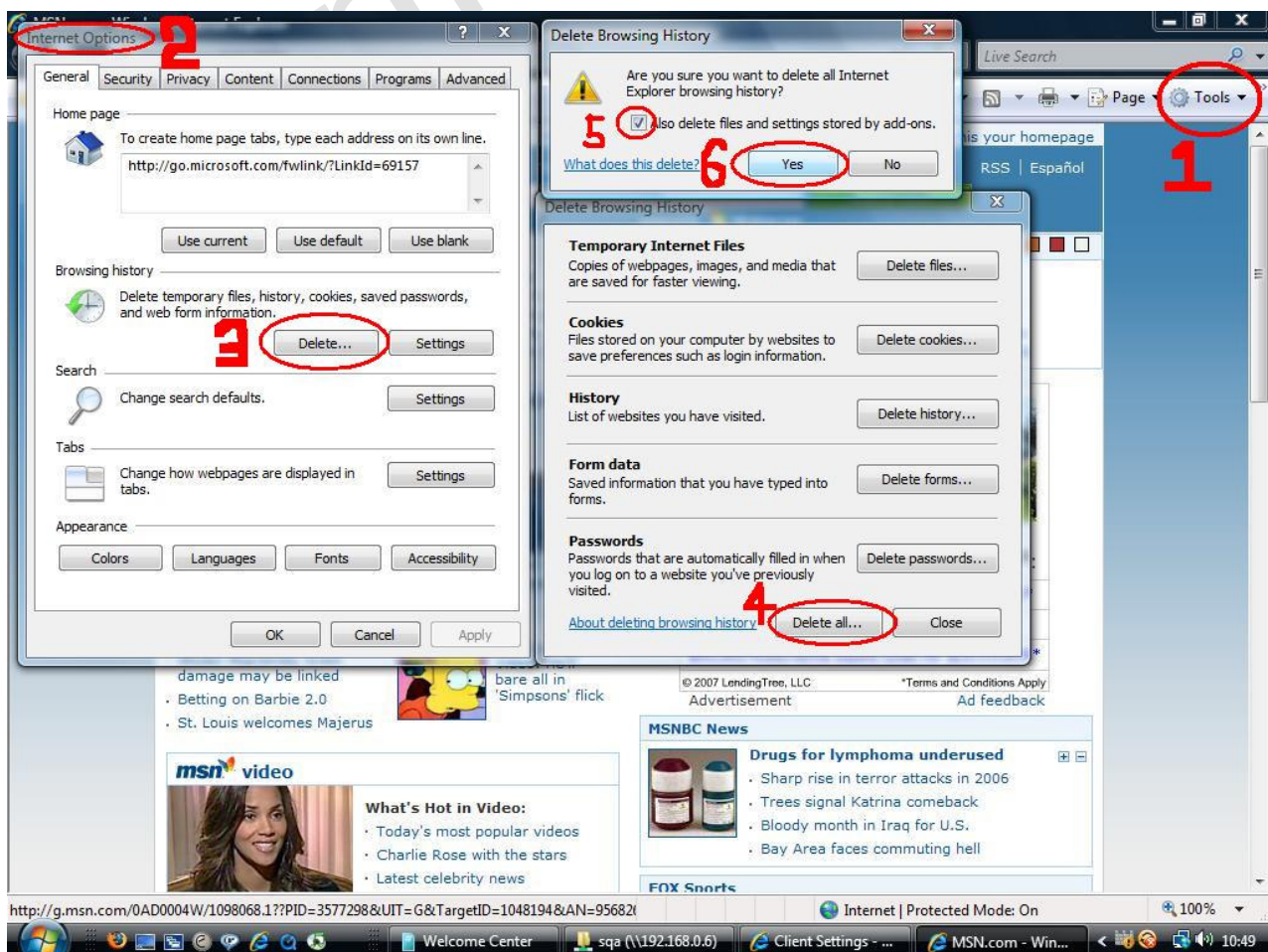

4) Upgrade To The Latest Firmware

- C. Please check the firmware version of the camera, make sure it is the latest version. You can download the latest firmware from VIVOTEK website.
(http://www.vivotek.com/downloads/firmware/firmware_fix_network_cameras.php)
- D. Please upgrade the firmware and try to connect to the camera again.
- E. If the problem remains the same. Please refer to the section of “Problem Classification”.

Here are methods to upgrade firmware:

A. Installation Wizard/ Installation Wizard 2

Step 0, Run “Installation Wizard” or “Installation Wizard 2”. Please note the serial number, it’s the MAC address of your device.

Step 1. Check the box in front of the IP address, the camera of the current selected IP address will be upgraded. (Fig.4)

Step 2, Click “Upgrade” button. You can upgrade the firmware of the same devices at the same time, multiple devices of the same model one time.

Fig. 5 indicates the upgrade process of multiple instances of the same model.

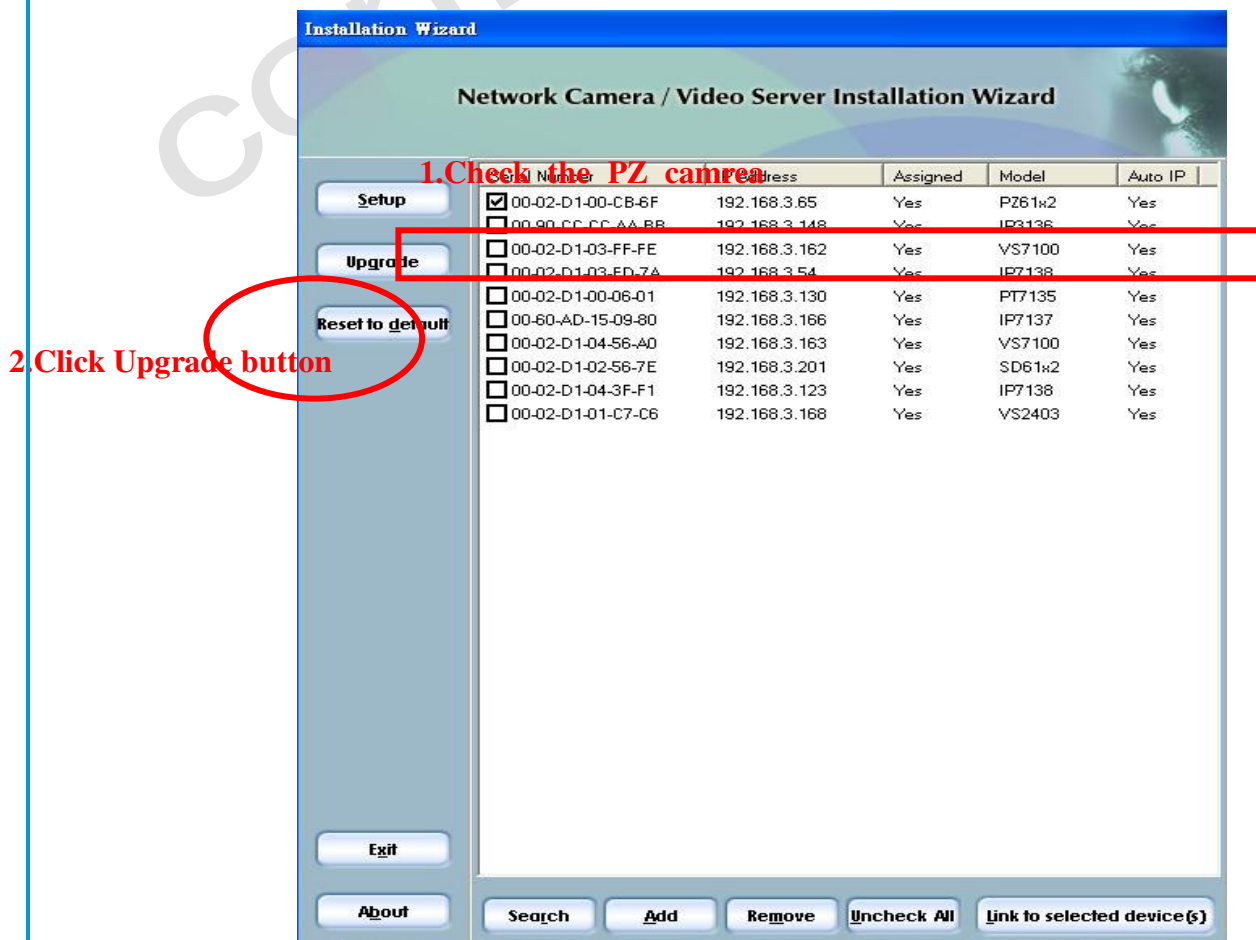

Fig. 3

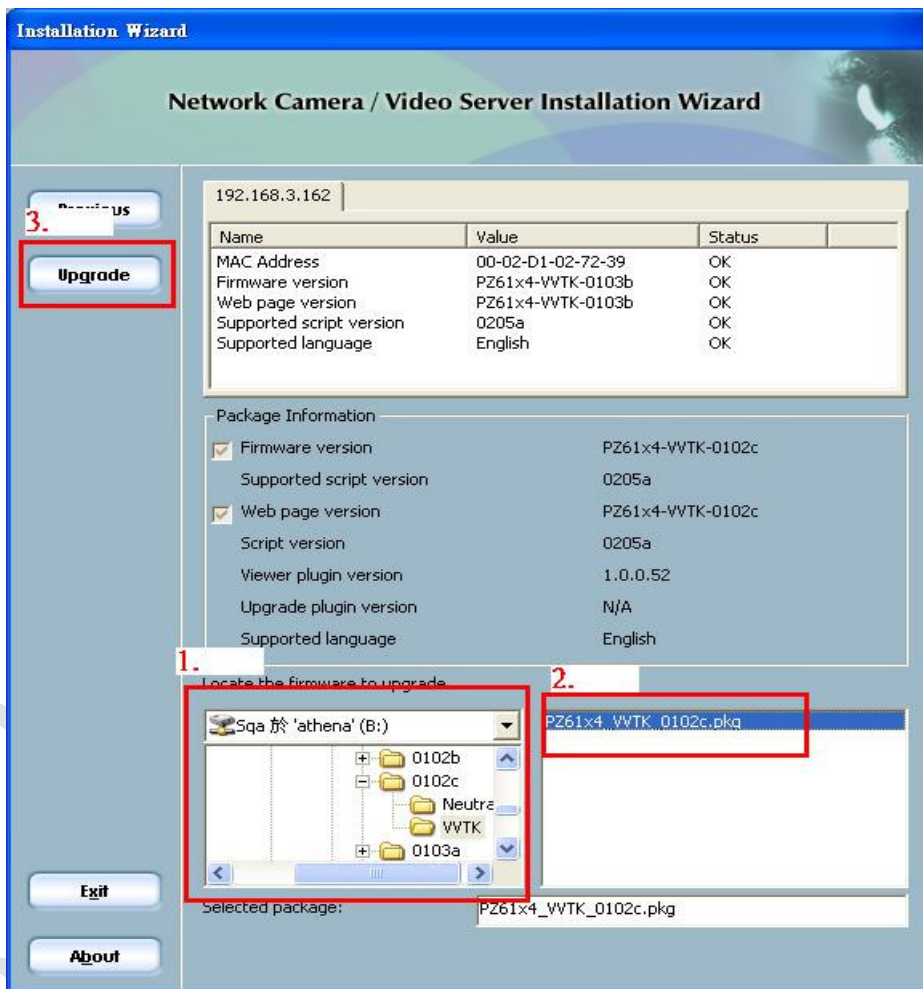

Fig. 4 Upgrade page

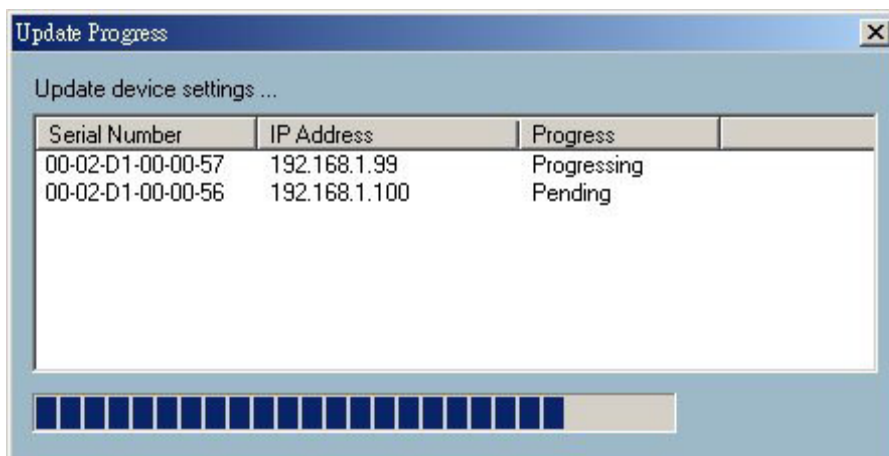

Fig. 5 Update progress

After the upgrade process is done, you can see the dialog below (Fig. 6). Click “Done” to finish.

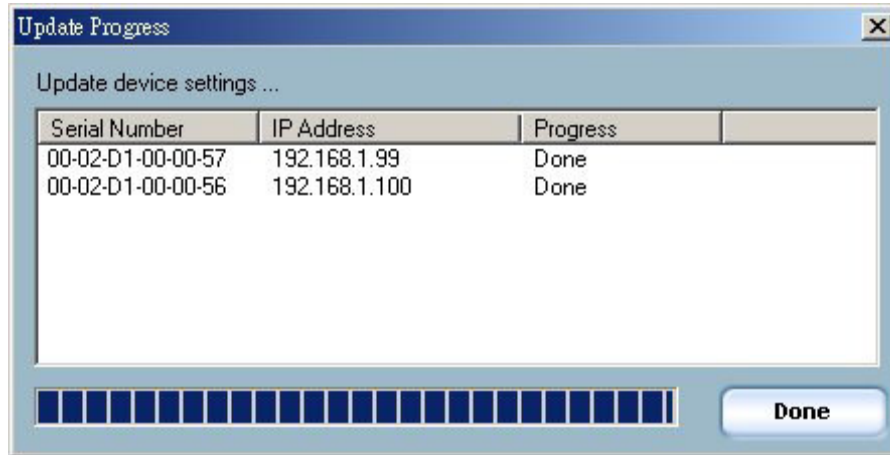

Fig. 6 Update progress

B. Maintenance

This way is only allowed for VIVOTEK 7000 series cameras. You can use the file list to browse the firmware file in the Maintenance page. Please check whether the file you selected is correct. Then click on the “Upgrade” button to upgrade the firmware. Please refer the Fig.7

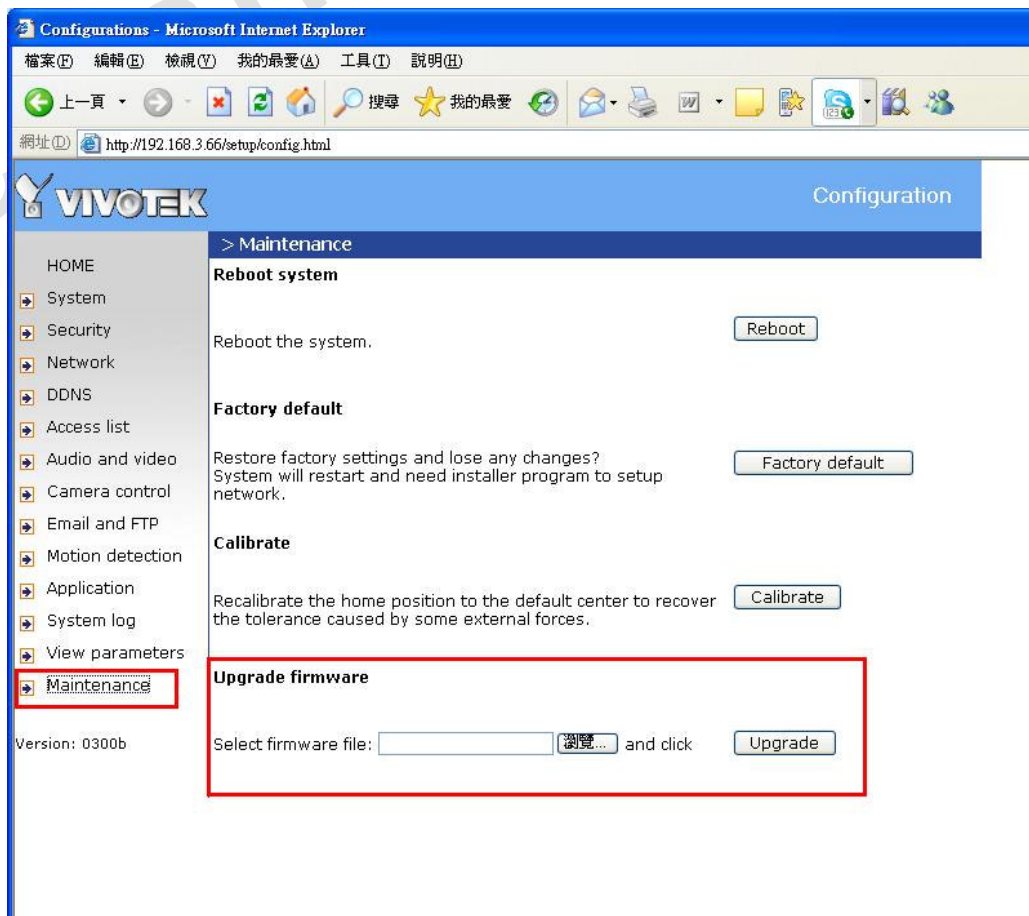
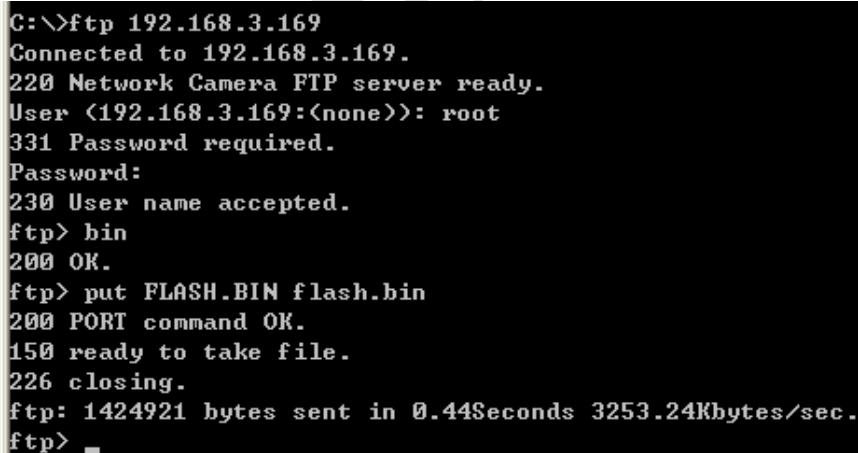

Fig. 7

C. FTP

Only “*.bin” firmware files can be upgraded via FTP utility. “*.pkg” files can not be upgraded via FTP utility. You can follow the steps,

1. Put the firmware (ex: flash.bin) in one specific folder.
2. Open command window, switch to the specific folder where you put the firmware.
3. Type “ftp 192.168.0.30” (The IP address of the device)
4. Type “root” for user name and then click “Enter” button.
5. Input password if there is. If there is no password, please click “Enter” button.
6. Type “bin”
7. Type “put <firmware file name> flash.bin” command, and wait for upgrade.
8. Upgrade the firmware may take a few minutes, please do not unplug the power and the Ethernet cable.
9. After the commands are issued, please wait for 15 minutes to make sure the camera firmware upgrade succeeded.
10. Type “bye” to exit.



```
C:\>ftp 192.168.3.169
Connected to 192.168.3.169.
220 Network Camera FTP server ready.
User (192.168.3.169:(none)): root
331 Password required.
Password:
230 User name accepted.
ftp> bin
200 OK.
ftp> put FLASH.BIN flash.bin
200 PORT command OK.
150 ready to take file.
226 closing.
ftp: 1424921 bytes sent in 0.44Seconds 3253.24Kbytes/sec.
ftp>
```

Fig. 8

Problem Classification

Pan/Tilt Fail

1. Connect to the P/T/Z camera and click left/right/up/down button.
2. Make sure camera head will move to the correct direction.
3. If your P/T/Z camera can work correctly, the issue doesn't relate to the breakdown of machinery. Please contact technical@vivotek.com for help.
4. If the P/T/Z camera can't move. Please contact rma@vivotek.com for VIVOTEK RMA Procedure.

Unclear Video

1. Please adjust the lens manually except for the PZ 6000 series and SD series camera.
2. If the camera video is still unclear. Please contact rma@vivotek.com for VIVOTEK RMA Procedure.

Table. 3

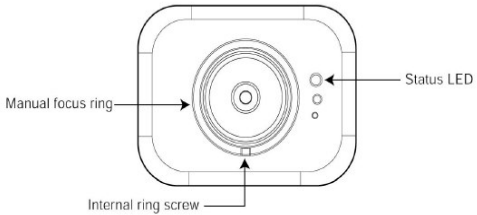
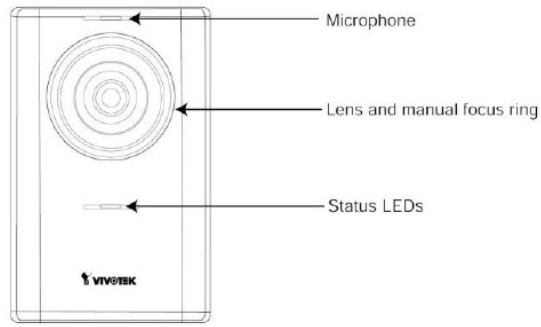
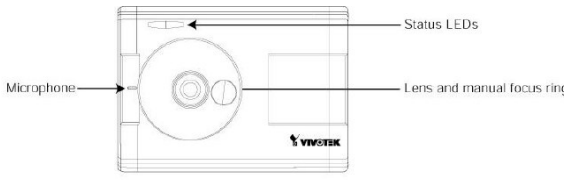
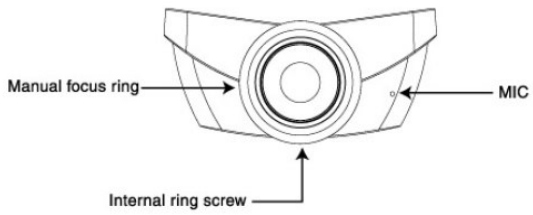
Model	Camera Sample	
IP Camera	 <p>Manual focus ring</p> <p>Status LED</p> <p>Internal ring screw</p>	 <p>Microphone</p> <p>Lens and manual focus ring</p> <p>Status LEDs</p>
	 <p>Microphone</p> <p>Status LEDs</p> <p>Lens and manual focus ring</p>	 <p>Manual focus ring</p> <p>Internal ring screw</p> <p>MIC</p>

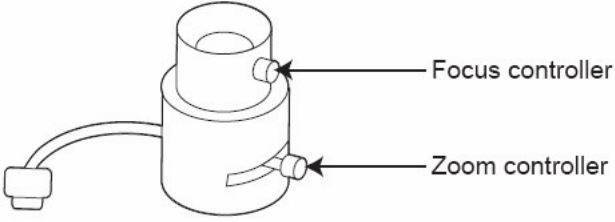
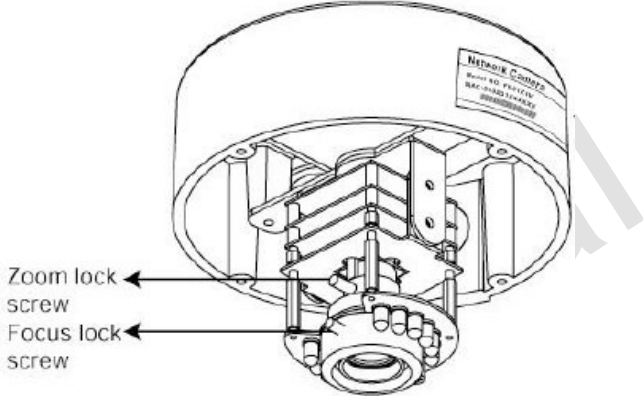
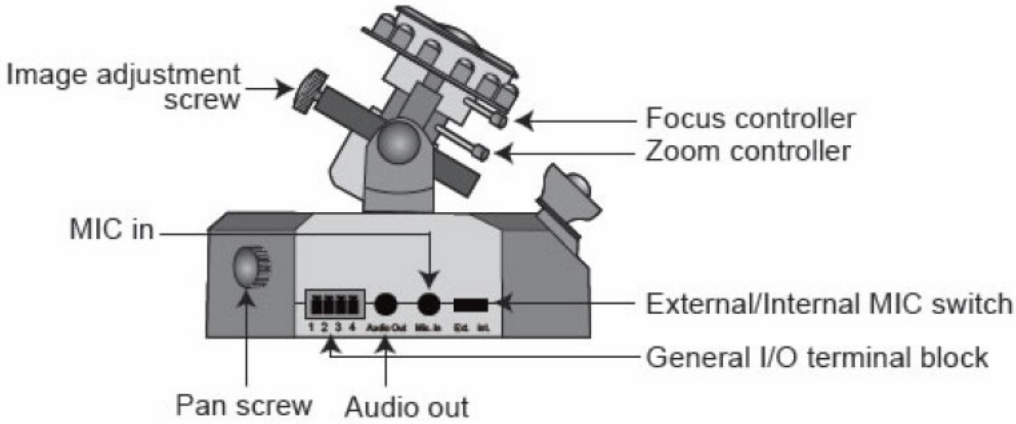
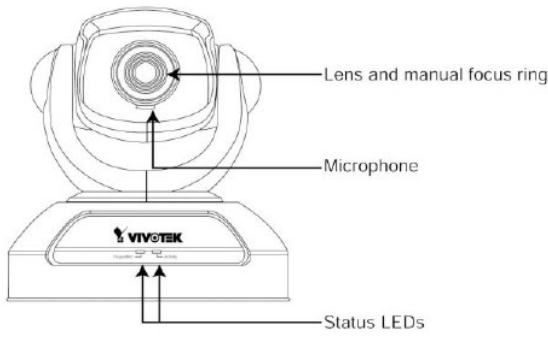
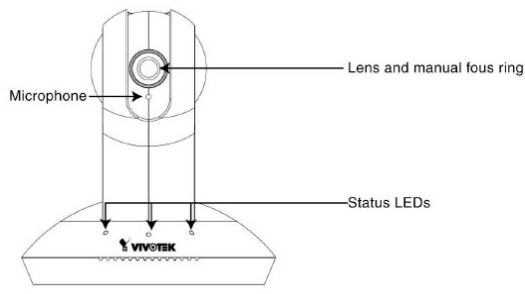
<p>IP7138/IP7139</p>	 <p>Focus controller</p> <p>Zoom controller</p>	
<p>FD 6000 series</p>	 <p>Zoom lock screw</p> <p>Focus lock screw</p>	
<p>FD7131</p>	 <p>Image adjustment screw</p> <p>MIC in</p> <p>Pan screw</p> <p>Audio out</p> <p>Focus controller</p> <p>Zoom controller</p> <p>External/Internal MIC switch</p> <p>General I/O terminal block</p>	
<p>PT Camera</p>	 <p>Lens and manual focus ring</p> <p>Microphone</p> <p>Status LEDs</p>	 <p>Lens and manual focus ring</p> <p>Microphone</p> <p>Status LEDs</p>

No Signal

1 “No Signal” is shown in the video.

1.1 If it is a Video Server, please check the CCD is OK or not;

1.2 If it is a network camera, please contact technical@vivotek.com for confirmation.

If the CCD is damaged, it might be the following status,

- You can see information of data and time.
- The camera can work correctly include the audio function except the image is wrong.
- The image might become black-and-white, or black or the hue is lost.

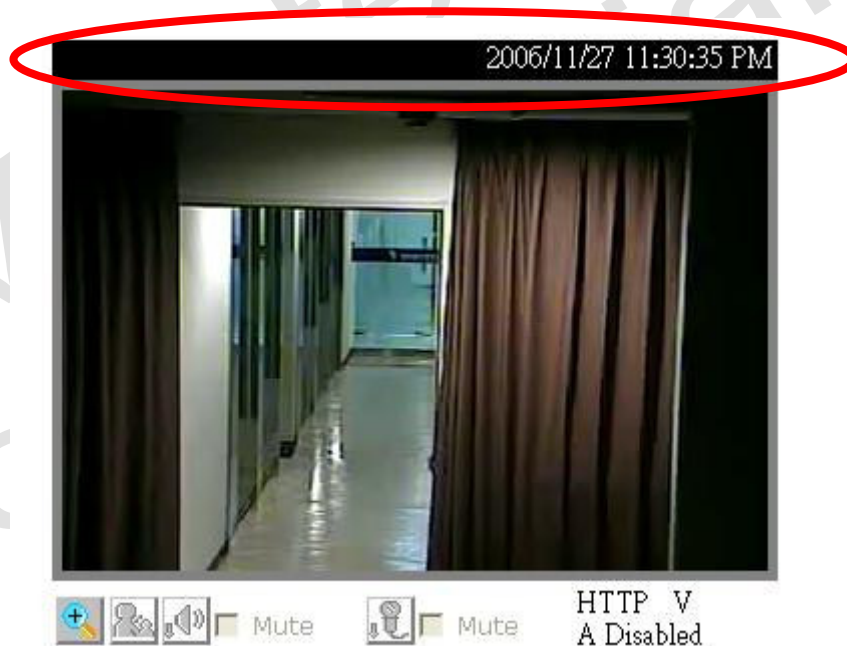

2 There is **status line**,

2.1 If it is a PZ camera, please try to open the IRIS to its maximum. If there is still problem, please try to open http://<ip_address>/index_iic.html for detail settings.

2.2 Make sure the stream you are requesting is not audio only.

2.3 Please contact technical@vivotek.com for help if neither cases match yours.

3 There is **no status line**, please check

3.1 Client mode

3.1.1 There are many modes of connections:

Camera series	Connection modes & ports required
2000	HTTP (HTTP port)
3000	UDP/TCP (HTTP/Video/Audio/Control ports); HTTP (HTTP port)
6000	UDP (HTTP/Video/Audio ports), HTTP (HTTP port)
7000	UDP (RTSP/RTP video/RTCP video/RTP audio/RTCP audio port);

TCP (RTSP port); HTTP (HTTP port); Multicast (LAN only)

3.2 NAT ports in the router; please check the ports listed in the previous table are opened for the Network Camera or Video Server. You can refer to the Q2 in our website http://www.Vivotek.com/support/faq/faq_network.html to know how to forward the ports on the router.

3.3 Try to use I.E. 5.5 or above versions, or contact technical@vivotek.com for help.

4 There is no plug-in installed in your computer like the following picture.

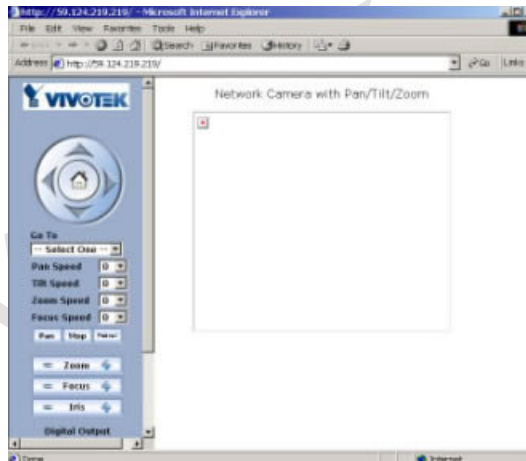

4.1 Please install Plug-in for viewing

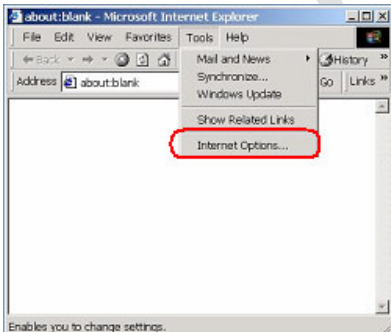

Steps

1. Click Tools/Internet Option

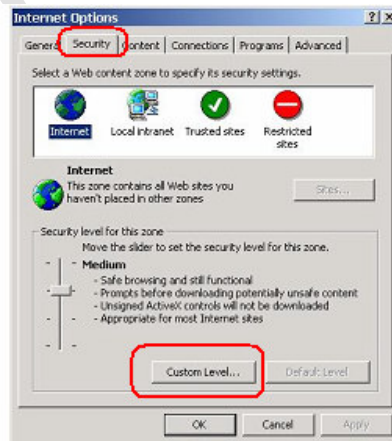

2. Select Security/Custom Level

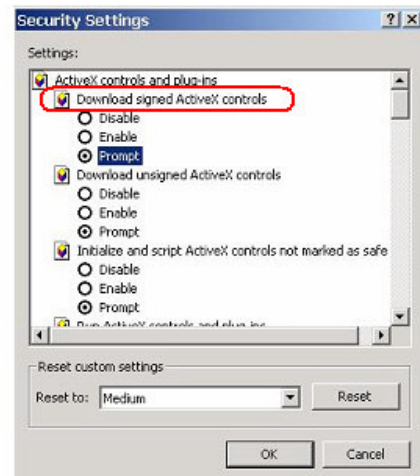

3. Select "Enable" or "Prompt"

Wireless

1. Please confirm the wireless settings of the camera and your AP. You can refer to the instruction as below, Remember different wireless router has different user interface and features,

First, you have to choose the "Infrastructure" mode for the wireless. The Ad-Hoc mode is used

for connect with your notebook or Wireless LAN Card.

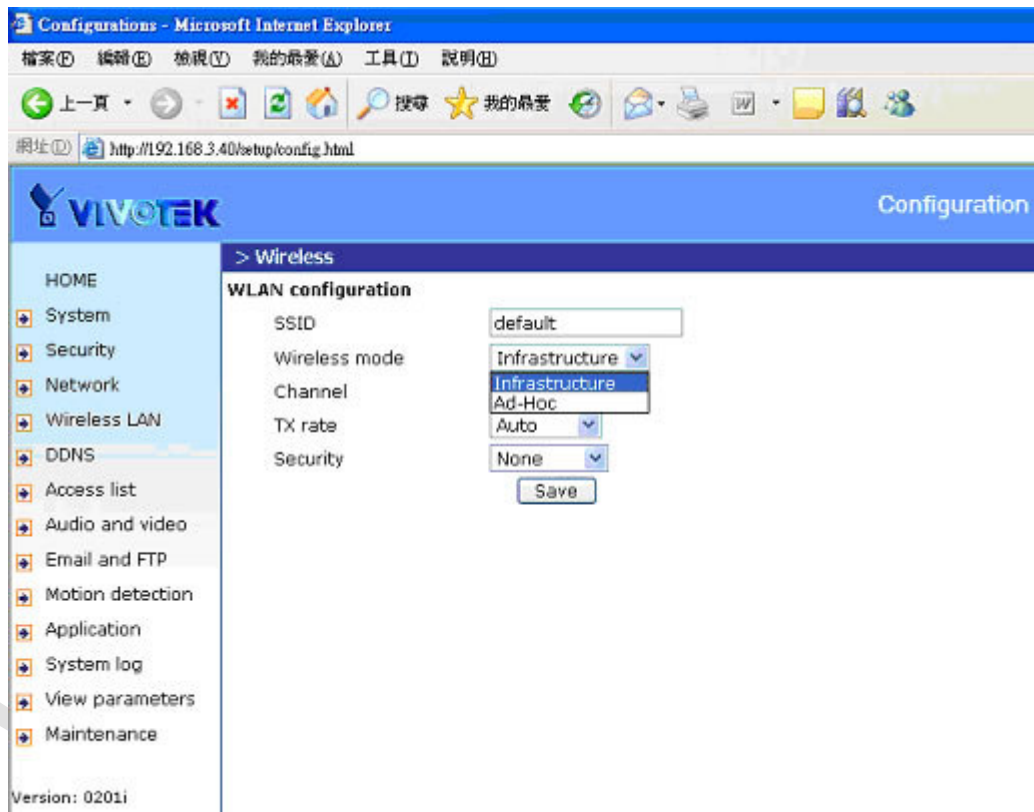

Second, check the SSID on your router and make sure the camera's SSID is the same as the router.



> Wireless

WLAN configuration

SSID:

Wireless mode:

Channel:

TX rate:

Security:

Third, choose “security mode” for your router and camera. There are WEP and WPA-Pre-Shared Key. If the router is using the WEP, you have to enter the key and set the size of the key. It can be 64-bit or 128bit. The 64-bit contain 10 Hexadecimal digits or 5 ASCII code. And the 128-bit keys contain 26 hexadecimal digits or 13 ASCII code. Please make sure the camera is using the same key as the router.

Setup	Wireless	Security	Access Restrictions	Applications & Gaming
Basic Wireless Settings	Wireless Security	Wireless MAC Filter		

Security Mode :

Default Transmit Key : 1 2 3 4

WEP Encryption :

Passphrase :

Key 1 :

Key 2 :

Key 3 :

Key 4 :

> Wireless

WLAN configuration

SSID:

Wireless mode:

Channel:

TX rate:

Security:

Auth mode:

Key length:

Key format:

Default key: 1 2 3 4

Network key:

WPA-Pre-Shared Key gives you a choice of two encryption methods, TKIP and AES. Select one from them and enter a password in the Pre-Shared key field with 8-32 characters.

Setup | **Wireless** | Security | Access Restrictions | Applications & Gaming

Basic Wireless Settings | Wireless Security | Wireless MAC Filter

Security Mode:

WPA Algorithms:

WPA Shared Key:

Group Key Renewal: seconds

> Wireless

WLAN configuration

SSID:

Wireless mode:

Channel:

TX rate:

Security:

Algorithm:

Pre-shared key:

- If the settings of camera and AP are correct and the connection still is failed, you can plug the power cable out and then plug it in again. That is in order to switch the connection mode to wireless .If the problem remains, please contact rma@vivotek.com for VIVOTEK RMA Procedure.

Appendix A

RX7101

Description	LED status
Power on and system booting	Steady Red
Power off	Red LED unlighted
Network works (heartbeat)	Steady Red + Blink Green every 1 sec.
Network fail	Steady Red + Green LED unlighted
UART control message	Steady Red + Blink Green every 0.15 sec.
Upgrading F/W	Blink Red every 0.15 sec. + Blink Green every 1 sec.
Restore default	Blink Red every 0.15 sec. + Blink Green every 0.15 sec.

PT7137

Condition	LED status
Loading system after power on	Steady red
During booting procedure	Steady green, blue and red
Detecting and setting network	Steady green and blue. Blink red till IP address is confirmed
After network is setup (system up)	Blink green every second and steady red
During the upgrade firmware process	Blink green every second and fast blink red
Enable audio	Steady blue. Disable audio will turn off blue LED.

PT7135

Condition	LED color
-----------	-----------

Loading system after power on	Steady red, blue, green
During booting procedure	Steady red, blue, green
Detecting and setting network	Steady green and blue. Blink red till physical network and IP address are confirmed.
After network is setup (system up)	Blink green every second and steady red
During the upgrade firmware process	Blink green every second and fast blink red
Enable audio	Steady blue. Disable audio will turn off blue LED.

IP7151/7152

Condition	LED color
Loading system after power on	Steady green and blink red (once)
During booting procedure	Blinking red
Detecting and setting network	Steady green till IP address is confirmed
After network is setup (system up)	Blinking green every other second and steady red
During the upgrade firmware process	Blink green / orange every second and fast blink red

IP7137

Condition	LED color
Loading system after power on	Steady blue
During booting procedure	Steady blue and red
Detecting and setting network	Steady blue and blink red till IP address is confirmed
After network is setup (system up)	Blink blue every second and steady red
During the upgrade firmware process	Blink blue every second and fast blink red

IP7135

Condition	LED color
Loading system after power on	Steady blue
During booting procedure	Steady blue and red

Detecting and setting network	Steady blue and blink red till IP address is confirmed
After network is setup (system up)	Blink blue every second and steady red
During the upgrade firmware process	Blink blue every second and fast blink red

FD7131

Condition	LED color
Loading system after power on	Blink green and orange (twice)
During booting procedure	Non light
Detecting and setting network	Steady orange till IP address is confirmed
After network is setup (system up)	Blink orange and red
During the upgrade firmware process	Rapidly blink orange till firmware is upgraded

VS7100

Condition	LED color
Loading system after power on	Blink green twice and steady red
During booting procedure	Steady green and red
After network is setup (system up)	Blink green every second and steady red
During the upgrade firmware process	Fast blink green and blink green every second







VS3102

Network Interface	Condition	LED2 (Heartbeat)	LED3 (Status)
Ethernet	before installed	OFF	OFF
	after installed	flash	OFF
	during camera control	flash	flash
PPP with modem	after POST	flash	ON
PPP with null modem	before connected	ON	ON
	after connected	flash	ON

VS3100

Condition	LED color
During self-diagnostic after power on	Blink in interchanged green and red
Ethernet signal is lost	Steady red till Ethernet is detected
Before network is setup	Steady green till IP address is confirmed
After network is setup	Blink green every second
Any hardware failure	Other patterns

VS2403

	NET	SYS	
Tx/Rx			Power
Link 10/100			LED1 (Heartbeat)
Full duplex			LED2 (Status)

Item	LED status	Description
Power-On-Self-Test	LED1 and LED2 blink alternately by 150ms	During the test
	LED1 blinks one time and LED2 blinks 3 times	TM1302 test fail
	LED1 blinks one time and LED2 blinks 4 times	RTL8100BL test fail
Network	LED1 off, LED2 off	Network fail
	LED1 blink every 0.5 second, LED2 off	Network normal, Heartbeat
Camera control	LED2 blink every 1 second	Get the control message

VS2402

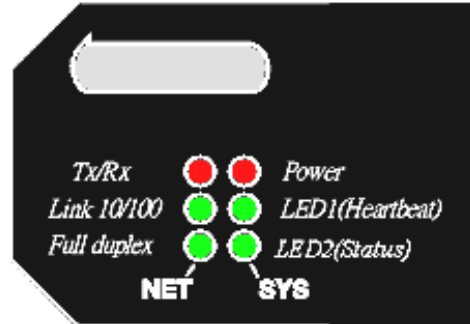

Network Interface	Condition	LED1 (Heartbeat)	LED2 (Status)
Ethernet	before IP installed	OFF	OFF
	after IP installed	Blink	OFF
	during camera control	Blink	Blink
PPP with modem	after POST	Blink	ON
	during camera control	Blink	Blink
PPP with null modem	before connected	ON	ON
	after connected	Blink	ON
	during camera control	Blink	Blink

VS2101

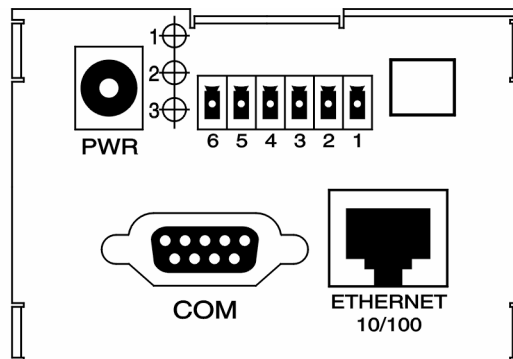

Network Interface	Condition	LED2 (Heartbeat)	LED3 (Status)
Ethernet	before installed	OFF	OFF

	after installed	flash	OFF
	during camera control	flash	flash
PPP with modem	after POST	flash	ON
	before connected	ON	ON
PPP with null modem	after connected	flash	ON
	before installed	OFF	OFF
	after installed	flash	OFF

PZ61X4

Condition	LED color
During self-diagnostic after power on	Blink in interchanged green and red
Ethernet signal is lost	Red LED is off till Ethernet is detected
Before network is setup	Steady green till IP address is confirmed
After network is setup	Blink green every second
Any hardware failure	Other patterns

PZ61X2

Condition	LED color
During self-diagnostic after power on	Blink in interchanged green and red
Ethernet signal is lost	Red LED is off till Ethernet is detected
Before network is setup	Steady green till IP address is confirmed
After network is setup	Blink green every second
Any hardware failure	Other patterns

PT31X7

Condition	LED color
During self-diagnostic after power on	Blink in interchanged green and red
Ethernet signal is lost	Red LED is blinking till Ethernet is detected
Before network is setup	Steady green till IP address is confirmed
After network is setup	Blink green every second
Any hardware failure	Other patterns

PT31X4

Condition	LED color
During self-diagnostic after power on	Blink in interchanged green and red
Ethernet signal is lost	Red LED is blinking till Ethernet is detected
Before network is setup	Steady green till IP address is confirmed
After network is setup	Blink green every second
Any hardware failure	Other patterns

PT31X3

Condition	LED color
During self-diagnostic after power on	Blink in interchanged green and red
Ethernet signal is lost	Red LED is blinking till Ethernet is detected
Before network is setup	Steady green till IP address is confirmed
After network is setup	Blink green every second
Any hardware failure	Other patterns

PT31X2

Condition	LED color
During self-diagnostic after power on	Blink in interchanged green and red
Ethernet signal is lost	Red LED is blinking till Ethernet is detected
Before network is setup	Steady green till IP address is confirmed
After network is setup	Blink green every second
Any hardware failure	Other patterns

IP7139, IP7138

Condition	LED color
Loading system after power on	Steady green and blink red (once)
During booting procedure	Steady green
Detecting and setting network	Steady orange (green + red) till IP address is confirmed

After network is setup (system up)	Blink green / orange every second and steady red
During the upgrade firmware process	Blink green / orange every second and fast blink red

IP7132, IP7131

Condition	LED color
Power is being supplied to the camera	Blinking red
The camera is booting up	Solid green
The camera is trying to obtain an IP address	Solid green with blinking red in between
An IP address is successfully assigned to the camera	Solid green and red
The camera is working	Solid red with blinking green in between
During firmware upgrading	Blinking red and green

IP3137

Condition	LED color
During self-diagnostic after power on	Blink in interchanged blue and red
Ethernet signal is lost	Steady red till Ethernet is detected
Before network is setup	Steady blue till IP address is confirmed
After network is setup	Blink blue every second
Network is setup and audio is disabled	Blink blue every 4 seconds
Any hardware failure	Other patterns

IP3136

Condition	LED color
During self-diagnostic after power on	Blink in interchanged green and red
Ethernet signal is lost	Steady red till Ethernet is detected
Before network is setup	Steady green till IP address is confirmed
After network is setup	Blink green every second
Network is setup and audio is disabled	Blink green every 4 seconds
Any hardware failure	Other patterns

IP3135

Condition	LED color
During self-diagnostic after power on	Blink in interchanged green and red
Ethernet signal is lost	Steady red till Ethernet is detected
Before network is setup	Steady green till IP address is confirmed
After network is setup	Blink green every second
Network is setup and audio is disabled	Blink green every 4 seconds
Any hardware failure	Other patterns

IP3133

Condition	LED color
During self-diagnostic after power on	Blink in interchanged green and red
Ethernet signal is lost	Steady red till Ethernet is detected
Before network is setup	Steady green till IP address is confirmed
After network is setup	Blink green every second
Any hardware failure	Other patterns

IP3132

Condition	LED color
During self-diagnostic after power on	Blink in interchanged green and red
Ethernet signal is lost	Steady red till Ethernet is detected
Before network is setup	Steady green till IP address is confirmed
After network is setup	Blink green every second
Any hardware failure	Other patterns

IP61X7

Condition	LED color
During self-diagnostic after power on	blink between red and green
No network	Red is ON

Getting IP	Green is flash every 0.5 sec
Talk only / mute	Green is flash every 1 sec
Listen only / Full duplex / half duplex	Green is flash every 0.5 sec

IP61X4

Condition	LED color
During self-diagnostic after power on	Red is no bright
No network	Red is ON
Getting IP	Green is flash every 0.5 sec
Talk only / mute	Green is flash every 1 sec
Listen only / Full duplex / half duplex	Green is flash every 0.5 sec

IP61X2

Condition	LED color
During self-diagnostic after power on	Blink between red and green
No network	Red is ON
Getting IP	Green is flash every 0.5 sec
Talk only / mute	Green is flash every 1 sec
Listen only / Full duplex / half duplex	Green is flash every 0.5 sec

IP31X2

Condition	LED color
During self-diagnostic after power on	Blink in interchanged green and red
Ethernet signal is lost	Steady red till Ethernet is detected
Before network is setup	Steady green till IP address is confirmed
After network is setup	Blink green every second
Any hardware failure	Other patterns

IP31X1

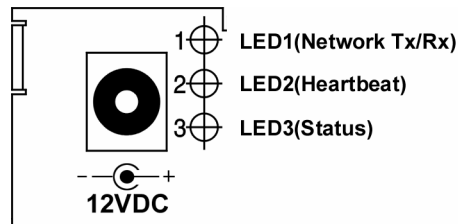

Network Interface	Condition	LED2 (Heartbeat)	LED3 (Status)
Ethernet	before installed	OFF	OFF
	after installed	flash	OFF
	during camera control	flash	flash
PPP with modem	after POST	flash	ON
PPP with null modem	before connected	ON	ON
	after connected	flash	ON

IP21X2

Condition	LED color
During self-diagnostic after power on	Blink in interchanged green and red
Ethernet signal is lost	Steady red till Ethernet is detected
Before network is setup	No LED of sign till IP address is set
After network is setup	Blink green once per second
Any hardware failure	Other patterns

IP21X1

Network Interface	Condition	LED2 (Heartbeat)	LED3 (Status)
Ethernet	before installed	OFF	OFF
	after installed	flash	OFF
	during camera control	flash	flash
PPP with modem	after POST	flash	ON
	before connected	ON	ON
PPP with null modem	after connected	flash	ON

	before installed	OFF	OFF
	after installed	flash	OFF

FD61X2

Condition	LED color
During self-diagnostic after power on	Blinking in interchanged Green and Red
After power on and before network is setup	Red LED is constantly ON and Green LED is OFF
After network is setup	Red LED is constantly ON and Green LED blinking every 0.5 second
Ethernet signal is lost	Red LED is constantly ON and Green LED is OFF
No audio or speak only	Red LED is constantly ON and Green LED blinking every second

FD61X1

Condition	LED Color
During self-diagnostic after power on	Blinking in interchanged Green and Red
After power on and before network is setup	Red LED is constantly ON and Green LED is OFF
After network is setup	Red LED is constantly ON and Green LED blinking every 0.5 second
Ethernet signal is lost	Red LED is constantly ON and Green LED is OFF
No audio or speak only	Red LED is constantly ON and Green LED blinking every second