

# Special Relativity

A Wikibook

[http://en.wikibooks.org/wiki/Special\\_relativity](http://en.wikibooks.org/wiki/Special_relativity)



**Part 1: Introductory text**

Cover picture: Albert Einstein and Hendrik Lorentz photographed by Ehrenfest (1880-1933) in front of his home in Leiden in 1921. Source: Museum Boerhaave, Leiden

# Table of Contents

Introduction.....	4
Intended Audience.....	8
What's so special?.....	8
Common Pitfalls in Relativity.....	9
A Word about Wiki.....	9
The principle of relativity.....	10
Frames of reference, events and transformations.....	10
Special relativity.....	12
The postulates of special relativity.....	13
The spacetime interpretation of special relativity.....	14
Spacetime.....	21
The lightcone.....	22
The Lorentz transformation equations.....	24
More about the relativity of simultaneity and the Andromeda paradox.....	26
The nature of length contraction.....	28
Evidence for length contraction, the field of an infinite straight current.....	30
De Broglie waves.....	32
More about time dilation.....	33
The twin paradox.....	34
Jim and Bill's view of the journey.....	37
The Pole-barn paradox.....	40
Addition of velocities.....	42
Relativistic Dynamics.....	45
Momentum.....	45
Force.....	50
Energy.....	50
Nuclear Energy.....	52
Light propagation and the aether.....	55
The aether drag hypothesis.....	55
The Michelson-Morley experiment.....	59
Measuring aether.....	60
The experiments.....	61
The most famous failed experiment.....	62
Fallout.....	64
Mathematical analysis of the Michelson Morley Experiment.....	65
Coherence length.....	69
Lorentz-Fitzgerald Contraction Hypothesis.....	70
External links.....	70
Appendix 1.....	71
Mathematics of the Lorentz Transformation Equations.....	71

# Introduction

The Special Theory of Relativity is a physical theory that was developed at the end of the nineteenth century and the beginning of the twentieth century. It replaced older theories such as Newtonian Physics and led to early Quantum Theory and General Relativity.

Special Relativity begins by re-examining the basis of Newtonian Physics. In Special Relativity it is shown that the Newtonian treatment of relative motion is incorrect and that the whole of physics must be rebuilt to account for this problem.



*Jim, dog and bus*

The following example serves to introduce the importance of relative motion when observing the world. Jim is standing on the street corner looking at a nearby stationary dog. Bob rides by on a bus. Jim and Bob both use various pieces scientific equipment to measure the apparent velocity of the dog. From everyday experience you should already be able to determine the results. Bob, seeing the dog on the street move by, determines that the dog is moving at the same speed as the bus. Jim on the other hand, determines that the dog is not moving at all.

The results obtained by Jim and Bob are different, but they make perfect sense. Jim and Bob are in different frames of reference. It seems that velocity measurements depend greatly on the frame of reference from which one takes the measurements. As we shall see, measurements of things we often take for granted, like time and space, *also* depend on the frame of reference.

The question we now ask is, "Which frame of reference is better, Jim's or Bob's?" Some would immediately say that performing measurements of distant objects from a moving bus is impractical, and anything so serious must be done while standing still. Unfortunately it is often the case that we don't have such a stationary frame of reference at our disposal.

When measuring the motion of distant planets the measurements must be performed on Earth, a moving planet in itself. In fact the Earth is behaving much worse than a bus; it is rotating and falling through space in an elliptical path! In such a case one may insist that all recorded data is transformed to the Sun's frame of reference, thereby defining the Sun as stationary. Then it is easier to conceptualize the nature of our solar system. But isn't the Sun also moving with respect to the other stars and the universe in general?

Indeed one may consider many ways to orient a frame of reference in the universe. But the question still remains, "Which is better?" This question bothered many scientists in the late

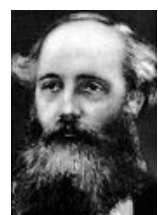

*Maxwell*

19th century when Maxwell's new theory of electromagnetism produced a number for the speed of electromagnetic wave propagation in vacuum (speed of light) but with no indication of the frame of reference. Some postulated that the speed would be measured with respect to "the one true frame." That is, that frame where the cosmic aether (the mysterious material permeating all space through which light waves move) is at rest.

After Michelson and Morley's famous experiment showed no indication that such a thing existed, and that the speed of light seemed to be the same in all available frames of reference, it was suggested that *there is no true frame*. That is, all reference frames are equally true and valid from the perspective of physics. In other words neither Jim's nor Bob's frame is closer to the natural frame than the other, because such a frame doesn't exist.

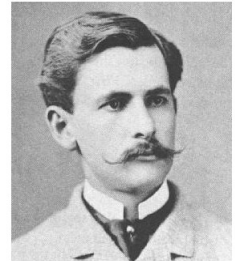

*Albert Abraham  
Michelson*

Special Relativity built on this premise. As a result, the universe suddenly became much more bizarre than previously suspected. Clocks slowed down, twins were no longer the same age, trains shrunk as they went by, and two people's perceptions of "right now" no longer seemed to correlate. For many people these developments were stranger facts than fiction!

This book will show you how the simple assumptions of Special Relativity imply these strange effects exist, and how to calculate the magnitude of such effects so as to prepare for them in the real world. It also attempts to explain the huge conceptual breakthrough that occurred in scientific thought a century ago.

## Historical Development

In the nineteenth century the idea that light was propagated in a medium called the "aether" was prevalent. James Clerk Maxwell in 1865 produced a theory of electromagnetic waves that initially seemed to be based on this aether concept. The theory was highly successful but it predicted that the velocity of electromagnetic waves would depend on two constant factors, the permittivity and permeability constants. Initially these constants were interpreted as properties of the aether. They would be the same for all observers so even in Maxwell's paper there was an implicit idea of a universal, stationary aether. Observers would measure the velocity of light to be the sum of their velocity and the velocity of light in the aether.

In 1887 Michelson and Morley performed an experiment that showed that the speed of light was independent of the speed of the destination or source of the light in the proposed aether. It seemed that Maxwell's theory

was correct but the theory about the way that velocities add together (known as Galilean Relativity) was wrong.

Various physicists attempted to explain the Michelson and Morley experiment. George Fitzgerald in 1889 and Hendrik Lorentz in 1895 suggested that objects tend to contract along the direction of motion relative to the aether. In 1897 Joseph Larmor and in 1899 Hendrik Lorentz proposed that moving objects are contracted and that moving clocks run slow. Fitzgerald, Larmor and Lorentz's contributions to the analysis of light propagation are of huge importance because they produced the Lorentz Transformation which is the mathematical equation required to explain how Maxwell's Equations might take precedence over the addition of velocities specified by Galilean Relativity. If the aether caused lengths to contract and clocks to run slow then, because velocity is just a ratio of length to time, velocities would no longer need to add up in a simple fashion and the speed of light could be constant for all observers.

By the late nineteenth century it was becoming clear that aether theories of light propagation were problematical. Any aether would have properties such as being massless, incompressible, entirely transparent, continuous, devoid of viscosity and nearly infinitely rigid. In 1905 Albert Einstein realised that Maxwell's equations did not require an aether. He proposed that the laws of physics are the same for all inertial frames of reference and that Maxwell's Equations were correct so that the "speed of light" is a constant for all observers.

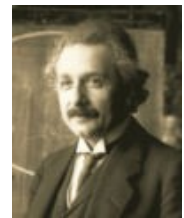

*Einstein*

On the basis of these simple assumptions he was able to derive the Lorentz Transformation. He showed that the Lorentz Transformation itself was sufficient to explain how length contraction occurs and clocks appear to go slow. Einstein's remarkable achievement was to be the first physicist to show some understanding of the geometrical implications of the Lorentz Transformation.



*Hermann  
Minkowski*

In 1905 Einstein was on the edge of the idea that made relativity special. It remained for the mathematician Hermann Minkowski to provide the full explanation of why an aether was entirely superfluous. He announced the modern form of Special Relativity theory in an address delivered at the 80th Assembly of German Natural Scientists and Physicians on September 21, 1908. The consequences of the new theory were radical, as Minkowski put it:

**"The views of space and time which I wish to lay before you have sprung from the soil of experimental physics, and therein lies their strength. They are radical. Henceforth space by itself, and time by itself, are doomed to fade away into mere shadows, and only a kind of union of the two will preserve an independent reality."**

What Minkowski had spotted was that Einstein's theory was actually related to the theories in differential geometry that had been developed by mathematicians during the nineteenth century. Initially Minkowski's discovery was unpopular with many physicists including Poincare, Lorentz and even Einstein. Physicists had become used to a thoroughly materialist approach to nature in which lumps of matter were thought to bounce

off each other and the only events of any importance were those occurring at the universal instantaneous present moment. The idea that the geometry of the world might include time as well as space was an alien idea. The possibility that phenomena such as length contraction could be due to the physical effects of spacetime geometry rather than the increase or decrease of forces between objects was as unexpected for physicists in 1908 as it is for the modern high school student. Einstein rapidly assimilated the new "physicalism" and went on to develop General Relativity as a theory based on differential geometry but many of the earlier generation of physicists were unable to accept the new way of looking at the world.

The adoption of differential geometry as one of the foundations of relativity theory has been traced by Walker (1999) and by the 1920's it had become the principle theoretical approach to relativity.

It has become popular to credit Henri Poincaré with the discovery of the theory of Special Relativity, sadly Poincaré got many of the right answers for all the wrong reasons. He even came up with a version of  $E = mc^2$ ! In 1904 Poincaré had gone as far as to enunciate the "principle of relativity" in which "The laws of physical phenomena must be the same, whether for a fixed observer, as also for one dragged in a motion of uniform translation, so that we do not and cannot have any means to discern whether or not we are dragged in a such motion." In 1905 Poincaré coined the term "Lorentz Transformation" for the equation that

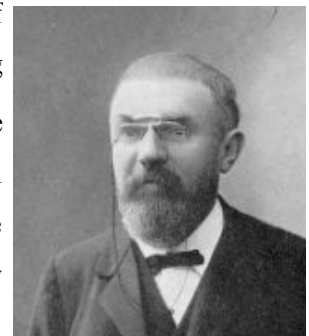

*Henri Poincare*

explained the null result of the Michelson Morley experiment. Although Poincaré derived equations to explain the null result of the Michelson Morley experiment his assumptions were still based upon an aether. It remained for Einstein to show that that an aether was unnecessary, a conceptual leap that thwarts many students even today.

It is also popular to claim that Special Relativity and aether theories such as those due to Poincaré and Lorentz are equivalent and only separated by Occam's Razor. This is not strictly true. Occam's Razor is used to separate a complex theory from a simple theory, the two theories being different. In the case of Poincare's and Lorentz's aether theories both contain the Lorentz Transformation which is already sufficient to explain the Michelson and Morley Experiment, length contraction, time dilation etc. The aether theorists simply fail to notice that this is a possibility because they reject spacetime as a concept for reasons of philosophy or prejudice. In Poincaré's case he rejected spacetime because of philosophical objections to the idea of spatial or temporal extension.

It is curious that Einstein actually returned to thinking based on an aether for similar philosophical reasons to those that haunted Poincaré (See Granek 2001). The geometrical form of Special Relativity as formalised by Minkowski does not forbid action at a distance and this was considered to be dubious philosophically. This led Einstein, in 1920, to reintroduce some of Poincaré's ideas into the theory of General Relativity. Whether an aether of the type proposed by Einstein is truly required for physical theory is still an active question in physics. However, such an aether leaves the spacetime of Special Relativity almost intact and is a complex

merger of the material and geometrical that would be unrecognised by 19th century theorists.

- Einstein, A. (1905). Zur Elektrodynamik bewegter Körper, in Annalen der Physik. 17:891-921. <http://www.fourmilab.ch/etexts/einstein/specrel/www/>
- Granek, G (2001). Einstein's ether: why did Einstein come back to the ether? Apeiron, Vol 8, 3. <http://citeseer.ist.psu.edu/cache/papers/cs/32948/http:zSzzSzredshift.vif.comzSzJournalFileszSzV08NO3PDFzSzV08N3GRF.PDF/granek01einsteins.pdf>
- S. Walter. The non-Euclidean style of Minkowskian relativity. Published in J. Gray (ed.), The Symbolic Universe, Oxford University Press, 1999, 91–127. <http://www.univ-nancy2.fr/DepPhilo/walter/papers/nes.pdf>

## Intended Audience

This book presents special relativity (SR) from first principles and logically arrives at the conclusions. There will be simple diagrams and some thought experiments. Problems at the end of each section challenge the reader to apply what he or she has learned. Although the final form of the theory came to use Minkowski spaces and metric tensors, it is possible to discuss SR using nothing more than high school algebra. That is the method used here in the first half of the book which is intended for senior high school science students and junior undergraduates. That being said, the subject is open to a wide range of readers. All that is really required is a genuine interest.

For a more mathematically sophisticated treatment of the subject, please refer to Special Relativity. Part II: Advanced Text.

## What's so special?

The special theory was suggested in 1905 in Einstein's article "On the Electrodynamics of Moving Bodies", and is so called because they only apply in a special case: frames of reference that are not accelerating, or **inertial frames**. This is the same restriction that applies to Newton's Laws of Motion. We also don't consider the effect of gravitational fields in special relativity.

In search of a more complete theory, Einstein developed the general theory of relativity published in 1915. General relativity (GR), a more mathematically demanding subject, describes all frames. This includes accelerating frames and gravitational fields.

The conceptual difference between the two is the model of spacetime used. Special relativity makes use of a Euclidean-like (flat) spacetime. GR lives in a spacetime that is generally not flat but curved, and it is this



curvature which represents gravity. The domain of applicability for SR is not so limited, however. Spacetime can often be approximated as flat, and there are techniques to deal with accelerating special relativistic objects.

## Common Pitfalls in Relativity

Here is a collection of common misunderstandings and misconceptions about SR. If you are unfamiliar with SR then you can safely skip this section and come back to it later. If you are an instructor, perhaps this can help you divert some problems before they start by bringing up these points during your presentation when appropriate.

Beginners often believe that special relativity is only about objects that are moving at high velocities. This is a mistake. Special relativity applies at all velocities but at low velocity the predictions of special relativity are almost identical to those of the Newtonian empirical formulae. As an object increases its velocity the predictions of relativity gradually diverge from Newtonian Mechanics.

There is sometimes a problem differentiating between the two different concepts "relativity of simultaneity" and "signal latency/delay." When simultaneous events in one frame are viewed as not simultaneous in another it is either because:

1. They *truly aren't* simultaneous in the second frame due to relativistic effects, or,
2. They just appear that way due to delay of light, or both. They can occur together but the two effects are not the same thing. One can always factor out the light delay by calculating when the signal was transmitted using the speed of light and the distance to the object. Relativity isn't based solely on the finite speed of light, crazy stuff is really happening.

## A Word about Wiki

This is a Wikibook. That means it has great potential for improvement and enhancement. The improvement can be in the form of refined language, clear math, simple diagrams, and better practice problems and answers. The enhancement can be in the form of artwork, historical context of SR, anything. Feel free to improve and enhance Special Relativity and other Wikibooks as you see necessary. And yes, it's necessary!

# The principle of relativity

Principles of relativity address the problem of how events that occur in one place are observed from another place. This problem has been a difficult theoretical challenge since the earliest times.

[Aristotle](#) argued in his "Physics" that things must either be moved or be at rest. According to Aristotle, on the basis of complex and interesting arguments about the possibility of a 'void', things cannot remain in a state of motion without something moving them. As a result Aristotle proposed that objects would stop entirely in empty space.

[Galileo](#) challenged this idea of movement being due to a continuous action of something that causes the movement. In his "Dialogue Concerning the Two Chief World Systems" he considers observations of motion made by people inside a ship who could not see the outside:

"have the ship proceed with any speed you like, so long as the motion is uniform and not fluctuating this way and that. You will discover not the least change in all the effects named, nor could you tell from any of them whether the ship was moving or standing still."

According to Galileo, if the ship moves smoothly someone inside it would be unable to determine whether they are moving. This concept leads to **Galilean Relativity** in which it is held that things continue in a state of motion unless acted upon.

Galilean Relativity contains two important principles: firstly it is impossible to determine who is actually at rest and secondly things continue in uniform motion unless acted upon. The second principle is known as Galileo's Law of Inertia or Newton's First Law of Motion.

Reference:

- Galileo Galilei (1632). Dialogues Concerning the Two Chief World Systems.
- Aristotle (350BC). Physics. <http://classics.mit.edu/Aristotle/physics.html>

## Frames of reference, events and transformations

Physical observers are considered to be surrounded by a **reference frame** which is a set of coordinate axes in terms of which position or movement may be specified or with reference to which physical laws may be mathematically stated.

An **inertial reference frame** is a collection of objects that have no net motion relative to each other. It is a coordinate system defined by the non-accelerated motion of objects with a common direction and speed.

An **event** is something that happens independently of the reference frame that might be used to describe it. Turning on a light or the collision of two objects would constitute an event.

Suppose there is a small event, such as a light being turned on, that is at coordinates  $x,y,z,t$  in one reference frame. What coordinates would another observer, in another reference frame moving relative to the first at velocity  $v$  along the  $x$  axis assign to the event? This problem is illustrated below:

### Transformation of Coordinates

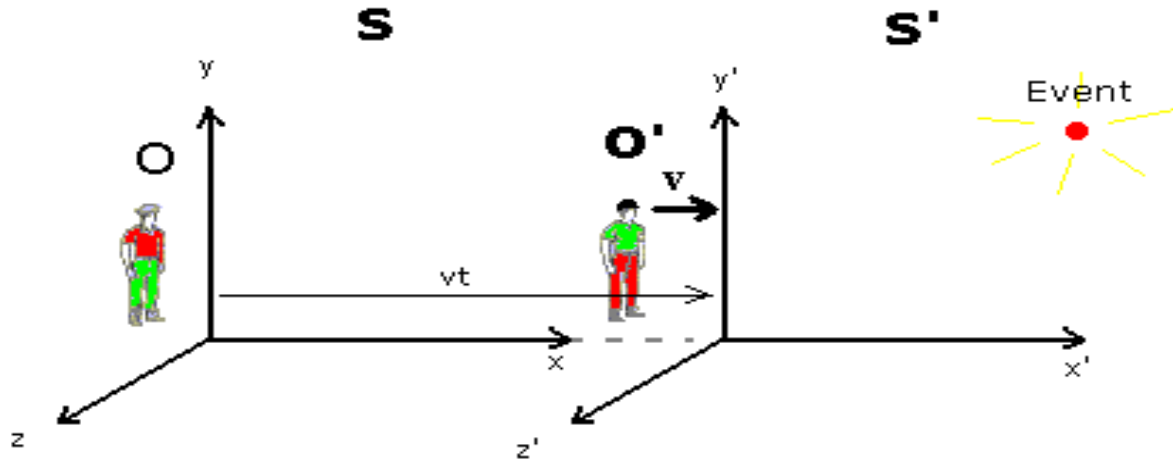

The observers are moving at a relative velocity of  $v$  and each observer has their own set of coordinates  $(x,y,z,t)$  and  $(x',y',z',t')$ . What coordinates do they assign to the event?

What we are seeking is the relationship between the second observer's coordinates  $x',y',z',t'$  and the first observer's coordinates  $x,y,z,t$ . According to Galilean Relativity:

$$x' = x - vt$$

$$y' = y$$

$$z' = z$$

$$t' = t$$

This set of equations is known as a **Galilean coordinate transformation** or **Galilean transformation**.

These equations show how the position of an event in one reference frame is related to the position of an event in another reference frame. But what happens if the event is something that is moving? How do velocities transform from one frame to another?

The calculation of velocities depends on Newton's formula:  $v = dx / dt$ . The use of Newtonian physics to calculate velocities and other physical variables has led to Galilean Relativity being called **Newtonian Relativity** in the case where conclusions are drawn beyond simple changes in coordinates. The velocity transformations for the velocities in the three directions in space are, according to Galilean relativity:

$$u'_x = u_x - v$$

$$u'_y = u_y$$

$$u'_z = u_z$$

This result is known as the **classical velocity addition theorem** and summarises the transformation of velocities between two Galilean frames of reference. It means that the velocities of projectiles must be determined relative to the velocity of the source and destination of the projectile. For example, if a sailor throws a stone at 10 km/hr from Galileo's ship which is moving towards shore at 5 km/hr then the stone will be moving at 15 km/hr when it hits the shore.

In Newtonian Relativity the geometry of space is assumed to be Euclidean and the measurement of time is assumed to be the same for all observers.

The derivation of the classical velocity addition theorem is as follows:

If the Galilean transformations are differentiated with respect to time:

$$x' = x - vt$$

So:

$$dx' / dt = dx / dt - v$$

But in Galilean relativity  $t' = t$  and so  $dx' / dt' = dx' / dt$  therefore:

$$dx' / dt' = dx / dt - v$$

$$dy' / dt' = dy / dt$$

$$dz' / dt' = dz / dt$$

If we write  $u'_x = dx' / dt'$  etc. then:

$$u'_x = u_x - v$$

$$u'_y = u_y$$

$$u'_z = u_z$$

## Special relativity

In the nineteenth century James Clerk Maxwell discovered the equations that describe the propagation of electromagnetic waves such as light. For example, one of his equations determines the velocity of light based on the permittivity and permeability of the medium through which it travels. If one assumes that both the Maxwell equations are valid, and that the Galilean transformation is the appropriate transformation, then it

should be possible to measure velocity absolutely and there should be a **preferred reference frame**. The preferred reference frame could be considered the true zero point to which all velocity measurements could be referred.

Special relativity restored a principle of relativity in physics by maintaining that although Maxwell's equations are correct Galilean relativity is wrong: there is no preferred reference frame. Special relativity brought back the interpretation that in all inertial reference frames the same physics is going on and there is no phenomenon that would allow an observer to pinpoint a zero point of velocity. Einstein extended the principle of relativity by proposing that the laws of physics are the same regardless of inertial frame of reference. According to Einstein, whether you are in the hold of Galileo's ship or in the cargo bay of a space ship going at a large fraction of the speed of light the laws of physics will be the same.

## **The postulates of special relativity**

### 1. First postulate: the principle of relativity

Observation of physical phenomena by more than one inertial observer must result in agreement between the observers as to the nature of reality. Or, the nature of the universe must not change for an observer if their inertial state changes. Every physical theory should look the same mathematically to every inertial observer. Formally: **the laws of physics are the same regardless of inertial frame of reference.**

### 2. Second postulate: invariance of the speed of light

The speed of light in vacuum, commonly denoted  $c$ , is the same to all inertial observers, is the same in all directions, and does not depend on the velocity of the object emitting the light. Formally: **the speed of light in free space is a constant in all inertial frames of reference.**

Using these postulates Einstein was able to calculate how the observation of events depends upon the relative velocity of observers. He was then able to construct a theory of physics that led to predictions such as the equivalence of mass and energy and early quantum theory.

# The spacetime interpretation of special relativity

Although the special theory of relativity was first proposed by Einstein in 1905, the modern approach to the theory depends upon the concept of a four-dimensional universe, that was first proposed by Hermann Minkowski in 1908, and further developed as a result of the contributions of Emmy Noether. This approach uses the concept of invariance to explore the types of coordinate systems that are required to provide a full physical description of the location and extent of things.

The modern theory of special relativity begins with the concept of "length". In everyday experience, it seems that the length of objects remains the same no matter how they are rotated or moved from place to place. We think that the simple length of a thing is "invariant". However, as is shown in the illustrations below, what we are actually suggesting is that length seems to be invariant in a three-dimensional coordinate system.

**Figure 1: Invariance of length on a Euclidean plane.**

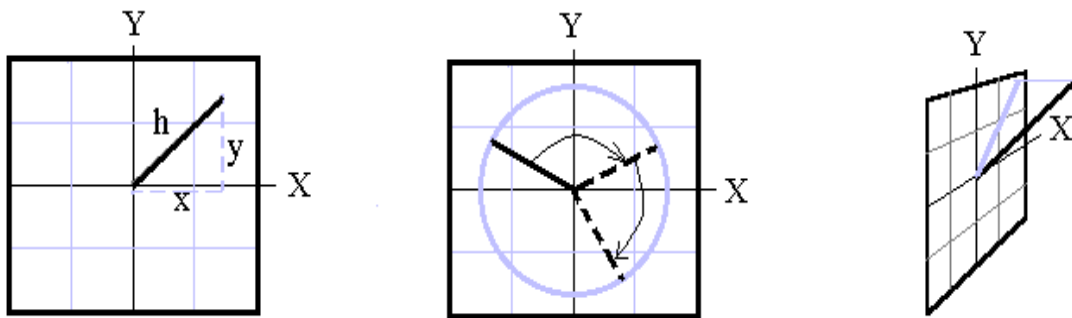

The length of a thing in a two dimensional coordinate system is given by Pythagoras' theorem.  $h^2 = x^2 + y^2$

In the 2D plane length is invariant during rotations on the plane. The length is also invariant if the thing is just moved from place to place (translational invariance).

If a thing rotates out of the plane the length it projects on the plane is no longer equal to the real length of the thing.

The length of a thing in a two-dimensional coordinate system is given by Pythagoras' theorem:

$$h^2 = x^2 + y^2$$

This two-dimensional length is not invariant if the thing is tilted out of the two-dimensional plane. In everyday life, a three-dimensional coordinate system seems to describe the length fully. The length is given by the three-dimensional version of Pythagoras' theorem:

$$h^2 = x^2 + y^2 + z^2$$

The derivation of this formula is shown in the illustration below.

**Figure 2: Invariance in a 3D Euclidean space.**

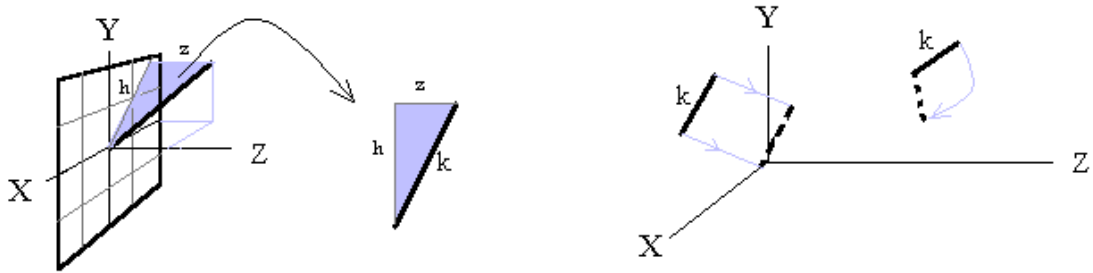

The length of an object in a three dimensional coordinate system is given by the 3D version of Pythagoras' theorem:

$$k^2 = h^2 + z^2 \text{ but } h^2 = x^2 + y^2$$

$$k^2 = x^2 + y^2 + z^2$$

In a three dimensional coordinate system it seems that the real length of a thing stays the same (is INVARIANT) during translations and rotations. It appears to be always given by:

$$k^2 = x^2 + y^2 + z^2$$

It seems that, provided all the directions in which a thing can be tilted or arranged are represented within a coordinate system, then the coordinate system can fully represent the length of a thing. However, it is clear that things may also be changed over a period of time. We must think of time as another direction in which things can be arranged. This is shown in the following diagram:

**Figure 3: The invariant space-time interval.**

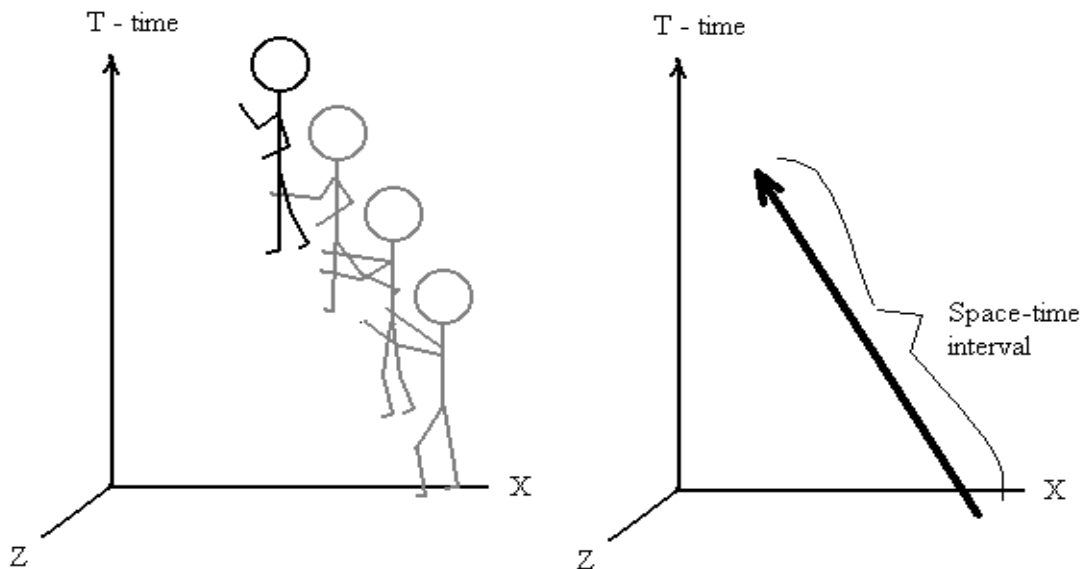

Motions can be represented as lengths spanning both space and time in a coordinate system. These lengths are called SPACE-TIME INTERVALS. Time can be considered to be yet another direction for arranging things. This suggests that the universe could be four dimensional. If the universe is truly four dimensional then space-time intervals would be invariant when things move .

The path taken by a thing in both space and time is known as the space-time interval.

Hermann Minkowski realised in 1908 that if things could be rearranged in time, then the universe might be four-dimensional. He boldly suggested that Einstein's recently-discovered theory of Special Relativity was a consequence of this four-dimensional universe. He proposed that the space-time interval might be related to space and time by Pythagoras' theorem in four dimensions:

$$s^2 = x^2 + y^2 + z^2 + (ict)^2$$

Where  $i$  is the imaginary unit (sometimes imprecisely called  $\sqrt{-1}$ ),  $c$  is a constant, and  $t$  is the time interval spanned by the space-time interval,  $s$ . The symbols  $x$ ,  $y$  and  $z$  represent displacements in space along the corresponding axes. In this equation, the 'second' becomes just another unit of length. In the same way as centimetres and inches are both units of length related by centimetres = 'conversion constant' times inches, metres and seconds are related by metres = 'conversion constant' times seconds. The conversion constant,  $c$  has a value of about 300,000,000 meters per second. Now  $i^2$  is equal to minus one, so the space-time interval is given by:

$$s^2 = x^2 + y^2 + z^2 - (ct)^2$$

Minkowski's use of the imaginary unit has been superseded by the use of advanced geometry, that uses a tool known as the "metric tensor", but his original equation survives, and the space-time interval is still given by:

$$s^2 = x^2 + y^2 + z^2 - (ct)^2$$

Space-time intervals are difficult to imagine; they extend between one place and time and another place and time, so the velocity of the thing that travels along the interval is already determined for a given observer.

If the universe is four-dimensional, then the space-time interval will be invariant, rather than spatial length. Whoever measures a particular space-time interval will get the same value, no matter how fast they are travelling. The invariance of the space-time interval has some dramatic consequences.

The first consequence is the prediction that if a thing is travelling at a velocity of  $c$  metres per second, then all observers, no matter how fast they are travelling, will measure the same velocity for the thing. The velocity  $c$  will be a universal constant. This is explained below.

When an object is travelling at  $c$ , the space time interval is **zero**, this is shown below:

$$\text{The space-time interval is } s^2 = x^2 + y^2 + z^2 - (ct)^2$$

The distance travelled by an object moving at velocity  $v$  in the  $x$  direction for  $t$  seconds is:

$$x = vt$$



If there is no motion in the  $y$  or  $z$  directions the space-time interval is  $s^2 = x^2 + 0 + 0 - (ct)^2$

So:  $s^2 = (vt)^2 - (ct)^2$

But when the velocity  $v$  equals  $c$ :

$s^2 = (ct)^2 - (ct)^2$

And hence the space time interval  $s^2 = (ct)^2 - (ct)^2 = 0$

A space-time interval of zero only occurs when the velocity is  $c$ . When observers observe something with a space-time interval of zero, they all observe it to have a velocity of  $c$ , no matter how fast they are moving themselves.

The universal constant,  $c$ , is known for historical reasons as the "speed of light". In the first decade or two after the formulation of Minkowski's approach many physicists, although supporting Special Relativity, expected that light might not travel at exactly  $c$ , but might travel at very nearly  $c$ . There are now few physicists who believe that light does not propagate at  $c$ .

The second consequence of the invariance of the space-time interval is that clocks will appear to go slower on objects that are moving relative to you. Suppose there are two people, Bill and John, on separate planets that are moving away from each other. John draws a graph of Bill's motion through space and time. This is shown in the illustration below:

**Figure 4: John and Bill - observers moving away from each other.**

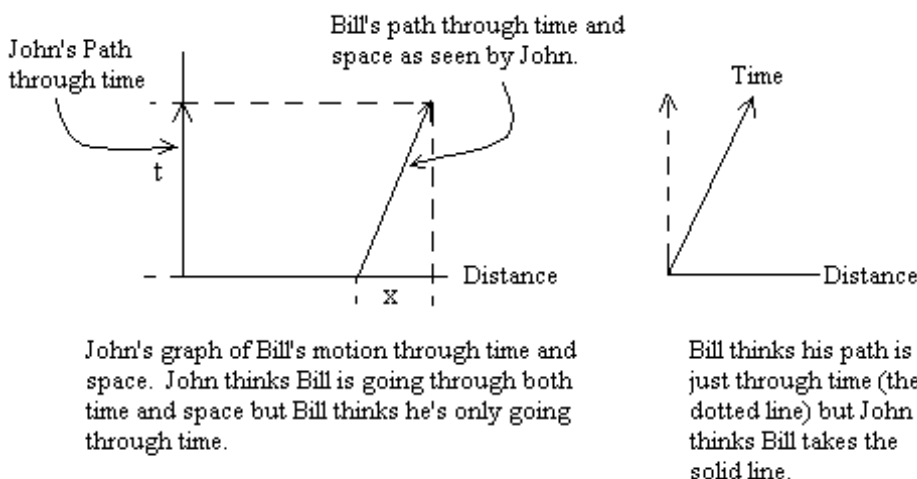

Being on planets, both Bill and John think they are stationary, and just moving through time. John spots that Bill is moving through what John calls space, as well as time, when Bill thinks he is moving through time

alone. Bill would also draw the same conclusion about John's motion. To John, it is as if Bill's time axis is leaning over in the direction of travel and to Bill, it is as if John's time axis leans over.

John calculates the length of Bill's space-time interval as:

$$s^2 = (vt)^2 - (ct)^2$$

whereas Bill doesn't think he has travelled in space, so writes:

$$s^2 = (0)^2 - (cT)^2$$

The space-time interval,  $s^2$ , is invariant. It has the same value for all observers, no matter who measures it or how they are moving in a straight line. Bill's  $s^2$  equals John's  $s^2$  so:

$$(0)^2 - (cT)^2 = (vt)^2 - (ct)^2$$

and

$$-(cT)^2 = (vt)^2 - (ct)^2$$

hence

$$t = T / \sqrt{1 - v^2/c^2}$$

So, if John sees Bill measure a time interval of 1 second ( $T = 1$ ) between two ticks of a clock that is at rest in Bill's frame, John will find that his own clock measures between these same ticks an interval  $t$ , called **coordinate time**, which is greater than one second. It is said that clocks in motion slow down, relative to those on observers at rest. This is known as "relativistic time dilation of a moving clock". The time that is measured in the rest frame of the clock (in Bill's frame) is called the **proper time** of the clock.

John will also observe measuring rods at rest on Bill's planet to be shorter than his own measuring rods, in the direction of motion. This is a prediction known as "relativistic length contraction of a moving rod". If the length of a rod at rest on Bill's planet is  $X$ , then we call this quantity the proper length of the rod. The length  $x$  of that same rod as measured on John's planet, is called **coordinate length**, and given by

$$x = X \sqrt{1 - v^2/c^2}$$

See section on the Lorentz transformation below.

The last consequence is that clocks will appear to be out of phase with each other along the length of a

moving object. This means that if one observer sets up a line of clocks that are all synchronised so they all read the same time, then another observer who is moving along the line at high speed will see the clocks all reading different times. In other words observers who are moving relative to each other see different events as **simultaneous**. This effect is known as **Relativistic Phase** or the **Relativity of Simultaneity**. Relativistic phase is often overlooked by students of Special Relativity, but if it is understood then phenomena such as the twin paradox are easier to understand.

The way that clocks go out of phase along the line of travel can be calculated from the concepts of the invariance of the space-time interval and length contraction.

### How clocks become out of phase along the line of travel

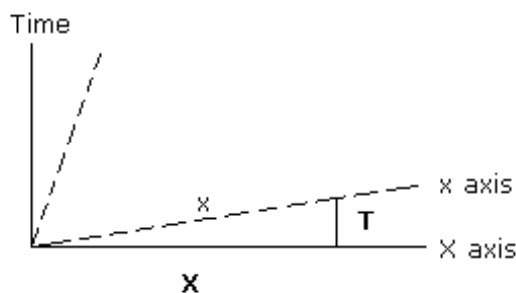

$$T = xv/c^2$$

The relationship for comparing lengths in the direction of travel is given by:

$$x = X\sqrt{1 - v^2/c^2}$$

So distances between two points according to Bill are simple lengths in space (X) whereas John sees Bill's measurement of distance as a combination of a distance (x) and a time interval:

$$x^2 = X^2 - (cT)^2$$

But from :  $x = X\sqrt{1 - v^2/c^2}$

$$x^2 = X^2 - (v^2/c^2)X^2$$

$$\text{So: } (cT)^2 = (v^2/c^2)X^2$$

$$\text{And } cT = (v/c)X$$

$$\text{So: } T = (v/c^2)X$$

Clocks that are synchronised for one observer go out of phase along the line of travel for another observer moving at  $v$  metres per second by  $(v / c^2)$  seconds for every metre. This is one of the most important results of Special Relativity and is often neglected by students.

The net effect of the four-dimensional universe is that observers who are in motion relative to you seem to have time coordinates that lean over in the direction of motion, and consider things to be simultaneous, that are not simultaneous for you. Spatial lengths in the direction of travel are shortened, because they tip upwards and downwards, relative to the time axis in the direction of travel, akin to a rotation out of three-dimensional space.

**Figure 5: How Bill's coordinates appear to John at the instant Bill passes him.**

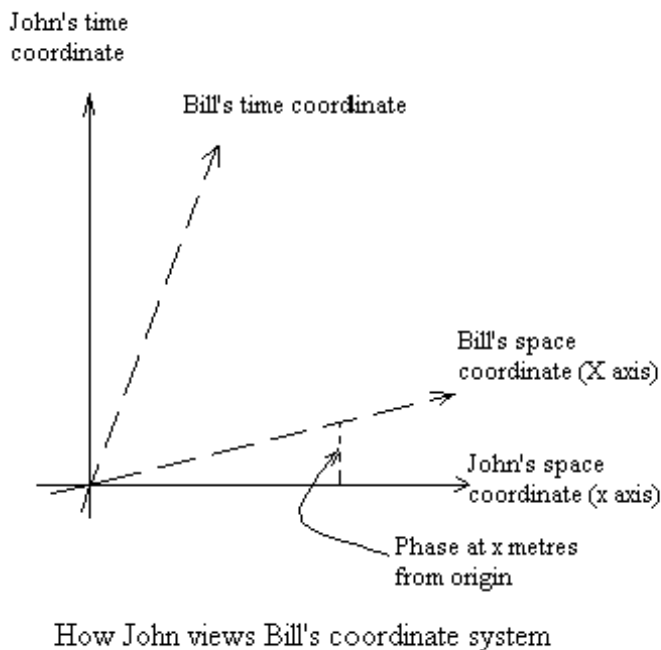

Great care is needed when interpreting space-time diagrams. Diagrams present data in two dimensions, and cannot show faithfully how, for instance, a zero length space-time interval appears.

**Figure 6: Space-time diagrams are often misleading**

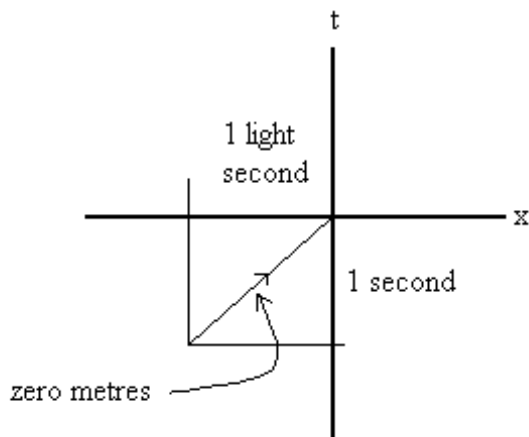

The path of a light ray is a space-time interval of zero but appears as a long line in the diagram.

## Spacetime

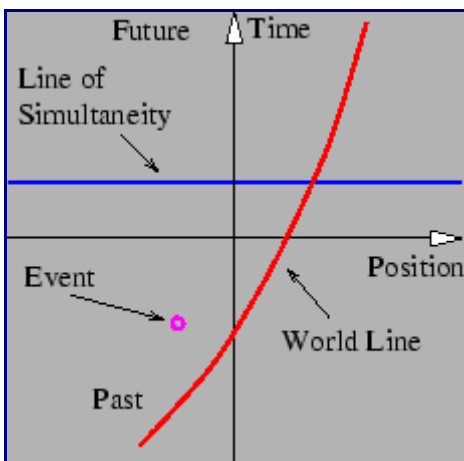

Spacetime diagram showing an *event*, a *world line*, and a *line of simultaneity*.

In order to gain an understanding of both Galilean and Special Relativity it is important to begin thinking of space and time as being different dimensions of a four-dimensional vector space called spacetime. Actually, since we can't visualize four dimensions very well, it is easiest to start with only one space dimension and the time dimension. The figure shows a graph with time plotted on the vertical axis and the one space dimension plotted on the horizontal axis. An *event* is something that occurs at a particular time and a particular point in space. ("Julius X. wrecks his car in Lemitar, NM on 21 June at 6:17 PM.") A *world line* is a plot of the position of some object as a function of time (more properly, the time of the object as a function of position) on a spacetime diagram. Thus, a world line is really a line in spacetime, while an event is a point in spacetime. A horizontal line parallel to the position axis (x-axis) is a *line of simultaneity*; in Galilean Relativity all events on this line occur simultaneously for all observers. It will be seen that the line of simultaneity differs between Galilean and Special Relativity; in Special Relativity the line of simultaneity

depends on the state of motion of the observer.

In a spacetime diagram the slope of a world line has a special meaning. Notice that a vertical world line means that the object it represents does not move -- the velocity is zero. If the object moves to the right, then the world line tilts to the right, and the faster it moves, the more the world line tilts. Quantitatively, we say that

$$velocity = \frac{1}{\text{slope of world line}}. \quad (5.1)$$

Notice that this works for negative slopes and velocities as well as positive ones. If the object changes its velocity with time, then the world line is curved, and the instantaneous velocity at any time is the inverse of the slope of the tangent to the world line at that time.

The hardest thing to realize about spacetime diagrams is that they represent the past, present, and future all in one diagram. Thus, spacetime diagrams don't change with time -- the evolution of physical systems is represented by looking at successive horizontal slices in the diagram at successive times. Spacetime diagrams represent the evolution of events, but they don't evolve themselves.

## The lightcone

Things that move at the speed of light in our four dimensional universe have surprising properties. If something travels at the speed of light along the x-axis and covers x meters from the origin in t seconds the space-time interval of its path is zero.

$$s^2 = x^2 - (ct)^2$$

but  $x = ct$  so:

$$s^2 = (ct)^2 - (ct)^2 = 0$$

Extending this result to the general case, if something travels at the speed of light in any direction into or out from the origin it has a space-time interval of 0:

$$0 = x^2 + y^2 + z^2 - (ct)^2$$

This equation is known as the Minkowski Light Cone Equation. If light were travelling towards the origin then the Light Cone Equation would describe the position and time of emission of all those photons that could be at the origin at a particular instant. If light were travelling away from the origin the equation would describe the position of the photons emitted at a particular instant at any future time 't'.

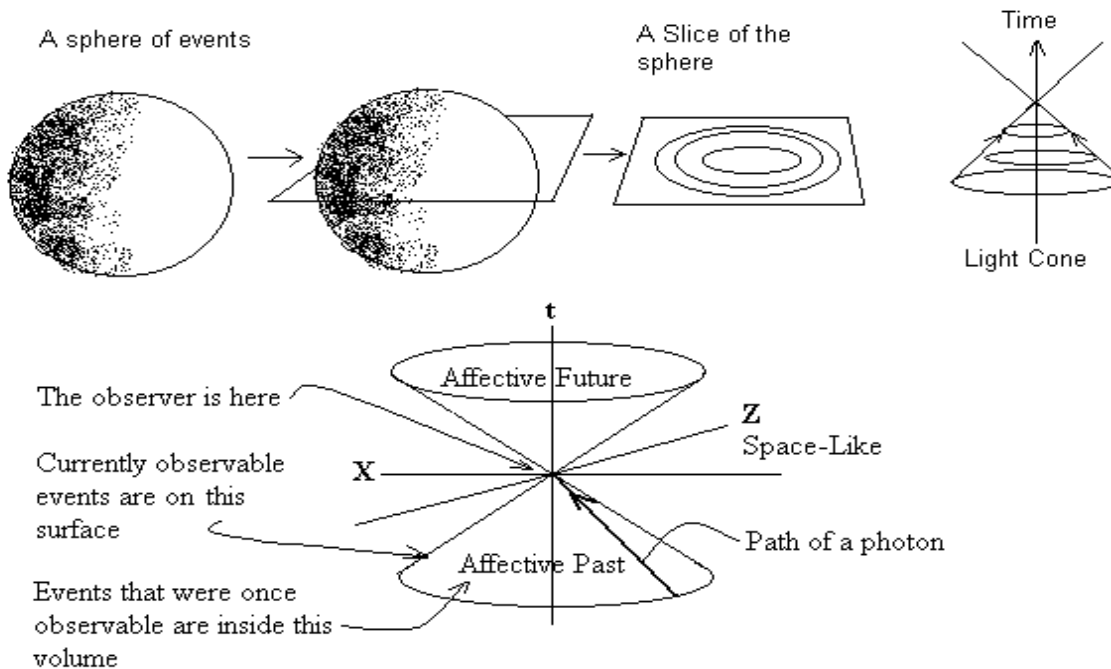

A Slice of a Sphere of Events Represented by a Light Cone (Solution of  $0 = x^2 + z^2 - (ct)^2$ )

At the superficial level the light cone is easy to interpret. It's backward surface represents the path of light rays that strike a point observer at an instant and it's forward surface represents the possible paths of rays emitted from the point observer at an instant (assuming the conditions appropriate to a special relativistic treatment prevail). Things that travel along the surface of the light cone are said to be **light-like** and the path taken by such things is known as a **null geodesic**.

Events that lie outside the cones are said to be **space-like** or, better still **space separated** because their space time interval from the observer has the same sign as space (positive according to the convention used here). Events that lie within the cones are said to be **time-like** or **time separated** because their space-time interval has the same sign as time.

However, there is more to the light cone than the propagation of light. If the added assumption is made that the speed of light is the maximum possible velocity then events that are space separated cannot affect the observer directly. Events within the backward cone can have affected the observer so the backward cone is known as the "affective past" and the observer can affect events in the forward cone hence the forward cone is known as the "affective future".

The assumption that the speed of light is the maximum velocity for all communications is neither inherent in nor required by four dimensional geometry although the speed of light is indeed the maximum velocity for objects if the principle of **causality** is to be preserved by physical theories (ie: that causes precede effects).

# The Lorentz transformation equations

The discussion so far has involved the comparison of interval measurements (time intervals and space intervals) between two observers. The observers might also want to compare more general sorts of measurement such as the time and position of a single event that is recorded by both of them. The equations that describe how each observer describes the other's recordings in this circumstance are known as the Lorentz Transformation Equations. (Note that the symbols below signify coordinates.)

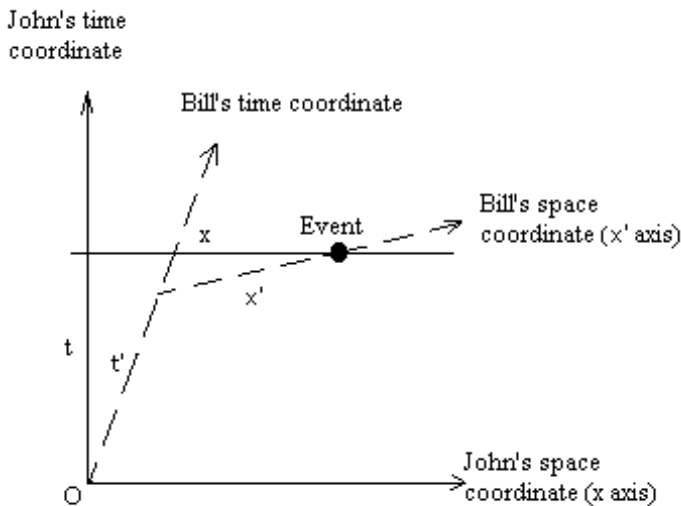

The Lorentz Transformation: How observers with two different coordinate systems view the same event. In this case John and Bill are in space vehicles travelling past each other at 'O' where they synchronise clocks.

The objective is to calculate what the other observer reports as the time and position of the event

The table below shows the Lorentz Transformation Equations.

$x' = \frac{x - vt}{\sqrt{(1 - v^2/c^2)}}$	$x = \frac{x' + vt'}{\sqrt{(1 - v^2/c^2)}}$
$y' = y$	$y = y'$
$z' = z$	$z = z'$
$t' = \frac{t - (v/c^2)x}{\sqrt{(1 - v^2/c^2)}}$	$t = \frac{t' + (v/c^2)x'}{\sqrt{(1 - v^2/c^2)}}$

See appendix 1 for the derivation of these equations.



Notice how the phase ( $v/c^2)x$ ) is important and how these formulae for absolute time and position of a joint event differ from the formulae for intervals.

## More about the relativity of simultaneity and the Andromeda paradox

If two observers who are moving relative to each other synchronise their clocks in their own frames of reference they discover that the clocks do not agree between the reference frames. This is illustrated below:

### The Relativity of Simultaneity and Phase

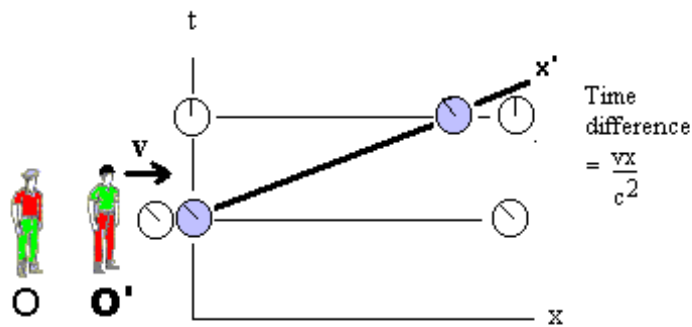

Phase describes how events that one observer measures to be simultaneous are not simultaneous for another observer.

The effect of the relativity of simultaneity, or "phase", is for each observer to consider that a different set of events is simultaneous. Phase means that observers who are moving relative to each other have different sets of things that are simultaneous, or in their "present moment".

**Figure 5: How Bill's coordinates appear to John at the instant Bill passes him.**

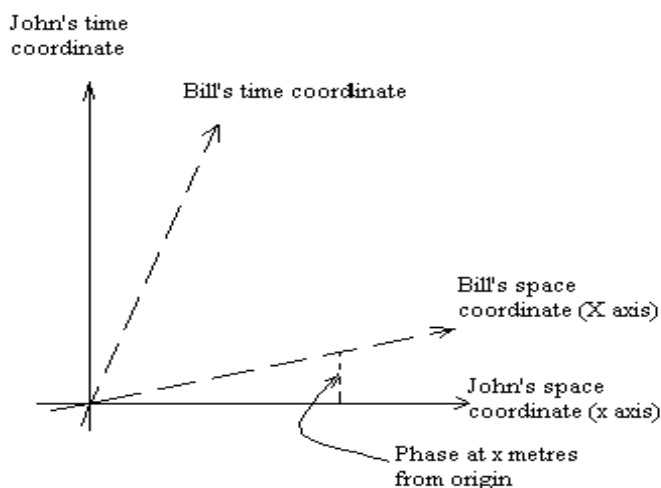

How John views Bill's coordinate system

The amount by which the clocks differ between two observers depends upon the distance of the

clock from the observer ( $t = xv / c^2$ ). Notice that if both observers are part of inertial frames of reference with clocks that are synchronised at every point in space then the phase difference can be obtained by simply reading the difference between the clocks at the distant point and clocks at the origin. This difference will have the same value for both observers.

Relativistic phase differences have the startling consequence that at distances as large as our separation from nearby galaxies an observer who is driving on the earth can have a radically different set of events in her "present moment" from another person who is standing on the earth. The classic example of this effect of phase is the "Andromeda Paradox", also known as the "Rietdijk-Putnam-Penrose" argument. Penrose described the argument:

"Two people pass each other on the street; and according to one of the two people, an Andromedan space fleet has already set off on its journey, while to the other, the decision as to whether or not the journey will actually take place has not yet been made. How can there still be some uncertainty as to the outcome of that decision? If to either person the decision has already been made, then surely there cannot be any uncertainty. The launching of the space fleet is an inevitability." (Penrose 1989).

The argument is illustrated below:

### The Andromeda Paradox

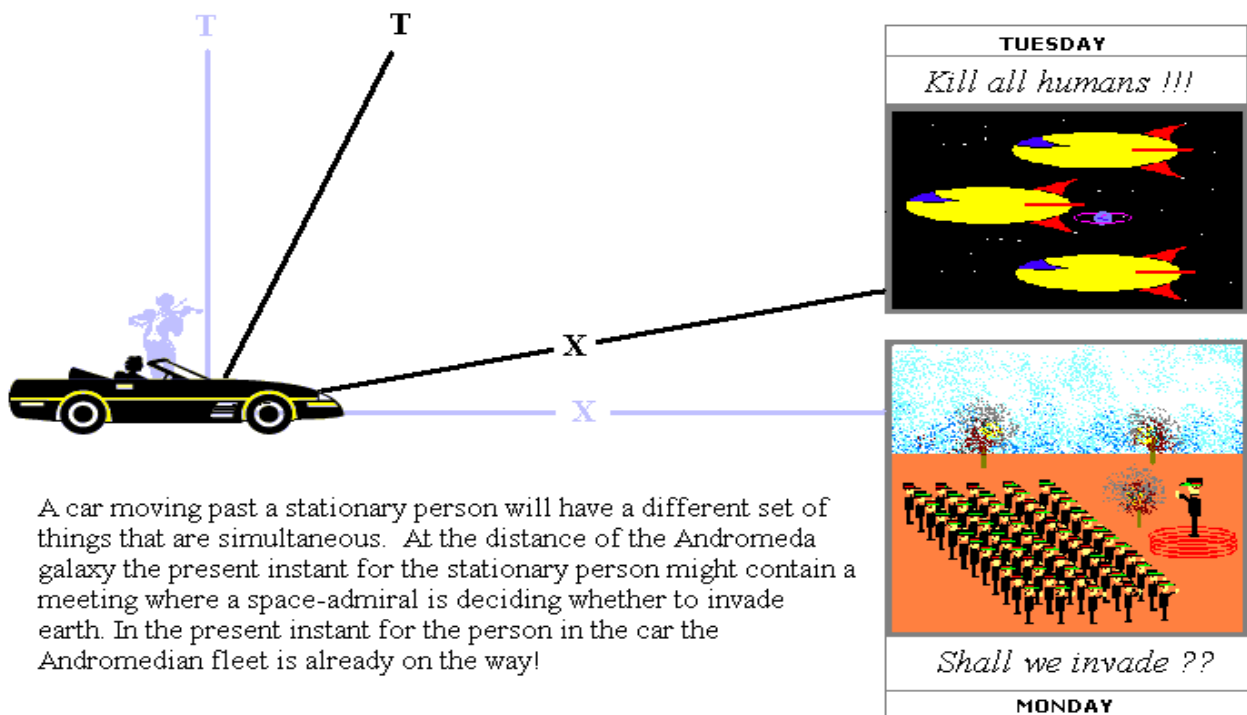

This "paradox" has generated considerable philosophical debate on the nature of time and free-will.

A result of the relativity of simultaneity is that if the car driver launches a space rocket towards the Andromeda galaxy it might have a several days head start compared with a space rocket launched from the ground. This is because the "present moment" for the moving car driver is progressively advanced with distance compared with the present moment on the ground. The present moment for the car driver is shown in the illustration below:

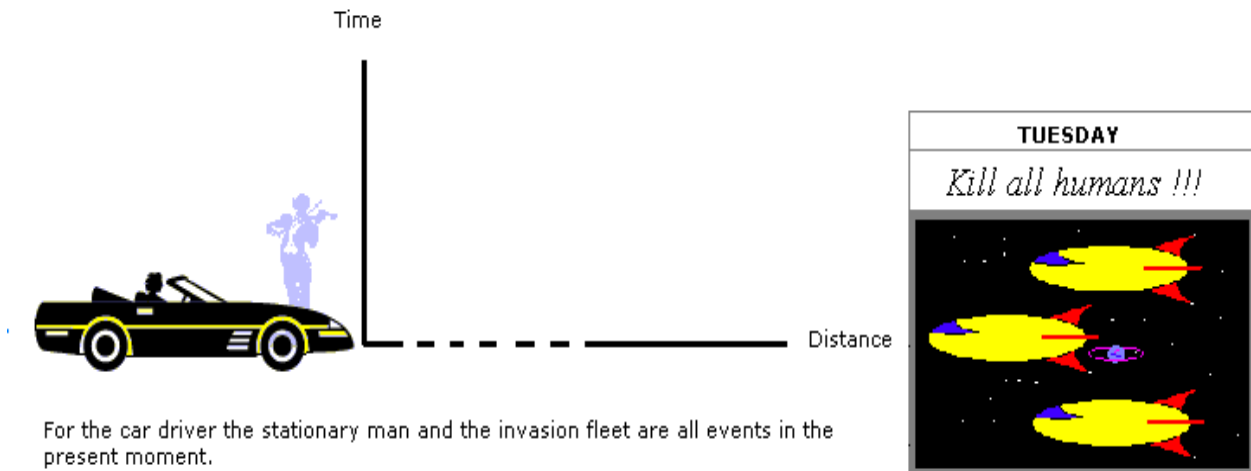

The result of the Andromeda paradox is that when someone is moving towards a distant point there are later events at that point than for someone who is not moving towards the distant point. There is a **time gap** between the events in the present moment of the two people.

## The nature of length contraction

According to special relativity items such as measuring rods consist of events distributed in space and time. This means that two observers moving relative to each other will usually be observing measuring rods that are composed of **different** sets of events. If the word "rod" means the three dimensional form of the object called a rod then these two observers in relative motion **observe different rods**. Each observer has a different rod in their present moment. The way that observers observe different sets of events is shown in the illustration below:

The relativity of simultaneity means that relatively moving observers observe different measuring rods.

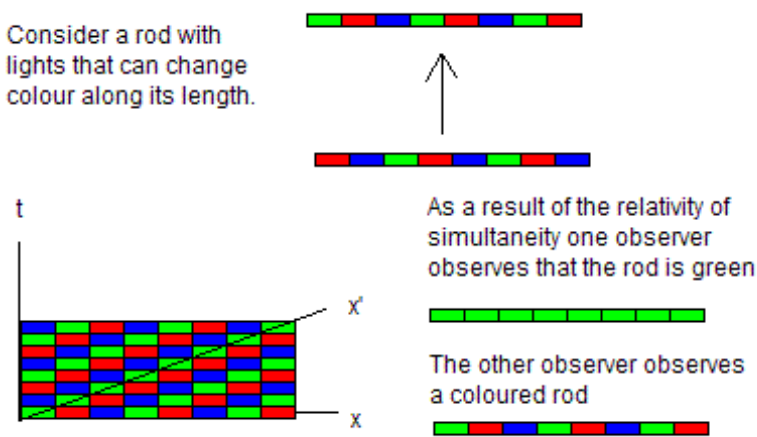

Each three dimensional section of the world is those events that are at an observer's present instant or present moment. The area of a Minkowski diagram that corresponds to all of the events that compose an object over a period of time is known as the **worldtube** of the object. It can be seen in the image below that length contraction is the result of observer's having different sections of an object's worldtube in their present instant.

### The Nature of Length Contraction

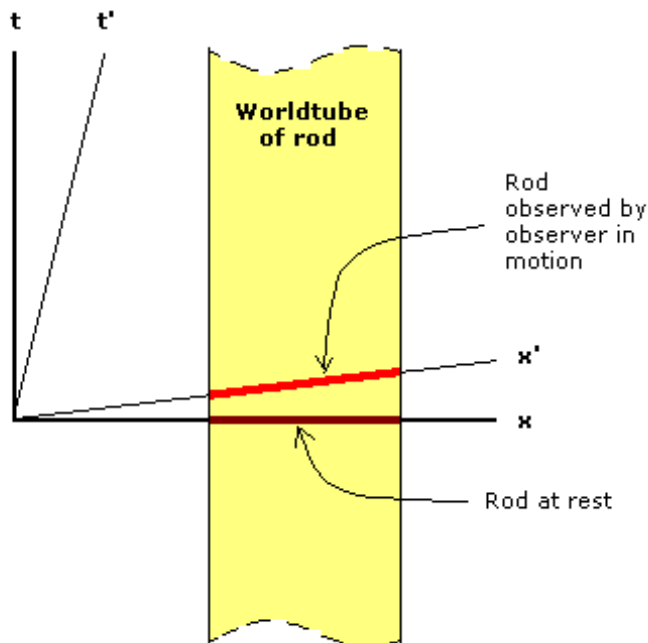

(It should be recalled that the longest lengths on space-time diagrams are often the shortest in reality).

It is sometimes said that length contraction occurs because objects rotate into the time axis. This is partly true but there is no actual rotation of a three dimensional rod, instead the observed three dimensional slice of a four dimensional rod is changed which makes it appear as if the rod has rotated into the time axis.

There can be no doubt that the three dimensional slice of the worldtube of a rod does indeed have different lengths for relatively moving observers so that the relativistic contraction of the rod is a real, physical phenomenon.

The issue of whether or not the events that compose the worldtube of the rod are always existent is a matter for philosophical speculation.

Further reading: [Vesselin Petkov. \(2005\) Is There an Alternative to the Block Universe View?](#)

### **Evidence for length contraction, the field of an infinite straight current**

Length contraction can be directly observed in the field of an infinitely straight current. This is shown in the illustration below.

## The Relationship between Electricity and Magnetism

Two results from classical electromagnetism for fields  $R$  meters away from a current carrying wire:

The magnetic field is given by the Biot-Savart law:  $B = \frac{\mu_0 \mathbf{I}}{2\pi r}$  and  $\mathbf{I} = \lambda \mathbf{v}$  so:  $B = \frac{\mu_0 \lambda v}{2\pi r}$

The electric field is given by:  $E = \frac{\lambda}{2\pi\epsilon_0 r}$

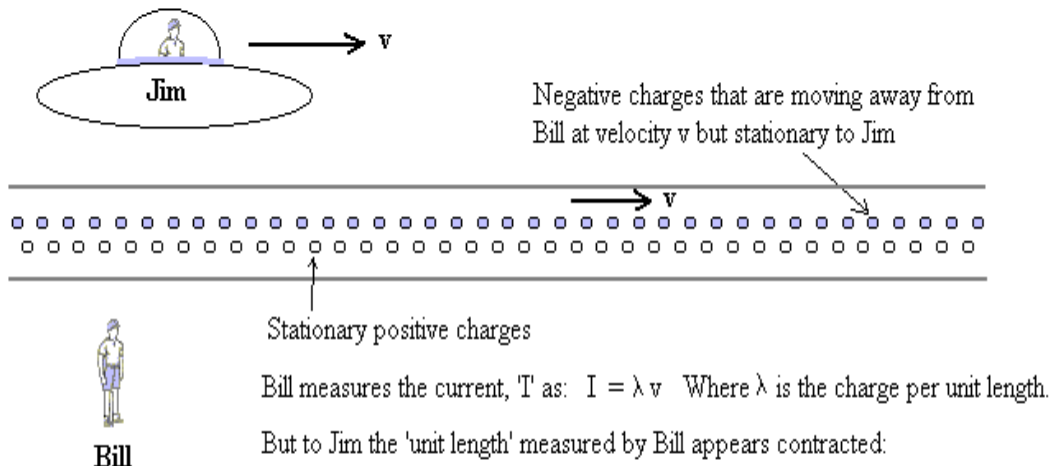

The excess positive charge density measured by Jim =  $\lambda(1/\sqrt{1 - v^2/c^2} - 1)$  Using the binomial approximation =  $\lambda v^2/2c^2$

The force on a charge,  $q$ , due to the magnetic field at Bill's position:  $F = Bqv = \frac{q\mu_0 \lambda v^2}{2\pi r}$

The force on a charge,  $q$ , due to the excess electric field at Jim's position is:  $F = Eq = \frac{q\lambda v^2}{2\pi\epsilon_0 r c^2}$

Again from classical electromagnetism:  $c^2 = 1/\epsilon_0\mu_0$

Substituting this into  $\frac{q\lambda v^2}{2\pi\epsilon_0 r c^2}$  the force due to the electric field found by Jim  $\frac{q\mu_0 \lambda v^2}{2\pi r}$  is equal to that due to the

magnetic field found by Bill.

It can be seen that once the idea of space-time is understood the unification of the two fields is straightforward. Jim is moving relative to the wire at the same speed as the negatively charged current carriers so Jim only experiences an electric field. Bill is stationary relative to the wire and observes the electrostatic attraction between Jim and the current carriers as a magnetic field. Bill observes that the charges in the wire are balanced whereas Jim observes an imbalance of charge.

It is important to notice that, in common with the explanation of length contraction given above, the events that constitute the stream of negative charges for Jim are not the same events as constitute the stream of negative charges for Bill. Bill and Jim's negative charges occupy different moments in time.

Incidentally, the drift velocity of electrons in a wire is about a millimetre per second but the electrons move at about a million metres a second between collisions (See link below).

Useful links:

<http://hyperphysics.phy-astr.gsu.edu/hbase/electric/ohmmic.html>

<http://hyperphysics.phy-astr.gsu.edu/hbase/relativ/releng.html>

## De Broglie waves

De Broglie noticed that the differing three dimensional sections of the universe would cause oscillations in the rest frame of an observer to appear as wave trains in the rest frame of observers who are moving.

### De Broglie Waves

A light tube is 'on' for a moment



Then goes off

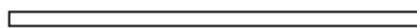

Then on again



The flashing light can be represented as a worldtube.

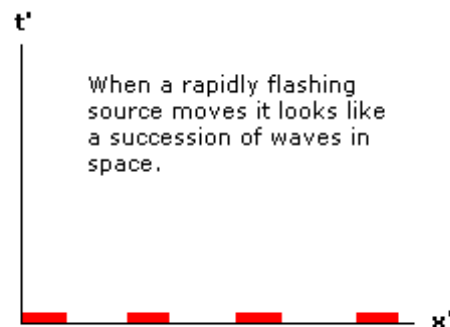
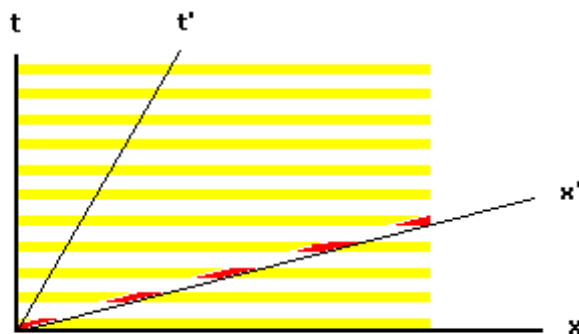

When a rapidly flashing source moves it looks like a succession of waves in space.

He combined this insight with Einstein's ideas on the quantisation of energy to create the foundations of quantum theory. De Broglie's insight is also a round-about proof of the description of length contraction given above - observers in relative motion have differing three dimensional slices of a four dimensional universe. The existence of matter waves is direct experimental evidence of the relativity of simultaneity.



## De Broglie waves

De Broglie waves result from the differing planes of simultaneity for an observer and a moving particle field.

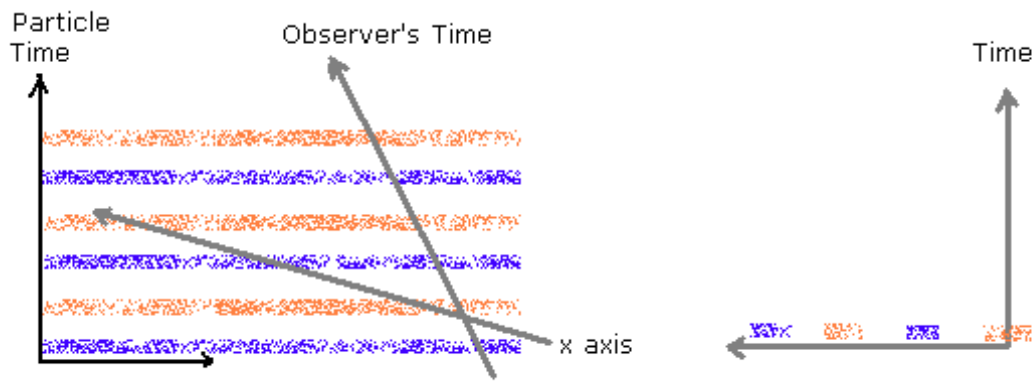

A De Broglie wave is an oscillation occurring simultaneously in the rest frame of the particle but not simultaneously in the frame of the observer.

The observer sees the oscillation as waves distributed in space

*Note: the plane of simultaneity of the observer is shown schematically above.*

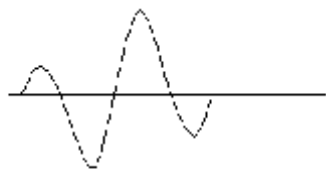

The effect is to produce a spatially distributed pulse

The Heisenberg uncertainty principle can be derived from the fourier transform of the pulse ie:

$$\psi(x) = \int_0^{\infty} g(k) \cos(kx) dk$$

$$\Delta k \approx 1 / (2 \Delta x)$$

$$\Delta k \Delta x \approx 1/2, \text{ but } k = 2\pi / \lambda = 2\pi p / h = p / \hbar,$$

$$\Delta p \Delta x \approx \hbar / 2$$

Further reading: de Broglie, L. (1925) On the theory of quanta. A translation of : RECHERCHES SUR LA THEORIE DES QUANTA (Ann. de Phys., 10e s'erie, t. III (Janvier-F'evrier 1925).by: A. F. Kracklauer. [http://www.ensmp.fr/aflb/LDB-oeuvres/De\\_Broglie\\_Kracklauer.pdf](http://www.ensmp.fr/aflb/LDB-oeuvres/De_Broglie_Kracklauer.pdf)

## More about time dilation

The term "time dilation" is applied to the way that observers who are moving relative to you record fewer clock ticks between events than you. In special relativity this is not due to properties of the clocks, it is due to shorter distances between events along an observer's path through spacetime. This can be seen most clearly by re-examining the Andromeda Paradox.

Suppose Bill passes Jim at high velocity on the way to Mars. Jim has previously synchronised the clocks on Mars with his Earth clocks but for Bill the Martian clocks read times well in advance of Jim's. This means that Bill has a head start because his present instant contains what Jim considers to be the Martian future. Jim observes that **Bill travels through both space and time**. However, Bill achieves this strange time travel by having what Jim considers to be the future of distant objects in his present moment. Bill is literally travelling into future parts of Jim's frame of reference.

In special relativity time dilation and length contraction are not material effects, they are physical effects due to travel within a four dimensional spacetime.

It is important for advanced students to be aware that special relativity and General Relativity differ about the nature of spacetime. General Relativity, in the form championed by Einstein, abolishes the idea of extended space and time and is what is known as a "relationalist" theory of physics. Special relativity, on the other hand, is a theory where extended spacetime is pre-eminent. The brilliant flowering of physical theory in the early twentieth century has tended to obscure this difference because, within a decade, special relativity had been subsumed within General Relativity. The interpretation of special relativity that is presented here should be learnt before advancing to more advanced interpretations.

## **The twin paradox**

The effects of the relativity of simultaneity such as are seen in the "Andromeda paradox" are, in part, the origin of the "twin paradox". In the twin paradox there are twins, Bill and Jim. Jim is on Earth. Bill flies past Jim in a spaceship, goes to a distant point, turns round and flies back again. It is found that Bill records fewer clock ticks over the whole journey than Jim records on earth. Why?

Suppose Jim has synchronised clocks on Earth and on the distant point. As Bill flies past Jim he synchronises his clock with Jim's clock. When he does this he observes the clocks on the distant point and immediately detects that they are not synchronised with his or Jim's clocks. To Bill it appears that Jim has synchronised his clocks incorrectly. There is a time difference, or "gap", between his clocks and those at the distant point even when he passes Jim. This difference is equal to the relativistic phase at the distant point. Bill flies to the distant point and discovers that the clock there is reading a later time than his own clock. He turns round to fly back to Earth and observes that the clocks on Earth seem to have jumped forward, yet another "time gap" appears. When Bill gets back to Earth the time gaps and time dilations mean that people on Earth have recorded more clock ticks than he did.

For ease of calculation suppose that Bill is moving at a truly astonishing velocity of  $0.8c$  in the direction of a distant point that is 10 light seconds away (about 3 million kilometres). The illustration below shows Jim and Bill's observations:

## The Time Gap Explanation of the Twin Paradox

### The outward journey

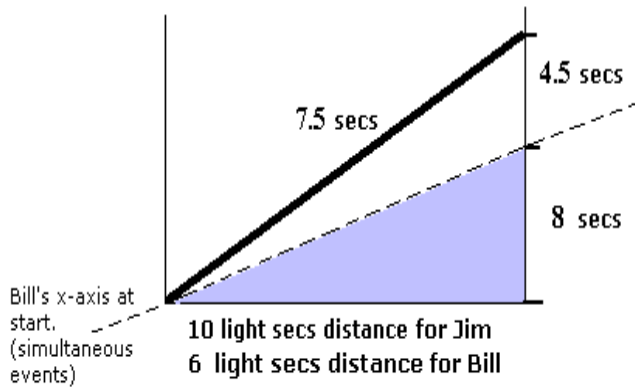

Bill travels 10 light secs at 0.8c so takes 12.5 secs to get to the destination according to Jim.

Bill observes the distance to be 6 light secs ie:  $10\sqrt{1-0.8^2}$

Bill takes 7.5 secs to make the journey according to his own clocks, ie:  $x/v = 6/0.8$

Bill observes ONLY 4.5 secs elapsed time on the clock at the destination.

The other 8 secs on the clock are due to the initial time gap. Even when Bill is next to Jim he sees that the destination is already 8 secs into Jim's future.

### The return journey

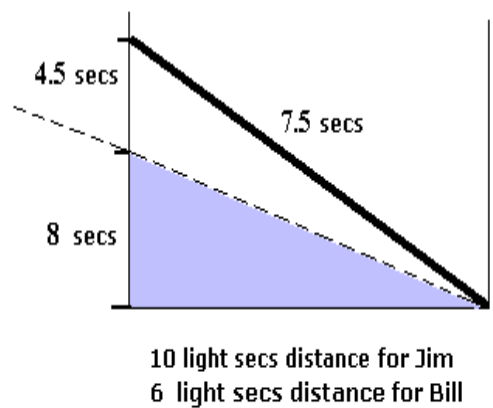

### The overall journey

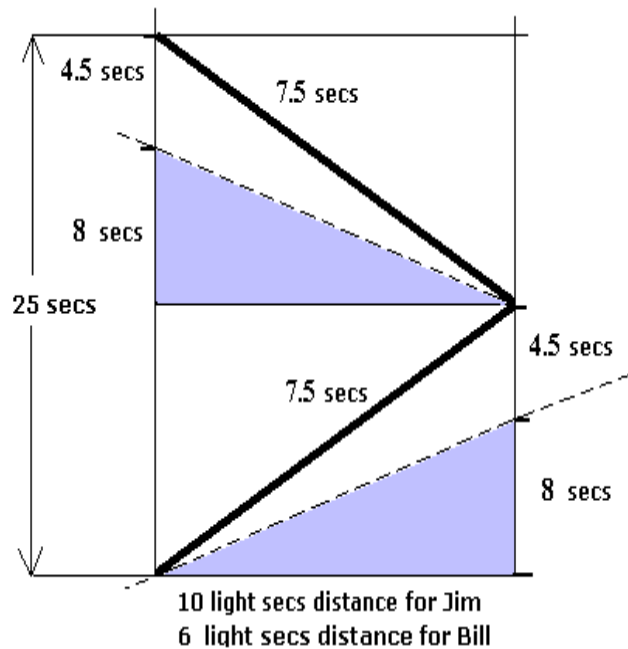

The time dilation in the twin paradox is symmetrical. Jim observes Bill's clocks go slow, reading only 15 secs change on Bill's clocks when his own read that 25 secs have passed. Bill observes only 9 secs elapse on Jim's clocks when his own show 15 secs have passed. However Bill also observes Jim's clocks jump by 16 secs as a result of phase making a total 25 secs for Jim's clocks.

From Bill's viewpoint there is both a time dilation and a phase effect. It is the added factor of "phase" that explains why, although the time dilation occurs for both observers, Bill observes the same readings on Jim's clocks over the whole journey as does Jim.

To summarise the mathematics of the twin paradox using the example:

Jim observes the distance as 10 light seconds and the distant point is in his frame of reference.

According to Jim it takes Bill the following time to make the journey:

Time taken = distance / velocity therefore according to Jim:

$$t = 10 / 0.8 = 12.5 \text{ seconds}$$

Again according to Jim, time dilation should affect the observed time on Bill's clocks:

$$T = t * \sqrt{1 - v^2/c^2} \text{ so:}$$

$$T = 12.5 * \sqrt{1 - 0.8^2} = 7.5 \text{ seconds}$$

So for Jim the round trip takes 25 secs and Bill's clock reads 15 secs.

Bill measures the distance as:

$$X = x * \sqrt{1 - v^2/c^2} = 10 * \sqrt{1 - 0.8^2} = 6 \text{ light seconds.}$$

For Bill it takes  $X / v = 6 / 0.8 = 7.5$  seconds.

Bill observes Jim's clocks to appear to run slow as a result of time dilation:

$$t' = T * \sqrt{1 - v^2/c^2} \text{ so:}$$

$$t' = 7.5 * \sqrt{1 - 0.8^2} = 4.5 \text{ seconds}$$

But there is also a time gap of  $vx / c^2 = 8$  seconds.

So for Bill, Jim's clocks register 12.5 secs have passed from the start to the distant point. This is composed of 4.5 secs elapsing on Jim's clocks plus an 8 sec time gap from the start of the journey. Bill sees 25 secs total time recorded on Jim's clocks over the whole journey, this is the same time as Jim observes on his own clocks.

It is sometimes dubiously asserted that the twin paradox is about the clocks on the twin that leaves earth being slower than those on the twin that stays at home, it is then argued that biological processes contain clocks therefore the twin that travelled away ages less. This is not really true because the relativistic phase plays a major role in the twin paradox and leads to Bill travelling to a remote place that, for Bill, is at a later time than Jim when Bill and Jim pass each other. A more

accurate explanation is that when we travel we travel in time as well as space.

The turn around is not required to demonstrate the twin "paradox". Suppose there were two travellers, Bill(1) who moves away from earth and Bill(2) who travels towards earth. If Bill(2) synchronises his clocks with the clocks on Bill(1) when they pass then the same difference in elapsed time between the clocks on Jim and Bill(2) will be observed as between Jim and Bill in the original example.

Students have difficulty with the twin paradox because they believe that the observations of the twins are symmetrical. This is not the case. As can be seen from the illustration below either twin could determine whether they had made the turn or the other twin had made the turn.

### The twin "paradox" is NOT symmetrical

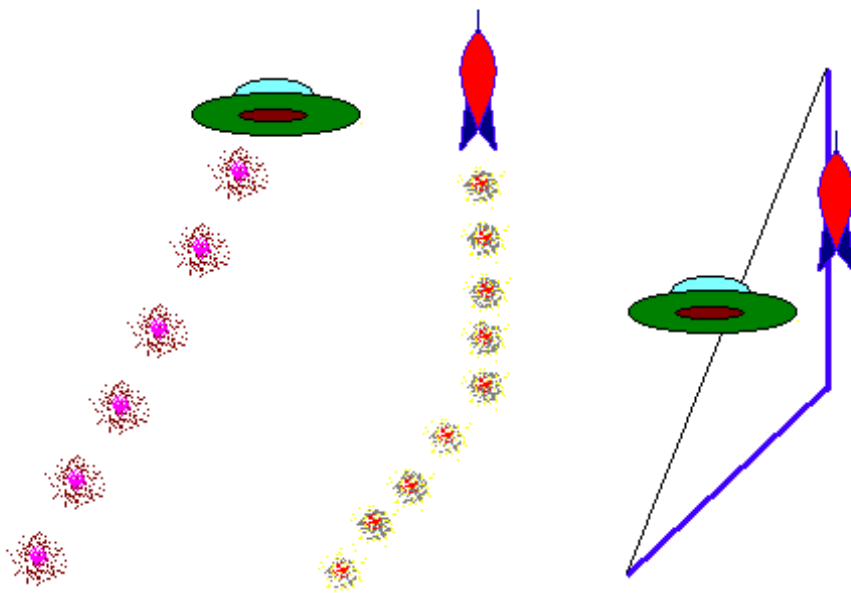

Two space ships have pulsatile ion drives that leave clouds of ions behind that glow in space. When they observe their trails it is clear who has followed which path. (They could also use accelerometers to make the same determination).

### Jim and Bill's view of the journey

Special relativity does not postulate that all motion is 'relative'; the postulates are that the laws of physics are the same in all inertial frames and there is a constant velocity called the "speed of light". Contrary to popular myth the twins do not observe events that are a mirror image of each other. Bill observes himself leave Jim then return, Jim sees Bill leave him then return. Bill does not observe Jim turn round, he observes himself making the turn.

The following illustrations cover various views of the journey. The most important moment in the journey is the point where Bill turns round. Notice how Bill's surface of simultaneity, that includes

the events that he considers to be in the present moment, swings across Jim's worldline during the turn.

### The turn round point

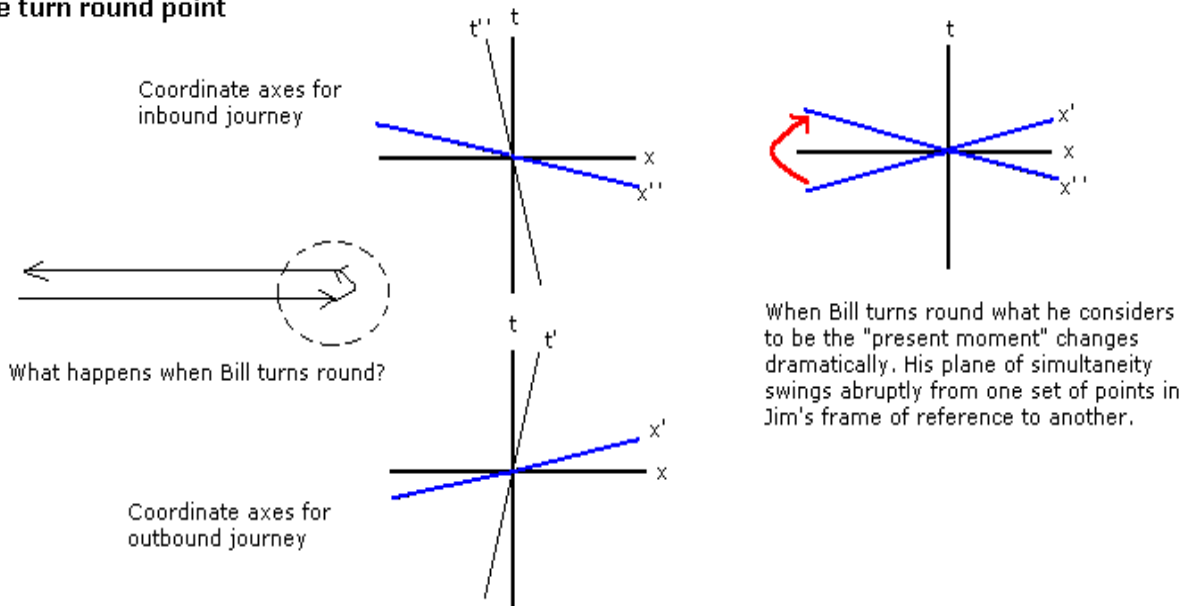

As Bill travels away from Jim he considers events that are already in Jim's past to be in his own present.

### Jim and Bill's view of the outbound journey

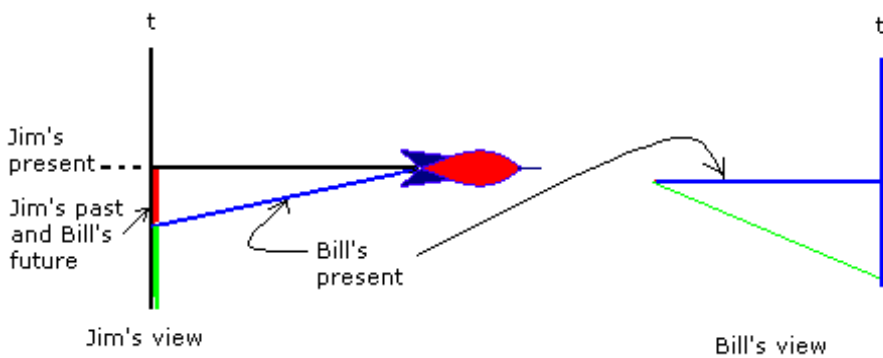

After the turn Bill considers events that are in Jim's future to be in his present (although the finite speed of light prevents Bill from observing Jim's future).

### Jim and Bill's view of the inbound journey

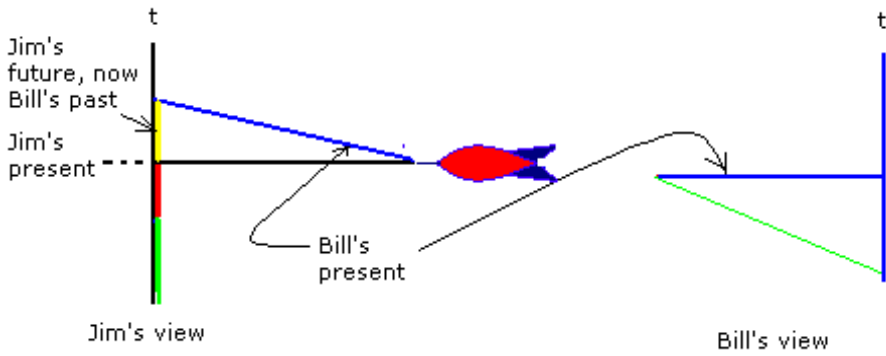

The swing in Bill's surface of simultaneity at the turn-round point leads to a 'time gap'. In our example Bill might surmise that Jim's clocks jump by 16 seconds on the turn.

### Jim and Bill's view of the turn - the time gap

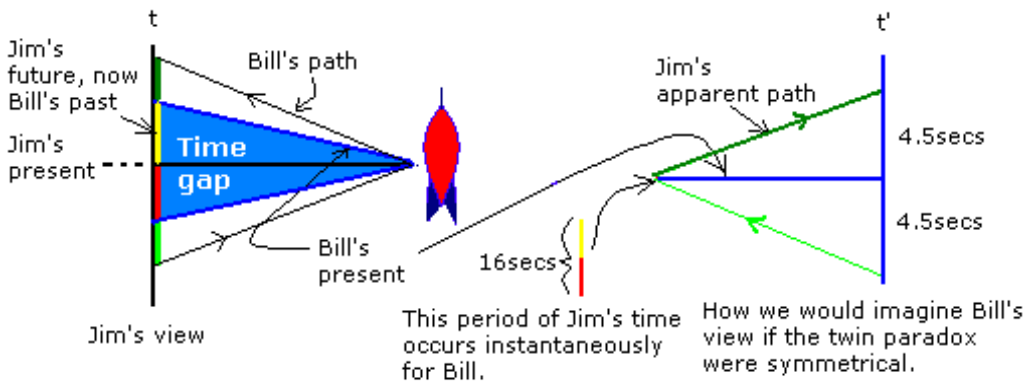

Notice that the term "Jim's apparent path" is used in the illustration - as was seen earlier, Bill knows that he himself has left Jim and returned so he knows that Jim's apparent path is an artefact of his own motion. If we imagine that the twin paradox is symmetrical then the illustration above shows how we might imagine Bill would view the journey. But what happens, in our example, to the 16 seconds in the time gap, does it just disappear? The twin paradox is not symmetrical and Jim does not make a sudden turn after 4.5 seconds. Bill's actual observation and the fate of the information in the time gap can be probed by supposing that Jim emits a pulse of light several times a second. The result is shown in the illustration below.

### Jim and Bill's view

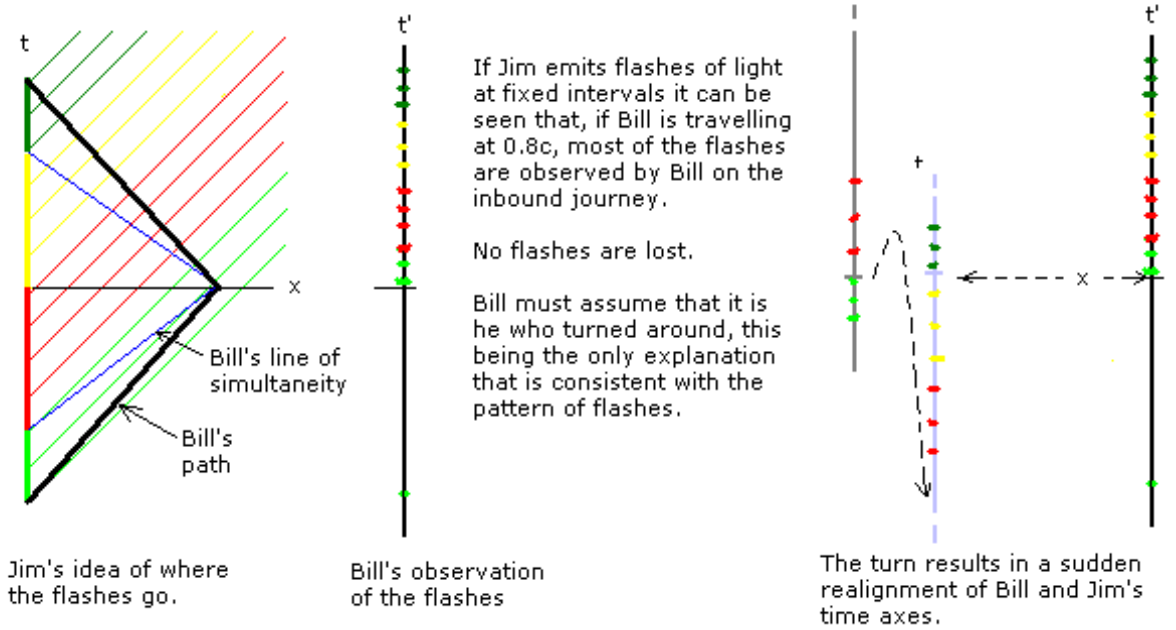

Jim has clearly but one inertial frame but does Bill represent a single inertial frame? Suppose Bill was on a planet as he passed Jim and flew back to Jim in a rocket from the turn-round point: how many inertial frames would be involved? Is Bill's view a view from a single inertial frame?

**Exercise:** it is interesting to calculate the observations made by an observer who continues in the direction of the outward leg of Bill's journey - note that a velocity transformation will be needed to estimate Bill's inbound velocity as measured by this third observer.

### The Pole-barn paradox

#### Length contraction as a result of the relativity of simultaneity

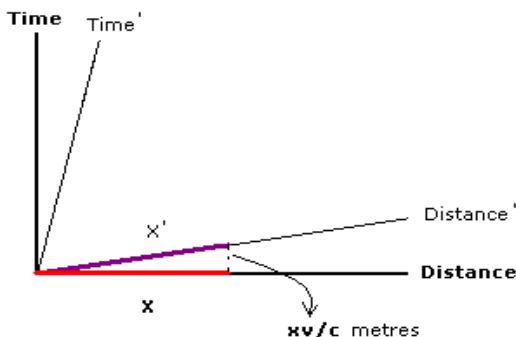

An observer picks up one of two identical rods and travels back past the other rod at high velocity ( $v$ ).

Using the Minkowskian metric:  $x'^2 = x^2 - (xv/c)^2$

Therefore:  $x' = x \sqrt{1 - v^2/c^2}$

#### Length contraction is symmetrical

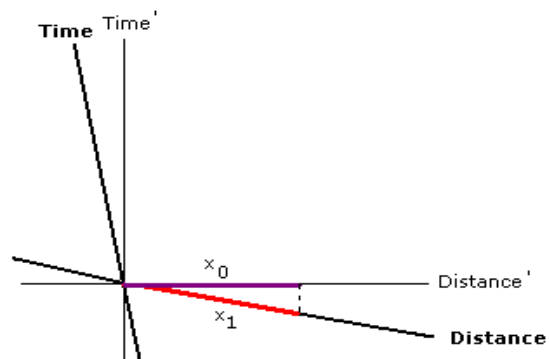

$x_1 = x_0 \sqrt{1 - v^2/c^2}$

The observer moving in the primed frame observes the REST length of his moving rod so gets the same contraction as the observer in the unprimed assigns when observing the rod in the primed frame.



(Note that Minkowski's metric involves the subtraction of displacements in time, so what appear to be the longest lengths on a 2D sheet of paper are often the shortest lengths in a (3+1)D reality).

The symmetry of length contraction leads to two questions. Firstly, how can a succession of events be observed as simultaneous events by another observer? This question led to the concept of de Broglie waves and quantum theory. Secondly, if a rod is simultaneously between two points in one frame how can it be observed as being successively between those points in another frame? For instance, if a pole enters a building at high speed how can one observer find it is fully within the building and another find that the two ends of the rod are opposed to the two ends of the building at successive times? What happens if the rod hits the end of the building? The second question is known as the "pole-barn paradox" or "ladder paradox".

### Pole-barn paradox

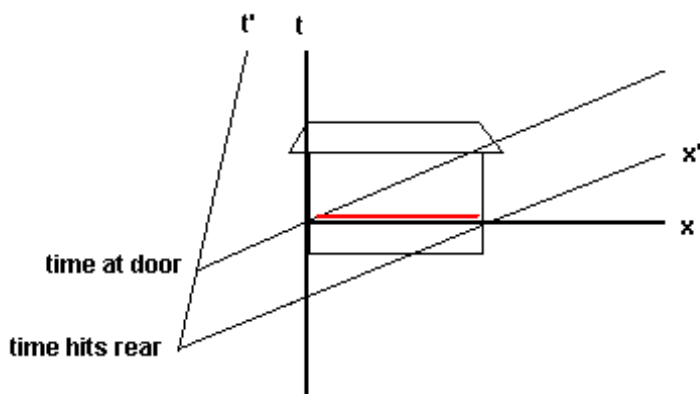

In the frame of the barn the pole is simultaneously at the rear of the barn and the door. In the frame of the pole these events occur sequentially.

The pole-barn paradox states the following: suppose a superhero running at  $0.75c$  and carrying a horizontal pole  $15\text{ m}$  long towards a barn  $10\text{ m}$  long, with front and rear doors. When the runner and the pole are inside the barn, a ground observer closes and then opens both doors (by remote control) so that the runner and pole are momentarily captured inside the barn and then proceed to exit the barn from the back door.

One may be surprised to see a  $15\text{-m}$  pole fit inside a  $10\text{-m}$  barn. But the pole is in motion with respect to the ground observer, who measures the pole to be contracted to a length of  $9.9\text{ m}$  (check using equations).

The "paradox" arises when we consider the runner's point of view. The runner sees the barn contracted to  $6.6\text{ m}$ . Because the pole is in the rest frame of the runner, the runner measures it to

have its proper length of 15 m. Now, how can our superhero make it safely through the barn?

The resolution of the “paradox” lies in the relativity of simultaneity. The closing of the two doors is measured to be simultaneous by the ground observer. However, since the doors are at different positions, the runner says that they do not close simultaneously. The rear door closes and then opens first, allowing the leading edge of the pole to exit. The front door of the barn does not close until the trailing edge of the pole passes by.

If the rear door is kept closed and made out of some impenetrable material then in the frame of the runner a shock wave will travel at the speed of light from the rear door that compresses the rod so that it fits within the barn. This shock wave will appear like an instantaneous explosion in the frame of the barn and a progressive wave in the frame of the runner.

## Addition of velocities

How can two observers, moving at  $v$  km/sec relative to each other, compare their observations of the velocity of a third object?

### Addition of velocities

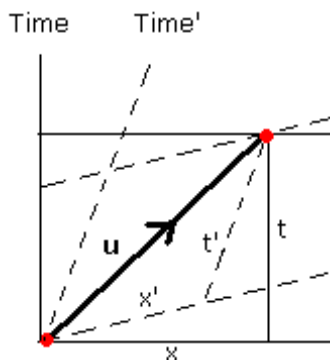

The velocity for one observer is given by:

$$u' = x' / t'$$

For the other observer it is given by:

$$u = x / t$$

Problem: find  $u$  in terms of  $u'$  and the relative velocity of the observers,  $v$ .

Suppose one of the observers measures the velocity of the object as  $u'$  where:

$$u' = \frac{x'}{t'}$$

The coordinates  $x'$  and  $t'$  are given by the Lorentz transformations:

$$x' = \frac{x - vt}{\sqrt{(1 - v^2/c^2)}}$$

and

$$t' = \frac{t - (v/c^2)x}{\sqrt{(1 - v^2/c^2)}}$$

but

$$x' = u't'$$

so:

$$\frac{x - vt}{\sqrt{(1 - v^2/c^2)}} = u' \frac{t - (v/c^2)x}{\sqrt{(1 - v^2/c^2)}}$$

and hence:

$$x - vt = u'(t - vx/c^2)$$

Notice the role of the phase term  $vx/c^2$ . The equation can be rearranged as:

$$x = \frac{(u' + v)}{(1 + u'v/c^2)}t$$

given that  $x = ut$ :

$$u = \frac{(u' + v)}{(1 + u'v/c^2)}$$

This is known as the **relativistic velocity addition theorem**, it applies to velocities parallel to the direction of mutual motion.

The existence of time dilation means that even when objects are moving perpendicular to the direction of motion there is a discrepancy between the velocities reported for an object by observers who are moving relative to each other. If there is any component of velocity in the x direction ( $u_x$ ,

$u'_x$ ) then the phase affects time measurement and hence the velocities perpendicular to the x-axis.

The table below summarises the relativistic addition of velocities in the various directions in space.

$u'_x = \frac{(u_x - v)}{(1 - u_x v/c^2)}$	$u_x = \frac{(u'_x + v)}{(1 + u'_x v/c^2)}$
$u'_y = \frac{u_y \sqrt{1 - v^2/c^2}}{(1 - u_x v/c^2)}$	$u_y = \frac{u'_y \sqrt{1 - v^2/c^2}}{(1 + u'_x v/c^2)}$
$u'_z = \frac{u_z \sqrt{1 - v^2/c^2}}{(1 - u_x v/c^2)}$	$u_z = \frac{u'_z \sqrt{1 - v^2/c^2}}{(1 + u'_x v/c^2)}$

Notice that for an observer in another reference frame the sum of two velocities ( $u$  and  $v$ ) can never exceed the speed of light. This means that the speed of light is the maximum velocity in any frame of reference.

## Relativistic Dynamics

The way that the velocity of a particle can differ between observers who are moving relative to each other means that momentum needs to be redefined as a result of relativity theory.

The illustration below shows a typical collision of two particles. In the right hand frame the collision is observed from the viewpoint of someone moving at the same velocity as one of the particles, in the left hand frame it is observed by someone moving at a velocity that is intermediate between those of the particles.

### Relativistic particle collisions

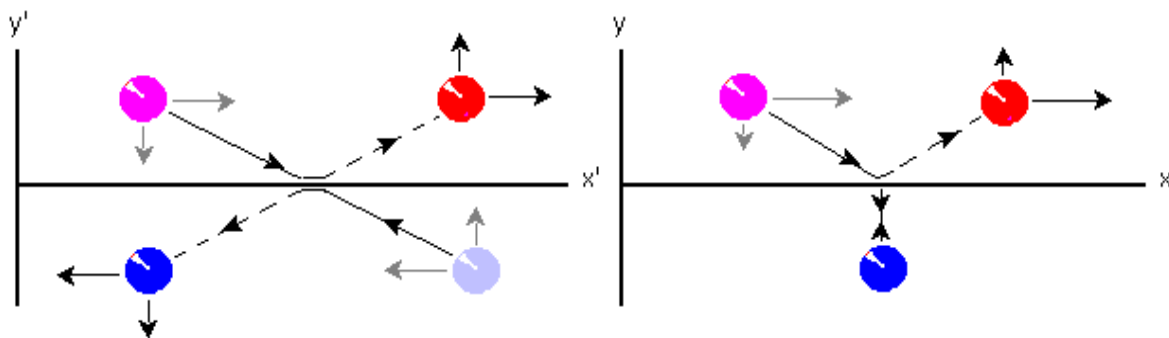

View of observer who is travelling at a velocity intermediate between that of the balls. (Red = +v Blue = -v Observer = 0 m/s)

View of observer travelling at same velocity as the blue ball.

If momentum is redefined then all the variables such as force (rate of change of momentum), energy etc. will become redefined and relativity will lead to an entirely new physics. The new physics has an effect at the ordinary level of experience through the relation  $E = mc^2$  whereby it is the tiny changes in relativistic mass that are expressed as everyday kinetic energy so that the whole of physics is related to "relativistic" reasoning rather than Newton's empirical ideas.

## Momentum

In physics momentum is conserved within a closed system, the **law of conservation of momentum** applies. Consider the special case of identical particles colliding symmetrically as illustrated below:

### A symmetrical Newtonian collision

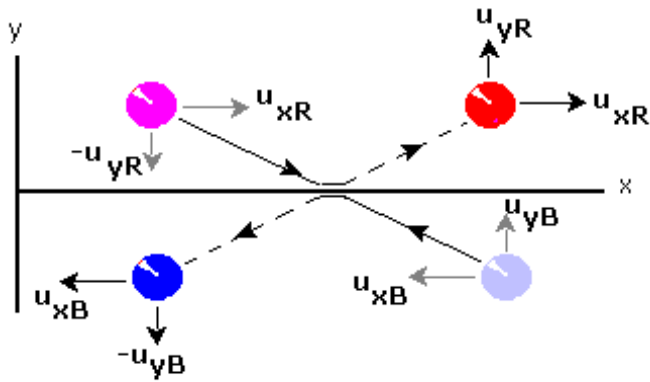

The momentum change by the red ball is:

$$2u_{yR}m$$

The momentum change by the blue ball is:

$$2u_{yB}m$$

The situation is symmetrical so the **Newtonian** conservation of momentum law is demonstrated:

$$2mu_{yR} = 2mu_{yB}$$

Notice that this result depends upon the y components of the velocities being equal ie:  $u_{yR} = u_{yB}$ .

The relativistic case is rather different. The collision is illustrated below, the left hand frame shows the collision as it appears for one observer and the right hand frame shows **exactly the same collision** as it appears for another observer moving at the same velocity as the blue ball:

### Relativistic particle collisions

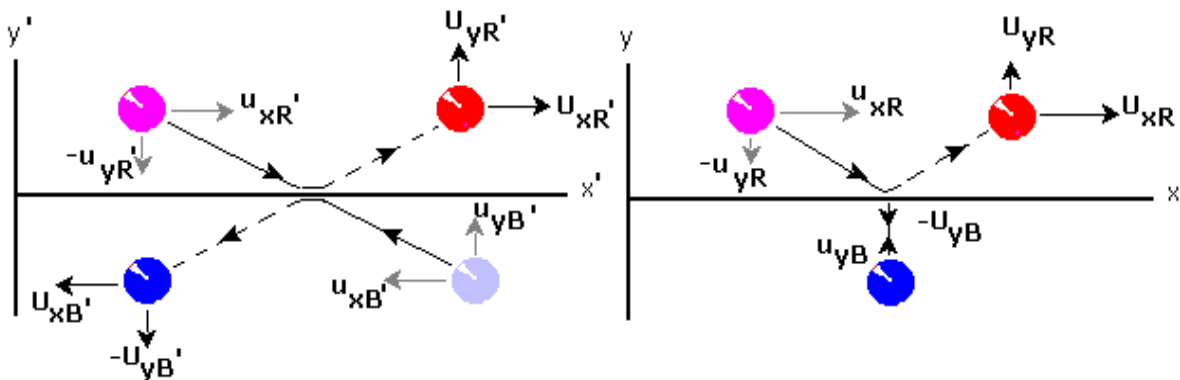

View of observer who is travelling at a velocity intermediate between that of the balls. (Red = +v Blue = -v Observer = 0 m/s)

View of observer travelling at same velocity as the blue ball.

The uppercase letters (U) represent velocities after the collision.

The configuration shown above has been simplified because one frame contains a stationary blue ball (ie:  $u_{xB} = 0$ ) and the velocities are chosen so that the vertical velocity of the red ball is exactly reversed after the

collision ie:  $u'_{yR} = -u'_{yB}$ . Both frames show exactly the same event, it is only the observers who differ between frames. The relativistic velocity transformations between frames is:

$$u'_{yR} = \frac{u_{yR} \sqrt{1 - v^2/c^2}}{1 - u_{xR}v/c^2}$$

$$u'_{yB} = u_{yB} \sqrt{1 - v^2/c^2} \text{ given that } u_{xB} = 0.$$

Suppose that the y components are equal in one frame, in Newtonian physics they will also be equal in the other frame. However, in relativity, if the y components are equal in one frame they are **not** necessarily equal

in the other frame. For instance if  $u'_{yR} = u'_{yB}$  then:

$$u_{yB} = \frac{u_{yR}}{1 - u_{xR}v/c^2}$$

So if  $u'_{yR} = u'_{yB}$  then in this case  $u_{yR} \neq u_{yB}$ .

If the mass were constant between collisions and between frames then although  $2m u'_{yR} = 2m u'_{yB}$  it is found that:

$$2m u_{yR} \neq 2m u_{yB}$$

So momentum defined as mass times velocity is not conserved in a collision when the collision is described in frames moving relative to each other. Notice that the discrepancy is very small if  $u_{xR}$  and  $v$  are small.

To preserve the principle of momentum conservation in all inertial reference frames, the definition of momentum has to be changed. The new definition must reduce to the Newtonian expression when objects move at speeds much smaller than the speed of light, so as to recover the Newtonian formulas.

The velocities in the y direction are related by the following equation when the observer is travelling at the same velocity as the blue ball ie: when  $u_{xB} = 0$ :

$$u_{yB} = \frac{u_{yR}}{1 - u_{xR}v/c^2}$$

If we write  $m_B$  for the mass of the blue ball) and  $m_R$  for the mass of the red ball as observed from the frame

of the blue ball then, if the principle of relativity applies:

$$2m_R u_{yR} = 2m_B u_{yB}$$

So:

$$m_R = m_B \frac{u_{yB}}{u_{yR}}$$

But:

$$u_{yB} = \frac{u_{yR}}{1 - u_{xR}v/c^2}$$

Therefore:

$$m_R = \frac{m_B}{1 - u_{xR}v/c^2}$$

This means that, if the principle of relativity is to apply then the mass must change by the amount shown in the equation above for the conservation of momentum law to be true.

The reference frame was chosen so that  $u'_{yR} = -u'_{yB}$  and hence  $u'_{xR} = v$ . This allows  $v$  to be determined in terms of  $u_{xR}$ :

$$u'_{xR} = \frac{u_{xR} - v}{1 - u_{xR}v/c^2} = v$$

and hence:

$$v = c^2/u_{xR}(1 - \sqrt{1 - u_{xR}^2/c^2})$$

So substituting for  $v$  in  $m_R = \frac{m_B}{1 - u_{xR}v/c^2}$ :

$$m_R = \frac{m_B}{\sqrt{1 - u_{xR}^2/c^2}}$$

The blue ball is at rest so its mass is sometimes known as its **rest mass**, and is given the symbol  $m_0$ . As the balls were identical at the start of the boost the mass of the red ball is the mass that a blue ball would have if it were in motion relative to an observer; this mass is sometimes known as the **relativistic mass** symbolised by  $m$ . These terms are now infrequently used in modern physics, as will be explained at the end of this section. The discussion given above was related to the relative motions of the blue and red balls, as a result  $u_{xR}$  corresponds to the **speed** of the moving ball relative to an observer who is stationary with respect to the



blue ball. These considerations mean that the relativistic mass is given by:

$$\mathbf{m} = \frac{\mathbf{m}_0}{\sqrt{1 - \mathbf{u}^2/c^2}}$$

The relativistic momentum is given by the product of the relativistic mass and the velocity  $\mathbf{P} = m\mathbf{u}$ .

The overall expression for momentum in terms of rest mass is:

$$\mathbf{P} = \frac{m_0 \mathbf{u}}{\sqrt{1 - u^2/c^2}}$$

and the components of the momentum are:

$$p_x = \frac{m_0 u_x}{\sqrt{1 - u^2/c^2}}$$

$$p_y = \frac{m_0 u_y}{\sqrt{1 - u^2/c^2}}$$

$$p_z = \frac{m_0 u_z}{\sqrt{1 - u^2/c^2}}$$

So the components of the momentum depend upon the appropriate velocity component and the speed.

Since the factor with the square root is cumbersome to write, the following abbreviation is often used, called the Lorentz gamma factor:

$$\gamma = \frac{1}{\sqrt{1 - u^2/c^2}}$$

The expression for the momentum then reads  $\mathbf{P} = m\gamma\mathbf{u}$ .

It can be seen from the discussion above that we can write the momentum of an object moving with velocity  $\mathbf{u}$  as the product of a function  $m(u)$  of the speed  $u$  and the velocity  $\mathbf{u}$ :

$$m(u)\mathbf{u}$$

The function  $m(u)$  must reduce to the object's mass  $m$  at small speeds, in particular when the object is at rest  $m(0) = m$ . The function  $m(u)$  used to be called 'relativistic mass', and its value in the frame of the particle was referred to as the 'rest mass' or 'invariant mass'. Both terms are now obsolete: the 'rest mass' is today simply called the mass, and the 'relativistic mass' is no longer used since, as will be seen in the discussion of energy below, it is identical to the energy but for the units.

## Force

Newton's second law states that the total force acting on a particle equals the rate of change of its momentum. The same form of Newton's second law holds in relativistic mechanics. The relativistic *3 force* is given by:

$$\mathbf{f} = d\mathbf{p}/dt$$

If the relativistic momentum is used:

$$\frac{d\mathbf{p}}{dt} = \frac{d(m\mathbf{u})}{dt}$$

By Leibniz's law where  $d(xy) = xdy + ydx$ :

$$\mathbf{f} = \frac{d\mathbf{p}}{dt} = m \frac{d\mathbf{u}}{dt} + \mathbf{u} \frac{dm}{dt}$$

This equation for force will be used below to derive relativistic expressions for the energy of a particle.

## Energy

Energy is defined as the work done in moving a body from one place to another. Energy is given from:

$$dE = \mathbf{f} d\mathbf{x}$$

so, over the whole path:

$$E = \int_0^x \mathbf{f} d\mathbf{x}$$

Kinetic energy (K) is the energy used to move a body from a velocity of 0 to a velocity  $\mathbf{u}$ . Restricting the motion to one dimension:

$$K = \int_{u=0}^{u=u} \mathbf{f} dx$$

Using the relativistic *3 force*:

$$K = \int_{u=0}^{u=u} \frac{d(m\gamma u)}{dt} dx$$

So:

$$K = \int_{u=0}^{u=u} m d(\gamma u) \frac{dx}{dt}$$

substituting for  $d(\gamma u)$  and using  $dx / dt = u$ :

$$K = \int_{u=0}^{u=u} m(\gamma du + u d\gamma)u$$

Which gives:

$$K = \int_{u=0}^{u=u} m(udu + u^2 d\gamma)$$

The Lorentz factor  $\gamma$  is given by:

$$\gamma = \frac{1}{\sqrt{1 - u^2/c^2}}$$

which can be expanded as:

$$\gamma^2 c^2 - \gamma^2 u^2 = c^2$$

Differentiating:

$$2\gamma c^2 d\gamma - \gamma^2 2udu - u^2 2\gamma d\gamma = 0$$

So, rearranging:

$$\gamma u du + u^2 d\gamma = c^2 d\gamma$$

In which case:

$$K = \int_{u=0}^{u=u} m(udu + u^2 d\gamma)$$

is simplified to:

$$K = \int_{u=0}^{u=u} mc^2 d\gamma$$

As  $u$  goes from 0 to  $u$ , the Lorentz factor  $\gamma$  goes from 1 to  $\gamma$ , so:

$$K = mc^2 \int_{\gamma=1}^{\gamma=\gamma} d\gamma$$

and hence:

$$K = \gamma mc^2 - mc^2$$

The amount  $\gamma mc^2$  is known as the **total energy** of the particle. The amount  $mc^2$  is known as the **rest energy** of the particle. If the total energy of the particle is given the symbol  $E$ :

$$E = \gamma mc^2 = mc^2 + K$$

So it can be seen that  $mc^2$  is the energy of a mass that is stationary. This energy is known as **mass energy** and is the origin of the famous formula  $E = mc^2$  that is iconic of the nuclear age.

The Newtonian approximation for kinetic energy can be derived by using the binomial theorem to expand

$$\gamma = (1 - u^2/c^2)^{-\frac{1}{2}}$$

The binomial theorem is:

$$(a + x)^n = a^n + na^{n-1}x + \frac{n(n-1)}{2!}a^{n-2}x^2 \dots$$

So expanding  $(1 - u^2/c^2)^{-\frac{1}{2}}$ :

$$K = \frac{1}{2}mu^2 + \frac{3mu^4}{8c^2} + \frac{5mv^6}{16c^4} + \dots$$

So if  $u$  is much less than  $c$ :

$$K = \frac{1}{2}mu^2$$

which is the Newtonian approximation for low velocities.

## Nuclear Energy

When protons and neutrons (nucleons) combine to form elements the combination of particles tends to be in a lower energy state than the free neutrons and protons. Iron has the lowest energy and elements above and below iron in the scale of atomic masses tend to have higher energies. This decrease in energy as neutrons and protons bind together is known as the **binding energy**. The atomic masses of elements are slightly different from that calculated from their constituent particles and this difference in mass energy, calculated from  $E = mc^2$ , is almost exactly equal to the binding energy.

The binding energy can be released by converting elements with higher masses per nucleon to those with lower masses per nucleon. This can be done by either splitting heavy elements such as uranium into lighter elements such as barium and krypton or by joining together light elements such as hydrogen into heavier elements such as deuterium. If atoms are split the process is known as **nuclear fission** and if atoms are joined the process is known as **nuclear fusion**. Atoms that are lighter than iron can be fused to release energy and those heavier than iron can be split to release energy.

When hydrogen and a neutron are combined to make deuterium the energy released can be calculated as follows:

The mass of a proton is 1.00731 amu, the mass of a neutron is 1.00867 amu and the mass of a deuterium nucleus is 2.0136 amu. The difference in mass between a deuterium nucleus and its components is 0.00238 amu. The energy of this mass difference is:

$$E = mc^2 = 1.66 \times 10^{-27} \times 0.00238 \times (3 \times 10^8)^2$$

So the energy released is  $3.57 \times 10^{-13}$  joules or about  $2 \times 10^{11}$  joules per gram of protons (ionised hydrogen).

(Assuming 1 amu =  $1.66 \times 10^{-27}$  Kg, Avogadro's number =  $6 \times 10^{23}$  and the speed of light is  $3 \times 10^8$  metres per second)

Present day nuclear reactors use a process called **nuclear fission** in which rods of uranium emit neutrons which combine with the uranium in the rod to produce uranium isotopes such as  $^{236}\text{U}$  which rapidly decay into smaller nuclei such as Barium and Krypton plus three neutrons which can cause further generation of  $^{236}\text{U}$  and further decay. The fact that each neutron can cause the generation of three more neutrons means that a self sustaining or **chain reaction** can occur. The generation of energy results from the equivalence of mass and energy; the decay products, barium and krypton have a lower mass than the original  $^{236}\text{U}$ , the missing mass being released as 177 MeV of radiation. The nuclear equation for the decay of  $^{236}\text{U}$  is written as follows:

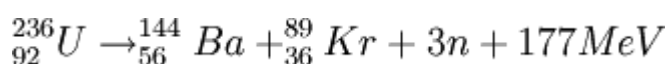

Nuclear explosion

If a large amount of the uranium isotope  $^{235}\text{U}$  (the **critical mass**) is confined the chain reaction can get out of control and almost instantly release a large amount of energy. A device that confines a

critical mass of uranium is known as an **atomic bomb** or **A-bomb**. A bomb based on the fusion of deuterium atoms is known as a **thermonuclear bomb**, **hydrogen bomb** or **H-bomb**.

## Light propagation and the aether

Many students confuse Relativity Theory with a theory about the propagation of light. According to modern Relativity Theory the constancy of the speed of light is a consequence of the geometry of spacetime rather than something specifically due to the properties of photons; but the statement "the speed of light is constant" often distracts the student into a consideration of light propagation. This confusion is amplified by the importance assigned to interferometry experiments, such as the Michelson-Morley experiment, in most textbooks on Relativity Theory.

The history of theories of the propagation of light is an interesting topic in physics and was indeed important in the early days of Relativity Theory. In the seventeenth century two competing theories of light propagation were developed. Christiaan Huygens published a **wave theory of light** which was based on **Huygen's principle** whereby every point in a wavelike disturbance can give rise to further disturbances that spread out spherically. In contrast Newton considered that the propagation of light was due to the passage of small particles or "corpuscles" from the source to the illuminated object. His theory is known as the **corpuscular theory of light**. Newton's theory was widely accepted until the nineteenth century.

In the early nineteenth century Thomas Young performed his **Young's slits** experiment and the interference pattern that occurred was explained in terms of diffraction due to the wave nature of light. The wave theory was accepted generally until the twentieth century when quantum theory confirmed that light had a corpuscular nature and that Huygen's principle could not be applied.

The idea of light as a disturbance of some medium, or **aether**, that permeates the universe was problematical from its inception (US spelling: "ether"). The first problem that arose was that the speed of light did not change with the velocity of the observer. If light were indeed a disturbance of some stationary medium then as the earth moves through the medium towards a light source the speed of light should appear to increase. It was found however that the speed of light did not change as expected. Each experiment on the velocity of light required corrections to existing theory and led to a variety of subsidiary theories such as the "aether drag hypothesis". Ultimately it was experiments that were designed to investigate the properties of the aether that provided the first experimental evidence for Relativity Theory.

### The aether drag hypothesis

The **aether drag hypothesis** was an early attempt to explain the way experiments such as Arago's experiment showed that the speed of light is constant. The aether drag hypothesis is now considered to be incorrect by mainstream science.

According to the aether drag hypothesis light propagates in a special medium, the aether, that remains attached to things as they move. If this is the case then, no matter how fast the earth moves around the sun or

rotates on its axis, light on the surface of the earth would travel at a constant velocity.

The primary reason the aether drag hypothesis is considered invalid is because of the occurrence of stellar aberration. In stellar aberration the position of a star when viewed with a telescope swings each side of a central position by about 20.5 seconds of arc every six months. This amount of swing is the amount expected when considering the speed of earth's travel in its orbit. In 1871 George Biddell Airy demonstrated that stellar aberration occurs even when a telescope is filled with water. It seems that if the aether drag hypothesis were true then stellar aberration would not occur because the light would be travelling in the aether which would be moving along with the telescope.

### Stellar Aberration

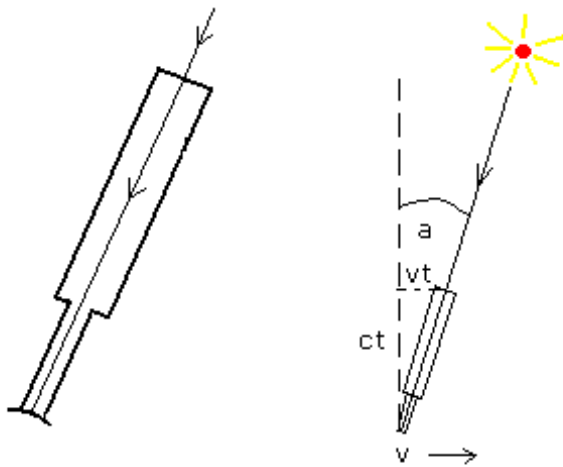

$$\tan(a) = vt/ct$$

If a telescope is travelling at high speed only light that is arranged at a particular angle can avoid hitting the walls of the telescope tube

If you visualize a bucket on a train about to enter a tunnel and a drop of water drips from the tunnel entrance into the bucket at the very centre, the drop will not hit the centre at the bottom of the bucket. The bucket is the tube of a telescope, the drop is a photon and the train is the earth. If aether is dragged then the droplet would be travelling with the train when it is dropped and would hit the centre of bucket at the bottom.

The amount of stellar aberration,  $\alpha$  is given by:

$$\tan(\alpha) = v\delta t / c\delta t$$

So:

$$\tan(\alpha) = v / c$$

The speed at which the earth goes round the sun,  $v = 30$  km/s, and the speed of light is  $c = 300,000,000$  m/s which gives  $\alpha = 20.5$  seconds of arc every six months. This amount of aberration is observed and this contradicts the aether drag hypothesis.



In 1818 Fresnel introduced a modification to the aether drag hypothesis that only applies to the interface between media. This was accepted during much of the nineteenth century but has now been replaced by special theory of relativity (see below).

The aether drag hypothesis is historically important because it was one of the reasons why Newton's corpuscular theory of light was replaced by the wave theory and it is used in early explanations of light propagation without relativity theory. It originated as a result of early attempts to measure the speed of light.

In 1810 François Arago realised that variations in the refractive index of a substance predicted by the corpuscular theory would provide a useful method for measuring the velocity of light. These predictions arose because the refractive index of a substance such as glass depends on the ratio of the velocities of light in air and in the glass. Arago attempted to measure the extent to which corpuscles of light would be refracted by a glass prism at the front of a telescope. He expected that there would be a range of different angles of refraction due to the variety of different velocities of the stars and the motion of the earth at different times of the day and year. Contrary to this expectation he found that there was no difference in refraction between stars, between times of day or between seasons. All Arago observed was ordinary stellar aberration.

In 1818 Augustin Jean Fresnel examined Arago's results using a wave theory of light. He realised that even if light were transmitted as waves the refractive index of the glass-air interface should have varied as the glass moved through the aether to strike the incoming waves at different velocities when the earth rotated and the seasons changed.

Fresnel proposed that the glass prism would carry some of the aether along with it so that "...the aether is in excess inside the prism". He realised that the velocity of propagation of waves depends on the density of the medium so proposed that the velocity of light in the prism would need to be adjusted by an amount of 'drag'.

The velocity of light  $v_n$  in the glass without any adjustment is given by:

$$v_n = c / n$$

The drag adjustment  $v_d$  is given by:

$$v_d = v \left( 1 - \frac{\rho_e}{\rho_g} \right)$$

Where  $\rho_e$  is the aether density in the environment,  $\rho_g$  is the aether density in the glass and  $v$  is the velocity of the prism with respect to the aether.

The factor  $\left( 1 - \frac{\rho_e}{\rho_g} \right)$  can be written as  $\left( 1 - \frac{1}{n^2} \right)$  because the refractive index,  $n$ , would be dependent on the density of the aether. This is known as the **Fresnel drag coefficient**.

The velocity of light in the glass is then given by:

$$V = \frac{c}{n} + v\left(1 - \frac{1}{n^2}\right)$$

This correction was successful in explaining the null result of Arago's experiment. It introduces the concept of a largely stationary aether that is dragged by substances such as glass but not by air. Its success favoured the wave theory of light over the previous corpuscular theory.

The Fresnel drag coefficient was confirmed by an interferometer experiment performed by Fizeau. Water was passed at high speed along two glass tubes that formed the optical paths of the interferometer and it was found that the fringe shifts were as predicted by the drag coefficient.

### The Fizeau Experiment

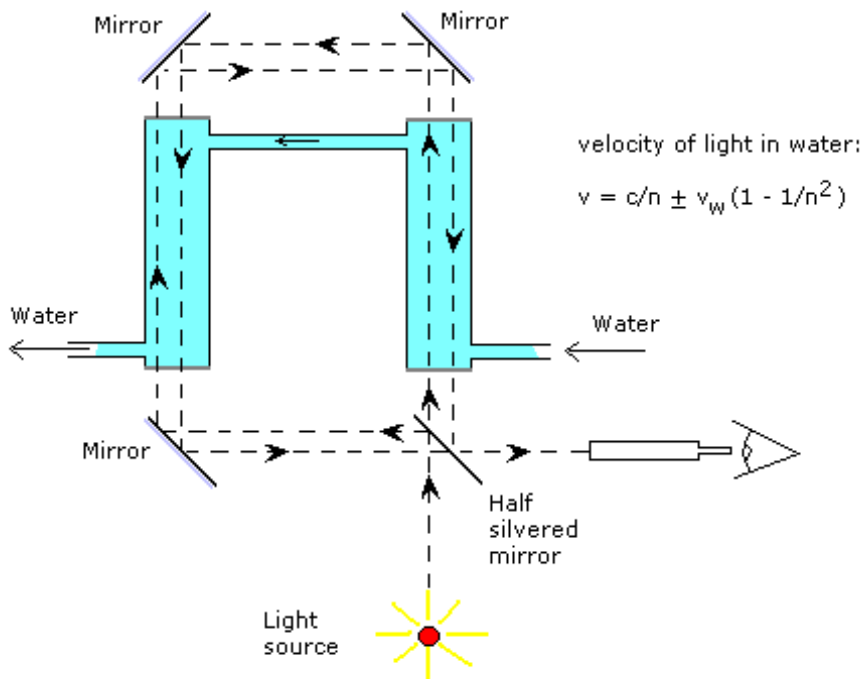

The special theory of relativity predicts the result of the Fizeau experiment from the velocity addition theorem without any need for an aether.

If  $V$  is the velocity of light relative to the Fizeau apparatus and  $U$  is the velocity of light relative to the water and  $v$  is the velocity of the water:

$$U = \frac{c}{n}$$

$$V = \frac{c/n + v}{1 + v/n c}$$

which, if  $v/c$  is small can be expanded using the binomial expansion to become:

$$V = \frac{c}{n} + v\left(1 - \frac{1}{n^2}\right)$$

This is identical to Fresnel's equation.

It may appear as if Fresnel's analysis can be substituted for the relativistic approach, however, more recent work has shown that Fresnel's assumptions should lead to different amounts of aether drag for different frequencies of light and violate Snell's law (see Ferraro and Sforza (2005)).

The aether drag hypothesis was one of the arguments used in an attempt to explain the Michelson-Morley experiment before the widespread acceptance of the special theory of relativity.

The Fizeau experiment is consistent with relativity and approximately consistent with each individual body, such as prisms, lenses etc. dragging its own aether with it. This contradicts some modified versions of the aether drag hypothesis that argue that aether drag may happen on a global (or larger) scale and stellar aberration is merely transferred into the entrained "bubble" around the earth which then faithfully carries the modified angle of incidence directly to the observer.

## References

- [Rafael Ferraro and Daniel M Sforza 2005. Arago \(1810\): the first experimental result against the ether Eur. J. Phys. 26 195-204](#)

## The Michelson-Morley experiment

The **Michelson-Morley experiment**, one of the most important and famous experiments in the history of physics, was performed in 1887 by Albert Michelson and Edward Morley at what is now Case Western Reserve University, and is considered to be the first strong evidence against the theory of a luminiferous aether.

Physics theories of the late 19th century postulated that, just as water waves must have a medium to move across (water), and audible sound waves require a medium to move through (air), so also light waves require a medium, the "luminiferous aether". The speed of light being so great, designing an experiment to detect the presence and properties of this aether took considerable thought.

## Measuring aether

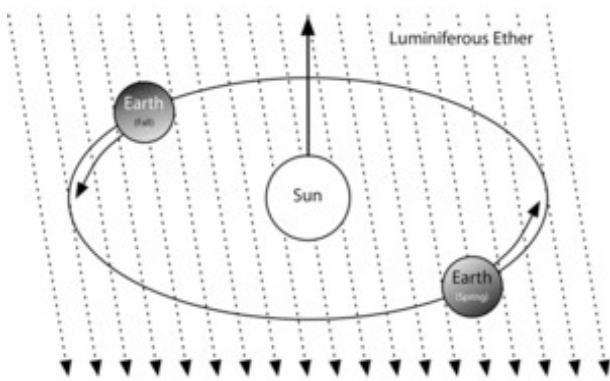

A depiction of the concept of the "aether wind".

Each year, the Earth travels a tremendous distance in its orbit around the sun, at a speed of around 30 km/second, over 100,000 km per hour. It was reasoned that the Earth would at all times be moving through the aether and producing a detectable "aether wind". At any given point on the Earth's surface, the magnitude and direction of the wind would vary with time of day and season. By analysing the effective wind at various different times, it should be possible to separate out components due to motion of the Earth relative to the Solar System from any due to the overall motion of that system.

The effect of the aether wind on light waves would be like the effect of wind on sound waves. Sound waves travel at a constant speed relative to the medium that they are travelling through (this varies depending on the pressure, temperature etc (see sound), but is typically around 340 m/s). So, if the speed of sound in our conditions is 340 m/s, when there is a 10 m/s wind relative to the ground, into the wind it will appear that sound is travelling at 330 m/s ( $340 - 10$ ). Downwind, it will appear that sound is travelling at 350 m/s ( $340 + 10$ ). Measuring the speed of sound compared to the ground in different directions will therefore enable us to calculate the speed of the air relative to the ground.

If the speed of the sound cannot be directly measured, an alternative method is to measure the time that the sound takes to bounce off of a reflector and return to the origin. This is done parallel to the wind and perpendicular (since the direction of the wind is unknown before hand, just determine the time for several different directions). The cumulative round trip effects of the wind in the two orientations slightly favors the sound travelling at right angles to it. Similarly, the effect of an aether wind on a beam of light would be for the beam to take slightly longer to travel round-trip in the direction parallel to the "wind" than to travel the same round-trip distance at right angles to it.

"Slightly" is key, in that, over a distance such as a few meters, the difference in time for the two round trips would be only about a millionth of a millionth of a second. At this point the only truly accurate measurements of the speed of light were those carried out by Albert Abraham Michelson, which had resulted in measurements accurate to a few meters per second. While a stunning achievement in its own right, this

was certainly not nearly enough accuracy to be able to detect the aether.

## The experiments

Michelson, though, had already seen a solution to this problem. His design, later known as an interferometer, sent a single source of white light through a half-silvered mirror that was used to split it into two beams travelling at right angles to one another. After leaving the splitter, the beams travelled out to the ends of long arms where they were reflected back into the middle on small mirrors. They then recombined on the far side of the splitter in an eyepiece, producing a pattern of constructive and destructive interference based on the length of the arms. Any slight change in the amount of time the beams spent in transit would then be observed as a shift in the positions of the interference fringes. If the aether were stationary relative to the sun, then the Earth's motion would produce a shift of about 0.04 fringes.

Michelson had made several measurements with an experimental device in 1881, in which he noticed that the expected shift of 0.04 was not seen, and a smaller shift of about 0.02 was. However his apparatus was a prototype, and had experimental errors far too large to say anything about the aether wind. For a measurement of the aether wind, a much more accurate and tightly controlled experiment would have to be carried out. The prototype was, however, successful in demonstrating that the basic method was feasible.

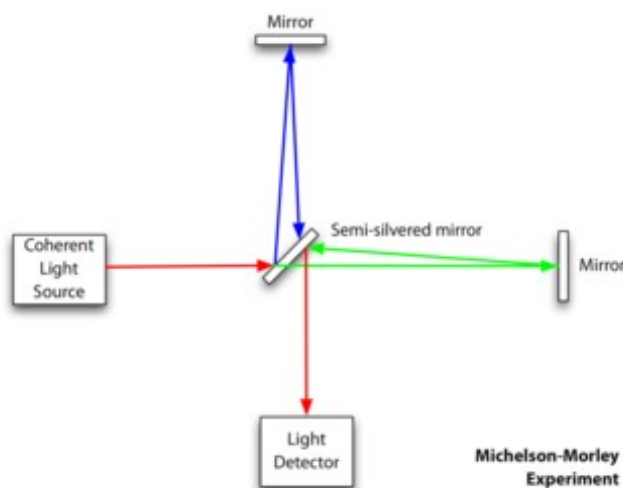

A Michelson interferometer

He then combined forces with Edward Morley and spent a considerable amount of time and money creating an improved version with more than enough accuracy to detect the drift. In their experiment the light was repeatedly reflected back and forth along the arms, increasing the path length to 11m. At this length the drift would be about .4 fringes. To make that easily detectable the apparatus was located in a closed room in the basement of a stone building, eliminating most thermal and vibrational effects. Vibrations were further reduced by building the apparatus on top of a huge block of marble, which was then floated in a pool of mercury. They calculated that effects of about 1/100th of a fringe would be detectable.

The mercury pool allowed the device to be turned, so that it could be rotated through the entire range of possible angles to the "aether wind". Even over a short period of time some sort of effect would be noticed simply by rotating the device, such that one arm rotated into the direction of the wind and the other away. Over longer periods day/night cycles or yearly cycles would also be easily measurable.

During each full rotation of the device, each arm would be parallel to the wind twice (facing into and away from the wind) and perpendicular to the wind twice. This effect would show readings in a sine wave formation with two peaks and two troughs. Additionally if the wind was only from the earth's orbit around the sun, the wind would fully change directions east/west during a 12 hour period. In this ideal conceptualization, the sine wave of day/night readings would be in opposite phase.

Because it was assumed that the motion of the solar system would cause an additional component to the wind, the yearly cycles would be detectable as an alteration of the magnitude of the wind. An example of this effect is a helicopter flying forward. While on the ground, a helicopter's blades would be measured as travelling around at 50 MPH at the tips. However, if the helicopter is travelling forward at 50 MPH, there are points at which the tips of the blades are travelling 0 MPH and 100 MPH with respect to the air they are travelling through. This increases the magnitude of the lift on one side and decreases it on the other just as it would increase and decrease the magnitude of an ether wind on a yearly basis.

### **The most famous failed experiment**

Ironically, after all this thought and preparation, the experiment became what might be called the most famous failed experiment to date. Instead of providing insight into the properties of the aether, Michelson and Morley's [1887 article](#) in the American Journal of Science reported the measurement to be as small as one-fortieth of the expected displacement but "since the displacement is proportional to the square of the velocity" they concluded that the measured velocity was approximately one-sixth of the expected velocity of the Earth's motion in orbit and "certainly less than one-fourth". Although this small "velocity" was measured, it was considered far too small to be used as evidence of aether, it was later said to be within the range of an experimental error that would allow the speed to actually be zero.

Although Michelson and Morley went on to different experiments after their first publication in 1887, both remained active in the field. Other versions of the experiment were carried out with increasing sophistication. Kennedy and Illingsworth both modified the mirrors to include a half-wave "step", eliminating the possibility of some sort of standing wave pattern within the apparatus. Illingsworth could detect changes on the order of 1/300th of a fringe, Kennedy up to 1/1500th. Miller later built a non-magnetic device to eliminate magnetostriction, while Michelson built one of non-expanding invar to eliminate any remaining thermal effects. Others from around the world increased accuracy, eliminated possible side effects, or both. All of these with the exception of Dayton Miller also returned what is considered a null result.

Morley was not convinced of his own results, and went on to conduct additional experiments with Dayton

Miller. Miller worked on increasingly large experiments, culminating in one with a 32m (effective) arm length at an installation at the Mount Wilson observatory. To avoid the possibility of the aether wind being blocked by solid walls, he used a special shed with thin walls, mainly of canvas. He consistently measured a small positive effect that varied, as expected, with each rotation of the device, the sidereal day and on a yearly basis. The low magnitude of the results he attributed to aether entrainment (see below). His measurements amounted to only ~10 kps instead of the expected ~30 kps expected from the earth's orbital motion alone. He remained convinced this was due to *partial* entrainment, though he did not attempt a detailed explanation.

Though Kennedy later also carried out an experiment at Mount Wilson, finding 1/10 the drift measured by Miller, and no seasonal effects, Miller's findings were considered important at the time, and were discussed by Michelson, Hendrik Lorentz and others at a meeting reported in 1928 (ref below). There was general agreement that more experimentation was needed to check Miller's results. Lorentz recognised that the results, whatever their cause, did not quite tally with either his or Einstein's versions of special relativity. Einstein was not present at the meeting and felt the results could be dismissed as experimental error (see Shankland ref below).

Name	Year	Arm length (meters)	Fringe shift expected	Fringe shift measured	Experimental Resolution	Upper Limit on $V_{\text{aether}}$
Michelson	1881	1.2	0.04	0.02		
Michelson and Morley	1887	11.0	0.4	< 0.01		8 km/s
Morley and Morley	1902–1904	32.2	1.13	0.015		
Miller	1921	32.0	1.12	0.08		
Miller	1923–1924	32.0	1.12	0.03		
Miller (Sunlight)	1924	32.0	1.12	0.014		
Tomascheck (Starlight)	1924	8.6	0.3	0.02		
Miller (Mt Wilson)	1925–1926	32.0	1.12	0.088		
Illingworth	1926	2.0	0.07	0.002	0.0006	1 km/s
Piccard and Stahel (Rigi)	1927	2.8	0.13	0.006		
Michelson et al.	1929	25.9	0.9	0.01		
Joos	1930	21.0	0.75	0.002		

In recent times versions of the MM experiment have become commonplace. Lasers and masers amplify light

by repeatedly bouncing it back and forth inside a carefully tuned cavity, thereby inducing high-energy atoms in the cavity to give off more light. The result is an effective path length of kilometers. Better yet, the light emitted in one cavity can be used to start the same cascade in another set at right angles, thereby creating an interferometer of extreme accuracy.

The first such experiment was led by Charles H. Townes, one of the co-creators of the first maser. Their 1958 experiment put an upper limit on drift, including any possible experimental errors, of only 30 m/s. In 1974 a repeat with accurate lasers in the triangular Trimmer experiment reduced this to 0.025 m/s, and included tests of entrainment by placing one leg in glass. In 1979 the Brillet-Hall experiment put an upper limit of 30 m/s for any one direction, but reduced this to only 0.000001 m/s for a two-direction case (ie, still or partially entrained aether). A year long repeat known as Hils and Hall, published in 1990, reduced this to  $2 \times 10^{-13}$ .

## **Fallout**

This result was rather astounding and not explainable by the then-current theory of wave propagation in a static aether. Several explanations were attempted, among them, that the experiment had a hidden flaw (apparently Michelson's initial belief), or that the Earth's gravitational field somehow "dragged" the aether around with it in such a way as locally to eliminate its effect. Miller would have argued that, in most if not all experiments other than his own, there was little possibility of detecting an aether wind since it was almost completely blocked out by the laboratory walls or by the apparatus itself. Be this as it may, the idea of a simple aether, what became known as the *First Postulate*, had been dealt a serious blow.

A number of experiments were carried out to investigate the concept of aether dragging, or *entrainment*. The most convincing was carried out by Hamar, who placed one arm of the interferometer between two huge lead blocks. If aether were dragged by mass, the blocks would, it was theorised, have been enough to cause a visible effect. Once again, no effect was seen.

Walter Ritz's Emission theory (or ballistic theory), was also consistent with the results of the experiment, not requiring aether, more intuitive and paradox-free. This became known as the *Second Postulate*. However it also led to several "obvious" optical effects that were not seen in astronomical photographs, notably in observations of binary stars in which the light from the two stars could be measured in an interferometer.

The Sagnac experiment placed the MM apparatus on a constantly rotating turntable. In doing so any ballistic theories such as Ritz's could be tested directly, as the light going one way around the device would have different length to travel than light going the other way (the eyepiece and mirrors would be moving toward/away from the light). In Ritz's theory there would be no shift, because the net velocity between the light source and detector was zero (they were both mounted on the turntable). However in this case an effect *was* seen, thereby eliminating any simple ballistic theory. This fringe-shift effect is used today in laser gyroscopes.



Another possible solution was found in the Lorentz-FitzGerald contraction hypothesis. In this theory all objects physically contract along the line of motion relative to the aether, so while the light may indeed transit slower on that arm, it also ends up travelling a shorter distance that exactly cancels out the drift.

In 1932 the Kennedy-Thorndike experiment modified the Michelson-Morley experiment by making the path lengths of the split beam unequal, with one arm being very long. In this version the two ends of the experiment were at different velocities due to the rotation of the earth, so the contraction would not "work out" to exactly cancel the result. Once again, no effect was seen.

Ernst Mach was among the first physicists to suggest that the experiment actually amounted to a disproof of the aether theory. The development of what became Einstein's special theory of relativity had the Fitzgerald-Lorentz contraction derived from the invariance postulate, and was also consistent with the apparently null results of most experiments (though not, as was recognised at the 1928 meeting, with Miller's observed seasonal effects). Today relativity is generally considered the "solution" to the MM null result.

The Trouton-Noble experiment is regarded as the electrostatic equivalent of the Michelson-Morley optical experiment, though whether or not it can ever be done with the necessary sensitivity is debatable. On the other hand, the 1908 Trouton-Rankine experiment that spelled the end of the Lorentz-FitzGerald contraction hypothesis achieved an incredible sensitivity.

## References

- [W. Ritz, Recherches Critiques sur l'Electrodynamique Generale, \*Ann. Chim., Phys.\*, 13, 145, \(1908\) - English Translation](#)
- [W. de Sitter, Ein astronomischer Beweis für die Konstanz der Lichtgeschwindigkeit, \*Physik. Zeitschr.\*, 14, 429 \(1913\)](#)
- [The Michelson Morley and the Kennedy Thorndike tests of STR](#)
- [The Trouton-Rankine Experiment and the Refutation of the FitzGerald Contraction](#)
- [High Speed Ives-Stilwell Experiment Used to Disprove the Emission Theory](#)

## Mathematical analysis of the Michelson Morley Experiment

The Michelson interferometer splits light into rays that travel along two paths then recombines them. The recombined rays interfere with each other. If the path length changes in one of the arms the interference pattern will shift slightly, moving relative to the cross hairs in the telescope. The Michelson interferometer is arranged as an optical bench on a concrete block that floats on a large pool of mercury. This allows the whole apparatus to be rotated smoothly.

If the earth were moving through an aether at the same velocity as it orbits the sun (30 km/sec) then Michelson and Morley calculated that a rotation of the apparatus should cause a shift in the fringe pattern.

The basis of this calculation is given below.

## A Michelson Interferometer

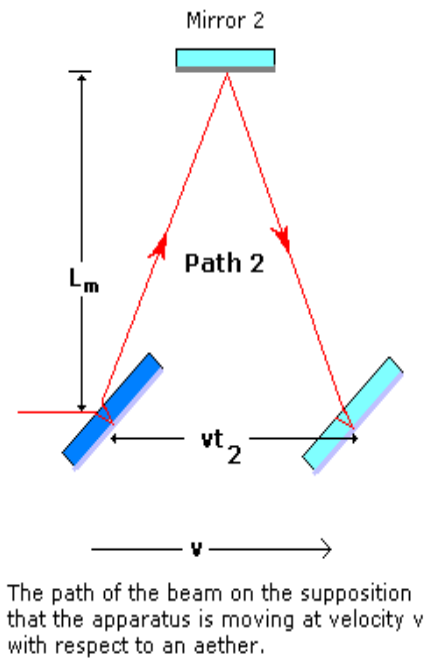
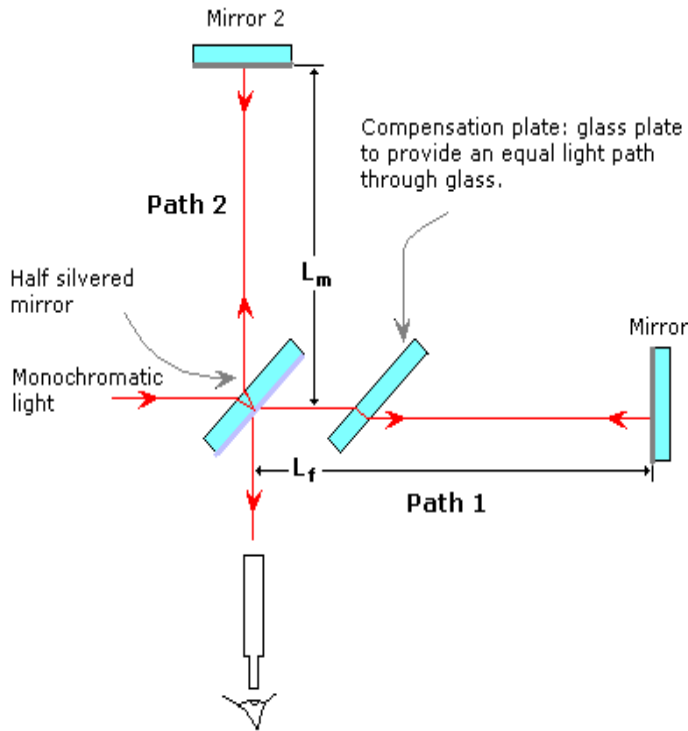

Consider the time taken  $t_1$  for light to travel along Path 1 in the illustration:

$$t_1 = \frac{L_f}{c - v} + \frac{L_f}{c + v}$$

Rearranging terms:

$$\frac{L_f}{c - v} + \frac{L_f}{c + v} = \frac{2L_f c}{c^2 - v^2}$$

further rearranging:

$$\frac{2L_f c}{c^2 - v^2} = \frac{2L_f}{c} \frac{1}{1 - v^2/c^2}$$

hence:

$$t_1 = \frac{2L_f}{c} \frac{1}{1 - v^2/c^2}$$

Considering Path 2, the light traces out two right angled triangles so:

$$ct_2 = 2\sqrt{L_m^2 + (vt_2/2)^2}$$

Rearranging:

$$t_2 = \frac{2L_m}{\sqrt{c^2 - v^2}}$$

So:

$$t_2 = \frac{2L_m}{c} \frac{1}{\sqrt{1 - v^2/c^2}}$$

It is now easy to calculate the difference ( $\Delta t$  between the times spent by the light in Path 1 and Path 2:

$$\Delta t = \frac{2}{c} \left( \frac{L_m}{\sqrt{1 - v^2/c^2}} - \frac{L_f}{1 - v^2/c^2} \right)$$

If the apparatus is rotated by 90 degrees the new time difference is:

$$\Delta t' = \frac{2}{c} \left( \frac{L_m}{1 - v^2/c^2} - \frac{L_f}{\sqrt{1 - v^2/c^2}} \right)$$

The interference fringes due to the time difference between the paths will be different after rotation if  $\Delta t$  and  $\Delta t'$  are different.

$$\Delta t' - \Delta t = \frac{2}{c} \left( \frac{L_m + L_f}{1 - v^2/c^2} - \frac{L_f + L_m}{\sqrt{1 - v^2/c^2}} \right)$$

This difference between the two times can be calculated if the binomial expansions of  $\frac{1}{1 - v^2/c^2}$  and

$\frac{1}{\sqrt{1 - v^2/c^2}}$  are used:

$$\frac{1}{1 - v^2/c^2} = 1 + \frac{v^2}{c^2} + \left(\frac{v^2}{c^2}\right)^2 + \dots$$

$$\frac{1}{\sqrt{1 - v^2/c^2}} = 1 + \frac{1}{2} \frac{v^2}{c^2} + \frac{3}{8} \left(\frac{v^2}{c^2}\right)^2 + \dots$$

So:

$$\Delta t' - \Delta t \approx \frac{L_f + L_m v^2}{c} \frac{v^2}{c^2}$$

If the period of one vibration of the light is  $T$  then the number of fringes ( $n$ ), that will move past the cross hairs of the telescope when the apparatus is rotated will be:

$$n = \frac{\Delta t' - \Delta t}{T}$$

Inserting the formula for  $\Delta t' - \Delta t$ :

$$n \approx \frac{L_f + L_m v^2}{cT} \frac{v^2}{c^2}$$

But  $cT$  for a light wave is the wavelength of the light ie:  $cT = \lambda$  so:

$$n \approx \frac{L_f + L_m v^2}{\lambda} \frac{v^2}{c^2}$$

If the wavelength of the light is  $5 \times 10^{-7}$  and the total path length is 20 metres then:

$$n = \left( \frac{20}{5 \times 10^{-7}} \right) 10^{-8}$$

So the fringes will shift by 0.4 fringes (ie: 40%) when the apparatus is rotated.

However, no fringe shift is observed. The null result of the Michelson-Morley experiment is nowadays explained in terms of the constancy of the speed of light. The assumption that the light would have a velocity of  $c - v$  and  $c + v$  depending on the direction relative to the hypothetical "aether wind" is false, the light always travels at  $c$  between two points in a vacuum and the speed of light is not affected by any "aether wind". This is because, in {special relativity} the Lorentz transforms induce a {length contraction}. Doing over the above calculations we obtain:

$$L_f = L_m \sqrt{1 - v^2/c^2}$$

(taking into consideration the length contraction)

It is now easy to recalculate the difference ( $\Delta t$  between the times spent by the light in Path 1 and Path 2:

$$\Delta t = \frac{2}{c} \left( \frac{L_m}{\sqrt{1 - v^2/c^2}} - \frac{L_f}{1 - v^2/c^2} \right) = 0 \quad \text{because } L_f = L_m \sqrt{1 - v^2/c^2}$$

If the apparatus is rotated by 90 degrees the new time difference is:

$$\Delta t' = \frac{2}{c} \left( \frac{L_m}{1 - v^2/c^2} - \frac{L_f}{\sqrt{1 - v^2/c^2}} \right) = 0$$

The interference fringes due to the time difference between the paths will be different after rotation if  $\Delta t$  and  $\Delta t'$  are different.

$$\Delta t' - \Delta t = \frac{2}{c} \left( \frac{L_m + L_f}{1 - v^2/c^2} - \frac{L_f + L_m}{\sqrt{1 - v^2/c^2}} \right) = 0$$

## Coherence length

The coherence length of light rays from a source that has wavelengths that differ by  $\Delta\lambda$  is:

$$x = \frac{\lambda^2}{2\pi\Delta\lambda}$$

If path lengths differ by more than this amount then interference fringes will not be observed. White light has a wide range of wavelengths and interferometers using white light must have paths that are equal to within a small fraction of a millimetre for interference to occur. This means that the ideal light source for a Michelson Interferometer should be monochromatic and the arms should be as near as possible equal in length.

The calculation of the coherence length is based on the fact that interference fringes become unclear when light rays are about 60 degrees (about 1 radian or one sixth of a wavelength ( $\approx 1/2\pi$ )) out of phase. This means that when two beams are:

$$\frac{\lambda}{2\pi}$$

metres out of step they will no longer give a well defined interference pattern. Suppose a light beam contains two wavelengths of light,  $\lambda$  and  $\lambda + \Delta\lambda$ , then in:

$$\frac{\lambda}{2\pi\Delta\lambda}$$

cycles they will be  $\frac{\lambda}{2\pi}$  out of phase.

The distance required for the two different wavelengths of light to be this much out of phase is the coherence length. Coherence length = number of cycles x length of each cycle so:

$$\text{coherence length} = \frac{\lambda^2}{2\pi\Delta\lambda}$$

## Lorentz-Fitzgerald Contraction Hypothesis

After the first Michelson-Morley experiments in 1881 there were several attempts to explain the null result. The most obvious point of attack is to propose that the Path that is parallel to the direction of motion is

contracted by  $\sqrt{1 - v^2/c^2}$  in which case  $\Delta t$  and  $\Delta t'$  would be identical and no fringe shift would occur. This possibility was proposed in 1892 by Fitzgerald. Lorentz produced an "electron theory of matter" that would account for such a contraction.

Students sometimes make the mistake of assuming that the Lorentz-Fitzgerald contraction is equivalent to the Lorentz transformations. However, in absence of any treatment of time dilation effect the Lorentz-Fitzgerald explanation would result in a fringe shift if the apparatus is moved between two different velocities. The rotation of the earth allows this effect to be tested as the earth orbits the sun. Kennedy and Thorndike (1932) performed the Michelson-Morley experiment with a highly sensitive apparatus that could detect any effect due to the rotation of the earth; they found no effect. They concluded that both time dilation and Lorentz-Fitzgerald Contraction take place, thus confirming relativity theory.

The fringe shifts due to velocity changes if only the Lorentz-Fitzgerald contraction applied would be:

$n = (v_1^2 - v_2^2)/c^2 \times (L_f - L_m)/\lambda$ . Notice how the sensitivity of the experiment is dependent on the difference in path length  $L_f - L_m$  and hence a long coherence length is required.

### External links

- [Interferometers Used in Aether Drift Experiments From 1881-1931](#)
- [Early Experiments](#)
- [Modern Michelson-Morley Experiment improves the best previous result by 2 orders of magnitude, from 2003](#)
- [The Michelson-Morley and Kennedy-Thorndike Experiments](#)

# Appendix 1

## Mathematics of the Lorentz Transformation Equations

Consider two observers  $O$  and  $O'$ , moving at velocity  $v$  relative to each other, who observe the same event such as a flash of light. How will the coordinates recorded by the two observers be interrelated?

These can be derived using linear algebra on the basis of the postulates of relativity and an extra homogeneity and isotropy assumption.

**The homogeneity and isotropy assumption:** space is uniform and homogenous in all directions. If this were not the case then when comparing lengths between coordinate systems the lengths would depend upon the position of the measurement. For instance, if  $x' = ax^2$  the distance between two points would depend upon position.

The linear equations relating coordinates in the primed and unprimed frames are:

$$\begin{aligned}x' &= a_{11}x + a_{12}y + a_{13}z + a_{14}t \\y' &= a_{21}x + a_{22}y + a_{23}z + a_{24}t \\z' &= a_{31}x + a_{32}y + a_{33}z + a_{34}t \\t' &= a_{41}x + a_{42}y + a_{43}z + a_{44}t\end{aligned}$$

There is no relative motion in the  $y$  or  $z$  directions so, according to the 'relativity' postulate:

$$\begin{aligned}z' &= z \\y' &= y\end{aligned}$$

Hence:

$$\begin{aligned}a_{22} &= 1 \text{ and } a_{21} = a_{23} = a_{24} = 0 \\a_{33} &= 1 \text{ and } a_{31} = a_{32} = a_{34} = 0\end{aligned}$$

So the following equations remain to be solved:

$$\begin{aligned}x' &= a_{11}x + a_{12}y + a_{13}z + a_{14}t \\t' &= a_{41}x + a_{42}y + a_{43}z + a_{44}t\end{aligned}$$

If space is isotropic (the same in all directions) then the motion of clocks should be independent of the  $y$  and  $z$  axes (otherwise clocks placed symmetrically around the  $x$ -axis would appear to disagree. Hence

$$a_{42} = a_{43} = 0$$

so:

$$t' = a_{41}x + a_{44}t$$

Events satisfying  $x' = 0$  must also satisfy  $x = vt$ . So:

$$0 = a_{11}vt + a_{12}y + a_{13}z + a_{14}t$$

and

$$-a_{11}vt = a_{12}y + a_{13}z + a_{14}t$$

Given that the equations are linear then  $a_{12}y + a_{13}z = 0$  and:

$$-a_{11}vt = a_{14}t$$

and

$$-a_{11}v = a_{14}$$

Therefore the correct transformation equation for  $x'$  is:

$$x' = a_{11}(x - vt)$$

The analysis to date gives the following equations:

$$x' = a_{11}(x - vt)$$

$$y' = y$$

$$z' = z$$

$$t' = a_{41}x + a_{44}t$$

Assuming that the speed of light is constant, the coordinates of a flash of light that expands as a sphere will satisfy the following equations in each coordinate system:

$$x^2 + y^2 + z^2 = c^2t^2$$

$$x'^2 + y'^2 + z'^2 = c^2t'^2$$

Substituting the coordinate transformation equations into the second equation gives:

$$a_{11}^2(x - vt)^2 + y^2 + z^2 = c^2(a_{41}x + a_{44}t)^2$$

rearranging:

$$(a_{11}^2 - c^2a_{41}^2)x^2 + y^2 + z^2 - 2(va_{11}^2 + c^2a_{41}a_{44})xt = (c^2a_{44}^2 - v^2a_{11}^2)t^2$$

We demand that this is equivalent with

$$x^2 + y^2 + z^2 = c^2t^2$$

So we get:



$$\begin{aligned}
c^2 a_{44}^2 - v^2 a_{11}^2 &= c^2 \\
a_{11}^2 - c^2 a_{41}^2 &= 1 \\
v a_{11}^2 + c^2 a_{41} a_{44} &= 0
\end{aligned}$$

Solving these 3 simultaneous equations gives:

$$\begin{aligned}
a_{44} &= \frac{1}{\sqrt{(1 - v^2/c^2)}} \\
a_{11} &= \frac{1}{\sqrt{(1 - v^2/c^2)}} \\
a_{41} &= -\frac{v/c^2}{\sqrt{(1 - v^2/c^2)}}
\end{aligned}$$

Substituting these values into:

$$\begin{aligned}
x' &= a_{11}(x - vt) \\
y' &= y \\
z' &= z \\
t' &= a_{41}x + a_{44}t
\end{aligned}$$

gives:

$$\begin{aligned}
x' &= \frac{x - vt}{\sqrt{(1 - v^2/c^2)}} \\
y' &= y \\
z' &= z \\
t' &= \frac{t - (v/c^2)x}{\sqrt{(1 - v^2/c^2)}}
\end{aligned}$$

The inverse transformation is:

$$\begin{aligned}
x &= \frac{x' + vt'}{\sqrt{(1 - v^2/c^2)}} \\
y &= y' \\
z &= z'
\end{aligned}$$

$$t = \frac{t' + (v/c^2)x'}{\sqrt{1 - v^2/c^2}}$$

## Alphabetical Index

Addition of velocities.....	42
aether.....	53
aether drag hypothesis.....	53
aether drift.....	62
aether wind.....	58
Andromeda paradox.....	28
Arago, François.....	55
Aristotle.....	10
ballistic theory.....	62
Brillet-Hall experiment.....	62
causality.....	23
Coherence length.....	67
coordinate length.....	18
coordinate system.....	10
corpuscular theory of light.....	53
De Broglie waves.....	32
drift velocity.....	32
Einstein, Albert.....	6
electric field.....	31
Emission theory.....	62
Energy.....	50
energy, rest.....	51
energy, total.....	51
entrainment.....	61
event.....	10
First postulate: the principle of relativity.....	13
Fitzgerald, George.....	5
Fizeau experiment.....	56
Force.....	50
four-dimensional universe.....	16
Fresnel.....	55
Fresnel drag coefficient.....	55
fringe shift.....	66
Galilean Relativity.....	10p.
Galilean transformation.....	11
Galileo.....	10
Galileo's Law of Inertia.....	10
gamma factor.....	49
Hils and Hal.....	62
Huygen's principle.....	53
Huygens, Christiaan.....	53
imaginary unit.....	16
inertial reference frame.....	10
interferometer.....	62
invariance.....	14
invariant mass.....	49
James Clerk Maxwell.....	5

Kennedy-Thorndike experiment.....	63
kinetic energy.....	45, 52
Larmor, Joseph.....	5
law of conservation of momentum.....	45
length contraction.....	18, 28
Light propagation.....	53
lightcone.....	22
Lorentz factor.....	51
Lorentz gamma factor.....	49
Lorentz transformation.....	24
Lorentz Transformation Equations.....	69
Lorentz-Fitzgerald Contraction Hypothesis.....	68
Lorentz, Hendrik.....	5
magnetic field.....	31
maximum velocity.....	23
Maxwell, James Clerk.....	5
metric tensor.....	16
Michelson interferometer.....	63
Michelson-Morley experiment.....	57
Mille, Dayton.....	60
Minkowski, Hermann.....	6, 14
momentum.....	45
momentum conservation.....	47
momentum, relativistic.....	49
Newton's First Law of Motion.....	10
Newtonian conservation of momentum.....	46
Newtonian Relativity.....	11
Noether, Emmy.....	14
null geodesic.....	23
Phase, relativistic.....	19
Poincaré, Henri.....	7
Pole-barn paradox.....	40
postulates of special relativity.....	13
preferred reference frame.....	13
present moment.....	26
principle of relativity.....	10
proper time.....	18
Pythagoras' theorem.....	14
reference frame.....	10
reference frame, inertial.....	10
refractive index.....	55
relativistic 3 force.....	50
Relativistic Dynamics.....	45
relativistic mass.....	48
relativistic momentum.....	49
Relativistic phase.....	19
relativistic velocity addition theorem.....	43
Relativity of Simultaneity.....	19
rest energy.....	51
rest mass.....	48

Rietdijk-Putnam-Penrose argument.....	27
Second postulate: invariance of the speed of light.....	13
Simultaneity.....	19
space separated.....	23
space-time diagrams.....	20
space-time interval.....	16
spacetime.....	14
Spacetime.....	21
speed of light.....	23
Speed of light.....	16
stellar aberration.....	54
time dilation.....	18, 33
time gap.....	28, 34
time separated.....	23
time travel.....	33
total energy.....	51
Trimmer experiment.....	62
Trouton-Noble experiment .....	63
twin paradox.....	34
unification.....	31
velocity addition theorem.....	12, 43
wave theory of light.....	53
Wikibook.....	9
worldtube.....	29
Young's slits.....	53