

Scientific American.

THE ADVOCATE OF INDUSTRY, AND JOURNAL OF SCIENTIFIC, MECHANICAL AND OTHER IMPROVEMENTS.

VOLUME 6.]

NEW-YORK, JUNE 28, 1851.

[NUMBER 41.

THE
Scientific American,
CIRCULATION 16,000.

PUBLISHED WEEKLY

At 128 Fulton, street, N. Y., (Sun Building,) and
13 Court street, Boston, Mass.

BY MUNN & COMPANY,

The Principal Office being at New York.

A. T. Hottelkiss, Boston.
Dexter & Bro., New York City.
Weld & Co., New Orleans.
Stoker & Bro., Philadelphia.
R. E. Edwards & Co., Cincinnati, O.
Jno. Thomson.
Edwards & Ringgold, Louisville, Ky.
Cooke & LeCount, San Francisco, Cal.
Courtenay & Wienges, Charleston, S. C.
John Carruthers, Savannah Ga.
Barlow, Payne & Parken, London.
M. M. Gardisall & Co. Paris.

Responsible Agents may also be found in all the principal cities and towns in the United States.

TERMS---\$2 a year---\$1 in advance and the remainder in 6 months.

Rail-Road News.

Profits of Railroads.

From a list in the Boston Advertiser of thirteen Railroads and their branches, in Massachusetts, with 238 miles of double track, 375½ of single, costing in the whole \$38,812,689, it appears that more than half the companies paid dividends in 1850, from the net profits of the year, 8 per cent.; and the whole exceed 7 per cent.; each having retained a greater or less reserve; while, in England, the past year, no company paid more than 5 per cent, with the exception of four, which paid respectively £7, 14s per cent., 6 per cent., 5½ per cent. and 5¼ per cent. Six other companies paid 3 per cent.; several from 1 to 3; and a number nothing. The Great Western with a capital of nearly £14,000,000, 264 miles long, paid 4 per cent.; the London and South-Western, capital £8,390,000, 4 per cent.; the South-Eastern and Greenwich, capital £9,460,000, 3½ per cent.; the Midland and Bristol, 496 miles, capital £15,450,000, 2½ per cent.; the Lancashire and Yorkshire, 260 miles, capital £11,488,000, 2 per cent.

Tunnel through the Green Mountains.

The friends of the Troy and Greenfield Railroad appear not to be discouraged by the failure of their attempt to get the State credit for tunnelling Hoosac Mountain, but are proceeding as rapidly as their means will permit with the execution of the work. They intend to commence the work of tunnelling on the east end of the mountain, so as to demonstrate to the next Legislature if possible, the feasibility of the project. A writer in the North Adams Transcript, speaking of the road, says:—

"The work is rapidly progressing from Troy to Hoosac; and the heaviest of the grading is nearly finished from Adams to Pownal. If all the stockholders meet their assessments promptly, so that there be no delay on that account, the cars will run from Adams to Troy by the 1st of January, 1852."

Coal Fields of Pennsylvania.

Mr. McGinnes, an able mining engineer, of Pottsville, Pa., has asserted and advanced the theory long ago, that under the red ash coal seams, the large white ash coal seams would be found at workable depths. This theory has been demonstrated lately by boring. The Schuylkill coal basin is now held to be three times more valuable than it was a short time ago.

A False Island.

An island has been placed on the charts in lat. 33° 19' N., lon. 42° 39' W., which, Capt. W. G. Currier says, is not to be found. He has sailed over the island on the nautical charts twice. No island was ever seen there.

ISON'S IMPROVEMENTS IN MACHINERY FOR MAKING SPIKES AND NAILS.

Fig. 1.

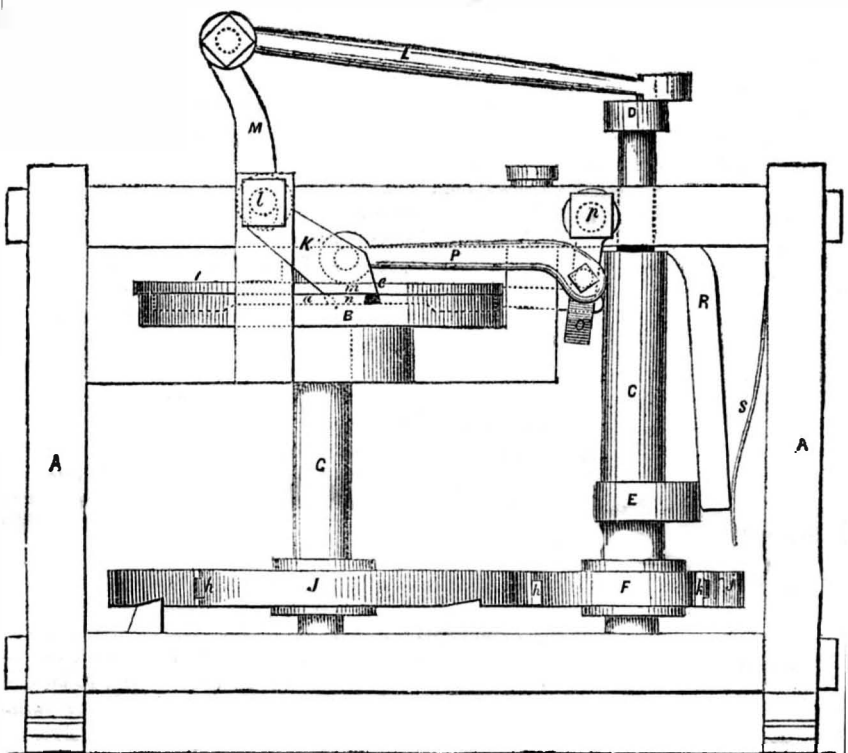

The improvements in machinery which the accompanying engravings illustrate, is the invention of Mr. Mark M. Ison, of Etowah, Cass Co., Ga., who has taken measures to secure a patent for the same. Owing to the number of cuts required to illustrate this machine, two of the figures, with the description, are contained on the Fourth Page.

Fig. 1 is an elevation of that side of the machine where the iron is cut off and pointed. Fig. 2 is an elevation of the opposite side when the heading is performed and the spike or nail delivered from the machine. Fig. 3 is a plan view, and fig. 4 is a plan of the table and carrier. The same letters refer to like parts.

The invention consists in a curved horizontal table having a hollow space within it, in which works a revolving cam or carrier, hung on a shaft concentric to the table. The iron plate from which the spikes or nails are to be made is fed along the upper surface of the table, is cut off in strips of suitable size across the edge of an opening in the top of the table, by a vibratory shear arm working above, and the pointing is performed between the said shear arm and the table. The cam mentioned, which revolves and becomes stationary at regular intervals, is then made to carry the spike round within the hollow space in the table, and allow it to stop under a holding die, which moves up and down in a line at right

Fig. 2.

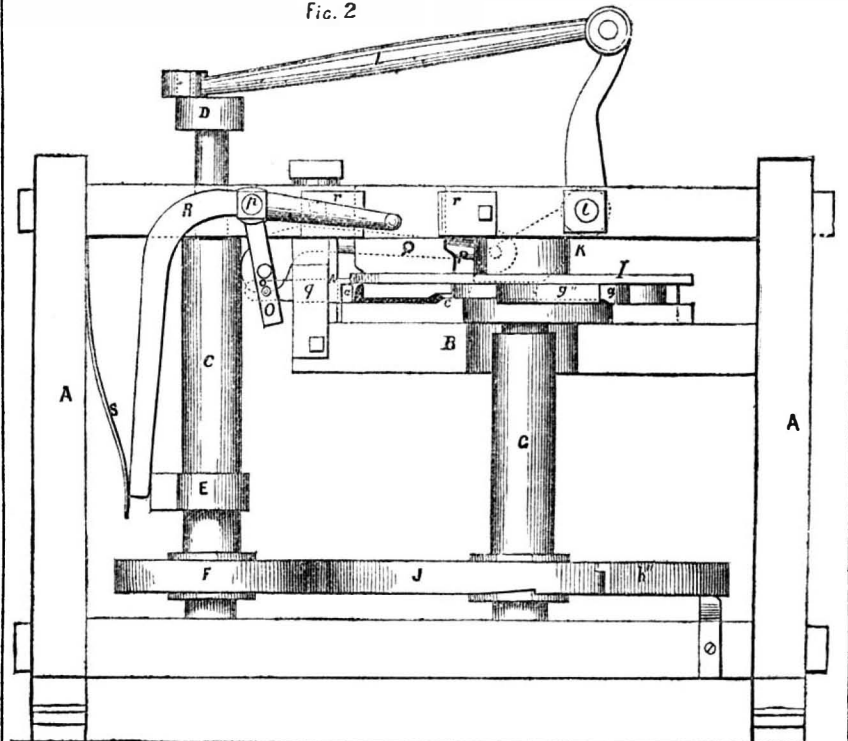

angles to the face of the table and the motion of the carrier. By a suitable movement, this die is then brought down upon it to hold it while a heading tool moving nearly in a line with the spike is made to act upon and form

the head of the spike or nail. A A is the framing; B is the stationary table consisting of a plate of metal of the form of a segment of a circle, a little larger than a semi-circle; it has a projecting rim standing up from its face

nearly all along the circular part of its face, and upon this rim a plate, I, is secured, leaving a space between it, and the lower part of the table. At a distance from the inside of the rim, equal to the intended length of the spike before heading; there is a slightly raised boss, c, presenting the form of a segment of the frustum of a cone, the inclination of its periphery being the reverse of the inclination or bevel required for the point of the spike, is intended to form one side of the said point. Through the plate, I, there are two openings, one, b, of considerable size, shown in fig. 3, and another, d, which is merely a slot through which the holding die passes. The edge, e, of the opening, b, must be steeled, as it is intended to form one cutting edge of the shears which cut off the spike. C is the main shaft which is hung in suitable bearings in a vertical position; it carries at its upper end a crank, D, whose wrist, f, has a very short throw, for operating the vibrating shear arm; it also carries a cam, E, for operating the holding down die, and a friction wheel, F. G is a shaft hung in bearings parallel to C, it passes through the centre of the table, B, carrying the three armed cam or carrier, H, the three arms, g g' g'', of which fit in the space between the bottom of the table, B, and the upper plate, I; the front faces of the arms are nearly radial. The shaft, G, also carries a friction wheel, J, whose periphery is provided at three equi-distant points with small projections or teeth, h h' h'', at the back of each of which the periphery is slightly recessed. One part of the periphery of the wheel, F, corresponding in length with each space on the wheel, J, between two of its teeth, is more prominent than the other part which is recessed from i to j, in fig. 3, but has a small tooth, k, projecting near to j; the prominent part of the periphery of the wheel, F, when in contact with the periphery of the wheel, J, will, by the revolution of the main shaft, C, cause it (the wheel) to move on its axis, by reason of the friction of contact, but the less prominent or recessed part passes without moving it; the starting of the wheel, J, being accomplished by the tooth, k, coming in contact with h h' or h''. K is the vibrating shear arm attached to a deep socket working on a centre pin, l, secured in the frame; its edge, m, or the whole arm is steel, forming, with the edge, e, a pair of shears; the under face of the arm is provided with a bevelled projection, n, at one end, which comes immediately over the periphery of the conical surface, c, and when the shear arm is brought down, presses or forms the point of the spike after cutting it off. The shear arm receives the necessary motion by means of a pitman, L, connected to the wrist, f, of the crank, D, and to an arm or lever, M, on its own socket. N is the header, which is attached by a pin, o, to a lever frame, O, hung on a stationary pin or centre, p, secured in the frame; it works through a guide, q, in the frame, and receives the necessary motion at the proper time through a rod, P, connecting the lever frame, O, with the vibrating shear arm, K. Q is the holding down die, which is of suitable form on its under side to hold the spike secure upon the table while the header is made to act upon it; it slides in guides, r, and is brought down upon the spike at a suitable time, and held down by means of a bent lever, R, having its fulcrum on the pin, p; one end of this lever is inserted in a suitable recess in the die, and the other end bears upon the cam, E, being held against it by a spring, S.

The operation of the machine is as follows:—Rotary motion is given to the shaft, C, by any convenient means, in the direction of the

[Continued on the Fourth Page.]

Miscellaneous.

[Special Correspondence of the Scientific American.]

LONDON, June 5th 1851.

The price for admission to the great Exhibition being now reduced to one shilling sterling (22 cents) the number of visitors has greatly increased. No less than fifty thousand five hundred visited it yesterday, yet for all this there was no crowd.

Among the American inventions are some of the patent chairs of Mr. Warren, of Troy, N. Y., engravings of which appeared in the Scientific American. The London Patent Journal publishes a very neat engraving of the chair, and speaks in very flattering terms—and justly so—of its merits. An engraving of Heald's American Harness Machine has appeared in the columns of the London Illustrated News, but it is a miserable representation.

The Morning Chronicle speaks well of the American show of raw materials. It says:—"Under the general classification of raw material, the contributors from the States exhibit many very excellent specimens. There are among these a large variety of articles, such as indian corn, ground, hulled, and in the ear; rye, oats, barley, wheat, tobacco, minerals, chemicals, woods, brooms, beef, pork, lard, hams, and almost everything else identified with the productions of that country. Next in order are to be seen daguerreotypes, paintings, herbaria, and prints, with some samples of stained glass suspended from the galleries, and cottons, carpetings, wrought quills, calicoes and needle work, tastefully displayed around. Considering the distance from which these had to be conveyed, not only across 3,000 miles of ocean, but often from little short of that distance inland—and considering, too, that it is not in her manufactures that America makes her chief impression upon the world—we regard this portion of her exhibition with great interest."

I quote this to show our countrymen that those things which have been sent here are appreciated.

It is the duty of our commissioner to make out a catalogue of prices for the American contributions. Mr. Riddle has met with unexpected difficulties in doing this. This catalogue of prices is important to jurors, who are directed to take the cost of production into view as one element on which to base their decision. Every contributor should have sent the price along with his contribution. The following is the list of American jurors:

Horace Greeley, Chair'n,	Class 22, New York.
Ashbel Smith,	do. 3, Texas.
Judge Duncan,	do. 4, Virginia.
Robert McCarthy,	do. 5, New York.
O. Macdaniel,	do. 5, N. Jersey.
Samuel Webber,	do. 6, Mass.
Dr. J. V. C. Smith,	do. 7, do.
Asa Whitney,	do. 8, New York.
B. P. Johnson,	do. 9, do.
C. M. Lampson,	do. 9, Mass.
E. R. Leslie, R. A.,	do. 10, do.
Dr. Geo. B. Loring,	do. 10, do.
Dr. Chadbourne,	do. 10, N. H.
Col. B. E. Coxe,	do. 11, Alabama.
Chas. Kingsbury,	do. 12, Conn.
John H. Swift,	do. 15, New York.
J. S. Cunningham,	do. 16, Virginia.
Henry Stevens,	do. 17, Penn.
Elliot Cresson,	do. 20, do.
L. C. Duncan,	do. 24, Louisiana.
Rev. Gorham D. Abbott,	do. 28, New York.
B. R. Smith,	do. 1, Virginia.

You may have seen a letter in the London Times from an American, explaining why there were not more exhibitors from the United States. The views presented were those which appeared in the editorial columns of the Scientific American. The letter in question has done good, and I should like to see it published by you.

(We hear present the important parts of said letter.)

The fact is, that in no one branch is the United States fairly or adequately represented; and in this I shall be fully borne out by all Englishmen who have visited America.

The North, or New England States, are not

represented, either as to the extent, the progress, or the variety of their manufactures. The middle States, that have long been famous for the invention and construction of some of the finest machinery in the world—in which branch they are second to none—have here but three or four machines, which, excellent as they are, give but the faintest idea of the gigantic progress of the country in this particular. The Southern States, which are principally agricultural, are most certainly not represented. As an illustration of the many kinds of cotton cultivated, we find here but samples of seven, while the different varieties of sugar in the State of Louisiana, are represented by one specimen from a single plantation.

Now, to the causes. First, the want of sufficient information through the length and breadth of the States in reference to the character and extent of the exhibition. This at present lies at the door of the Central Committee at Washington. Secondly, Congress has unfortunately appropriated no fund, as in other countries, to assist exhibitors. And this has operated to strengthen the third cause—the remoteness of the scene of action, an obstacle increased by the great extent of the country, which rendered the internal transmission of our contributions expensive and inconvenient, and even, in some instances impracticable—and which, added to the distance itself, made this a very onerous part of our outlay. The time for preparation, too, was short, considering the nature of the enterprise and the distance of the country.

The enumeration of these causes, offered in the spirit of candor and in a firm conviction of their literal truth, will, it is believed, mainly account for the incompleteness of the American department of the exhibition.

EXCELSIOR.

Custom House Scrutiny in Liverpool.

Persons going to the World's Fair should be careful about taking tobacco and books. An American editor who went to see the sights states that the Custom House officials in Liverpool are a prying set of fellows, and are down especially strong on any over-allowance of tobacco which a passenger may chance to have, and for American reprints of English publications there is no mercy but the flames. All these reprints, and every passenger's trunk contained several of them—were not allowed to pass on any condition, but as fast as they were found, were thrown in a pile for the purpose of burning. The search for the Virginia weed was most penetrating, and all who had more than half a pound were compelled to pay duty at the rate of nine shillings sterling per pound. The editor's stock of cigars weighed a pound and a half, on which he paid a duty of \$3.75. On American books, of which he had eight pounds, he paid a duty of four and a half pence sterling. The bound volumes of the several newspapers in the State, designed for the Worlds Fair, after much difficulty were allowed to pass on the payment of a duty of twenty dollars. This is enforcing the revenue laws strictly.

[The above is from the Philadelphia Ledger and to those who are still designing to go to the World's Fair, we say, pay strict attention to the lesson therein taught. Every word is true. The officials of the Liverpool Custom House are rude and ungentlemanly; indeed, the whole of the officials under the British Government are generally gruff and uncivil. The officers under the American Government are gentlemanly and civil—the contrast is very great. What we have said has not been uttered for any other purpose than to tell the truth, and, we hope for a good effect. It would be much to the credit of the ministers of the British Government, if they enjoined the same civility upon their Custom House officials as is enjoined by the magistrates of London upon their police.]

The everlasting perseverance of the Yankee is admirably illustrated in a case that lately occurred at Lynn, away down east. A cute chap indentured himself to a boot-maker for two weeks, to learn to fit boots. At the end of three days he bought out his time, and set up for himself.

Electro-Magnetism as a Moving Power.

In last week's number of the Scientific American, Prof. Page, of Washington, criticises the views expressed on page 285. He says: "The writer takes unnecessary pains to show that electro-magnetism is far inferior to steam as a motive power—a fact never doubted by any one conversant with the subject."

Here he admits the conclusions of the writer he speaks of, to be correct and sound, and had he said no more he would have administered a rebuke to him for his "unnecessary pains," but his long article is an evidence that there was and still is a necessity for saying something about the comparative merits of steam and magnetism as motive powers. Mr. Page says he "has never met with an investigator of electro-magnetism who did not evince an acquaintance with steam power;" this may be true, but others cannot say as much, and he has a very singular way of estimating the power of locomotives himself, as set forth on page 277 of the Scientific American, and also what is said about the strong horse in Washington. And, as it respects the economy of Electro-Magnetic Power, he has also peculiar ideas. He says:—"The truth is, that the cost of electro-magnetic power, or any other power, is circumstantial, and the attempt to predicate the whole economy of magnetic power upon the cost of coal and cost of zinc, and the fact that coal is found native and zinc not, is in effect, to make nature's laws and operations amenable to market prices and other contingencies."

That's it exactly, Sir, just as all engineers (the best judges) in the market of the world understand it. The whole economy of any motive power is amenable to market prices, and so are nature's laws and operations, not forgetting the contingencies, when connected with engineering and manufacturing operations. If Mr. Page leaves Electro-Magnetic Power out of the market—beyond the claims of market prices, then there is an end to the whole matter, and it is to be regretted that Congress expended so much money on his experiments. But then the whole article referred to is written in a tone to present electro-magnetism, as a prime motor, in the most favorable light as compared with steam, he therefore deprecates the claims of steam engineering in order to elevate electro-magnetic engineering. The very facts, however, which he brings forward, destroy his own barricades. He says—

"The proper appreciation of magnetic power is to be had by comparing it with steam in an equal stage of its development, when it will be seen that the magnetic power rather carries the palm. Steam power has not yet reached its climax, but it seems as if it were approaching its culmination, as its march seems to be comparatively slow; while magnetic power, evidently in its inception, is progressing rapidly."

Let us test the two powers by his own touchstone:—In 1804, he says, the first steam locomotive made 5 miles an hour, and drew 15 tons on a level plane, and after 25 years of experience (1829) Mr. Stephenson constructed the "Rocket," which drew 17 tons at the rate of 15 miles an hour. Well, now, let us see what progress the Electro-Magnetic Engine has made. He says—

"As to Davidson's engine, it was fully tested by myself on a large scale in Boston, in 1837, and it was invented and tried in Baltimore by Dr. Edmonson, in 1834." Now here is 17 years' experience, and how much has he improved it? He tells his own story thus: "With my magnetic locomotive just as it is, I would willingly have entered the list with the Rocket in point of power, speed, and expense of working. I feel confident, however, that the magnetic locomotive is capable of carrying two loaded passenger cars to Baltimore at the rate of 20 miles an hour, as soon as some of the very great and obvious defects are remedied."

Here, then, after 17 years' experience, he has caught up with the "Rocket" of 1829, and will be enabled to go to Baltimore at the rate of 20 miles per hour, after some very great defects are remedied. Now, if the steam engine progresses so slowly as he states, and the mag-

netic is progressing so fast, how is it that he states in another place that "the expense of a horse-power, in the Cornish steam engines, has been reduced, within a few years, from 10d to 2d per diem?" And how has the locomotive progressed since 1829? Why, some can run at the rate of 60 miles per hour; and we know of one locomotive which, last year, drew 40 cars loaded with 200 tons of coal the distance of 58 miles, and consumed only one ton and a half of anthracite coal. Has electro-magnetism as a prime mover, advanced as rapidly as this? Certainly not: it is not yet up to the "Rocket." Had he entered the lists with the "Rocket" he would certainly have been defeated, for it did not break down on its first trip, all went on snug, safe, and sure; the little engine of 4 tons 5 cwt. drew three times its own weight for 70 miles, at the average rate of 15 miles per hour. Without a load it went at the rate of 30 miles per hour. There was another engine tried along with the "Rocket," the merits of which should be mentioned, viz., the "Novelty;" this locomotive did not weigh quite 2 tons, yet it drew 11 tons 5 cwt. the distance of 21 miles in one hour—when some of its tubes gave way and the competition was given up. The Electro Magnetic locomotive is immeasurably behind the "Novelty" yet. And here let it be understood that the improvements which were made in the locomotive in the 25 years spoken of, were all ready made to the electro-magnetic engine, and have been appropriated without as much as saying "I thank ye."

The first locomotive of Trevethick, patented in 1804, had only a single cylinder, and ran on a tram road with plain wheels. The cog wheels, the rack rail, the leg locomotive, the plain wheels, and the tram rails, had all to be surmounted by the steam engineers; the flange wheels and heavy rails—those great improvements in steam engineering,—were all ready for the magnetic engineers when they commenced operations in 1834, and yet, with their 17 years' improvements, there is not a solitary electro magnetic locomotive in practical operation throughout the wide expanse of Christendom; in fact, Prof. Page himself has only arrived at the point of doubtful vacillation in choosing between a reciprocating and rotary electro-magnetic locomotive.

Respecting the remarks which he makes about Liebig, he has neither made just comparisons, nor presented Liebig's views correctly. Electricity develops both heat and attractive force—chemical and mechanical effects—the one is as much electricity as the other is, but different means are employed to develop them, and the one is just as powerful as the other, in performing its functions; the means to develop both, however, may not be equally perfect. The experiment at Baltimore proves nothing; it is only 30 years since electro-magnetic power was discovered; before that chemical electricity had resolved the hard diamond into gas in a much shorter space of time than mechanical electricity could now grind it into the same state, but it would be erroneous to make a comparison of the two powers. Prof. Page knows full well the difference between electrical intensity and quantity. No engineer, comparatively, estimates the power of his engine by the heat of the steam, but the quantity of it. In 1843 the eminent Liebig said, "the employment of the galvanic pile, as a motory power, must, like every other contrivance, depend upon the question of its relative economy; some time hence it may so far succeed as to be adopted in certain favorable localities." Could anything be less absurd than this? Could anything be more reasonable? Well, old German Philosopher, nearly eight years has passed away since, and not one of the improvers of electro-magnetic engines has been so fortunate as to get it adopted in the most favored or unfavored locality in the world, and to all appearances it will be a long time before they will

A great number of practical facts respecting the superior economy of steam power might be adduced but there is no necessity for doing so at present. The difference between the steam and magnetic locomotive, at present, is that the former is cheap, practical, and in universal use; the latter is not yet practical. *

Hibbard's Patent Process of Tanning.

The following specification is that of the patent of Herman Hibbard, of Henrietta, N. Y., for tanning leather, granted Oct. 16, 1849, transferred to Wm. Reid, of Rochester N. Y., and re-issued to him on the 11th of last Feb., 1851. As the tanning interests of this country are very great, and always increasing in importance, and as we have had a great many inquiries about this new system, named "Hibbard's Tanning Process," we presume, that in publishing this document we are doing the state some service. The specification is a true and official copy derived from the patent office by paying for the same.

To all whom it may concern:—Be it known that I, William W. Reid, of the city of Rochester, in the county of Monroe, and State of New York, assignee of Letters Patent of the United States, granted to Herman Hibbard, of the town of Henrietta, in the county and State aforesaid, for certain improvements in "Tanning by Tannin and acids," which Letters Patent, bearing date the 16th day of October, 1849, were assigned to me on the 23rd day of October, of the same year, by deed, which deed was duly recorded on the 24th of Nov., year aforesaid, believing that said Letters Patent are inoperative, and invalid by reason of a defective specification, have surrendered the same, and according to the requirements of the Acts of Congress in such case made and provided, have applied for a re-issue of Letters Patent, for the same improvements under the specification of the words following, viz.: the invention and discovery of Herman Hibbard, consist in new and useful improvements in the preparing of hides and skins for tanning, and in the art or mode of tanning the same, with or without the hair or wool upon them, thereby making leather suitable for the various purposes to which hides and skins thus tanned may be applied.

First, the nature of his invention, so far as relates to the preparation of hides and skins for tanning, consists in the use of a composition of lime, wood-ashes or potash, and salt, for the purpose of removing hair or wool, and also for the process of "Liming," so called, instead of using lime alone as in the old method.

Lime and ashes or potash, and even salt in weak solution, have been used separately for the purpose of removing hair and wool, and also for the process of "Liming" that is, for removing grease, mucans, and other impurities from hides and skins, but not as above combined.

It requires several days and sometimes weeks to effect these several objects, by the use of lime alone. Moreover, lime being nearly insoluble, the hides become impregnated therewith, so that bates and drenches and much labor are required to remove it, before the hides are in a suitable condition to receive the tannin, in consequence of which, their muscular fibre and texture are materially injured. But potash being very soluble, is easily washed or worked out by water alone; besides, it has a greater affinity for fat or oil, and makes a soluble soap, which is also easily worked out; but lime makes an insoluble soap, which is removed with more difficulty; potash being soluble, penetrates and softens the hide more speedily, and thus enables the lime itself to act sooner than it could alone. But fresh quick lime loosens hair sooner than potash. Thus the two conjoined, subserve a better purpose than either singly.

Salt, in solution, also aids in softening dry or hard hides. It protects the substance of the hide from the too caustic action of the alkalies—loosens dirt, grease, &c., and thereby purifies the skin. It might be omitted in treating salted hides unless soaked too long in water. But in all cases it preserves the substance and weight of the hides, while undergoing the liming process.

Second, the nature of Hibbard's invention, so far as it relates to the process of tanning consists in the use of a composition of salt, sulphuric acid, and sumac, oak, hemlock bark, or any other tannin used for tanning.

The salt, sulphuric acid, and tannin being mixed together in water, in certain proportions hereafter mentioned, a portion of the salt is decomposed by the sulphuric acid, forming

sulphate of soda and setting muriatic acid free, which (the muriatic acid) being absorbed by the water acts directly and rapidly on whatever of the alkalies may yet remain in the skins, dissolving and removing them, while it acts with equal rapidity on the hide itself "raising it," or opening its pores, prepares it to receive the tannin, which, being present also in the mixture, immediately unites with the gelatine of the hide, forming leather more expeditiously than by the old method.

To enable others skilled in the art of tanning to use this method, let them observe the following:

For unhairing and liming, so called, and for pulling wool, prepare and use the following composition, which we denominate—

Composition No. 1.—Good wood ashes, 1 bushel (or potash about 5 pounds); fresh slacked lime 4 quarts; salt about 3 quarts; water about 100 gallons.

These ingredients may be mixed together and the hides be put into the mixture, for unhairing and liming. But for pulling wool, take lime and ashes equal parts, and salt 1 quart, to 1 bushel of the mixture and mix with water sufficient to make a thin paste, which is to be applied to the flesh sides of the skins in the usual way, and kept at a temperature of 60° to 65° F.

Or a better method may be to leach the ashes, or, when potash is used, to dissolve it in the water. To the clear lye add the lime and salt, and use this mixture for unhairing and liming. But for pulling wool mix 1 bushel of lime and 1 quart of salt with good strong lye, making a thin paste, which apply to the flesh sides of the skins, as already described.

A little practice will enable the operator to judge of the proper strength of composition No. 1. It should have a slippery feel and quite a sharp alkaline taste. It is readily made stronger by addition of more materials, or weaker by adding water.

The above quantities and proportions serve as a general guide. The lime and ashes or potash may be used in various proportions, but it is desirable that as little lime as possible to produce the desired effect, should be used, because of its insolubility and of its insinuating itself into the substance of the hide. The hides or skins having been properly soaked, softened, and broken are to be put into composition No. 1, in a vat or vats, and handled in the usual way. The temperature may be kept at 50° to 60° F.

As soon as the hair will come freely, they must be taken out and put into clean soft warm water, and soaked several hours, then thoroughly worked, flesh and grain, on the beam. Then put back into the water, soaked again and worked again, till they are sufficiently reduced. They are then ready for the tanning process. As a general thing, bates and drenches will not be required, because the potash being soluble, and the little lime used, are easily washed out with water, and because composition No. 2, about to be described, used in the tanning, accomplishes the identical objects to be obtained by bating and drenching. If any prefer they may prepare their hides and skins after the old method. They can be tanned just as well by composition No. 2, but skins and hides prepared by the foregoing method will make heavier and stronger leather, than when prepared by the old process of tanning and bating.

For tanning, make and use the following which we denominate

Composition No. 2.—Take sumac, oak bark, quercitron, or any other tanning material, either singly or combined; leach and make a strong infusion or ooze. To every 100 gals. of ooze add salt, 20 lbs.; sulphuric acid, 2 pints.

These quantities serve as a general rule. A little experience will enable a workman to determine by the color and taste, as to the requisite proportions and quantities and strength of the composition without weighing or measuring.

The salt should always be in excess over the acid. If it is considerably more so, no harm can accrue, but if the acid should be in excess, injury might be done. There should be sulphuric acid enough to decompose enough of the salt to liberate an equivalent of muriatic

acid, of which there should be as much as is sufficient to give the hides a uniform color, and cause them to swell or puff up slightly.

The muriatic acid thus generated by the decomposition of the salt, by means of the sulphuric acid, attacks the alkalies that may remain in the hides, dissolves or converts them into soluble muriates of lime or potash, and thus acts as a bate and drench on the hides, to clean them, while at the same time it opens their pores, so that they imbibe the tannin more rapidly. It also precipitates or decomposes a portion of the coloring matter of the ooze, and thereby renders the color of the leather lighter, more lively and beautiful.

If there is a deficiency of acid, so as not to neutralize all the alkalies remaining in the hides, they will be spotted or dark colored. They will not raise or swell up. In such case, more of the sulphuric acid must be added for the purpose of decomposing more of the salt (which is supposed to be in excess) and thus furnish more of the muriatic acid.

N. B.—Muriatic acid of commerce may be added to the tannin and salt, and they will produce nearly the same result; the sulphate of soda would be wanting, but this also may be added, and then we should have the same composition, and precisely the same results; and when economy would warrant it, this course might be adopted, but at the present cost of these materials, it is cheaper to use sulphuric acid and salt, and thus generate both the muriatic acid and sulphate of soda; this method is also more simple.

The hides and skins having been prepared in Composition No. 1, as already described, they are then to be put into Composition No. 2, prepared as above, in suitable vats, and handled often in the usual way. The strength of the composition must be kept up by additions of strong ooze, and also of salt and acid when necessary, and in such quantities as will give the original taste, color, &c.

The time required to accomplish the process of tanning will depend on the quality and size of the hides or skins, or kinds of leather to be made, and on the strength and temperature of the composition. If the strength be good, the temperature about 80°, and the handling properly conducted, most kinds of leather may be tanned in less than half the time required by the old method of tanning now in use in our country. When the hides are sufficiently tanned, those designed to be curried may be curried and finished in the usual way. If the process has been properly conducted, they will require much less scouring, whereby some hard labor is saved.

When it is intended to black and finish on the grain, in order to remove any excess of salt and acid that may remain in them and interfere with the finishing, after removing them from the vats, soak them an hour or less in a clear ooze, made of the same kind of tannin used in tanning them; then rinse and strike them out of clear soft water, after which immerse them in the following composition:—To every gallon of soft water add, of good soft soap 1 quart; best sperm or cod oil, 1 pint. Mix and beat these ingredients well together; after being dipped in this mixture let them "sammy" or dry partially, then sham set and stuff them. For stuffing use common stuffing and soft soap, equal parts, or sad and cod oil, equal parts; after which, if to be finished on the flesh side, proceed in the usual way, but if to be blacked on the grain, wet or sponge them, when nearly dry, on the grain side with a weak solution of potash or sal soda, then apply a thin coat of blood and acetate of iron, as used by morocco dressers; let them nearly dry, then repeat the coat of sal soda, and mixture of blood and acetate of iron. Then set them smooth on both sides, and oil and dry them.

Deer, sheep, and similar skins, designed for buck or imitation of buck, such as are used for gloves, mittens, and military trimmings, should be "frized" after being prepared in Composition No. 1, and unhaird; and then tanned in Composition No. 2, prepared with sumac. When tanned, rinse and strike them out of clean soft water, then hang up to dry. When dry, finish on a perch with a stake, moon-knife, and pumice stone; or, to make them soft and elastic, they may be milled first,

before quite dry, and then finished with perch, moon-knife, &c., the same as in oil dressing, but without any oil.

In order to tan hides or skins with fur, hair, or wool on, they must first be washed thoroughly clean in a weak potash lye, or in soft soap and water (care being taken not to keep them in so long as to start or loosen the fur, &c.), then flesh and break them; rinse in clean soft water, then tan them in Composition No. 2. To make white leather, sumac should be used in making composition No. 2. What I claim and desire to secure by Letters Patent, is, first, the process of removing the hair and wool from hides and skins, and of liming them, so called, preparatory to tanning by the use of a composition of lime, wood ashes or potash, and of salt, called composition No. 1, in the manner above described.

I also claim the use of a composition of lime and wood ashes or potash, without the salt, but I do not claim either of these materials separately by itself.

Second, I claim the process of tanning hides and skins by the use of any kind of tannin, in combination either with the muriatic acid of commerce, or with muriatic acid generated by a mixture of sulphuric acid and salt in water, with the tannin, in the manner substantially as above described.

[There is more than one part of this patent respecting which we have a few remarks to make:—first of all there is claimed "lime, wood ashes, or potash, and salt," for removing the hair, &c. Now, Profs. Page and Gale of the Patent Office, are chemists, and we would say, "what, in chemistry, is the difference between wood ashes and potash? None. Potash is just crystalized woodashes: there is not a backwoodsman from Maine to Oregon, but knows this, yet in this specification they are spoken of as almost different substances. It is also stated, in the specification, that lime, wood ashes, or potash, and even salt have been used separately. We do not know about the salt, but lime and ashes have been used in combination more than twenty years ago. (See page 439 Glasgow Mechanics' Magazine, 1826). And what is the composition of lime and potash but the old caustic lye of the bleachers for removing grease, &c. It forms a saponaceous compound, as expressed in the patent, when brought into contact with animal substances; this fact is as old and well known as the Falls of Genesee. The salt is the only thing which appears to be new in the composition; we cannot see what good it can do, nor what evil.

The tanning composition is a singular one, very: "salt, sulphuric acid, and tannin." The salt is the only thing here, again, that appears to be new in the composition. Sulphuric acid was used in the tanliquors thirty years ago. The muriatic acid of the salt, we are told, is set free, sulphate of soda (glauber salts) is formed, and the muriatic acid, being absorbed by the water, acts on the alkalies, which may yet remain in the skins, &c. Well, gentlemen tanners, would you like to know some other chemical substances which would produce the same effects, (rather better), and which would be less in number? Yes. Well, then, instead of using salt or potash in your milk of lime, use sal soda alone. This will make a lye of the same nature, and produce the same effect. In your tanning liquor, use only a little sulphuric acid; it will combine with the lime and soda, forming plaster of Paris and glauber salts, "raising the hides" at the same time. We believe, however, that it would be better to put the hides to steep for an hour or so (after being washed from lime) in a very weak solution of water and sulphuric acid, after which they should be washed, and are then ready for the bark. These views of ours are based upon chemical knowledge, we know they are correct, and to claim a patent for their application, would be like claiming a philosophic principle. Great care should be exercised in the employment of alkalies in tanning; hasty tanned hides often give force to the old proverb, "soon ripe, soon rotten."

If strong lye is used the hides will be injured, caustic alkali will reduce hides to a jelly if the liquor is kept warm.—[Ed.]

New Inventions.

Great Improvement in the Piano Forte--- Piano, Flute, and Viol all Combined.

Mr. R. M. Ferris, of this city, has taken measures to secure a patent for an improvement in the pianoforte, termed the "Flute and viol d'amour" which will astonish the community one of these days. The arrangement is very ingenious, and the sweet music discoursed falls upon the ear like the songs of the Fairies. The combination of the parts is such that either the organ or piano can be played separately or combined by the same set of keys, or by one hand. The invention does not consist in combining the flute notes with the piano, but the manner of doing so. There are two sets of keys, which can be played by the one hand or separately. The improvements are of no common character, and cannot fail to create a sensation in the musical world.

Improved Railroad Brake.

R. M. Wade, of Wadesville, Va., the patentee of the spark catcher, illustrated in our columns last week, has taken measures to secure a patent for an improved brake which is worthy the attention of railroad men. He applies the necessary power to separate the brake by means of chains attached to levers, in communication with the brakes, and to the periphery of a drum which is hung loosely upon one of the driving axles, but is governable by a clutch under the control of the engineer or brakeman, and can be made to revolve with the axle and wind up the chains upon the periphery and thus actuate the levers.

Libbey's Leather Car for raising Hides from Vats.

Mr. Orrin Libbey, of Cooperstown, Otsego Co., N. Y., has invented a car for raising hides from vats, which is a great improvement in the mode of doing this work, enabling one man to do with great ease that which requires a number to perform by the slow process of hide after hide. A truck runs along rails at the side of the vats, and on this truck is a windlass with which the hides are lifted up and laid on the truck, and then they can be deposited in the same way.

Mr. Libbey has applied for a patent.

Improvement in Shuttles

Mr. L. Litchfield of Southbridge, Mass., has taken measures to secure a patent for a valuable improvement in shuttles for power looms. The improvement consists in making the spring and spindle in one piece, and so constructing them that one shuttle will answer for bobbins with different sized heads, thus making the shuttle more suitable for woolen factories especially. There is no fear also of the spring catching the thread, as in the old shuttles, when the springs are fixed with a screw on the bottom of the shuttle. The screw often gets loose, but there is no such thing as a screw in the improved shuttle.

Improved Machine for Punching Leather Hose, Harness, &c.

Mr. Henry Wilson, of Orwell, Bradford Co., Pa., has taken measures to secure a patent for a very excellent improvement in the apparatus used by saddlers for punching hose for fire engines, &c. A lever is made to operate the punch and withdraw it, so as to pierce the hose in the holding jaws, which are opened and closed by a cam actuated by a band passing over the periphery of a pulley connected to a pair of treadles, which are operated by the feet of a person sitting on the bench of the machine. The stitching can be performed in the same jaws, the punching preceding with the feet, while the hands follow after to close up by stitching. The leather for harness or hose is moved regularly forward by the machine, the exact length of a stitch every stroke. It can punch band iron for trunks, as well as hose and harness.

A very extensive quarry of soapstone has been discovered on the farm of Mr. Enoch Gibson, of Canterbury, N. H. Mr. Gibson disposed of his right in the soapstone for \$8,000.

Ison's Improvements in Machinery for Making Spikes and Nails.

(Continued from the First Page.)

arrow, 1, (see fig. 3), and the iron being previously heated, is brought either directly from the rolls or otherwise, in the direction of the lines shown in figs. 1 and 2, on to the upper plate, I, of the table, and its end is presented a sufficient distance over the edge, e, to have a strip cut off of suitable width to form the spike, when the vibrating shear arm, K, will be brought down, and will cut off the overhanging end of the iron between its edge, m, and the edge, e, of the opening, b, afterwards forcing it down into the opening and

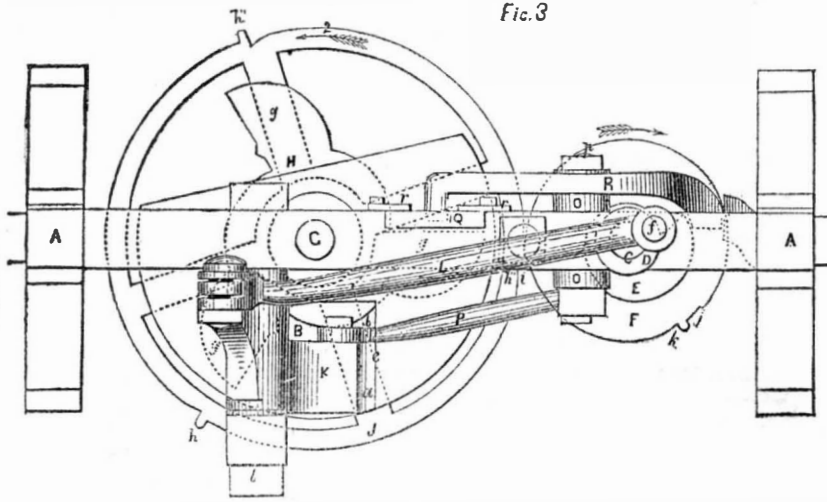

friction of the two wheels being diminished, while the next spike is cut off and pointed by another descent of the shear arm, the iron from which the spikes are made being moved forward previous to every descent of the shear arm. By the motion just described as being given to the wheel, J, and shaft, G, the carrier, H, receives a corresponding motion, and carries the spike first cut off between the plate, I, and the lower part of the table, B, to a position under the heading die, where, on becoming stationary, it allows it to remain. During the time that it is stationary, the cam, E, operating on the lever, R, brings down the holding die, and the header, being brought forward by the next downward stroke of the shear arm, the head is upset or turned round the corner of the holding die, Q. As soon as the head is formed, the holding die is raised by its lever, R, being forced by the spring, S, against the less prominent part of the cam, E, and the header is drawn back by the upward motion of the shear arm, and by this time the wheel J, and shaft, G, begin their motion again, and the arm of the carrier, which brought the spike to the header, pushes it out from the machine, the next arm behind it bringing the spike last cut off and pointed to

down on the lower part of the table, B, where it will form the point; the shaft, G, and carrier, H, being stationary while the iron is being cut off pointed. The shear arm will, after the cutting off and pointing, commence its upward motion to release the spike, and as soon as this upward motion commences, the tooth, l, on the wheel, F, comes in contact with one of the teeth, h, h', or h'', on the large wheel, and sets the shaft, G, in motion, giving it one-third of a revolution in the direction of the arrow, 2, (fig. 3), after which the point, i, on the wheel, F, passes the next tooth on the wheel, J, and it (the wheel J) and the shaft, G, become again stationary by reason of the

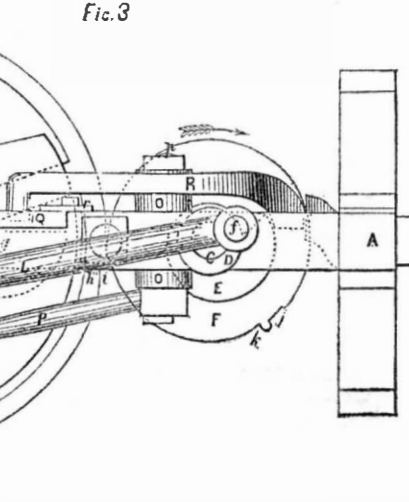

a suitable position to be held by the holding die, Q, and headed. This operation is repeated as long as the machine remains in motion, two spikes being always operated upon at once, one being cut off and pointed, while the one cut off and pointed before it, is being headed. In figure 1 a spike is shown just cut off, and under the shear arm being pointed; in fig. 2 one is shown being headed.

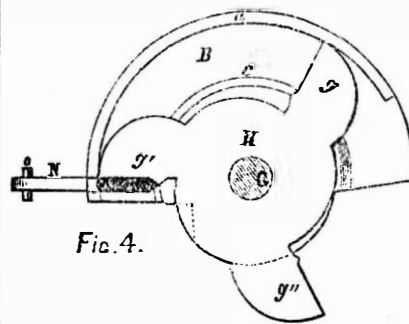

From the foregoing description, and the excellent manner in which it is illustrated, its construction and operation will be fully understood. Other information may be obtained of Mr. Ison by letter addressed him at his residence mentioned on the first page.

Currents of the Ocean---Pendulum Experiments.

When anything obscure and difficult of explanation is brought before the public, especially if it is beyond the experience and grasp of common minds, it is wonderful to see what a rush there is for distinction,—men who were never accounted very philosophical, at once stand out in bold relief as the "noblest Romans of them all." The pendulum experiment to demonstrate the rotary motion of our planet, has made more philosophers than any discovery, we believe, of modern times. We have a pile of communications on the subject, of no common dimensions, every one of them proving the truth of Seba Smith's New Elements of Geometry, viz., that a line has both length, depth, and breadth (one argument for the Professor, we hope). Owing to the propensity of some men to speculate and theorize, independent of facts, it is very likely that fifty or perhaps a hundred new theories will spring up out of Foucault's experiment.

We see that Mr. Wilkins, in the N. Y. Tribune, endeavors to demonstrate that the currents of the ocean can be easily accounted for by this experiment; rather, he asserts that there are no ocean currents at all—that the currents of the ocean are merely imaginary. He proves this by making a vessel of water revolve on a table, the vessel moves "but the water does not." If this was proof positive,

then a vessel standing still in the midst of the Atlantic could not detect any current, "there being no current." The Gulf Stream, however, proves the contrary theory, for it often washes, up the products of the New World on the coasts of the cold, a thing which it otherwise never could; and besides this theory entirely leaves out the result of centrifugal force

Roofing the Britannia Tubular Bridge.

A singular and novel process, says the London Times, is at present being carried on with respect to the Britannia Tubular Bridge. In consequence of the upper surface of the tubes receiving and being acted upon by the wet, it has been deemed advisable to roof the top of the tubes; and for this purpose a complete ridge has been placed over both the tubes, having a walk down the centre, and the frame work has been completely covered over with cloth impervious to the rain. Upwards of 7,000 yards of this prepared cloth are required to accomplish the undertaking, which has been taken by contract. The large hotel, which it has been determined to erect closely adjacent to the bridge, will contain 500 beds, and will be connected with the tubes by a covered walk and surrounded with appropriate gardens, pleasure grounds, &c. The works for the erection of this monster hotel are in full operation; large bodies of laborers are employed in leveling the ground and forming the foundations, and no time will be lost in the completion of

this adjunct to the Chester and Holyhead and Carnarvon lines.

New Rate of Postage---Important Information for the Subscribers of the Scientific American.

On the 1st of July, next Tuesday, be it remembered by all, the new rates of postage as passed by the last act of Congress come into force. The great reduction of the postage on newspapers we believe will tend to increase the circulation of them all over the country, and we expect with other publishers and the public to be benefitted by the reform. The Scientific American, under the new law, as will be perceived by the legal rates of postage which will be henceforth charged upon it to regular subscribers, will cost our mail patrons much less per annum than it has heretofore, and we cannot but hope that thousands of new ones may be added to our already 16,000 pre-paying patrons.

The following rates of postage we have copied from the official tables, it being the rate charged on the "Scientific American" for each quarter (3 months) payable in advance at the office where received.

To subscribers in N. Y. City and County,	Free
Within 50 miles of New York,	5 cts.
Within 300 miles and over 50,	10 cts.
Within 1,000 miles and over 300,	15 cts.
Within 2,000 miles and over 1,000,	20 cts.
Within 4,000 miles, and over 2,000,	25 cts.
Over 4,000 miles,	30 cts.

NOTE—The last rate includes California and Oregon.

Patent Case---Carpet Loom.

A trial came off last week in the U. S. Circuit Court, Boston, being the case of E. B. Bigelow, the famous inventor, and Mr. Barber, for the infringement of two patents. The question was a complicated one, and was the first trial of the two patents, which covered a variety of improvements by means of which the Jacquard power loom was made applicable to the weaving of carpets. The plaintiff alleged that the defendant infringed on each of these patents by using his improvement of the Jacquard machine, and also his method of making a regular and measured figure.—This was denied by the defendant, who also set up the defence, that each patent was invalid for want of novelty. The jury found both patents to be valid, and that each was infringed by the defendant. In answer to a question by the court, the jury said they did not regard a particular kind of let off, described and claimed in the plaintiff's first patent, as original with him.

The nominal damages were \$10 for the first and \$5 for the second count.

In the two patents in question, there are twelve distinct claims. MACHINIST.

Lowell, 20th June.

Improved Oil Cup.

Mr. Aaron Richardson, of Bellows Falls, Vermont, has taken measures to secure a patent for an improvement in oil cups for lubricating the journals and other parts of machinery, which consists in providing the inside of the cup with a valve fitting in a seat around the mouth, and held by a spring so as to close it and exclude dirt, but yield to the slightest pressure of the spout of a feeder, to fill up the cup, and then forming—when the pressure is removed—a self acting stopple.

A petrified snake was recently dug up at Powers Summit, on the Ohio and Pennsylvania Railroad. It was found imbedded in the limestone rock, some sixty feet below the earth's surface. Its size is enormous, sixteen feet in length, and in the middle at least four inches in diameter. Although its substance is completely assimilated to the rock in which it was imbedded, it looks surprisingly natural—indeed almost as perfect in "form and feature" as when alive.

The Carew Paper Manufacturing Company, at South Hadley Falls, are boring an artesian well to supply their mill with clear water. At the depth of 26 feet they have a stream above the capacity of an ordinary pump to dispose of. It is intended to go down 100 feet. Thus far the boring is through solid rock.

Scientific American

NEW YORK, JUNE 23, 1851.

The Recognition of Genius and the Industrial Principle.

There has been a cheering and gradual advancement of sound principles during the past century. In the days of old, what were our forgers of iron and workers of brass, but the mere appendages of the State. The fighting and talking men alone were the recognised parts of it; eloquence and military skill were the true and almost the only passports to honor and distinction. The producing useful classes were good enough to be called *villians*, and their occupations *degrading* and *vile*. Like the fop in Henry IV., the mechanic could not pass by one of your blood and monied nobility but the latter had to use his pouncet-box, lest his patrician sensibilities should be shocked. The trade degraded the man. Some change has been made in the social advancement of the hard handed and brown-browed toilers, though, as a general thing the trade is still held to lower the man. The progress made is definitely marked in political advancement. In France, England, and the continent of Europe, the mechanics and artisans labored under the most unjust and exacting laws for the benefit of the nobility and favored monopolists. In France and England these unjust laws have been swept away, and so they have in many of the German States and Kingdoms. In the United States of America alone among all the nations of the world, the political rights of the mechanical classes are recognized. Here they stand on a level with every other class. It will yet come to this in other lands, and the great exhibition of the industry of all nations is one of "the signs of the times." The monopolies of trades and the mercantile monopolies—those odious enactments of the Stuarts—have crumbled away, and genius, enterprise, and industry, are now found to be the aristocrats which rule the world. Your jousts and tournaments; your royal military camps and gorgeous reviews, all dwindle down into utter insignificance when compared with the "Crystal Palace"—its external and internal triumphs. Men are now becoming something for what they can do and what they have done, not for what their fathers were. The aristocratic principle is the past part, the industrial is the present. It is true, the great exhibition was designed by a Prince and is under the patronage of royalty, but the designing and patronizing of it, and the broad democracy of its whole management, are evident signs of the times, in the recognition of the aristocracy of genius and the industrial principle. That nation which most encourages and rewards genius and industry, understands its true interests best. The nation which produces most is the most powerful; this is well understood by all enlightened statesmen, hence we have the congress of industry now in London. How is it that the little kingdom of Great Britain, not so large as Virginia, exercises dominion over 200,000,000 of people situated in every quarter of the globe? By her genius and industry. Her Watts, her Arkwrights, her Cartwrights, Bells, Napiers, and Stephenson are the real levers of her power. In America industry has a wide scope—a broad sea and a fair wind. We have no guilds to make such a man as Sir Joshua Reynolds pay large fees, because he has not enrolled himself in the worshipful company of "painters and stainers." No Watt has to take refuge within the walls of a university to free himself from the feudal exactions of his fellow craftsmen. And what can we show for this industrial freedom? Sir H.L. Bulwer has said "no people in the world are so lightly taxed and powerfully protected," and let us add, produce so much of the essentially useful.

Much improvement has yet to be made in recognizing these principles in all their length and breadth. Moral worth is no doubt the first grand principle, but there is certainly a moral in recognizing the right. Drones should be assigned their true position in society, and

the cloth should not receive more homage than the man who produced it. By a full recognition of the claims of genius and industry, by all nations and all men, we expect yet to behold an era of inventions and discoveries, in comparison with which, the past great as it is shall be as the river Thames to the majestic Mississippi.

Pennsylvania Chrome Mines.

On the Octorara River, which separates Chester and Lancaster counties, there is Wood's chrome mine, about nine miles from Nottingham, which is about 170 feet deep, 200 feet long, and about 30 feet broad. This is considered to be the largest chrome mine in the world; and the researches and analyses of

several chemists both of this country and Europe have ascertained that it yields the best ore, being nearly pure bi-chromate of iron, 93.384 is oxide of chrome. The mine has been worked about fifteen years, with a brief interruption.

The site of this mine is represented as offering—what, indeed, the whole region has long been—a rich field of interest to mineralogists. It abounds in magnesian and chrome minerals, yielding also beautiful specimens of emerald, nickel, pennine, kammererite, marmolite, &c.

The magnesian ore is found in horizontal veins in serpentine, some of which have been followed into the side of the hill nearly 100 yards.

HOLLOW BRICKS FOR HOUSES.

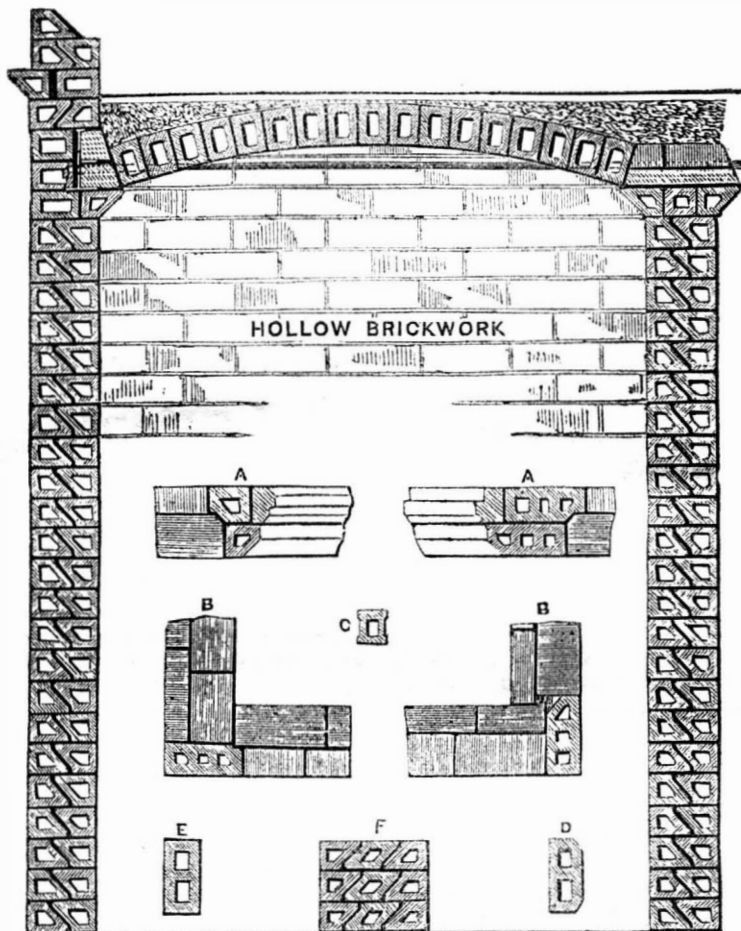

The accompanying engraving is a section of one of Prince Albert's model lodging houses erected in Hyde Park, London, and the model of which is in the "Great Exhibition."—Always endeavoring to present to our readers that which we consider new and useful, and as these houses had been spoken of in terms of the highest praise by some of our countrymen who had visited them, we thought it would be interesting and at the same time advance art by presenting this view of the building. The hollow brick is the subject of a patent by a Mr. Roberts, as noticed by us in Vol. 4.

A A is a plan of the window and door jambs on alternate courses; C is a partition of brick; E, square jamb and chimney brick; F is a section of a wall; D is a section of chimney brick.

The advantages derivable from the use of hollow bricks are dryness and warmth, as well as economy of construction—considerations which recommend them as a preventive of the evils that result from the absorption of moisture by common bricks and other porous material.

They are adapted for houses of moderate height, but are not so strong as the solid brick, but their strength may be adapted to circumstances, and they are much stronger weight for weight.

When used for partitions, or for roof and floor arches, they are fire proof, deaden sound more effectually, and are considerably lighter than solid brickwork.

By the form adopted in the patent hollow brickwork, a perfect bond, running longitudinally through the centre of the wall, is secured; all headers and vertical joints, passing through it, are avoided; internal and external strength is obtained; and every facility given for the fixing of floor-plates, and other

timbers; whilst, by the parallel longitudinal cavities, ample security for dryness is afforded, and great facility presented for ventilation, as well as for the conveyance of artificial heat, and for the transmission of bellwires, and pipes.

Hollow bricks may be made, with any good tile machine, in the same manner as ordinary draining pipes, and at about the same cost in proportion to the quantity of clay contained in them. They are more compressed, require less drying, and with much less fuel are better burned than ordinary bricks, even when waste heat, or that in the upper part of the kiln, only is used.

The saving in brickwork effected by the use of the patent bricks, when made at a fair price, is said to be from 25 to 30 per cent. on their cost, with a reduction of 25 per cent. on the quantity of mortar, and a similar saving on the labor, when done by accustomed workmen. The process of drying is much more rapid than in the common brickwork, and the smoothness of the internal surface of walls built with the patent bonded bricks renders plastering in many instances quite unnecessary, whereby a further saving is effected not only in the first cost, but also in the subsequent maintenance. If glazed on the outer face, as may be done with many clays, a superior finished surface is attainable without plaster.

Errors in Printing.

Some hundred years ago a number of the Professors of the Edinburgh University attempted to publish a work which should be a perfect specimen of typographical accuracy. Every precaution was taken to secure the desired result. Six experienced proof readers were employed, who devoted hours to the

reading of each page, and after it was thought to be perfect, it was pasted up in the hall of the University, with a notification that £50 would be paid to any person who could discover an error. Each page was suffered to remain two weeks in the place where it had been pasted, and the Professors thought that they had attained the object for which they had been striving. When the work was issued, it was discovered that several errors had been committed—one of which was in the first line of the first page.

Cast Iron Buildings.—Crystal Palace.

A correspondent of the National Intelligencer claims for our country the original conception and first development of the principles on which the crystal palace has been constructed. He awards the laurel to Mr. James Bogardus, of this city, and says his invention embraces three distinct ideas—"First, the application of cast iron for the purpose; next, the bolting together of the huge pieces composing the frame of the building, so that they will not only withstand any probable strain in any direction, but also, if perchance any one piece should fall, the stability of the rest will not be disturbed; and, lastly, the construction of all the joints much after the fashion of the joints of the ordinary cast-iron ten-plate stove; so that, while allowing for the contraction and expansion of his metal under all possible changes of temperature, whether from the cold of winter or from an accidental fire, his buildings shall not be objectionable on account of exposing their interior to the elements."

He also says, Mr. Bogardus visited Europe in 1836, and went to England in the hope of being able to interest capitalists of that country in his scheme. The subject was urged by him there in vain for a year or two; the British writers on mechanics generally concurring in the belief that he had mistaken the capacities of his metal.

The statement is also made that the scientific principles upon which the construction of cast-iron houses is based were applied for the first time in England in the construction of the Crystal Palace, and that the houses which had previously been built there are all wrought-iron, as are all the iron buildings so far put up on the Continent, as well as those which have been sent from Europe to California. The latter are joined and stayed on the principles applied in the construction of the steam-boiler, and cannot withstand the action of fire, as if made of cast metal; while they cannot be put together in a day, or be taken apart without destroying them.

Mr. Bogardus, no doubt, is one of the most ingenious men, and best mechanics the world has ever produced. We make this assertion unreservedly in all its length and breadth, but then instead of conferring honor upon our country, by undervaluing the claims of the inventors of other nations, it takes away from our honor and lowers our dignity. Mr. Paxton, we believe, is the sole inventor of the Great Exhibition Building, and a man of splendid intellect and ability. Mr. Bogardus erects the best cast-iron houses, we believe, in the world, but neither Mr. Bogardus nor Paxton were the first to use cast-iron in buildings, and the principles of erecting and securing cast-iron structures were known and carried into execution before either of these two eminent men came upon the business stage.

The great principles of cast-iron houses were developed long ago in cast iron bridges. Mr. Frost, of Brooklyn, built a cast iron bridge in England, 30 years ago, and the Southwark Bridge, London, was built about 1815, we believe, and is principally of cast-iron. It is a splendid structure of three arches, and is one fourth of a mile long. As to the material "cast-iron" never having been used in structures in England, before it was applied in the Crystal Palace; this is all nonsense. A small cast-iron lighthouse was erected in the city of Glasgow, by Claud Girdwood, in 1824, and it may be there still. An account of it can be found in the Glasgow Mechanics' Magazine. The Crystal Palace will go down to posterity as a disem to the genius of Paxton, and the cast-iron houses of the United States will be enduring monuments to the genius of our Bogardus.



Reported expressly for the Scientific American, from the Patent Office Records. Patentees will find it for their interest to have their inventions illustrated in the Scientific American, as it has by far a larger circulation than any other journal of its class in America, and is the only source to which the public are accustomed to refer for the latest improvements. No charge is made except for the execution of the engravings, which belong to the patentee after publication.

LIST OF PATENT CLAIMS

Issued from the United States Patent Office.

FOR THE WEEK ENDING JUNE 17, 1851.

To Mahlow Gregg, of Philadelphia, Pa., for improvement in Brick Machines.

I claim the rotating mould wheel, constructed as described, with a series of moulds in its periphery, and an annular plane outside of the moulds, and furnished with pistons arranged as described, for the purpose of discharging the bricks from the moulds, as set forth.

I also claim the mode herein described, of changing the position of the pistons by means of the bar attached to the horizontal presser, with its block and plate which are made to impinge upon the vertical plates, which are attached to the pistons for that purpose.

I also claim the combination of the hopper, horizontal presser, vertical presser, and hook rod, with the transverse horizontal lever and with the mould wheel; the whole being constructed and arranged in the manner and for the purposes described.

To H. W. Hayden, of Waterbury, Conn., for improvement in the construction of Dies.

I do not claim to be the first to construct a die with a lined surface, to deaden the metallic surface operated on, but I claim the application of a die, with a lined or corrugated surface, with the figure or pattern cut, or countersunk, so that the lined surface deadens the plate of polished metal, and leaves the polished surface of the figure untouched, for producing ornamental designs on polished metallic surfaces.

To Elias Young, of Cincinnati, Ohio, for improvement in Cooking Stoves.

I claim the cold air passages, substantially as arranged, to wit: having each an external aperture, near their upper part, on each side, beneath which projects a plate that carries the air to the centre of the stove, whence, by a second plate beneath the middle of the passage, it is again deflected to the outer ends of the passage, (thus counterbalancing the cooling effects at its entrance, whence it is distributed in hot blasts, to the fire.

To Wm. T. Barnes, of Buffalo, N. Y., for improvement in Wash Boards.

First, I claim fastening cloth, or its equivalent, on the board to prevent fine fabrics from slipping and from being torn or rubbed too much; but I do not claim lining the grooved washboard with india rubber, or other equivalent material.

Second, I claim hinging the washboard to the frame, for the purpose of holding the clothes while being washed, and at the same time allowing the board to be turned over, substantially as set forth.

To Ransom Cook, of Saratoga Springs, N. Y., for improvement in Augers.

I claim the form of the tips or cutting edges of boring implements, as described, that is, such tip commencing at the screw or centre point, and running nearly at right angles thereto, until about half way from the centre to the outer part of the boring implement, when it assumes a curve upwards, or towards the handle end of the instrument, which curve is continued until it is nearly semicircular, or until it turns within the periphery of the auger or bit, the curved edges being also under-cut or back-sloped, but without being confined to any particular angle of such back-sloping or under-cutting, as set forth.

To Rufus Ellis, of Northampton, Mass., (assignor to Wm. M. Chase, of Boston, Mass., for improvement in Knitting Machines.

I claim the arrangement of the needles in

the plane of the endless belt, instead of at right angles to it, in combination with the arrangement of the driving pinion and the projecting joints, &c., of the links of the belt on the outside of the belt, the belt being supported, and the whole being applied to the stitch hook, yarn guide, and presser, and made to operate together, and with the work hanging on the inside of the belt, substantially as specified.

To Chas. F. Brown, of Warren, R. I., for improved connection of Telescopic Masts and Spars.

I claim connecting and adjusting the several joints of masts, yards, and all spars constructed of telescopic tubes, or tubes fitting one within another by means of a screwed rod or screwed rods (two), nuts, female screws, and set screws, or their equivalents; the whole being inserted in and secured or attached to the tubes, and operating in the manner substantially as set forth.

[This is the fourth patent secured to Mr. Brown through our agency, during the past year, all of which have been illustrated in the "Sci. Am."]

To Seymour Carver, of Geneva, Ill., for improvement in machines for Dressing Shingles.

I claim the arrangement of the head block with the springs, cams, the rollers, and stops, for the purpose of passing the shingles between and out from the cutting cylinders, in combination with the arrangement for depressing the upper cylinder, while in motion, for the purpose of giving a taper to the shingle; the whole combined and arranged as set forth.

To G. S. Griggs, of Roxbury, Mass., for improvement in Ventilators.

I claim a ventilator as herein described, composed of two series or sets of curved slats, arranged one within the other, and running from the edge of the flue or other orifice, to a small circle or plate over the centre of the same, the whole forming a conical or globe-shaped ventilator, the spaces between the several outer slats being protected by the inner slats, having spaces or apertures between the two sets of slats, the only openings to said apertures being in an oblique or sideways direction, all as set forth.

To W. O. Hickok, of Harrisburg, Pa., for improvement in Regulators for the pen beam in Ruling Machines.

I do not claim to be the inventor of the flexible hooked regulator, attached to the pen beam, but I claim the pieces in combination with the hinge joints, arranged and combined substantially as described.

I also claim the sliding piece, the bearings, and the finger wheel, in combination with the other pieces, uniting by hinge joints, or in any other manner substantially the same, using, in the construction of the whole machine, any material adapted to the purpose of forming, as described, a pen beam regulator for ruling machines.

To Chas. Anderson, of Warsaw, Pa., for improvement in Revolving Boilers.

I claim lining the inside of that part of a revolving boiler which comes in contact with the fire or heat, with wire gauze, or cloth, or any perforated or pervious metal work, in the manner and for the purposes substantially as described.

[See engraving in No. 34, this Vol. Sci. Am.]

RE-ISSUES.

To Esther L. Larkin, Adm. of J. E. Larkin, deceased, of Ballston Spa, N. Y., for method of attaching augers to their handles. Originally patented Nov. 19, 1850.

I claim the handle made in two parts, one of which fits in a socket on the other, and carries a bolt screwed at its end, the said bolt passing through a hole in the auger shank, and screwing into a female screw, or nut, in the part on which is the socket, for the purpose of clamping or firmly holding the auger shank between the ends of the parts of the handle or stock, substantially in the manner described.

DESIGNS.

To J. G. Lamb, of Cincinnati, O., for two Designs for Stoves.

A bed of peat of the purest quality has been discovered within four miles of Saratoga, N. Y., covering about 60 acres. Excavations have been made to a great depth, without finding any bottom to the strata. It is said to be much cheaper and far superior to coal in its use for stoves or grates.

(For the Scientific American.) Practical Remarks on Illuminating Gas.

[Continued from page 318.]

Air deprived of its oxygen, then, is unfit for respiration and cannot support combustion; therefore it becomes necessary to re-establish this important element, and remove the vitiated gases from the apartment; for this purpose a well arranged system of ventilation is highly important. By good management, any of the materials above enumerated, excepting tallow candles, can be burned without smoke; hence the products incidental to their combustion are not seen, nor are their effects immediately felt; they are therefore scarcely ever thought about, unless the apartment becomes over-heated and the atmosphere rendered insupportable.

The injurious effects and unpleasant sensations experienced in crowded or ill-ventilated rooms, is not so much caused by the heat, as the invisible gases which are evolved during combustion; for a high temperature can be borne without much inconvenience, provided the air be pure.

We have said that the products of combustion are alike, whether lamps, candles, or gas lights are used, but vary in quantity according to the relative proportions of light. This will explain why a gas burner, yielding light equal to twelve or fifteen candles, will warm a room more quickly than two or perhaps three candles; and this explains why the air in a room is heated, and otherwise unpleasant to the feelings, more quickly after gas lights are introduced than before. It must be known that the vitiated or deoxygenated air, together with the vapor and heated air, being lighter than the common atmospheric air in the room, ascends and collects in the upper part of the apartment, while the carbonic acid being of greater specific gravity than the air, descends and forms a strata at the lower part of the apartment, so that in order to ensure proper and thorough ventilation, openings should be made of ample capacity, according to the size of the room, and not only at the top of the apartment, whereby the impure air may escape but also at the bottom for the exit of the carbonic acid gas, which may accumulate in buildings tightly made; and where fire places are not used, a well arranged system of ventilation is highly important; and no system can be successful unless it provides for the altered circumstances at night, when shutters are closed, curtains are drawn, lights are introduced, and when a greater number of persons are assembled in the room than on ordinary occasions.

We are so much influenced by habit that it frequently usurps the authority of reason.

Thus, when the shutters are closed, the curtains drawn, the outside doors kept shut, and lights introduced—conditions which all conspire to make the room warmer than during the day, instead of letting the fire down, so as to accommodate it to these altered circumstances, it is generally trimmed afresh, and then the room is overheated.

In the practical details of warming, lighting, and ventilating apartments, we can follow no safer guides than natural processes.

Suitable allowances must be made, and some modifications are requisite, on account of variable conditions. But the most simple, efficient, and economical plans for securing comfort and health within doors, are these founded on the plainest intimations of what takes place out of doors.

The following result of an experiment by Mr. Rutter gives the temperature at the expiration of each hour; at different distances from the floor, the experiment was performed with one gas light.

5 feet from floor	10 feet from floor.
Commencement 62°	Commencement 64°
1st hour 64°	1st hour 70°
2nd " 66°	2nd " 74°
3rd " 68°	3rd " 77°
4th " 68°	4th " 78°
5th " 69°	5th " 78°
6th " 69°	6th " 78°

All the fittings such as pipes and cocks should be of the best materials and perfectly tight. Much injury is done by leakage.

GENERAL REMARKS.—Not unfrequently gas

consumers remark that their bills for gas are exorbitant, and it is with difficulty they can be convinced they have consumed as much as the faithful little instrument, the meter, indicates. Many severe deprecations have been put upon this instrument, and severe epithets have been poured upon gas companies and their agents, by consumers who do not understand the principles of the meter, nor take the pains of informing themselves, and who do not exercise discretion in the consumption of gas. The ease with which this ever-ready light is obtained, is a great accessory to its wastefulness, for by the mere effort of the will, it can be increased or diminished; so simple a thing is it to turn a cock, that it is often done in haste and without thought, and if opened more than is necessary, large quantities escape, and if more gas escapes than there is oxygen enough to support its combustion, it passes off unconsumed, and therefore wasted.

The methods of burning illuminating gas have, up to the present time, commanded but little attention from the great portion of those persons who daily use it, and a few practical remarks relative to its economical consumption may not be unworthy of the reader's attention. Many different varieties of gas burners have been constructed in this country as well as in Europe, each claiming to possess advantages over prior inventions; those which have been most commonly adopted in this section of the country are the Argand, the Batswing, and the Fish-tail burners. The former is considered as the best of those enumerated, not only as regards its light-giving qualities, but also for its more perfect combustion of the gas; it gives a cylindrical flame similar to the lamp of the same name, the gas being supplied to it through a ring perforated with small holes about 1-32nd of an inch in diameter. It is surrounded by a glass chimney, which forms an essential appendage to this description of burner, its use being to create a draft and direct the current of air through the flame. The slight noise which is sometimes noticeable with these burners is caused by the rush of air, created by the draft through the chimney. If the flame of an argand burner is turned up high, the air which rushes through the interior of the ring becomes decomposed before it can reach the air on the top of the flame, which consequently burns in one undivided mass, the result of which is, the gas is only in part consumed, and carbon is deposited abundantly. If we shut out a portion of the air by partially closing the apertures in the burner, we sensibly increase the amount of light, but at the same time we subject ourselves to the risk of a greater loss, as well as the injury which may arise from smoke; for should the pressure in the street mains be increased by the extinguishment of a number of lights in the city, we should then find our burners smoking, because by shutting out the air by partially closing the apertures, we had deprived them of the necessary amount of oxygen which they required for complete combustion. One cubic foot of carburetted hydrogen gas requires for its proper combustion and conversion into carbonic acid and water ten cubic feet of atmospheric air; an argand burner, with the flame about 2½ inches in height, consumes 3½ cubic feet of gas in one hour, and therefore requires for its perfect combustion not less than 35 cubic feet of air. The Batswing and Fish-tail burners are used without glasses, and are well adapted for the use of manufacturing establishments, street illumination, &c. The former has a narrow cut or slot through which the gas issues, and the shape of the flame is flat, much resembling a bat's wing; the latter has two small holes, so constructed that the two jets of gas intersect each other near the orifices from whence they issue; the flame produced is flat and not unlike the tail of a fish. These burners require much less attention than the argand, and, comparatively speaking, but a limited quantity of gas can pass through them, which renders them very desirable in manufactories where they are regulated by inexperienced workmen.

(To be Continued.)

Three hundred new houses were built in a few days, on the blackened ashes of San Francisco. It takes the Americans.

TO CORRESPONDENTS.

E. W., of Damascusville.—The drawing of your churndash represents precisely the same feature of three others that have been sent to us for examination within a month, none of which are patentable.

J. C., of Mass.—We don't know what you mean by a spindle valve, although puppet valves are usually operated by a spindle, and many safety-valves also are operated in the same manner.

W. P. C., of Pa.—It is not our intention to say anything more about the pendulum experiment for the present.

W. J., of Mass.—The Water Balance Wheel is objectionable on one account. If the water is thrown out of the valve, it has always to be filled up again; it would be a balance wheel of variable gravity.

M. C., of Ill.—Your model is received, and we believe your invention to be a valuable one. On the receipt of the government fees (\$30) we shall immediately take your case up for execution.

H. M., of Vt.—Your reasoning is perfectly correct, and we do not disagree in any one point.

J. B. S., of Wis.—If you will address Thos. Ling, Esq., at Saratoga Springs, N. Y., he will give you more information on the subject of force-pumps and engines than we can.

S. W. A., of Tenn.—Your advertisement amounts to \$1 each insertion—\$52 a year, weekly.

I. J. W. A., of Md.—We have examined the sketch of your contrivance for hoisting substances, and have some doubt of its patentability. It is something on the plan of the "Webber," published in Vol. 5 "Sci. Am." We have seen one made, having a chain passing through holes made in the ends of the levers instead of bars secured by pins as shown in yours. We could not advise you to make an application.

J. H. U., of S. C.—We have communicated the subject of your inquiry to Dr. Field, who will undoubtedly favor you with a reply.

I. F. D., of Brooklyn.—Your plan for using the power of waves would be too expensive for the benefits derived, and of but little use when most required, viz., in calms: we have seen a plan for using the power of waves by side clutch fins, but it was too clumsy for practical purposes.

C. E. L., of Conn.—You know that the brooms are employed for the same purpose as your bar, but the great defect lies in the want of proper guards along the track.

S. S. B., of Ohio.—You are mistaken about the tangent of the wheel at the ground being the centre of motion, the axle is.

C. C., of N. C.—We could not give you the information about the Wool Carding machine, only to direct you to the advertisement of Mr. Leonard. Mr. Carter, at Newark, N. J., sells spoke machines. The way to estimate the power of your engine is to multiply the pressure of the steam into the square inches of the piston, that by the number of feet the piston travels per minute, and divide by 33,000 for the horse-powers, allow 20 per cent. for friction and loss. This is easy.

E. C., of N. Y.—During the progress of our next Volume we shall publish articles upon architecture, and illustrate the subject with numerous engravings of cottages and other buildings. It will be the most interesting volume we have ever issued, and we hope you may be able to send us an increased list of subscribers.

G. & Co., of Ala.—In consequence of the absence of one of this firm, who attended to your business, we have been unable to reply to yours of the 3d inst. You may expect an answer in a few days.

J. F. K., of Vt.—You could not obtain a patent for the idea you suggest about the brazing: ideas are not patentable. There is nothing patentable in the method, and we advise you not to make application.

A. J., of Miss.—We have examined the subject you brought to our notice and find it a complete tissue of false reasoning. We cannot publish the article without exposing the errors into which the writer has fallen, and think, on the whole, that we will not do so, as there are very few of our readers who care anything about the subject.

J. C. A., of Va.—We mean to write you in full in a few days about the boiler.

J. Y. P., of Ohio.—The friction on the two journals would be no serious objection. You are right about the speed improvement, it makes better flour. We are very favorably impressed with the improvement: such coincidences in invention are not uncommon. We believe it would be well for you to go on and make trial of the improvement.

H. A. S., of Vt.—Yours will be attended to next week.

A., of Boston.—We are obliged to you for sending us the extract. We have received a great number of singular papers on the same subject. Yours is the first which takes cognizance of the three forces. A number of careful and long-maintained experiments are still wanting to clear up the whole matter fully.

T. H. D., of N. H.; E. G. B., of Me.; H. C. B., of O.; R. R. F., of N. Y.; R. M. W., of Va.; T. D., of S. C.; G. W. L., of N. Y., and J. W. O., of O.—the engravings of your inventions are all executed, and will appear in our columns in their order.

Money received on account of Patent Office business since June 17:

J. L. H., of N. Y., \$30; L. L., of Mass., \$20; A. B., of Mass., \$30; L. & E., of N. Y., \$30; R. M. W., of Va., \$50; W. B., of Ala., \$10; M. P., of N. Y., \$30; C. L., of B., \$30; N. S., of N. Y., \$30; T. B., of N. Y., \$10; J. R., of N. Y., \$30.

Specifications and drawings of inventions belonging to parties with the following initials, have been forwarded to the Patent Office since June 17:

E. G. B., of Me.; A. B., of Mass.; L. L., of Mass.; G. W. P., of Ct.; G. R. W., of Ct.; J. R., of N. Y.; O. S., of N. Y.; R. M. W., of Va. (2), and W. B., of Ala.

Post Office Stamps.

In consequence of the change of rates on the first of next month, we would respectfully notify the public that henceforth, until further notice, Post Office Stamps will not be received at this office in payment for subscriptions to the Scientific American.

ADVERTISEMENTS.

Terms of Advertising:

One square of 8 lines, 50 cents for each insertion. " 12 lines, 75 cts., " " " 16 lines, \$1.00 " " "

Advertisements should not exceed 16 lines, and cuts cannot be inserted in connection with them at any price.

American and Foreign Patent Agency.

IMPORTANT TO INVENTORS.—The undersigned having for several years been extensively engaged in procuring Letters Patent for new mechanical and chemical inventions, offer their services to inventors upon most reasonable terms. All business entrusted to their charge is strictly confidential. Private consultations are held with inventors at their office from 9 A. M., until 4 P. M. Inventors, however, need not incur the expense of attending in person, as the preliminary can be arranged by letter. Models can be sent with safety by express or any other convenient medium. They should not be over 1 foot square in size, if possible.

Having Agents located in the chief cities of Europe, our facilities for obtaining Foreign Patents are unequalled. This branch of our business receives the especial attention of one of the members of the firm, who is prepared to advise with inventors and manufacturers at all times, relating to Foreign Patents. In the item of charges alone, parties having business to transact abroad, will find it for their interest to consult with us, in preference to any other concern. MUNN & CO., Scientific American Office, 128 Fulton street, New York.

15 HORSE-POWER ENGINE & BOILER

or for \$1000.—We have for sale a first rate Engine and boiler, built by Stillman, Allen & Co., of the Novelty Works, which will be sold at about half its original cost. The boiler is 20 feet long and 35 in. in diameter; 2 return flues, 11 in. in diameter each, with steam chamber top of boiler 2 ft. high, by 16 in. diameter. The heads are wrought iron, with grate bars, fronts, binders, and bolts complete, all made in the best manner, and called by the manufacturers a 20-horse-power boiler; also sheet-iron cap to conduct the smoke from the end of the boiler to the chimney. The Engine is upon a solid horizontal cast-iron frame 13 1/2 ft. long, 2 1/2 ft. in. deep; has a belt balance wheel 8 ft. diameter, 12 in. face; cylinder 2 1/2 ft. stroke and 8 3/4 in. diameter; has copper connecting pipes and heater for heating water before entering boiler; it has double pumps, and the whole is so complete and in such condition that no expense need be incurred in putting it in running order after being properly set. The Engine and Boiler have been in use but 3 years, and are offered at the low price of \$1,000 to close a concern. Any one wishing an engine and boiler of the above capacity, will find this an opportunity to purchase cheap which does not often occur. Any of our subscribers remitting a draft on New York for \$1,000, will receive in exchange therefor an engine and boiler which would not be furnished by a manufacturer for less than \$1,600. Address MUNN & CO., (Post-Paid.)

MECHANICAL DRAWINGS.—The subscriber, having returned to the city, will resume his business as Mechanical Draughtsman and Agent for the sale of Patents. Residence West Fifteenth St., first house east of Sixth av. J. H. BAILEY. 41 2*

NOTICE IS HEREBY GIVEN.—That letters of attorney, given to A. N. Cole to sell H. C. Brown's improved Sash Balance, have been duly revoked, countermanded, and made void, from the 12th inst., and recorded at Washington City. All persons having bought rights of said A. N. Cole, are notified to give immediate information of what portion of territory they have bought, or it will be sold again. Address H. C. BROWN, care of Munn & Co., No. 128 Fulton st., N. Y. 1*

THE COTTON CULTIVATOR. Patented March 20, 1849, is in successful operation in Maury Co., Tenn., both in the cultivation of corn and cotton; it is a saving of one-third the labor usually taken in the cultivation of the above named crops.—State, county, or plantation rights for sale: those wishing to buy will do well to come and see those who use them, and if they do not find them recommended by good farmers as here stated, I will bind myself to give them the right to any State or county. The farmers, in some places, have clubbed together and bought their counties, and have made money by it. The patentee, or some of his agents, will attend most of the Fairs this season, where the Cultivator may be seen. SAMUEL W. AKIN. 41 5*

CLOCKS FOR CHURCHES, PUBLIC Buildings, Railroad Stations, &c.—The undersigned having succeeded in counteracting, effectually, the influence of the changes of temperature upon the pendulum, and introduced a new regulator, by which great accuracy of time is produced, also the retaining power (which keeps the clock going while being wound) are prepared to furnish Clocks superior to any made in the United States. Ample opportunity will be afforded to test their performance, and those not proving satisfactory, when completed may be rejected. Astronomical Clocks made and warranted equal to any imported. Glass (Illuminated) Dials of the most beautiful description furnished. Address SHERRY & BYRAM, Oakland Works, Sag Harbor, L. I.

"Mr. Byram has established his reputation as one of the first clock makers in the world" [Scientific American.] "Mr. Byram is a rare mechanical genius" [Journal of Com. 29 1200w]

PALMER'S ARTIFICIAL LEGS.—Manufactured at Springfield, Mass., and 378 Chestnut at Philadelphia, by Messrs. Palmer & Co.—All orders from New York and New England must be made to Palmer & Co., Springfield, Mass.—"I have examined carefully the Artificial Leg, invented by Mr. B. F. Palmer; its construction is simple and its execution beautiful, and what is most important, those who have the misfortune to require a substitute for a natural limb, and the good fortune to use it, all concur in bearing practical testimony to its superiority in comfort and utility. VALENTINE MOTT. New York, Jan. 29, 51." 39 6meow*

MECHANICS' FAIR.—The Middlesex Mechanic's Association will open their first exhibition for the encouragement of the mechanic arts and manufactures in the city of Lowell, on Tuesday, Sept. 16, 1851. The Committee of Arrangements for this proposed Fair, respectfully invite and solicit all persons engaged in the various branches of mechanism, manufactures, science, and art, to present specimens of their various products for exhibition and premium. Ladies are cordially invited to present specimens of their ingenuity and taste. Premiums will be awarded to the articles presented may merit. Articles for exhibition should be sent on or before Sept. 10th. For more particular information or copies of the circular, address (post-paid) J. A. Beard, Esq., Supt., Lowell, Mass. By order, OLIVER M. WHIPPLE, Chairman. M. C. BRYANT, Sec'y. 40 10

SCHOOL FOR ENGINEERING, 650 Houston st., N. Y.—Mr. VICTOR BEAUMONT, Civil Engineer, graduate from "L'Ecole Centrale des Arts et Manufactures," of Paris, is about opening a new course of lessons in the French and English languages, in all the branches, theoretical and practical, connected with Civil Engineering. For details and references apply at the School. 38 4*

LAW'S PLANER FOR PLANK, BOARDS, &c., is now attracting much attention on account of its effectiveness, the excellence of its work, its simplicity, and consequent economy. Machines are now in operation in Brooklyn, New York City, and at various points South and West. Rights of machines for sale by H. LAW, 23 Park Row. 35 1f

IRON FOUNDERS MATERIALS—viz., fine ground and Bolted Black Lead, Soapstone, Lehigh Charcoal, and Sea Coal Firing Dusts. Iron and brass moulders' Sand, Fire Clay, Fire Sand, and Kaolin in barrels; also best Scotch Fire Bricks, plain, cupola, and side arch shaped, for sale by G. O. ROBERTSON, Liberty Place, (between 57 and 59 Liberty st., N. Y. 36 6*

LEONARD'S MACHINERY DEPOT, 109 Pearl st. 60 Beaver, N. Y.—The subscriber is constantly receiving, and offers for sale, a great variety of articles connected with the mechanical and manufacturing interest, viz., Machinists' Tools—engines and hand lathes, iron planing and vertical drilling machines, cutting engines, slotting machines, bolt cutters, slide rests, universal chucks, &c. Carpenters' Tools—mortising and tenoning machines, wood planing machines, &c. Steam Engines and Boilers, from 5 to 100 horse power. Mill Gearing, wrought iron shafting, brass and iron castings in order. Cotton and Woolen Machinery furnished from the best makers. Cotton Gins, hand and power, and power presses. Leather Banding of all widths, made in a superior manner, from the best oak tanned leather. Manufacturers' Findings of every description—bobbins, reeds, shuttles, temples, pickers, card clothing, roller cloth, potato and wheat starch, oils, &c. P. A. LEONARD. 33 1f.

PATENT CAR AXLE LATHE.—I am now manufacturing and have for sale the above lathes: they will turn and finish six sets per day, weight 5,000 lbs., price \$600. I have also for sale my Patent Engine Screw Lathe, for turning and chucking tapers, cutting screws, and all kinds of common job work; weight 1500 lbs., price \$225, if the above lathes do not give good satisfaction, the money will be refunded on the return of the lathe, if within six months. J. D. WHITE, Hartford, Conn. 32 13*

WOODWORTH'S PLANING MACHINE.—For sale, the right to use this justly celebrated labor-saving machine in the following States, viz.: Pennsylvania west of the Allegheny Mountains, Virginia west of the Blue Ridge, Ohio, Indiana, Kentucky, Tennessee, Wisconsin, Iowa, Missouri, Arkansas, Texas, Louisiana, Florida, Alabama, and Mississippi. For particulars apply to the Proprietor, ELISHA BLOOMER, 304 Broadway. 38 10*

GREAT REDUCTION IN PRICE.—The most valuable book of the day, containing domestic and medical recipes, rules with regard to the recovery and preservation of health, an account of the different medical theories of the day, useful tables, &c., entitled "THE GRAEFENBERG MANUAL OF HEALTH." It is complete in one volume of seven parts, and is beautifully printed upon fine paper, in a convenient form of 300 pages. The immense success which has attended the sale of previous editions, has warranted a reduction in the price of this (the 7th) edition, from 50 to 25 cts. per copy. Any number of copies, from one upward, will be forwarded upon the receipt of the money (post-paid). Address: THE GRAEFENBERG COMPANY, 214 Broadway, N. Y., or this Office. 38 1f

DR. S. B. SMITH'S TORPEDO ELECTRO Magnetic Machines.—These machines differ from all other electro-magnetic machines. The inventor has made an improvement by which the primary and secondary currents are united. The cures performed by this instrument now are, in some instances, almost incredible. For proof of this I refer to my new work lately issued from the press, under the title of "The Medical Application of Electro Magnetism." Mail edition, 25 cents. Postage, 6 cents. The Torpedo Magnetic Machines are put up in neat rosewood cases of a very portable size. Price, \$12. To agents they are put at \$9. Postmasters, druggists, storekeepers, and all who are willing to be instrumental in relieving the sick, are respectfully invited to act as agents. Address Dr. S. B. SMITH 297 1-2 Broadway, N. Y., or MUNN & CO., 128 Fulton st., N. Y. Can be sent by Express to all parts of the Union. 39 4*

SCRANTON & PARSHLEY, Tool Builders, New Haven, Conn., having had many applications for castings from their lathe patterns, with beds planed and screw and gearing cut, have now made arrangements to accommodate that class of customers; this arrangement will enable small shops, with a little more than half of the amount of ready cash, to get them a new lathe. Cuts of these lathes and other tools can be had by addressing as above (post-paid). N. B. Machinists' tools constantly on hand. 40 1f

WOODWORTH'S PATENT PLANING MACHINES: 1851 TO 1856.—For rights at Honesdale, Carbondale, Providence, Pittston, Scranton, Wilkesbarre, Williamsport, Meadville, Newcasttle, and other unoccupied towns in Northern Pennsylvania and New York, apply to JOHN GIBSON, Planing Mills, Albany, N. Y. 41 4*

CHILD'S PREMIUM SAW MILL.—To Plank Road Contractors and Lumbermen generally.—The subscriber having obtained a patent for improvements in circular saw mills, by which large timber can be cut with as great facility as small, and with one half less power, and one-third less waste of timber than by ordinary mills, offers mills and rights on reasonable terms. For illustration see Scientific American of March 15th, 1851. O. C. CHILD. Granville, Ill., May, 28, 2851. 39 9eow*

A CARD.—The undersigned beg leave to draw the attention of architects, engineers, machinists, opticians, watchmakers, jewellers, and manufacturers of all kinds of instruments, to his new and extensive assortment of fine English (Stubs) and Swiss Files and Tools, also his imported and own manufactured Mathematical Drawing Instruments of Swiss and English style, which he offers at very reasonable prices. Orders for any kind of instruments will be promptly executed by F. A. SIBENMANN, Importer of Watchmakers' and Jewellers' Files and Tools, and manufacturer of Mathematical Instruments, 154 Fulton st. 29 6m*

DICK'S GREAT POWER PRESS.—The public are hereby informed that the Matteawan Company, having entered into an arrangement with the Patentee for the manufacture of the so-called Dick's Anti-Friction Press, are now prepared to execute orders for the following, to which this power is applicable, viz.—Boiler Punches, Boiler Plate Shears, Saw Gummers, all Straighteners, Copying and Sealing Presses, Book and Paper Presses, Embossing Presses, Presses for Baling Cotton and Woolen Goods—Cotton, Hay, Tobacco, and Cider Presses; Flaxseed, Lard, and Sperm Oil Presses; Stump Extractors, &c. &c. The convenience and celerity with which this machine can be operated, is such that on an average, not more than one-fourth the time will be required to do the same work with the same force required by any other machine. WILLIAM B. LEONARD, Agent. No. 66 Beaver st., New York City. 25 1f

MACHINES FOR CUTTING SHINGLES.—The extraordinary success of Wood's Patent Shingle Machine, under every circumstance where it has been tried, fully establishes its superiority over any other machine for the purpose ever yet offered to the public. It received the first premium at the last Fair of the American Institute—where its operation was witnessed by hundreds. A few State rights remain unsold. Patented January 8th, 1850.—13 years more to run. Terms made easy to the purchaser. Address, (post-paid) JAMES D. JOHNSON, Redding Ridge, Conn., or Wm. WOOD, Westport, Conn. All letters will be promptly attended to. 37 1f

TO PAINTERS AND OTHERS.—American Anatomic Drier, Electro Chemical graining colors, Electro Negative gold size, and Chemical Oil Stove Polish. The Drier, improved in quality, by age—is adapted to all kinds of paints, and also to Printers' inks and colors. The above articles are compounded upon known chemical laws, and are submitted to the public without further comment. Manufactured and sold wholesale and retail at 114 John st., New York, and Flushing, L. I., N. Y., by QUARTERMAN & SON, Painters and Chemists 35 1f

MACHINERY.—S. C. HILLS, No. 12 Platt Street, N. Y., dealer in Steam Engines, Boilers, Iron Planers, Lathes, Universal Chucks, Drills, Kases, Von Schmidt's, and other Pumps, Johnson's Shingle machines, Woodworth's, Daniel's, and Law's Planing machines, Dick's Presses, Punches, and Shears; Mortice and Tenoning Machines, Belting machinery, &c.; Best's patent Cob and Corn Mills; Burr Mill, and Grindstones, Lead and Iron Pipe, &c. Letters to be noticed must be post paid. 38 1f

BAILEY'S SELF-CENTERING LATHE.—For turning Broom and other handles, swelled work, chair spindles, &c.; warranted to turn out twice the work of any other lathe known—doing in a first rate manner 2000 broom handles and 4000 chair spindles per day, and other work in proportion. Orders, post-paid, may be forwarded to L. A. SPALDING, Lockport, N. Y. 21 1f

RAILROAD CAR MANUFACTORY.—TRACY & FALES, Grove Works, Hartford, Conn. Passage, Freight and all other descriptions of Railroad Cars, as well as Locomotive Tenders, made to order promptly. The above is the largest Car Factory in the Union. In quality of material and in workmanship, beauty and good taste, as well as strength and durability, we are determined our work shall be unsurpassed. JOHN R. TRACY, THOMAS J. FALES. 39 1f

LAP-WELDED WROUGHT IRON TUBES for Tubular Boilers, from 1 1/4 to 7 inches in diameter. The only Tubes of the same quality and manufacture as those so extensively used in England, Scotland, France and Germany, for Locomotive, Marine, and other Steam Engine Boilers. THOS. PROSSER & SON, Patentees, 16 1f 28 Platt st., New York.

LATHES FOR BROOM HANDLES, &c. We continue to sell Alcott's Concentric Lathe, which is adapted to turning Windsor Chair Legs, Pillars, Rods and Rounds; Hoe Handles, Fork Handles, and Broom Handles. This Lathe is capable of turning under two inches diameter, with only the trouble of changing the dies and pattern to the size required. It will turn smooth over swells or depressions of 3-4 to the inch, and work as smoothly as on a straight line, and does excellent work. Sold without frames for the low price of \$25—boxed and shipped, with directions for setting up. Address, (post paid) MUNN & CO., At this Office.

STEAM ENGINES AND BOILER.—Several Steam Engines, now finishing, from five to fourteen horse-power; also one of 15 and one of 25. Having just enlarged my manufactory, I am now prepared to make all sorts, from 2 to 50 horse-power, of the best materials in all their parts. One second-hand engine of 8 horse-power, two cylinders, in good order, for sale, with new boiler, \$575. Also Galvanized Chain for chain-pumps. AARON KILBORN. No. 4 Howard st., New Haven, Conn. 32 1*

COTTON MACHINERY FOR SALE.—Viz., 4 Filling Frames, almost new; 1-16 Strand Speeder; 1 Warper; 1 Sapper; 2 Wind-mill Fans; 1 Reel; 1 Yarn Bundling Press; 1 Band Machine, and a large lot of tin cans. Apply to ELI WHITNEY, New Haven, Ct. 37 6*

WATTS & BELCHER, Manufacturers of Steam Engines, Lathes, Planing Machines, Power Presses, and Mechanics' Tools of all descriptions: Washington Factory, Newark, N. J. 38 13*

MECHANICS' INSTITUTE FAIR.—The attention of Mechanics, inventors, and artisans is especially called to the Polytechnic Exhibition, which will open at the rooms, cor. Bowery and Division st., on the 15th of May. Those who wish to exhibit models, machinery, &c., of mechanical skill, and those who would like to carry on, permanently, any mechanical occupation that would be in any way curious or attractive to visitors, are requested to call on the Actuary. Steam power will be provided. Well-lighted, warmed, and airy rooms can be had on liberal terms. As this Exhibition is permanent, an excellent opportunity is offered to skillful mechanics to bring themselves into notice. Articles may be sent in immediately and will be taken care of and insured. Z. PRATT, Pres.; T. C. DODD, Actuary. 34 1f

Scientific Museum.

For the Scientific American.
Floating of Rafts on Rivers.

I was pleased to see a communication in your paper from an inquisitive correspondent at Silver Creek, signed "A. R.," concerning the floating of rafts. Permit me, in alluding to it, to lay down a principle, now mentioned publicly, I believe for the first time. It is the analogy of a current of water to an inclined plane. I tracing this connection I think A. R. can run his opponents aground, and account satisfactorily for all the cases he advances in demurrer to their solution. Let a raft be ever so large and lying still in dead water, a pull of 10 lbs. on a rope attached will start it; or 5 lbs., or even 1 lb., very slowly, granted, but it overcomes the friction of the water so as to move the raft. Now the fall between Olean Point and Pittsburgh is perhaps a foot and a half to the mile, or more. Consider how readily heavy cars run down a very small incline, and one sees that the log or raft would start down stream, even supposing the water standing still on that inclination. But let the raft be cut loose in the running water, and what happens? As you remarked last week, the heavier water impinging behind the raft, gradually increases its velocity until it shall have a velocity equal to the water, and they move on together—water and raft: and so they would continue to go down the incline faster and faster together, only the friction of the banks and bottom impedes the water, while the friction of the water on the raft is not so great as the earth on the water, and the raft is not hindered so much in its downward course on this inclined plane. The water thus gives to the raft its own velocity, and a man on the raft would seem to have still dead water around him. But it is on the inclined plane, nevertheless, and as it would start downward, as in my first supposition, so it will start ahead of the water around it now. Thus it out-runs the current—thus the longer, larger, more compact or smoother it is, the less the water catches it and keeps it from sliding down; as the larger the boat the less her water surface in proportion to tonnage.

This accounts for the fact long known by military men, viz., that a river may be crossed by surprise, by directing the boat with the rudder downward and a little across the stream.

My attention was called to the subject of the currents of our western rivers by a conversation with Col. Long of the U. S. Topographical Engineers some years ago, and since that I have thought much on the subject. Had we the data which A. R. has given the public, we might have shortened the discussion of a question of considerable interest at the time.

I could wish that there were more intelligent and inquisitive observers of nature like him, every where, than there are. J. C. S.

West Troy, June, 1851.

Horse Shoeing.

The shoes of the horse should be of equal thickness throughout, with a flat ground surface, as those with high heels which assinine smiths make in imitation of their own are dangerously absurd. The toe, which ought to be raised is lowered and nature's plan reversed, which elevates the point in order to avoid obstructions. The web should be wide and of the same width throughout, instead of being pinched in because the smith likes to see the shoe well set off at the heels. This is both unphilosophical and detrimental; it deceives the eye of man and injures the foot of the horse. The outer edge of the foot rests on the inner edge of the shoe, and the remaining width of the web projects beyond the hoof; so that the master who thinks his horse has a good open foot, only has to be proud of a bad open shoe, which both conceals deformities underneath, and invites with open arms a bad road to come and do its worst. The heels are made bare just where the navicular joint is most exposed; and if that be inflamed, what must the agony be when the unprotected foot treads on a sharp flint? The horse falls suddenly lame, or drops as if he had been shot—phrases in much too common use to require

explanation; and small is the pity which the suffering animal meets with from man, who, having first destroyed the use of his victim's feet, abuses him because he cannot go; and imputes "grogginess" to him as crime, as if he were in liquor like a groom, and not in agony.

The above remarks are from the pen of Mr. Miles, Veterinary Surgeon of the English Life Guards.

For the Scientific American.
Hydraulics.
(Continued from page 320)

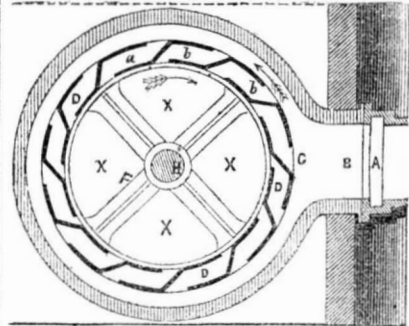

GWYNNE'S WATER WHEEL.—This engraving, fig. 55, is a sectional elevation of a water wheel, recently patented in England, and termed "Gwynne's Patent Double Acting Balance Pressure Wheel." A swelling name truly.

A is the sluice, B the water way communicating with the annular space, C, around the wheel; D D are the buckets; F represents the arms, and H the shaft. The London Mechanics' Magazine, speaking of its merits, says: "The peculiar features of this wheel, and the principal improvements from any other of its class, consists in the shape of the partitions between each water way, presenting a direct surface to be acted upon by the water in its passage through the wheel, whether the water passes into the dam through the wheel or from the dam to the river. The annular space, a, a, which contains the partitions or buckets, b, b, is cased at the top and bottom, as represented, both surfaces of which are turned perfectly true in the lathe; these surfaces work upon the lower, under, and upper surface of the annular casing at d, d, but not in such contact as to cause much friction, thereby directing the water through the water-ways between each partition. The advantage of this form of bucket partition is, that it presents a more direct and greater area of surface to the action of the water in its passage through the wheel, whether the water be going into or out of the dam. The direction in which the wheel moves is shown by the arrows in the plan."

It will be observed by the arrows, the motion of this wheel is contrary to that of the water, it therefore must be less effective than our re-action wheels, the great improvement in them being the motion of the water coinciding with that of the wheel, yet while the overshot water wheels set down at 70 per cent. power, Mr. Gwynne modestly claims 85 per cent. for this one. The zig zag buckets are not new in principle by any means, but they are not adopted in this country because of defects in the principles of the water action. The angular direction of the water is much better carried out in the S bucket wheel of Whitelaw & Stirratt, and the curved bucket of all the American wheels—turbine-shape is more scientifically adapted for water wheels, than Gwynne's sharp angled double acting pressure wheel.

A New Remedy for the Scurvy.

The surgeon general of the army publishes the substance of an official report by Assistant Surgeon Glover Perin, United States Army, stating that the Maguey or *Agave Americana* is a very efficacious remedy in scurvy. Mr. Perin has used it in Texas, and in every case with marked improvement over those cases in which lime-juice and other anti-scorbutics were used.

"The juice of the Maguey contains a large amount of vegetable and saccharine matter, and of itself is sufficiently nutritious to sustain a patient for days.

This excellent plant grows indigenous in most parts of Texas, and, if I am correctly informed, in New Mexico and California. In

Mexico it is well known as the plant from which they manufacture the "Pulque," and grows in great abundance. As it delights in a dry sandy soil, it can be cultivated where nothing but cacti will grow; for this reason it will be found invaluable to the army at many of the western posts where vegetables cannot be procured.

The manner in which it is used as follows:—The leaves are cut off close to the root; they are placed in hot ashes until thoroughly cooked, when they are removed and the juice expressed from them. The expressed juice is then strained, and may be used thus, or may be sweetened. The dose is from two to eight ounces, three times daily. It is not disagreeable to take, and in every instance it has proved to agree well with the stomach and bowels. After the leaves have been cooked, the cortical portion near the root may be removed, and the white internal portion eaten. It appears to be a wholesome and nutritious food, and I have been informed upon good authority that several tribes of Indians in New Mexico make use of it in the same manner. The use of the leaf in this way, I believe, will ward off most effectually incipient scurvy."

Receipts For Cholera.

The worst cases of cholera morbus, dysentery, and flux, that ever I saw I have repeatedly cured in a few minutes, by a strong tea made of the bark of the Sweet Gum, taken green from the tree is best—steep a handful to a pint of water until the liquor is like good coffee. Drink it clear, or sweeten it with loaf sugar, or add a wine glass of good brandy if the shock is severe. If not infallible, it is remarkable in its effects, and well worth being known and tried in every family.

SOLIN ROBINSON.

We can add our own testimony to the value of the Sweet Gum tea, having experienced amazing and speedy relief from its use in a violent case of dysentery, which refused to yield to the usual remedies; we have also seen in the last five years, its wonderful benefit in many other cases; we have used decoction made from the bark both green and dried, and have discovered no material difference in the effect, both being efficacious.—[Franklin Farmer.

I met with the foregoing valuable receipt several years since, and I have only to add, what has already been said by the "Franklin Farmer"—that I have witnessed speedy relief in violent cases of dysentery which refused to yield to the usual remedies, by the use of the Sweet Gum; having it at command, I have used the fresh or green bark, and I can with much confidence recommend its use from my own experience. A GEORGIA PLANTER.

[It would appear that the cholera still lingers on the banks of our western waters, and in the level districts of the Southern States. In all likelihood it will never leave the South; it will visit many places periodically, as in the East Indies. In that case, it is best to be prepared to meet it at any moment, and the above receipts from the Charleston (S. C.) Mercury are the results of practical experience, and are worthy of confidence.

St. Domingo Antiquities.

Sir Robert Schomburg, British Consul at St. Domingo, has discovered some very interesting remains of the aborigines who formerly inhabited that island, among which there is a granite ring, 2,270 feet in circumference and 21 feet in breadth. In the middle of this circle lies an idol, nearly 6 feet in length, formed likewise out of granite. During all his travels in Guiana Sir Robert never met with such a monument, which bespeaks a much greater advancement than the races possess who at present inhabit that vast territory, or who inhabited the island of St. Domingo when Columbus landed there. Sir Robert made this discovery during one of the journeys which he has already undertaken, in order to make himself acquainted with the capabilities and population of the Dominican Republic. He is now preparing for a journey to the most interesting district of the Republic—the province of Cibao—comprising also the classical ground where Columbus landed.

A horse-shoe fish, well known on the sea-shore, has been found in Oswego harbor. No such fish was ever seen there before. It is supposed to be a native of salt-water, and to have found its way up the St. Lawrence from the ocean.

LITERARY NOTICES.

VESTIGES OF CIVILIZATION.—This is a new book, published by H. Bailliere, Broadway, N. Y.: its title indicates the intentions which the author, not we, can perceive in his book. Who the author is we do not know, but he seems to be well pleased with his work. We have read some books, from the perusal of which we have arisen much wiser but of this we can say "much duller." This may appear strange, as the author claims for this work a simplicity, clearness, and scientific arrangement surpassing all others. It is a hasty and obscure production; the style is not good. The author lays down a theory that the human mind is progressive, moving forward in cycles under the influence of his god, "Nature and Humanity." This is a miserable production in comparison with Douglas's work on the "Advancement of Civilization." To go through its pages is something like swallowing stones, a custom practised by the New Zealand mothers with their children, to give them hard and strong hearts.

MUSIC METHOD FOR THE PIANOFORTE.—A new work on pianoforte music, and instructions for the instrument, by Carl Czerny, has just been issued by the publisher, Oliver Ditson, Washington St., Boston. It is well known that Czerny's great work on the pianoforte is by far the best in the world; this work, published by Mr. Ditson, contains nearly all of the original work, faithfully preserving every feature. The fame of the author is world-wide, and this book, as an instructor, should be put into the hands of children as soon as they commence learning. It often happens, indeed it is a common opinion, that any cheap book is good enough to commence learning with: this is a great mistake, for errors acquired at the threshold of the art are more difficult to eradicate than to learn. We cannot too strongly recommend this excellent and standard work.

SHAKESPEARE'S POETICAL WORKS.—Published by Phillips, Sampson & Co.; Dewitt & Davenport, New York, agents. The publishers deem it advisable to issue the Poems in three large parts. The present number forms the first of this series. The next number will contain a magnificent vignette title page, now engraving from an original design by Billings. The third and concluding part will contain a splendid engraving of Mrs. Siddons as the Tragic Muse, from the celebrated painting by Sir Joshua Reynolds.

PETERSON'S LADIES' NATIONAL MAGAZINE, for July, is issued and for sale by Dewitt & Davenport, Tribune Buildings. It is a good number and has some illustrations.

WELL'S HARTFORD DIRECTORY.—We are indebted to J. Gaylord Wells, of Hartford, Conn., for a copy of their City Directory.

GRAHAM'S AMERICAN MAGAZINE, for July, is a beautiful number, containing 12 embellishments and a brilliant variety of reading matter. The engravings are finely done. This number commences Vol. 39. Terms \$3.

SARTAIN'S UNION MAGAZINE, for July, continues the "Scenes in the Life of Christ," presenting seven illustrations finely done on wood. Mr. Sartain gives a fine mezzotint of "Alone at the Rendezvous." The number throughout is good. \$3 per annum.

MECHANICS

INVENTORS
AND
MANUFACTURERS.

The Best Mechanical Paper
IN THE WORLD.
SIXTH VOLUME OF THE
SCIENTIFIC AMERICAN.

The Publishers of the SCIENTIFIC AMERICAN respectfully give notice that the SIXTH VOLUME of this valuable journal, commenced on the 21st of September last. The character of the SCIENTIFIC AMERICAN is too well known throughout the country to require a detailed account of the various subjects discussed through its columns.

It enjoys a more extensive and influential circulation than any other journal of its class in America.

It is published weekly, as heretofore, in *Quarterly Form*, on fine paper, affording, at the end of the year, an *ILLUSTRATED ENCYCLOPEDIA*, of over FOUR HUNDRED PAGES, with an Index, and from FIVE to SIX HUNDRED ORIGINAL ENGRAVINGS, described by letters of reference; besides a vast amount of practical information concerning the progress of SCIENTIFIC and MECHANICAL IMPROVEMENTS, CHEMISTRY, CIVIL ENGINEERING, MANUFACTURING in its various branches, ARCHITECTURE, MASONRY, BOTANY,—in short, it embraces the entire range of the Arts and Sciences.

It also possesses an original feature not found in any other weekly journal in the country, viz., an *Official List of PATENT CLAIMS*, prepared expressly for its columns at the Patent Office,—thus constituting it the "AMERICAN REPERTORY OF INVENTIONS."

TERMS—\$2 a year; \$1 for six months.

All Letters must be Post Paid and directed to
MUNN & CO.,
Publishers of the Scientific American,
128 Fulton street, New York.

INDUCEMENTS FOR CLUBBING.

Any person who will send us four subscribers for six months, at our regular rates, shall be entitled to one copy for the same length of time; or we will furnish—
10 copies for 6 mos., \$8 15 copies for 12 mos., \$22
10 " 12 " \$15 20 " 12 " \$26
Southern and Western Money taken at par for subscriptions.

PREMIUM.

Any person sending us three subscribers will be entitled to a copy of the "History of Propellers and Steam Navigation," re-published in book form—having first appeared in a series of articles published in the fifth Volume of the Scientific American. It is one of the most complete works upon the subject ever issued, and contains about ninety engravings—price 75 cents.