

II. *A Description of an Engine to raise Water by the Help of Quicksilver, invented by the late Mr. Joshua Haskins, and improv'd by J. T. Defagulier, LL. D. R. S. S.*

MR. *Haskins* finding that all Hydraulic Engines, working with Pumps, lose a great deal of Water, (always giving less than the Number of Strokes ought to give according to the Contents of the Barrels:) and that when the Pistons are new leather'd to prevent that Loss, the Friction is much increas'd. and the Engines are subject to Jerks, which in great Works do often disorder an Engine for a great while, by breaking some of the Parts; contriv'd a new way of raising Water without any Friction of Solids; making use of Quicksilver instead of Leather, to keep the Air or Water from slipping by the sides of the Pistons in the Barrels where they work; hoping thereby to prevent all the abovesaid Inconveniencies, and also to have Water Engines less liable to be out of Order than any yet made.

The first Experiment he made with an Engine that he set up at my House about two Years ago, which I repeated before the Royal Society in a Model; and tho', by the ill Contrivance of the Parts, it did not raise near the Quantity of Water that the Invention is capable of; yet I shall describe the Machine here, because it will serve for the better Understanding of our present Engine.

B

FIG.

FIG. I.

dddd represents a *Lignum Vitæ* Plug or Piston (which Mr. *Haskins* call'd a Plunger) about 6 Foot long made heavy enough with Lead at top to sink into *Mercury*, which is beforehand pour'd into the Barrel *D 1* *D 2* up to *mm*. The Chain *E 1* *E 2*, joyn'd to the Piston and the Power that moves it, being let down till the Piston comes to *D 2*, the *Mercury* rises to the same Height in the Barrel, and in the Receiver *R*, (which it fills) namely to *nn*, as appears in the Figure. Then drawing up the Piston till its Bottom is come to *mm*, the *Mercury* coming out of the Receiver down to *oo* makes a *Vacuum*, and the Weight of the Atmosphere causes the Water to rise up thro' the Sucking Pipe *A 1* *A 2*, and Valve *V* into the Receiver where the *Mercury* was before. Upon letting down the Piston again, the *Mercury* rises into the Receiver, and drives up the Water thro' the Elbow *B*, the forcing Valve *u*, and so up the forcing Pipe *a 2* *a 1*: But when once the forcing Pipe (which here was 46 Foot high) is full, before any *Mercury* can enter into the Receiver, and force any Water out at the top of the Pipe *a 1*, the *Mercury* between the Piston and Barrel must rise up to *qq* near $3\frac{1}{2}$ Feet above the Bottom of the Receiver, and as it continues to rise up to *pp*, the Water is thrown out with a Velocity proportionable to the Height that the *Mercury* is rais'd above the $\frac{1}{4}$ th part of the Height of the Water. Now tho' the Friction of Solids is here avoided, it is plain that the *Mercury* must move from *mm* to *qq* without raising any Water, and that it can only force in going from *qq* to *pp*, and only suck in falling from *oo* to *mm*: And unless the Piston is stopp'd a little

little while when at lowest, the Water won't have time to run out: So likewise the Piston must be stopp'd when at highest, that the Receiver may have time to fill.

Mr. *Haskins* likewise propos'd another Way, represented in *Fig. 2*; where the same Letters represent the same Parts, only here the Barrel is moveable by the two Chains *E 1 E 2*, and instead of a solid Piston, the hollow Cylinder *C 1 c c* is fix'd, and the *Mercury* moving up and down in the lower Part of it, sucks and forces the Water thro' the Elbow. The Figure represents the Engine sucking, by means of the *Mercury* hanging from *o o* to *m m*. In order to force, before any Water can be driven out, the *Mercury*, in the inner Cylinder must descend from *o o* to *m m*, and rise up to *pp* between that Cylinder and the Barrel; so that here also a great deal of time is lost; besides the great Quantity of *Mercury* us'd, which is very expensive; because as much *Mercury* is mov'd every Stroke as the Water rais'd.

These Difficulties very much puzzled Mr. *Haskins*, and quite discourag'd some other Persons that had got the Secret of the Invention, and were setting up against him. But when I had consider'd the Matter a little, tho' I had not time to contrive a Machine for it, I told him, That a little *Mercury* might be made to raise a great Quantity of Water, and there should not be such a loss of time as in his Engines; but that I would have him find it out before I assisted him farther. In a little time he found out the Contrivance represented in *Fig. 4*; and afterwards that of *Fig. 3*; which last was what I had thought of: And both these were also found out by the late Mr. *William Ureem*, who was an excellent Mechanick.

FIG. III.

Here the Barrel is mov'd as in *Fig. 2*, but the Plug *ddd* taking up a great deal of Space, there is Occasion for no more *Mercury* than what will make a concave Cylinder or Shell up to *pp* between the Barrel *D 1 D 2*, and the hanging Cylinder *C 1 C 2 cc*, when the Stroke is made for forcing; and a concave Cylinder between the Plug and *C 1 C 2 cc*, when the Suction is made. I gave Mr. *Haskins* the Proportions for an Engine this way, of which he made a Draught, and shew'd it to the Right Honourable the Lord Chancellor about six Months ago. This I mention here, that no body may endeavour to get a Patent for this Invention, to the Prejudice of Mr. *Haskins's* Assignees; who, since his Death, have desir'd me to assist them in perfecting the Engine.

FIG. IV.

Here the Barrel with a third Cylinder *dddd* instead of the Plug of *Fig. 3*, is lifted up and down every Stroke, and the Water pass'es thro' *dddd*, the *Mercury* making a Shell sometimes between the middle and inner Cylinder, as in the Suction; and sometimes between the Barrel and the middle Cylinder, as in the forcing Stroke.

Mr. *Haskins* had contriv'd such a Machine as is represented by this 4th Figure, and bespoke the several Parts before he dy'd; and therefore when I was desir'd by his Assignees to direct the setting up the Machine, I was oblig'd to make use of the Pieces already made, in order to save the Expence of a new Engine: And now the whole put together with some
Al-

Alterations, make the Engine represented by *Fig. 5*, as it is set up at my House in *Westminster*, and by the Force of one Man, raises a Hogshead of Water in little more than a Minute and a half to the Height of 27 Feet. All the Fault of the Machine of *Fig. 5* is, that the Pendulum Handle *Ff* is too long, and the Bottom of the middle Cylinder *C* ought to be just in the middle of the Height to which the Water is to be rais'd, supposing three Copper Cylinders to be as they are here: If likewise the Barrel *D 1 D 2* work'd under the forcing Pipe, the Lift would be easier. Therefore I describe the Machine with the small Alteration represented in *Fig. 6*.

The sucking and forcing Pipe and Valves are mark'd with the same Letters as in the other Figures; and the Chains *E 1 E 2* must be suppos'd to hang from such Pullies, and to be mov'd by such a Pendulum as is in *Fig. 5*. The Barrel *D 1 D 2* (call'd otherwise the outer Cylinder, and represented by the same Letters in *Fig. 7*.) has within it another Cylinder (call'd the inner Cylinder or Plug, as *dddd Fig. 7*.) between which two Cylinders a certain Quantity of *Mercury* is pour'd in, and the hanging Cylinder *C* coming down into the *Mercury*, a Stroke of 13 Inches may be made by the Motion of the Barrel, which, in going down sucks by making a *Vacuum* in *C*, and in going up forces the Water out of the top of the forcing Pipe, performing the Office of a common Piston; only that instead of Leather to make it tight to the Cylinder *C*, there is always a thin Shell of Quicksilver either between the middle Cylinder *C* and the inner one, (*dddd Fig. 7*.) as happens when the Suction is made, or between the middle and outer Cylinder, as happens in lifting up the Barrel to Force. In the Suction, the *Mercury* is higher in the
inner

inner Shell than in the outer Shell, by an Height equal to a little more than $\frac{1}{4}$ Part of the Height of the Barrel above the Water to be rais'd: And in forcing, it is higher in the outer Shell than in the inner by a little more than $\frac{1}{4}$ of the Height of the Pillar of Water to be forc'd. And therefore if the Water is not required to be rais'd above 64 Feet, the Barrel should move so as to make the Middle of its Stroke at the Height of 30 Feet, or at the middle of the way from the Water to be rais'd, to the Delivery at top.

The 7th Figure drawn by a larger Scale, represents the three Cylinders, which are here made of Copper in their just Proportions: And for the sake of those that would consider this matter fully, I have here given their Lengths, Diameters within and without, and Thickness.

	Outer Cylinder or Barrel, D ₁ D ₂ .	Middle or hang- ing Cylinder, in which the Stroke is made C ₁ C ₂ cc.	Inner Cylinder or plug clos'd at top by a Cap, and mo- ving up and down with the Barrel to which it is joyn'd at bottom. dddd.
	<i>Inches</i>	<i>Inches</i>	<i>Inches</i>
Length	————— 30	————— 29,0	————— 31,2
Diameter within.	} ————— 6,74	} ————— 6,35	} ————— 6,03
Thickness	} ————— 0,10	} ————— 0,08	} ————— 0,13
Diameter without	} ————— 6,94	} ————— 6,51	} ————— 6,29

Here BB represents part of the Elbow of *Fig. 5.* or of the forcing Pipe of *Fig. 6.* But as the Spaces between the Cylinders are so small, as not to be visible even in a large Draught made by a Scale; I have here given three more Draughts of the three
Cy-

Cylinders, where the Height is agreeable to the Scale of the 7th Figure, but the Diameters of the middle and inner Cylinders are made less than they are in the Engine, to make the Space between (where the *Mercury* rises and falls) visible; and the Cylinders themselves are represented by single Lines.

The Quantity of *Mercury* us'd in this Engine is $36\frac{1}{2}$ Pounds, which being pour'd in between the outer and inner Cylinder, rises up to the Height of 16 Inches.

When the Barrel is pull'd up (as in *Fig. 9.*) so as to have the middle Cylinder within an Inch of the Bottom of the Barrel; the *Mercury* on both sides the middle Cylinder will rise up to the Height of 23,1 Inches, that is about two Inches below the Cup D1, to the Line *q q.*

When the Barrel is going down to fill the sucking Pipe and middle Cylinder C, the *Mercury* in the inner Shell will be 25 Inches high, and only 13 in the outer Shell, *Fig. 9.*, where the shaded part represents the \varnothing .

At the End of the sucking Stroke the *Mercury* is up to the top of the inner Cylinder, and scarce an Inch in the outer Shell. *Fig. 8.*

In raising the Piston from forcing to Sucking, the first $1\frac{1}{2}$ Inch drives the *Mercury* out of the inner Shell, and raises it in the outer Shell 13,28 Inches.

The Depth of an Inch of Water in the middle Cylinder above the inner one or Plug is equal to a Space in the outer Shell of 13,28 Inches, and $\frac{1}{2}$ of an Inch is equal to the same Height in the inner shell.

Therefore when the *Mercury* is equally high in both Shells, a Motion of $\frac{1}{4}$ of an Inch of the Barrel will charge for Suction. That is, upon letting down the Barrel only $\frac{1}{4}$ of an Inch, the Pressure of the Atmosphere in the outer Shell will raise the *Mercury* in the inner one 13,28 Inches, at the same time

time, that it pushes up the Water from the Well 13 Foot and a half high into the sucking Pipe. And when all the Pipes are full, if the *Mercury* be equally high in both Shells, upon raising the Barrel one Inch, the *Mercury* will rise 13.28 Inches in the outer Shell; which I call charging for forcing; because in continuing to raise the Barrel, the forcing Valve immediately rises, and the Water comes out at top during the rest of the Stroke, which is 12 Inches, and delivers 1,6 Gallon of Water, Wine Measure.

Fig. 10. represents the forcing Stroke half way up; with the \varnothing 17 Inches in the outer Shell 4 Inches in the inner, and the whole space at bottom under the middle Cylinder 7 Inches.

From this it appears, that in the whole Stroke of 13 Inches in Length, there is only $\frac{1}{4}$ of an Inch lost to charge for Suction, and in the next stroke, which is likewise of 13 Inches there is only one Inch lost to charge for forcing; so that in a Motion of 26 Inches, there is but $1 \frac{1}{4}$ Inch, or about $\frac{1}{5\frac{1}{2}}$ part ineffectual. But this is owing to the too large space of the outer shell, which contains 4 times more than the inner one, because the Cylinders were only hammer'd, and not turn'd; for if the outer space had been no bigger than the inner; then $\frac{1}{4}$ of an Inch of the stroke would have charg'd for forcing; so that only $\frac{1}{5}$ an Inch in 26, or $\frac{1}{5\frac{1}{2}}$ part of the whole stroke would have been ineffectual; and in that Case, $\frac{2}{3}$ of the Quantity of *Mercury*, or a little more than 12 Pounds, would have been sufficient.

There may still less *Mercury* be us'd, if the middle Cylinder be made of Plate Iron turn'd on the outside, and bor'd within, the outer Cylinder bor'd, and the inner one turn'd; so that if the Work be well perform'd, eight or ten Pounds of *Mercury* will
be

be sufficient in this Engine, tho' the Bore of the middle Cylinder, or Diameter of the Pillar of Water which is rais'd, be of 6,35 Inches. If the Bore of the said Cylinder was but 3 Inches, less than 3 Pounds of Mercury would suffice, and less than six if there were two Barrels, in order to keep a constant stream thro' a Pipe of almost the same Diameter. This will very much lessen the Expence of Mercury, which would otherwise be an Objection against this Engine; and by making the inner and outer Cylinder of hard Wood, as *Box*, or *Lignum Vita*, the Cost of the Engine may still be reduc'd. But if the Engine be very large, Cast Iron bor'd will be proper for the outer Cylinder, and Cast Iron turn'd on the outside for the inner Cylinder or Plug, and hammer'd Iron bor'd and turn'd for the middle Cylinder.

There is an Objection, which seems at first to take off the intended Advantage of this Engine, which is this, *viz.* That instead of the Friction of the Leather of a Piston, when we lift up our Barrel to force, the Resistance, that the *Mercury* finds to rise in the outer Shell, is at least as great as the Friction that we avoid. Now that Resistance is never greater than the Weight of a concave Cylinder of *Mercury*, whose Height is the greatest to which the *Mercury* rises in the said Shell, and the Base is the Area of the Shell it self. This Weight in our Engine is equal to 57,5 Pounds, and therefore one would think it greater than the Resistance made by the Friction of a Piston. But if it be consider'd, that in the Descent of the Barrel for sucking, the *Mercury* shifts immediately into the inner Shell, rising to the same Height, and still keeping the same Base; the aforesaid Weight of 57,5 Pounds helps down the Barrel, and facilitates the overcoming of the Force of the Atmosphere, consequently the

Weight of the *Mercury* being balanc'd, is no Hindrance, whether you work with a single or a double Barrel.

There remains only then the Hindrance by lots of time in the Beginning of any Stroke: But I have shew'd that to be but $\frac{1}{3}$ part of the stroke. I have found that the best Engines now in use generally lose near $\frac{1}{3}$ of the Water that they ought to give, according to their Number of Strokes. And Mr. *Henry Beighton*, an ingenious Member of this Society, having a great many times measur'd the Water that is rais'd by Engines in Mines, found that some Engines lost $\frac{1}{3}$, and none ever lost less than $\frac{1}{3}$ of what they ought to give according to the Number of the Strokes in their Pumps, whatever auxiliary Powers they were mov'd with.

There is indeed another Objection, but scarce worth notice; which is, that some Particles of *Mercury* will mix with the Water that is rais'd, and make it unwholesome; but no body that considers Specifick Gravity, will imagine any such thing. However, to satisfy those that might still apprehend it, it is to be observ'd, that none of the Water that is rais'd comes near the *Mercury*: For in the Cylinder C, and part of the Elbow B, (*Fig. 5.*) there is always above the *Mercury* a certain Quantity of Water that rises and falls with the Barrel, and never goes into the forcing Pipe. The same happens also in the Machine of *Fig. 6.* for the Water having once run into the Cylinder C, all that is rais'd afterwards, comes thro' the forcing Valve without coming down to the *Mercury*.

Provided Care be taken to make the Barrel with its Plug tight, I don't see that this Machine will want Repair in a long time, except some of the auxiliary Powers be out of order, which do not relate to
this

this Invention. The Numbers given will serve to examine the Truth of what I have asserted concerning the Motion of the Mercury: And from them one may make Tables to serve to proportion these Engines for raising any Quantity of Water to any Height, according to the Power one has to apply.

III. *Part of a Letter from Mr. Peter Derante, Chirurgeon in Waterford, to Mr. John Douglas, Chirurgeon, F. R. S concerning the coming off of the Scapula and Head of the Os Humeri, upon a Mortification.*

ON the 5th of November, 1713, One John Fletcher, on board the *Neptune* of *Liverpool*, had the Misfortune to break the *Radius* and *Ulna* (of his left Arm) and their Ends burst thro' the Skin. He was immediately dress'd by the Surgeon of the Ship with the common Astringents and Bandage; about five or six Days afterwards I was sent for to go down to *Passage* to see this Man. When I came there, I found his Surgeon along with him, who told me, That the Man would do very well, because he was in no pain at all; however, I desir'd him to take off the Dressings, and let me look on't. Which being done, I found it was black and insensible from his Fingers to his Shoulder, and therefore advis'd the Extirpation of it immediately, but his Surgeon oppos'd it; however, I scarified it in several Places, and very deep, and then apply'd a warm Dressing. Next Day the Ship put to Sea, and the poor

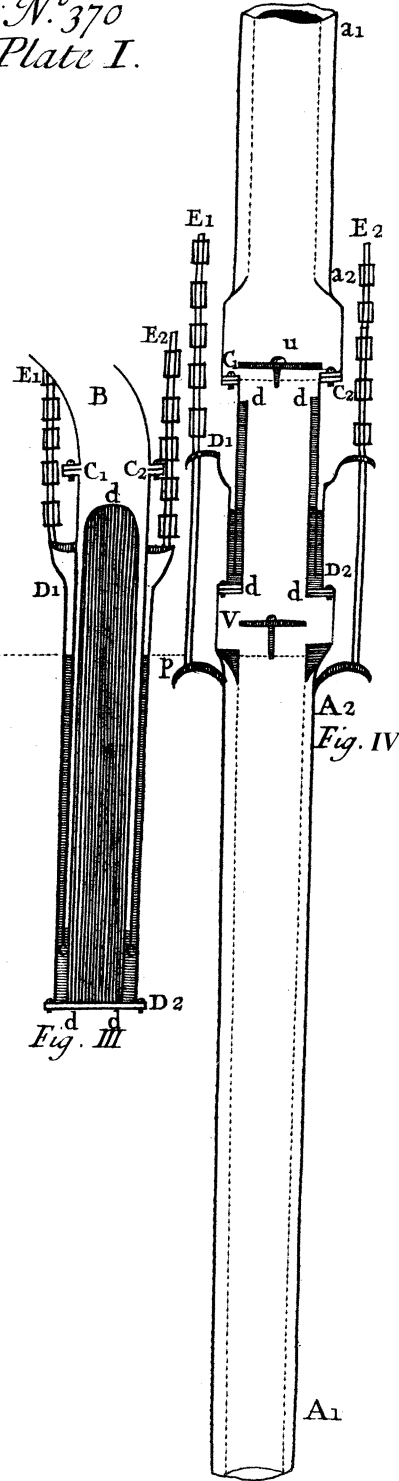
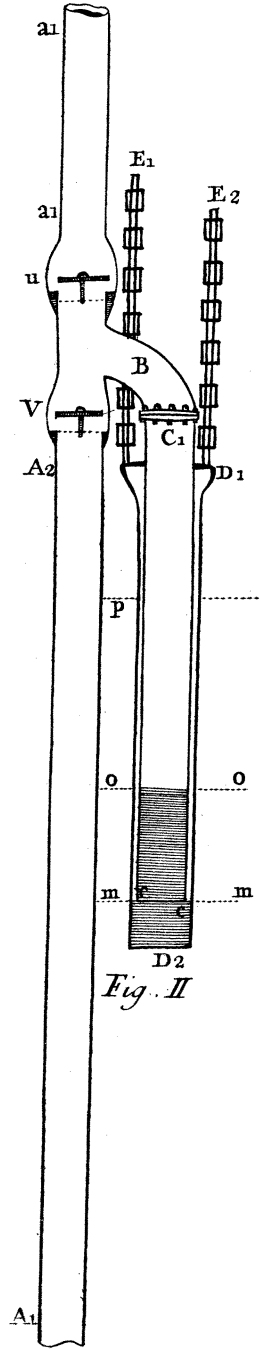
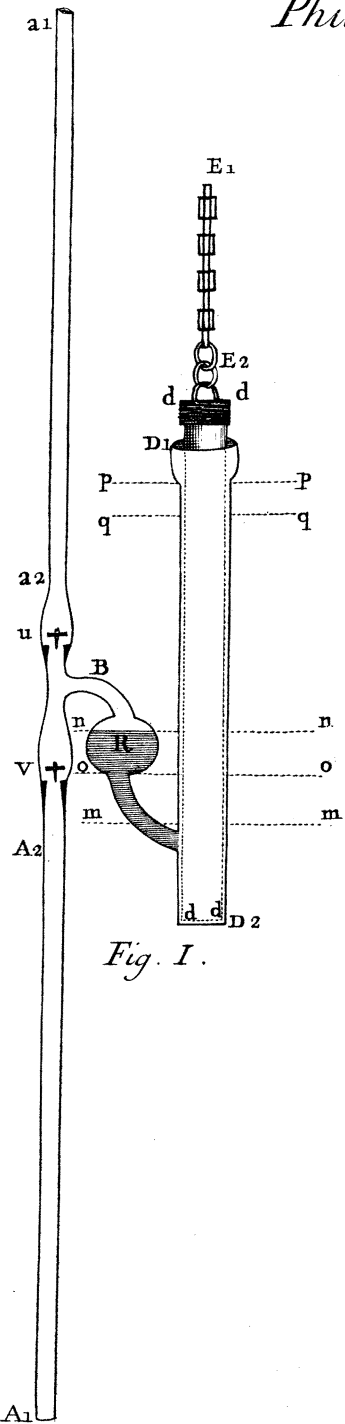

	<i>Inner Cylinder.</i> <small>feet Inch^s tenths</small>	<i>2^d or Mid. Cylinder.</i> <small>f. i. t.</small>	<i>Out³ Cylinder</i> <small>f. i.</small>
<i>Length</i>	2.7.2	2 5.0	2.6
<i>Diameter within</i>	0.6.03	6.35	
<i>Thickness</i>	0.13	0.08	
<i>Distance between Outer & Inner Cylinder</i> 0.225			

*Depth of to
Diamete
Length of
Stroke in y*

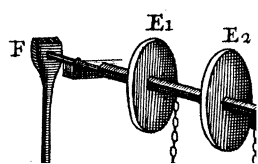
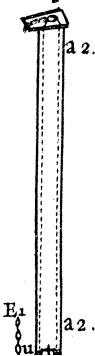
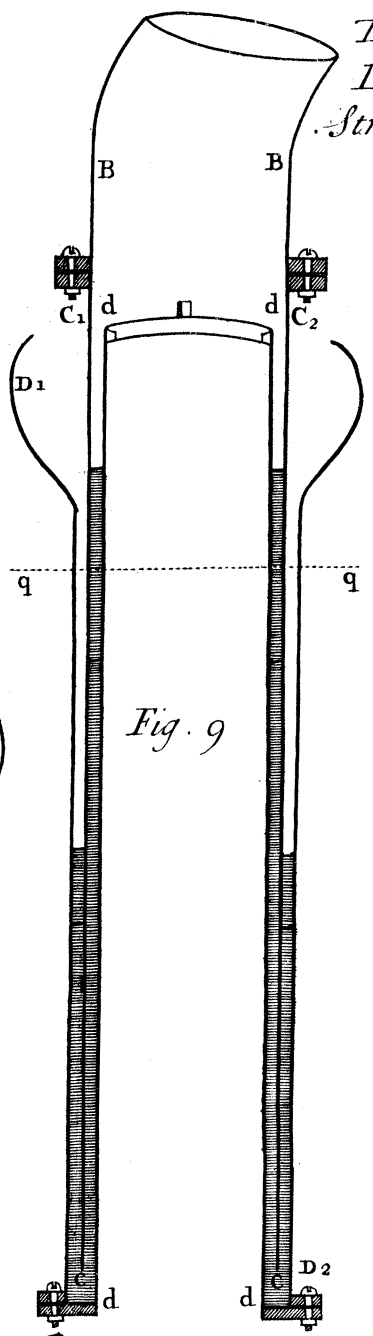
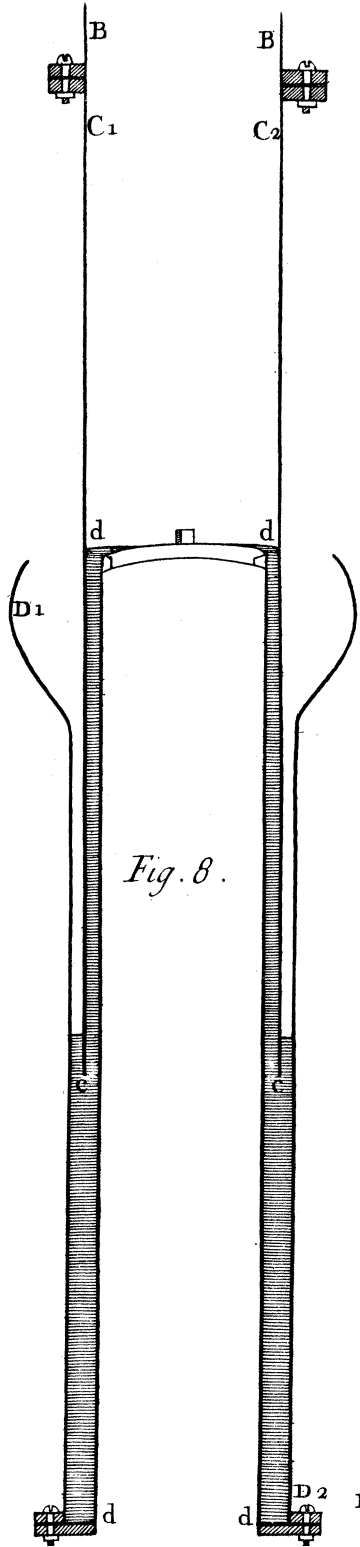
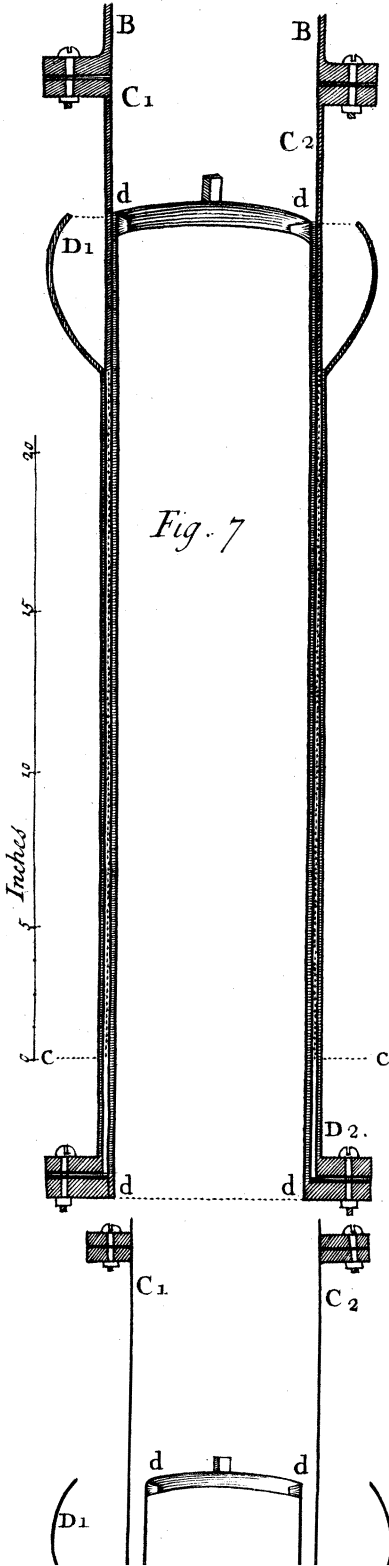

Depth of the Cup 5 Inches
Diameter 10.5
Length of Pendulum 9 foot
Thickness in $\frac{1}{4}$ Cylinder 13 Inches

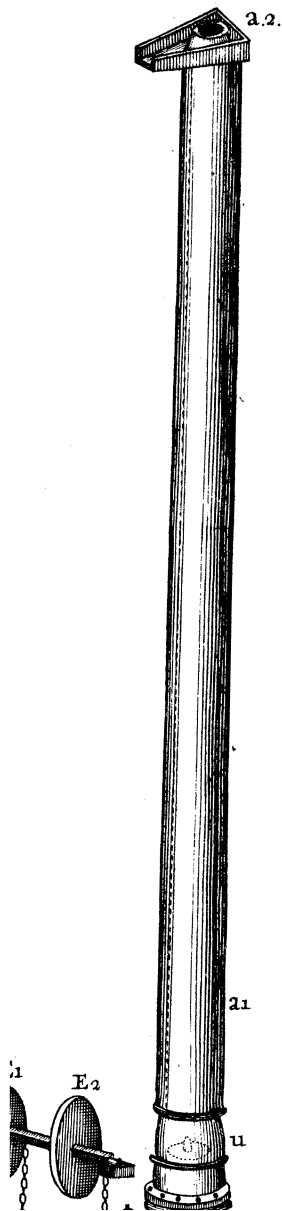

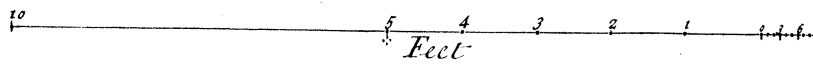
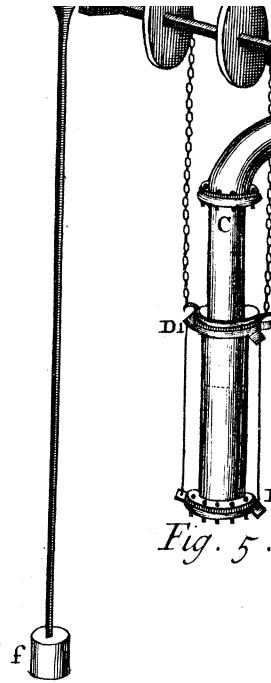
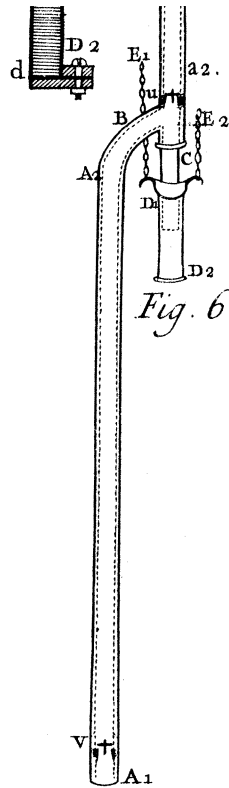
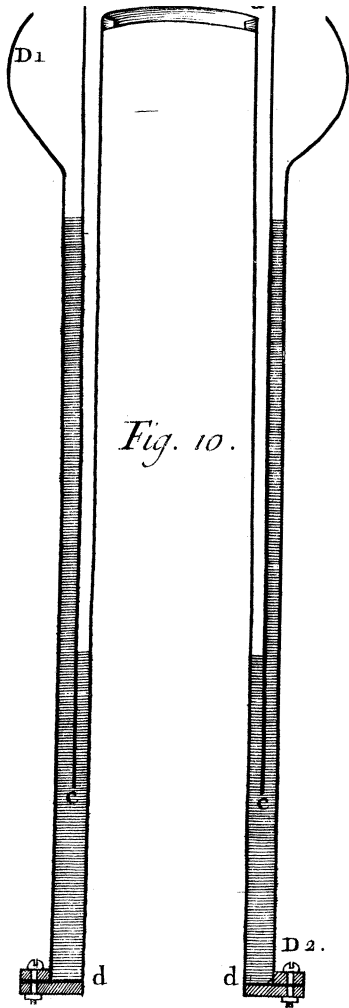

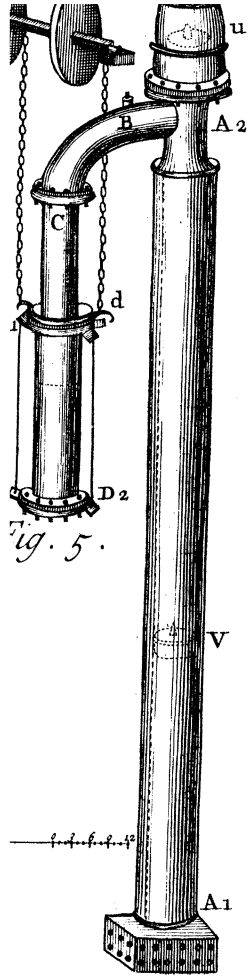

Fig. 5.

	Inner Cylinder. <i>feet Inch^s tenth^s</i>	2 ^d . or Mid. Cylinder. <i>f. i. t.</i>	Out ^r Cylinder <i>f. i. t.</i>
Length	2.7.2	2.5.0	2.6
Diameter within	0.6.03	6.35	
Thickness	0.13	0.08	
Distance between Outer & Inner Cylinder 0.225			

Depth of the Cup 5 Inches
Diameter 10.5
Length of Pendulum 9 foot
Stroke in $\frac{1}{4}$ Cylinder 13 Inches

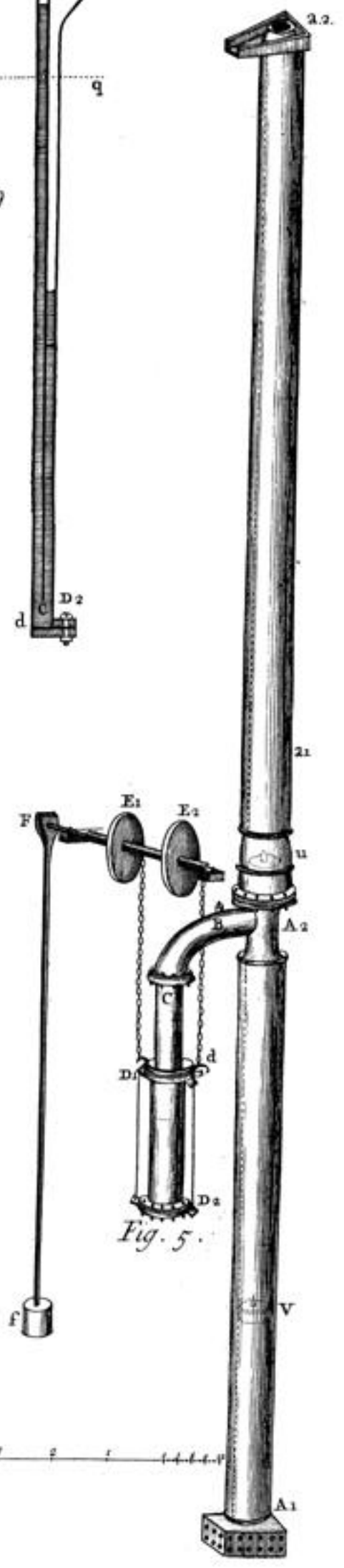
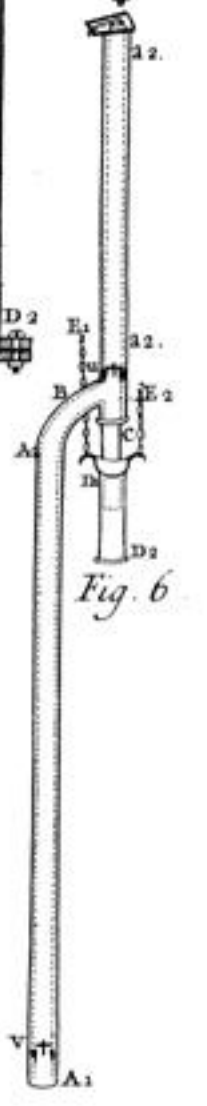
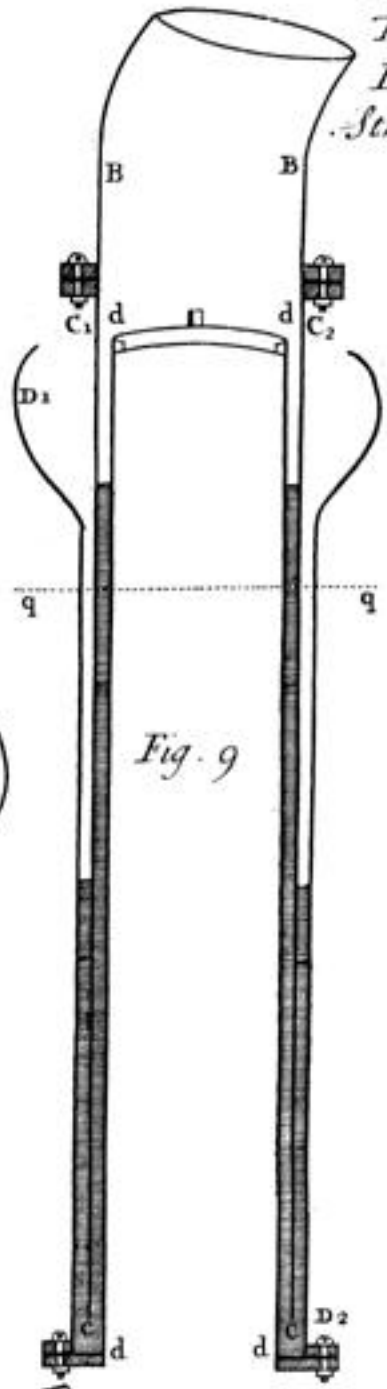
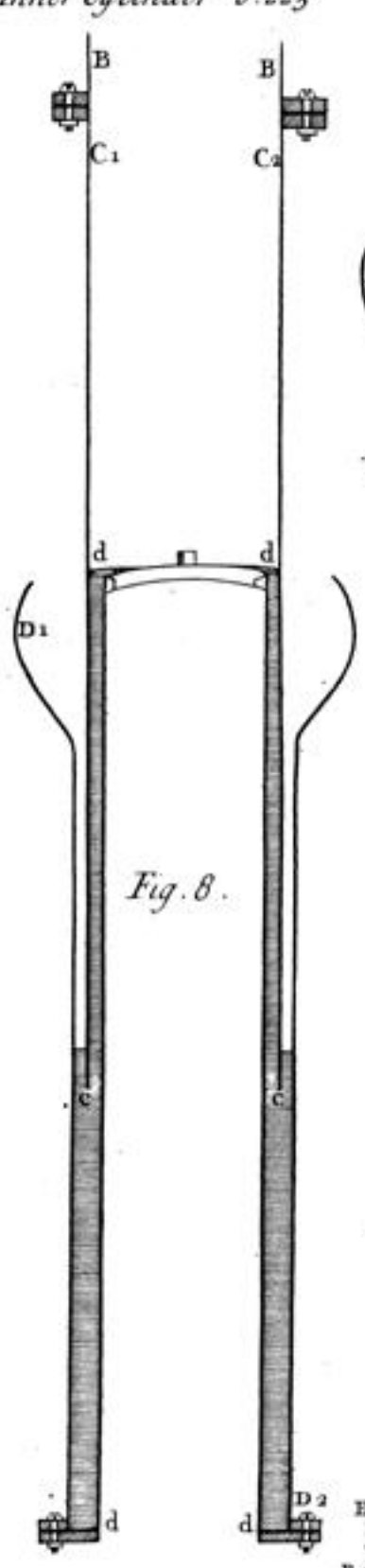
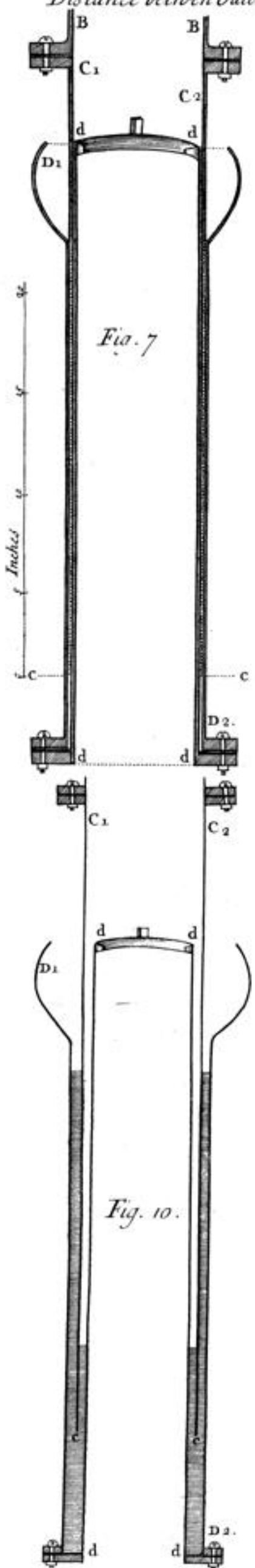

Fig. 10.

Feet