

Vincenzo Fontana

architettura e rappresentazione

Galleria del duomo
di Strasburgo 1263
Many images come
from wikipedia and
from archives of
museums of
Cathedrals Koln,
Strasbourg, Opera
del Duomo, di Siena,
di Firenze, Fabbrica
di S. Pietro, dal
catalogo della
mostra <<Il
Rinascimento>>,
Palazzo Grassi 2000.

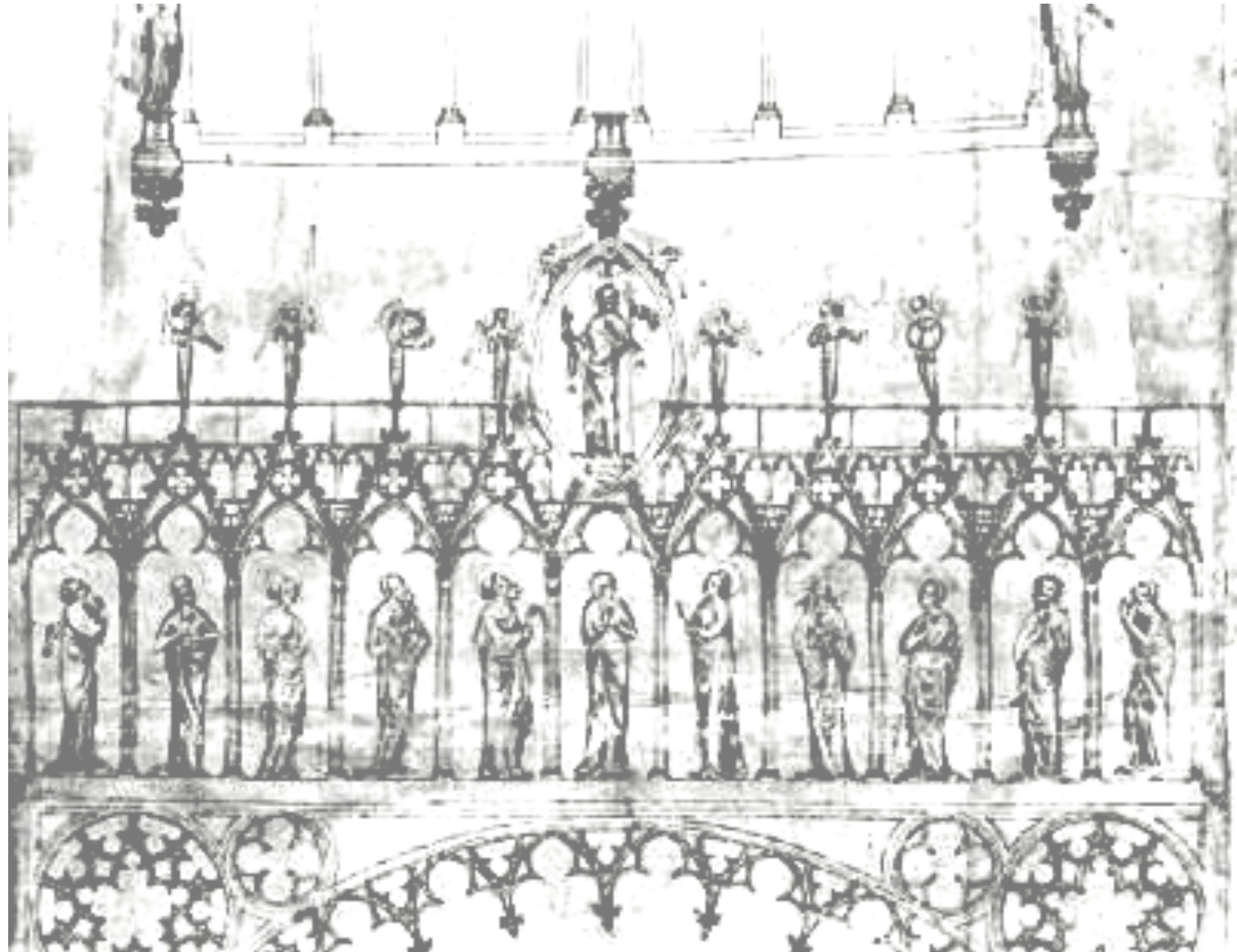



Prospetto laterale di un tempio egizio,
London University College,
Cantembury cattedrale e annessi xii sec

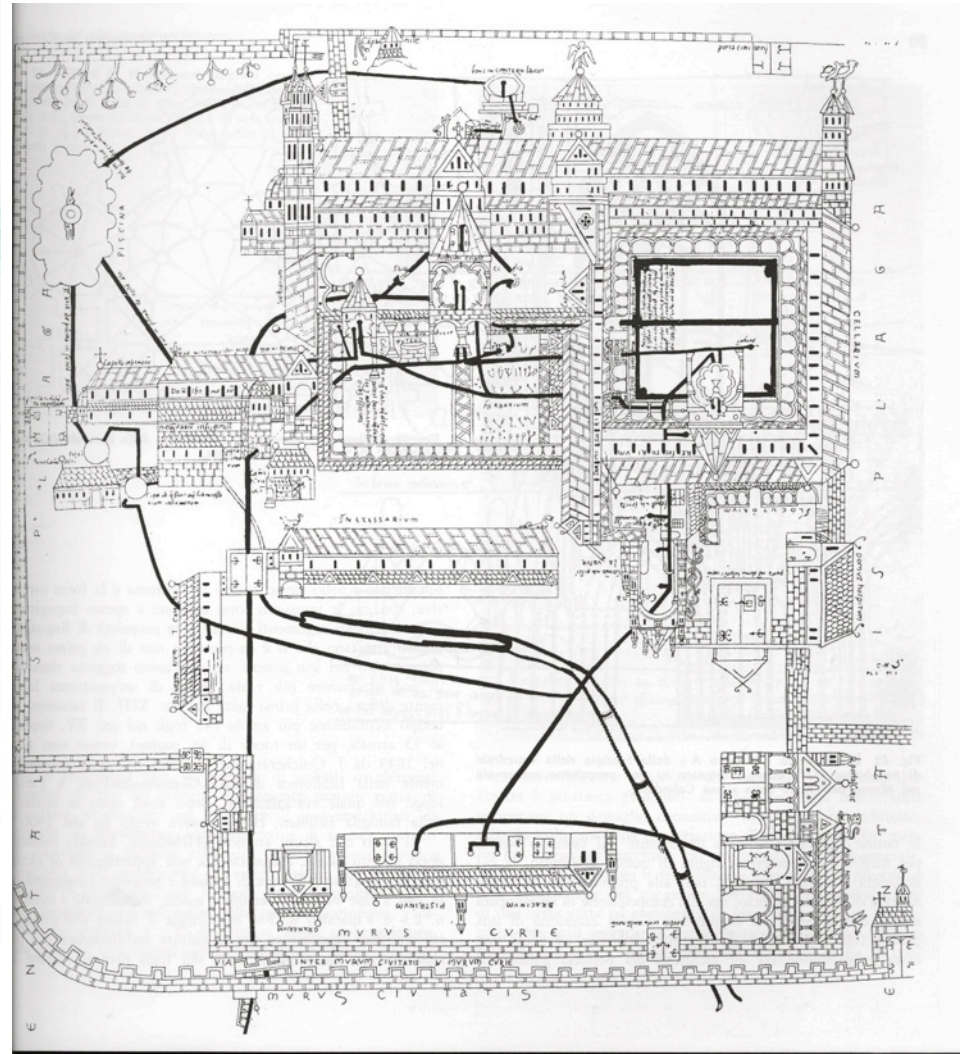

Forma Urbis Romae 210 d.C. circa

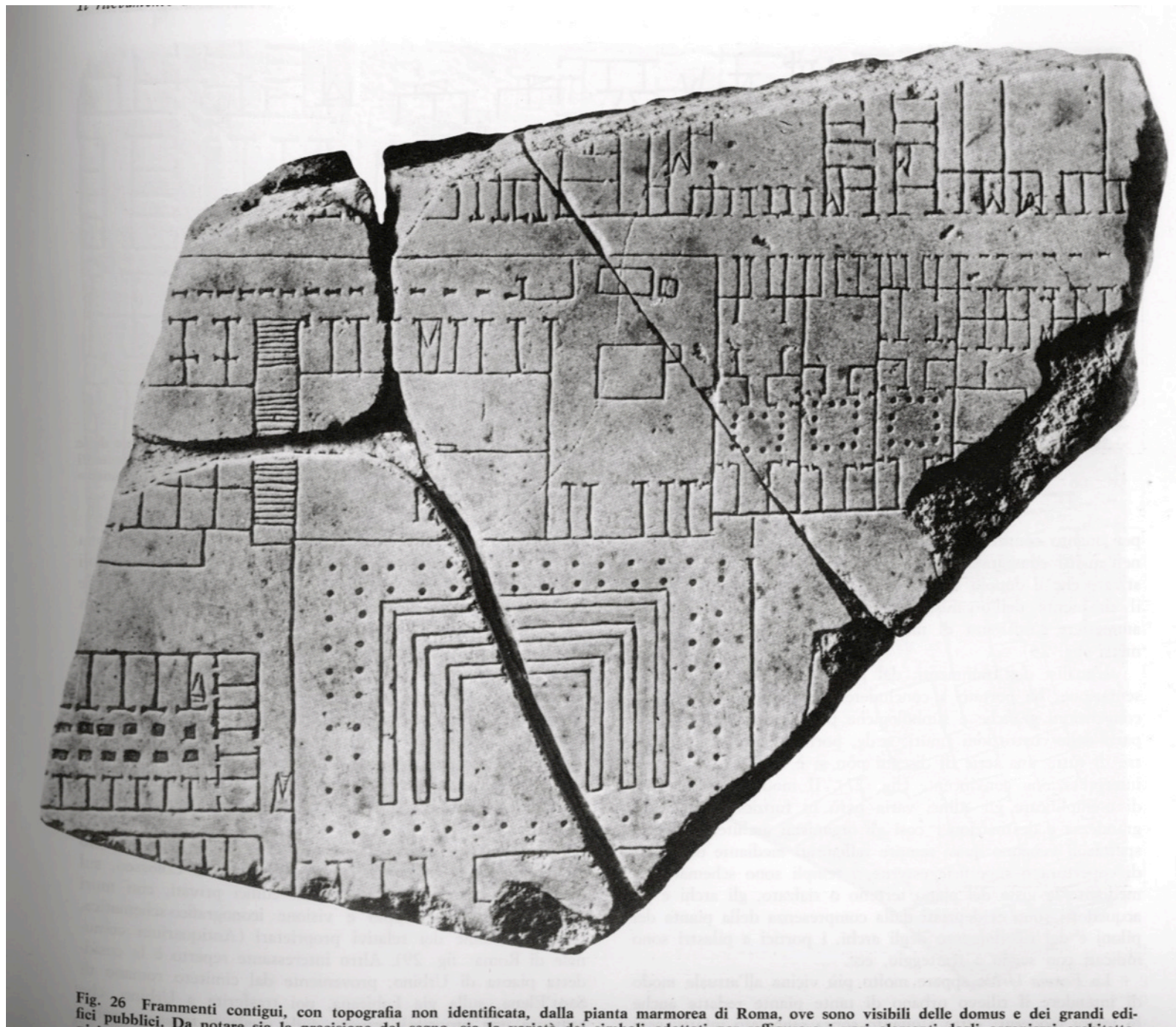
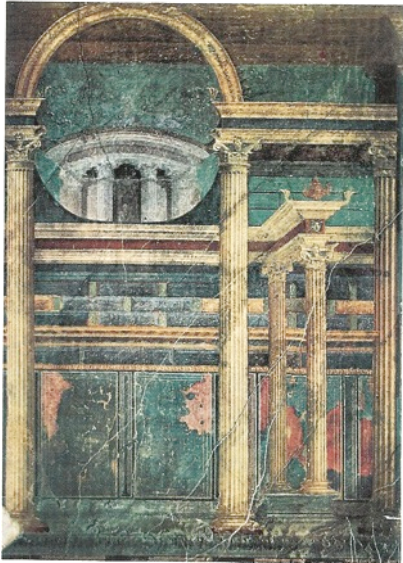

Fig. 26 Frammenti contigui, con topografia non identificata, dalla pianta marmorea di Roma, ove sono visibili delle domus e dei grandi edifici pubblici. Da notare sia la precisione del segno sia la varietà dei simboli adottati per riflettere i vari elementi degli organismi architettonici.

Pompei villa dei misteri, Domus Aurea
Roma, Ercolano iv stile



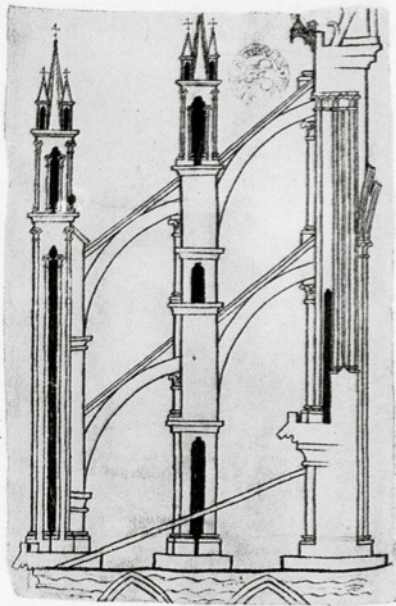

Fig. 3 - Villard de Honnecourt
Sezione della zona superiore
della Cattedrale di Reims

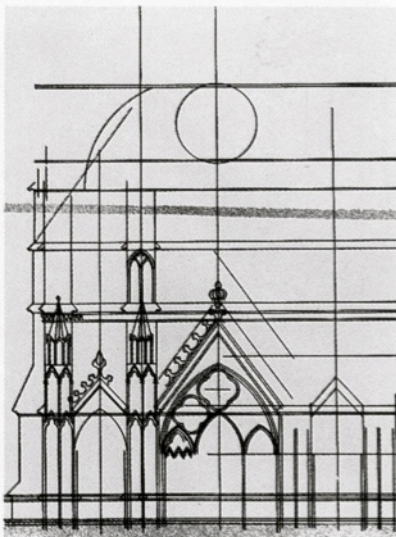

Fig. 4 - Palinseso con progetto
per la Cattedrale di Reims

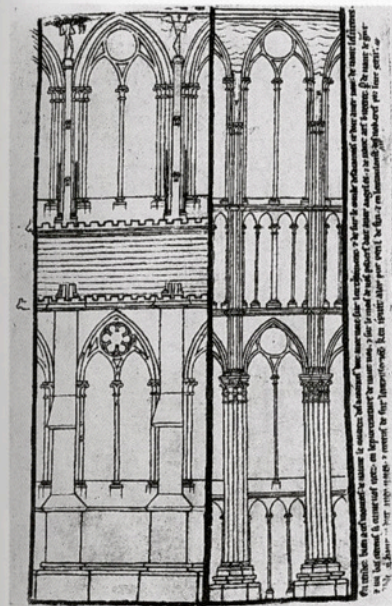
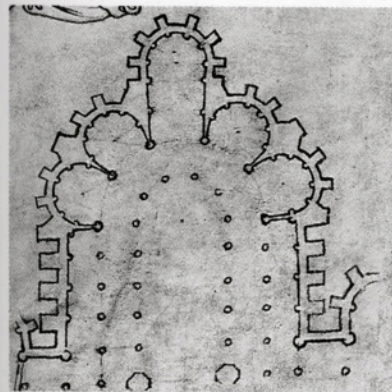
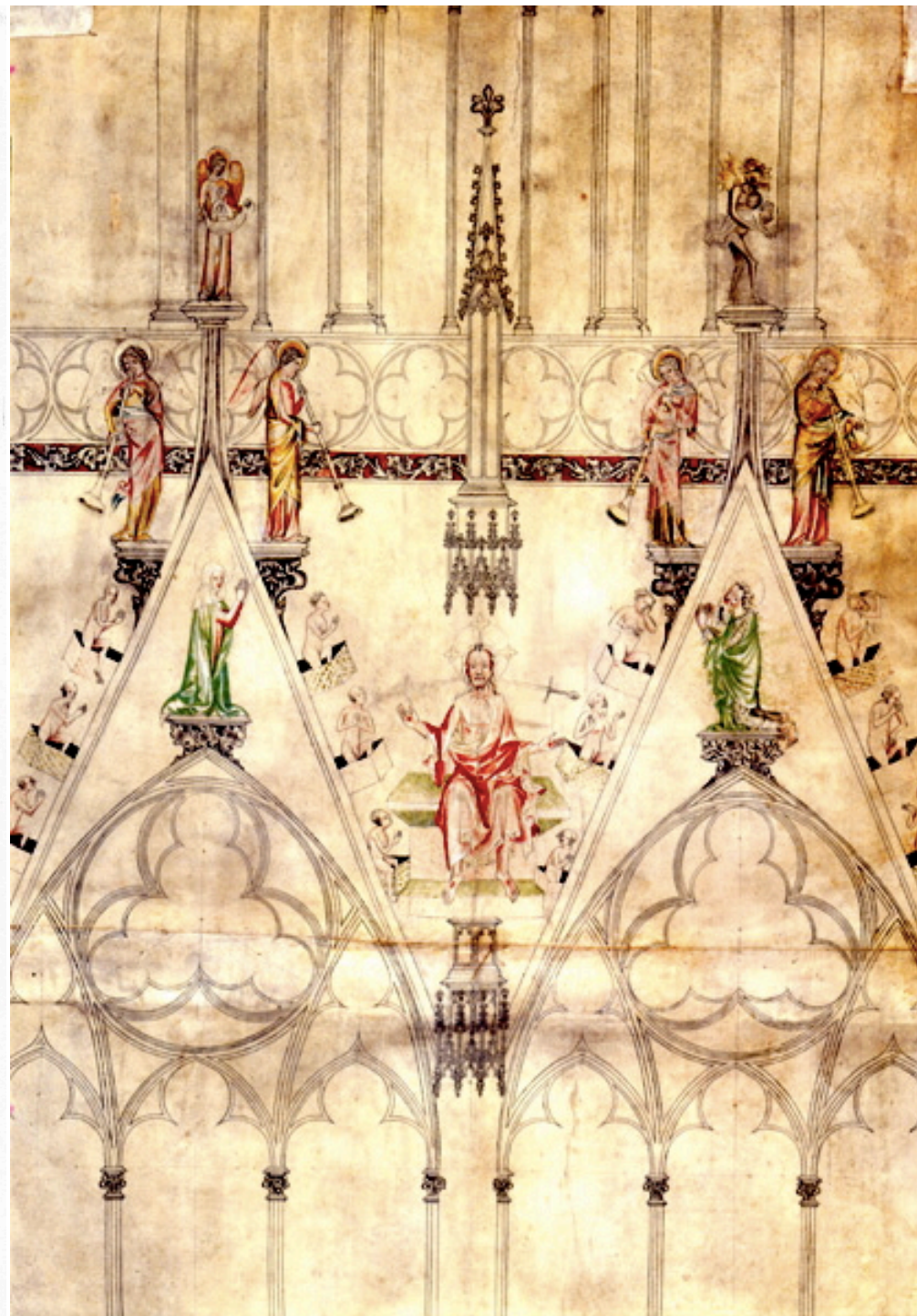

Fig. 1 - Villard de Honnecourt
Pianta
della Cattedrale di Cambrai

Fig. 2 - Villard de Honnecourt
Alzato dell'interno ed esterno
della Cattedrale di Reims





Colonia
westwerk
1300 circa,
Jobin
Strasbourg
cathedral
1574

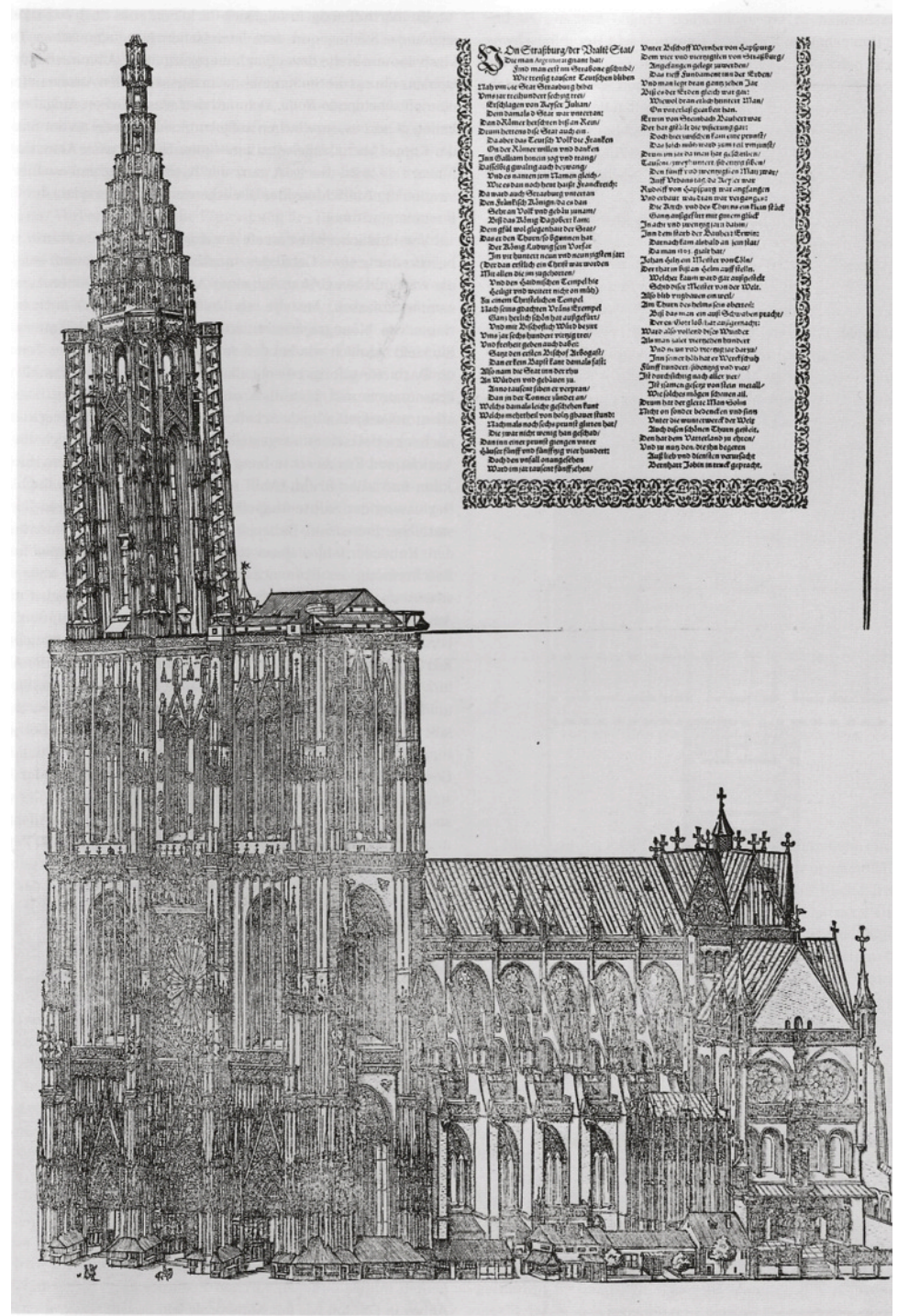

Giuliano da Sangallo Santa Sofia

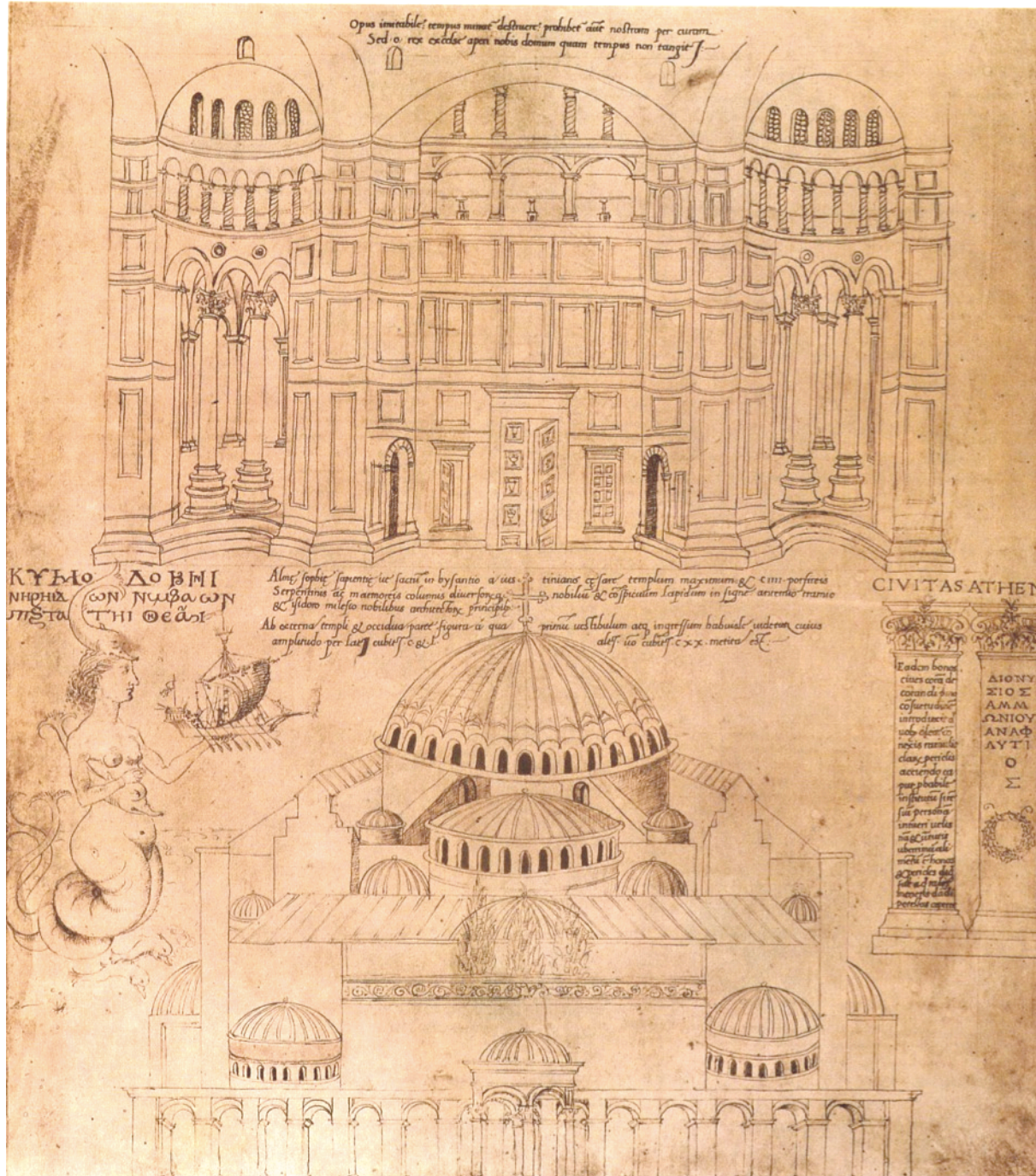

Giotto prospettive



Pianta e sezione del duomo di Milano, XV sec., plastico sezione di San Petronio a Bologna sec, XVI

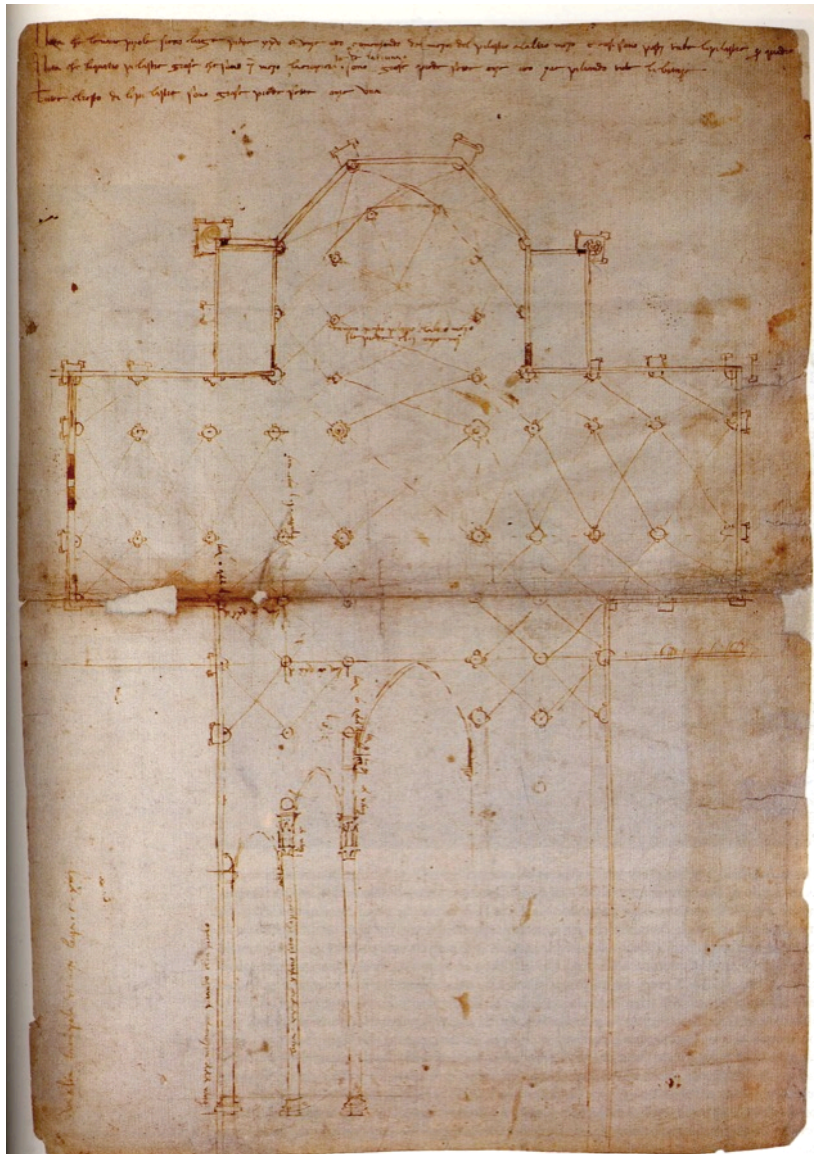
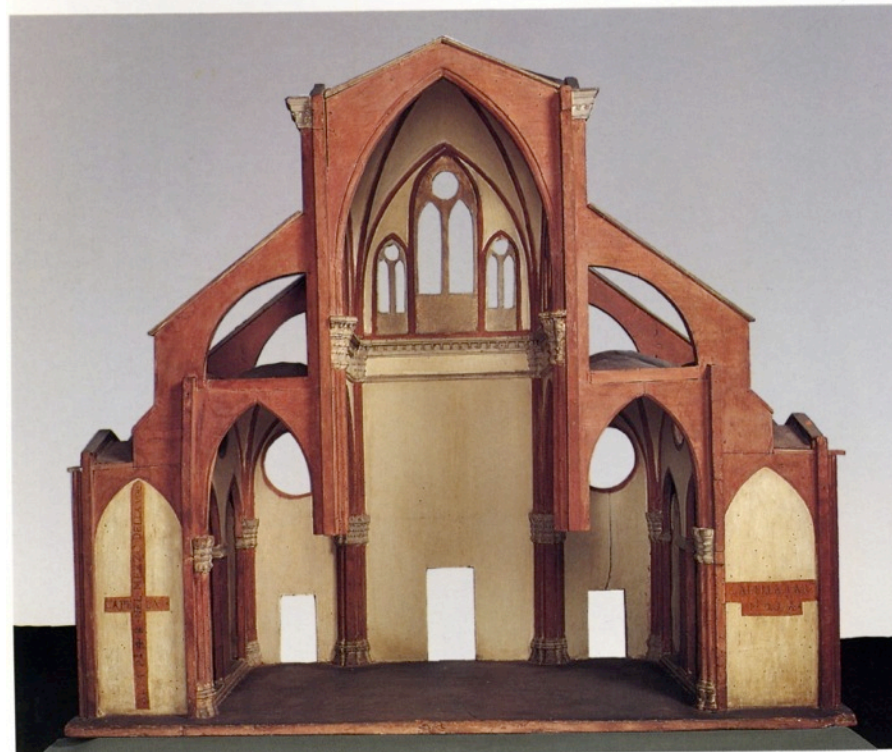
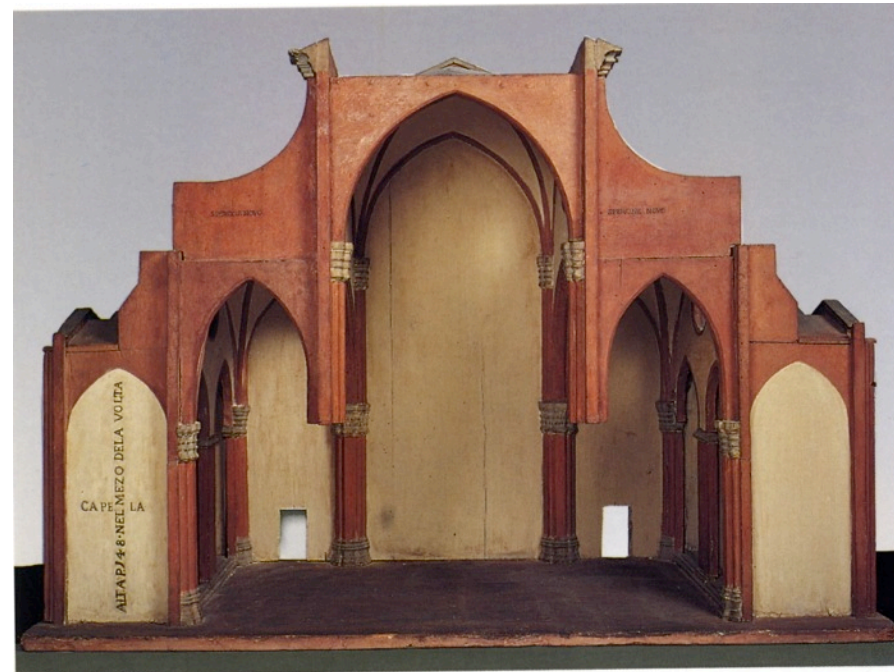
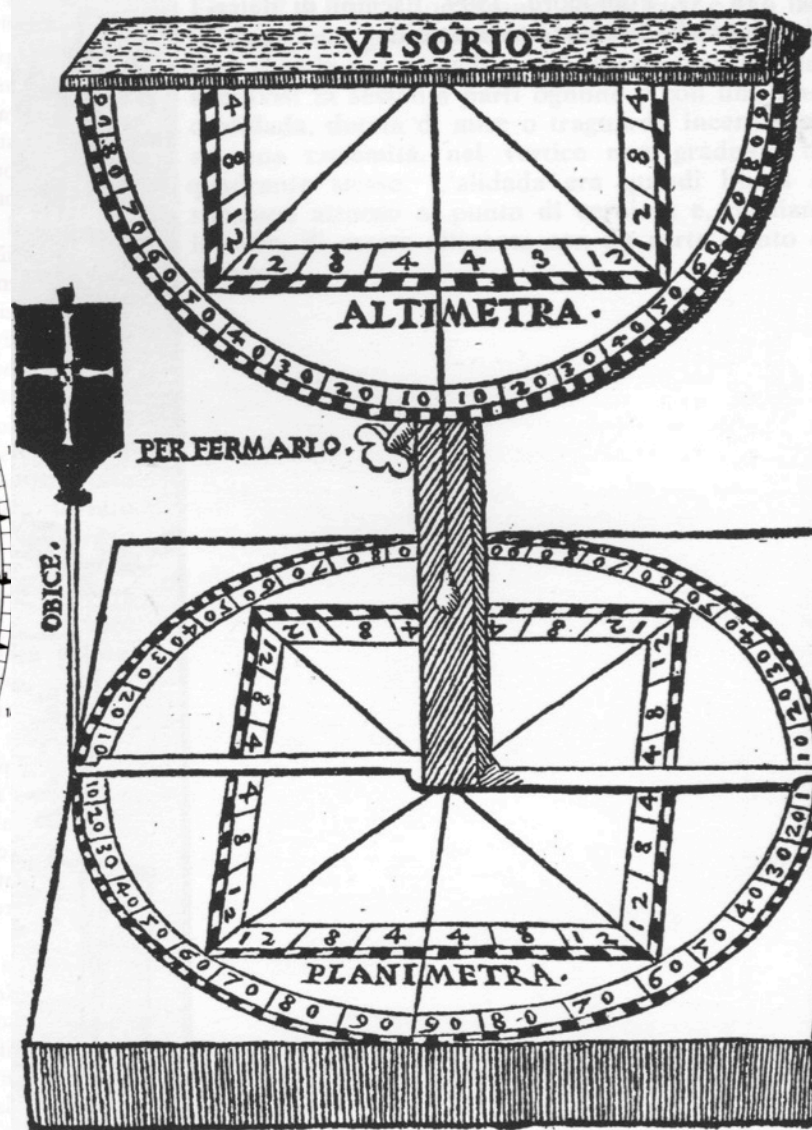
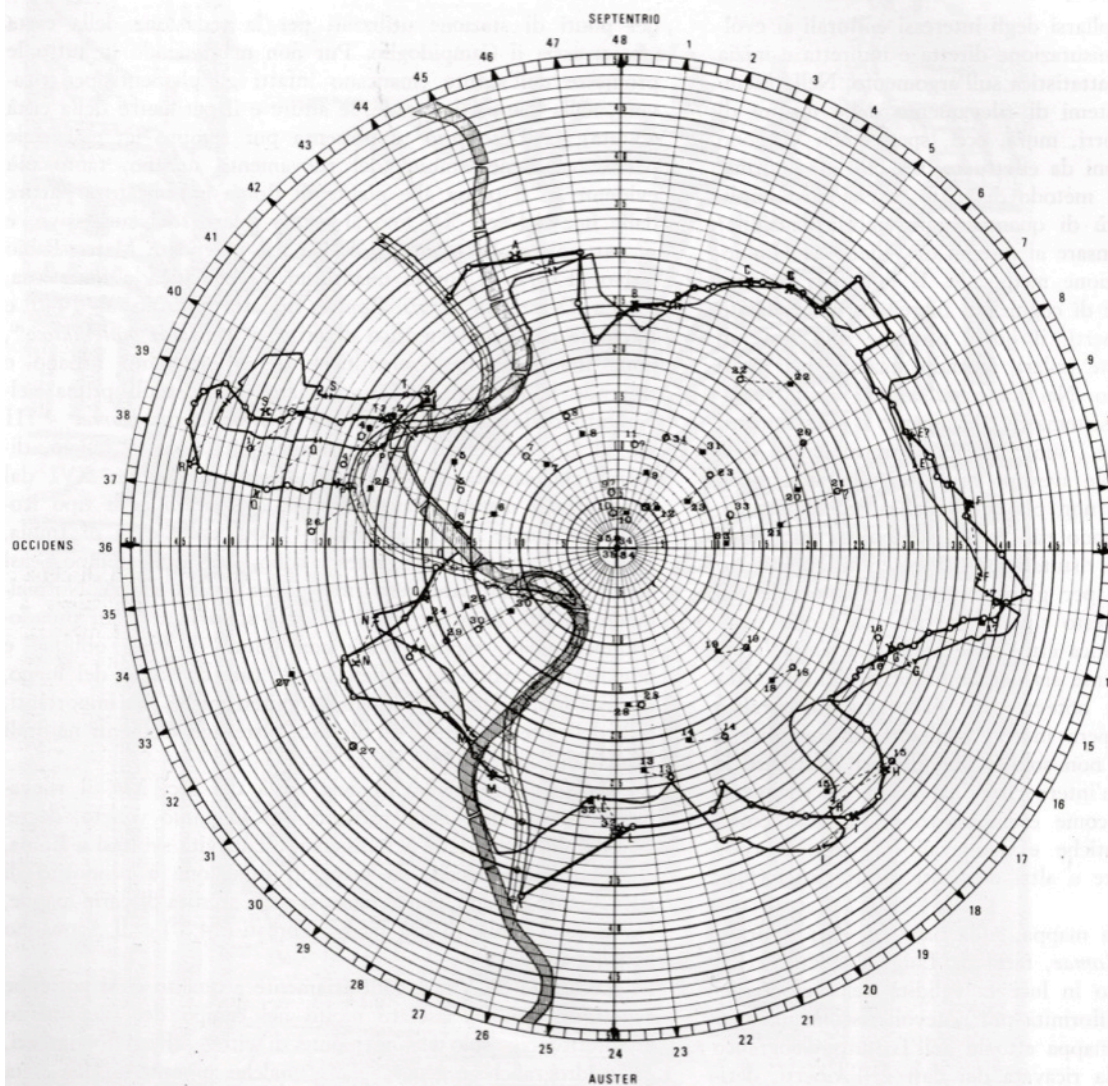

Fig. 5 - Antonio di Vincenzo, rilievi del Duomo di Milano
Bologna, Museo di San Petronio, Cartella 389, n. 1, Cat. n. 6





120 Il « visorio », prima forma del teodolite.

Fig. 104 Leon Battista Alberti. Planimetria della « Descriptio Urbis Romae », disegnata dal Vagnetti in base ai dati nello scritto dell'Alberti; con segno più scuro è tracciata la pianta secondo l'Alberti e con segno più chiaro è tracciata la medesima pianta secondo la planimetria dell'IGM (ediz. 1950, riprod. in rapp. 1:50.000).

Vitruvio Barbaro Palladio 1556, 67, libro I icnografia

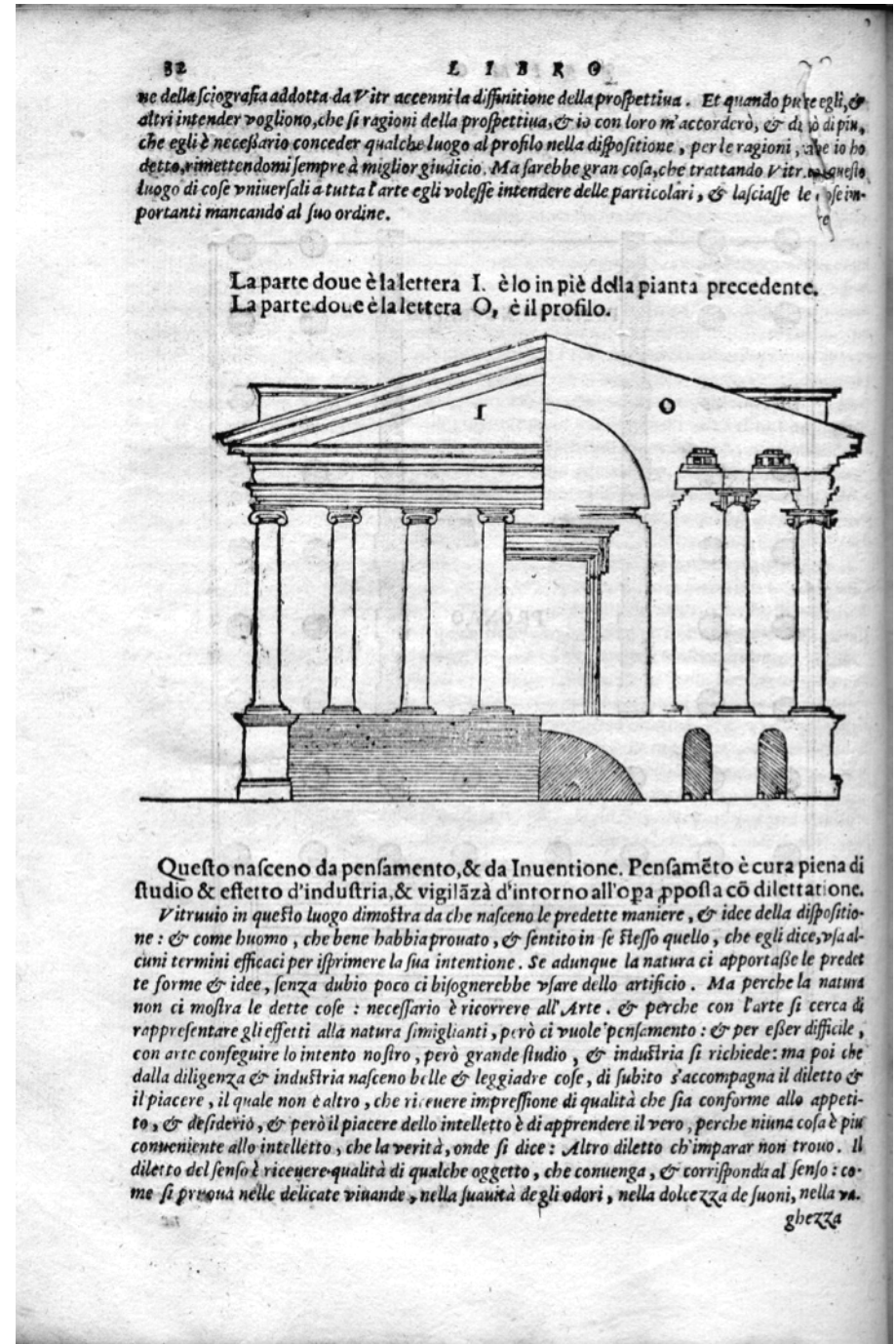
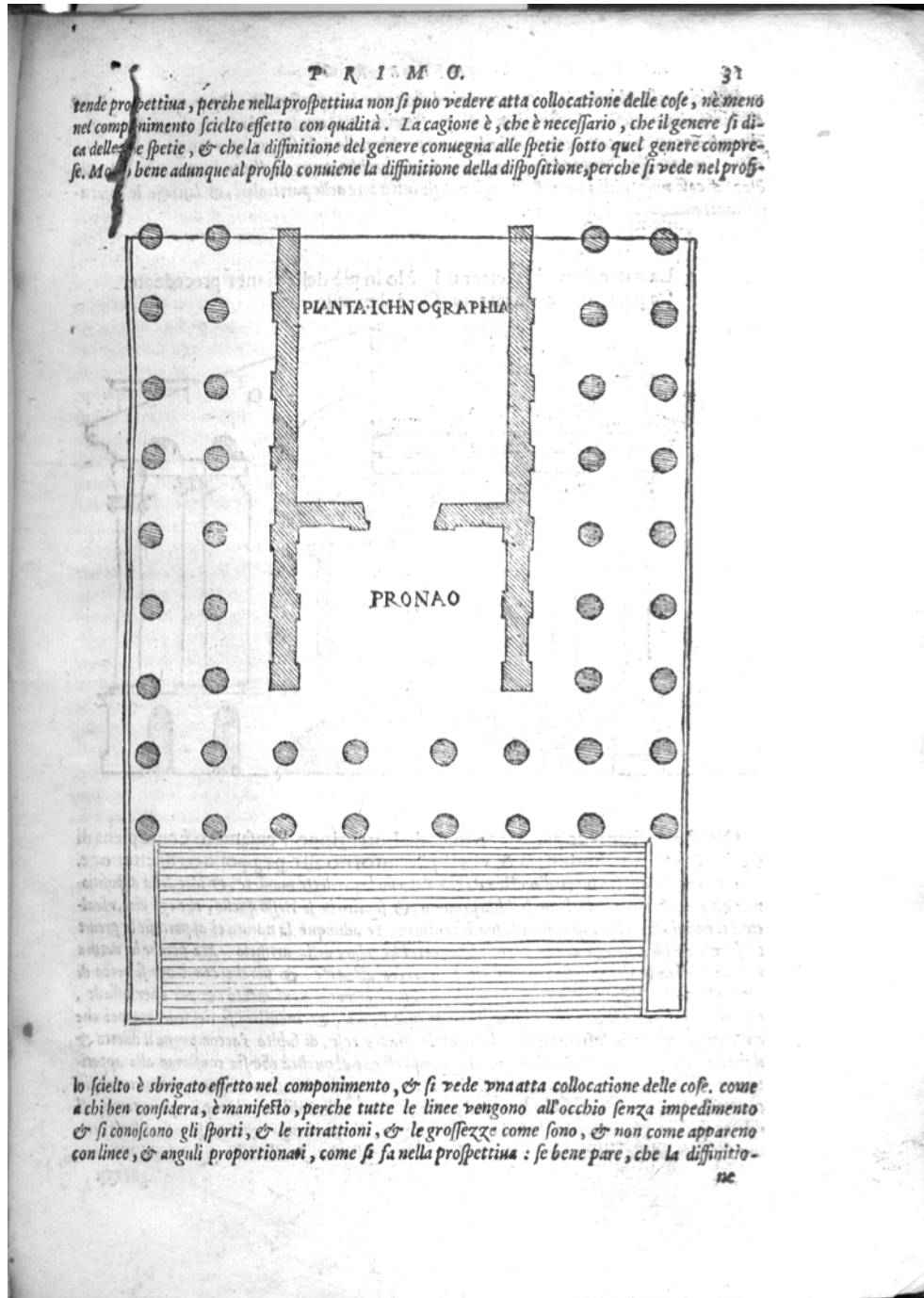

Brunelleschi tavolette 1416

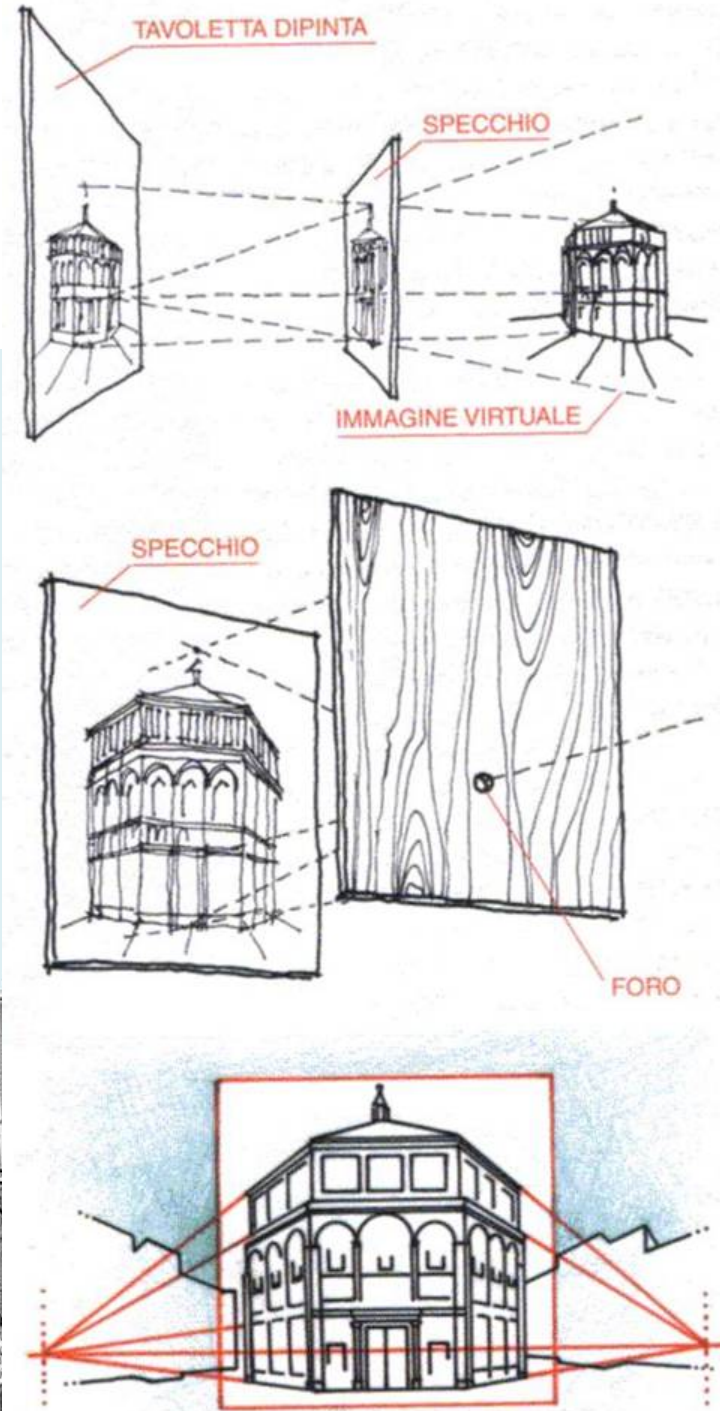

Brunelleschi e Masaccio Trinità s. Maria novella,

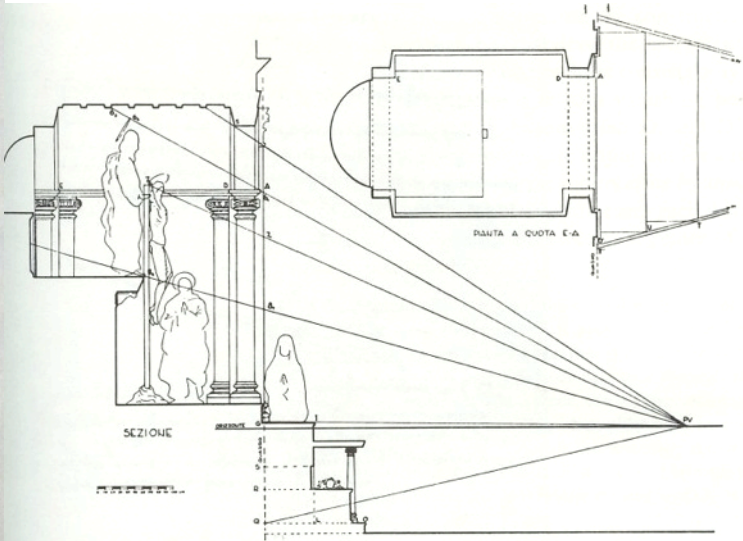
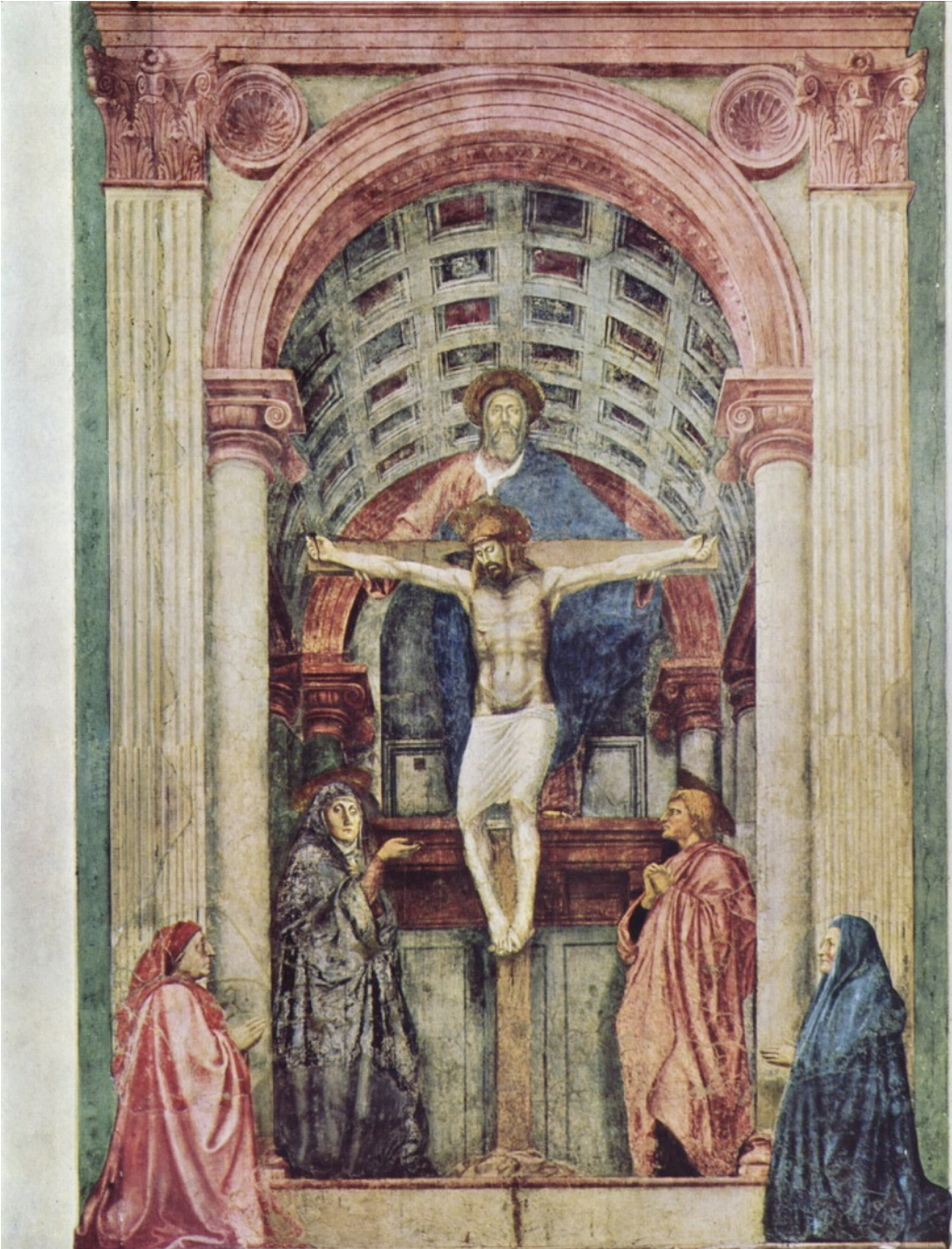

Figure 1-11. Plan and elevation of Masaccio's Trinity according to Sanpaulesi (1962, figure C, opp. p. 52)

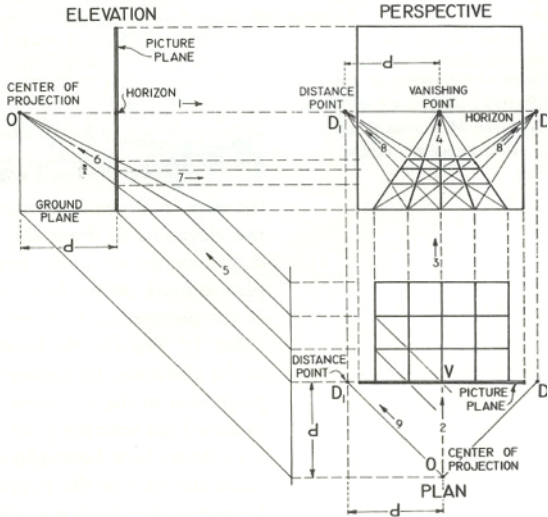
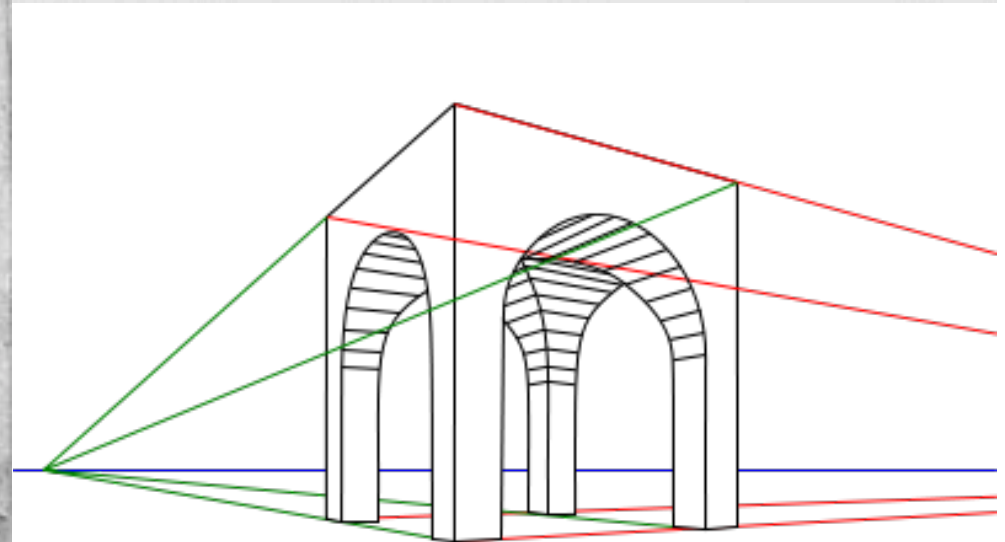
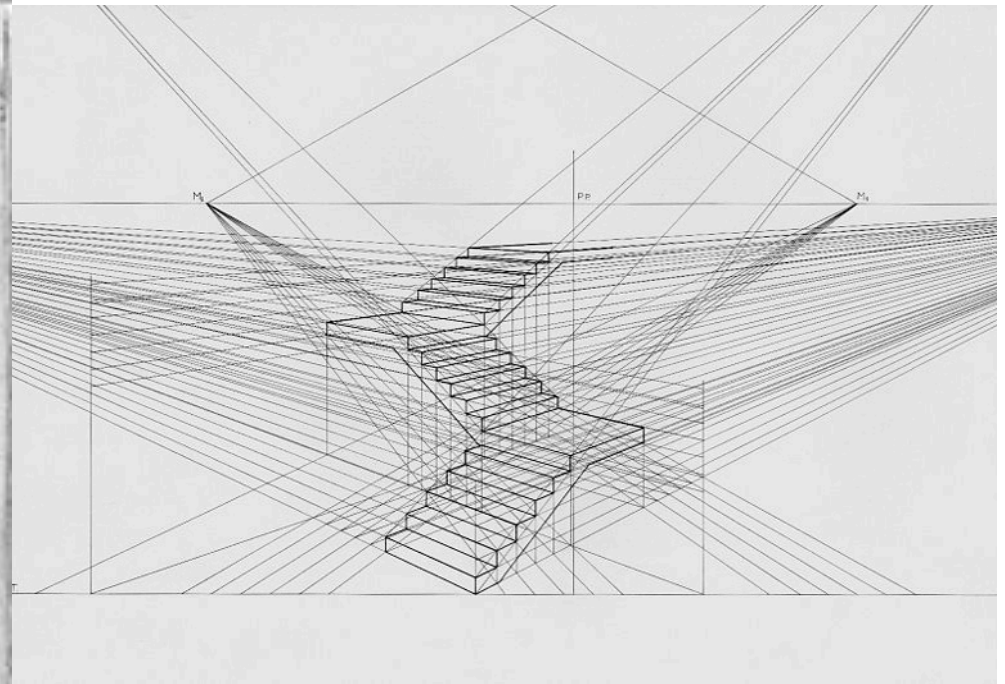
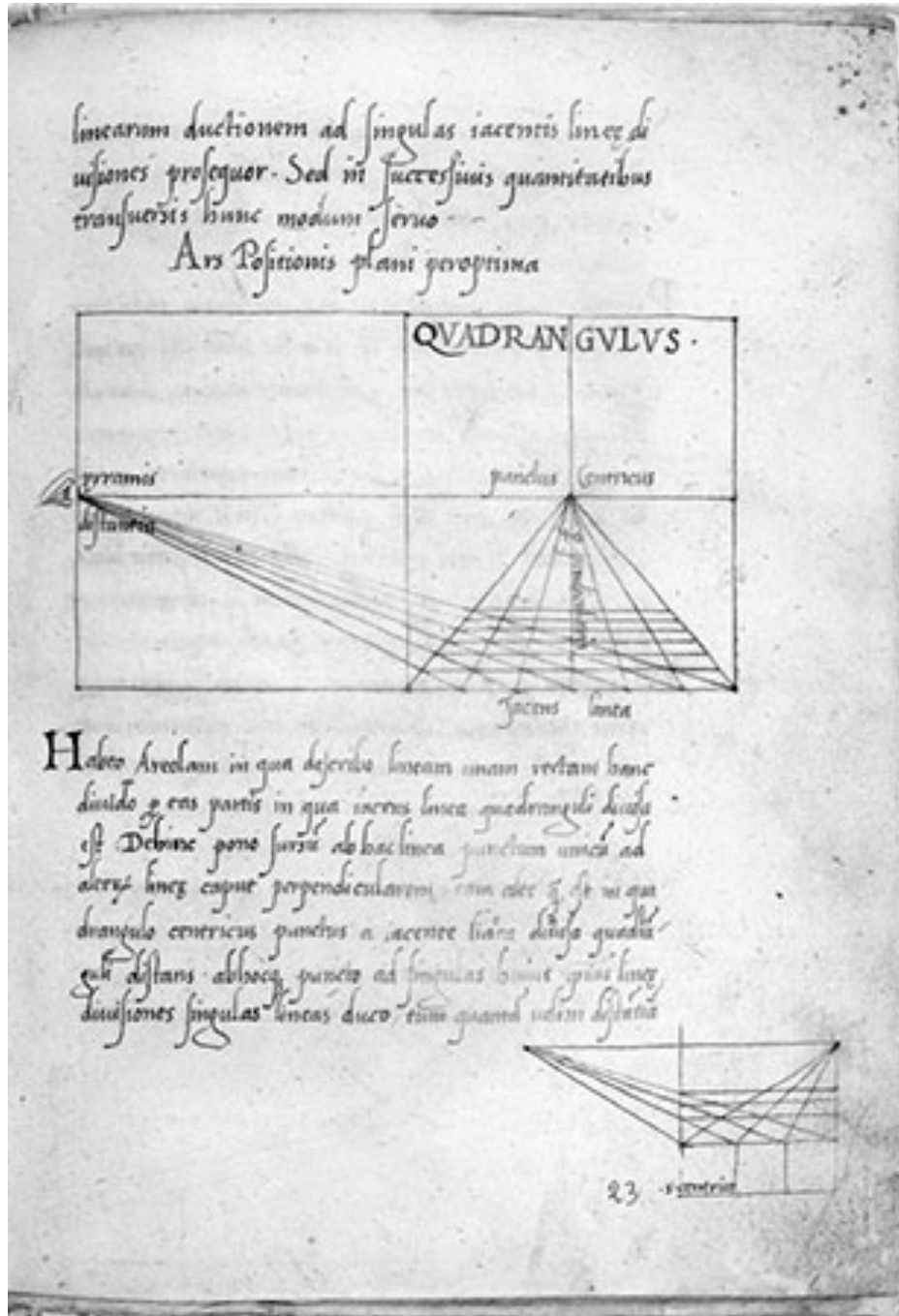

Figure 1-12. Construction of perspective representation of a pavement consisting of square tiles

Alberti De pictura (1436c.a) bib de France ms 1518, prospettiva angolare e accidentale



Brunelleschi modelli per la cupola museo dell' opera fi



GIOVANNI DI GHERARDO DA FIALTO, disegno con osservazioni sul tracciamento della Cupola di SMF, 1426, archivio di stato di Fi, inv. Mostra 158, DAU asson dal basso di S. Lorenzo

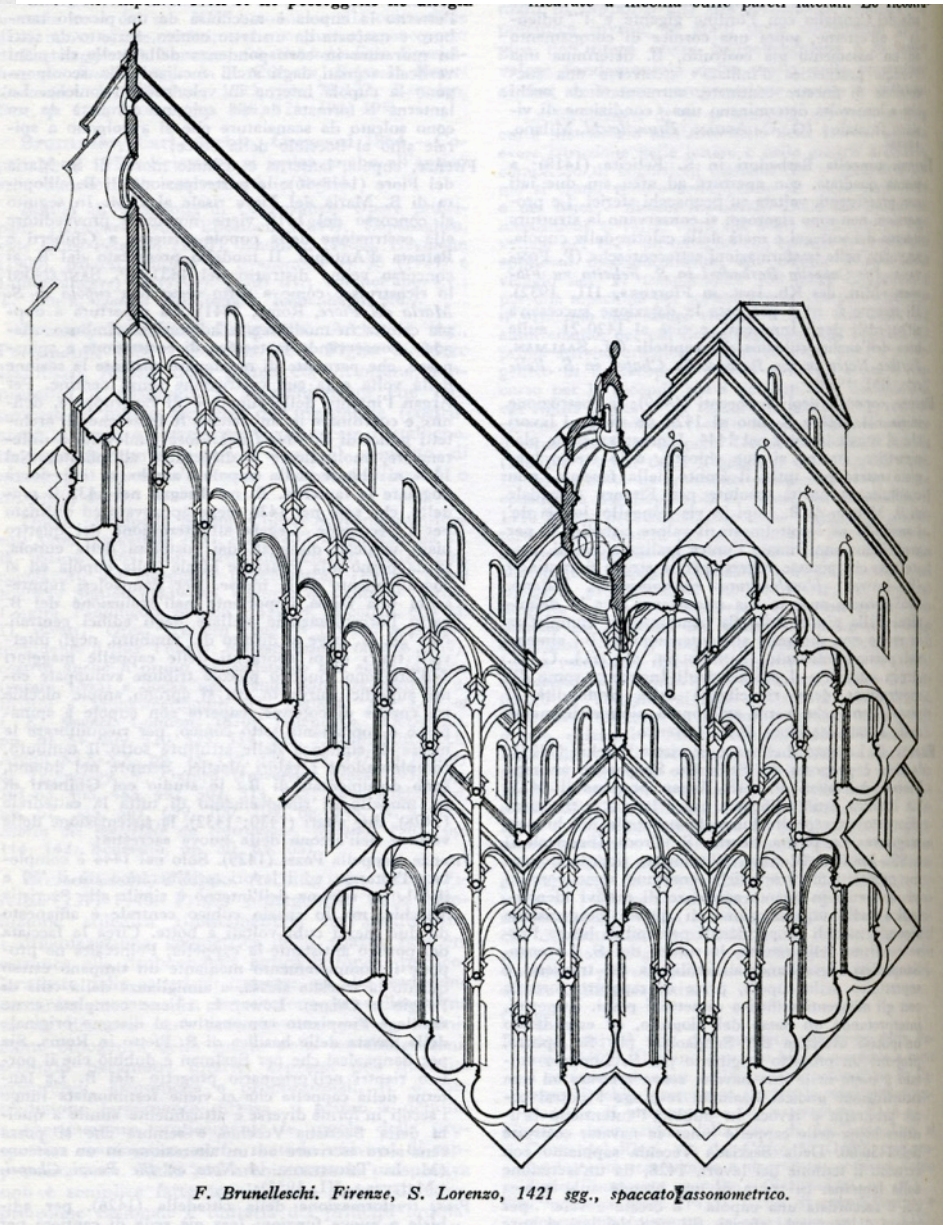
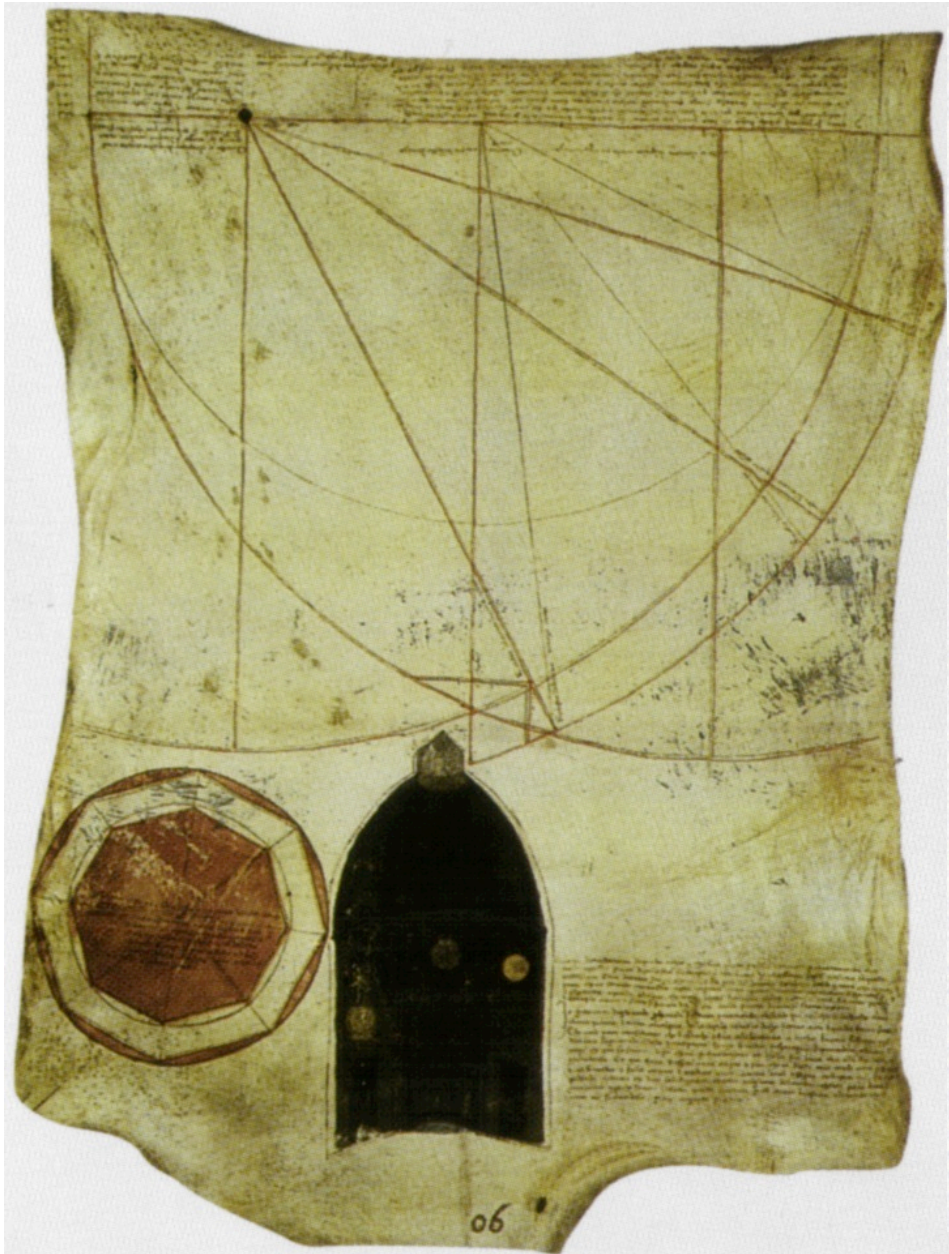

F. Brunelleschi. Firenze, S. Lorenzo, 1421 sgg., spaccato assonometrico.

Giuliano da Sangallo modello di Palazzo Strozzi, Bargello FI



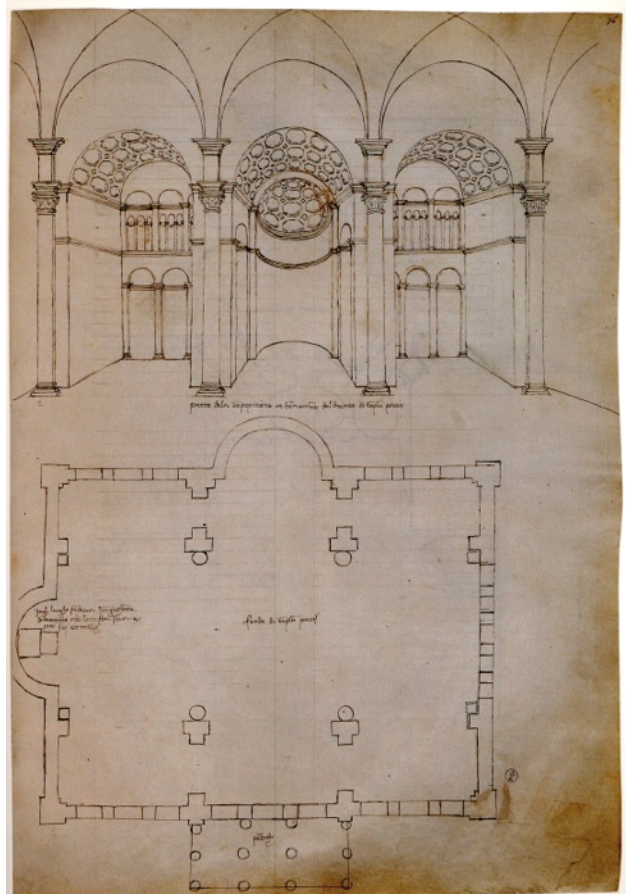

Giuliano da Sangallo, S. Maria delle carceri a Prato, 1485-95
pianta

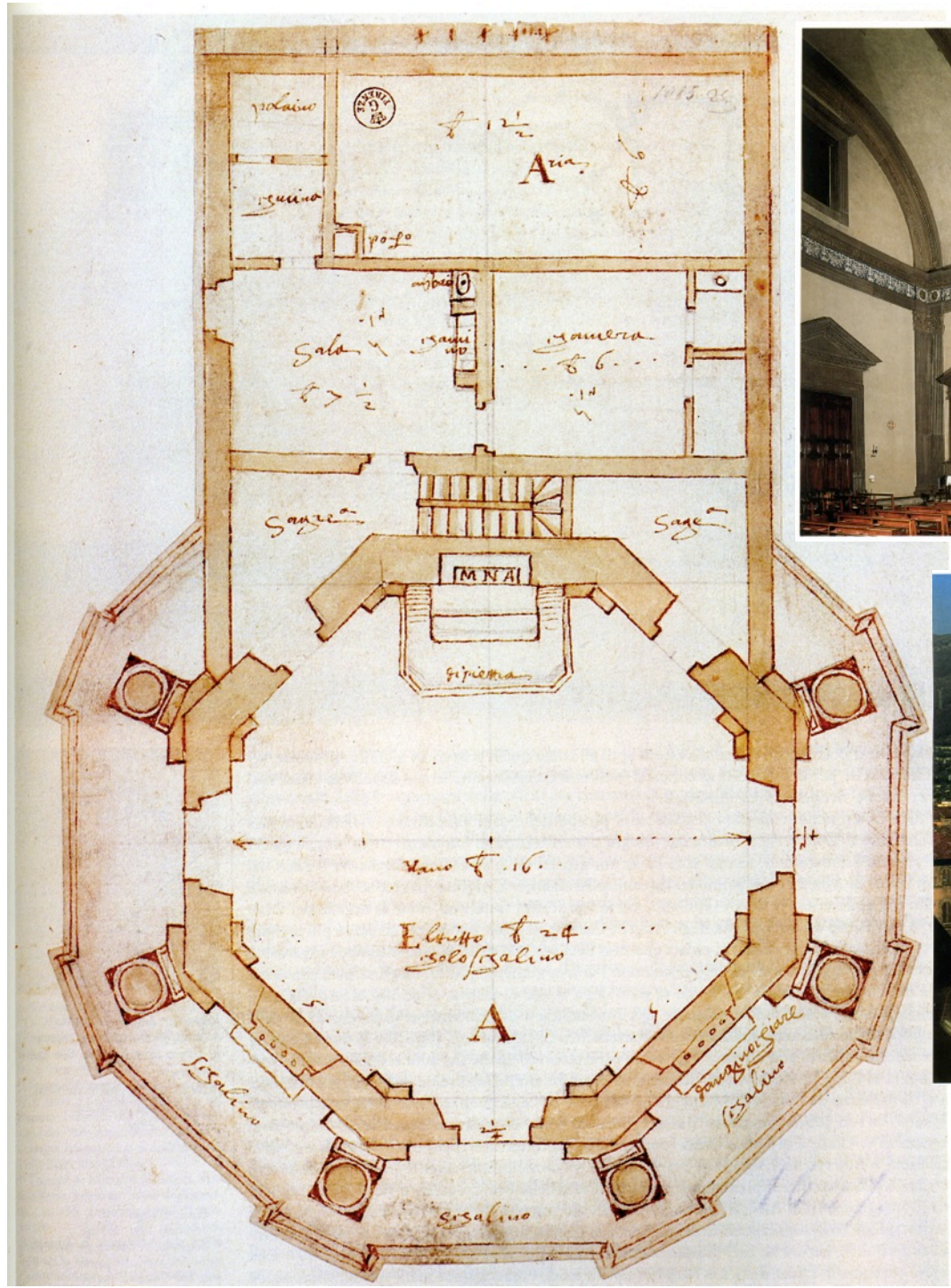



Bramante San Pietro 1506



Antonio da Sangallo il Giov San Pietro 1544





Antonio da Sangallo il Giovane a Antonio Labacco modello per S. Pietro 1544



Bramante s. maria pressos sattro milano 1482-86, borromini galleria pal spada roma dopo 1632



Baldassarre Peruzzi prog S. Pietro, Uffizi 2 A Dosio Pantheon 1569

5. Baldassarre Peruzzi: progetto per San Pietro, progetto per San Pietro
irenze, Uffizi 2 A

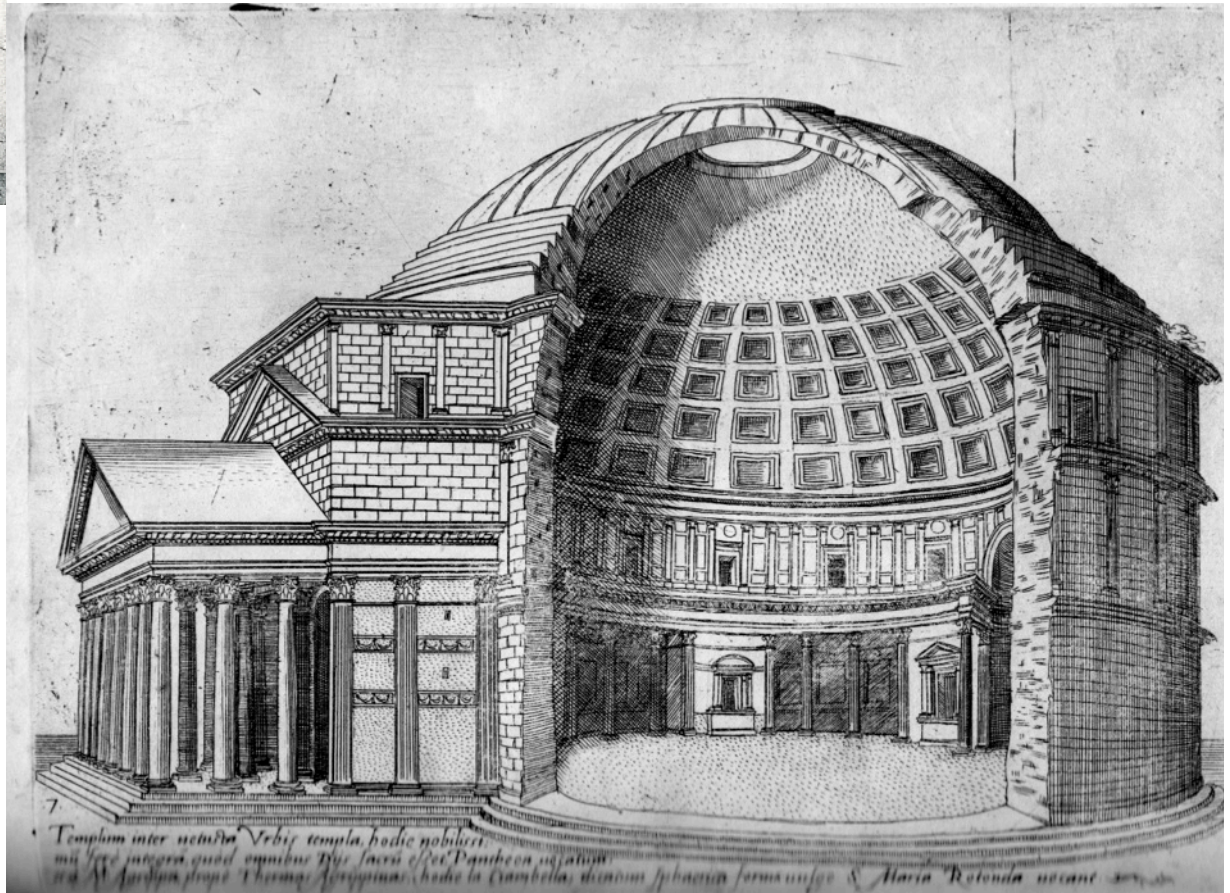
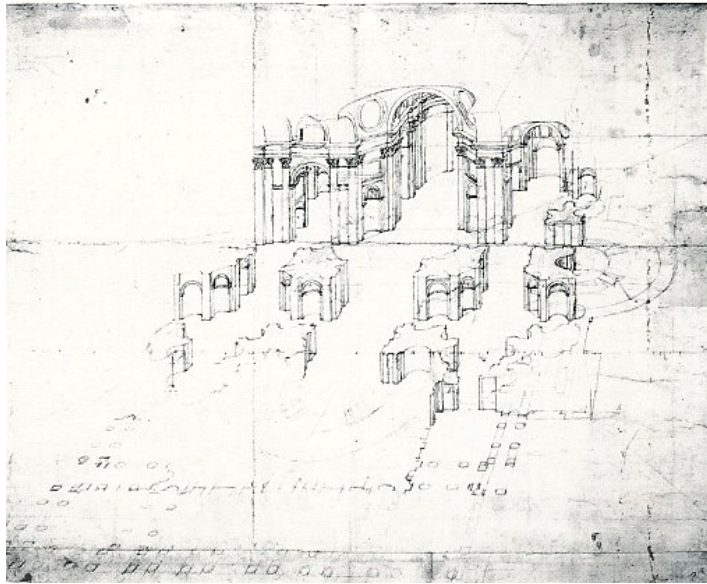

Andrea Pozzo cupola 1685 e soffitto S. Ignazio
Roma 1690-95

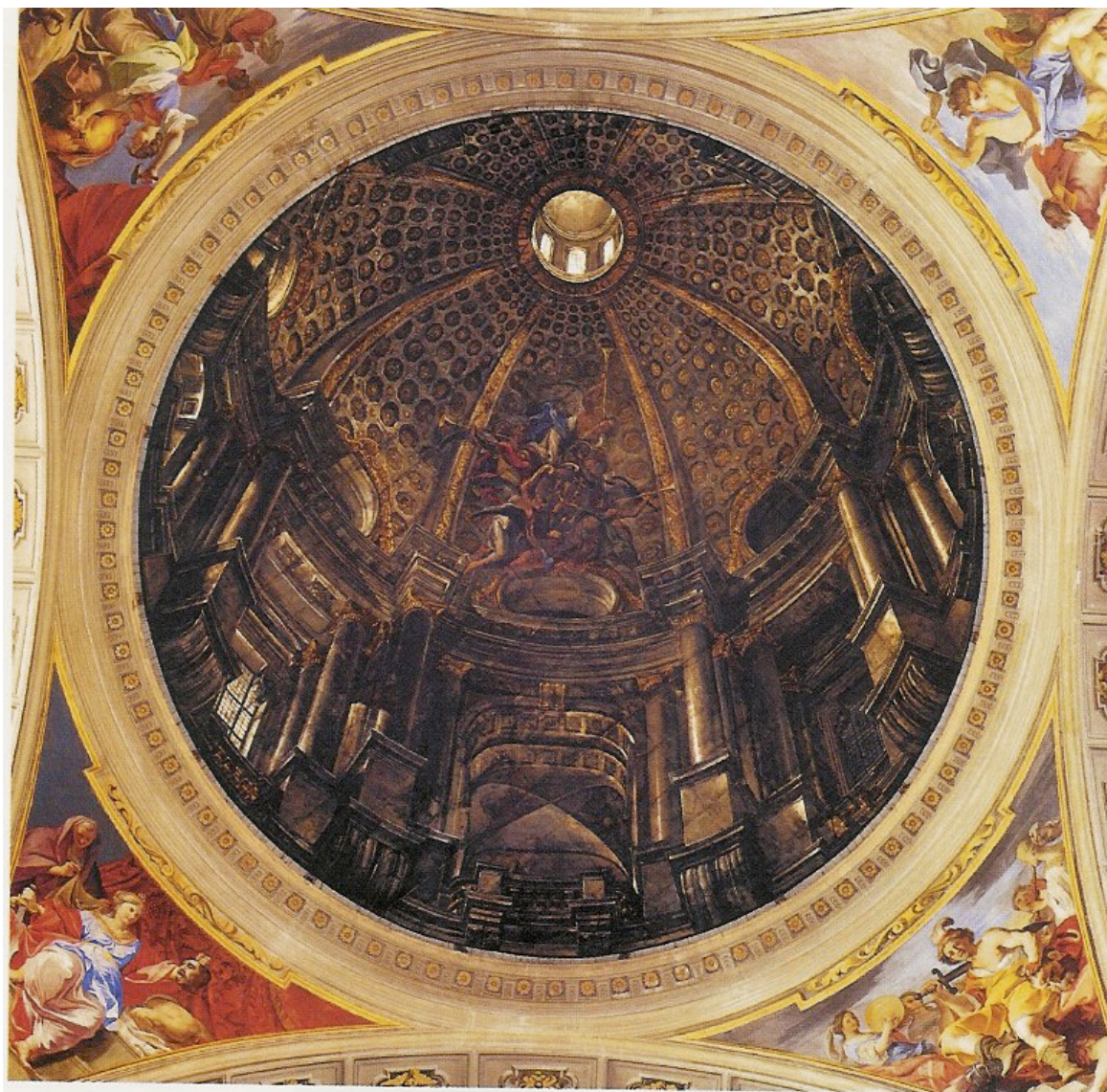

Prospettiva centrale e angolare

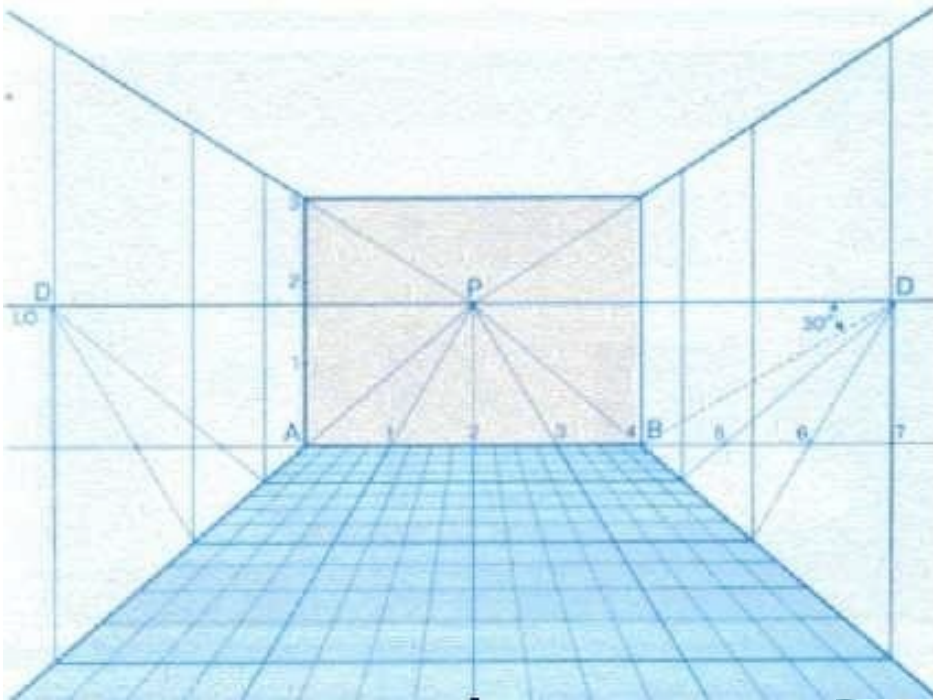

bestepe koru sitesi (living room)



ozhan.deviantart.com
designed by
Ozhan Hazirlar

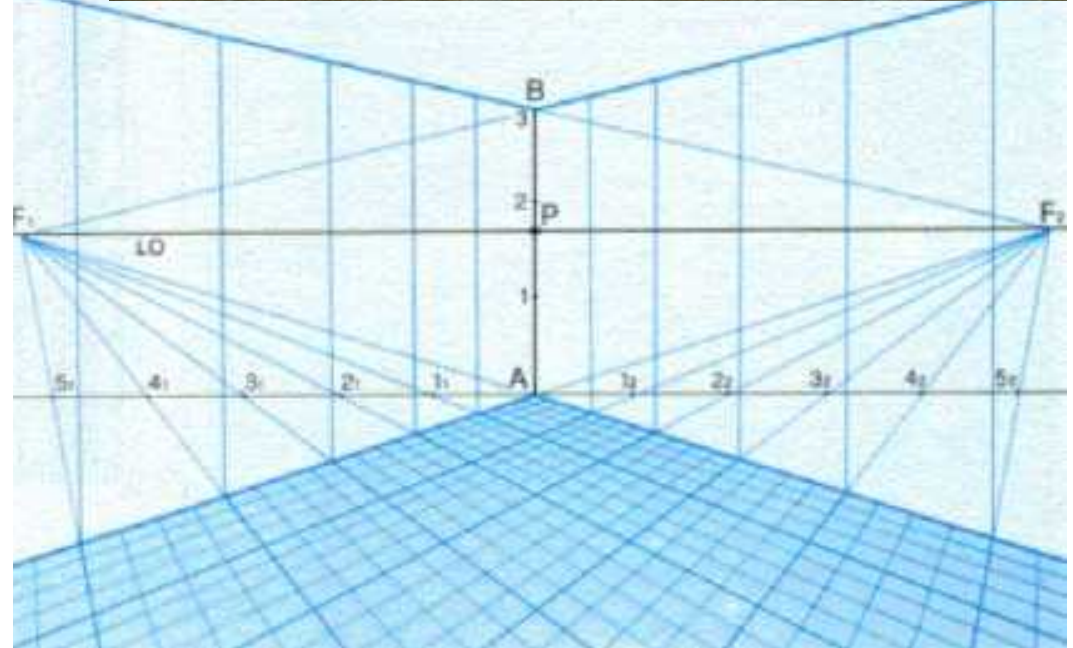

Ferdinando Bibbiena prosp angolare

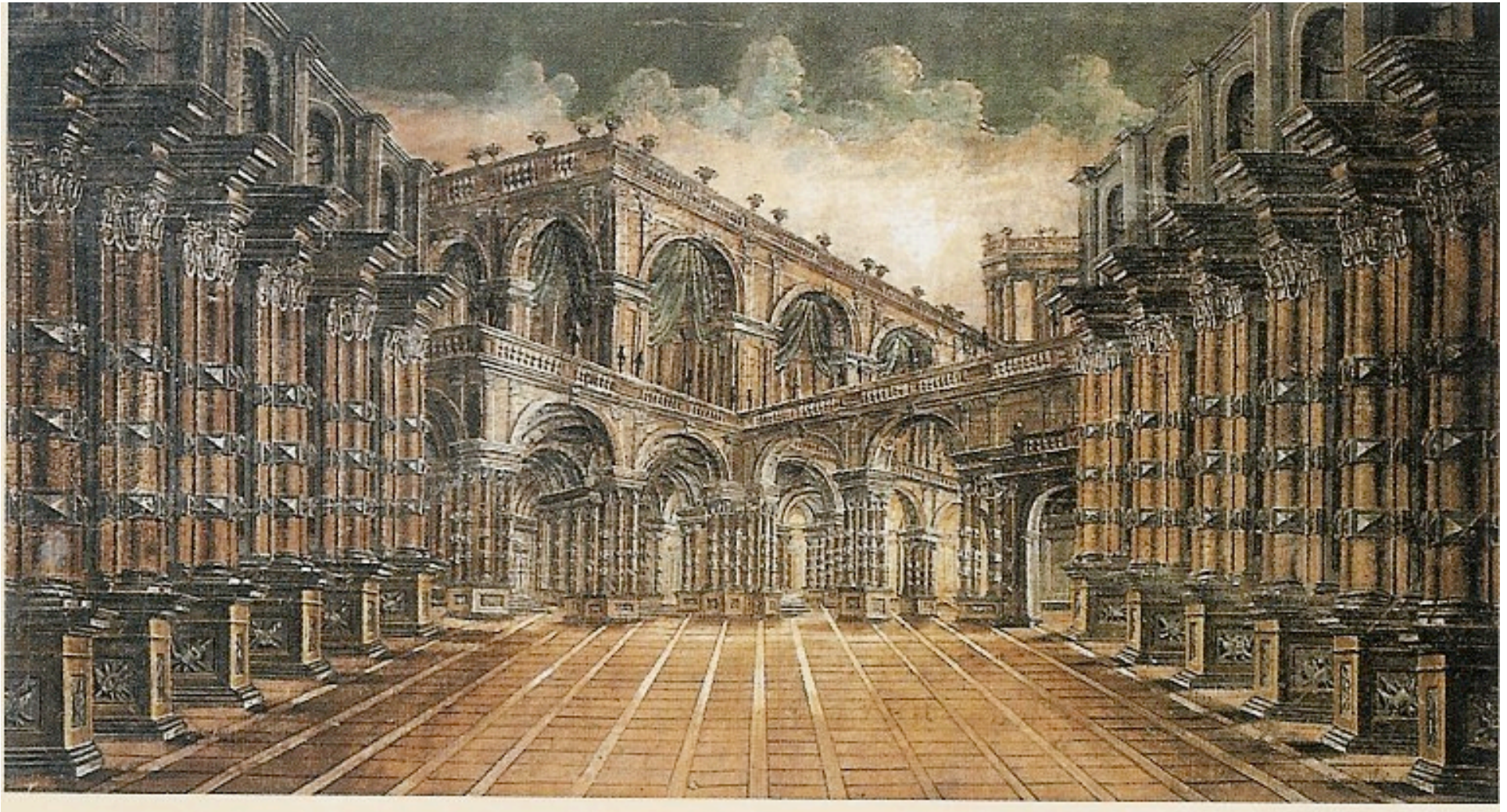

Ferdinando Bibiena prosp angolare

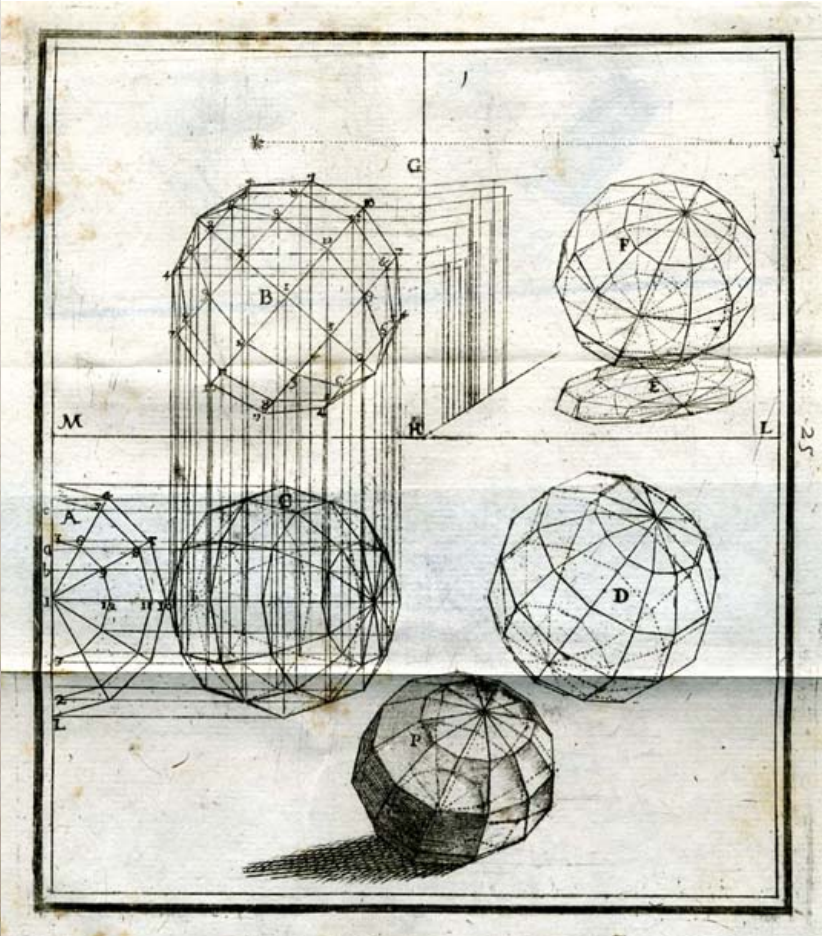
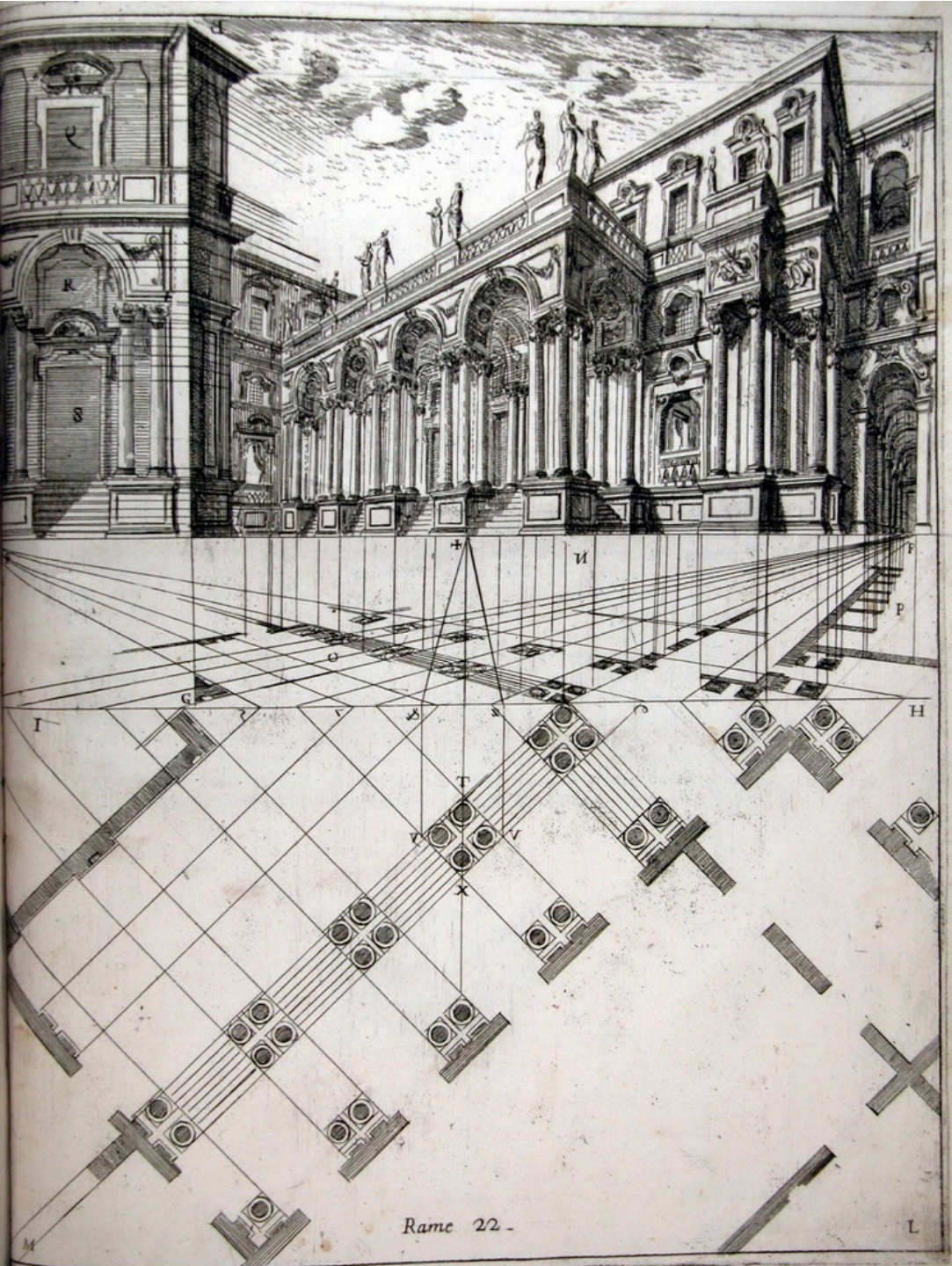

Poleni Vanvitelli, *La cupola vaticana*, Padova 1748

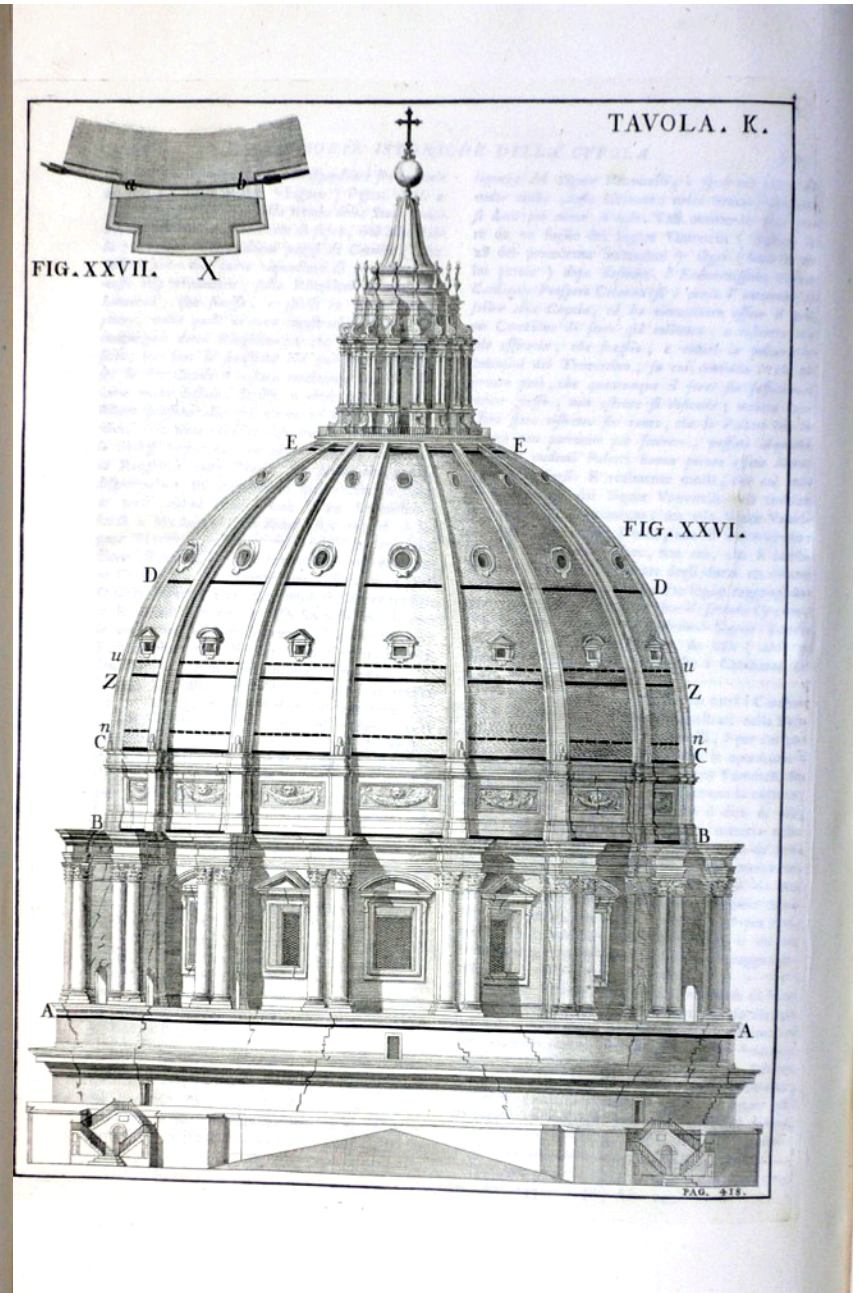
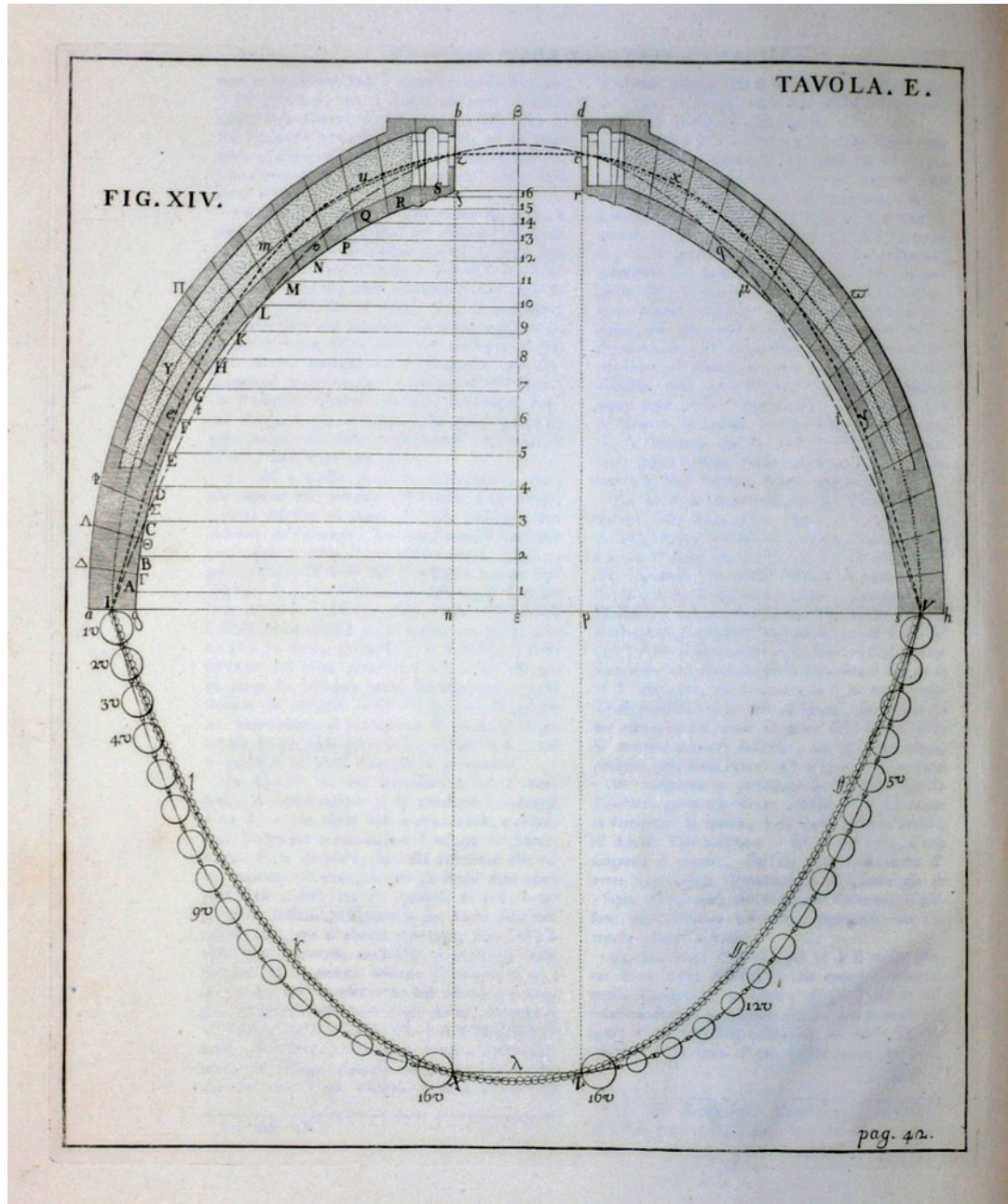

Paxton Christal palace London 1851

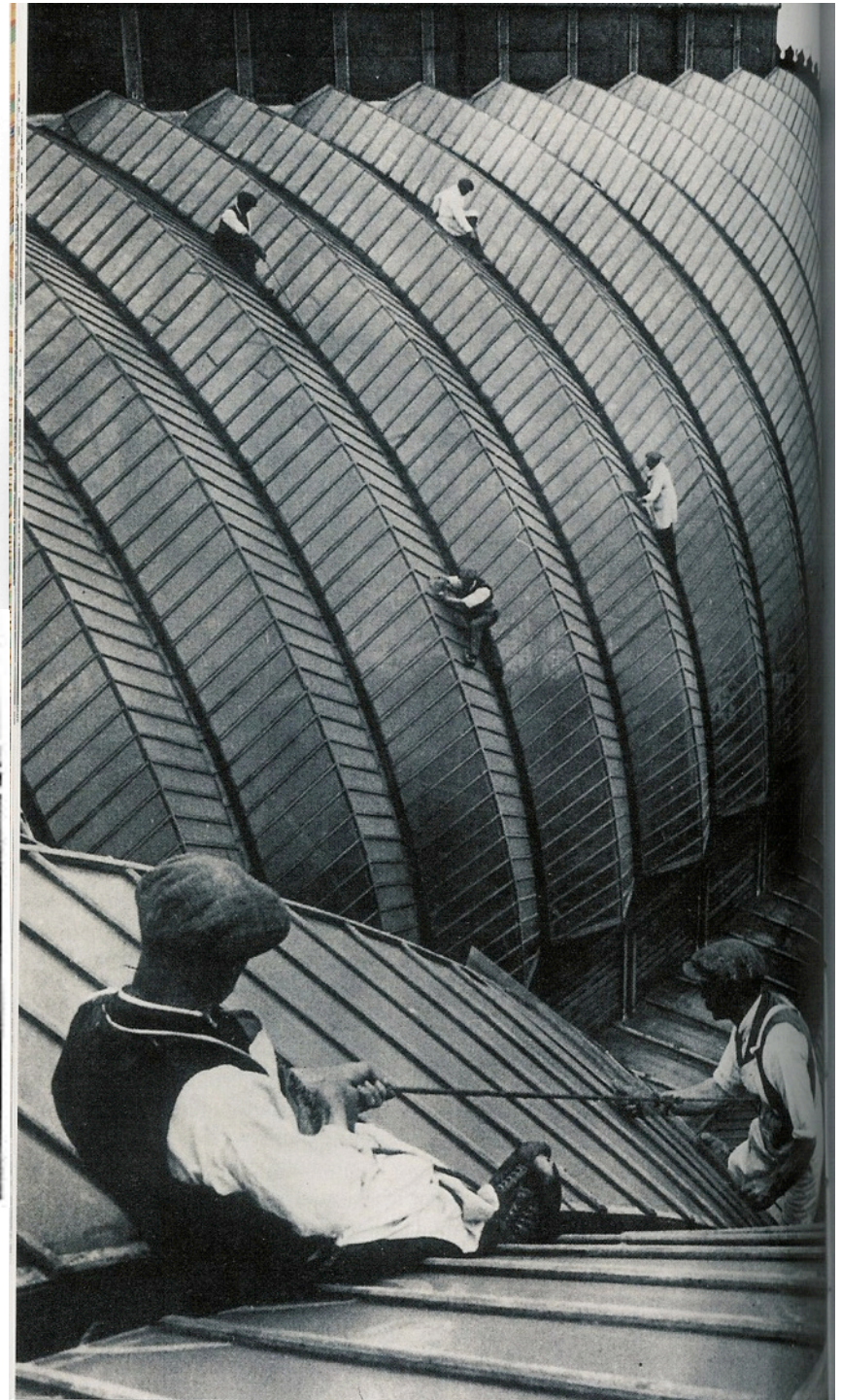
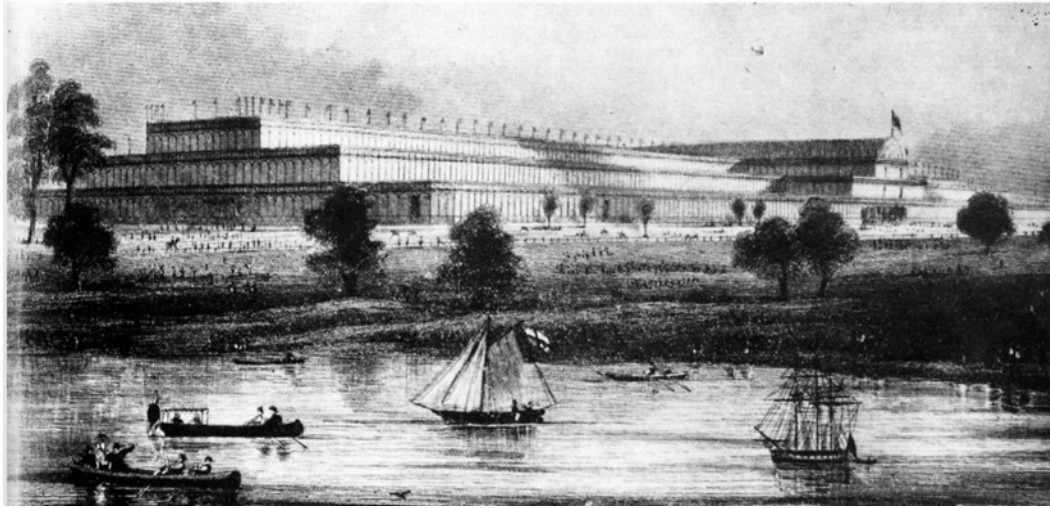

Paris 1867, 1889

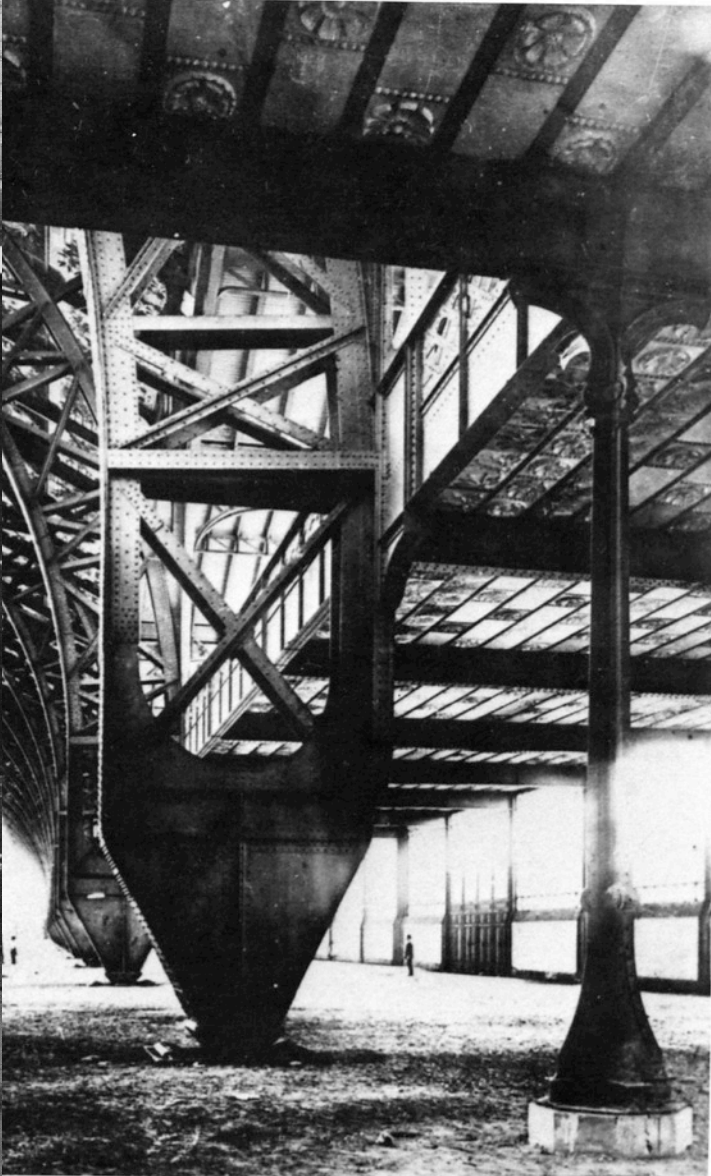
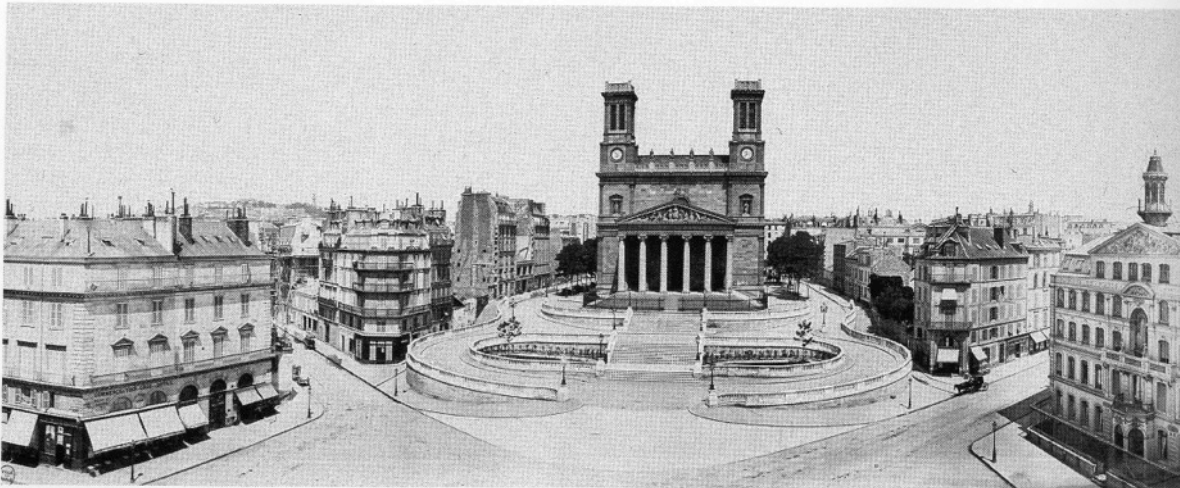

Burnham flatiron building NY 1902, Coburn Londra



J. R. S. S.

Tatlin monumento alla internazionale 1919-20,
El Lissinski grattacieli 1924, Larionov
internazionale 1927



Arch. EL. LISSITZKY.
661 - Progetto di grattacielo per Mosca - 1924 - Prospettiva.

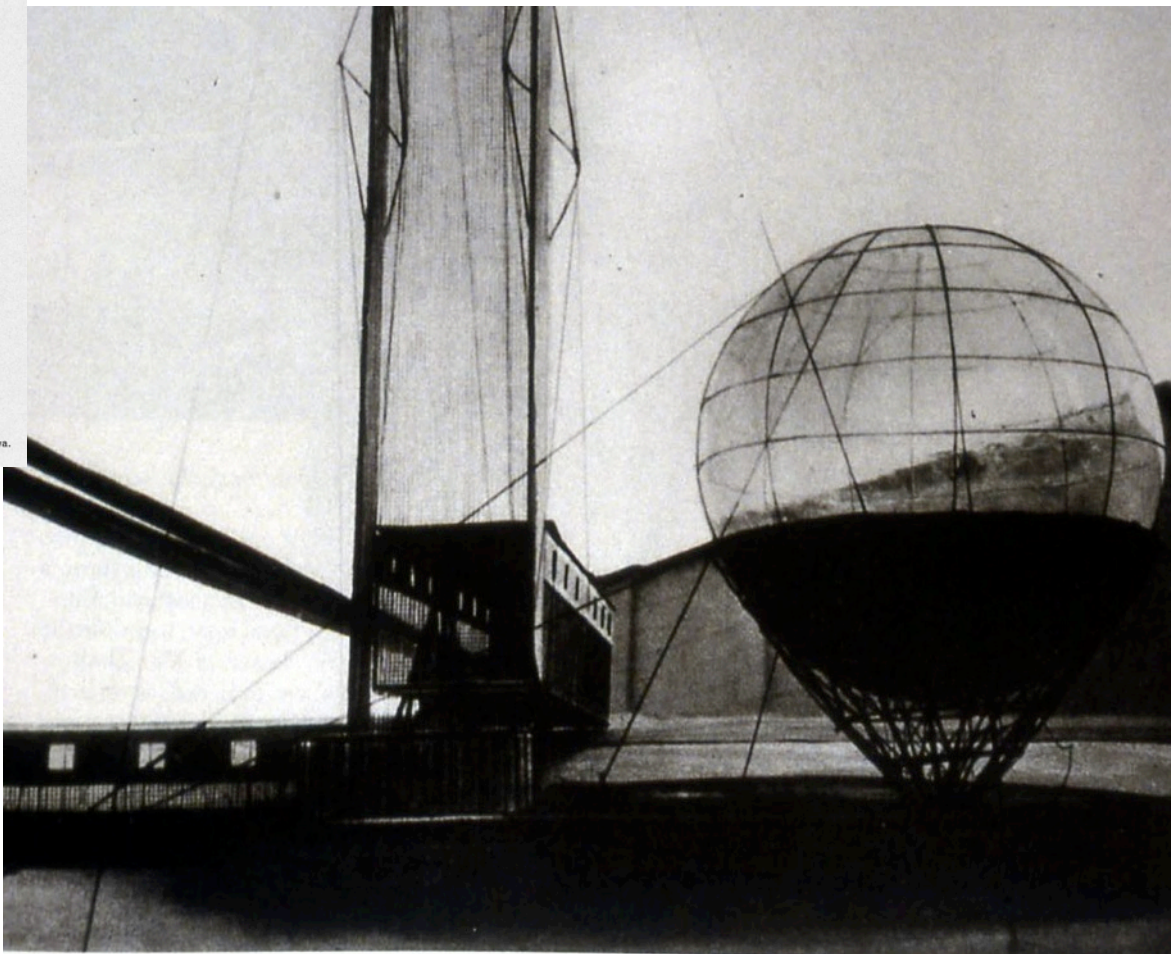
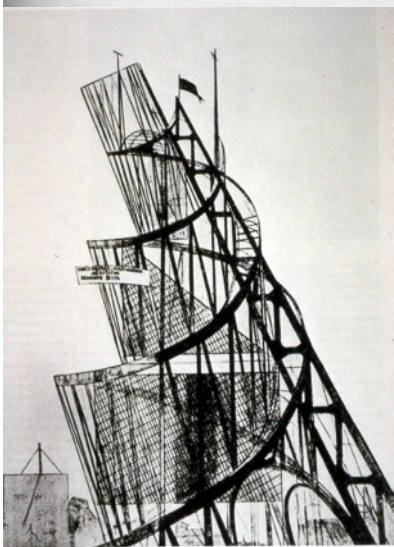



1928

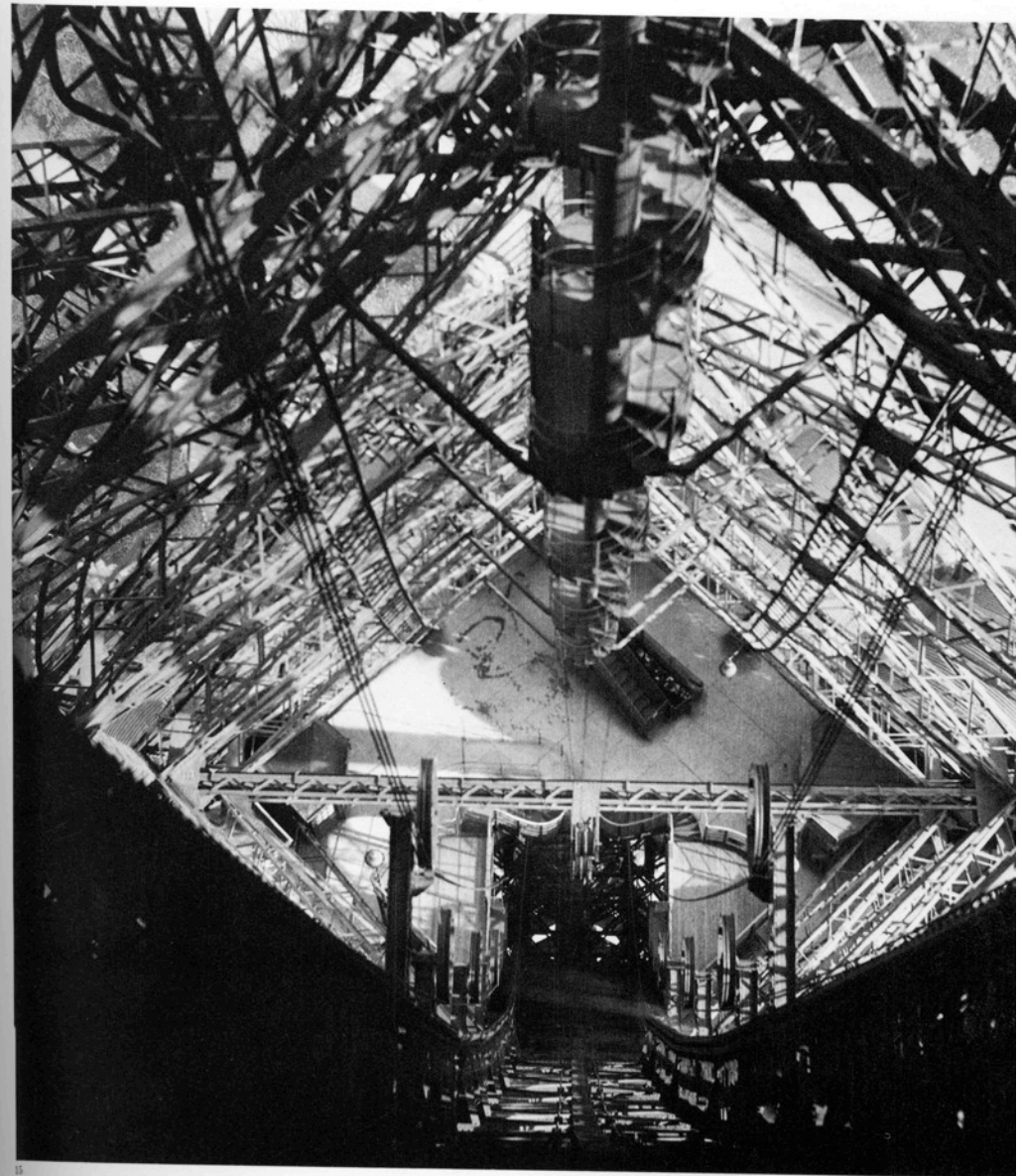

Lang metropolis 1926, Mendelson magazzini schocken stoccarda 1926

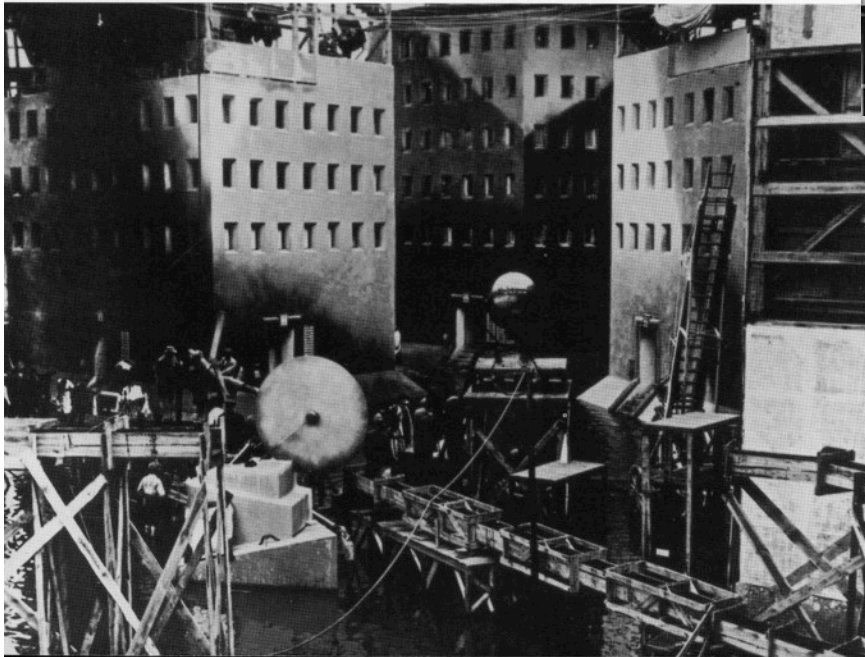
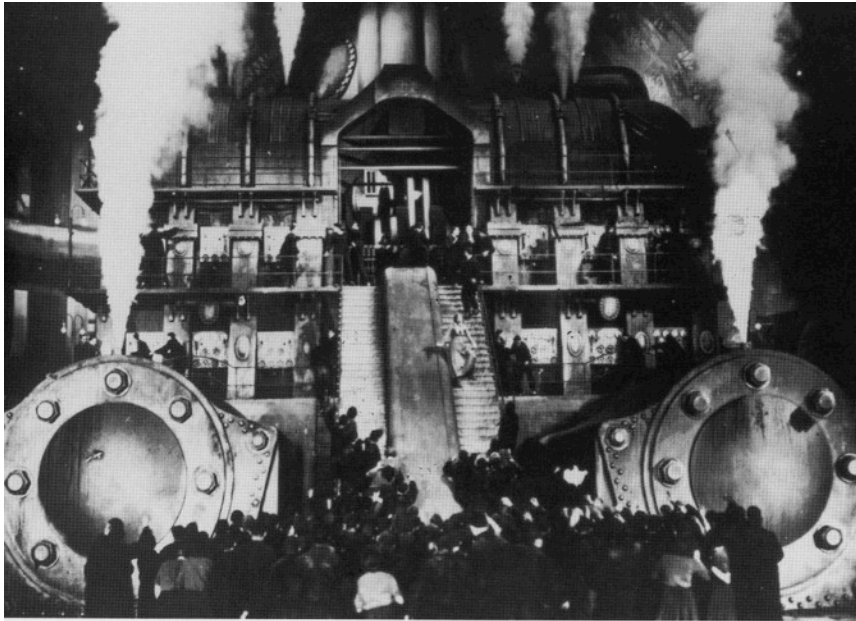

Le Corbusier ville Savoye 1929

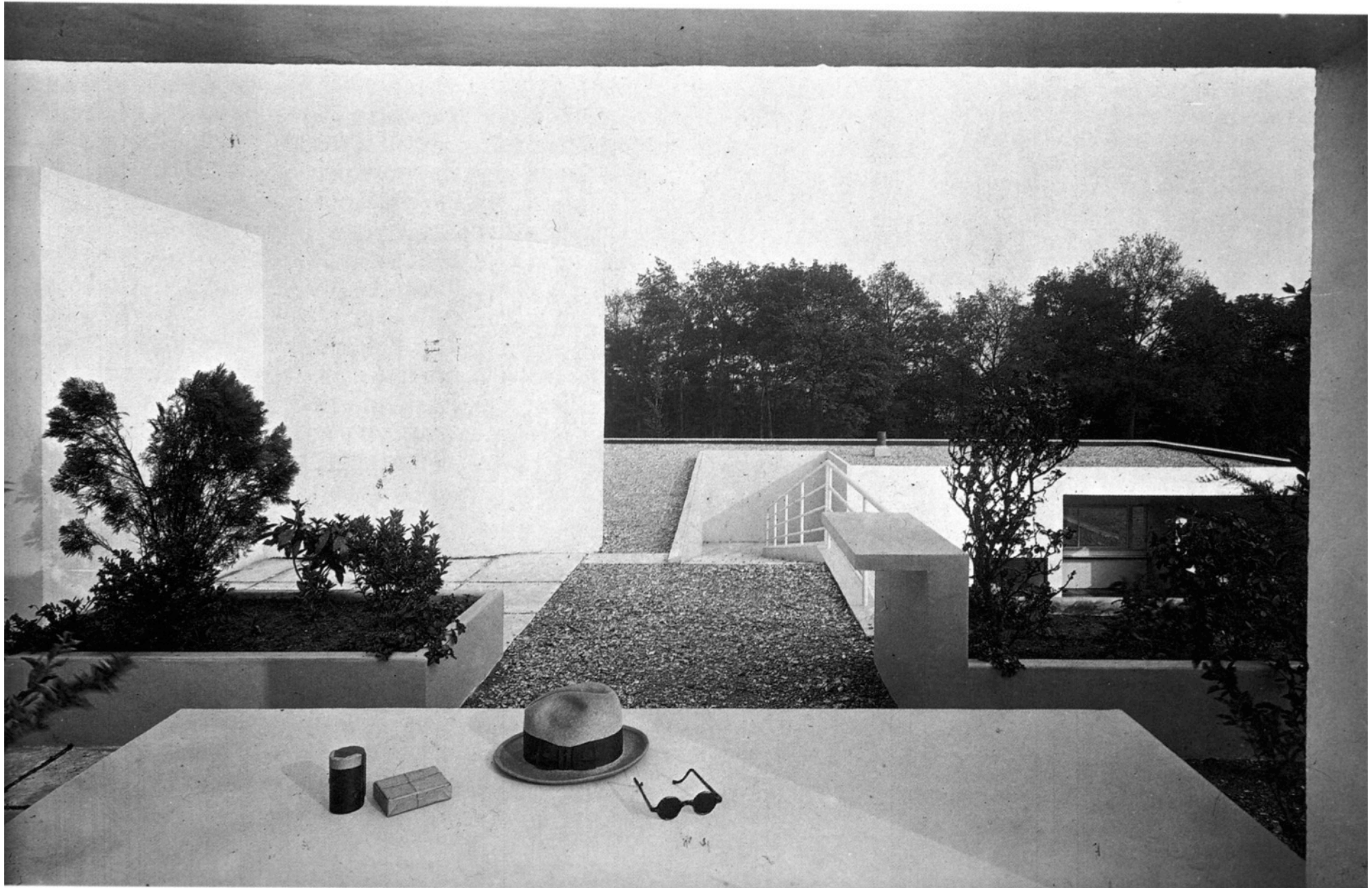



Terragni casa del fascio como
1932-34



OLANDA

Van Doesburg e Van Eestern assonometrie

di una casa 1922

Gropius e Meyer haus am horn 1923

weimar,

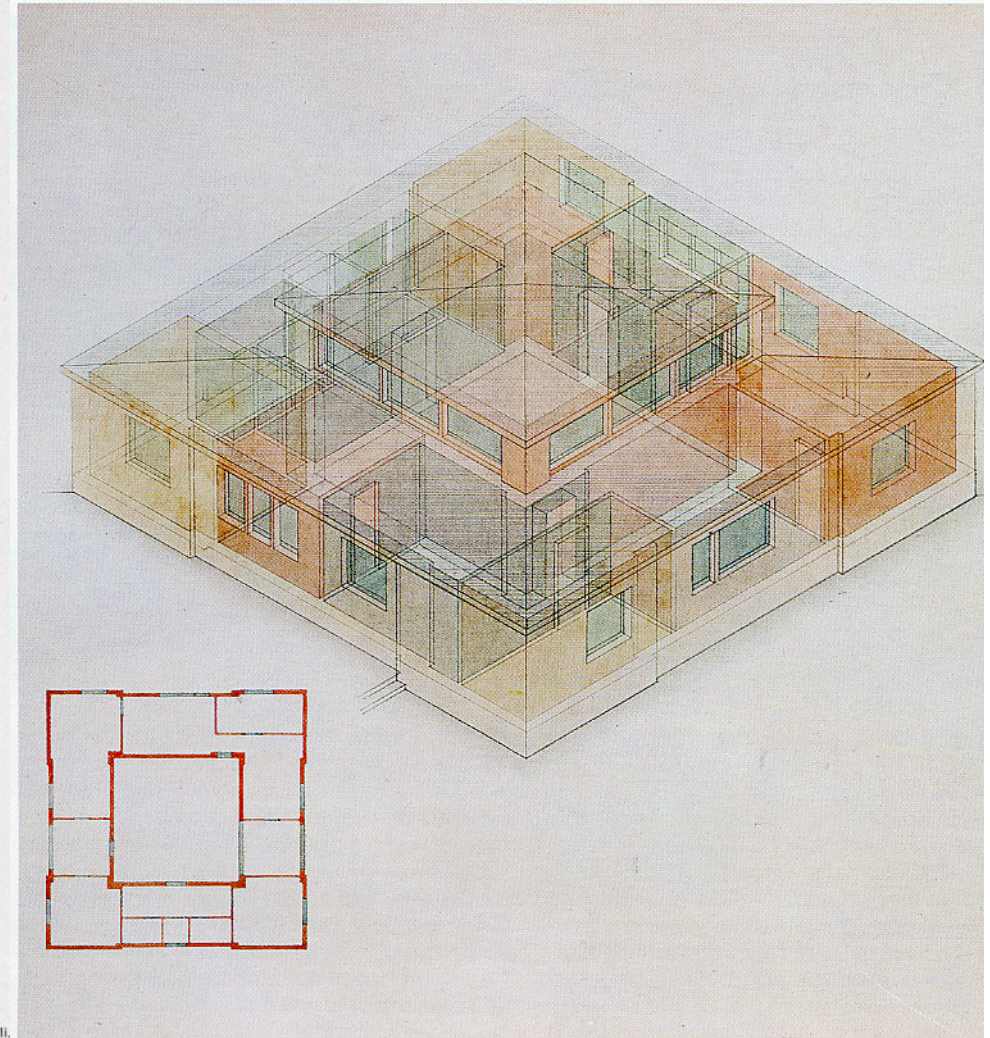
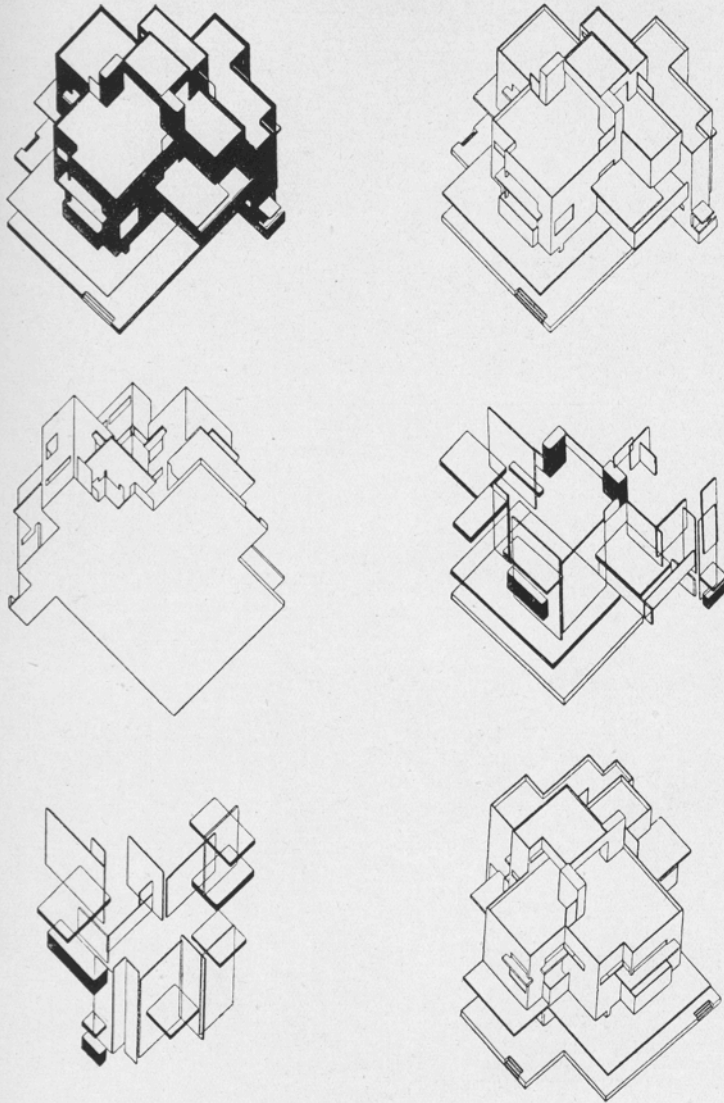

Arch. i THÉO VAN DOESBURG e CARL VAN EESTEREN.
466 - Progetto di una villa moderna a pianta trasformabile - 1922 - Assonometriche strutturali.

Mies van der rohe padiglione ted barcellona 1929

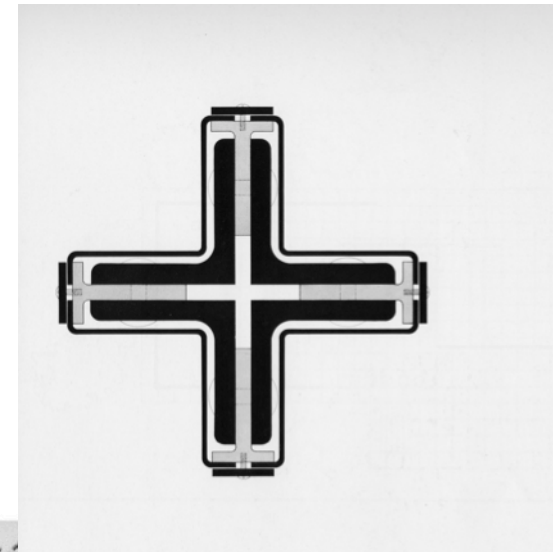

Il padiglione restò allestito per meno di un semestre; poi venne demolito e tutte le parti rivutilizzabili furono vendute. La fotografia mostra la ricostruzione fattane in seguito. Nel bacino del cortile circondato di marmo è esposto il nudo femminile "Il mattino", di Georg Kolbe.

Planta

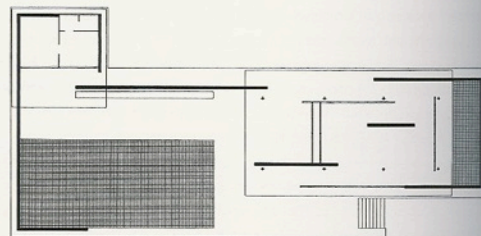

Mies van der Rohe MIT Chicago 1948-60 particolari costruttivi e prospettiva

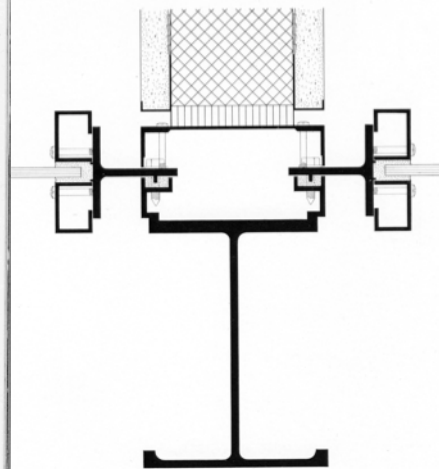
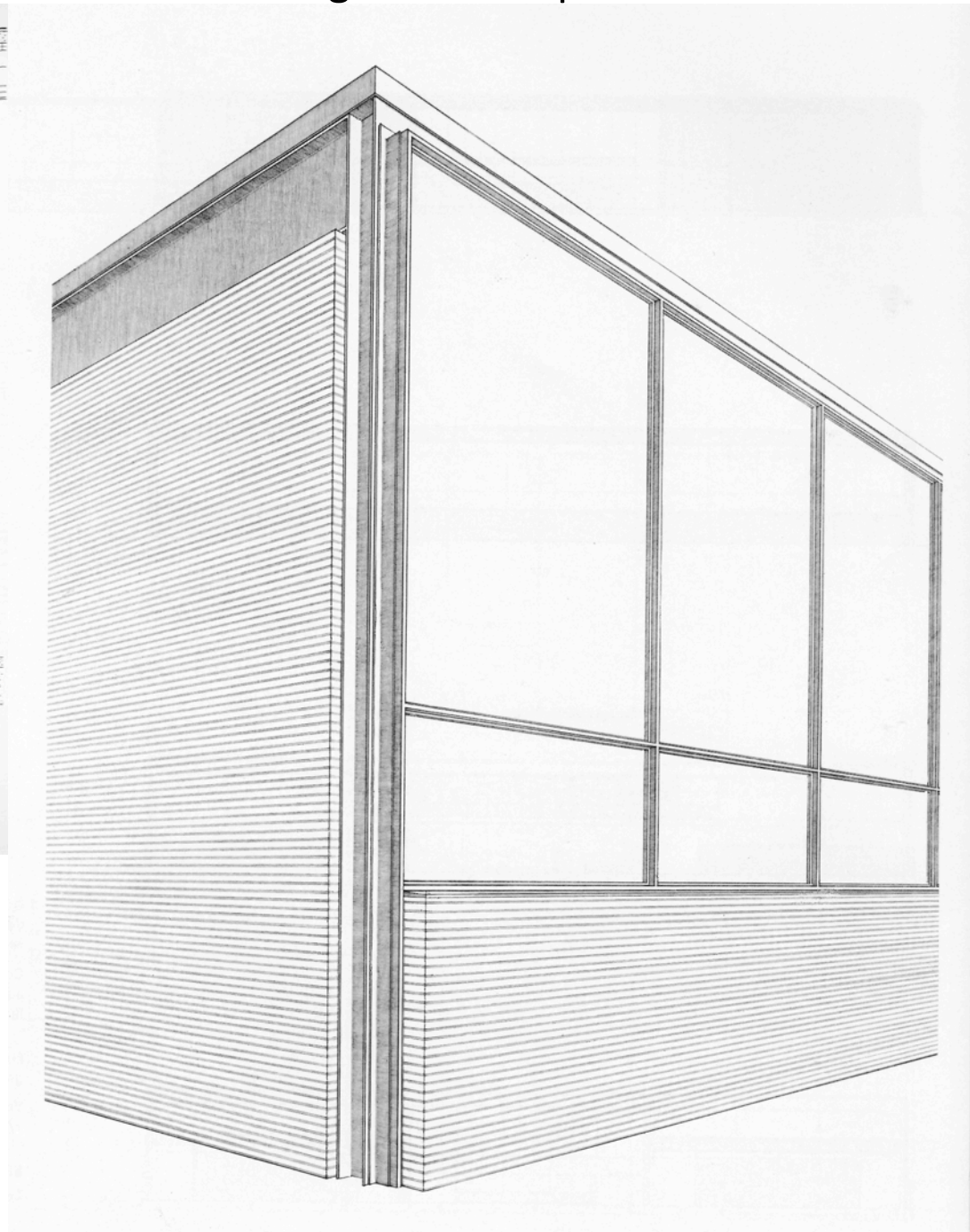
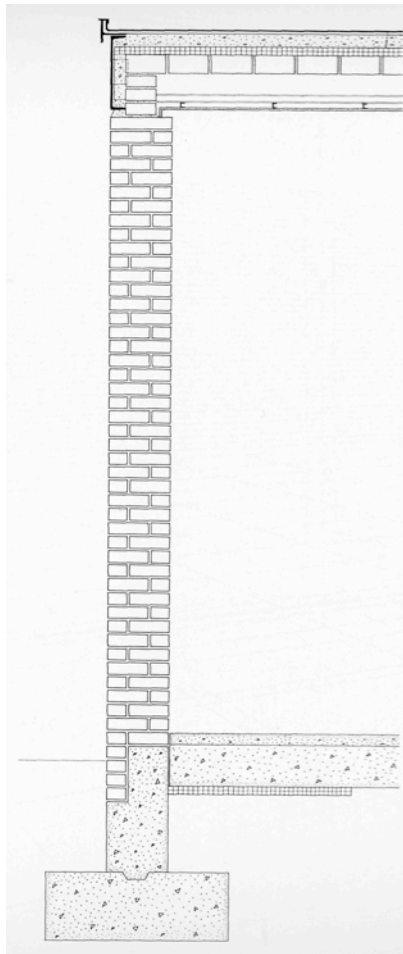

Ferdinando Bibbiena, Asymptote, museo del permafrost
Russia

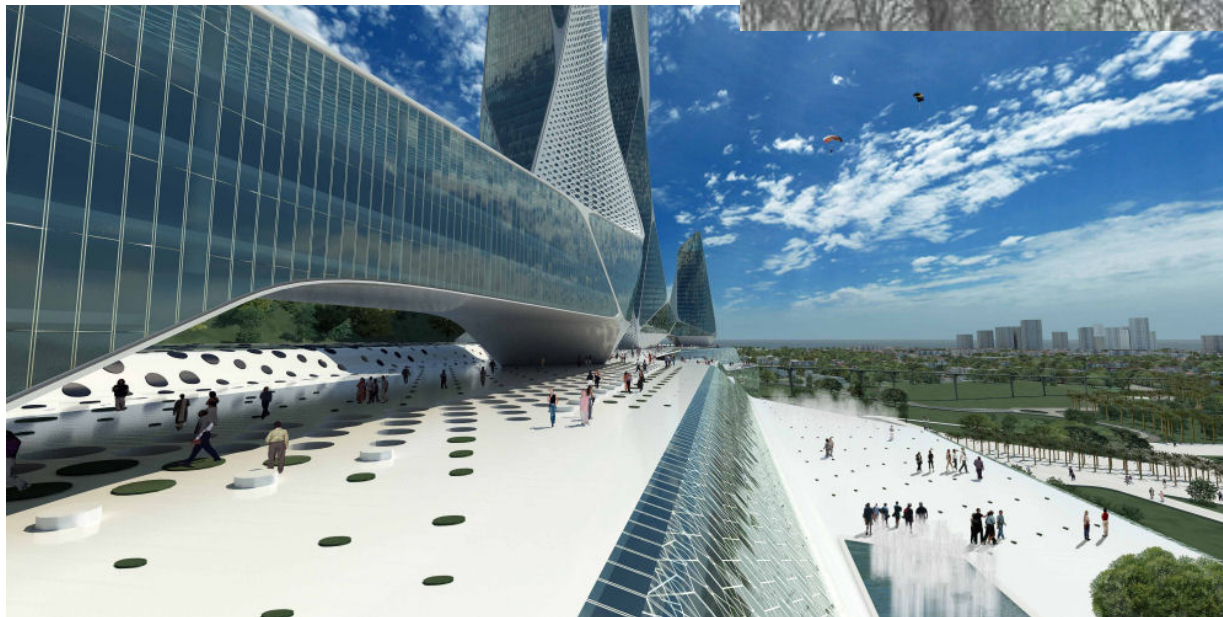

Asymdote, alzano s. paolo bg



Zaha Hadid maxi roma 1999-2009

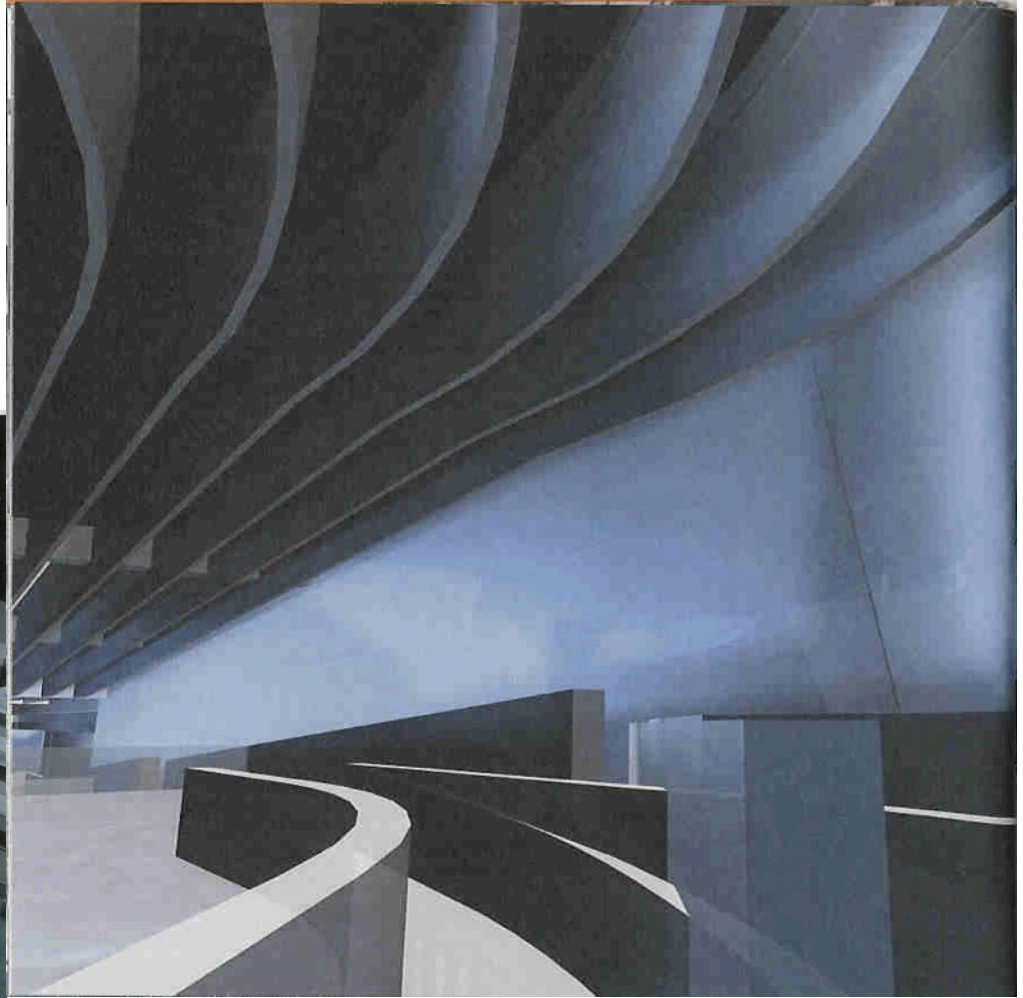
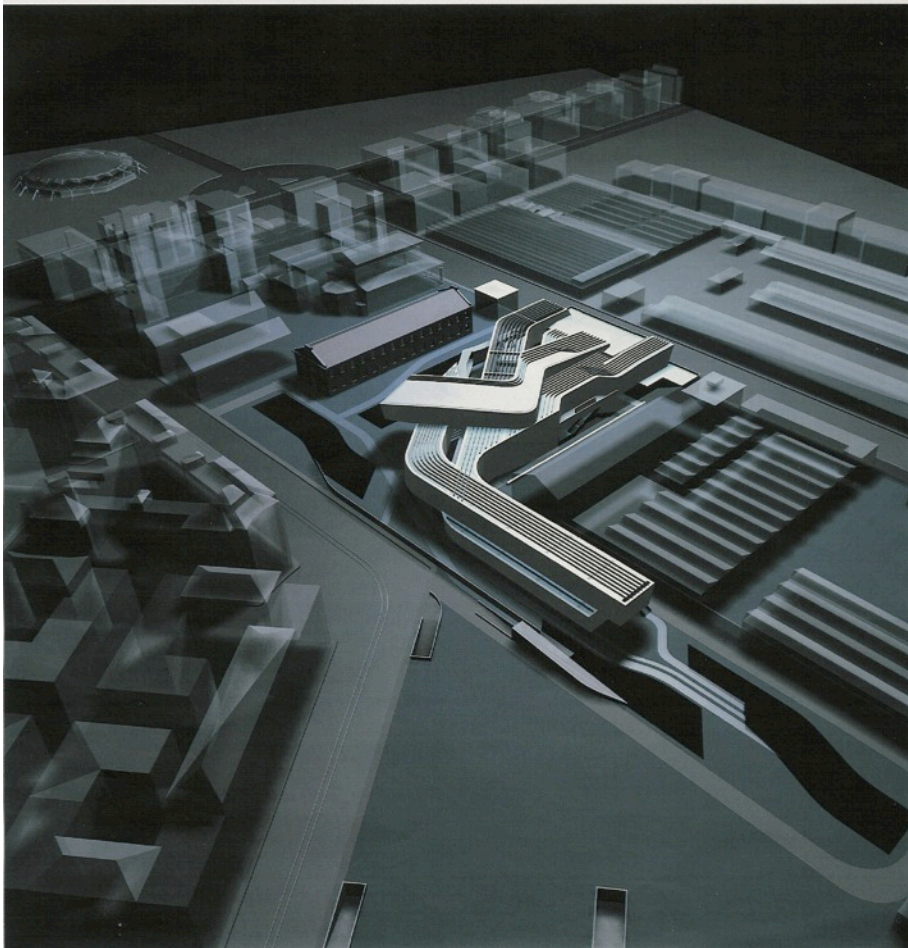

Scofidio Diller+Renfro Eyebeam ny 2001

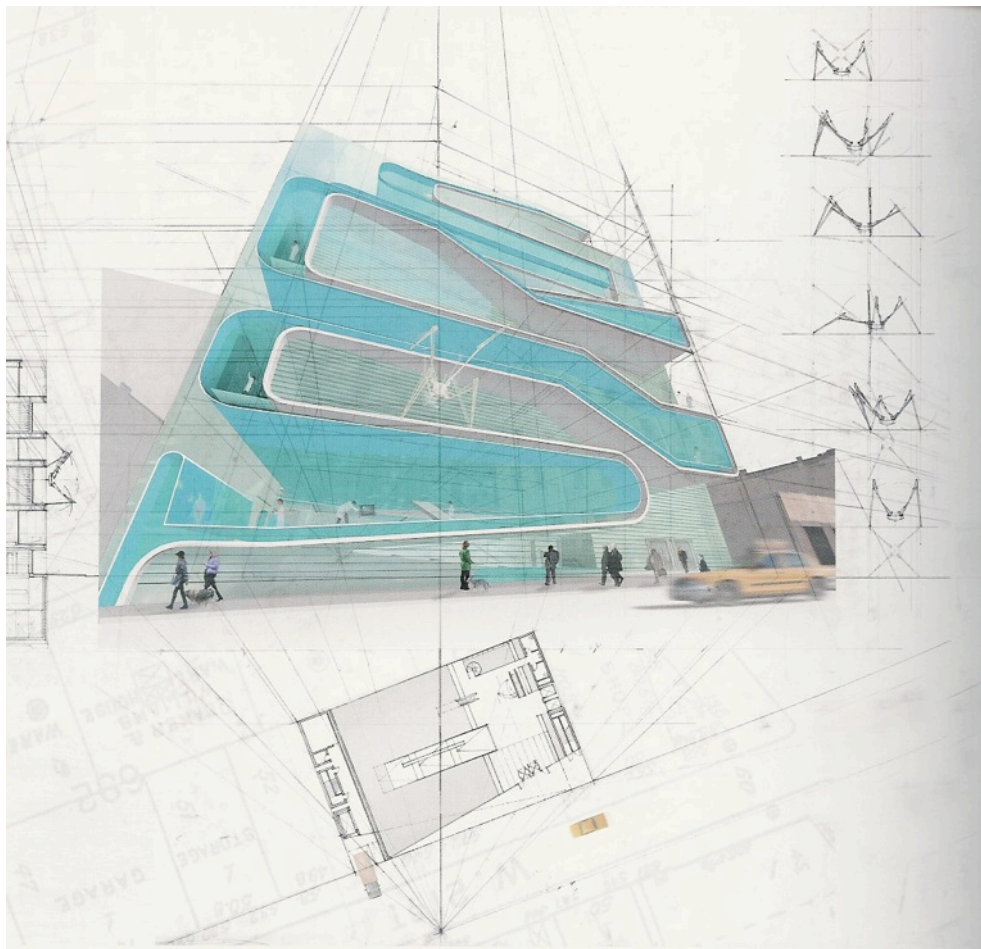

Scofidio Diller+Renfro Eyebeam ny 2001

