

# Baseband (3A)

---

Copyright (c) 2012 Young W. Lim.

Permission is granted to copy, distribute and/or modify this document under the terms of the GNU Free Documentation License, Version 1.2 or any later version published by the Free Software Foundation; with no Invariant Sections, no Front-Cover Texts, and no Back-Cover Texts. A copy of the license is included in the section entitled "GNU Free Documentation License".

Please send corrections (or suggestions) to [youngwlim@hotmail.com](mailto:youngwlim@hotmail.com).

This document was produced by using OpenOffice and Octave.

# Pulse & Waveform

---

## Bit Time Slot

## Codeword Time Slot

## Bits / PCM Word

L : number of quantization levels       $L = 2^l$

## Bits / Symbol

M: size of a set of message symbols       $M = 2^k$

# M-ary Pulse Modulation Waveforms

---

**PAM** (Pulse Amplitude Modulation)

**PPM** (Pulse Position Modulation)

**PDM** (Pulse Duration Modulation)

**PWM** (Pulse Width Modulation)

M-ary Pulse Modulation      M-ary alphabet set

**M-ary PAM** : M allowable amplitude levels are assigned to each of the M possible symbol values.

# PAM

The amplitude of transmitted pulses is varied in a discrete manner in accordance with an input stream of digital data

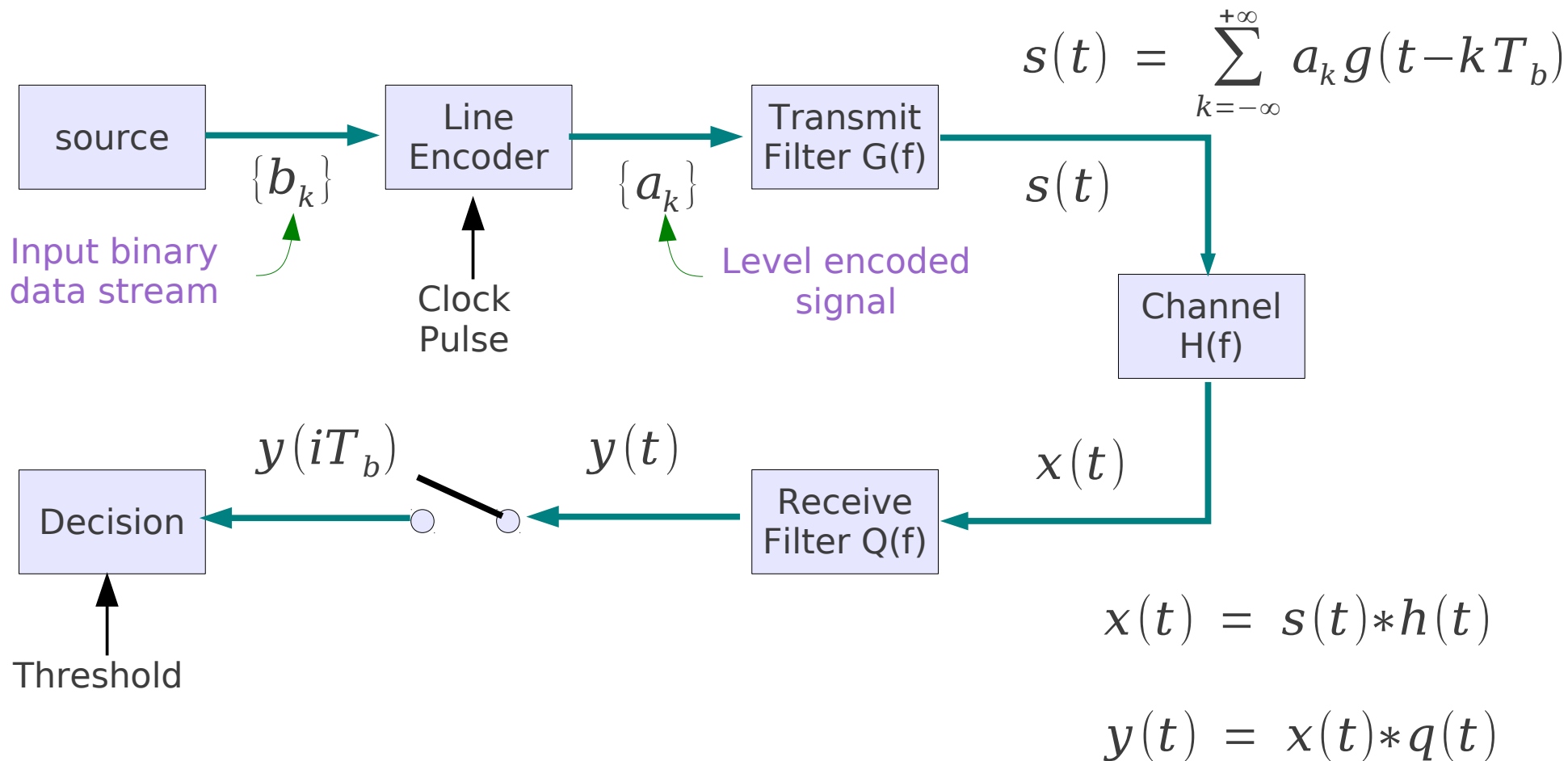

# M-ary PAM

The amplitude of transmitted pulses is varied in a discrete manner in accordance with an input stream of digital data

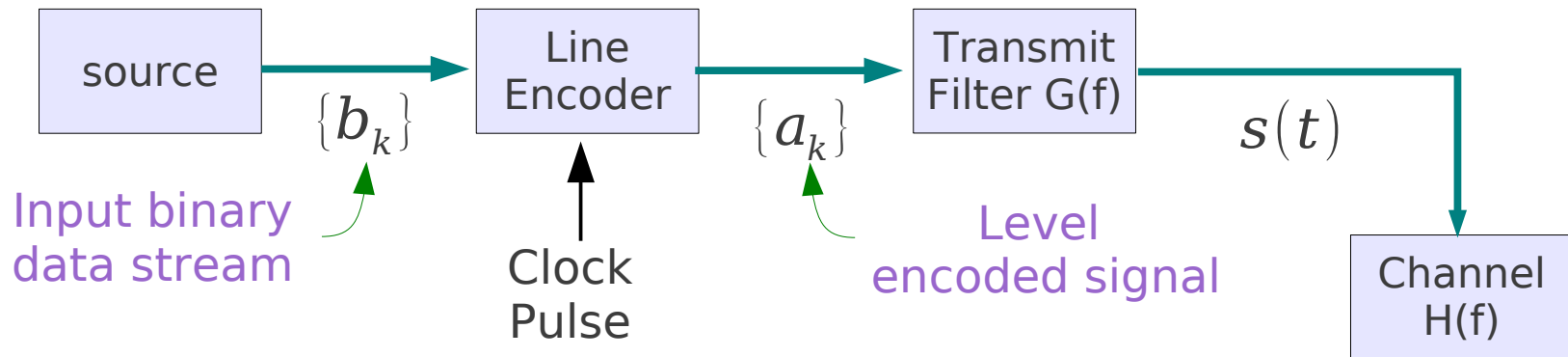

M-ary PAM Bit Rate

$$T = T_b \log_2 M$$

M possible amplitude level ( $M > 2$ )  
M symbols  
Transmits sequence of symbols

T: Symbol duration  
 $1/T$  : Symbol rate

Binary PAM  
 $T_b$  : Bit duration  
 $1/T_b$  : Bit rate

# Inter-Symbol Interference

distortion of a signal  
in which one symbol interferes with subsequent symbols.  
multipath propagation  
inherent non-linear filter → long tail, smear, blur ...

- adaptive equalization
- error correcting codes

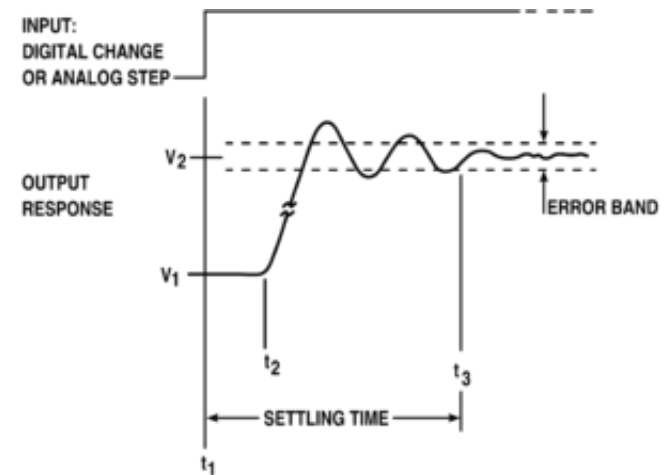
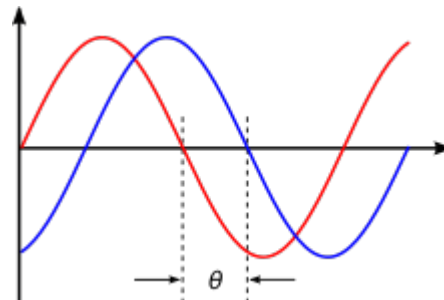
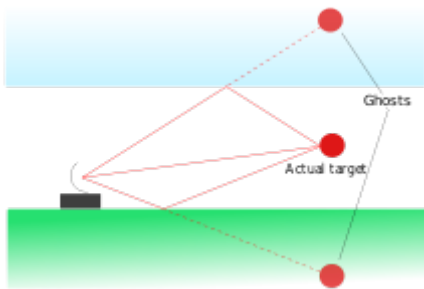

# Pulse Shaping

Changing the waveform of transmitted p  
Bandwidth constraints  
Control ISI (inter-Symbol Interference)

- Sinc Filter
- Raised Cosine Filter
- Gaussian Filter

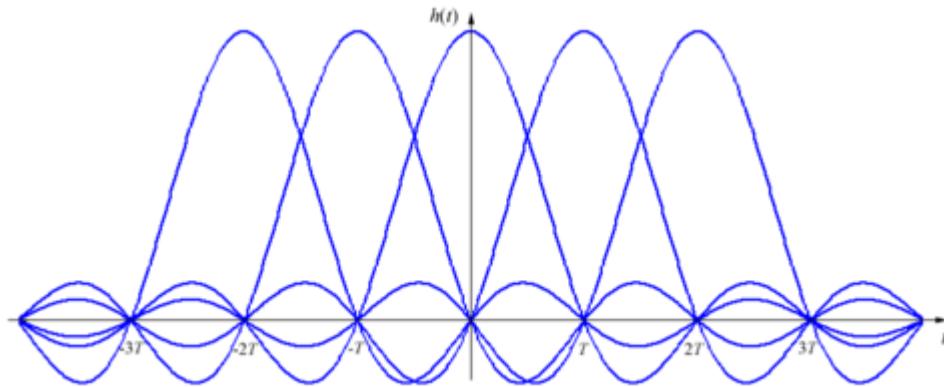
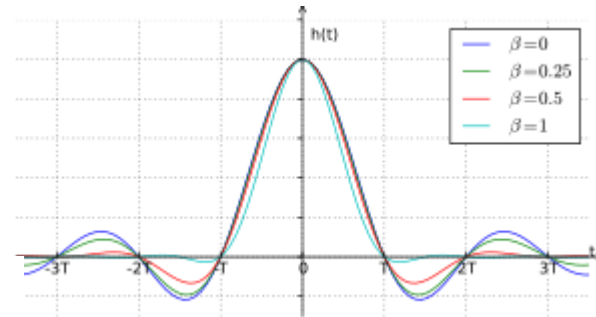
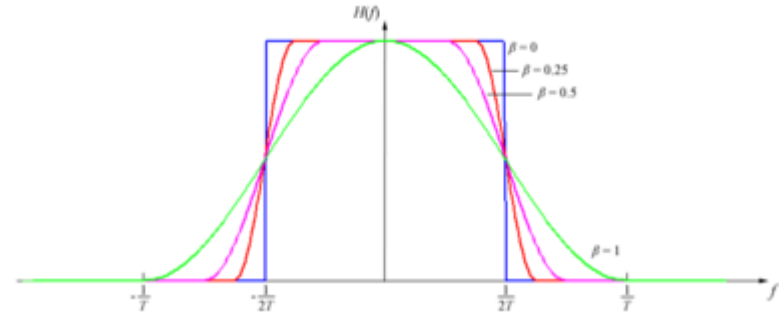



# Signal Space

N-dim orthogonal space

Characterized by a set of N linearly independent functions

Basis functions  $\Psi_j(t)$

Independent  $\rightarrow$  not interfering in detection

$$\int_0^T \Psi_j(t) \Psi_k(t) dt = K_j \delta_{jk} \quad 0 \leq t \leq T \quad j, k = 1, \dots, N$$

Kronecker delta  
functions

$$\delta_{jk} = \begin{cases} 1 & \text{for } j = k \\ 0 & \text{otherwise} \end{cases}$$

N-dim orthonormal space

$$K_j = 1$$

$$E_j = \int_0^T \Psi_j^2(t) dt = K_j$$

# Linear Combination

Any finite set of waveform  $\{s_i(t)\} \quad i = 1, \dots, M$

Characterized by a set of  $N$  linearly independent functions

$$\begin{aligned} s_1(t) &= a_{11} \Psi_1(t) + a_{12} \Psi_2(t) + \dots + a_{1N} \Psi_N(t) \\ s_2(t) &= a_{21} \Psi_1(t) + a_{22} \Psi_2(t) + \dots + a_{2N} \Psi_N(t) \\ &\vdots \\ s_M(t) &= a_{M1} \Psi_1(t) + a_{M2} \Psi_2(t) + \dots + a_{MN} \Psi_N(t) \end{aligned}$$

$$s_i(t) = \sum_{j=1}^N a_{ij} \Psi_j(t) \quad i = 1, \dots, M$$
$$N \leq M$$

# Linear Combination

Any finite set of waveform  $\{s_i(t)\}$   $i = 1, \dots, M$

Characterized by a set of  $N$  linearly independent functions

$$s_i(t) = \sum_{j=1}^N a_{ij} \Psi_j(t) \quad i = 1, \dots, M$$
$$N \leq M$$

$$a_{ij} = \frac{1}{K_j} \int_0^T s_i(t) \Psi_j(t) dt \quad i = 1, \dots, M \quad 0 \leq t \leq T$$
$$j = 1, \dots, N$$

$$\{s_i(t)\} \longleftrightarrow \{\mathbf{s}_i\} = \{a_{i1}, a_{i2}, \dots, a_{iN}\} \quad i = 1, \dots, M$$

# Signals and Noise

Any finite set of waveform  $\{s_i(t)\} \quad i = 1, \dots, M$

Characterized by a set of  $N$  linearly independent functions

$$\{s_i(t)\} \longleftrightarrow \{\mathbf{s}_i\} = \{a_{i1}, a_{i2}, \dots, a_{iN}\} \quad i = 1, \dots, M$$

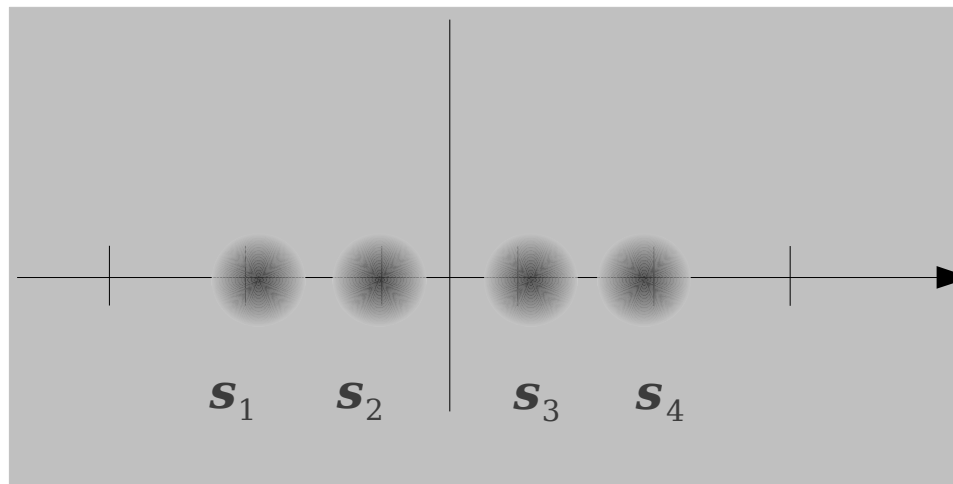

4-ary PAM

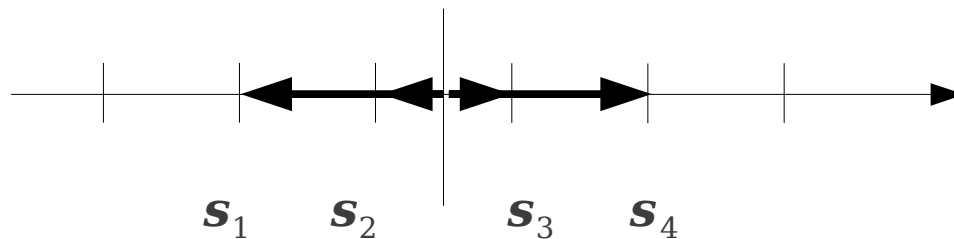

# Detection of Binary Signals

## Transmitted Signal

$$s_i(t) = \begin{cases} s_1(t) & 0 \leq t \leq T \quad \text{for a binary 1} \\ s_2(t) & 0 \leq t \leq T \quad \text{for a binary 0} \end{cases}$$

## Received Signal

$$r(t) = s_i(t) + n(t) \quad i = 1, 2; \quad 0 \leq t \leq T$$

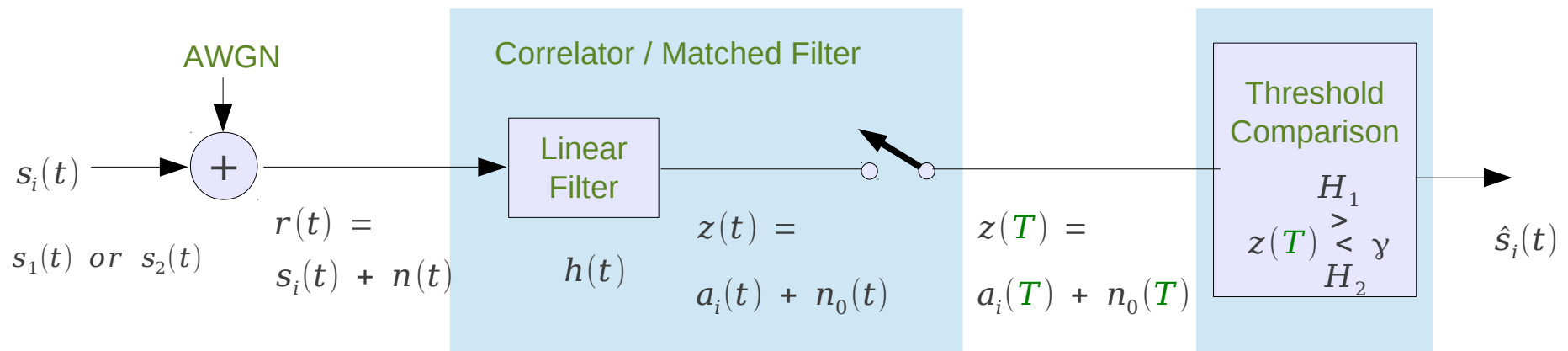

# Detection of Binary Signals

$$z(T) = a_i(T) + n_0(T) \quad \Rightarrow \quad z = a_i + n_0$$

$$p(n_0) = \frac{1}{\sigma_0 \sqrt{2\pi}} \exp\left[-\frac{1}{2} \left(\frac{n_0}{\sigma_0}\right)^2\right]$$

$$p(z|s_1) = \frac{1}{\sigma_0 \sqrt{2\pi}} \exp\left[-\frac{1}{2} \left(\frac{z-a_1}{\sigma_0}\right)^2\right]$$

$$p(z|s_2) = \frac{1}{\sigma_0 \sqrt{2\pi}} \exp\left[-\frac{1}{2} \left(\frac{z-a_2}{\sigma_0}\right)^2\right]$$

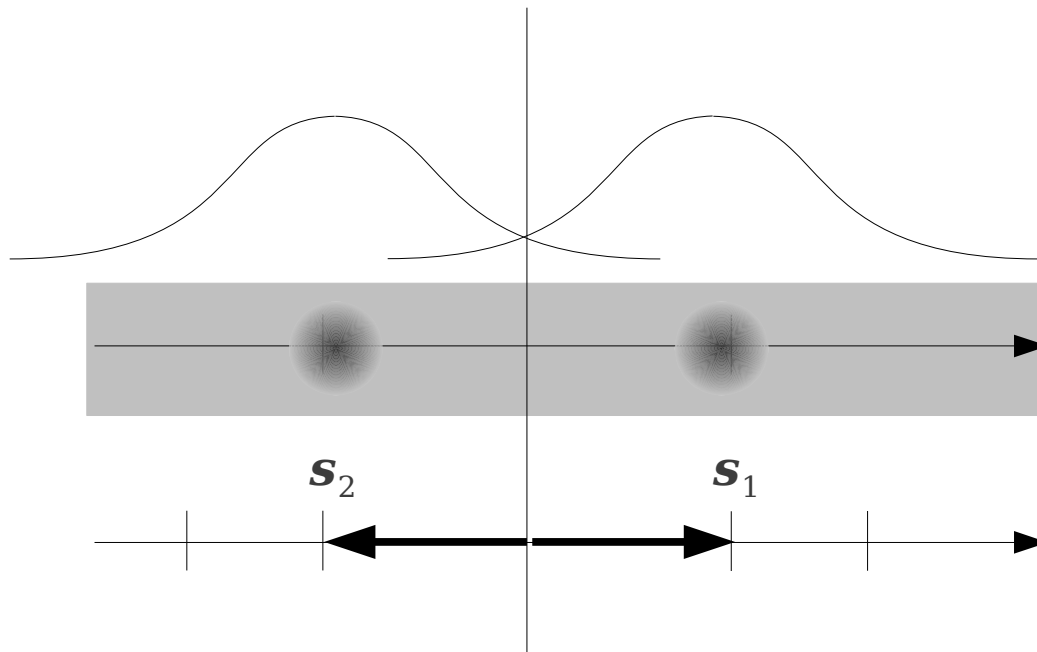

$$\begin{matrix} H_1 \\ z(T) > \gamma \\ H_2 \end{matrix}$$

$$\begin{matrix} H_1 \\ \frac{p(z|s_1)}{p(z|s_2)} > \frac{P(s_2)}{P(s_1)} \\ H_2 \end{matrix}$$

$$\begin{matrix} H_1 \\ \frac{p(z|s_1)}{p(z|s_2)} > \frac{a_1+a_2}{2} = \gamma_0 \\ H_2 \end{matrix}$$

# Error Probability

error  $e$

$$p(e|s_1) = p(H_2|s_1) = \int_{-\infty}^{y_0} p(z|s_1) dz$$

$$p(e|s_2) = p(H_1|s_2) = \int_{y_0}^{-\infty} p(z|s_2) dz$$

probability of bit error  $P_B$

$$\begin{aligned} P_B &= P(e|s_1)P(s_1) + P(e|s_2)P(s_2) \\ &= P(H_2|s_1)P(s_1) + P(H_1|s_2)P(s_2) \end{aligned}$$

equal a priori probabilities

$$\begin{aligned} P_B &= \frac{1}{2}P(H_2|s_1) + \frac{1}{2}P(H_1|s_2) \\ &= P(H_2|s_1) = P(H_1|s_2) \end{aligned}$$

$$\begin{aligned} P_B &= \int_{y_0=(a_1+a_2)/2}^{+\infty} p(z|s_2) dz \\ &= \int_{y_0=(a_1+a_2)/2}^{+\infty} \frac{1}{\sigma_0\sqrt{2\pi}} \exp\left[-\frac{1}{2}\left(\frac{z-a_2}{\sigma_0}\right)^2\right] dz \end{aligned}$$

$$u = (z - a_2)/\sigma_0 \quad \sigma_0 du = dz$$

$$= \int_{u=(a_1-a_2)/2\sigma_0}^{+\infty} \frac{1}{\sqrt{2\pi}} \exp\left(\frac{-u^2}{2}\right) du$$

$$= Q\left(\frac{a_1 - a_2}{2\sigma_0}\right)$$

complementary error function  
(co-error function)

$$Q(x) = \int_x^{+\infty} \frac{1}{\sqrt{2\pi}} \exp\left(\frac{-x^2}{2}\right) dx$$





# Maximum Likelihood Receiver

## maximum likelihood detector

$P(s_1) = P(s_2)$  equal a priori probability

$p(z|s_1), p(z|s_2)$  symmetric likelihood

→  $\gamma_0 = \frac{(a_1 + a_2)}{2}$  optimum threshold for minimizing the error probability

→ select the hypothesis with the maximum likelihood

## complementary error function

$$Q(x) = \int_x^{+\infty} \frac{1}{\sqrt{2\pi}} \exp\left(-\frac{u^2}{2}\right) du$$

$$P_B = \int_{\gamma_0 = (a_1 - a_2)/2\sigma_0}^{+\infty} \frac{1}{\sqrt{2\pi}} \exp\left(-\frac{u^2}{2}\right) du$$

$$= Q\left(\frac{a_1 - a_2}{2\sigma_0}\right)$$

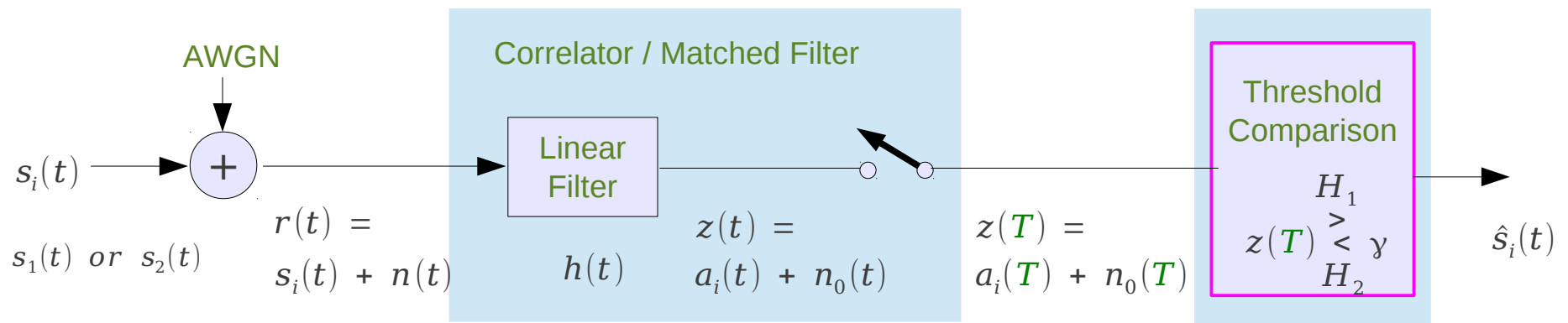
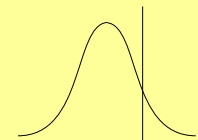

# Matched Filter Minimizes $P_B$ by Maximizing SNR

## Matched Filter / Correlator

maximize  $\frac{(a_1 - a_2)^2}{\sigma_0^2}$   $\rightarrow$  minimize  
 maximize  $\frac{(a_1 - a_2)^2}{2\sigma_0}$   $\rightarrow$   $P_B = Q\left(\frac{a_1 - a_2}{2\sigma_0}\right)$   
 maximize  $\left(\frac{S}{N}\right)_T = \frac{a_i^2}{\sigma_0^2}$   $\max\left(\frac{S}{N}\right)_T = \frac{2E}{N_0}$   
 matched to  $s_1 - s_2$   
 $\left(\frac{S}{N}\right)_T = \frac{a_1 - a_2^2}{\sigma_0^2} = \frac{2E_d}{N_0}$

complementary error function

$$Q(x) = \int_x^{+\infty} \frac{1}{\sqrt{2\pi}} \exp\left(-\frac{u^2}{2}\right) du$$

$$P_B = \int_{\gamma_0 = (a_1 - a_2)/2\sigma_0}^{+\infty} \frac{1}{\sqrt{2\pi}} \exp\left(-\frac{u^2}{2}\right) du$$

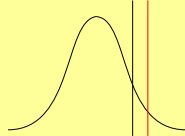
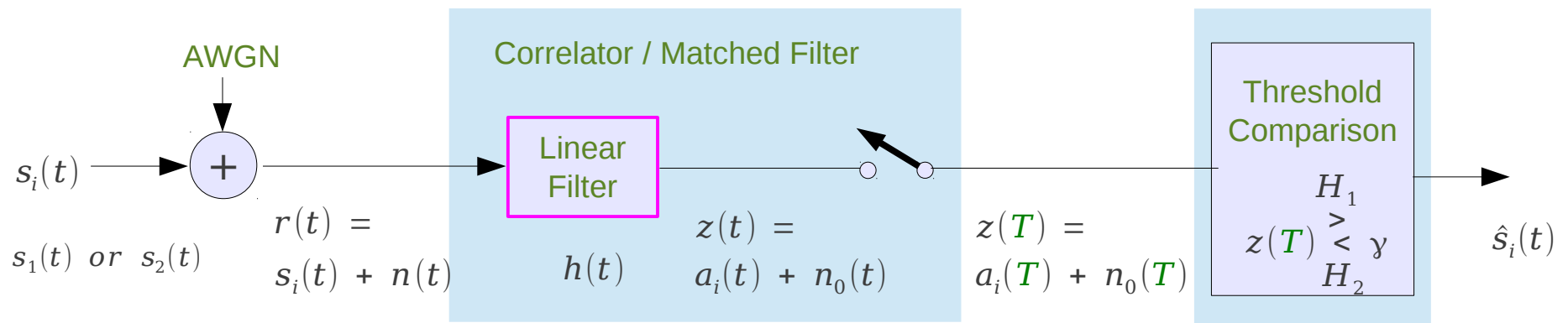
$$= Q\left(\frac{E_d}{2N_0}\right)$$

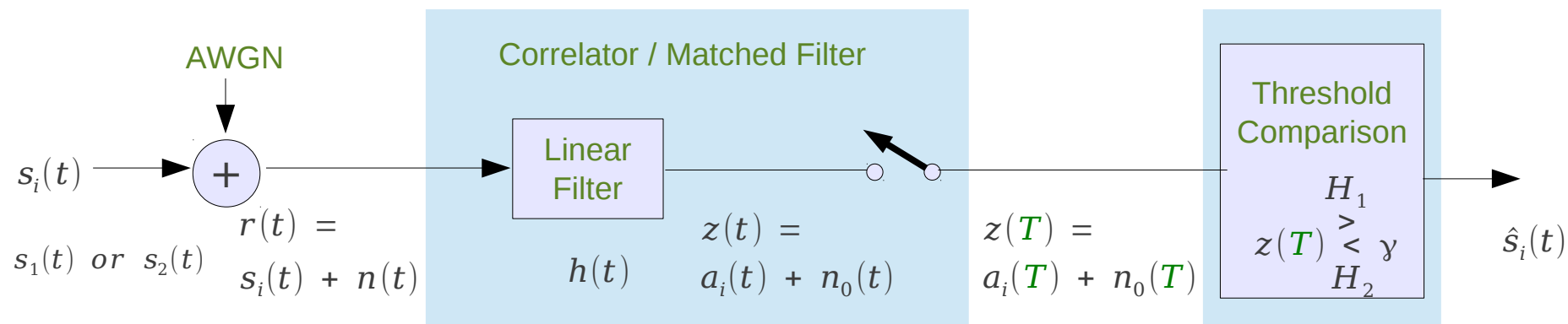

# Binary Correlator Receiver

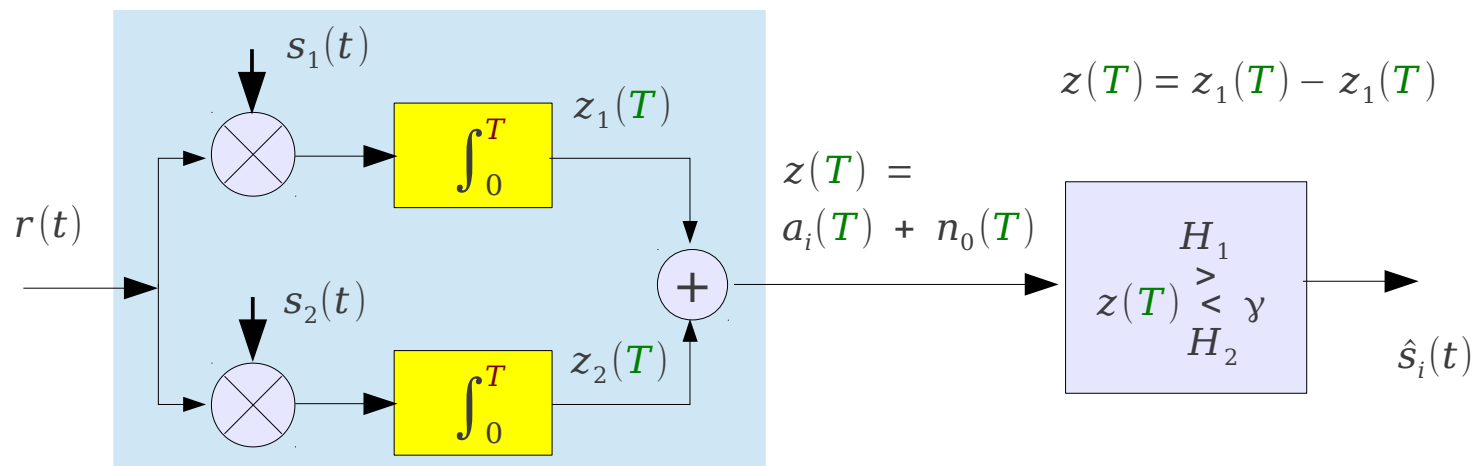

2 correlators



1 correlator

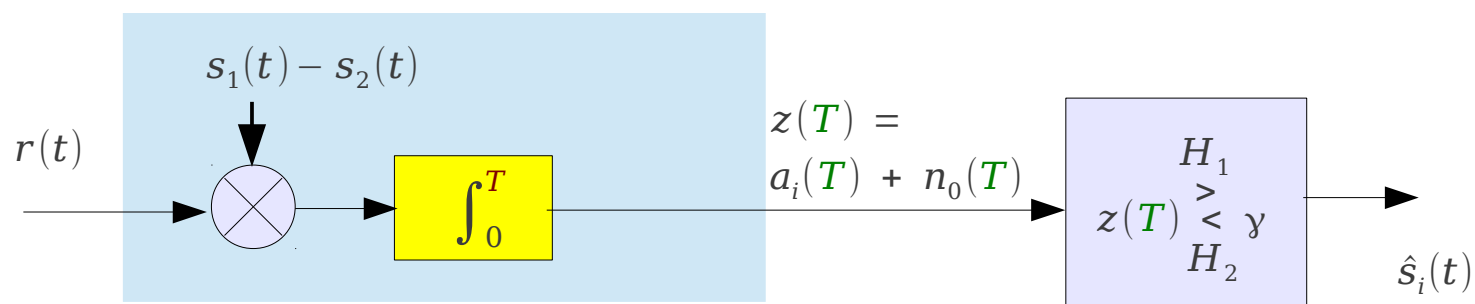

# Energy Difference $E_b$

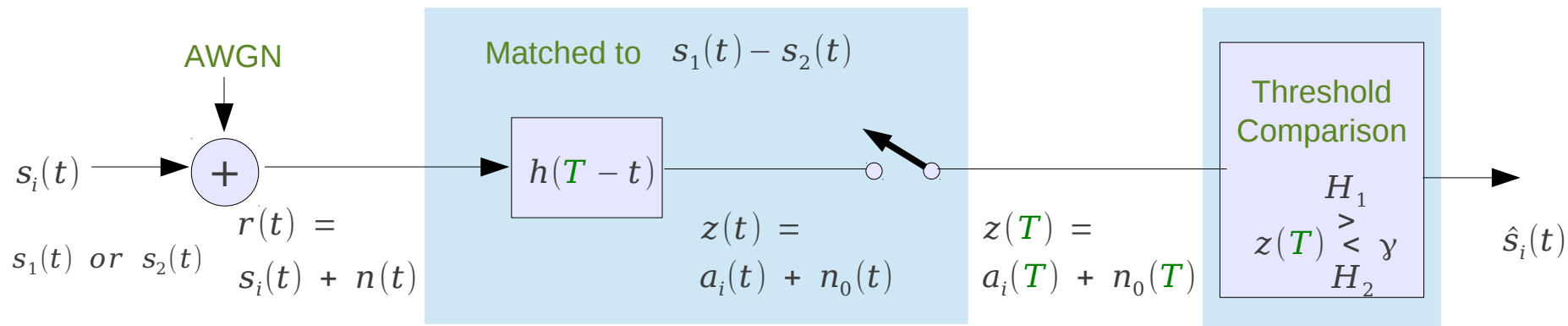

## 1 correlator

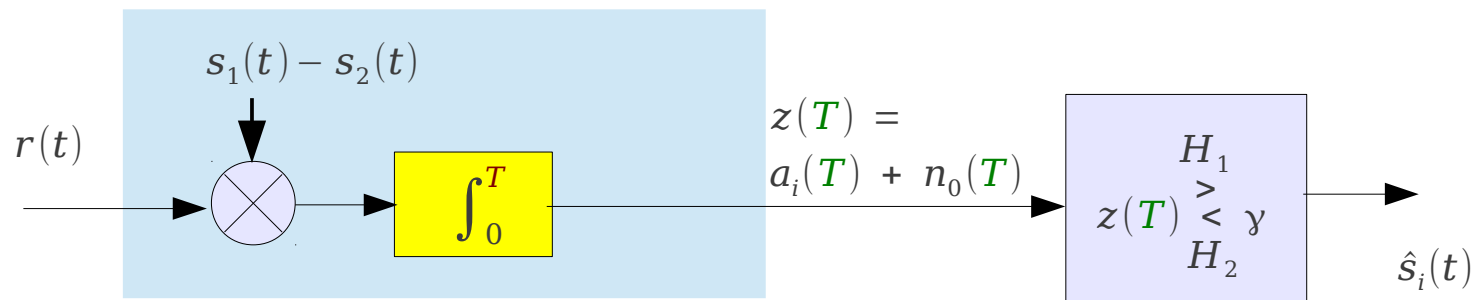

matched to  $s_1 - s_2$

$$\left(\frac{S}{N}\right)_T = \frac{a_1 - a_2^2}{\sigma_0^2} = \frac{2E_d}{N_0}$$

$$\frac{1}{2} \frac{a_1 - a_2}{\sigma_0} = \sqrt{\frac{2E_d}{N_0} \frac{1}{4}}$$

Energy Difference

$$E_d = \int_0^T [s_1(t) - s_2(t)]^2 dt$$

Bit-Error Probability

$$P_B = Q\left(\frac{E_d}{2N_0}\right)$$

# Time Averaging and Ergodicity

---

## References

- [1] <http://en.wikipedia.org/>
- [2] <http://planetmath.org/>
- [3] B. Sklar, “Digital Communications: Fundamentals and Applications”