

# Solar International: SSV design concept

---

## Introduction

The main objective of this EE4 project is to design and build a small solar car which runs on solar power only and which is able to race against other SSV's. The car will be evaluated on speed, originality, and innovation. The main goal in this design will be speed, but we will try to achieve this speed through design concepts which also are original and innovative. The main focus will be designing a car which is as light as possible (exactly the 750g minimum) while also trying to get the least amount of friction. If we combine this with an optimized gear ratio, we hope to achieve our goal of getting a fast car and possibly even win the race.

## Design Concept

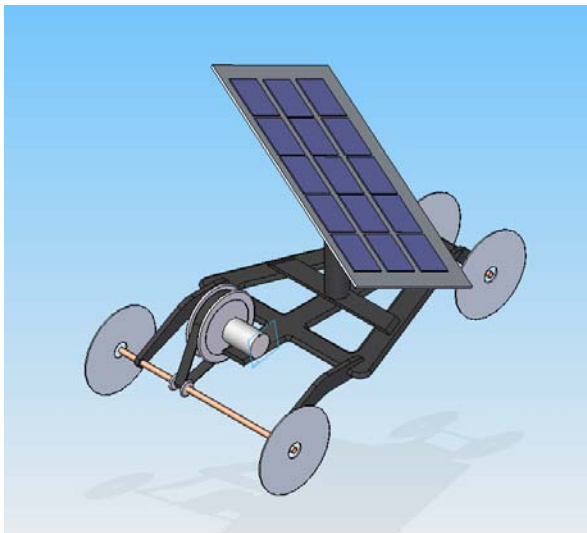

Picture 1 Solar car

## Chassis

In the chassis design we've set two goals, first of all the chassis has to be sturdy enough to cope with the weight of the solar panel and the rest of the car. A second goal is to achieve this sturdiness with a design which is also very light.

This is why we have opted for a triangular chassis, on which 4 wheels will be mounted. A triangular chassis will give enough stability for a light car and weighs less than a rectangular chassis.

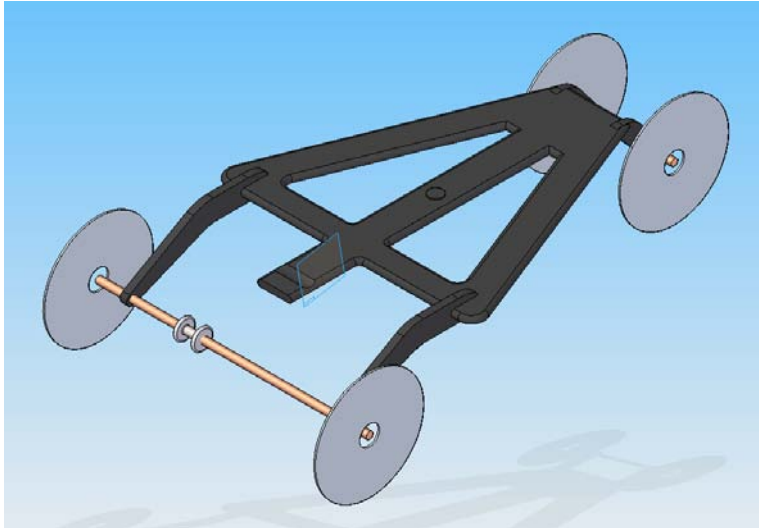

Picture 2 Chassis

The broadest side of the chassis will be the back side. On the back side two wheels will be mounted, along with the electric motor and transmission which will drive the rear wheels.

The front side of the chassis will also be used to mount to wheels, but these wheels will be much closer together and will not be driven.

The solar panel will be mounted somewhere in the middle of the chassis and will be positioned in a way that there is equal weight distribution on all four wheels.

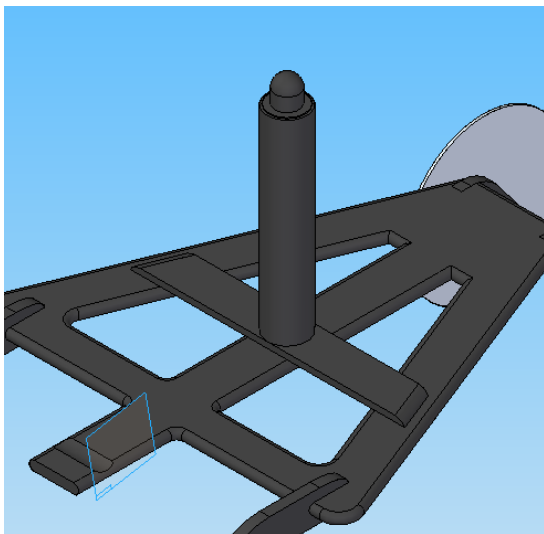

Picture 3 Mounting beam

In the middle of the chassis will be a support beam on which the solar panel will be mounted. The mounting of the panel will be discussed later on.

The material we will use is a polymer called polyoxymethylene, also known as Delrin. This material was chosen because it is both rigid and light. Another advantage of Delrin is that it's very suited for lasercutting. This makes it possible to make a very accurate chassis design with the appropriate software and use a laser cutter to get the exact shape we want.

## Wheel holders and wheels

Four wheel holders will be used to attach the wheels to the chassis. These wheel holders will have slots which match slots that are made in the chassis. This way the wheel holders can easily be slid into place and then be glued to the chassis. The slots will also be laser cut so we can position the wheels exactly where we want them. The holders will also be made out of Delrin.

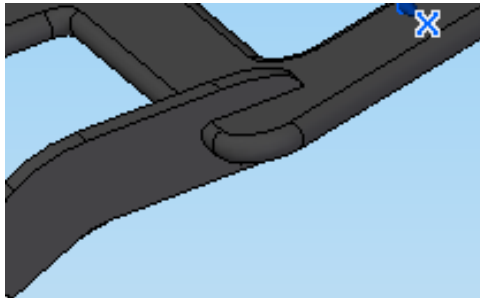

Picture 4 Slots

The wheels will be attached to an axle made of steel. We do this because it is important that the wheelbase is strong enough. First, the idea was that the axle would rotate in the holes we made in the Delrin wheel holders because Delrin is known for its low friction coefficient with steel. However, comparing the values with the friction coefficient of bearings we realize that this friction coefficient is lower.

For that reason we will use bearings on the places where the axle fits in the Delrin. This decision is based on the values of the following tables.

Coefficient of friction in bearings	
	Coefficient of friction [-]
Slide bearing, hydrodynamic	0.003...0.04
Slide bearing, sinter bronze, oil lubricated	0.04...0.07
Slide bearings, solid bronze, grease lub	0.07...0.12
Polymer slide bearing, polyamide, dry	0.2...0.3
Polymer bearing, composite, dry	0.05...0.15
<b>Ball bearings</b>	<b>0.001...0.0015</b>
<b>Roller bearings</b>	<b>0.0018</b>
Needle bearings	0.0045
Air bearings, pressurized	0.0
Hydrostatic bearings	0.001...0.002, ref viscous s

Table 2 Coefficient of friction in bearings

Coefficient of Friction*		
	Static	Dynamic
<b>Delrin on Steel</b>		
Delrin 100, 500, 900	0.20	0.35
Delrin 500CL	0.10	0.20
Delrin AF	0.08	0.14
Delrin on Delrin		
Delrin 500/Delrin 500	0.30	0.40
Delrin on Zytel		
Delrin 500/Zytel 101	0.10	0.20

\*Thrust Washer test, nonlubricated, 23°C (73°F); P, 2.1 MPa (300 psi); V, 3 m/min (10 ft/min).

Table 1 Coefficient of friction with Delrin

The wheels themselves will be minidisks. We use minidisks because they are very narrow, light and easy to find. The narrowness will help us achieve the least amount of rolling friction.

## Solar Panel

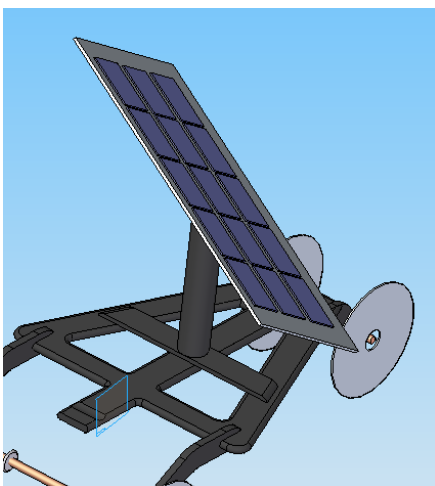

Picture 5 Solar Panel

The solar panel will be mounted on a vertical beam. This vertical beam will be mounted on the central beam of the chassis. An extra support beam perpendicular to the chassis central beam will help divide the weight.

The solar panel will be mounted on the vertical beam using a ball joint. This will be a lockable ball joint, with this we can easily adjust the angle of the panel and lock it in place when the right angle is found. The wiring of the panel will run along the vertical beam to the electric motor.

## Motor & Transmission

To mount the motor on the chassis we've extended the perpendicular beam on the chassis, it looks like an extra protrusion tailing at the back of the chassis. The motor will be resting on this extension in such a way the axis of rotation is laid parallel with the axis of the back wheels. This way we can easily apply a simple belt transmission with the appropriate gear ratio between the motor and the wheel axis.

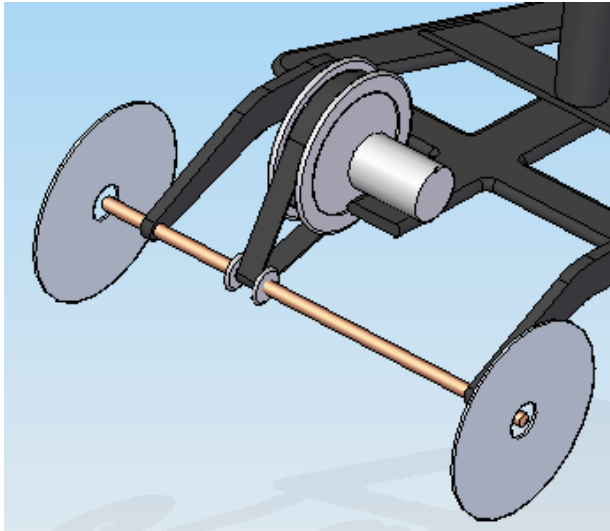

Picture 6 Transmission

The gear ratio will probably be 7:1, resulting out of our Simulink Calculations. We won't manufacture the gear out of the Delrin polymer, but we will most likely order them from a specialized business. For the belt we will likely disassemble a VCR-player and reuse the belt we find in there.