

MPI Programming Techniques

-
-

Copyright (c) 2012 Young W. Lim.

Permission is granted to copy, distribute and/or modify this document under the terms of the GNU Free Documentation License, Version 1.2 or any later version published by the Free Software Foundation; with no Invariant Sections, no Front-Cover Texts, and no Back-Cover Texts. A copy of the license is included in the section entitled "GNU Free Documentation License".

Please send corrections (or suggestions) to youngwlim@hotmail.com.

This document was produced by using OpenOffice and Octave.

Eager Protocol

For **short** messages

The message itself + supplementary information (**message envelope**)
may be sent and stored at the receiver side
without receiver's intervention

A **matching receiver** operation may **not be needed**
But afterward, the message in the **intermediate buffer**
must be copied to the **receive buffer**

- + **Synchronization** overhead is reduced
- May require large amount of preallocated **buffer space**
- **Flooding** a process with many eager messages may overflow → **contention**

Rendezvous Protocol

For **large** messages

Buffering the data is impossible

The **message envelope** is **immediately stored** at the receiver

The actual message transfer **blocks** until the user's **receive buffer** is available

Extra **data copy** could be avoided,
improving **effective bandwidth**,
but sender and receiver must **synchronize**.

Blocking Communication

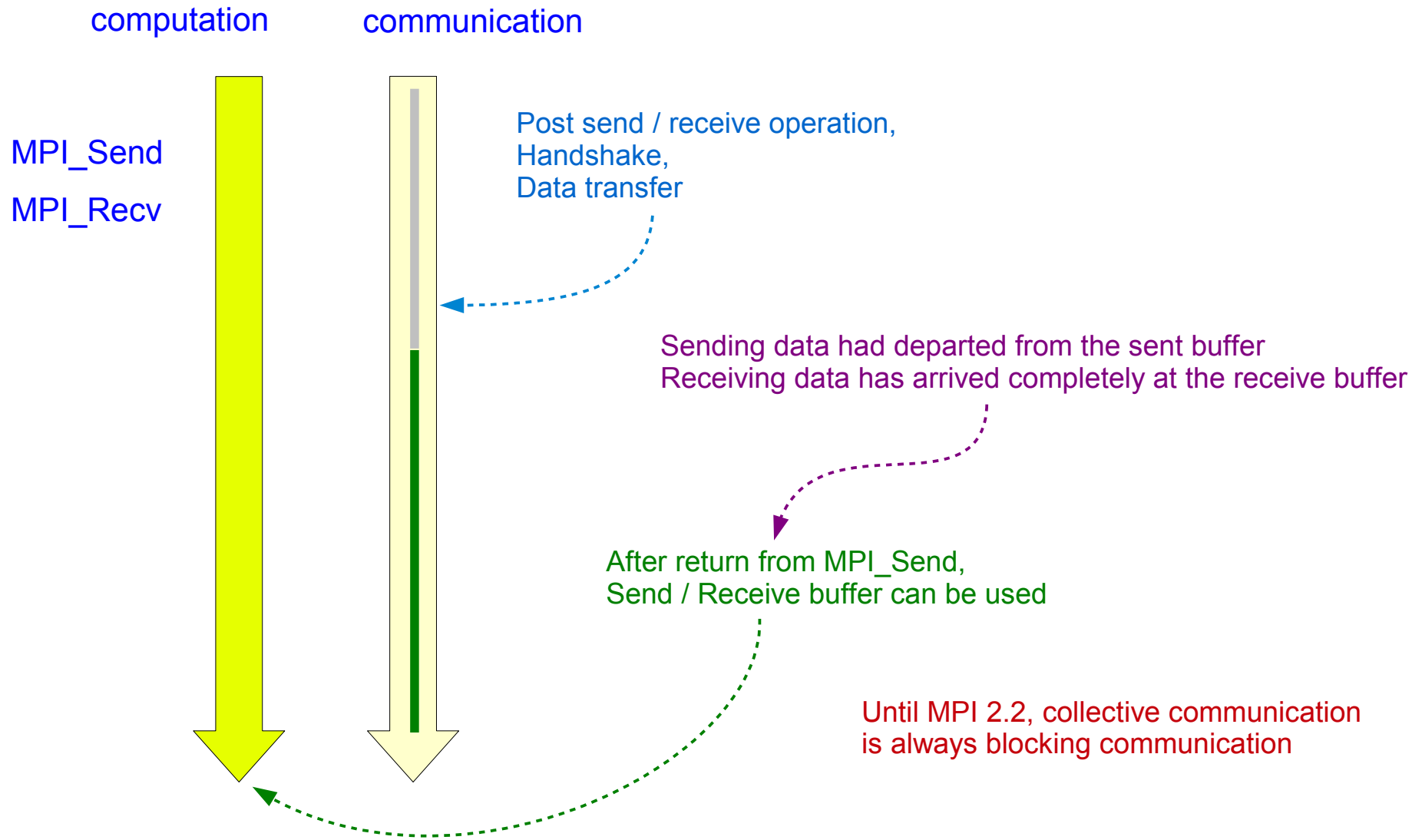

Non-Blocking Communication (1)

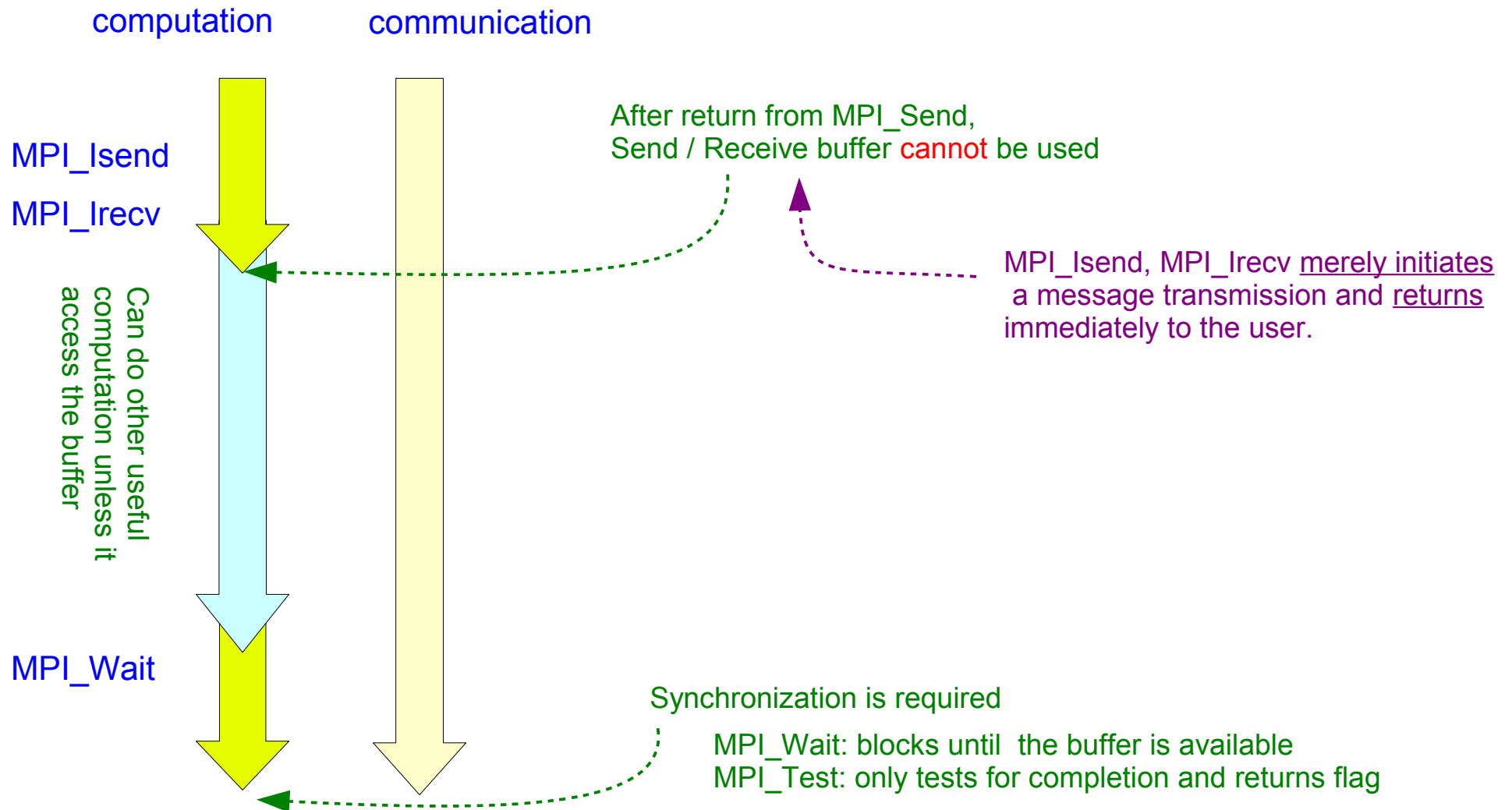

Non-Blocking Communication (2)

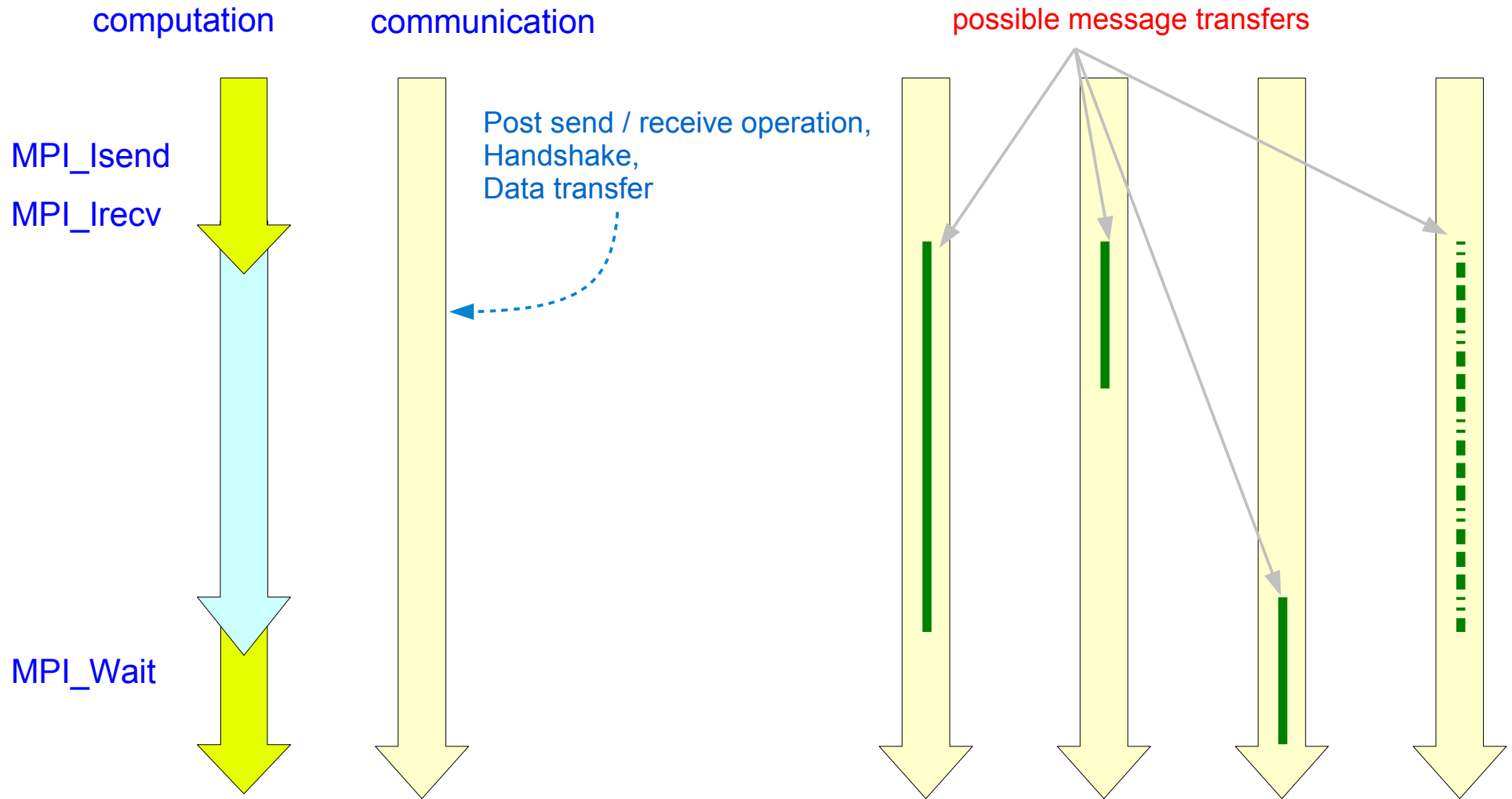

Multiple Request

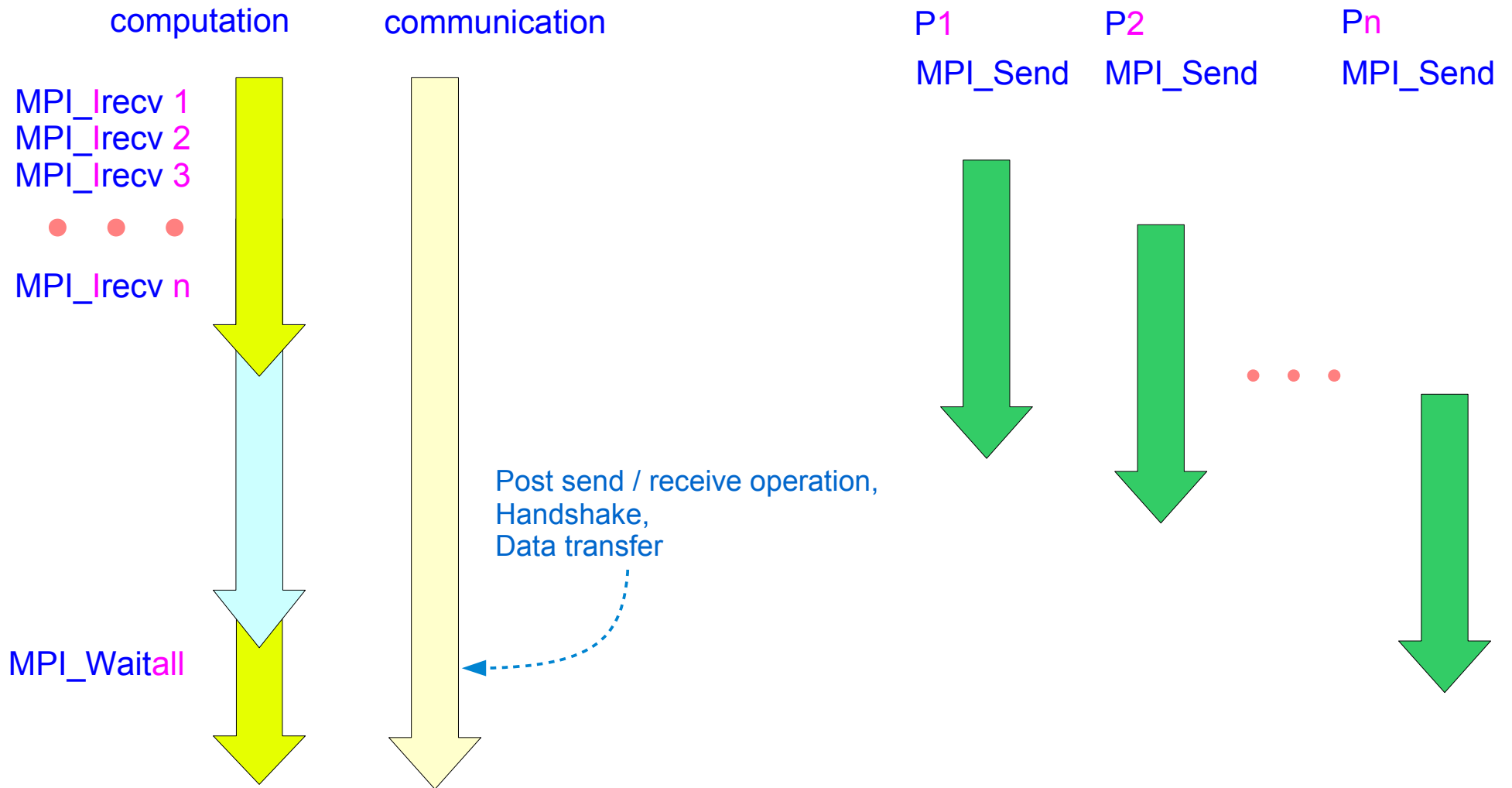

Implicit Serialization and Synchronization

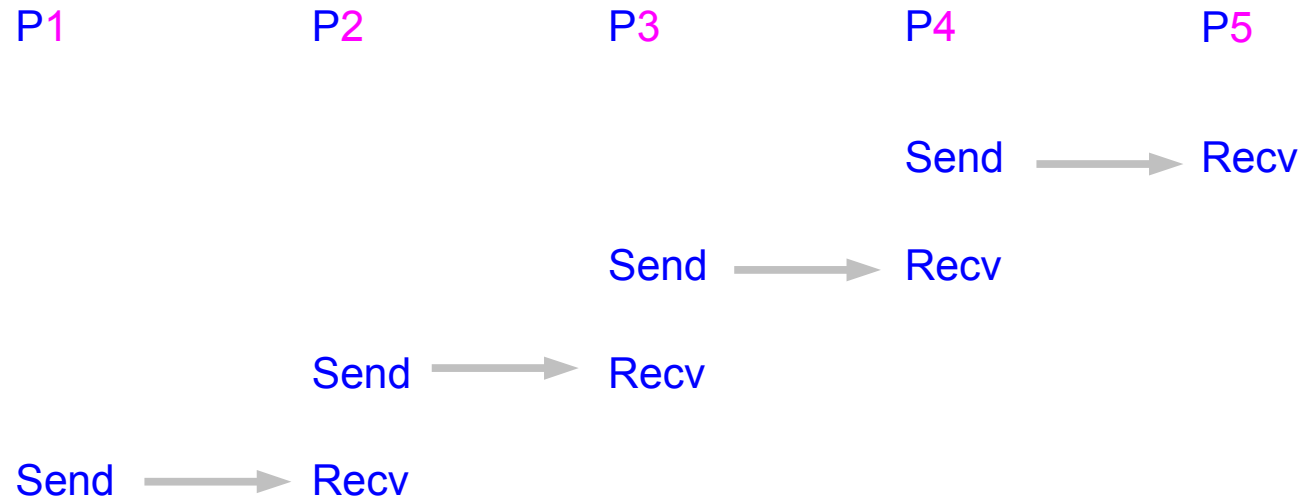

Implicit Serialization and Synchronization

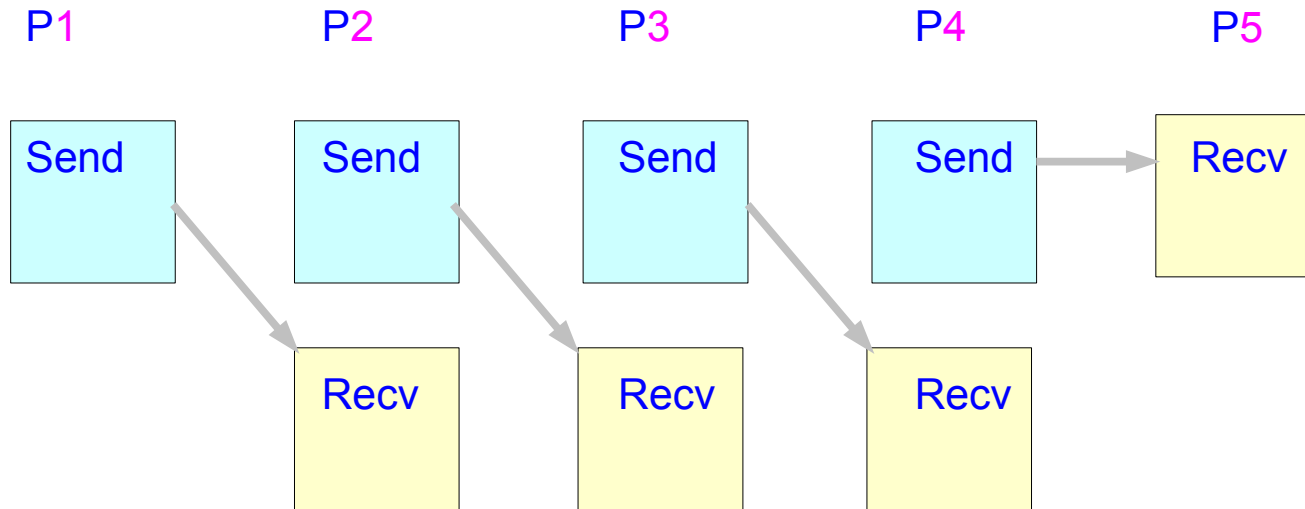

Blocking but not Synchronous Send

Blocking Recv

Eager Delivery

Not Synchronous – enables a send to end before the corresponding recv is posted

Implicit Serialization and Synchronization

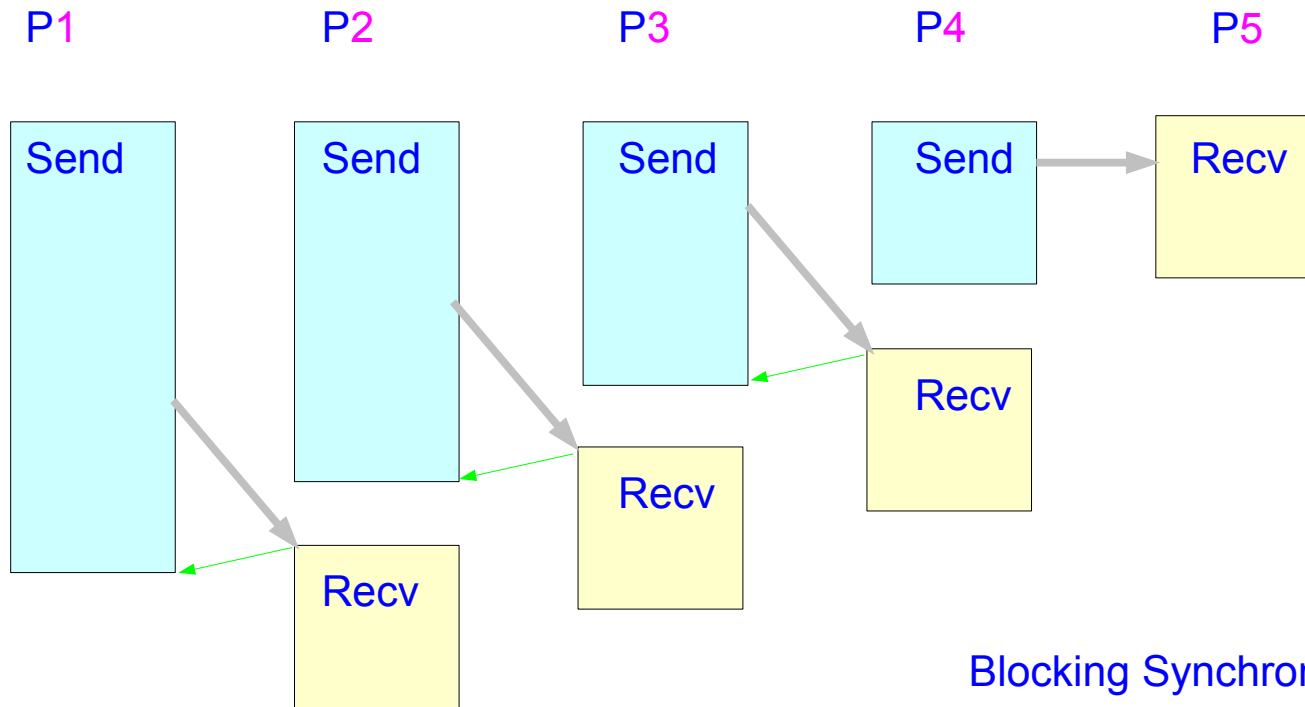

Blocking Synchronous Send

Blocking Recv

Eager Delivery

Synchronous – forces a send finish only after it's matching recv is posted

Implicit Serialization and Synchronization

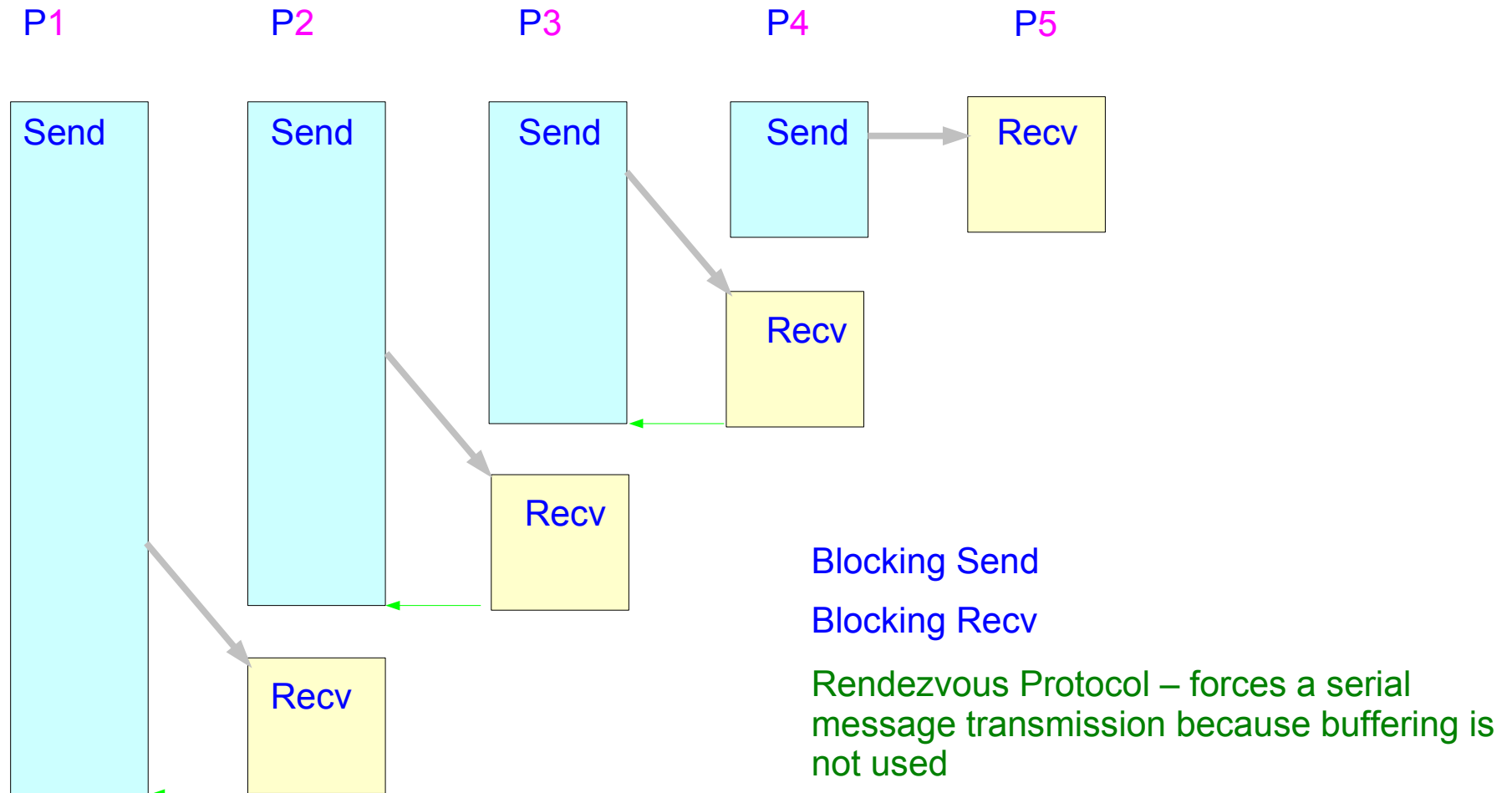

Rank Reorder

PE 0, 1, 2, 3, 4, 5, 6,

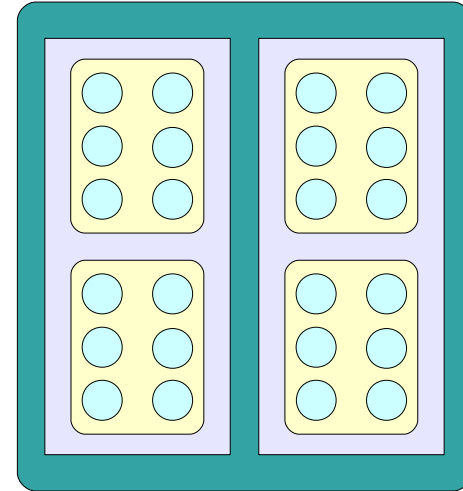
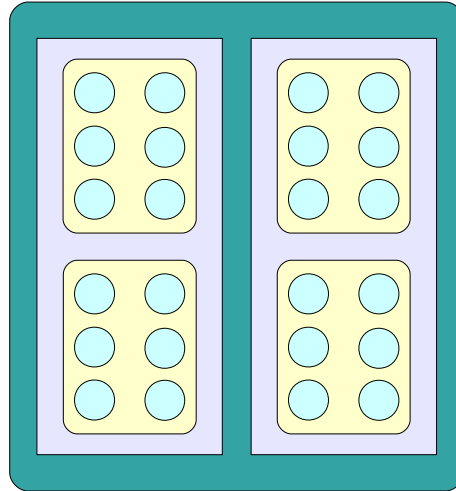
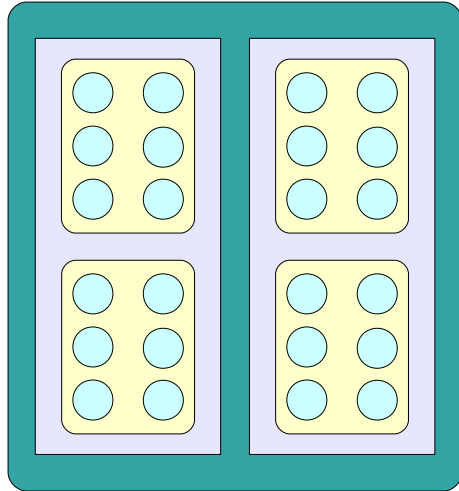

Ex) MPICH on CrayPAT

ROUND-ROBIN

SMP-STYLE

FOLDED RANK

MPICH_RANK_REORDER_METHOD

One rank per node, wrap around

Sequential ranks are placed on the next node

Fill up one node before going to next

All cores from all nodes are allocated in a sequential order

One rank per node, wrap back

Rank

- MPI_Comm_size** : Determines the size of the group associated with a communicator
- MPI_Comm_rank** : Determines the rank of the calling process in the communicator
- MPI_Cart_create** : Makes a new communicator to which **topology information** has been attached
- MPI_Dims_create** : Creates a division of processors in a cartesian grid
- MPI_Cart_coords** : Determines **process coords** in cartesian topology given rank in group
- MPI_Cart_rank** : Determines **process rank** in communicator given Cartesian location
- MPI_Cart_shift** : Returns the **shifted source and destination ranks**, given a shift
Direction and amount

Rank

int **MPI_Comm_size** (MPI_Comm comm, int *size)

int **MPI_Comm_rank** (MPI_Comm comm, int *rank)

int **MPI_Cart_create** (MPI_Comm comm_old, int ndims, int *dims, int *periods,
int reorder, MPI_Comm *comm_cart)

int **MPI_Dims_create** (int nnodes, int ndims, int *dims)

int **MPI_Cart_coords** (MPI_Comm comm, int rank, int maxdims, int *coords)

int **MPI_Cart_rank** (MPI_Comm comm, int *coords, int *rank)

int **MPI_Cart_shift** (MPI_Comm comm, int direction, int displ, int *source, int *dest)

Rank

```
int MPI_Cart_create (MPI_Comm comm_old, int ndims, int *dims, int *periods,  
                    int reorder, MPI_Comm *comm_cart)
```

```
MPI_Cart_create (MPI_COMM_WORLD,                // standard communicator  
                2,                               // two dimensions
```

Nonblocking s. Asynchronous Communication

Nonblocking :

implies that the **message buffer cannot be used** after the call has returned from the MPI library.

It depends on the implementation whether **data transfer (MPI progress)** takes place outside MPI while user code is being executed

```
T = MPI_Wtime()
```

```
MPI_Irecv(...);  
do_work( delay );  
MPI_Wait(...);
```

```
T = MPI_Wtime() - T;
```

If MPI_Irecv() triggers a **truly asynchronous** data transfer,

the measured overall time will stay constant with increasing delay until the delay equals the message transfer time. Beyond this point, there will be a linear rise in execution time.

If MPI progress occurs **only inside the MPI library** (which means, in this example, within MPI_Wait()),

the time for data transfer and the time for executing do_work() will always add up and there will be linear rise of overall execution time starting from zero delay

Nonblocking s. Asynchronous Communication

If `MPI_Irecv()` triggers a **truly asynchronous** data transfer, the measured overall time will stay constant with increasing delay until the delay equals the message transfer time. Beyond this point, there will be a linear rise in execution time.

If MPI progress occurs **only inside the MPI library** (which means, in this example, within `MPI_Wait()`),

the time for data transfer and the time for executing `do_work()` will always add up and there will be linear rise of overall execution time starting from zero delay

```
T = MPI_Wtime()
```

```
MPI_Irecv(...);  
do_work( delay );  
MPI_Wait(...);
```

```
T = MPI_Wtime() - T;
```

only inside the MPI library

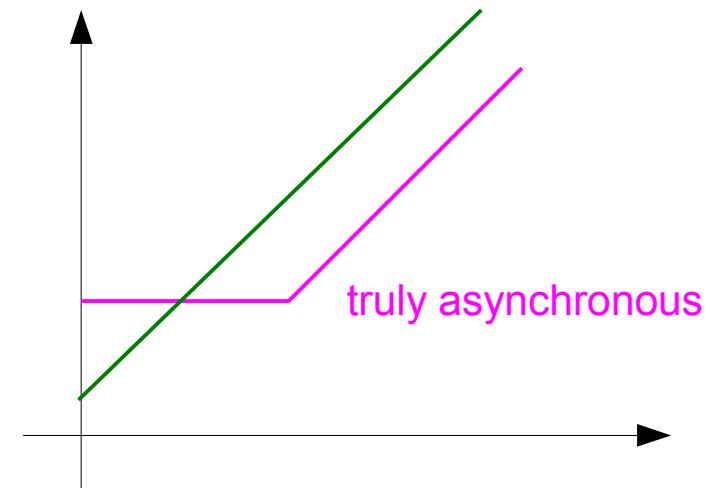

Intranode point-to-point communication (1)

Cray XT5 system

One XT5 node

– 2 AMD Opteron chips

 With a 2MB quad-core L3 group each

These nodes are connected via 3D torus network

Different Level of
point-to-point communication characteristics

Intranode intrasocket : inside an L3 group

Intranode intersocket : between core on different sockets

Internode : between different nodes

Internode ↔ Intranode : large difference

Intersocket ↔ Intrasocket : similar

Intranode point-to-point communication (2)

False Assumption:

Any intranode MPI communication is infinitely fast.

Depends on the MPI implementation

When the MPI library is not aware of intranode communication, relatively slow network protocols are used instead of memory-to-memory copies

Nontemporal stores or cache line zero

Depending on message size and cache sizes

Large message / No shared cache : avoid the write allocate

Single copy (simple block copy command)

From send buf to recv buf

(synchronizing rendezvous protocol)

Intermediate buffer (additional copy)

Hardware support for intranode memory-to-memory copy

Ping-Pong Benchmark (1)

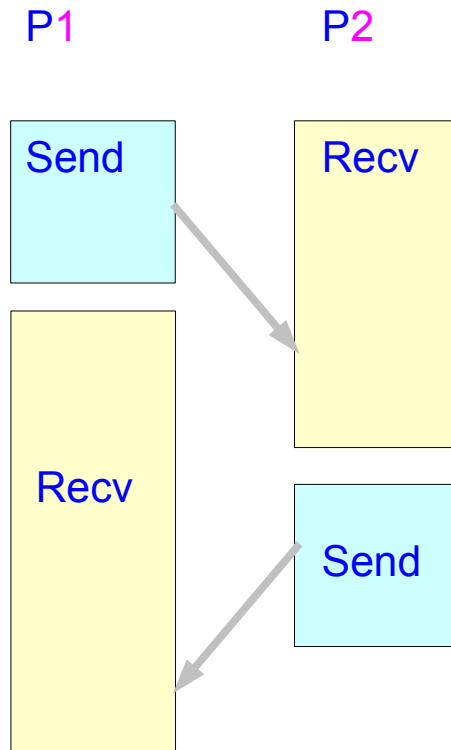

$$T = T_l + \frac{N}{B}$$

Message Size

Latency

Max Bandwidth

$$B_{eff} = \frac{N}{T} = \frac{N}{T_l + N/B}$$

A multicore processor with a shared cache
- fit into the cache

IMB (Intel Benchmarks)

Ping-Pong Benchmark (2)

$$T = T_l + \frac{N}{B}$$

Small sized message : latency dominating

$$T \approx T_l$$

$$B_{eff} = \frac{N}{T} = \frac{N}{T_l + N/B}$$

Large sized message : effective bandwidth saturating

$$B_{eff} \approx B$$

Measured latency with $N=0$

May be inaccurate because of the followings:

All protocols have some overhead (headers)

Some protocols have min message size > 1 byte

Involves multiple software layers (added latencies)

May not have optimized low-latency I/O

Different buffering algorithms at a certain message size

Extremely large message must be split into smaller chunks

Ping-Pong Benchmark (3)

$$T = T_l + \frac{N}{B}$$

$$B_{eff} = \frac{N}{T} = \frac{N}{T_l + N/B} = \frac{B}{2} \quad T_l = \frac{N_{1/2}}{B} \quad BT_l = N_{1/2}$$

$$B_{eff}(B, T_l) = \frac{N}{T_l + N/B}$$

$$B_{eff}(\beta B, T_l) = \frac{N}{T_l + N/\beta B}$$

$$\frac{B_{eff}(\beta B, T_l)}{B_{eff}(B, T_l)} = \frac{T_l + N/B}{T_l + N/\beta B} = \frac{1 + N/BT_l}{1 + N/\beta BT_l} = \frac{1 + N/N_{1/2}}{1 + N/\beta N_{1/2}}$$

Whether an increase in maximum network bandwidth by a factor of β is really beneficial for all messages?

Message Aggregation

References

- [1] <http://en.wikipedia.org/>
- [2] http://static.msi.umn.edu/tutorial/scicomp/general/MPI/mpi_coll_new.html
- [3] <https://computing.llnl.gov/tutorials/mpi/>
- [4] <https://computing.llnl.gov/tutorials/mpi/>
- [5] Hager & Wellein, Introduction to High Performance Computing for Scientists and Engineers
- [6] <http://www.mpi-forum.org/docs/mpi-11-html>